



Stepping System Accessories

AMT Series Stepping System Encoders

CUI Devices' AMT series encoders are award-winning technologically advanced capacitive encoders with a variety of uses. Small, configurable, robust, and inexpensive, AMT encoders have won Product of the Year from Electronic's Weekly and from Electronic Products magazines.

AMT series encoders are typically mounted to the back of a stepper motor, but they can be used in many other applications. Instead of manufacturing many different encoders with different resolutions, CUI Devices offers the AMT series encoders with configurable pulses per revolution (PPR). The PPR can be set for most models using the free AMT Viewpoint software (available at <https://www.automationdirect.com/support/software-downloads?itemcode=AMT%20ViewPoint>). The AMT10 family of encoders are configured using DIP switches.

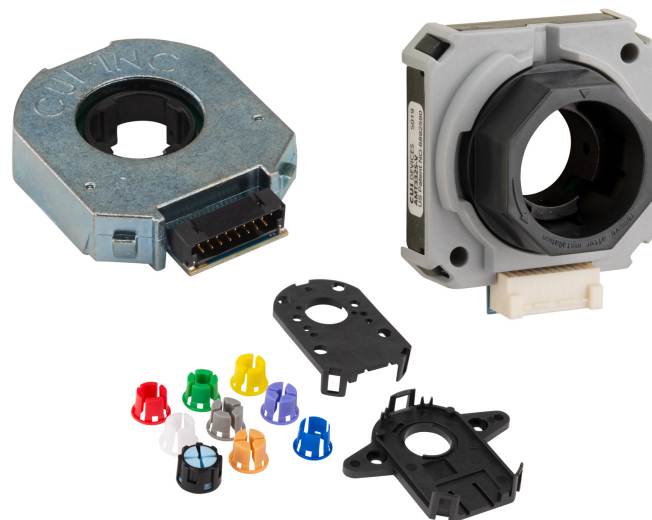

CUI Devices AMT Series Encoders

Encoder Model Overview

AMT series encoders include six distinct model lines (families) designed to meet specific needs.

- AMT10 – DIP switch configurable incremental quadrature encoders. Good for NEMA 14, NEMA 17, and NEMA 23/24 size motors.
- AMT11 – SW configurable resolution incremental quadrature encoders. Good for NEMA 14, NEMA 17, and NEMA 23/24 size motors (motor shaft sizes 2mm, 3mm, 1/8", 4mm, 3/16", 5mm, 6mm, 1/4", 8mm).
- AMT13 – Similar to AMT11, but these are larger sized and good for NEMA 34 and NEMA 42 motors (motor shaft sizes 9mm, 3/8", 10mm, 11mm, 12mm, 1/2", 13mm, 14mm, 5/8").
- AMT31 – A modified version of AMT11 with additional Hall-effect sensor outputs for commutation. This is needed for motors that don't have Hall-effect sensors mounted inside the motor. Typically "commutation encoders" are used with brushless DC (BLDC) motors and drives. Good for NEMA 14, NEMA 17, and NEMA 23/24 size motors.
- AMT33 – Same encoder + commutation features as the AMT31 family, but larger size for use with NEMA 34 and NEMA 42 motors.

Capacitive Encoders

A capacitive encoder is comprised of three main components: a rotor, a stationary transmitter, and a stationary receiver. The rotor contains a sinusoidal pattern and, as it rotates, the high frequency reference signal of the transmitter is modulated in a predictable way. The encoder detects the changes in capacitance-reactance on the receiver board and translates them, using a demodulation algorithm, into increments of rotary motion.

Advantages of Capacitive Encoders

Derived from the same principles used in digital calipers, capacitive encoders have an excellent track record. The AMT series has proven to be both highly reliable and accurate. A capacitive encoder is more rugged than an optical encoder, tolerating a range of environmental contaminants such as dust, dirt, and oil. Capacitive encoders also hold-up much better to vibration and temperature extremes. Further, with no LED, it has a longer lifetime, a smaller footprint, and lower current consumption (6 to 18 mA) than an optical encoder. Immune to magnetic interference and electrical noise, it is as rugged as a magnetic encoder, but delivers greater accuracy and higher resolution.

Given their digital nature, capacitive encoders also offer increased flexibility, allowing users to change the encoder's resolution while a typical optical or magnetic encoder must be swapped out each time a different resolution is needed.

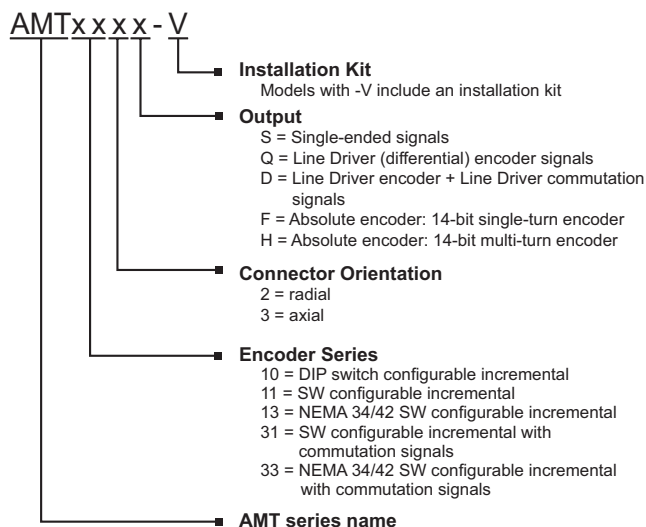

The programmable resolutions available in capacitive encoders are not only useful for system optimization, particularly when designing the PID control loop, but can reduce inventory holding, as one model can be used across multiple applications. Capacitive technology also allows the ability to digitally set the index pulse and alignment of the encoder for BLDC commutation, while its built-in diagnostic capabilities provide designers access to valuable system data for quick troubleshooting in the field.



Stepping System Accessories

AMT Series Stepping System Encoders

Replacement Encoders

The [AMT112Q-V](#) is a replacement for the encoder that comes pre-mounted on the STP-MTR(x)-xxxxE step motors. Step motor part numbers that end in "E" have encoders pre-mounted on the rear shaft. Models that end in "D" are the same motors, without the pre-mounted encoders. If you would like a different encoder then should purchase the "D" model motor and the encoder separately.

Installation tools and mounting hardware are included with all CUI Devices brand AMT series replacement encoders. For more information and details on how to wire the replacement encoders, please see the SureStep User Manual.

PPR

CUI Devices defines PPR, pulses per revolution, as the number of high pulses per channel per revolution. CPR, the number of counts that a controller could determine from a quadrature encoder (both channels have a rising and a falling edge), is 4 x PPR.

For more information regarding PPR, CPR, or LPR (Lines Per Revolution) view <https://www.cuidevices.com/blog/what-is-encoder-ppr-cpr-and-lpr>.

Optional Encoders

Optional encoders can be purchased separately for standard integrated motor/drives and standalone dual-shaft motors in all NEMA 14, 17, 23, 34, and 42 motors. All "D" model (dual-shaft) step motors come with pre-drilled holes in the rear end cap for easy modular encoder mounting. Pre-installed encoders on standalone dual-shaft motors and standard integrated motor/drives can be retrofitted with an appropriate optional encoder if desired. Please see the chart on the following page for encoder compatibility.



AMT102-V



AMT103-V

AMT Series Encoders			
Part Number	listprice	Description	Drawing
AMT102-V	\$25.00	CUI Devices incremental (quadrature) modular encoder, 5 VDC, radial, push-pull (totem) output, DIP switch configurable up to 2048 ppr. For use with NEMA 14, 17, and 23 dual shaft motors.	PDF
AMT103-V	\$25.00	CUI Devices incremental (quadrature) modular encoder, 5 VDC, axial, push-pull (totem) output, DIP switch configurable up to 2048 ppr. For use with NEMA 14, 17, and 23 dual shaft motors.	PDF
AMT112S-V	\$34.50	CUI Devices incremental (quadrature) modular encoder, 5 VDC, radial, push-pull (totem) output, configurable up to 4096 ppr. For use with NEMA 14, 17, and 23 dual shaft motors.	PDF
AMT112Q-V	\$39.50	CUI Devices incremental (quadrature) modular encoder, 5 VDC, radial, line driver (differential) output, configurable up to 4096 ppr. For use with NEMA 14, 17, and 23 dual shaft motors.	PDF
AMT312D-V	\$46.50	CUI Devices incremental (quadrature)/commutation modular encoder, 5 VDC, radial, line driver (differential) encoder output, configurable up to 4096 ppr, line driver (differential) commutation output. For use with NEMA 14, 17, and 23 dual shaft motors.	PDF
AMT312S-V	\$38.50	CUI Devices incremental (quadrature)/commutation modular encoder, 5 VDC, radial, push-pull (totem) encoder output, configurable up to 4096 ppr, push-pull (totem) commutation output. For use with NEMA 14, 17, and 23 dual shaft motors.	PDF



AMT112S-V



AMT312D-V

See Accessories section for configuration and signal cables. CUI Devices Datasheets provide detailed encoder specifications. These datasheets can be found on each encoder's web page at www.automationdirect.com.



Stepping System Accessories

AMT Series Stepping System Encoders

AMT Series Encoders, continued			
Part Number	Price	Description	Drawing
AMT132S-V	\$34.50	CUI Devices incremental (quadrature) modular encoder, 5 VDC, radial, push-pull (totem) output, configurable up to 4096 ppr. For use with NEMA 34 and 42 dual shaft motors.	PDF
AMT132Q-V	\$38.50	CUI Devices incremental (quadrature) modular encoder, 5 VDC, radial, line driver (differential) output, configurable up to 4096 ppr. For use with NEMA 34 and 42 dual shaft motors.	PDF
AMT332S-V	\$38.50	CUI Devices incremental (quadrature)/commutation modular encoder, 5 VDC, radial, push-pull (totem) encoder output, configurable up to 4096 ppr, push-pull (totem) commutation output. For use with NEMA 34 and 42 dual shaft motors.	PDF
AMT332D-V	\$42.50	CUI Devices incremental (quadrature)/commutation modular encoder, 5 VDC, radial, line driver (differential) encoder output, configurable up to 4096 ppr, line driver (differential) commutation output. For use with NEMA 34 and 42 dual shaft motors.	PDF

See Accessories section for configuration and signal cables.
 CUI Devices Datasheets provide detailed encoder specifications. These datasheets can be found on each encoder's web page at www.automationdirect.com.



AMT132S-V

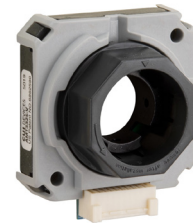

AMT332S-V

AMT Series Encoder Accessories		
Part Number	Price	Description
CUI-KIT-1	\$6.50	CUI Devices encoder accessory kit, replacement. For use with CUI Devices AMT102 encoders. Includes (1) AMT102 base, (1) AMT102 wide base, and (1) AMT10 sleeve kit (9 sleeves sized from 2-8mm).
CUI-KIT-2	\$6.50	CUI Devices encoder accessory kit, replacement. For use with CUI Devices AMT103 encoders. Includes (1) AMT standard base, (1) AMT standard wide base, and (1) AMT10 sleeve kit (9 sleeves sized from 2-8mm).
CUI-KIT-3	\$6.50	CUI Devices encoder accessory kit, replacement. For use with CUI Devices AMT11, AMT21, and AMT31 encoders. Includes (1) AMT standard base, (1) AMT standard wide base, and (1) AMT standard sleeve kit (9 sleeves sized from 2-8mm).
CUI-KIT-4	\$6.50	CUI Devices encoder sleeve kit, replacement. For use with CUI Devices AMT13 and AMT33 encoders. Includes (8) sleeves sized from 9-14mm.
STP-MTRA-SCRWKT-1	\$5.50	SureStep encoder mounting screw kit, for use with all stepper encoders.



CUI-KIT-1



CUI-KIT-2



CUI-KIT-3



CUI-KIT-4



STP-MTRA-SCRWKT-1



Stepping System Accessories

AMT Series Stepping System Encoders

AMT Series Encoder Compatibility							
Part Number	Max PPR	Bore Diameter	Output Type	PLC Compatibility	Encoder Cable	Configuration Cable	Motor Compatibility
AMT102-V	2048	2mm, 3mm, 1/8", 4mm, 3/16", 5mm, 6mm, 1/4", 8mm	push-pull (totem) (radial connector)	BRX ¹ , CLICK C0-1xDxE-D2	CUI-3131-x CUI-3132-1FT	n/a	NEMA 14, 17, 23 dual-shaft
AMT103-V²	2048		push-pull (totem) (axial connector)		CUI-435-x CUI-3934-6FT		
AMT112S-V	4096		push-pull (totem)		AMT-17C-1-x		
AMT112Q-V	4096		line driver (differential)	P2-HSI, P3-HSI, BRX ¹ , CLICK C0-1xDxE-D2	AMT-17C-1-x	AMT-PGRM-17C	
AMT312D-V	4096		line driver (differential) encoder+commutation	P2-HSI, P3-HSI, BRX ¹ , CLICK C0-1xDxE-D2	AMT-17C-1-x	AMT-PGRM-17C	
AMT312S-V	4096		push-pull (totem) encoder+commutation	BRX ¹ , CLICK C0-1xDxE-D2	AMT-17C-1-x		
AMT132S-V	4096		push-pull (totem)		AMT-18C-3-x		
AMT132Q-V	4096	9mm, 3/8", 10mm, 11mm, 12mm, 1/2", 13mm, 14mm, 5/8"	line driver (differential)	P2-HSI, P3-HSI, BRX ¹ , CLICK C0-1xDxE-D2	AMT-18C-3-x	AMT-PGRM-18C	NEMA 34 and 42 ³ dual-shaft (Does not fit STP-MTRAC-34 motors)
AMT332S-V	4096		push-pull (totem) encoder+commutation	BRX ¹ , CLICK C0-1xDxE-D2	AMT-18C-3-x		
AMT332D-V	4096		line driver (differential) encoder+commutation	P2-HSI, P3-HSI, BRX ¹ , CLICK C0-1xDxE-D2	AMT-18C-3-x		

Note: For specific AutomationDirect PLC and step motor model compatibility, please see Appendix A in the SureStep User Manual.

1 - Requires FC-ISO-C (see wiring diagrams for DIP switch settings).

2 - For AMT103-V to maintain NEMA23 compatibility, CUI-KIT-2 must be purchased to use the standard wide base for mounting.

3 - For STP-MTRAC(H)-42 series motors, encoder mounting kit STP-MTRA-42ENC is required.

AMT Series Encoder Signal Cables			
Part Number	Price	Description	Drawing
CUI-3132-1FT	\$5.00	CUI Devices encoder cable, 5-pin connector to pigtail, 1ft cable length. For use with CUI Devices AMT102 encoders.	PDF
CUI-3131-6FT	\$10.50	CUI Devices encoder cable, 5-pin connector to pigtail, shielded, twisted pair, 6ft cable length. For use with CUI Devices AMT102 encoders.	PDF
CUI-3131-10FT	\$30.00	CUI Devices encoder cable, 5-pin connector to pigtail, shielded, twisted pair, 10ft cable length. For use with CUI Devices AMT102 encoders.	PDF
CUI-3131-20FT	\$49.00	CUI Devices encoder cable, 5-pin connector to pigtail, shielded, twisted pair, 20ft cable length. For use with CUI Devices AMT102 encoders.	PDF
CUI-435-1FT	\$5.50	CUI Devices encoder cable, 5-pin connector to pigtail, 1ft cable length. For use with CUI Devices AMT103 encoders.	PDF
CUI-3934-6FT	\$26.50	CUI Devices encoder cable, 5-pin connector to pigtail, shielded, twisted pair, 6ft cable length. For use with CUI Devices AMT103 encoders.	PDF
CUI-435-10FT	\$22.00	CUI Devices encoder cable, 5-pin connector to pigtail, 10ft cable length. For use with CUI Devices AMT103 encoders.	PDF
CUI-435-20FT	\$30.00	CUI Devices encoder cable, 5-pin connector to pigtail, 20ft cable length. For use with CUI Devices AMT103 encoders.	PDF

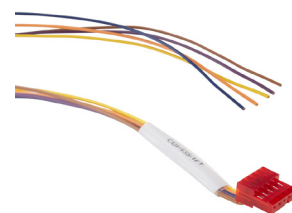

CUI-435-1FT
CUI-435-10FT
CUI-435-20FT



CUI-3131-6FT
CUI-3131-10FT
CUI-3131-20FT

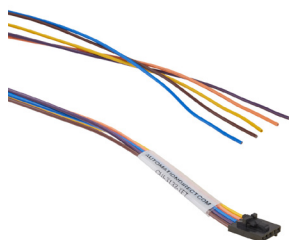

CUI-3132-1FT

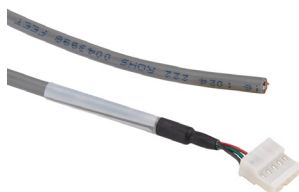

CUI-3934-6FT



Stepping System Accessories

AMT Series Stepping System Encoders

AMT Series Encoder Signal Cables			
Part Number	Price	Description	Drawing
<u>AMT-17C-1-036</u>	\$40.00	CUI Devices encoder cable, 17-pin connector to pigtail, shielded, twisted pair, 3ft cable length. For use with CUI Devices AMT112 and AMT312 encoders.	<u>PDF</u>
<u>AMT-17C-1-072</u>	\$81.00	CUI Devices encoder cable, 17-pin connector to pigtail, shielded, twisted pair, 6ft cable length. For use with CUI Devices AMT112 and AMT312 encoders.	<u>PDF</u>
<u>AMT-17C-1-120</u>	\$121.00	CUI Devices encoder cable, 17-pin connector to pigtail, shielded, twisted pair, 10ft cable length. For use with CUI Devices AMT112 and AMT312 encoders.	<u>PDF</u>
<u>AMT-18C-3-036</u>	\$27.50	CUI Devices encoder cable, 18-pin connector to pigtail, shielded, twisted pair, 3ft cable length. For use with AMT13 and AMT33 encoders.	<u>PDF</u>
<u>AMT-18C-3-072</u>	\$67.00	CUI Devices encoder cable, 18-pin connector to pigtail, shielded, twisted pair, 6ft cable length. For use with AMT13 and AMT33 encoders.	<u>PDF</u>
<u>AMT-18C-3-120</u>	\$96.00	CUI Devices encoder cable, 18-pin connector to pigtail, shielded, twisted pair, 10ft cable length. For use with AMT13 and AMT33 encoders.	<u>PDF</u>

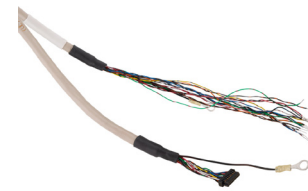

**AMT-17C-1-036
AMT-17C-1-072
AMT-17C-1-120**

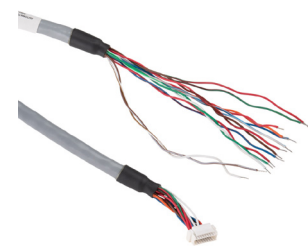

**AMT-18C-3-036
AMT-18C-3-072
AMT-18C-3-120**

AMT Series Encoders Programming Cables		
Part Number	Price	Description
<u>AMT-PGRM-17C</u>	\$27.00	CUI Devices programming cable, miniB-USB to 17-pin connector, 1ft cable length. For use with CUI Devices AMT112 and AMT312 encoders.
<u>AMT-PGRM-18C</u>	\$24.50	CUI Devices programming cable, miniB-USB to 18-pin connector, 1ft cable length. For use with CUI Devices AMT13 and AMT33 encoders.



AMT-PGRM-17C



AMT-PGRM-18C



Stepping System Accessories

AMT Series Stepping System Encoders

Line Driver Encoder Wiring Colors				
Encoder	AMT112Q-V AMT312D-V		AMT132Q-V AMT332D-V	
Pin Function	Pin #	STP-CLB-EBx AMT-17C-1-xxx Wire Color	Pin #	AMT-18C-3-xxx Wire Color
+5V	6	RED/BLK	6	RED/GRN
GND	4	BLK/RED	4	GRN/RED
A	10	WHT/BLK	8	BRN/WHT
\bar{A}	11	BLK/WHT	9	WHT/BRN
B	8	GRN/BLK	10	GRN/WHT
\bar{B}	9	BLK/GRN	11	WHT/GRN
Z	12	BLU/BLK	12	BLU/WHT
\bar{Z}	13	BLK/BLU	13	WHT/BLU

Single Ended (Push-pull/Totem) Encoder Wiring Colors										
Encoder	AMT112S-V AMT312S-V		AMT132S-V AMT332S-V		AMT102-V			AMT103-V		
Pin Function	Pin #	STP-CLB-EBx AMT-17C-1-xxx Wire Color	Pin #	AMT-18C-3-xxx Wire Color	Pin #	CUI-3131-xxx Wire Color	CUI-3132-1FT Wire Color	Pin #	CUI-435-xxx Wire Color	CUI-3934-6FT Wire Color
+5V	6	RED/BLK	6	RED/GRN	5V	RED	ORG	5V	ORG	RED
GND	4	BLK/RED	4	GRN/RED	G	BLACK	BRN	G	BRN	BLACK
A+	10	WHT/BLK	8	BRN/WHT	A	WHT	BLU	A	BLU	WHT
B+	8	GRN/BLK	10	GRN/WHT	B	BRN	YEL	B	YEL	BRN
Z+	12	BLU/BLK	12	BLU/WHT	X	GRN	PUR	X	PUR	GRN

Single Ended (Push-pull/Totem) Commutation Wiring Colors				
Encoder	AMT312S-V		AMT332S-V	
Pin Function	Pin #	AMT-17C-1-xxx Wire Color	Pin #	AMT-18C-3-xxx Wire Color
+5V	6	RED/BLK	6	RED/GRN
GND	4	BLK/RED	4	GRN/RED
U+	3	BRN/BLK	3	BRN/RED
W+	5	ORG/BLK	5	ORG/RED
V+	7	RED/WHT	7	BLU/RED



Stepping System Accessories

AMT Series Encoders – PLC Connectivity

Line Driver Encoder to Line Driver PLC Input

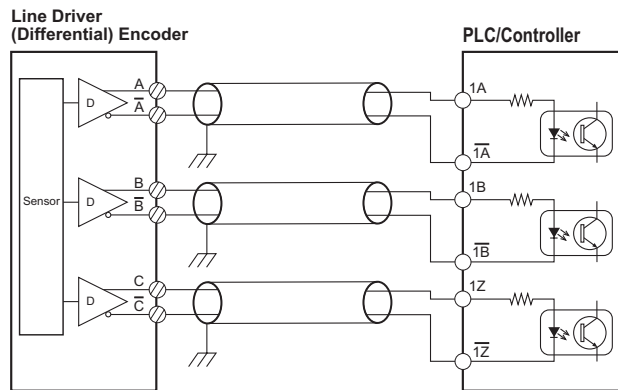

Single Ended (Push-pull/Totem) Encoder to Sourcing PLC

Single Ended (Push-pull/Totem) Encoder to Sinking PLC

