



# GFS/GFSL Series AC Ground Fault Sensors



Ground fault sensors help protect people, products, and processes from damage that can be caused by ground fault conditions. The GFS series monitors all current-carrying conductors in grounded single and three-phase delta or wye systems.

GFS series sensors offer jumper-selectable setpoints of 5, 10 or 30 mA. The GFS models come in a fixed core case with a 0.75" sensing aperture and are UL Recognized. The GFSL models come in a fixed core case with a large 1.87" sensing aperture and are UL Listed.

## Applications

### Personnel Protection (typically 5mA)

- Detects sensitive ground fault conditions, which may be injurious to personnel and processes
- Functions as sensor and alarm trigger when part of an overall ground fault protection system

### Equipment Protection (typically 10mA or 30mA)

For applications where personal protection is not the primary concern, higher setpoint capability helps eliminate nuisance tripping while still providing adequate ground fault detection to protect machine electronics.

### Regulatory

Meets requirements as stipulated by governmental and industrial regulatory groups for ground fault sensing.

## Features

- **Wide Range of Options:** Mechanical relay outputs with Auto or Manual reset.
- **Setpoint Options:** Field selectable 5mA, 10mA or 30mA setpoints makes user adjustments fast, sure and convenient.
- **Compatible with Standard Equipment:** Applicable on single- and three-phase systems. Ideal for use with shunt trip breakers. Magnetically isolated from monitored circuit and control power.
- Built-in feet with optional 35mm DIN rail adapter available. Large aperture version has integral 35mm DIN rail mounting.
- **Not compatible with VFD or SCR Outputs**
- **Five-year warranty**



Click on the thumbnail or go to <https://www.automationdirect.com/VID-CT-0001> for a short introductory video on the AcuAmp Current Switches, Transducers and Indicators



## GFS & GFSL Series Ground Fault Sensors

Part Number	Description	Pcs/Pkg	Wt (lb)	Price
<a href="#"><u>GFS30-M1A-24-F</u></a>	AcuAMP ground fault sensor, fixed core, 5, 10, or 30 mA selectable trip point, relay, SPST-N.O., manual reset output, 24 VAC/VDC operating voltage.	1	0.50	\$283.00
<a href="#"><u>GFS30-M1B-24-F</u></a>	AcuAMP ground fault sensor, fixed core, 5, 10, or 30 mA selectable trip point, relay, SPST-N.C., manual reset output, 24 VAC/VDC operating voltage.	1	0.50	\$283.00
<a href="#"><u>GFS30-D1C-24-F</u></a>	AcuAMP ground fault sensor, fixed core, 5, 10, or 30 mA selectable trip point, relay, SPDT normally de-energized, automatic reset output, 24 VAC/VDC operating voltage.	1	0.50	\$193.00
<a href="#"><u>GFS30-E1C-24-F</u></a>	AcuAMP ground fault sensor, fixed core, 5, 10, or 30 mA selectable trip point, relay, SPDT normally energized, automatic reset output, 24 VAC/VDC operating voltage.	1	0.50	\$205.00
<a href="#"><u>GFS30-M1A-120A-F</u></a>	AcuAMP ground fault sensor, fixed core, 5, 10, or 30 mA selectable trip point, relay, SPST-N.O., manual reset output, 120 VAC operating voltage.	1	0.50	\$283.00
<a href="#"><u>GFS30-M1B-120A-F</u></a>	AcuAMP ground fault sensor, fixed core, 5, 10, or 30 mA selectable trip point, relay, SPST-N.C., manual reset output, 120 VAC operating voltage.	1	0.50	\$283.00
<a href="#"><u>GFS30-D1C-120A-F</u></a>	AcuAMP ground fault sensor, fixed core, 5, 10, or 30 mA selectable trip point, relay, SPDT normally de-energized, automatic reset output, 120 VAC operating voltage.	1	0.50	\$193.00
<a href="#"><u>GFS30-E1C-120A-F</u></a>	AcuAMP ground fault sensor, fixed core, 5, 10, or 30 mA selectable trip point, relay, SPDT normally energized, automatic reset output, 120 VAC operating voltage.	1	0.50	\$205.00
<a href="#"><u>GFSL30-M1A-120A-F</u></a>	AcuAMP ground fault sensor, large aperture fixed core, 5, 10, or 30 mA selectable trip point, relay, SPST-N.O., manual reset output, 120 VAC operating voltage.	1	0.50	\$326.00
<a href="#"><u>GFSL30-M1B-120A-F</u></a>	AcuAMP ground fault sensor, large aperture fixed core, 5, 10, or 30 mA selectable trip point, relay, SPST-N.C., manual reset output, 120 VAC operating voltage.	1	0.50	\$326.00
Accessories				
<a href="#"><u>DRA-2B</u></a>	35mm DIN rail adapters, 1.70"x0.45"x0.83" [43.7x11.4x21.0 mm]	2	0.40	\$6.00



# GFS/GFSL Series AC Ground Fault Sensors

GFS & GFSL Series Specifications		
Models Available	GFS	GFSL
<b>Power Supply</b>	Model 24-F: 24 VAC/DC (20.4-27.6 VAC or 19.2-30 VDC) Model 120A-F: 120VAC (66-132 VAC), 50/60 Hz	120 VAC (66-132 VAC), 50/60 Hz
<b>Monitored Circuit</b>	1500 VAC max, 50-400 Hz	600VAC line-to-line max., 50/60 Hz
<b>Output Signal</b>	SPST or SPDT	SPST (normally open or normally closed)
<b>Output Rating</b>	Manual: SPST Relay, 1A @ 125VAC, 2A @ 30VDC, Auto: SPDT Relay, 1A @ 125VAC, 2A @ 30VDC	Manual Reset: SPST Relay, 1A @ 125VAC, 2A @ 30VDC
<b>Off State Leakage</b>	None	None
<b>Power Consumption</b>	2.5 VA max	2.5 VA max
<b>Setpoint (Trip Point)</b>	5, 10 and 30 mA jumper select	5, 10 and 30 mA jumper select
<b>Response Time</b>	200ms @ 5% above setpoint	200ms @ 5% over setpoint 60ms @ 50% over setpoint 15ms @ 500% over setpoint
<b>Sensing Aperture</b>	0.75" [19.1 mm] diameter	1.82" [46mm] diameter
<b>Isolation Voltage</b>	5kV (tested)	UL tested to 1,048VAC
<b>Case</b>	UL 94V-0 Flammability Rated	UL 94V-0 Flammability Rated
<b>Environmental</b>	Operating temperature: -4 to 122°F (-20 to 50°C)	
	Relative humidity: 0-95% RH, Non-condensing	
	Pollution Degree 2	
	Altitude to 2000 meters	
<b>Certifications</b>	URus recognized 1053 (E343037), CE	cULus listed 508 (E222847), CE

## Wiring

### GFS M1A and M1B Models

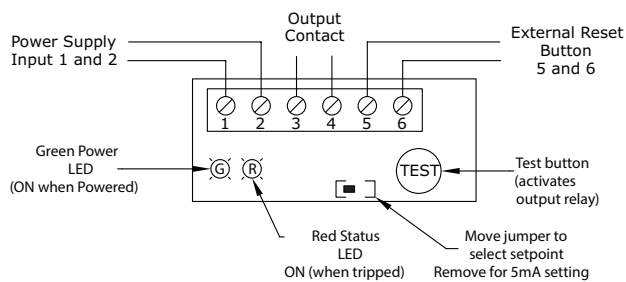

### GFSL M1A and M1B Models

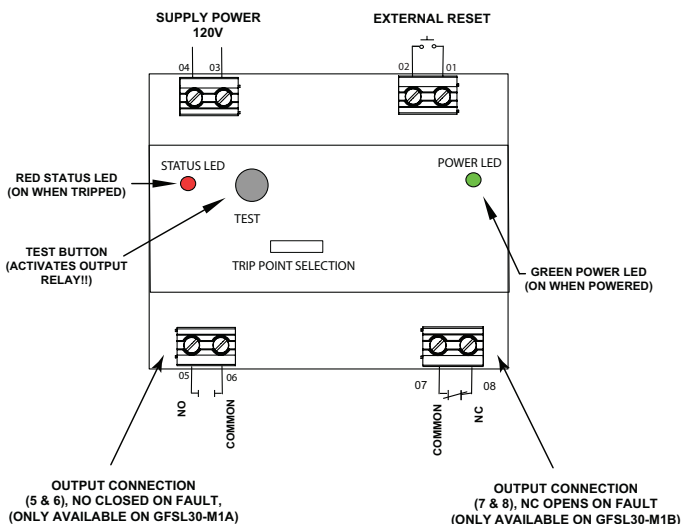

### GFS D1C and E1C Models

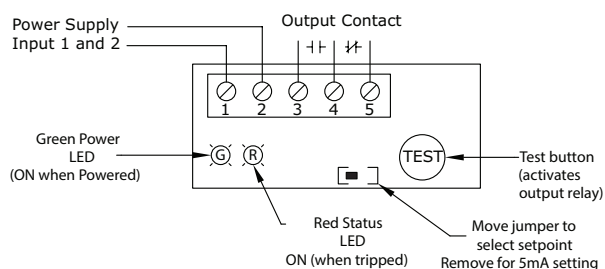

# ACUAMP® GFS/GFSL Series AC Ground Fault Sensors

## Dimensions

Inches [mm]

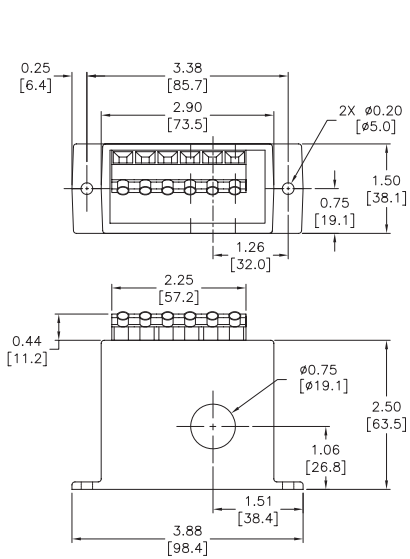

GFS M1A and M1B Models

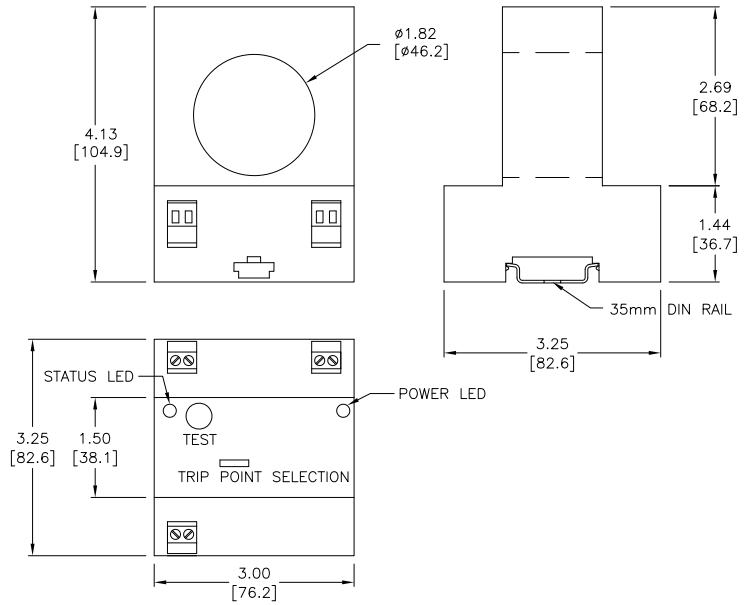

GFSL M1A and MIB Models

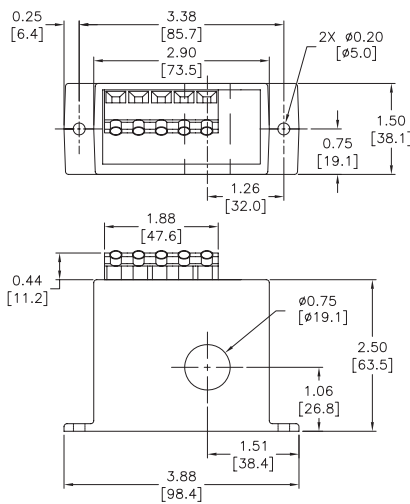

GFS D1C and E1C Models

See our website [www.AutomationDirect.com](http://www.AutomationDirect.com) for complete Engineering drawings.



# Ground Fault Sensors Operation and Applications

## Principle of Operation

### “Zero Sum” Operating Principle:

In three-phase delta and wye systems, under normal conditions current in the ‘hot’ leg of a two-wire load is equal in magnitude but opposite in sign to the

current in the neutral leg. As a result, the electromagnetic fields surrounding these two conductors cancel each other, producing a “zero sum current.” As soon as current leaks to ground

(fault condition), the two currents become imbalanced and a net magnetic field results. GFS Series sensors monitor this field and trip alarm contacts when the leakage rises above setpoint.

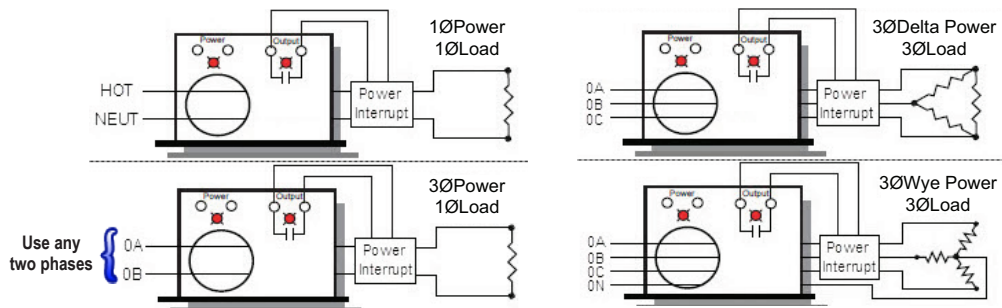

## Operation/Setup

Auto Reset Sensors (E1C and D1C)  
GFS Auto Reset sensors monitor all current carrying conductors and will trip when a ground fault is sensed. The output of these sensors will automatically reset when the ground fault condition is cleared. Select from three factory calibrated setpoints by moving the setpoint jumper to the desired position.

- 5mA setpoint: Detect sensitive ground fault conditions that may be injurious to personnel or processes.
- 10 mA and 30 mA setpoints: These higher setpoints help eliminate nuisance tripping while still providing adequate ground fault protection for machine electronics.

### Normally Energized Models (E1C)

- Used to detect both ground faults and loss of control power

### Normally De-energized Models (D1C)

- Used to detect ground faults

### Manual Reset Sensors

	NO POWER		CONTROL POWER APPLIED			
	Output	LED	No Fault		Fault Detected	
N.C.	Closed	OFF	Open	OFF	Closed	ON
N.O.	Open	OFF	Closed	OFF	Open	ON

### (M1A and M1B)

GFS Manual Reset Sensors monitor all current carrying conductors and will trip when a ground fault is sensed. When the output of these sensors trips it will latch in the tripped position even after

	NO POWER		CONTROL POWER APPLIED			
	Output	LED	No Fault		Fault Detected	
N.C.	Closed	OFF	Closed	OFF	Open	ON
N.O.	Open	OFF	Open	OFF	Closed	ON

the ground fault is cleared. If control power is removed, the sensor remains in its last output state. To reset the sensor, the ground fault condition must be removed and a momentary dry contact closed at the external reset terminals

- Models with M1A suffix: The contact is normally open with no ground fault condition, and closed when a ground fault is sensed.
- Models with M1B suffix: The contact is normally closed with no ground fault condition, and open when a ground fault is sensed.

## Application Examples

### Pump Seal Failure

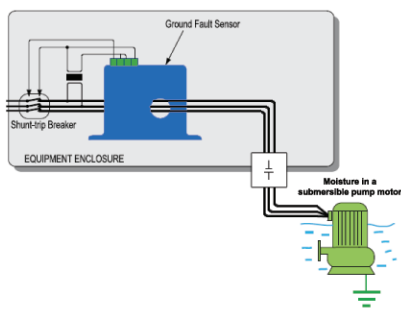

### Insulation Breakdown Monitoring

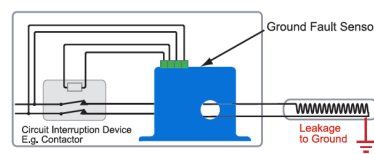

### Snow Melting or Soil Warming System

