

# Frequency Inverter

## CFW320

### User's Manual

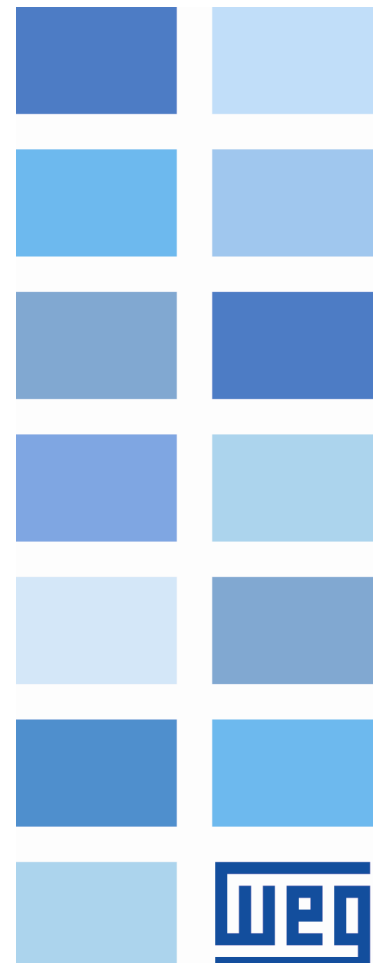





# **User's Manual**

Series: CFW320

Language: English

Document: 10008951923 / 00

Models: Frame Sizes A, B and C

Publication Date: 04/2022

## SUMMARY OF REVISIONS

---

The information below describes the revisions made to this manual.

Version	Revision	Description
-	R00	First Edition.



### **ATTENTION!**

#### **Check the frequency of the power supply.**

In case the power supply frequency is different from the factory setting (check P403), it is necessary to set:

- P204 = 5 for 60 Hz.
- P204 = 6 for 50 Hz.

It is only necessary to set these parameters once.

Refer to the programming manual of the CFW320 for further details about the programming of parameter P204.

<b>1</b>	<b>SAFETY NOTICES</b> .....	<b>1</b>
1.1	SAFETY WARNINGS IN THE MANUAL .....	1
1.2	SAFETY NOTICES ON THE PRODUCT .....	1
1.3	PRELIMINARY RECOMMENDATIONS .....	2
<b>2</b>	<b>GENERAL INFORMATION</b> .....	<b>4</b>
2.1	ABOUT THE MANUAL .....	4
2.2	ABOUT THE CFW320 .....	4
2.3	TERMINOLOGY .....	10
2.4	IDENTIFICATION LABEL .....	11
2.5	RECEIVING AND STORAGE .....	11
<b>3</b>	<b>INSTALLATION AND CONNECTION</b> .....	<b>12</b>
3.1	MECHANICAL INSTALLATION .....	12
3.1.1	Environmental Conditions .....	12
3.1.2	Positioning and Mounting .....	12
3.1.2.1	Cabinet Mounting .....	13
3.1.2.2	Surface Mounting .....	13
3.1.2.3	DIN-Rail Mounting .....	13
3.2	ELECTRICAL INSTALLATION .....	13
3.2.1	Identification of the Power Terminals and Grounding Points .....	13
3.2.2	Circuit Breakers, Fuses, Grounding and Power Cables .....	14
3.2.3	Power Connections .....	15
3.2.3.1	Input Connections .....	17
3.2.3.1.1	Short Circuit Current Ratings (SCCR) .....	17
3.2.3.2	Power Supply Reactance .....	17
3.2.3.3	Dynamic Braking .....	18
3.2.3.4	Output Connections .....	19
3.2.4	Grounding Connections .....	20
3.2.5	Control Connections .....	20
3.2.6	Cable Separation Distance .....	22
3.3	INSTALLATIONS ACCORDING TO EUROPEAN DIRECTIVE OF ELECTROMAGNETIC COMPATIBILITY .....	22
3.3.1	Control Connections .....	22
3.3.2	Emission and Immunity Levels .....	23
3.3.3	Characteristics of the RFI Filter .....	23
<b>4</b>	<b>KEYPAD (HMI) AND BASIC PROGRAMMING</b> .....	<b>25</b>
4.1	USE OF THE KEYPAD TO OPERATE THE INVERTER .....	25
4.2	INDICATIONS ON THE HMI DISPLAY .....	25
4.3	OPERATING MODES OF THE HMI .....	25
<b>5</b>	<b>TROUBLESHOOTING AND MAINTENANCE</b> .....	<b>27</b>
5.1	FAULTS AND ALARMS .....	27
5.2	SOLUTION FOR THE MOST FREQUENT PROBLEMS .....	27
5.3	INFORMATION NECESSARY FOR CONTACTING TECHNICAL SUPPORT .....	28



---

5.4 PREVENTIVE MAINTENANCE .....	28
5.5 CLEANING INSTRUCTIONS .....	29
<b>6 ACCESSORIES.....</b>	<b>30</b>
<b>7 TECHNICAL SPECIFICATIONS .....</b>	<b>31</b>
7.1 POWER DATA .....	31
7.2 ELECTRONICS/GENERAL DATA.....	32
7.2.1 Considered Standards.....	33

# 1 SAFETY NOTICES

This manual provides information for the proper installation and operation of the CFW320 frequency inverter.

It has been written to be used by qualified personnel with suitable training or technical qualification for operating this type of equipment. The personnel must follow all the safety instructions described in this manual and/or defined by the local regulations. Failure to comply with the safety instructions may result in death, serious injury, and equipment damage.

## 1.1 SAFETY WARNINGS IN THE MANUAL

The following safety notices are used in the manual:

**DANGER!**

The procedures recommended in this warning have the purpose of protecting the user against death, serious injuries and considerable material damage.

**DANGER!**

Les procédures concernées par cet avertissement sont destinées à protéger l'utilisateur contre des dangers mortels, des blessures et des détériorations matérielles importantes.

**ATTENTION!**

The procedures recommended in this warning have the purpose of avoiding material damage.

**NOTE!**

The information mentioned in this warning is important for the proper understanding and good operation of the product.

## 1.2 SAFETY NOTICES ON THE PRODUCT

The following symbols are attached to the product, serving as safety notices:



High voltages are present.



Components sensitive to electrostatic discharge. Do not touch them.



Mandatory connection to the protective earth (PE).



Connection of the shield to the ground.

### 1.3 PRELIMINARY RECOMMENDATIONS



**DANGER!**

- Always disconnect the main power supply before touching any electrical component associated to the inverter. Several components can remain charged with high voltages or remain in movement (fans) even after the AC power is disconnected or switched off.
- Wait at least ten minutes after turning off the input power for the complete discharge of the power capacitors.
- Always connect the grounding point of the inverter to the protection earth (PE).



**DANGER!**

- Débranchez toujours l'alimentation principale avant d'entrer en contact avec un appareil électrique associé au variateur. Plusieurs composants peuvent rester chargés à un potentiel électrique élevé et/ou être en mouvement (ventilateurs), même après la déconnexion ou la coupure de l'alimentation en courant alternatif.
- Attendez au moins 10 minutes que les condensateurs se déchargent complètement.
- Toujours connecter le point de mise à la terre du variateur sur la mise à la terre de protection (PE).



**DANGER!**

The XC10 connector is not USB compatible, therefore, it cannot be connected to USB ports. This connector only serves as the interface between the CFW320 frequency inverter and its accessories.



**DANGER!**

La XC10 n'est pas compatible USB, par conséquent, il ne peut pas être connectés à des ports USB. Ce connecteur sert uniquement d'interface entre le CFW320 variateur de fréquence et de ses accessoires.



**NOTE!**

- Frequency inverter may interfere with other electronic equipment. In order to reduce these effects, takes the precautions recommended in the [Chapter 3 INSTALLATION AND CONNECTION](#) on page 12.
- Read the user's manual completely before installing or operating the inverter.

**Do not perform any withstand voltage test (hi-pot test)!  
If necessary, contact WEG.**



**ATTENTION!**

Electronic boards have components sensitive to electrostatic discharges. Do not touch directly on components or connectors. If necessary, first touch the grounding point of the inverter, which must be connected to the protection earth (PE) or use a proper grounding strap.



**DANGER!**

This product was not designed to be used as a safety element. Additional measures must be taken so as to avoid material and personal damages. The product was manufactured under strict quality control, however, if installed in systems where its failure causes risks of material or personal damages, additional external safety devices must ensure a safety condition in case of a product failure, preventing accidents.



**DANGER!**

Ce produit n'est pas conçu pour être utilisé comme un élément de sécurité. Des précautions supplémentaires doivent être prises afin d'éviter des dommages matériels ou corporels.

Ce produit a été fabriqué sous un contrôle de qualité conséquent, mais s'il est installé sur des systèmes où son dysfonctionnement entraîne des risques de dommages matériels ou corporels, alors des dispositifs de sécurité externes supplémentaires doivent assurer des conditions de sécurité en cas de défaillance du produit, afin d'éviter des accidents.

## 2 GENERAL INFORMATION

### 2.1 ABOUT THE MANUAL

This manual contains information for the proper installation and operation of the inverter, commissioning, main technical features and how to identify the most usual problems if the different models of inverters of the CFW320 line.

**ATTENTION!**

The operation of this equipment requires detailed installation and operation instructions provided in the quick installation guide, user's manual, programming manual and communication manuals. The guides are provided in print with their respective accessory, or can be obtained at WEG website - [www.weg.net](http://www.weg.net). A printed copy of the files can be requested at your local WEG dealer.

**NOTE!**

It is not the intention of this manual to present all the possibilities for the application of the CFW320, as well as WEG cannot take any liability for the use of the CFW320 which is not based on this manual.

Part of the figures and tables are available in the annexes, which are divided into [APPENDIX A - FIGURES on page 34](#) for figures and [APPENDIX B - TECHNICAL SPECIFICATIONS on page 45](#) for technical specifications.

For further information, refer to the programming manual.

### 2.2 ABOUT THE CFW320

The CFW320 frequency inverter is a high-performance product which allows speed and torque control of three-phase induction motors. This product provides the user with the options of vector (V/W) or scalar (V/f) control, both programmable according to the application.

In the vector mode (V/W), the operation is optimized for the motor in use, obtaining a better performance in terms of speed regulation.

The scalar mode (V/f) is recommended for simpler applications, such as the activation of most pumps and fans. In such cases it is possible to reduce the losses in the motor and the inverter using the "V/f Quadratic", which results in energy savings. The V/f mode is used when more than a motor is activated by an inverter simultaneously (multimotor applications).

The frequency inverter CFW320 also has functions of PLC (Programmable Logic Controller) by means of the SoftPLC (integrated) feature.

The main components of the CFW320 can be viewed in the blocks diagrams of [Figure 2.1 on page 5](#), for frame size A 220 V, [Figure 2.2 on page 6](#) for frame size A 110V, [Figure 2.3 on page 7](#) for frame size B 220V, [Figure 2.4 on page 8](#) for frame size A 380-480V and [Figure 2.5 on page 9](#) for frame sizes B and C 380-480V.

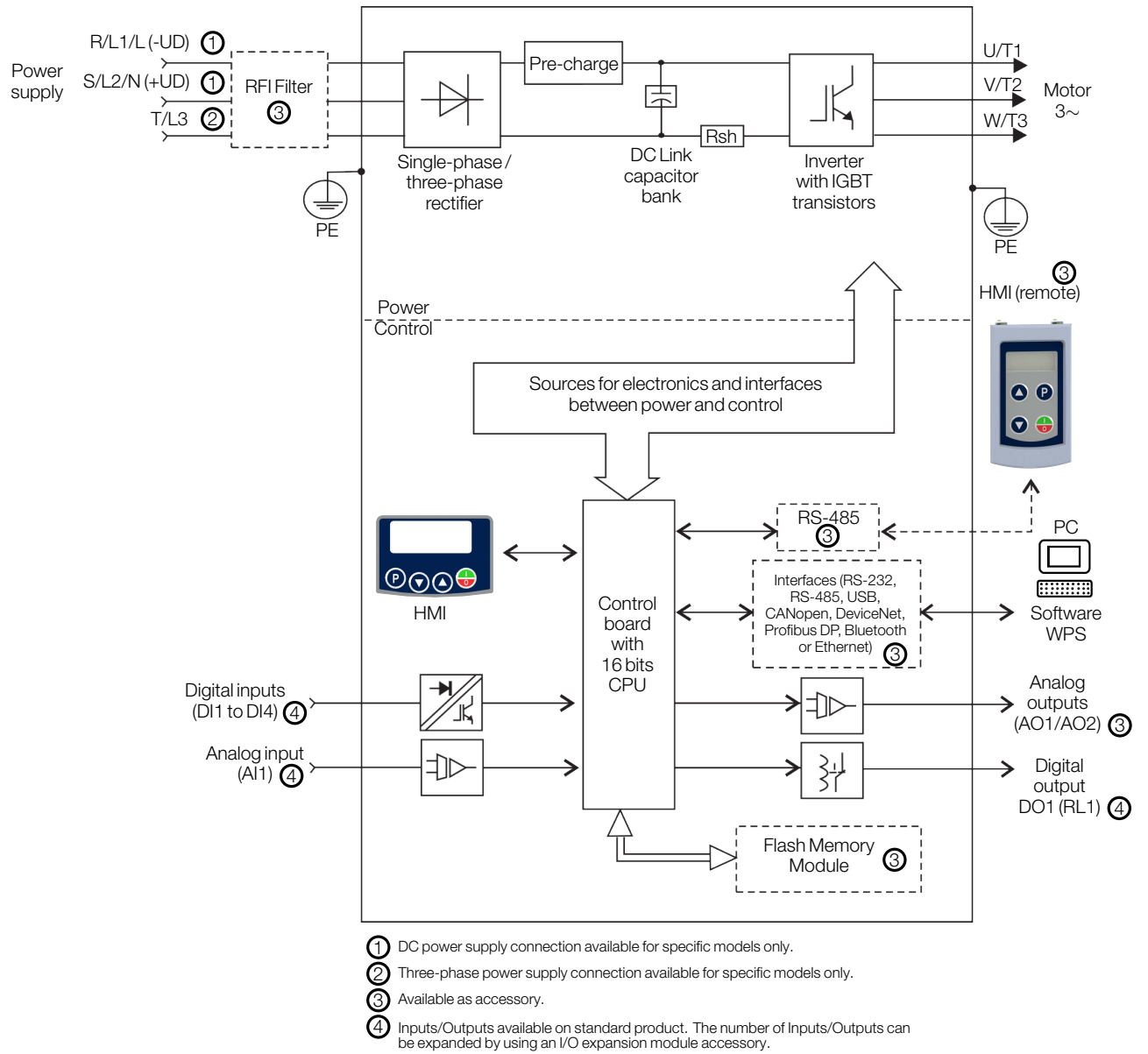
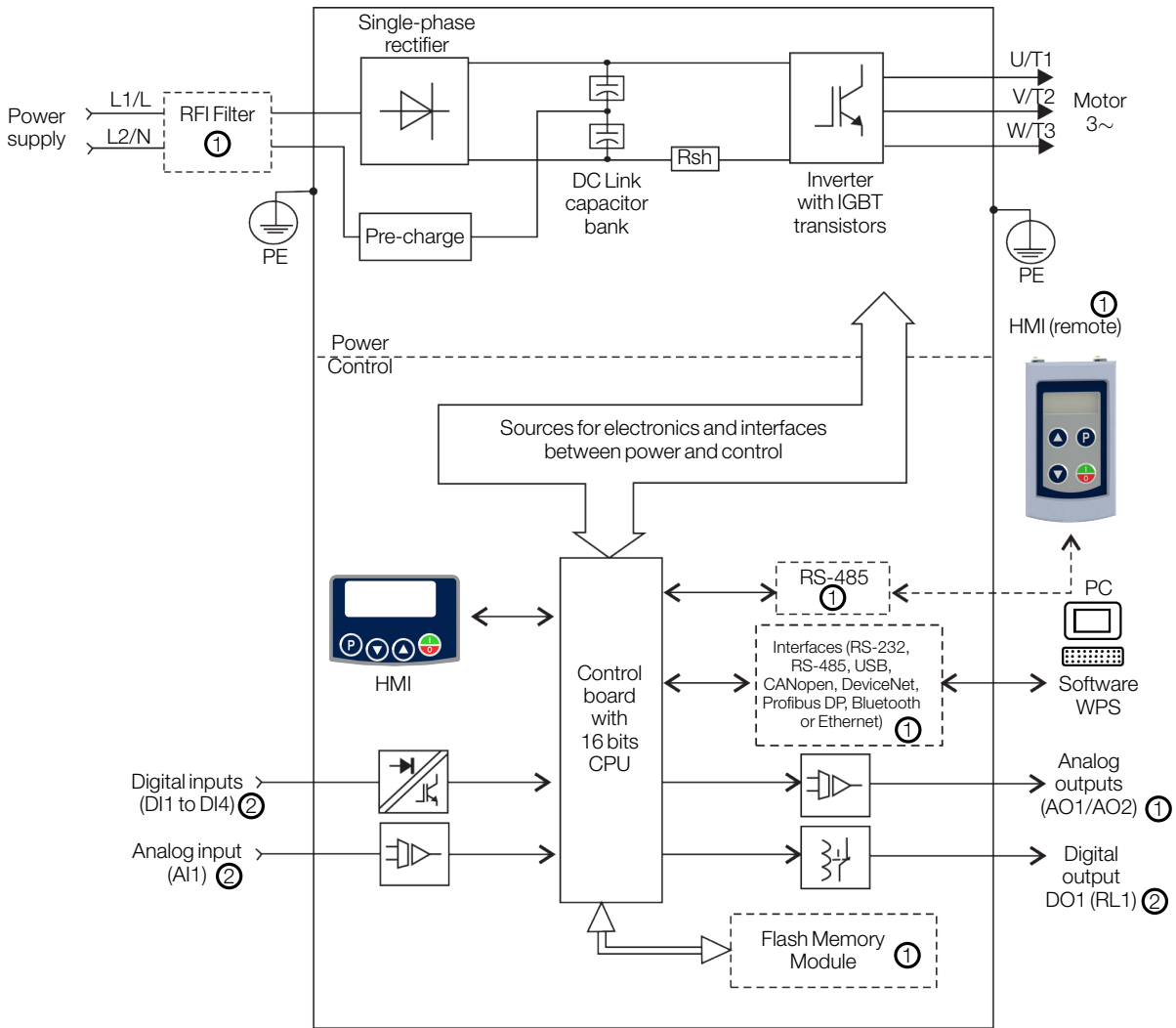

Figure 2.1: Block diagram of CFW320 for frame size A 220V



① Available as accessory.

② Inputs/Outputs available on standard product. The number of Inputs/Outputs can be expanded by using an I/O expansion module accessory.

Figure 2.2: Block diagram of CFW320 for frame size A 110V

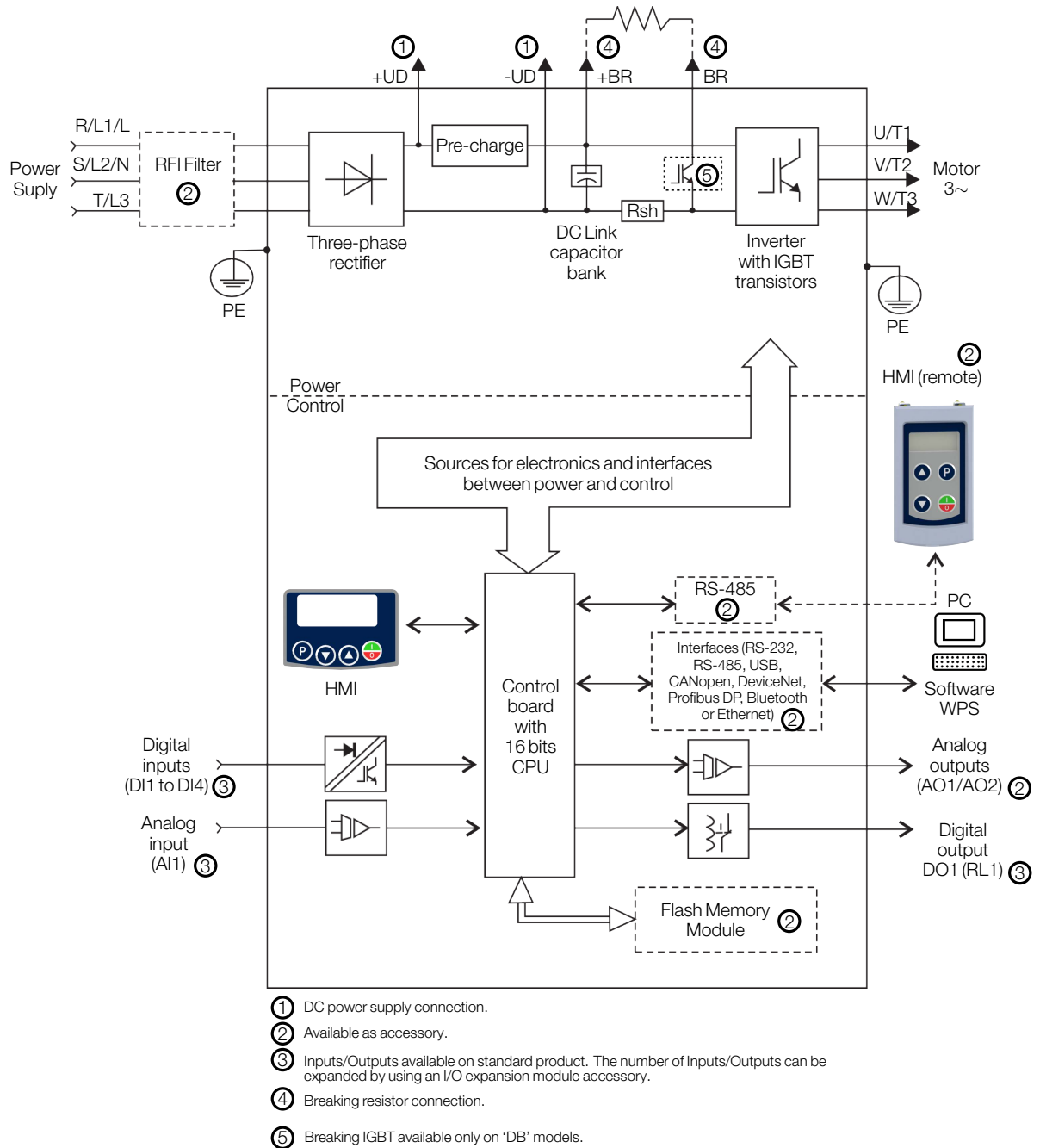
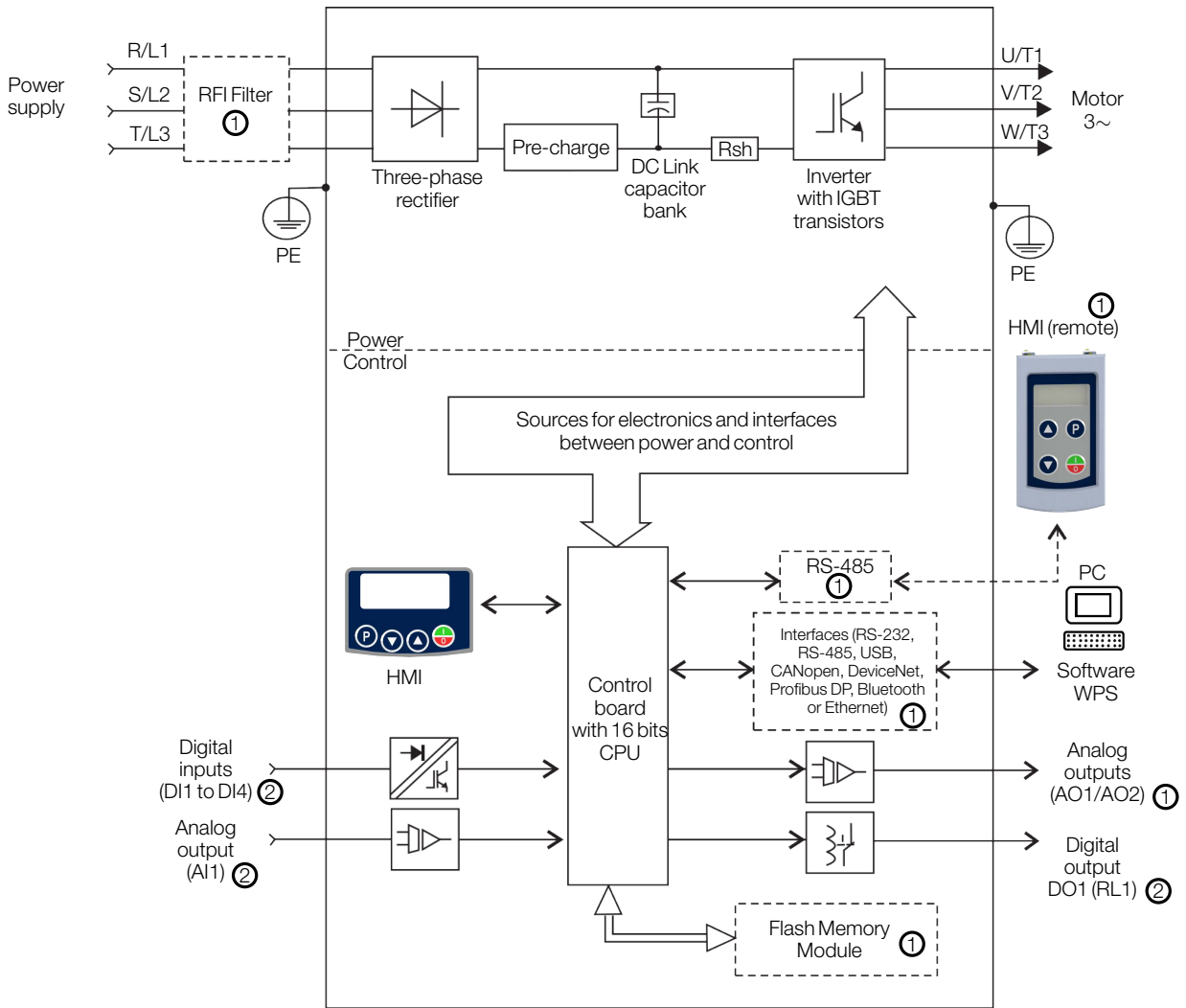

Figure 2.3: Block diagram of CFW320 for frame size B 220V



① Available as accessory.

② Inputs/Outputs available on standard product. The number of Inputs/Outputs can be expanded by using an I/O expansion module accessory.

Figure 2.4: Block diagram of CFW320 for frame size A 380-480V

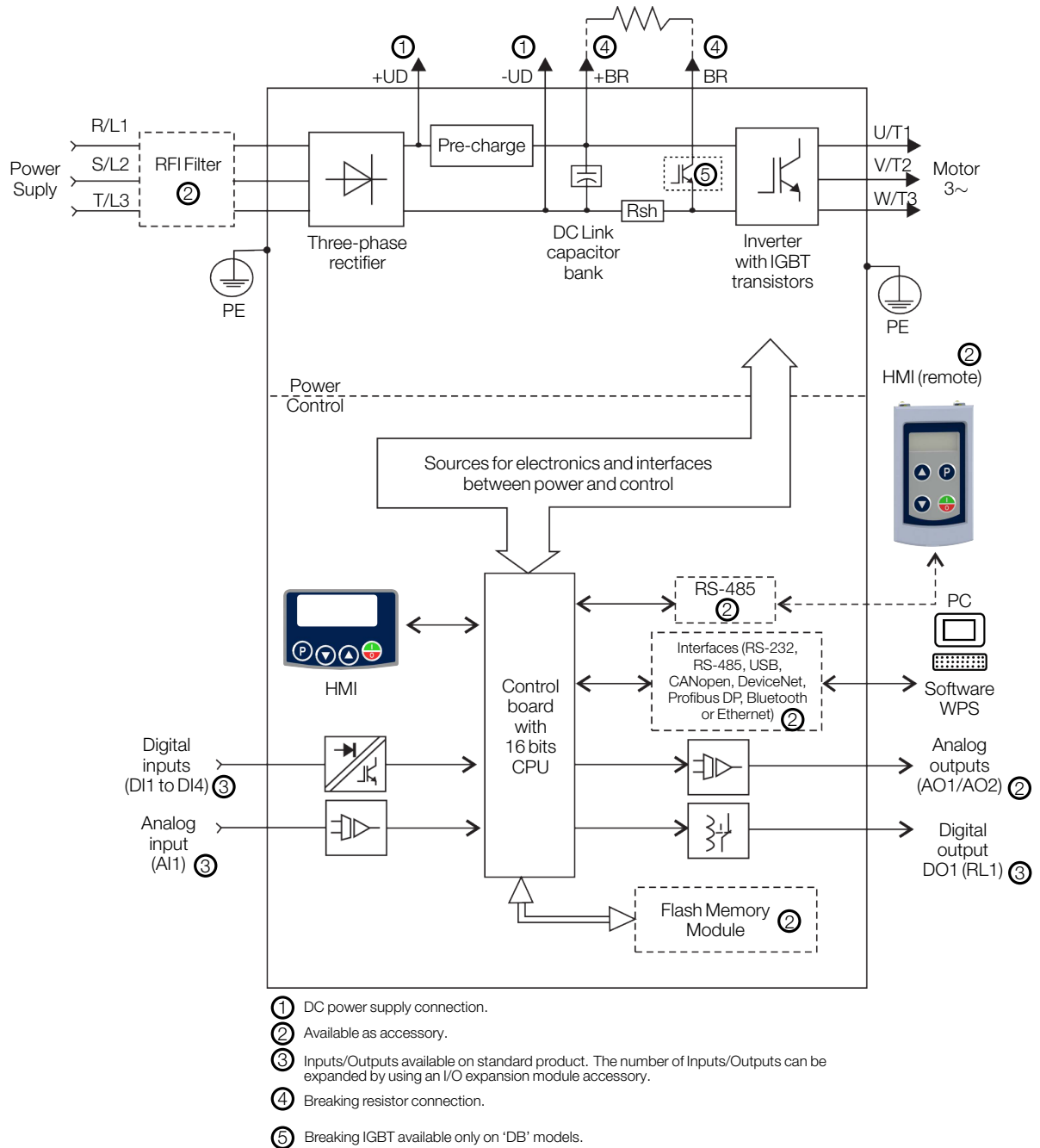

Figure 2.5: Block diagram of CFW320 for frame sizes B and C 380-480V

### 2.3 TERMINOLOGY

**Table 2.1:** Terminology of the CFW320 inverters

	Product and Series	Model identification				Brake	Degree of Protection	Special Hardware	Special Software
		Frame Size	Rated Current	Phase Number	Rated Voltage				
E.g.:	CFW320	A	01P6	S	2	NB	20	---	---
Available options	CFW320	Refer to <a href="#">Table 2.2 on page 10</a>							Blank = standard
		NB = without dynamic braking							Sx = special software
		DB = with dynamic braking							Blank = standard
		20 = IP20							Hx = special hardware

**Table 2.2:** Available options for each field of the nomenclature according to the rated current and voltage of the inverter

Frame Size	Rated Current	N° of Phases	Rated Voltage	Brake			
A	01P6 = 1.6 A	S = single-phase power supply	1 = 110...127 Vac	NB			
	02P6 = 2.6 A						
	04P2 = 4.2 A						
	06P0 = 6.0 A						
	01P6 = 1.6 A						
	02P6 = 2.6 A						
	04P2 = 4.2 A						
	06P0 = 6.0 A	2 = 200...240 Vac					
	07P3 = 7.3 A						
	01P6 = 1.6 A		T = three-phase power supply				
	02P6 = 2.6 A						
	04P2 = 4.2 A						
	06P0 = 6.0 A						
	07P3 = 7.3 A						
01P6 = 1.6 A	D = DC power supply	3 = 280...340 Vdc					
02P6 = 2.6 A							
04P2 = 4.2 A							
06P0 = 6.0 A							
07P3 = 7.3 A							
B	10P0 = 10.0 A	B = single-phase or three-phase power supply or DC power supply T = three-phase power supply or DC power supply	2 = 200...240 Vac or 280...340 Vdc	DB			
	15P2 = 15.2 A						
A	01P1 = 1.1 A	T = three-phase power supply	4 = 380...480 Vac	NB			
	01P8 = 1.8 A						
	02P6 = 2.6 A						
	03P5 = 3.5 A						
B	04P8 = 4.8 A	T = three-phase power supply or DC power supply	4 = 380...480 Vac or 513...650 Vdc		NB		
	06P5 = 6.5 A						
C	08P2 = 8.2 A				DB		
	10P0 = 10.0 A						
	12P0 = 12.0 A						
B	15P0 = 15.0 A			T = three-phase power supply or DC power supply		4 = 380...480 Vac or 513...650 Vdc	DB
	01P1 = 1.1 A						
	01P8 = 1.8 A						
	02P6 = 2.6 A						
	03P5 = 3.5 A						
	04P8 = 4.8 A						
C	06P5 = 6.5 A	DB					
	08P2 = 8.2 A						
	10P0 = 10.0 A						
C	12P0 = 12.0 A	DB					
	15P0 = 15.0 A						





**NOTE!**

- **200 V Line:** Models with power supply of 110 to 127 Vac, 200 to 240 Vac or 280 to 340 Vdc (S1, S2, B2, T2 or D3).
- **400 V Line:** Models with power supply of 380 to 480 Vac or 513 to 650 Vdc (T4)

## 2.4 IDENTIFICATION LABEL

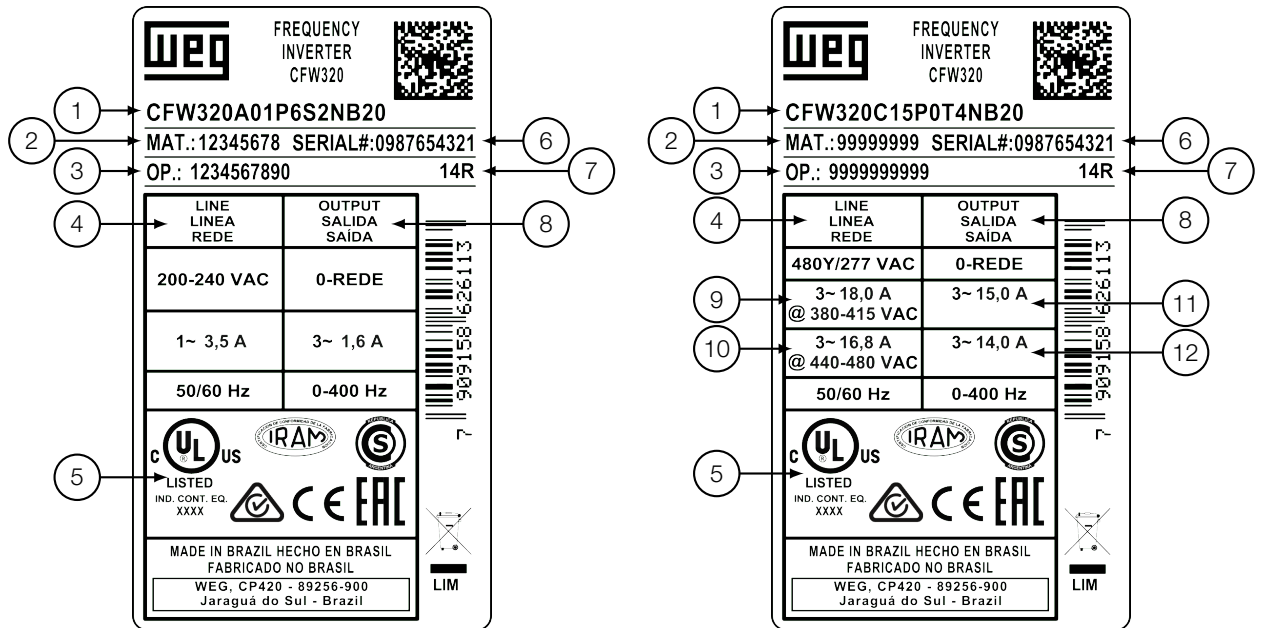
The identification label is located on the side of the inverter. For further details on positioning the label, refer to [Figure A2 on page 35](#).



(1) Model (Inverter intelligent code).

(2) WEG stock item.

(3) Production order.

(4) Rated input data (voltage, current and frequency).

(5) Certifications.

(6) Serial number.

(\*) **Voltage Range 1:** Rated currents specified for mains power supply voltages of 380-400-415 Vac (513-540-560 Vdc).

(\*\*) **Voltage Range 2:** Rated currents specified for mains power supply voltages of 440-460-480 Vac (594-621-650 Vdc).

For further details, refer to [Table B1 on page 45](#) and [Table B4 on page 51](#), and also the CFW320 programming manual.

(7) Manufacturing date (14 corresponds to the week and R to the year).

(8) Rated output data (voltage, current and frequency).

(9) Input current for voltage range 1 (\*).

(10) Input current for voltage range 2 (\*\*).

(11) Output current for voltage range 1 (\*).

(12) Output current for voltage range 2 (\*\*).

**Figure 2.6:** (a) and (b) Description of the CFW320 identification label

## 2.5 RECEIVING AND STORAGE

The CFW320 is supplied packed in a cardboard box. There is an identification label affixed to the outside of the package, identical to the one affixed to the side of the inverter.

Verify whether:

- The CFW320 identification label corresponds to the purchased model.
- Any damage occurred during transportation.

Report any damage immediately to the carrier.

If the CFW320 is not installed soon, store it in a clean and dry location (temperature between -25 °C and 60 °C (-13 °F and 140 °F)), with a cover to prevent dust accumulation inside it.

**ATTENTION!**

When the inverter is stored for a long period, it becomes necessary to perform the capacitor reforming. Refer to the procedure recommended in [Section 5.4 PREVENTIVE MAINTENANCE on page 28](#) of this manual.

### 3 INSTALLATION AND CONNECTION

#### 3.1 MECHANICAL INSTALLATION

##### 3.1.1 Environmental Conditions

**Avoid:**

- Direct exposure to sunlight, rain, high humidity or sea-air.
- Inflammable or corrosive gases or liquids.
- Excessive vibration.
- Dust, metallic particles or oil mist.

**Environment conditions permitted for the operation of the inverter:**

- Temperature around the inverter: 0 °C(32 °F) up to the rated temperature indicated in [Table B4 on page 51](#):  
**200V Line:** from 0 °C to 50 °C (32 °F to 122 °F).  
**400V Line:** from 0 °C to 40 °C (32 °F to 104 °F).
- For temperatures surrounding the inverter higher than the specifications above, it is necessary to apply a 2 % current derating for each degree Celsius (1.1 % for each degree Fahrenheit), limited to an increase of 10 °C (18 °F).
- Air relative humidity: 5 % to 95 % non-condensing.
- Maximum altitude: up to 1000 m (3.300 ft) - rated conditions.
- From 1000 m to 4000 m (3.300 ft to 13.200 ft) - 1% of current derating for each 100 m (330 ft) above 1000 m (3.300 ft) of altitude.
- From 2000 m to 4000 m (6.600 ft to 13.200 ft) above sea level - maximum voltage derating (127 V / 240 V / 480 V, according to the model, as indicated in [Table B1 on page 45](#)) of 1.1% for each 100 m (330 ft) above 2000 m (6.600 ft).
- Pollution degree: 2 (according to EN 50178 and UL 61800-5-1), with non-conductive pollution. Condensation must not originate conduction through the accumulated residues.

##### 3.1.2 Positioning and Mounting

The external dimensions and fixing holes, likewise the inverter net weight (mass) are shown in [Figure A6 on page 38](#).

Mount the inverter in the upright position on a flat and vertical surface. Allow the minimum clearances indicated in [Figure A7 on page 40](#), in order to allow the circulation of the cooling air. Do not install heat sensitive components right above the inverter.



**ATTENTION!**

- In order to comply with UL standard, use a cabinet with minimum dimensions of 150 % larger than the product dimensions shown in [Figure A6 on page 38](#) (the resulting clearance spaces around the inverter will be larger than those shown in [Figure A7 on page 40](#)). For more details, refer to [Item 3.2.3.1.1 Short Circuit Current Ratings \(SCCR\) on page 17](#) and to the [Table B3 on page 49](#).
- When installing two or more inverters vertically, respect the minimum clearance A + B (as shown in [Figure A7 on page 40](#)) and provide an air deflecting plate so that the heat rising up from the lower inverter does not affect the top inverter.
- Provide independent conduits for the physical separation of signal, control and power cables (refer to [Section 3.2 ELECTRICAL INSTALLATION on page 13](#)).

### 3.1.2.1 Cabinet Mounting

For inverters installed inside cabinets or metallic boxes, provide proper exhaustion so that the temperature remains within the allowed range. Refer to the dissipated powers in [Table B4 on page 51](#).

As a reference, [Table 3.1 on page 13](#) shows the air flow of rated ventilation for each model.

**Cooling Method:** internal fan with air flow upwards.

*Table 3.1: Air flow of internal fan*

Model	CFM	l/s	m <sup>3</sup> /min
A	17.0	8.02	0.48
B			
C	40.4	19.09	1.15

### 3.1.2.2 Surface Mounting

[Figure A6 on page 38](#) illustrates the CFW320 installation procedure for surface mounting.

### 3.1.2.3 DIN-Rail Mounting

The CFW320 inverter can also be mounted directly on a 35 mm-rail, in accordance with DIN EN 50.022. For further details, refer to [Figure A7 on page 40](#).

## 3.2 ELECTRICAL INSTALLATION



### DANGER!

- The following information is merely a guide for proper installation. Comply with applicable local regulations for electrical installations.
- Make sure the AC power supply is disconnected before starting the installation.
- The CFW320 must not be used as an emergency stop device. Provide other devices for that purpose.



### DANGER!

- Les informations suivantes constituent uniquement un guide pour une installation correcte. Respectez les réglementations locales en vigueur pour les installations électriques.
- Vérifiez que l'alimentation secteur CA est débranchée avant de commencer l'installation.
- Le CFW320 ne devra pas être utilisé comme un dispositif d'arrêt d'urgence. Utilisez des dispositifs additionnels appropriés dans ce but.



### ATTENTION!

Integral solid state short circuit protection does not provide branch circuit protection. Branch circuit protection must be provided in accordance with applicable local codes.

### 3.2.1 Identification of the Power Terminals and Grounding Points

The power terminals can be of different sizes and configurations, depending on the model of the inverter, according to [Figure A8 on page 41](#). The location of the power, grounding and control connections are shown in [Figure A8 on page 41](#).

Description of the power terminals:

- **L/L1, N/L2, L3 (R, S and T):** power supply connection.
- **U, V and W:** connection for the motor.

- **-UD:** negative pole of the DC power supply.
- **+UD:** positive pole of the DC power supply.
- **+BR, BR:** connection of the braking resistor (available for DB models).
- **PE:** grounding connection.

The maximum tightening torque of the power terminals and grounding points must be checked in [Figure A8 on page 41](#).

**DANGER!**

Observe the correct DC power supply connection, polarity and terminal positions.

**DANGER!**

Observer la bonne connexion de l'alimentation en courant continu, la polarité et l'emplacement des bornes.

### 3.2.2 Circuit Breakers, Fuses, Grounding and Power Cables

**ATTENTION!**

- Use proper cable lugs for the power and grounding connection cables. Refer to [Table B1 on page 45](#) for recommended wiring, and [Table B2 on page 47](#) and [Table B3 on page 49](#) for recommended circuit breakers and fuses.
- Keep sensitive equipment and wiring at a minimum distance of 0.25 m (9.85 in) from the inverter and from the cables connecting the inverter to the motor.



**ATTENTION!**

Residual Current Device (RCD):

- When used in the inverter supply, it must have a pick-up current of 300 mA.
- Depending on the installation conditions, such as motor cable length and type, multi-motor drive, etc., the RCD interrupter may trip. Check with the manufacturer the most suitable type for operation with inverters.

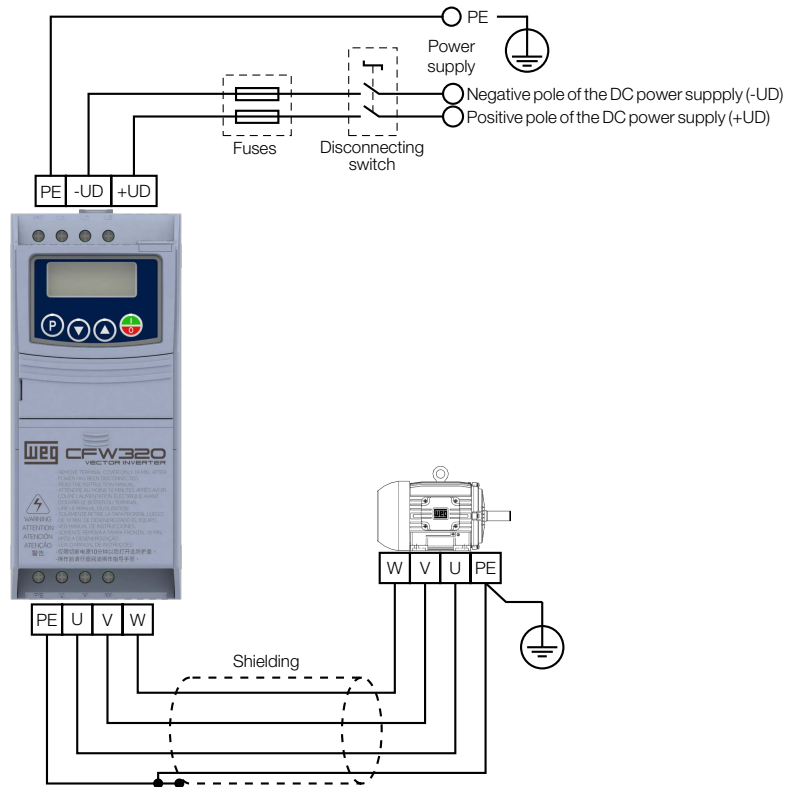

**NOTE!**

- The wire gauges listed in [Table B1 on page 45](#) are guiding values. Installation conditions and the maximum permitted voltage drop must be considered for the proper wiring sizing.
- For proper protection, use fuses or circuit breakers in the inverter power supply side with current not above the values indicated in [Table B2 on page 47](#) or [Table B3 on page 49](#). For further details, refer to the [Item 3.2.3.1.1 Short Circuit Current Ratings \(SCCR\) on page 17](#).

**3.2.3 Power Connections**

Only available for the specific models of frame A (see Table 2.2 on page 10).

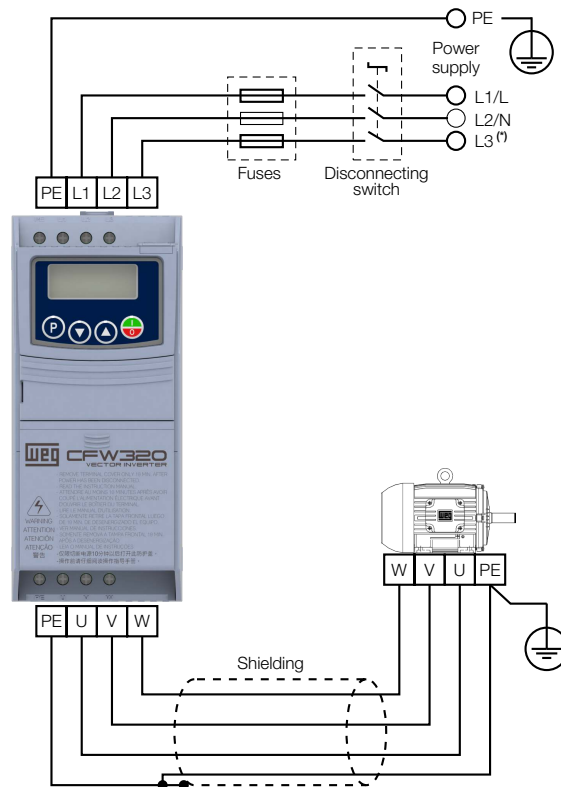
**(a) Frame size A DC power supply**



(\*) The power terminal L3 is not available in single-phase models of frame size A.

**(b) Frame size A single-phase and three-phase power supply**

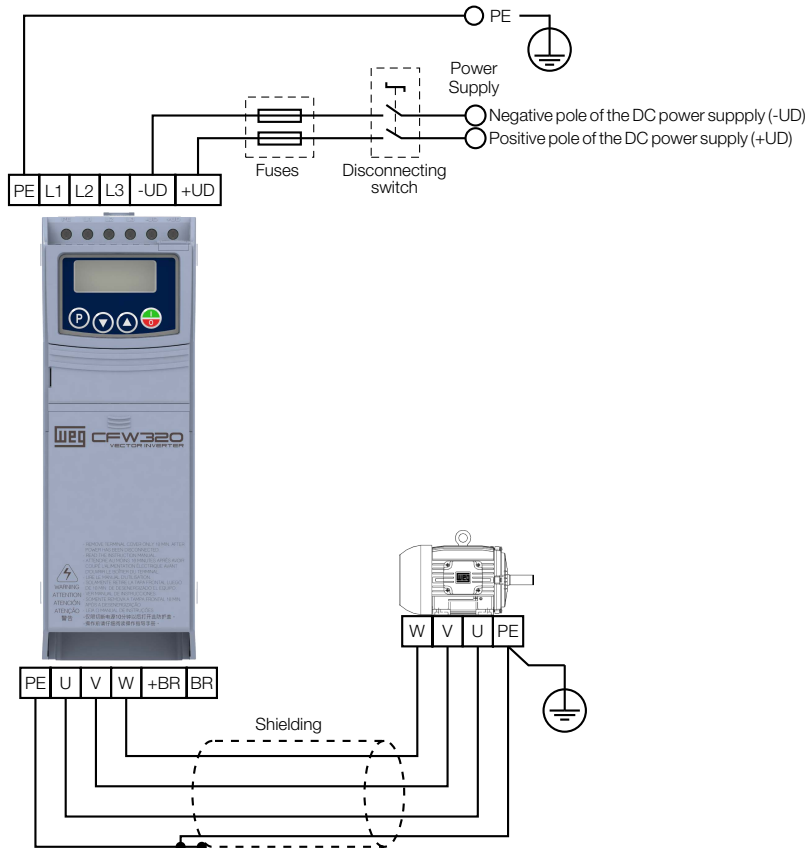

The power terminals +BR/ BR are available only on DB models.

(c) Frame sizes B and C DC power supply

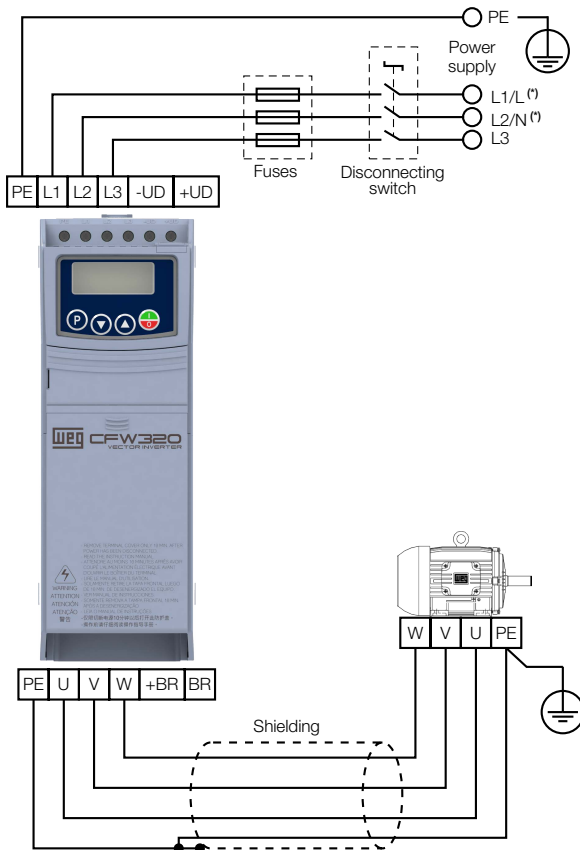

The power terminals +BR/BR are available only on DB models.

(\*) The 10 A model of the 200 V line can also be supplied by single-phase power supplies (see Table 2.2 on page 10).

(d) Frame sizes B and C three-phase power supply

Figure 3.1: (a) to (d) Power and grounding connections

### 3.2.3.1 Input Connections

**DANGER!**

Provide a disconnect device for the inverter power supply. This device must cut off the power supply whenever necessary (during maintenance for instance).

**DANGER!**

Montez un dispositif de coupure sur l'alimentation du variateur. Ce composant déconnecte l'alimentation du variateur si cela est nécessaire (ex. pendant l'entretien et la maintenance).

**ATTENTION!**

- The power supply that feeds the inverter must have a solid grounded neutral.
- The CFW320 series inverter must not be used in IT networks (where the neutral is not grounded or grounding provided by a high ohm value resistor) or in grounded delta networks ("delta corner grounded"), because these type of networks damage the inverter.

**NOTE!**

- The input power supply voltage must be compatible with the inverter rated voltage.
- Power factor correction capacitors are not needed at the input (L/L1, N/L2, L3) and must not be installed at the output (U, V, W).

#### 3.2.3.1.1 Short Circuit Current Ratings (SCCR)

- The CFW320 is suitable for use in circuits capable of delivering not more than (see column "SCCR") kArms symmetrical at (see column "Voltage") Volts Maximum, when protected by fuses or circuit breakers as specified in [Table B2 on page 47](#) or [Table B3 on page 49](#).
- For inverter's semiconductor protection, use the WEG recommended class aR semiconductor fuses, according to [Table B2 on page 47](#).
- For protection in compliance with UL standard, use the protection according to [Table B3 on page 49](#).
- In case the CFW320 is installed in power supplies with current capacity over the SCCR value specified, it is necessary to use protection circuits, such as fuses or circuit breakers, proper for those power supplies.

**ATTENTION!**

The opening of the branch-circuit protective device may be an indication that a fault current has been interrupted. To reduce the risk of fire or electric shock, current-carrying parts and other components of the inverter or cabinet should be examined and replaced if damaged. If burnout of the current element of an overload relay occurs, the complete overload relay must be replaced.

#### 3.2.3.2 Power Supply Reactance

In a general way, the inverters of the CFW320 line can be installed directly in the power supply, without reactance in the supply. However, check the following:

- In order to prevent damages to the inverter and assure the expected useful life, you must have a minimum line impedance that provides a line voltage drop of 1 %. For lower values (due to the transformers and cables), the use of a line reactance is recommended.
- For the calculation of the line reactance necessary to obtain the desired percentage voltage drop, use:

$$L = 1592 \cdot \Delta V \cdot \frac{V_e}{I_{s, rat} \cdot f} [\mu H]$$

## INSTALLATION AND CONNECTION

Where:

- $\Delta V$  - desired line drop, in percentage (%).
- $V_e$  - phase voltage in the inverter input, in volts (V).
- $I_{s, rat}$  - rated current of the inverter output.
- $f$  - line frequency.



**NOTE!**

WEG reactors available for CFW320 inverters are listed in the [Table B7 on page 55](#).

### 3.2.3.3 Dynamic Braking



**NOTE!**

The dynamic braking is available on DB models from frame size B onwards.

Refer to [Table B1 on page 45](#) for the following specifications of the dynamic braking: maximum current, minimum braking resistance, rms current (\*) and cable gauge.

(\*) The rms braking current can be calculated as follows:

$$I_{effective} = I_{max} \cdot \sqrt{\frac{t_{br(min)}}{5}}$$

Where:

$t_{br}$  - corresponds to the sum of the braking actuation times during the most severe cycle of five minutes.

The power of the brake resistor must be calculated considering the deceleration time, the inertia of the load and of the resistive torque.

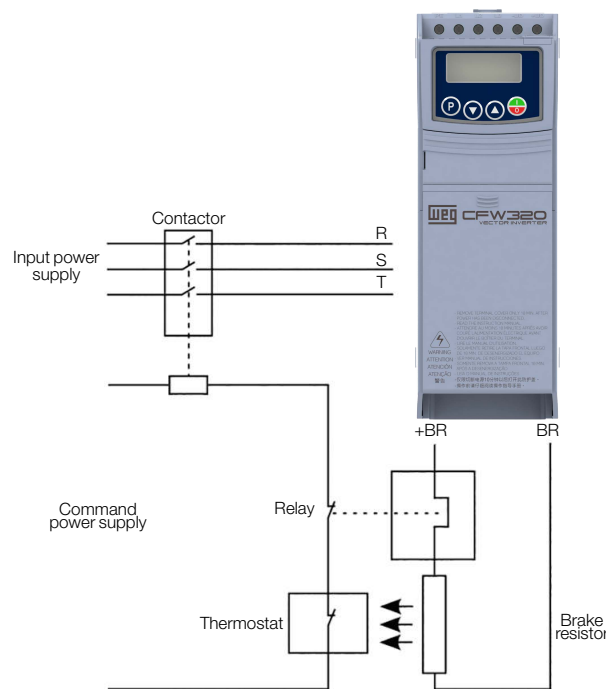

Figure 3.2: Installation of brake resistor

#### Procedure to use the dynamic braking:

- Connect the brake resistor between the power terminals +BR and BR.



- Use a twisted cable for the connection. Separate these cables from the signal and control wiring.
- Dimension the cables according to the application, observing the maximum and effective currents.
- If the brake resistor is mounted within the cabinet of the inverter, consider its energy when dimensioning the ventilation of the cabinet.

**DANGER!**

The internal braking circuit and the resistor may be damaged if the latter is not properly dimensioned and/or if the voltage of the input power supply exceeds the maximum value permitted. In order to avoid the destruction of the resistor or risk of fire, the only guaranteed method is the inclusion of a thermal relay in series with the resistor and/or a thermostat in contact with its housing, connected in such a way to disconnect the input power supply of the inverter in case of overload as shown in [Figure 3.2 on page 18](#).

**DANGER!**

Le circuit de freinage du variateur interne et la résistance de freinage peuvent être endommagés s'ils sont mal dimensionnés ou si la tension de ligne dépasse la valeur permise maximale. Dans ce cas, la seule méthode garantie pour éviter une surchauffe de la résistance de freinage et éliminer le risque d'incendie est l'installation d'un relais de surcharge thermique en série connecté avec la résistance et/ou l'installation d'un thermostat sur le corps de la résistance, en le câblant de manière à ce qu'il déconnecte l'alimentation électrique du variateur en cas de surchauffe, comme indiqué sur la [Figure 3.2 on page 18](#).

- Set P151 at maximum value when using dynamic braking.
- The voltage level on the DC link for activation of the dynamic braking is defined by the parameter P153 (level of the dynamic braking).
- Refer to the CFW320 programming manual.

### 3.2.3.4 Output Connections

**ATTENTION!**

- The inverter has an electronic motor overload protection that must be adjusted according to the driven motor. When several motors are connected to the same inverter, install individual overload relays for each motor.
- The motor overload protection available in the CFW320 is in accordance with the UL 61800-5-1 standard.

**ATTENTION!**

If a disconnect switch or a contactor is installed at the power supply between the inverter and the motor, never operate it with the motor spinning or with voltage at the inverter output.

The characteristics of the cable used to connect the motor to the inverter, as well as its interconnection and routing, are extremely important to avoid electromagnetic interference in other equipment and not to affect the life cycle of wirings and bearings of the controlled motors.

Keep motor cables away from other cables (signal cables, sensor cables, control cables, etc.) according to [Item 3.2.6 Cable Separation Distance on page 22](#).

#### When using shielded cables to install the motor:

- Follow the recommendations of IEC 60034-25.
- Use the low impedance connection for high frequencies to connect the cable shield to the grounding.

### 3.2.4 Grounding Connections



**DANGER!**

- The inverter must be connected to a protective ground (PE).
- Use a minimum wire gauge for ground connection equal to be indicated in [Table B1 on page 45](#).
- Connect the inverter grounding connections to a ground bus bar, to a single ground point or to a common grounding point (impedance  $\leq 10\Omega$ ).
- The neuter conductor of the line that feeds the inverter must be solidly grounded; however, this conductor must not be used to ground the inverter.
- Do not share the grounding wiring with the other equipment that operate with high currents (e.g.: high voltage motors, welding machines, etc.).



**DANGER!**

- Le variateur doit être raccordé à une terre de protection (PE).
- Utilisez la section minimale de raccordement à la terre indiquée dans le [Table B1 on page 45](#).
- Le couple de serrage maximal des connexions de mise à la terre est de 1.7 N.m (15 lbf.in).
- Connecter les points de mise à la terre du variateur sur une tige de mise à la terre spécifique, soit sur le point de mise à la terre spécifique soit sur le point de mise à la terre général (résistance  $\leq 10\Omega$ ).
- Le conducteur neutre qui met le convertisseur doit être neutre à la terre; cependant, ce conducteur ne doit pas être utilisé à la masse de l'onduleur.
- Ne partage pas le câblage de mise à la terre avec d'autres équipements qui fonctionnent avec des courants élevés (p. ex. les moteurs de forte puissance, machines de soudage, etc.).

### 3.2.5 Control Connections

The control connections must be made in accordance with the specification of the connector of the CFW320 control board. Functions and typical connections are presented in [Figure 3.3 on page 21](#). For further details on the specifications of the connector signals, refer to [Chapter 7 TECHNICAL SPECIFICATIONS on page 31](#).

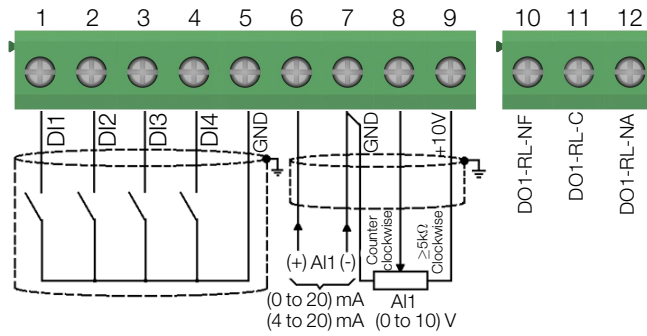

**(a) NPN Configuration**

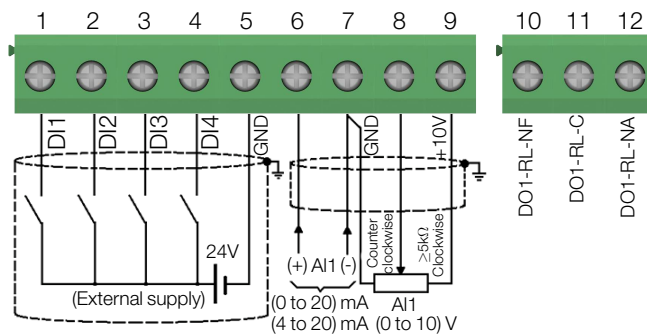

**(b) PNP Configuration**

Connector		Description (*)
1	DI1	Digital Input 1
2	DI2	Digital Input 2
3	DI3	Digital Input 3
4	DI4	Digital Input 4
5	GND	Reference 0 V
6	AI1	Analog Input 1 (Current)
7	GND	Reference 0 V
8	AI1	Analog Input 1 (Voltage)
9	+10V	Reference +10 Vdc for potentiometer
10	DO1-RL-NC	Digital Output 1 (NC contact of relay 1)
11	DO1-RL-C	Digital Output 1 (Common point of relay 1)
12	DO1-RL-NO	Digital Output 1 (NO contact of relay 1)

(\*) For further information, refer to the detailed specification in [Section 7.2 ELECTRONICS/GENERAL DATA](#) on page 32.

**Figure 3.3:** (a) and (b) Signals of C320 control card connector



**NOTE!**

- The CFW320 inverters are supplied with the digital inputs configured as active low (NPN). In order to change the configuration, check the use of parameter P271 in the programming manual of the CFW320.
- Analog input AI1 is set for input 0 to 10 V, in order to change, check parameter P233 of the programming manual.

**For the correct connection of the control, use:**

1. Gauge of the cables: 0.5 mm<sup>2</sup> (20 AWG) a 1.5 mm<sup>2</sup> (14 AWG).
2. Maximum torque: 0.3 N.m (2.65 lbf.in).
3. Wiring of the connector of the control board with shielded cable and separated from the other wiring (power, command in 110 V / 220 Vac, etc.), according to [Item 3.2.6 Cable Separation Distance](#) on page 22. If those cables must cross other cables, it must be done in perpendicular among them, keeping the minimum separation distance of 5 cm at the crossing point.

Connect the shield according to the [Figure 3.4](#) on page 22.

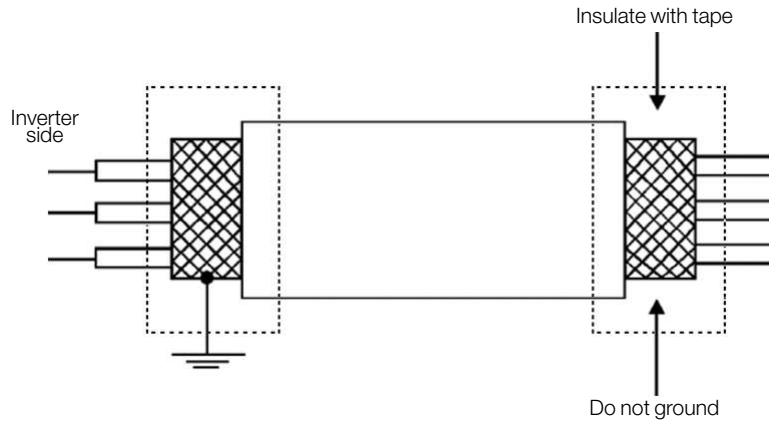

Figure 3.4: Shielding connection

4. Relays, contactors, solenoids or coils of electromechanical brake installed close to the inverters may occasionally generate interference in the control circuitry. To eliminate this effect, RC suppressors (with AC power supply) or freewheel diodes (with DC power supply) must be connected in parallel to the coils of these devices.
5. When using the external HMI (refer to [Chapter 6 ACCESSORIES on page 30](#)), the cable that connects to the inverter must be separated from the other cables in the installation, keeping a minimum distance of 10 cm (3.95 in).

### 3.2.6 Cable Separation Distance

Provide separation between the control and the power cables according to [Table 3.2 on page 22](#)

Table 3.2: Separation distance between cables

Output Rated Current of the inverter	Cable Length	Minimum Separation Distance
≤ 24 A	≤ 100m (330 ft)	≥ 10 cm (3.94 in)
	> 100 m (330 ft)	≥ 25 cm (9.84 in)

## 3.3 INSTALLATIONS ACCORDING TO EUROPEAN DIRECTIVE OF ELECTROMAGNETIC COMPATIBILITY

The CFW320 inverters feature external RFI filter to reduce electromagnetic interference (refer to [Chapter 6 ACCESSORIES on page 30](#)). Those inverters, when properly installed, meet the requirements of the electromagnetic compatibility (EMC) directive (2014/30/EU).

These inverters were developed for professional applications only. Therefore, the limits for emission of harmonic currents established by the EN 61000-3-2 and EN 61000-3-2/A 14 standards are not applicable.

### 3.3.1 Control Connections

1. Shielded output cables (motor cables) with the shield connected at both ends, motor and inverter, with low-impedance connection or high frequency. Maximum motor cable length and conducted and radiated emission levels according to [Table B5 on page 53](#).
2. Shielded control cables, and keep them away from other cables according to [Table 3.2 on page 22](#).
3. Grounding of the inverter according to instructions of [Item 3.2.4 Grounding Connections on page 20](#).
4. Grounded power supply.
5. Use short wiring to ground the external filter or inverter.
6. Ground the mounting plate using a flexible braid as short as possible. Flat conductors have lower impedance at high frequencies.

7. Use cord grips for strain relief on conduits.

### 3.3.2 Emission and Immunity Levels

**Table 3.3:** Emission and immunity levels

EMC Phenomenon	Basic Standard	Level
Emission:		
Mains Terminal Disturbance Voltage Frequency range: 150 kHz to 30 MHz)	IEC/EN 61800-3	It depends on the inverter model and also on the length of the motor cable. Refer to <a href="#">Table B5 on page 53</a> .  <b>C3:</b> Frame size B models of 200 V Line (CFW320B10P0B2 and CFW320B15P2T2) require a cabinet with a minimum attenuation of 12dB.
Electromagnetic Radiation Disturbance Frequency range: 30 MHz to 1000 MHz)		
Immunity:		
Electrostatic Discharge (ESD)	IEC 61000-4-2	4 kV for contact discharge and 8kV for air discharge
Fast Transient-Burst	IEC 61000-4-4	2 kV / 5 kHz (coupling capacitor) input cables 1 kV / 5 kHz control cables and remote HMI cables 2 kV / 5 kHz (coupling capacitor) motor cables
Conducted Radio-Frequency Common Mode	IEC 61000-4-6	0,15 a 80 MHz; 10 V; 80 % AM (1 kHz) Motor, control and remote HMI cables
Surges	IEC 61000-4-5	1,2/50 $\mu$ s, 8/20 $\mu$ s 1 kV line-to-line coupling 2 kV line-to-ground coupling
Radio-Frequency Electromagnetic Field	IEC 61000-4-3	80 a 1000 MHz 10 V/m 80 % AM (1 kHz)

#### Definition of Standard IEC/EN 61800-3: “Adjustable Speed Electrical Power Drives Systems”

##### ■ Environments:

**First Environment:** environments that include domestic installations, as well as establishments directly connected without intermediate transformer to a low-voltage power supply network which supplies buildings used for domestic purposes.

**Second Environment:** includes all establishments other than those directly connected to a low-voltage power supply network that supplies buildings used for domestic purposes.

##### ■ Categories:

**Category C1:** inverters with a voltage rating less than 1000 V and intended for use in the First Environment.

**Category C2:** inverters with a voltage rating less than 1000 V intended for use in the First Environment, not provided with a plug connector or movable installations. They must be installed and commissioned by a professional.

**Category C3:** inverters with a voltage rating less than 1000 V and intended for use in the Second Environment only (not designed for use in the First Environment).



##### **NOTE!**

A professional is a person or organization familiar with the installation and/or commissioning of inverters, including their EMC aspects.

### 3.3.3 Characteristics of the RFI Filter

CFW320 inverters, when installed with external filter, comply with the directive for electromagnetic compatibility (2014/30/EU). The use of RFI filter kit indicated in the [Table 6.1 on page 30](#), or equivalent, is required to reduce the disturbance conducted from the inverter to the power line in the high frequency band (> 150 kHz) observing the maximum conducted emission levels of electromagnetic compatibility standards, such as EN 61800-3.

For further details, refer to [Section 3.3 INSTALLATIONS ACCORDING TO EUROPEAN DIRECTIVE OF ELECTROMAGNETIC COMPATIBILITY on page 22](#).

For further information about the RFI filter model, refer to [Table 6.1 on page 30](#).

The [Figure 3.5 on page 24](#) demonstrates the connection of the RFI filter kit accessory to the inverter:

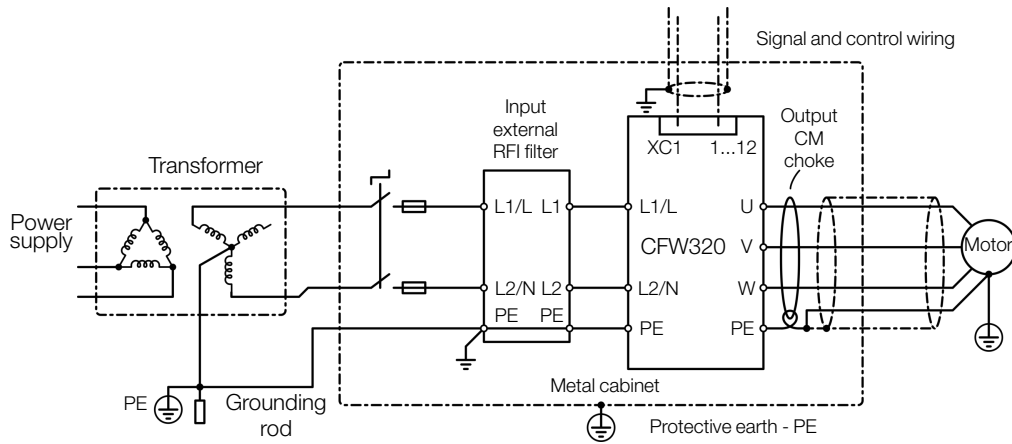

**(a) Connection of the single-phase RFI filter**

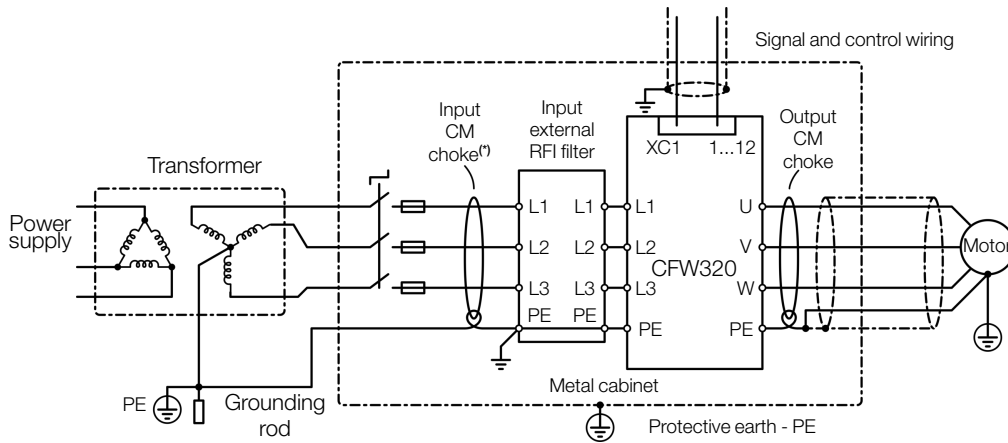

(\*) Input CM Choke only on required models, according to [Table 6.1](#) - please refer to the RFI filter kit installation guide.

**(b) Connection of the three-phase RFI filter**

**Figure 3.5:** (a) and (b) Connection of the RFI filter - general conditions

## 4 KEYPAD (HMI) AND BASIC PROGRAMMING

### 4.1 USE OF THE KEYPAD TO OPERATE THE INVERTER

Through the HMI, it is possible to command the inverter, visualize and adjust all of its parameters. The Keypad features the following functions:

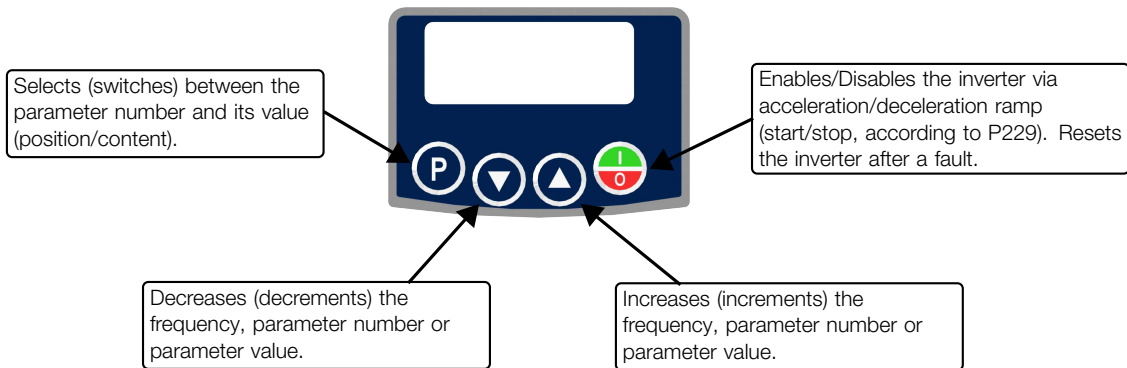

Figure 4.1: HMI keys

### 4.2 INDICATIONS ON THE HMI DISPLAY

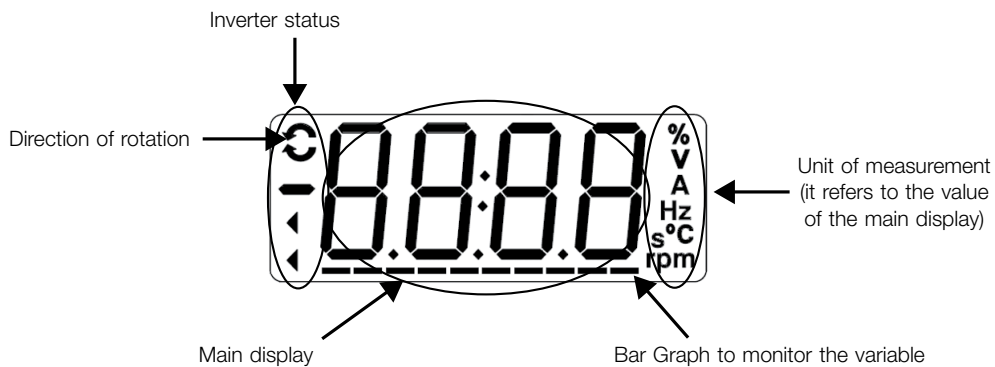

Figure 4.2: Display areas

### 4.3 OPERATING MODES OF THE HMI

When energizing the inverter, the initial state of the keypad remains in the initialization mode as long as there is no fault, alarm, undervoltage or any key is pressed.

The setting mode is composed of two levels: Level 1 allows the navigation through the parameters. And level 2 allows the edition of the parameter selected at level 1. At the end of this level, the modified value is saved when the key **P** is pressed.

Figure 4.3 on page 26 illustrates the basic browsing of the operating modes of the HMI.

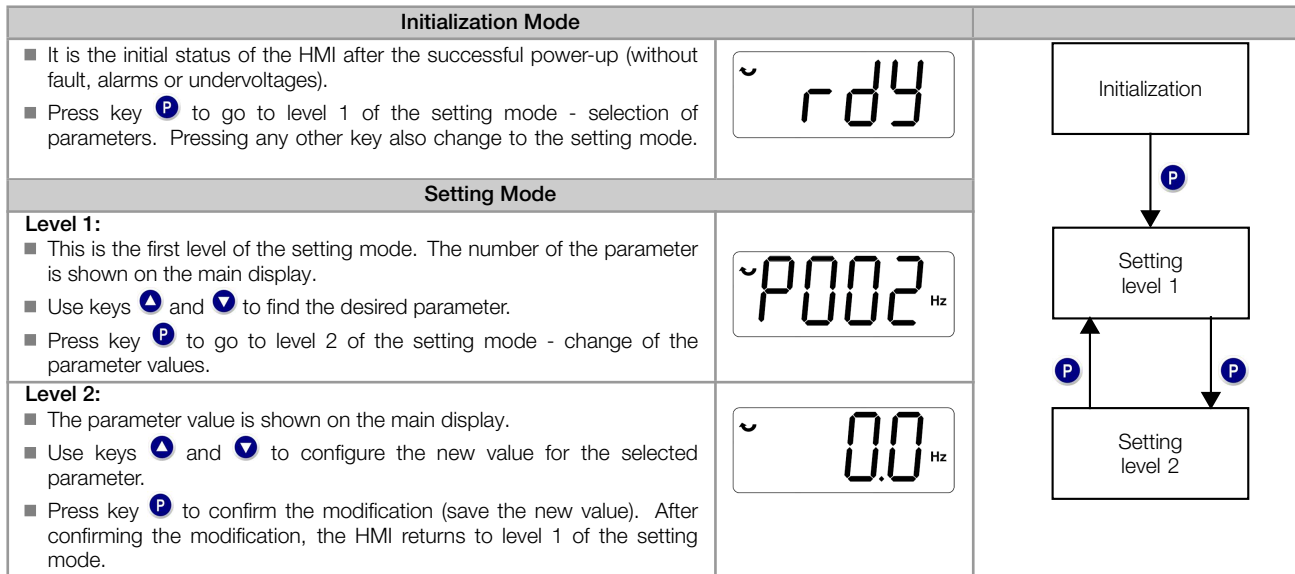

*Figure 4.3: HMI operating modes*



**NOTE!**

When the inverter is in the fault state, the main display indicates the number of the fault in the format **Fxxx**. Navigation is allowed after activation of key **P**.



**NOTE!**

When the inverter is in the alarm state, the main display indicates the number of the alarm in the format **Axxx**. The navigation is allowed after the activation of key **P**; thus, the indication **"A"** goes to the unit of measurement display until the situation causing the alarm is solved.



**NOTE!**

A list of parameters is presented in the quick reference of the parameters. For further information about each parameter, refer to the CFW320 programming manual.



## 5 TROUBLESHOOTING AND MAINTENANCE

### 5.1 FAULTS AND ALARMS

**NOTE!**

Refer to the CFW320 quick reference and the programming manual for further information on each fault or alarm.

### 5.2 SOLUTION FOR THE MOST FREQUENT PROBLEMS

*Table 5.1: Solution for the most frequent problems*

Problem	Point to be Verified	Corrective Action
Motor will not start	Incorrect wiring	1. Check all power and control connections
	Analog reference (if used)	1. Check if the external signal is properly connected 2. Check the status of the control potentiometer (if used)
	Incorrect settings	1. Check if the parameter values are correct for the application
	Fault	1. Check whether the inverter is disabled due to a fault condition
	Motor stall	1. Decrease the motor overload 2. Increase P136, P137 (V/f)
Motor speed oscillates	Loose connections	1. Stop the inverter, turn off the power supply, check and tighten all the power connections 2. Check all the internal connections of the inverter
	Defective speed reference potentiometer	1. Replace the potentiometer
	Oscillation of the external analog reference	1. Identify the cause of the oscillation. If the cause is electrical noise, use shielded cables or separate them from the power or command wiring 2. Interconnect the GND of the analog reference to the grounding connection of the inverter
Too high or too low motor speed	Incorrect settings (reference limits)	1. Check whether the values of P133 (minimum speed) and P134 (maximum speed) are properly set for the used motor and application
	Control signal of the analog reference (if used)	1. Check the level of the reference control signal 2. Check the setting (gain and offset) of parameters P232 to P240
	Motor nameplate	1. Check whether the used motor matches the application
Display is off	HMI connections	1. Check the connections of the inverter external HMI
	Power supply voltage	1. Rated values must be within the limits specified below: <b>200 V Line:</b> 110 - 127 V power supply: Mín: 93 V to Máx: 140 V 200 - 240 V power supply: Mín: 170 V to Máx: 264 V <b>400 V Line:</b> 380 - 480 V power supply: Mín: 323 V to Máx: 528 V
	Main supply fuses open	1. Replace the fuses

**5.3 INFORMATION NECESSARY FOR CONTACTING TECHNICAL SUPPORT**

For technical support or servicing, it is important to have the following information in hand:

- Inverter model.
- Serial number and manufacturing date listed in the product nameplate (refer to [Section 2.4 IDENTIFICATION LABEL on page 11](#)).
- Installed Software version (refer to P023).
- Data on the application and inverter settings.

**5.4 PREVENTIVE MAINTENANCE**



**DANGER!**  
 Always turn off the mains power supply before touching any electrical component associated to the inverter.  
 High voltages may still be present even after disconnecting the power supply.  
 To prevent electric shock, wait at least ten minutes after turning off the input power for the complete discharge of the power capacitors. Always connect the equipment frame size to the protective ground (PE). Use the adequate connection terminal at the inverter.



**DANGER!**  
 Toujours couper l'alimentation électrique avant de toucher les composants électriques de l'onduleur. Des hautes tensions peuvent encore être présentes même après la déconnexion de l'alimentation. Pour éviter tout choc électrique, attendez au moins 10 minutes après la mise hors tension de la puissance d'entrée pour la décharge complète de la puissance des condensateurs. Branchez toujours l'équipement Taille de cadre à la terre de protection (PE). Utilisez la borne de connexion adéquat à l'onduleur.



**ATTENTION!**  
 The electronic boards have electrostatic discharge sensitive components.  
 Do not touch the components or connectors directly. If necessary, first touch the grounded metallic frame size or wear a ground strap.  
 Do not perform any withstand voltage test: if necessary, consult WEG.

The inverters require low maintenance when properly installed and operated. [Table 5.2 on page 28](#) presents the main procedures and time intervals for preventive maintenance. [Table 5.3 on page 29](#) provides recommended periodic inspections to be performed every 6 months after the inverter start-up.

*Table 5.2: Preventive maintenance*

Maintenance		Interval	Instructions
Fan replacement		After 40.000 operating hours	Replacement
Electrolytic capacitors	If the inverter is stocked (not being used): "Reforming"	Every year from the manufacturing date printed on the inverter identification label (refer to <a href="#">Section 2.5 RECEIVING AND STORAGE on page 11</a> )	Apply power to the inverter according to the model of inverter (voltage between 220 and 230 Vac, single-phase/three-phase or DC, 50 or 60Hz) for at least one hour. Then, disconnect the power supply and wait at least 24 hours before using the inverter (reapply power)
	Inverter is being used: replace	Every 10 years	Contact WEG technical support to obtain replacement procedures

**Table 5.3:** Recommended periodic inspections - every 6 months

Component	Abnormality	Corrective Action
Terminals, connectors	Loose screws	Tighten
	Loose connectors	
Fans / Cooling systems (*)	Dirty fans	Clean
	Abnormal acoustic noise	Replace the fan
	Blocked fan	Clean or replace
	Abnormal vibration	
	Dust in the cabinet air filter	
Printed circuits boards	Accumulation of dust, oil, humidity, etc.	Clean
	Odor	Replace
Power module / Power connections	Accumulation of dust, oil, humidity, etc.	Clean
	Loose connections screws	Tighten
DC Link Capacitors	Discoloration / odor / electrolyte leakage	Replace
	Expanded or broken safety valve	
	Frame size expansion	
Power resistors	Discoloration	Replace
	Odor	
Heatsink	Accumulation of dust	Clean
	Dirt	

(\*) The CFW320 fan can be easily replaced as shown in [Figure A5 on page 37](#).

## 5.5 CLEANING INSTRUCTIONS

When it is necessary to clean the inverter, follow the instructions below:

Ventilation system:

- Disconnect the inverter power supply and wait for 10 minutes.
- Remove the dust from the cooling air inlet by using a soft brush or cloth.
- Remove the dust from the fan blades by using compressed air.

Cards:

- Disconnect the power supply of the inverter and wait for 10 minutes.
- Disconnect all the cables of the inverter, identifying all of them in order to reconnect them correctly.
- Remove the plastic cover and the plug-in module (refer to [Chapter 3 INSTALLATION AND CONNECTION on page 12](#) and [APPENDIX B - TECHNICAL SPECIFICATIONS on page 45](#)).
- Remove the dust accumulated on the cards using an anti-static brush using and/or ion compressed air gun.
- Always use grounding strap.

## 6 ACCESSORIES

The accessories are hardware resources that can be added to the application. Thus, all models can receive all the presented options, except the RFI filters, which must be selected according to the type of inverter power supply (please refer to the [Table 6.1](#)).

The accessories are installed in the inverters easily and quickly using the “Plug and Play” concept. The accessory must be installed or modified with the inverter power supply off. They may be ordered separately, and will be shipped in individual packages.

The CFW320 inverters have two slots for simultaneous connection of the accessories:

Slot 1 - Communication accessory or external HMI (see [Figure A3 on page 36](#)).

Slot 2 - Input and output (I/O) expansion accessory (see [Figure A4 on page 36](#)).

**Table 6.1:** Accessory models

WEG Item	Name	Description
<b>Communication Accessories</b>		
16047140	CFW320-CRS485	RS-485 communication module
16047139	CFW320-CUSB	USB communication module (2 m cable attached)
16047141	CFW320-CRS232	RS-232 communication module
16047144	CFW320-CCAN	CANopen and DeviceNet communication module
16047208	CFW320-CPDP	Profibus DP communication module
16047096	CFW320-IOP	Potentiometer reference module
16047209	CFW320-CETH	Ethernet communication module
<b>Input and Output (I/O) Expansion Accessory</b>		
16046977	CFW320-IOAR	Input and output expansion module: 1 analog input, 1 analog output and 3 relays outputs
16047089	CFW320-IODR	Input and output expansion module: 4 digital inputs and 3 relays outputs
16046971	CFW320-IOAENC	Input and output expansion module: 1 analog input, 2 analog outputs and input for incremental encoder
16047092	CFW320-IOADR	Input and output expansion module with remote control: 1 NTC input, 3 relay outputs and 1 input for infrared sensor (infrared sensor, NTC and remote control with battery included)
16047095	CFW320-IOADR-D	Input and output expansion module with remote control: 1 NTC input, 3 relay outputs and 1 input for infrared sensor (infrared sensor, NTC and remote control with display)
16046973	CFW320-IODF	Input and output expansion module for Multipump application: 3 frequency digital inputs, 3 frequency digital outputs
<b>External HMI</b>		
16047211	CFW320-KHMIR	CFW320 remote HMI kit (CFW320-CRS485 + 3m cable attached)
<b>Flash Memory Module</b>		
13014693	MMF-uDRIVES	Flash Memory Module (1 m cable attached) <sup>(3)</sup>
<b>RFI Filter Accessory</b>		
16423413	CFW320-KFA-S1-S2	RFI filter kit CFW320 frame A single-phase (200 V Line) <sup>(1)</sup>
16423862	CFW320-KFB-S2	RFI filter kit CFW320 frame B single-phase (200 V Line) <sup>(1)</sup>
16047216	CFW320-KFA-T2	RFI filter kit CFW320 frame A three-phase (200 V Line) <sup>(1)</sup>
16047260	CFW320-KFB-T2	RFI filter kit CFW320 frame B three-phase (200 V Line) <sup>(1)</sup>
16047263	CFW320-KFA-T4	RFI filter kit CFW320 frame A three-phase (400 V Line) <sup>(1)</sup>
16047265	CFW320-KFB-T4	RFI filter kit CFW320 frame B three-phase (400 V Line) <sup>(2)</sup>
16047266	CFW320-KFC-T4	RFI filter kit CFW320 frame C three-phase (400 V Line) <sup>(2)</sup>

<sup>(1)</sup> Accessory kit provided with: RFI Filter, connecting bars and 1 common mode choke for motor cables.

<sup>(2)</sup> Accessory kit provided with: RFI Filter, connecting bars and 2 common mode chokes, for motor and supply cables.

## 7 TECHNICAL SPECIFICATIONS

### 7.1 POWER DATA

Power Supply:

- Voltage Tolerance: -15 % to 10 % of nominal voltage.
- Frequency: 50/60 Hz (48 Hz to 62 Hz).
- Phase imbalance:  $\leq 3$  % of the rated phase-to-phase input voltage.
- Overvoltage according to Category III (EN 61010/UL 61800-5-1).
- Transient voltages according to Category III.
- Maximum of 10 connections per hour (1 every 6 minutes).
- Typical efficiency:  $\geq 97$  %.
- Classification of chemically active substances: level 3C2.
- Mechanical condition rating (vibration): level 3M4.
- Audible noise level:  $< 60$ dB.

For further information about technical specifications, refer to [APPENDIX B - TECHNICAL SPECIFICATIONS](#) on page 45.

## 7.2 ELECTRONICS/GENERAL DATA

**Table 7.1:** Electronics/general data

Control	Method	<ul style="list-style-type: none"> <li>■ Types of control:                             <ul style="list-style-type: none"> <li>- V/f (Scalar)</li> <li>- VVW: voltage vector control</li> </ul> </li> <li>■ Modulação:                             <ul style="list-style-type: none"> <li>- PWM SVM (Space Vector Modulation)</li> </ul> </li> </ul>
	Output frequency	<ul style="list-style-type: none"> <li>■ 0 to 400 Hz, resolution de 0.1 Hz</li> </ul>
Performance	Speed Control	<p><b>V/f (Scalar):</b></p> <ul style="list-style-type: none"> <li>■ Speed regulation: 1 % of the rated speed (with slip compensation)</li> <li>■ Speed variation range: 1:20</li> </ul> <p><b>VVW:</b></p> <ul style="list-style-type: none"> <li>■ Speed regulation: 1 % of the rated speed</li> <li>■ Speed variation range: 1:30</li> </ul>
Inputs	Analog	<ul style="list-style-type: none"> <li>■ 1 insulated input. Levels: (0 to 10) V or (0 to 20) mA or (4 to 20) mA</li> <li>■ Linearity error <math>\leq 0.25\%</math></li> <li>■ Impedance: 100 k<math>\Omega</math> for voltage input, 500 <math>\Omega</math> for current input</li> <li>■ Programmable functions</li> <li>■ Maximum voltage permitted in the input: 30 Vdc</li> </ul>
	Digital	<ul style="list-style-type: none"> <li>■ 4 isolated inputs</li> <li>■ Programmable functions:                             <ul style="list-style-type: none"> <li>- active high (PNP): maximum low level of 10 Vdc minimum high level of 20 Vdc</li> <li>- active low (NPN): maximum low level of 5 Vdc minimum high level of 10 Vdc</li> </ul> </li> <li>■ Maximum input voltage of 30 Vdc</li> <li>■ Input current: 11 mA</li> <li>■ Maximum input current: 20 mA</li> </ul>
Outputs	Relays	<ul style="list-style-type: none"> <li>■ 1 relay with NO/NC contact</li> <li>■ Maximum voltage: 250 Vac</li> <li>■ Maximum current: 0.5 A</li> <li>■ Programmable functions</li> </ul>
	Power supply	<ul style="list-style-type: none"> <li>■ 10 Vdc power supply. Maximum capacity: 50 mA</li> </ul>
Safety	Protection	<ul style="list-style-type: none"> <li>■ Overcurrent/phase-phase short circuit in the output</li> <li>■ Under/overvoltage</li> <li>■ Motor overload</li> <li>■ Overtemperature in the power module (IGBTs)</li> <li>■ Fault/external alarm</li> <li>■ Programming error</li> </ul>
Integral keypad (HMI)	Standard keypad	<ul style="list-style-type: none"> <li>■ 4 keys: Start/Stop, Up arrow, Down arrow and Programming</li> <li>■ LCD Display</li> <li>■ View/edition of all parameters</li> <li>■ Indication accuracy:                             <ul style="list-style-type: none"> <li>- current: 10 % of the rated current</li> <li>- speed resolution: 0.1 Hz</li> </ul> </li> </ul>
Enclosure	IP20	<ul style="list-style-type: none"> <li>■ Frames sizes A, B and C</li> </ul>

**7.2.1 Considered Standards**
*Table 7.2: Considered standards*

Safety standards	<ul style="list-style-type: none"> <li>■ UL 61800-5-1 - adjustable speed electrical power drive systems - Part 5-1: Safety requirements - electrical, thermal and energy</li> <li>■ EN 61800-5-1 - safety requirements electrical, thermal and energy</li> <li>■ EN 50178 - electronic equipment for use in power installations</li> <li>■ EN 60204-1 - safety of machinery. Electrical equipment of machines. Part 1: general requirements</li> </ul> <p><b>Note:</b> the final assembler of the machine is responsible for installing a safety stop device and a supply disconnecting device</p> <ul style="list-style-type: none"> <li>■ EN 60146 (IEC 146) - semiconductor converters</li> <li>■ EN 61800-2 - adjustable speed electrical power drive systems - part 2: general requirements - rating specifications for low voltage adjustable frequency AC power drive systems</li> </ul>
Electromagnetic compatibility (EMC) standards (*)	<ul style="list-style-type: none"> <li>■ EN 61800-3 - adjustable speed electrical power drive systems - part 3: EMC product standard including specific test methods</li> <li>■ CISPR 11 - industrial, scientific and medical (ISM) radio-frequency equipment - electromagnetic disturbance characteristics - limits and methods of measurement</li> <li>■ EN 61000-4-2 - electromagnetic compatibility (EMC) - part 4: testing and measurement techniques - section 2: electrostatic discharge immunity test</li> <li>■ EN 61000-4-3 - electromagnetic compatibility (EMC) - part 4: testing and measurement techniques - section 3: radiated, radio-frequency, electromagnetic field immunity test.</li> <li>■ EN 61000-4-4 - electromagnetic compatibility (EMC) - part 4: testing and measurement techniques - section 4: electrical fast transient/burst immunity test</li> <li>■ EN 61000-4-5 - electromagnetic compatibility (EMC) - part 4: testing and measurement techniques - section 5: surge immunity test</li> <li>■ EN 61000-4-6 - electromagnetic compatibility (EMC) - part 4: testing and measurement techniques - section 6: immunity to conducted disturbances, induced by radio-frequency fields</li> </ul>
Mechanical standards	<ul style="list-style-type: none"> <li>■ EN 60529 - degrees of protection provided by enclosures (IP code)</li> <li>■ UL 50 - enclosures for electrical equipment</li> <li>■ IEC 60721-3-3 - classification of environmental conditions - part 3: classification of groups of environmental parameters and their severities - section 3: stationary use at weather protected locations level</li> </ul>

(\*) Compliance with standards upon installation of external RFI filter. See [Chapter 3 INSTALLATION AND CONNECTION](#) on page 12.

## APPENDIX A - FIGURES

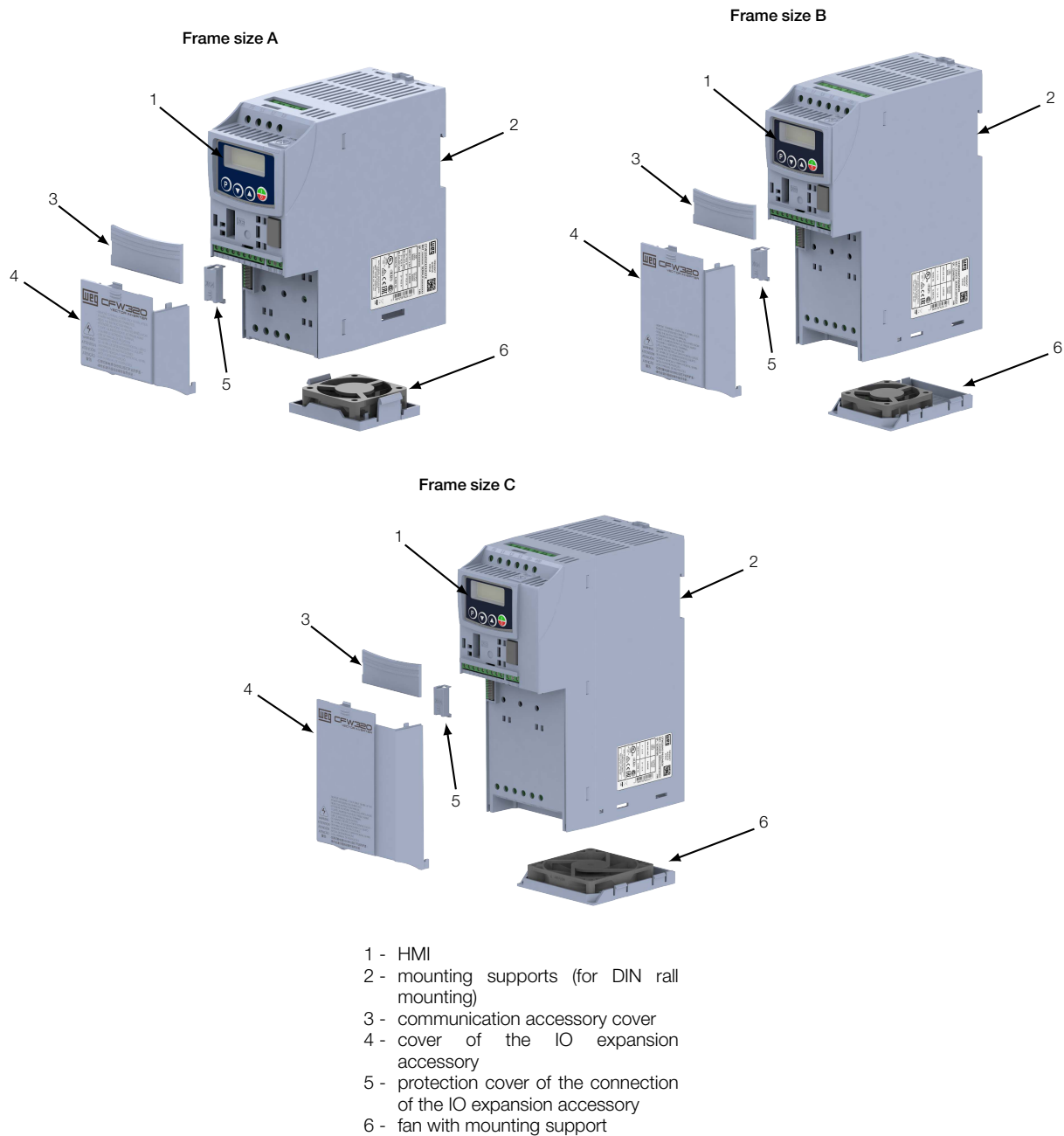

**Figure A1:** Main components of the CFW320





1 - Nameplate affixed to the side of the inverter

**Figure A2:** Location of the nameplate

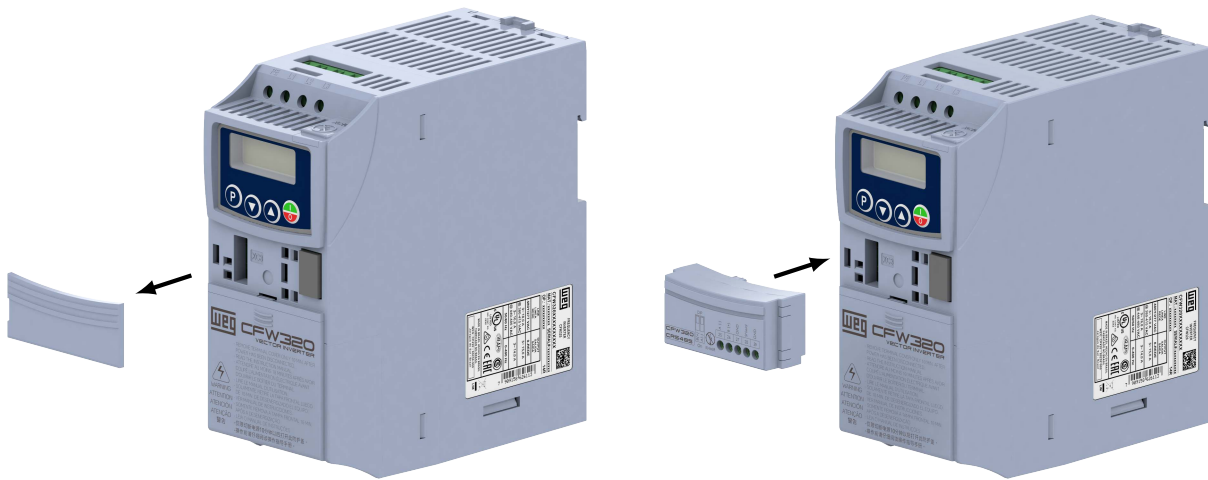

(a) Removal of the communication accessory cover

(b) Accessory connection

Figure A3: (a) and (b) Slot 1 Communication accessory or external HMI

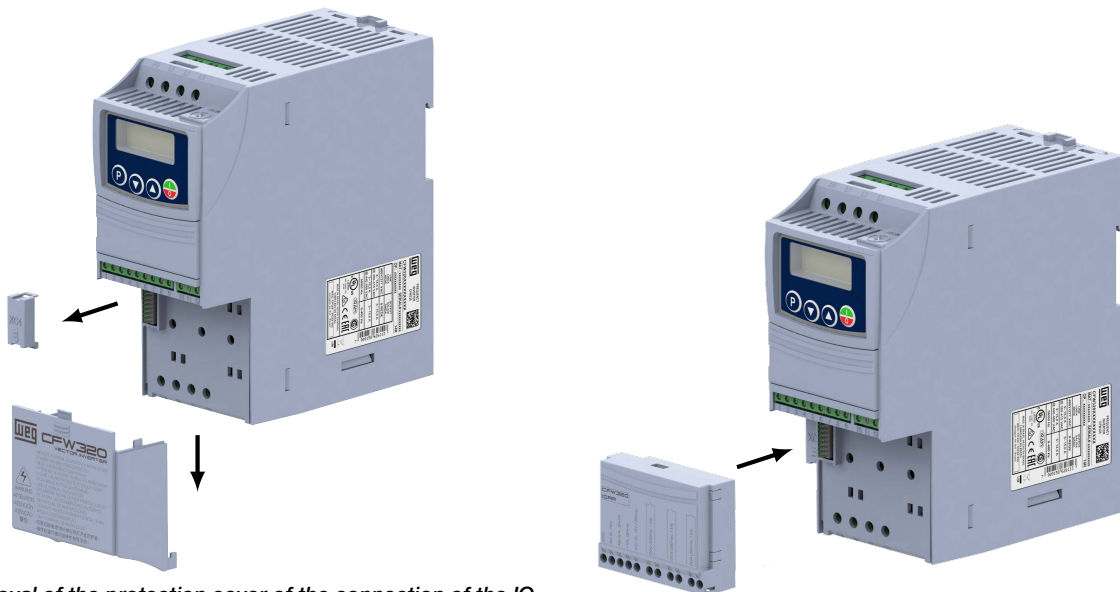

(a) Removal of the protection cover of the connection of the IO expansion accessory

(b) Accessory connection

Figure A4: (a) and (b) Slot 2 Input and output (I/O) expansion accessory

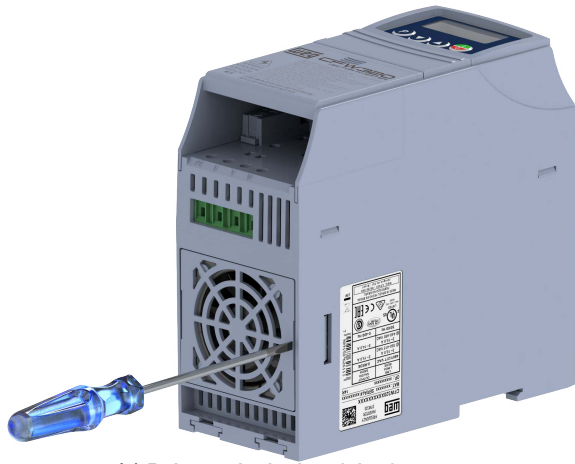

(a) Release the locks of the fan cover



(b) Removal of the fan

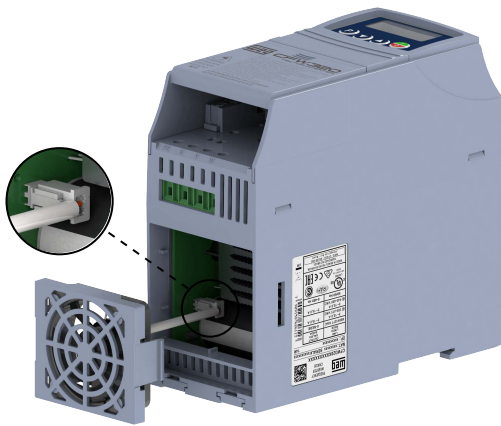

(c) Cable disconnection



(d) Cable disconnected

Figure A5: (a) to (d) Removal of the heatsink



Frame size	A	B	H	L	P	Weight	Mounting Bolt	Recommended Torque
	mm (in)	mm (in)	mm (in)	mm (in)	mm (in)			N.m. (lbf.in)
A	35.0 (1.37)	50.1 (1.97)	157.9 (6.22)	70.0 (2.76)	148.4 (5.84)	0.900 (1.98)	M4	2 (17.7)
B	35.0 (1.37)	50.1 (1.97)	198.9 (8.08)	70.0 (2.76)	158.4 (6.24)	1.340 (2.95)	M4	2 (17.7)
C	44.5 (1.75)	50.1 (1.97)	214.0 (8.43)	89.0 (3.50)	164.0 (6.45)	1.50 (3.3)	M4	2 (17.7)

Dimension tolerance: ±1.0 mm (±0.039 in)

Figure A6: Frequency inverter dimensions for mechanical installation

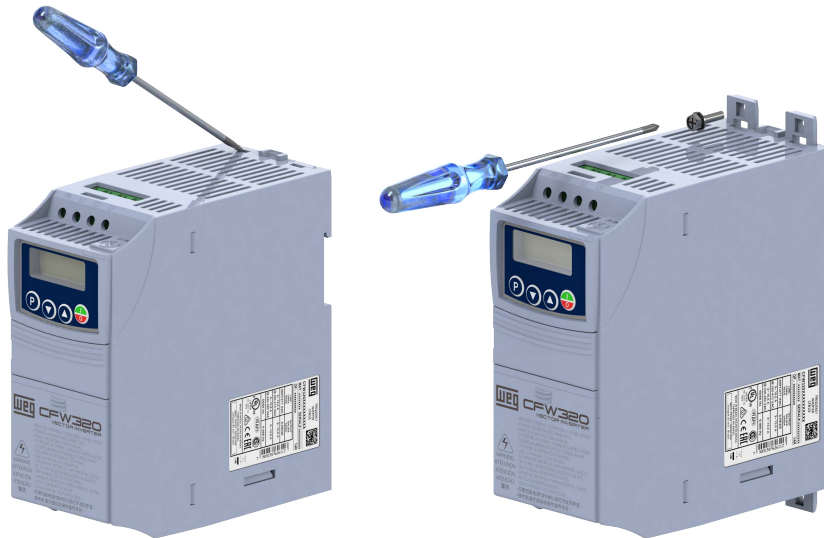

(a) Surface mounting

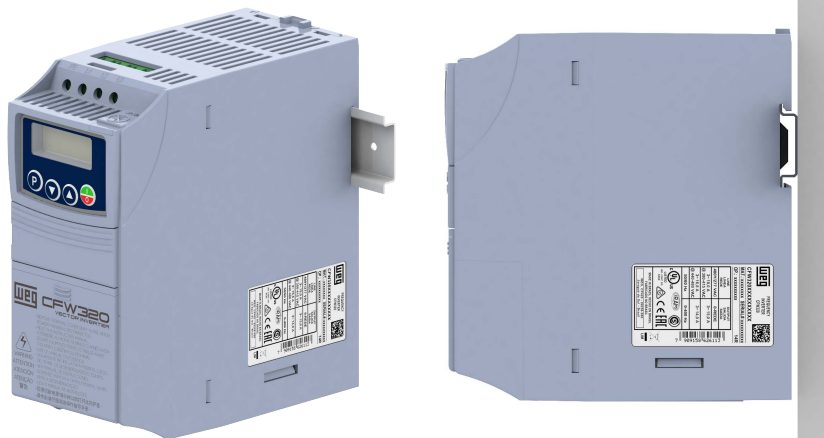

(b) DIN rail mounting

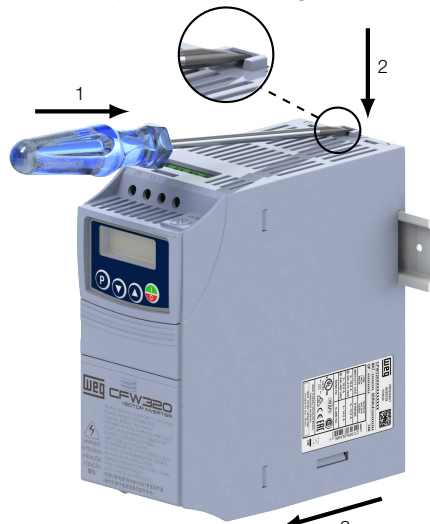

(c) Removal of CFW320 on DIN Rail

Remove the CFW320 from the DIN rail by following the steps:

- (1) Using a suitable size screwdriver (longer than the depth of the product), position it on the product at the indicated location.
- (2) Press the product release latch down.
- (3) Remove the CFW320 from the DIN rail by first removing the bottom of the product.

**Note:** no tool is required for fixing the CFW320 to the DIN rail.



**(d) Minimum ventilation free spaces**

Frame size	A	B	C
	mm (in)	mm (in)	mm (in)
A	15 (0.59)	40 (1.57)	30 (1.18)
B	35 (1.38)	50 (1.97)	40 (1.57)
C	40 (1.57)	50 (1.97)	50 (1.97)

Dimension tolerance:  $\pm 1.0$  mm ( $\pm 0.039$  in)

**Figure A7:** (a) to (d) Mechanical installation data (surface mounting and minimum ventilation free spaces)

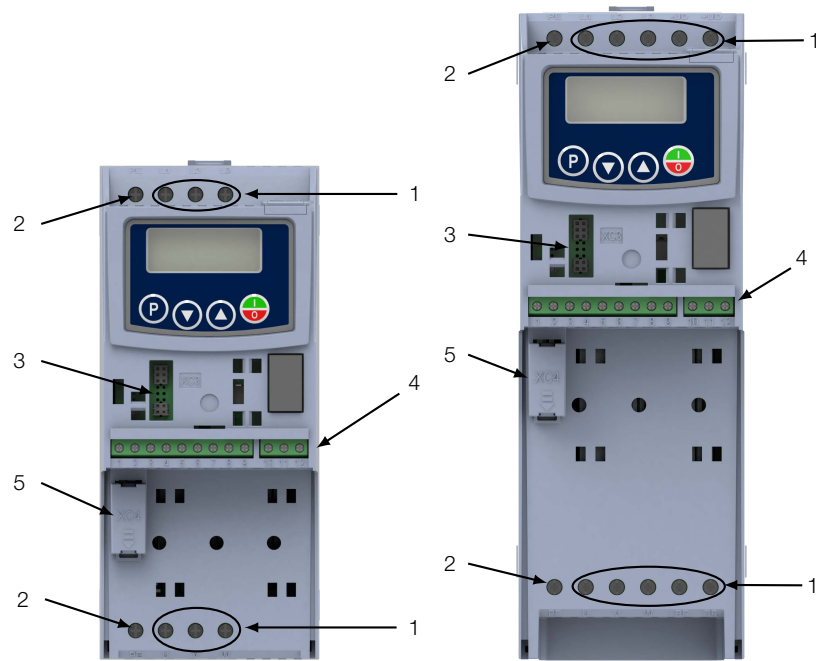

- 1 - Power terminals
- 2 - Grounding points
- 3 - Connector of the communication accessory
- 4 - Control terminals
- 5 - Connector of the I/O expansion accessory

Frame size	Recommended Torque			
	Grounding Points		Power Terminals	
	N.m	Lbf.in	N.m	Lbf.in
A	0.8	7.2	0.8	7.2
B				
C				

**Figure A8:** Power terminals, grounding and recommended tightening torque

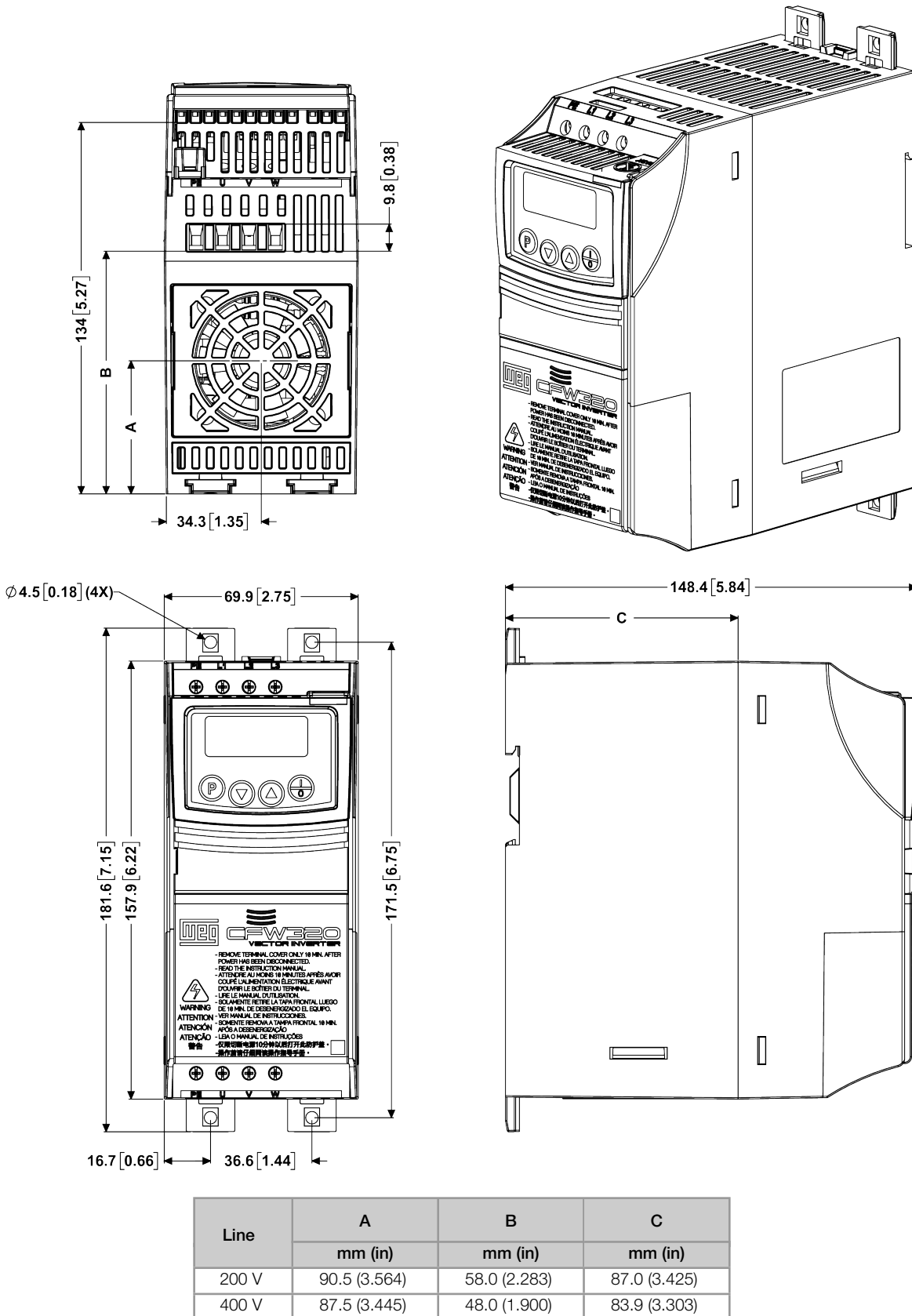

Figure A9: Inverter dimensions in mm [in] - frame size A



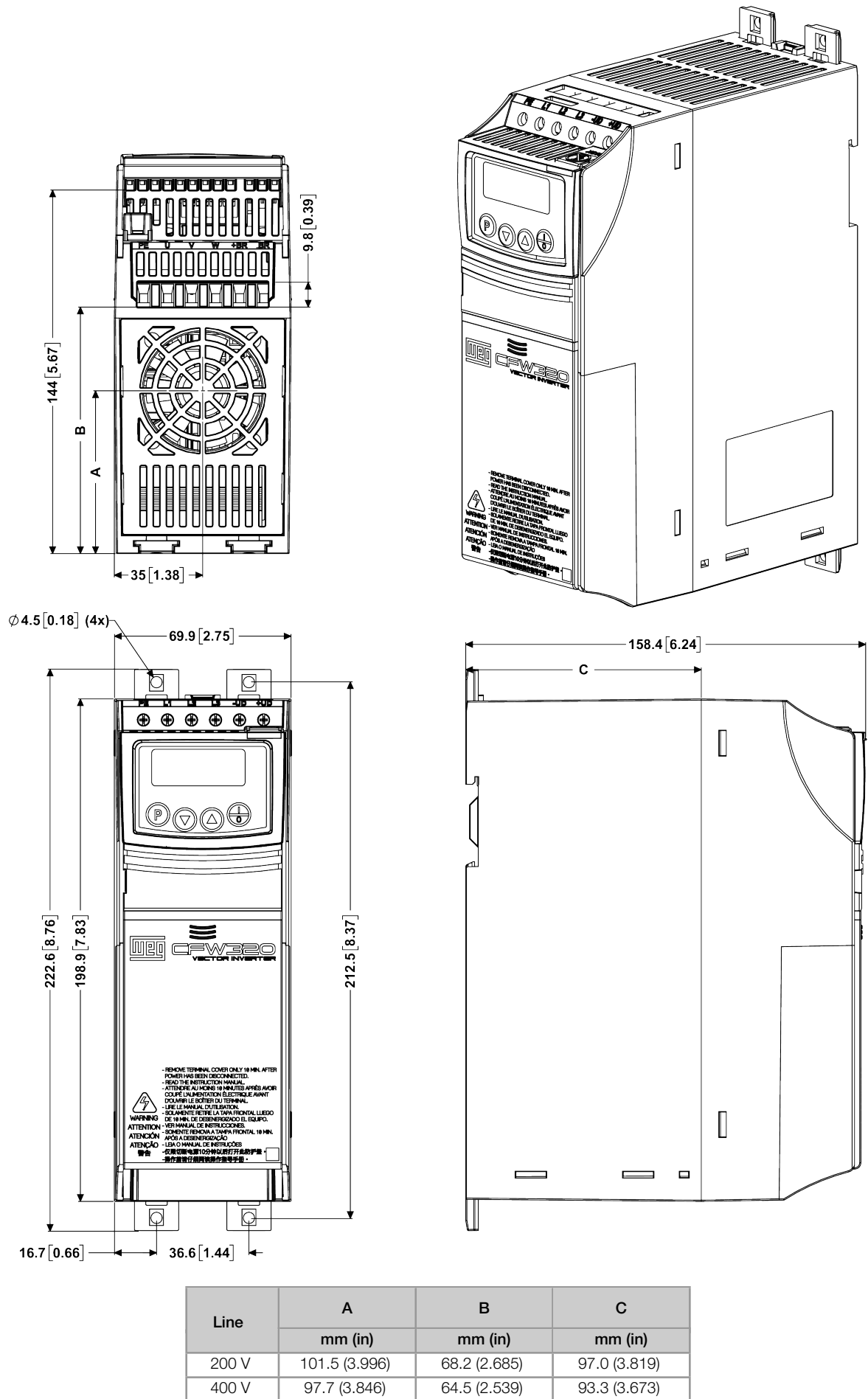

Figure A10: Inverter dimensions in mm [in] - frame size B

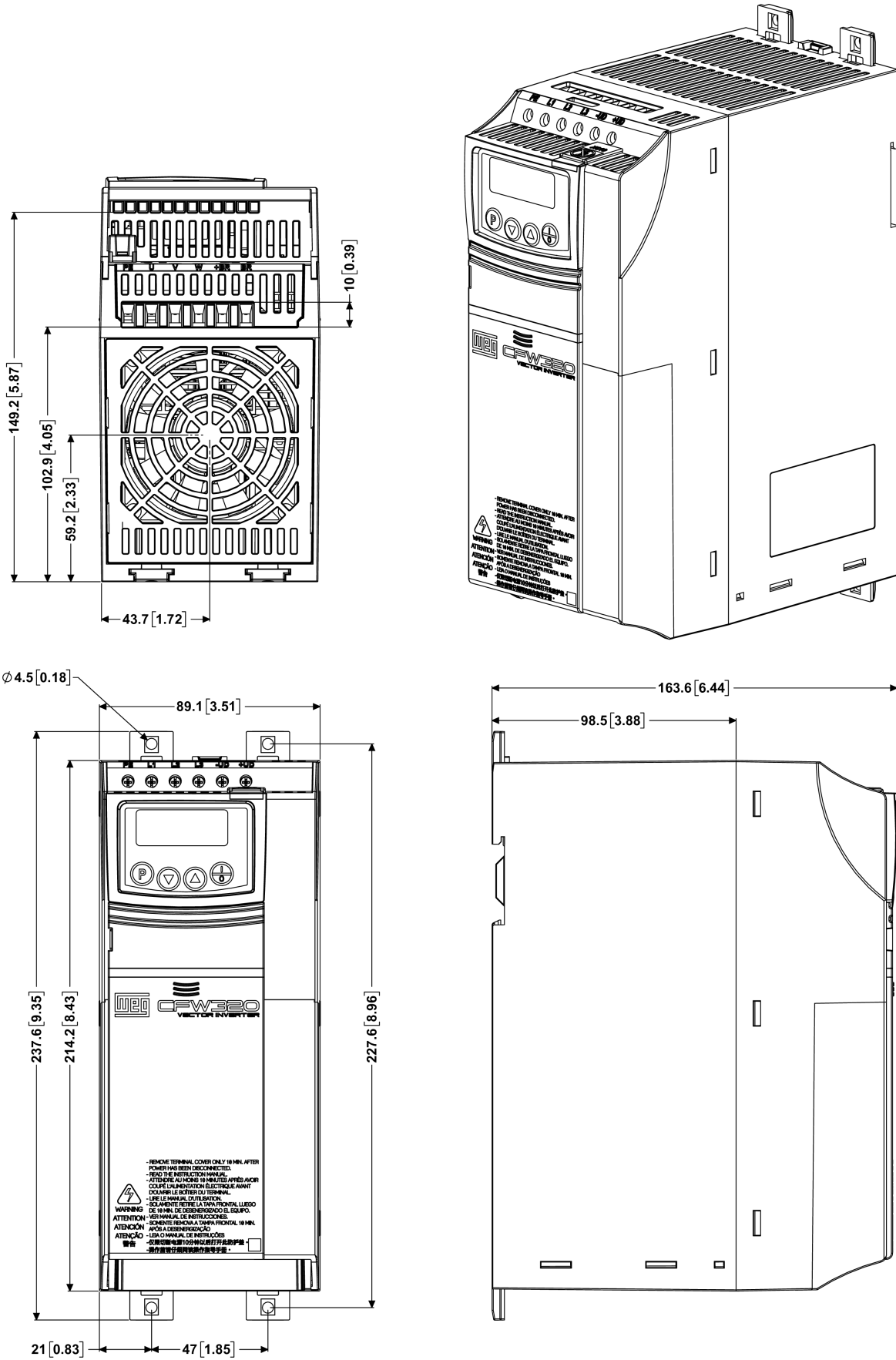

Figure A11: Inverter dimensions in mm [in] - frame size C

## APPENDIX B - TECHNICAL SPECIFICATIONS

**Table B1:** (a) and (b) List of models of CFW320 series, main electrical specifications  
(a) 200 V Line

Inverter	Number of Input Phases	Power Supply Rated Voltage	Frame size	Output Rated Current [Arms]	Maximum Motor [HP/kW]	Power Wire Size mm <sup>2</sup> (AWG)	Grounding Wire Size mm <sup>2</sup> (AWG)	Dynamic Braking		
								Maximum Current (Imax) [A]	Minimum Recommended Resistor [Ohm]	Braking rms Current [Arms]
CFW320A01P6S1NB20	1	110...127 Vac	A	1.6	0.25/0.18	1.5 (16)	2.5 (14)			
CFW320A02P6S1NB20	1	110...127 Vac	A	2.6	0.5/0.37	2.5 (14)	2.5 (14)			
CFW320A04P2S1NB20	1	110...127 Vac	A	4.2	1/0.75	2.5 (14)	4.0 (12)			
CFW320A06P0S1NB20	1	110...127 Vac	A	6.0	1.5/1.32	4.0 (12)	4.0 (12)			
CFW320A01P6S2NB20	1	200...240 Vac	A	1.6	0.25/0.18	1.5 (16)	2.5 (14)			
CFW320A02P6S2NB20	1	200...240 Vac	A	2.6	0.5/0.37	1.5 (16)	2.5 (14)			
CFW320A04P2S2NB20	1	200...240 Vac	A	4.2	1/0.75	1.5 (16)	2.5 (14)			
CFW320A06P0S2NB20	1	200...240 Vac	A	6.0	1.5/1.32	2.5 (14)	4.0 (12)			
CFW320A01P6T2NB20	1	200...240 Vac	A	1.6	0.25/0.18	1.5 (16)	2.5 (14)			
CFW320A02P6T2NB20	1	200...240 Vac	A	2.6	0.5/0.37	1.5 (16)	2.5 (14)			
CFW320A04P2T2NB20	1	200...240 Vac	A	4.2	1/0.75	1.5 (16)	2.5 (14)			
CFW320A06P0T2NB20	1	200...240 Vac	A	6.0	1.5/1.32	2.5 (14)	4.0 (12)			
CFW320A07P3T2NB20	1	200...240 Vac	A	7.3	2/1.5	2.5 (14)	4.0 (12)			
CFW320A01P6D3NB20	1	280...340 Vdc	A	1.6	0.25/0.18	1.5 (16)	2.5 (14)			
CFW320A02P6D3NB20	1	280...340 Vdc	A	2.6	0.5/0.37	1.5 (16)	2.5 (14)			
CFW320A04P2D3NB20	1	280...340 Vdc	A	4.2	1/0.75	1.5 (16)	2.5 (14)			
CFW320A06P0D3NB20	1	280...340 Vdc	A	6.0	1.5/1.32	2.5 (14)	4.0 (12)			
CFW320A07P3D3NB20	1	280...340 Vdc	A	7.3	2/1.5	2.5 (14)	4.0 (12)			
CFW320B10P0S2DB20	1/3	200...240 Vac / 280...340 Vdc	B	10.0	3/2.2	4.0 (12)	4.0 (12)	11	39	10
CFW320B15P2T2DB20	3	200...240 Vac / 280...340 Vdc	B	15.2	5/3.7	4.0 (12)	4.0 (12)	11	39	10

Dynamic braking not available



(b) 400 V Line

Inverter	Number of Input Phases	Power Supply Rated Voltage (Y)	Frame size	Output Rated Current		Maximum Motor	Maximum Motor @ UL	Power Wire Size	Grounding Wire Size	Dynamic Braking				
				Range 1 (1), (2)	Range 2 (1), (2)					[Arms]	[HP/kW]	mm <sup>2</sup> (AWG)	(Imax) [A]	[Ohm]
CFW320A01P1T4NB20	3	380...480 Vac	A	1.1		0.5/0.37	0.5/0.37	1.5 (16)	2.5 (14)					
CFW320A01P8T4NB20	3	380...480 Vac	A	1.8		1/0.75	0.75/0.55	1.5 (16)	2.5 (14)					
CFW320A02P6T4NB20	3	380...480 Vac	A	2.6		1.5/1.1	1/0.75	1.5 (16)	2.5 (14)					
CFW320A03P5T4NB20	3	380...480 Vac	A	3.5		2/1.5		1.5 (16)	2.5 (14)					
CFW320A04P8T4NB20	3	380...480 Vac	A	4.8		3/2.2		1.5 (16)	2.5 (14)					
CFW320B06P5T4NB20	3	380...480 Vac / 513...650 Vdc	B	6.5	5.6	4/3	-	1.5 (16)	2.5 (14)					
CFW320B08P2T4NB20	3	380...480 Vac / 513...650 Vdc	B	8.2	7.6	5.5/4.0	5/3.7	2.5 (14)	2.5 (14)					
CFW320C10P0T4NB20	3	380...480 Vac / 513...650 Vdc	C	10.0	8.3	6/4.5	-	2.5 (14)	2.5 (14)					
CFW320C12P0T4NB20	3	380...480 Vac / 513...650 Vdc	C	12.0	11.0	7.5/5.5		4.0 (12)	4.0 (12)					
CFW320C15P0T4NB20	3	380...480 Vac / 513...650 Vdc	C	15.0	14.0	10/7.5		4.0 (10)	4.0 (10)					
CFW320B01P1T4DB20	3	380...480 Vac / 513...650 Vdc	B	1.1		0.5/0.37	0.5/0.37	1.5 (16)	2.5 (14)			180	3.1	1.5 (16)
CFW320B01P8T4DB20	3	380...480 Vac / 513...650 Vdc	B	1.8		1/0.75	0.75/0.55	1.5 (16)	2.5 (14)			180	3.1	1.5 (16)
CFW320B02P6T4DB20	3	380...480 Vac / 513...650 Vdc	B	2.6		1.5/1.1	1/0.75	1.5 (16)	2.5 (14)			180	3.1	1.5 (16)
CFW320B03P5T4DB20	3	380...480 Vac / 513...650 Vdc	B	3.5		2/1.5		1.5 (16)	2.5 (14)			180	3.1	1.5 (16)
CFW320B04P8T4DB20	3	380...480 Vac / 513...650 Vdc	B	4.8		3/2.2		1.5 (16)	2.5 (14)			82	6.9	2.5 (14)
CFW320B06P5T4DB20	3	380...480 Vac / 513...650 Vdc	B	6.5	5.6	4/3	-	1.5 (16)	2.5 (14)			68	8.3	2.5 (14)
CFW320B08P2T4DB20	3	380...480 Vac / 513...650 Vdc	B	8.2	7.6	5.5/4.0	5/3.7	2.5 (14)	2.5 (14)			68	8.3	2.5 (14)
CFW320C10P0T4DB20	3	380...480 Vac / 513...650 Vdc	C	10.0	8.3	6/4.5	-	2.5 (14)	2.5 (14)			39	14.5	4.0 (10)
CFW320C12P0T4DB20	3	380...480 Vac / 513...650 Vdc	C	12.0	11.0	7.5/5.5		4.0 (12)	4.0 (12)			39	14.5	4.0 (10)
CFW320C15P0T4DB20	3	380...480 Vac / 513...650 Vdc	C	15.0	14.0	10/7.5		4.0 (10)	4.0 (10)			39	14.5	4.0 (10)

Dynamic braking not available

Notes:

- (1) Ranges 1 and 2 only for 400 V Line.
- (2) Range 1: Grid supply voltage: 380-400-415 Vac (513-540-560 Vdc).
- (3) Range 2: Grid supply voltage: 440-460-480 Vac (594-621-650 Vdc).

**Table B2: (a) and (b) Fuses and circuit breaker specifications for inverter protection**  
**(a) AC Power Supply**

Inverter	AC Power Supply				Motor-protector Circuit Breaker									
	Fuse Maximum I <sub>st</sub> [A's]	Maximum Voltage [Vac]	Input Phases	Fuse (semiconductor type, class aR)		WEG Model		Max. Input Voltage <sup>(2)</sup>						
				Fuse Current [A]	WEG aR Fuse WEG	SCCR <sup>(1)</sup> [kA]	[A]	WEG	≤ 127 V	≤ 240 V	≤ 415 V	≤ 440 V	≤ 480 V	
CFW320A01P6S1NB20	375		-	20	FNH00-20K-A	65	10	MPW40-3-U010	65	-	-	-	-	-
CFW320A02P6S1NB20	375	127 V	1	20	FNH00-20K-A	65	16	MPW40-3-U016	65	-	-	-	-	-
CFW320A04P2S1NB20	660			35	FNH00-35K-A	65	20	MPW40-3-U020	65	-	-	-	-	-
CFW320A06P0S1NB20	660			40	FNH00-40K-A	65	32	MPW40-3-U032	65	-	-	-	-	-
CFW320A01P6S2NB20	375			20	FNH00-20K-A	65	6.3	MPW40-3-D063	-	65	-	-	-	-
CFW320A02P6S2NB20	375		1	20	FNH00-20K-A	65	10	MPW40-3-U010	-	65	-	-	-	-
CFW320A04P2S2NB20	375			20	FNH00-20K-A	65	16	MPW40-3-U016	-	65	-	-	-	-
CFW320A06P0S2NB20	660			20	FNH00-20K-A	65	16	MPW40-3-U016	-	65	-	-	-	-
CFW320A07P3S2NB20	660			25	FNH00-25K-A	65	20	MPW40-3-U020	-	65	-	-	-	-
CFW320A01P6T2NB20	500			20	FNH00-20K-A	65	2.5	MPW40-3-D025	-	65	-	-	-	-
CFW320A02P6T2NB20	500	240 V		20	FNH00-20K-A	65	6.3	MPW40-3-D063	-	65	-	-	-	-
CFW320A04P2T2NB20	500		3	20	FNH00-20K-A	65	10	MPW40-3-U010	-	65	-	-	-	-
CFW320A06P0T2NB20	500			20	FNH00-20K-A	65	10	MPW40-3-U010	-	65	-	-	-	-
CFW320A07P3T2NB20	500			20	FNH00-20K-A	65	16	MPW40-3-U016	-	65	-	-	-	-
CFW320B10P0B2DB20	300		1/3	35	FNH00-35K-A	65	25	MPW40-3-U025	-	65	-	-	-	-
CFW320B15P2T2DB20	685		3	35	FNH00-35K-A	65	25	MPW40-3-U025	-	65	-	-	-	-
CFW320A01P1T4NB20	94.5			20	FNH000-20K-A	65	1.6	MPW40-3-D016	-	-	-	-	65	-
CFW320A01P8T4NB20	94.5			20	FNH000-20K-A	65	2.5	MPW40-3-D025	-	-	-	-	65	-
CFW320A02P6T4NB20	167			20	FNH000-20K-A	65	4	MPW40-3-U004	-	-	-	-	65	-
CFW320A03P5T4NB20	167			20	FNH000-20K-A	65	6.3	MPW40-3-D063	-	-	-	-	65	-
CFW320A04P8T4NB20	252			20	FNH000-20K-A	65	10	MPW40-3-U010	-	-	65	50 <sup>(a)</sup>	42 <sup>(a)</sup>	42 <sup>(a)</sup>
CFW320B06P5T4NB20	416			20	FNH000-20K-A	65	10	MPW40-3-U010	-	-	65	50 <sup>(a)</sup>	42 <sup>(a)</sup>	42 <sup>(a)</sup>
CFW320B08P2T4NB20	416			25	FNH000-25K-A	65	16	MPW40-3-U016	-	-	-	50 <sup>(a)</sup>	10 <sup>(a)</sup>	10 <sup>(a)</sup>
CFW320C10P0T4NB20	510			25	FNH000-25K-A	65	16	MPW40-3-U016	-	-	-	50 <sup>(a)</sup>	10 <sup>(a)</sup>	10 <sup>(a)</sup>
CFW320C12P0T4NB20	510			35	FNH000-35K-A	65	20	MPW40-3-U020	-	-	-	50 <sup>(a)</sup>	10 <sup>(a)</sup>	10 <sup>(a)</sup>
CFW320C15P0T4NB20	510	480Y/277 V <sup>(a)</sup>	3	35	FNH000-35K-A	65	25	MPW40-3-U025	-	-	-	50 <sup>(a)</sup>	10 <sup>(a)</sup>	10 <sup>(a)</sup>
CFW320B01P1T4DB20	94.5			20	FNH000-20K-A	65	1.6	MPW40-3-D016	-	-	-	-	65	-
CFW320B01P8T4DB20	94.5			20	FNH000-20K-A	65	2.5	MPW40-3-D025	-	-	-	-	65	-
CFW320B02P6T4DB20	167			20	FNH000-20K-A	65	4	MPW40-3-U004	-	-	-	-	65	-
CFW320B03P5T4DB20	167			20	FNH000-20K-A	65	6.3	MPW40-3-D063	-	-	-	-	65	-
CFW320B04P8T4DB20	252			20	FNH000-20K-A	65	10	MPW40-3-U010	-	-	-	65	50 <sup>(a)</sup>	42 <sup>(a)</sup>
CFW320B06P5T4DB20	416			20	FNH000-20K-A	65	10	MPW40-3-U010	-	-	-	65	50 <sup>(a)</sup>	42 <sup>(a)</sup>
CFW320B08P2T4DB20	416			25	FNH000-25K-A	65	16	MPW40-3-U016	-	-	-	65	50 <sup>(a)</sup>	42 <sup>(a)</sup>
CFW320C10P0T4DB20	510			25	FNH000-25K-A	65	16	MPW40-3-U016	-	-	-	65	50 <sup>(a)</sup>	42 <sup>(a)</sup>
CFW320C12P0T4DB20	510			35	FNH000-35K-A	65	20	MPW40-3-U020	-	-	-	65	50 <sup>(a)</sup>	42 <sup>(a)</sup>
CFW320C15P0T4DB20	510			35	FNH000-35K-A	65	25	MPW40-3-U025	-	-	-	65	50 <sup>(a)</sup>	42 <sup>(a)</sup>

**(b) DC Power Supply**

Inverter	DC Power Supply					
	Fuse Maximum I <sup>2</sup> t	Maximum Voltage	Fuse (semiconductor type, class aR)			
			Fuse Current	Quantity (in series) <sup>(4)</sup>	WEG aR Fuse	SCCR <sup>(1)</sup>
[A <sup>2</sup> s]	[Vdc]	[A]	-	WEG	[kA]	
CFW320A01P6D3NB20	-	340 V	20	1	FNH00-20K-A	65
CFW320A02P6D3NB20	-		20	1	FNH00-20K-A	65
CFW320A04P2D3NB20	-		20	1	FNH00-20K-A	65
CFW320A06P0D3NB20	-		20	1	FNH00-20K-A	65
CFW320A07P3D3NB20	-		20	1	FNH00-20K-A	65
CFW320B10P0B2DB20	300		35	1	FNH00-35K-A	65
CFW320B15P2T2DB20	685		35	1	FNH00-35K-A	65
CFW320B06P5T4NB20	416	650 V <sup>(4)</sup>	20	2	FNH000-20K-A	65
CFW320B08P2T4NB20	416		25	2	FNH000-25K-A	65
CFW320C10P0T4NB20	510		25	2	FNH000-25K-A	65
CFW320C12P0T4NB20	510		35	2	FNH000-35K-A	65
CFW320C15P0T4NB20	510		35	2	FNH000-35K-A	65
CFW320B01P1T4DB20	94.5		20	2	FNH000-20K-A	65
CFW320B01P8T4DB20	94.5		20	2	FNH000-20K-A	65
CFW320B02P6T4DB20	167		20	2	FNH000-20K-A	65
CFW320B03P5T4DB20	167		20	2	FNH000-20K-A	65
CFW320B04P8T4DB20	252		20	2	FNH000-20K-A	65
CFW320B06P5T4DB20	416		20	2	FNH000-20K-A	65
CFW320B08P2T4DB20	416		25	2	FNH000-25K-A	65
CFW320C10P0T4DB20	510		25	2	FNH000-25K-A	65
CFW320C12P0T4DB20	510		35	2	FNH000-35K-A	65
CFW320C15P0T4DB20	510		35	2	FNH000-35K-A	65

**Notes:**

**(1)** A minimum line impedance might be required to avoid inverter damages and assure its expected useful life. Refer to [Item 3.2.3.2 Power Supply Reactance on page 17](#).

**(2)** CFW320 400 V Line inverter models (with rated voltage of 380 Vac...480 Vac) are specified to be used only on Wye connected electrical distribution systems. These inverters, when protected by MPW Motor Protector Circuit Breaker, may have different SCCR values according to the grid voltage (380 V, 400 V, 415 V, 440 V, 460 V or 480 V).

Please, see "Max. Input Voltage" column for the right maximum voltage value and its respective SCCR. For further information about MPW Motor Protector ratings, see the documentation available at [www.weg.net](http://www.weg.net).

**(3)** For these models, CLT32 accessory is required for 65 kA.

**(4)** For models of 400 V Line with DC power supply (513 Vdc...650 Vdc), use two fuses connected in series per each pole.

**Table B3: (a) and (b) Fuses and circuit breakers specifications for protection according to UL standard  
(a) AC Power Supply**

Inverter	Frame size	Maximum Voltage [Vac]	Input Phases	Fuse (UL Class J, 600 V)			WEG Model (4)(6)			UL Type E Line Side Terminal (6)	Trip Signaling Block (6)	Current Limiter (3)	SCCR (1)		Cabinet Minimum Dimensions (H x W x D) [mm (in)]	
				Fuse Current [A]	SCCR (1)		[A]	WEG	Standard Fault [kA]				High Fault [kA]	Standard Fault [kA]		High Fault [kA]
					[kA]	[kA]										
CFW320A01P6S1NB20	A	127 V	1	-	-	-	-	-	-	-	-	-	5	65	235 x 105 x 220 (9.3 x 4.2 x 8.7)	
CFW320A02P6S1NB20																
CFW320A04P2S1NB20																
CFW320A06P0S1NB20																
CFW320A01P6S2NB20																
CFW320A02P6S2NB20																
CFW320A04P2S2NB20																
CFW320A06P0S2NB20																
CFW320A07P3S2NB20																
CFW320A01P6T2NB20																
CFW320A02P6T2NB20	B	240 V	3	-	-	-	-	-	-	-	-	-	5	65	298 x 105 x 238 (11.8 x 4.2 x 9.4)	
CFW320A04P2T2NB20																
CFW320A06P0T2NB20																
CFW320A07P3T2NB20																
CFW320B01P0B2DB20																
CFW320B15P2T2DB20																
CFW320A01P1T4NB20																
CFW320A01P8T4NB20																
CFW320A02P6T4NB20																
CFW320A03P5T4NB20																
CFW320A04P8T4NB20	B	480Y/277 V (2)	3	-	-	-	-	-	-	-	-	-	5	65	320 x 135 x 245 (12.6 x 5.4 x 9.7)	
CFW320B06P5T4NB20																
CFW320C10P0T4NB20																
CFW320C12P0T4NB20																
CFW320C15P0T4NB20																
CFW320B01P1T4DB20																
CFW320B01P8T4DB20																
CFW320B02P6T4DB20																
CFW320B03P5T4DB20																
CFW320B04P8T4DB20																
CFW320B06P5T4DB20	C	480Y/277 V (2)	3	-	-	-	-	-	-	-	-	-	5	65	320 x 135 x 245 (12.6 x 5.4 x 9.7)	
CFW320C10P0T4DB20																
CFW320C12P0T4DB20																
CFW320C15P0T4DB20																
CFW320C10P0T4DB20																
CFW320C12P0T4DB20																
CFW320C15P0T4DB20																
CFW320C10P0T4DB20																
CFW320C12P0T4DB20																
CFW320C15P0T4DB20																

(b) DC Power Supply

Inverter	Frame size	DC Power Supply							Cabinet Minimum Dimensions (H x W x D)	
		Maximum Voltage	Fuse (UL Class J)		Fuse (Semiconductor type)		SCCR <sup>(1)</sup>			
			Fuse Current	Fuse Voltage	Fuse Current	Ferraz Shawmut (MERSEN) (700 Vdc) Fuse Model	Standard Fault	High Fault		
[Vdc]	[A]	[V]	[A]	Fuse Model	[kA]	[kA]	[mm (in)]			
CFW320A01P6D3NB20	A	340 V	6	500 Vdc	-	-	5	-	235 x 105 x 220 (9.3 x 4.2 x 8.7)	
CFW320A02P6D3NB20			10	500 Vdc	-	-	5	-		
CFW320A04P2D3NB20			10	500 Vdc	-	-	5	-		
CFW320A06P0D3NB20			15	500 Vdc	-	-	5	-		
CFW320A07P3D3NB20			15	500 Vdc	-	-	5	-		
CFW320B10P0B2DB20	B	650 V	-	-	35	A70QS35-4	5	-	298 x 105 x 238 (11.8 x 4.2 x 9.4)	
CFW320B15P2T2DB20			-	-	35	A70QS35-4	5	-		
CFW320B06P5T4NB20	B		-	-	35	A70QS35-4	5	-	298 x 105 x 238 (11.8 x 4.2 x 9.4)	
CFW320B08P2T4NB20			-	-	35	A70QS35-4	5	-		
CFW320C10P0T4NB20	C		-	-	35	A70QS35-4	5	-	320 x 135 x 245 (12.6 x 5.4 x 9.7)	
CFW320C12P0T4NB20		-	-	35	A70QS35-4	5	-			
CFW320C15P0T4NB20	B	-	-	35	A70QS35-4	5	-	298 x 105 x 238 (11.8 x 4.2 x 9.4)		
CFW320B01P1T4DB20		-	-	35	A70QS35-4	5	-			
CFW320B01P8T4DB20		-	-	35	A70QS35-4	5	-			
CFW320B02P6T4DB20		-	-	35	A70QS35-4	5	-			
CFW320B03P5T4DB20		-	-	35	A70QS35-4	5	-			
CFW320B04P8T4DB20		-	-	35	A70QS35-4	5	-			
CFW320B06P5T4DB20		-	-	35	A70QS35-4	5	-			
CFW320B08P2T4DB20		-	-	35	A70QS35-4	5	-			
CFW320C10P0T4DB20		C	-	-	35	A70QS35-4	5		-	320 x 135 x 245 (12.6 x 5.4 x 9.7)
CFW320C12P0T4DB20			-	-	35	A70QS35-4	5		-	
CFW320C15P0T4DB20	-		-	35	A70QS35-4	5	-			

Notes:

- (1) A minimum line impedance might be required to avoid inverter damages and assure its expected useful life. Refer to [Item 3.2.3.2 Power Supply Reactance on page 17](#).
- (2) CFW320 inverter models of 400 V Line (with rated voltage of 380 Vac...480 Vac) are UL listed only for use on Wye connected electrical distribution systems (380Y/220 V to 480Y/277 V systems). They are not UL listed for use on Delta/Delta systems, Delta corner ground, or high-impedance ground systems (IT system), on the voltages of 380-480 V.
- (3) Manual Self-Protected (Type E) Combination Motor Controller, UL listed for 200 - 240 V and 480Y/277 V systems. Not UL listed for use on 480 V Delta/Delta systems, corner ground, or high-impedance ground systems (IT system).
- (4) For other ratings of MPW Motor Protector Circuit Breaker applied as a Type E Motor Controller, see the documentation available at [www.weg.net](http://www.weg.net).
- (5) Largest WEG Type E Combination Motor Controller recommended.
- (6) MPW motor protector accessories required for Type E Motor Controller.
- (7) For Standard Fault Current Level, the CLT32 accessory is not required. For High Fault Current Level, the CLT32 accessory is required for 65 kA in the models indicated by notes (7) and (8).
- (8) For these models, CLT32 accessory is required for 65 kA (without CLT32 current limiter, the SCCR maximum is 50 kA).
- (9) For this model, CLT32 accessory is required for 65 kA (without CLT32 current limiter, the SCCR maximum is 42 kA).



**Table B4:** (a) and (b) Input and output currents, overload currents, carrier frequency, surrounding air temperature and power losses specifications  
(a) 200 V Line

Inverter	Output Rated Current	Overload Currents	Rated Carrier Frequency	Nominal Inverter Surrounding Temperature	Input Rated Current	Overload Input Current	Inverter Power Losses	
				Side-by-side IP20			Surface Mounting	
				[°C / °F]			[Arms]	[W]
				(Inom) [Arms]			1 min [Arms]	(fsw) [kHz]
CFW320A01P6S1NB20	1.6	2.4	5	50/122	7.1	10.7	30	
CFW320A02P6S1NB20	2.6	3.9			11.5	17.3	45	
CFW320A04P2S1NB20	4.2	6.3			18.6	27.9	60	
CFW320A06P0S1NB20	6.0	9.0			26.5	39.8	75	
CFW320A01P6S2NB20	1.6	2.4			3.5	5.3	30	
CFW320A02P6S2NB20	2.6	3.9			5.7	8.6	35	
CFW320A04P2S2NB20	4.2	6.3			9.2	13.8	50	
CFW320A06P0S2NB20	6.0	9.0			13.2	19.8	75	
CFW320A07P3S2NB20	7.3	11.0			16.1	24.2	90	
CFW320A01P6T2NB20	1.6	2.4			1.9	2.9	30	
CFW320A02P6T2NB20	2.6	3.9			3.1	4.7	35	
CFW320A04P2T2NB20	4.2	6.3			5.0	7.5	50	
CFW320A06P0T2NB20	6.0	9.0			7.2	10.8	75	
CFW320A07P3T2NB20	7.3	11.0			8.8	13.2	90	
CFW320A01P6D3NB20	1.6	2.4			1.9	2.9	30	
CFW320A02P6D3NB20	2.6	3.9			3.1	4.7	35	
CFW320A04P2D3NB20	4.2	6.3			5.0	7.5	50	
CFW320A06P0D3NB20	6.0	9.0			7.2	10.8	75	
CFW320A07P3D3NB20	7.3	11.0			8.8	13.2	90	
CFW320B10P0B2DB20	10.0	15.0			22.0/12.0	33.0/18.0	100	
CFW320B15P2T2DB20	15.2	22.8	18.2	27.3	160			



(b) 400 V Line

Inverter	Output Rated Current		Nominal Inverter Surrounding Temperature	Input Rated Current		Overload Input Current	Inverter Power Losses			
	Range 1 (1),(2)	Range 2 (1),(3)		Range 1 (1),(2)	Range 2 (1),(3)			Range 1 (1),(2)	Range 2 (1),(3)	
	(Inom) [Arms]			[Arms]				1 min [Arms]		Surface Mounting
	[Arms]			[Arms]				[Arms]		[W]
CFW320A01P1T4NB20	1.1		Side-by-side IP20	1.3		2.0	26			
CFW320A01P8T4NB20	1.8			2.2		3.2	35			
CFW320A02P6T4NB20	2.6			3.1		4.7	42			
CFW320A03P5T4NB20	3.5			4.2		6.3	55			
CFW320A04P8T4NB20	4.8			5.8		8.6	69			
CFW320B06P5T4NB20	6.5	5.6		7.8	6.7	11.7	10.1	91		
CFW320B08P2T4NB20	8.2	7.6		9.8	9.1	14.8	13.7	111		
CFW320C10P0T4NB20	10.0	8.3		12.0	10.0	18.0	14.9	140		
CFW320C12P0T4NB20	12.0	11.0		14.4	13.2	21.6	19.8	164		
CFW320C15P0T4NB20	15.0	14.0		18.0	16.8	27.0	25.2	172		
CFW320B01P1T4DB20	1.1			1.3		2.0	26			
CFW320B01P8T4DB20	1.8			2.2		3.2	35			
CFW320B02P6T4DB20	2.6			3.1		4.7	42			
CFW320B03P5T4DB20	3.5			4.2		6.3	55			
CFW320B04P8T4DB20	4.8			5.8		8.6	69			
CFW320B06P5T4DB20	6.5	5.6		7.8	6.7	11.7	10.1	91		
CFW320B08P2T4DB20	8.2	7.6		9.8	9.1	14.8	13.7	111		
CFW320C10P0T4DB20	10.0	8.3		12.0	10.0	18.0	14.9	140		
CFW320C12P0T4DB20	12.0	11.0		14.4	13.2	21.6	19.8	164		
CFW320C15P0T4DB20	15.0	14.0		18.0	16.8	27.0	25.2	172		

Notes:

- (1) Ranges 1 and 2 only for 400 V Line.
- (2) Range 1: Grid supply voltage: 380-400-415 Vac (513-540-560 Vdc).
- (3) Range 2: Grid supply voltage: 440-460-480 Vac (694-621-650 Vdc).

**Table B5:** Conducted and radiated emission levels, and additional information

Inverter Model <sup>(1)</sup>		Carrier Frequency	Conducted Emission - Maximum Motor Cable Length		Radiated Emission <sup>(1)</sup>
			fsw [kHz]	Category C3	
200 V Line (S1, S2, B2, T2)	CFW320AXXPXS1NB20 <sup>(2)</sup>	5	20 m (787 in)	1 m (39.4 in)	C3
	CFW320AXXPXS2NB20 <sup>(2)</sup>	5	20 m (787 in)	5 m (197 in)	
	CFW320AXXPXT2NB20 <sup>(2)</sup>	5	20 m (787 in)	-	
	CFW320B10P0B2DB20 <sup>(3)</sup>	5	20 m (787 in)	5 m (197 in)	
	CFW320B15P2T2DB20 <sup>(3)</sup>	5	20 m (787 in)	-	
400 V Line (T4)	CFW320AXXPXT4NB20 <sup>(2)</sup>	5	10 m (394 in)	-	
	CFW320BXXPXT4XX20 <sup>(2), (4)</sup>	5	10 m (394 in)	10 m (394 in)	
	CFW320C10P0T4XX20 <sup>(2), (4)</sup>	5	10 m (394 in)	5 m (197 in)	
	CFW320C12P0T4XX20 <sup>(2), (4)</sup>	5	10 m (394 in)	5 m (197 in)	
	CFW320C15P0T4XX20 <sup>(2), (4)</sup>	2.5	15 m (591 in)	10 m (394 in)	

**Notes:**

**(1)** For all models, use the ferrite available with the RFI filter accessory on the motor cables (according to [Table 6.1 on page 30](#)).

**(2)** Where there is an "X", it is assumed as any corresponding value of [Table 2.2 on page 10](#).

**(3)** For frame size B models of 200 V Line, a cabinet with a minimum attenuation of 12dB must be used - see [Table 3.3 on page 23](#).

**(4)** For frame sizes B and C models of 400 V Line, use the second ferrite available with the RFI filter accessory on the power supply cables (according to [Table 6.1 on page 30](#)).

**Table B6:** (a) and (b) Specification of the output current as a function of the switching frequency for the CFW320

**(a) 200 V Line**

Inverter Model		2.5 KHz	5.0 KHz	10.0 KHz	15.0 KHz
200 V Line (S1, S2, B2, T2, D3)	CFW320A01P6...	1.6 A	1.6 A	1.6 A	1.6 A
	CFW320A02P6...	2.6 A	2.6 A	2.6 A	2.6 A
	CFW320A04P2...	4.2 A	4.2 A	4.2 A	4.2 A
	CFW320A06P0...	6.0 A	6.0 A	5.4 A	4.6 A
	CFW320A07P3...	7.3 A	7.3 A	6.6 A	5.0 A
	CFW320B10P0...	10.0 A	10.0 A	9.0 A	8.0 A
	CFW320B15P2...	15.2 A	15.2 A	11.0 A	9.0 A

**(b) 400 V Line**

Inverter Model		2.5 KHz		5.0 KHz		10.0 KHz		15.0 KHz	
		Range 1 (1), (2)	Range 2 (1), (3)	Range 1 (1), (2)	Range 2 (1), (3)	Range 1 (1), (2)	Range 2 (1), (3)	Range 1 (1), (2)	Range 2 (1), (3)
400 V Line (T4)	CFW320X01P1... (4)	1.1 A		1.1 A		1.1 A		0.9 A	
	CFW320X01P8... (4)	1.8 A		1.8 A		1.3 A		0.9 A	
	CFW320X02P6... (4)	2.6 A		2.6 A		2.5 A		1.8 A	
	CFW320X03P5... (4)	3.5 A		3.5 A		2.5 A		1.8 A	
	CFW320X04P8... (4)	4.8 A		4.8 A		3.4 A		2.4 A	
	CFW320B06P5...	6.5 A	5.6 A	6.5 A	5.6 A	4.6 A	3.9 A	3.3 A	2.8 A
	CFW320B08P2...	8.2 A	7.6 A	8.2 A	7.6 A	4.9 A	4.6 A	3.3 A	3.0 A
	CFW320C10P0...	10.0 A	8.3 A	10.0 A	8.3 A	7.0 A	5.8 A	5.0 A	4.2 A
	CFW320C12P0...	12.0 A	11.0 A	12.0 A	11.0 A	8.3 A	7.7 A	6.0 A	5.5 A
	CFW320C15P0...	15.0 A	14.0 A	12.0 A	11.0 A	8.3 A	7.7 A	6.0 A	5.5 A

**Notes:**

- (1) Ranges 1 and 2 only for **400 V Line**.
- (2) **Range 1:** Grid supply voltage: 380-400-415 Vac (513-540-560 Vdc).
- (3) **Range 2:** Grid supply voltage: 440-460-480 Vac (594-621-650 Vdc).
- (4) Where there is an "X", it is assumed as "A" or "B".

**Table B7: Line and load reactors for the CFW320**

Inverter Model	Application <sup>(3), (4)</sup>	Reactor Model <sup>(2)</sup>	Number of Phases	Rated Current (Inr) [A]	Thermal Current (Ith) [A]	Rated Inductance (Ln) [uH]	Overload Current [A]	Overload Inductance [uH]	Winding Material	Voltage Class [kV]	Temperature Class	Certifications
CFW320A01P6S1	Line	REA-CFW-07P1-S1-2-00987	1	7.1	7.8	987	10.7	494	Aluminium	1.1	F - 155°C	[-]
	Load	REA-CFW-02P0-T2-2-04228	3	2.0	2.2	4228	3.0	2114				
CFW320A02P6S1	Line	REA-CFW-11P5-S1-2-00609	1	11.5	12.7	609	17.3	305				
	Load	REA-CFW-03P2-T2-2-02643	3	3.2	3.5	2643	4.8	1322				
CFW320A04P2S1	Line	REA-CFW-18P6-S1-2-00377	1	18.6	20.5	377	27.9	189				
	Load	REA-CFW-05P1-T2-2-01658	3	5.1	5.6	1658	7.7	829				
CFW320A06P0S1	Line	REA-CFW-26P5-S1-2-00264	1	26.5	29.2	264	39.8	132				
	Load	REA-CFW-07P3-T2-2-01158	3	7.3	8.0	1158	11.0	579				
CFW320A01P6S2	Line	REA-CFW-03P5-S2-2-04185	1	3.5	3.9	4185	5.3	2093				
	Load	REA-CFW-02P0-T2-2-04228	3	2.0	2.2	4228	3.0	2114				
CFW320A02P6S2	Line	REA-CFW-05P7-S2-2-02570	1	5.7	6.3	2570	8.6	1285				
	Load	REA-CFW-03P2-T2-2-02643	3	3.2	3.5	2643	4.8	1322				
CFW320A04P2S2	Line	REA-CFW-09P2-S2-2-01592	1	9.2	10.1	1592	13.8	796				
	Load	REA-CFW-05P1-T2-2-01658	3	5.1	5.6	1658	7.7	829				
CFW320A06P0S2	Line	REA-CFW-13P2-S2-2-01110	1	13.2	14.5	1110	19.8	555				
	Load	REA-CFW-07P3-T2-2-01158	3	7.3	8.0	1158	11.0	579				
CFW320A07P3S2	Line	REA-CFW-16P1-S2-2-00910	1	16.1	17.7	910	24.2	455				
	Load	REA-CFW-08P9-T2-2-00950	3	8.9	9.8	950	13.4	475				
CFW320B10P0B2	Line	REA-CFW-22P0-S2-2-00666	1	22.0	24.2	666	33.0	333				
	Line and/or Load	REA-CFW-12P2-T2-2-00693	3	12.2	13.4	693	18.3	347				
CFW320A01P6T2		REA-CFW-02P0-T2-2-04228		2.0	2.2	4228	3.0	2114				
CFW320A02P6T2		REA-CFW-03P2-T2-2-02643		3.2	3.5	2643	4.8	1322				
CFW320A04P2T2		REA-CFW-05P1-T2-2-01658	3	5.1	5.6	1658	7.7	829				
CFW320A06P0T2		REA-CFW-07P3-T2-2-01158		7.3	8.0	1158	11.0	579				
CFW320A07P3T2		REA-CFW-08P9-T2-2-00950		8.9	9.8	950	13.4	475				
CFW320B15P2T2		REA-CFW-18P5-T2-2-00457		18.5	20.4	457	27.8	229				
CFW320X01P1T4 <sup>(1)</sup>		REA-CFW-01P3-T4-2-11313		1.3	1.4	11313	2.0	5657				
CFW320X01P8T4 <sup>(1)</sup>		REA-CFW-02P2-T4-2-06685		2.2	2.4	6685	3.3	3343				
CFW320X02P6T4 <sup>(1)</sup>		REA-CFW-03P2-T4-2-04596		3.2	3.5	4596	4.8	2298				
CFW320X03P5T4 <sup>(1)</sup>		REA-CFW-04P3-T4-2-03420		4.3	4.7	3420	6.5	1710				
CFW320X04P8T4 <sup>(1)</sup>		REA-CFW-05P9-T4-2-02493	3	5.9	6.5	2493	8.9	1247				
CFW320B06P5T4	Line and/or Load	REA-CFW-07P9-T4-2-01862		7.9	8.7	1862	11.9	931				
CFW320B08P2T4		REA-CFW-10P0-T4-2-01471		10.0	11.0	1471	15.0	736				
CFW320C10P0T4		REA-CFW-12P2-T4-2-01205		12.2	13.4	1205	18.3	603				
CFW320C12P0T4		REA-CFW-14P6-T4-2-01007		14.6	16.1	1007	21.9	504				
CFW320C15P0T4		REA-CFW-18P3-T4-2-00804		18.3	20.1	804	27.5	402				

**Notes:**

(1) Where there is an "X", it is assumed as "A" or "B".

(2) Voltage drop of 2 % and frequency of 50 Hz.

(3) Evaluate the recommended reactor according to [Item 3.2.3.2 Power Supply Reactance on page 17](#).

(4) Load Reactors are recommended for motor cable length >100 m. However, several other issues such as additional current through the motor cables or filter capacitances, voltage drop on motor cables and filter, bearings lifetime, radio-frequency emissions, etc, may influence the Reactor dimensioning. A complete analysis of the impact of these issues must be additionally carried out and may impact the dimensioning of the inverter, motor, motor filter, among others. For further information, contact WEG.



WEG Drives & Controls - Automation LTDA.  
Jaraguá do Sul - SC - Brazil  
Phone 55 (47) 3276-4000 - Fax 55 (47) 3276-4020  
São Paulo - SP - Brazil  
Phone 55 (11) 5053-2300 - Fax 55 (11) 5052-4212  
[automacao@weg.net](mailto:automacao@weg.net)  
[www.weg.net](http://www.weg.net)