

TOSVERT VF-AS1 VF-PS1

Conduit Box Kit Option

Installation Manual

NOTICE

This instruction manual is for the installation of conduit box kits which are used for VF-AS1 and VF-PS1 inverters. Before installing, please read this manual carefully and be sure to understand its contents.

contents

1. Safety precautions.....	1
2. DC voltage test.....	1
3. Suitable inverters.....	2
4. Outline dimension with conduit box kit.....	3
5. Components.....	4
6. Installation dimensions.....	4
7. Installation procedure.....	6
① Installation procedure for group I.....	6
② Installation procedure for group II.....	6
③ Installation procedure for group III.....	8
8. Product support.....	11

Safety precautions

Warning

- Read and understand the instruction manual entirely before installing or operating the VF-AS1 or VF-PS1 inverters. Electrical construction work must be done by a qualified expert.
- Do not short across terminal PA/+ and PC/- or across the DC bus capacitors.
- Do not touch unshielded components or terminals because the unit contains many high voltage parts.
- Ground must be connected securely.
- Before installing conduit box kit to an inverter, be certain to follow the items below.
 - ① Turn off all power, including external control power.
 - ② Place a “**DO NOT TURN ON**” label on every power switch.
 - ③ Lock all power switches in their open positions.
 - ④ Wait at least 15 minutes and make sure that the charge lamp is no longer lit.
 - ⑤ Use a tester to make sure that the voltage to the DC main circuits (between PA/+ and PC/-) is 45 V or less. Refer to “DC voltage test procedure” below for details.
- Close all covers before turning on power or starting an inverter.

*** Failure to follow these instructions will result in death or serious injury.**

DC voltage test

Please use a tester with a DC voltage range of 800 VDC or more to measure DC voltage.

Test procedure:

1. Turn off the inverter's power supply.
2. Wait at least 15 minutes and make sure that the charge lamp is no longer lit.
3. Measure the voltage of DC bus between the PA/+ and the PC/- terminals to verify the voltage is less than 45 Vdc.
4. If the DC bus capacitors do not discharge completely, contact your local sales agency. Do not operate it or attempt to replace component.

Suitable Inverters

Conduit kit	VF-AS1 (rate: kW)				VF-PS1 (rate: kW)			
	240V	480V	600V	690V	240V	480V	600V	690V
NEM1101Z	0.4-1.5	0.75-2.2			0.4-1.5	0.75-2.2		
NEM1102Z	2.2 3.7	3.7			2.2 3.7	3.7		
NEM1103Z	5.5	5.5 7.5			5.5	5.5 7.5		
NEM1104Z	7.5	11	1.5-7.5		7.5	11	1.5-7.5	
NEM1105Z	11 15	15 18.5			11 15	15 18.5		
NEM1106Z	18.5 22	22		2.2-30	18.5 22	22		3.0-30
NEM1107Z		30 37				30 37		
NEM1117Z	30-45				30-45			
NEM1108Z		45-75		37-90		45-75		37-90
NEM1109Z	55	90			55 75	90 110		
NEM1110Z	75	110			90	132		
NEM1111Z		132		110-160		160		110-200
NEM1112Z		160				220		
NEM1113Z NEM1114Z		200-280		200-315		250-315		250-400
NEM1115Z		355 400				400 500		
NEM1116Z		500		400-630		630		500 630

Note: The different point between NEM1114Z and NEM1113Z is that there is a mounted braking unit with NEM1114Z. Contact your local sales agency for advice when you select a NEM1113Z or a NEM1114Z conduit box kit.

Outline dimension with conduit box kit

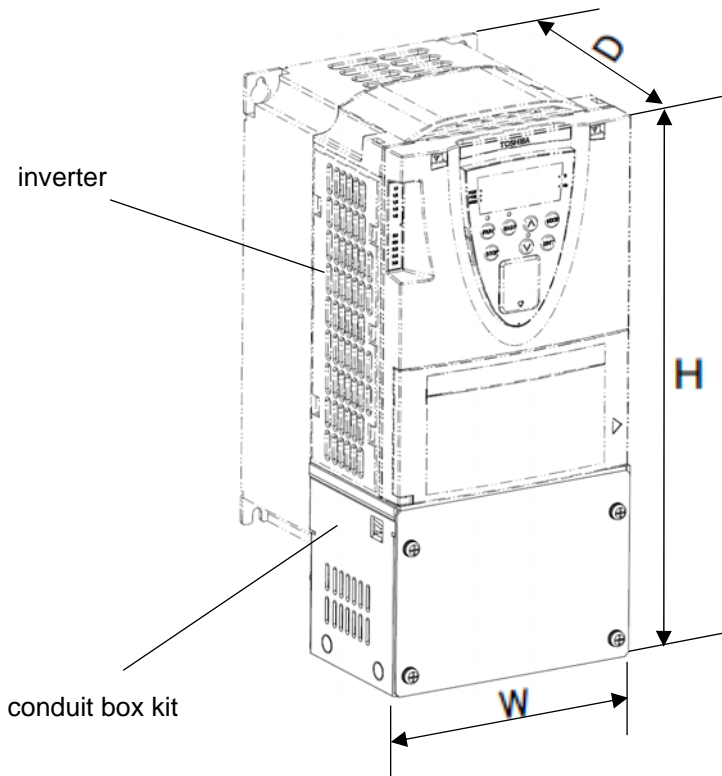

Figure 1

Conduit kit	Dimensions (mm)		
	Width (W)	Height (H)	Depth (D)
NEM1101Z	131	336	152
NEM1102Z	158	373	164
NEM1103Z	177	416	164
NEM1104Z	212	433	191
NEM1105Z	232	609	191
NEM1106Z	240	495	212
NEM1107Z	240	625	242
NEM1117Z	320	728	242
NEM1108Z	320	793	290
NEM1109Z	325	915	375
NEM1110Z	365	1094	375
NEM1111Z	345	1280	377
NEM1112Z	445	1340	377
NEM1113Z	600	1340	377
NEM1114Z	670	1340	377
NEM1115Z	895	1640	456
NEM1116Z	1125	1640	481

Components

Part name	NEM1101Z	NEM1102Z	NEM1103Z	NEM1104Z	NEM1105Z	NEM1106Z	NEM1107Z	NEM1108Z	NEM1109Z	NEM1110Z	NEM1111Z	NEM1112Z	NEM1113Z	NEM1114Z	NEM1115Z	NEM1116Z	NEM1117Z
Conduit box	1	1	1	1	1	1	1	1	1	1	1	1	1	1	1	1	1
Box cover	1	1	1	1	1	1	1	1	1	1	1	1	1	1	1	1	1
Support bar						1	1	1									1
Support frame									1	1	1	1	1	1	1	1	
EMC plate1									1	1	1	1	1	1	1	1	
EMC plate2									1								
Conduit plate									1	1	1	1	1	1	1	1	
Hardware clip set									2	2	2	2	2	2	2	2	
M4X8 screws	4	4	4	4	4	6	4	6									6
M5X12 screws	2	2	2	2	2	2	2	2									2
8-32 screws						4	4	4									4
M4X10 screws									15	13	8	15	15	15	15	15	
M6X16 screws									6	6	10	10	10	10	10	10	

Note: The hardware clip set includes a hardware clip, a M5 nut and a conical washer.

Installation dimensions

For NEM1109Z or those bigger sizes, a support frame is installed between the conduit box and the board where the inverter is fixed on. The installation dimensions are shown on below table. Please refer to figure 2 for NEM1109Z to NEM1115Z and figure 3 for NEM1116Z.

Conduit kit	installation dimensions (mm)			
	H1	H3	G	D
NEM1109Z	95	75	250	11.5x18
NEM1110Z	250	35	298	11.5x18
NEM1111Z	240	55	285	11.5x20
NEM1112Z	250	75	350	11.5x20
NEM1113Z	250	75	540	11.5x19.5
NEM1114Z				
NEM1115Z	350	75	835	11.5x20
NEM1116Z	350	75	*note	11.5x20

* Note: see figure 3 for detail dimensions.

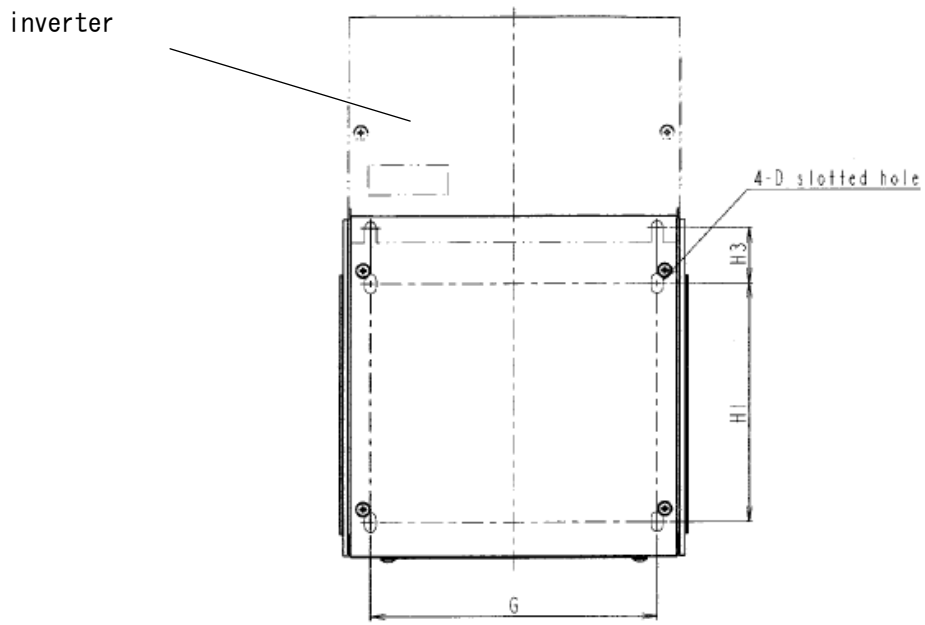

Figure 2

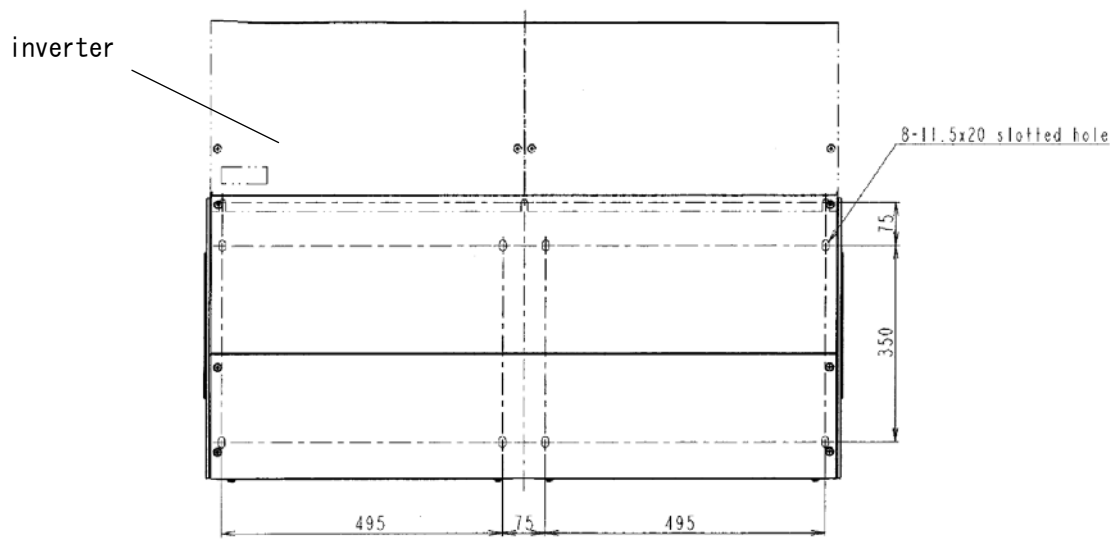

Figure 3

Installation procedure

The full range of conduit box kits is divided into three groups to better explain their installation procedures. The detail groups and recommended tightening torque values are shown below.

Table 1: Conduit groups

Group	Conduit box kit
I	NEM1101Z - NEM1105Z
II	NEM1106Z - NEM1108Z, NEM1117Z
III	NEM1109Z - NEM1116Z

Table 2: Recommended tightening torque

	N · m	lb · ins
M4	1.4	12.4
M5	3.0	26.6
M6	5.4	47.8
thread screw 8-32	1.5	13.0

1. Installation procedure for group I

Use the torque value in table 1 when you torque a screw.

Step1: Do DC voltage test for safety.

Step2: Remove the power terminal protective cover (A). Please refer to the instruction manual of inverter for details. See figure 4.

Step3: Remove the three green ground screws (B) from the inverter and install them in the three holes (C) at the base of the conduit box. See figure 5.

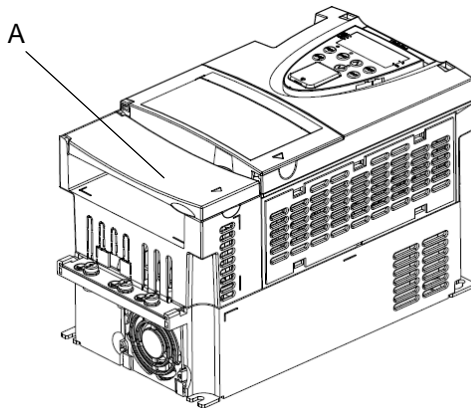

Figure 4

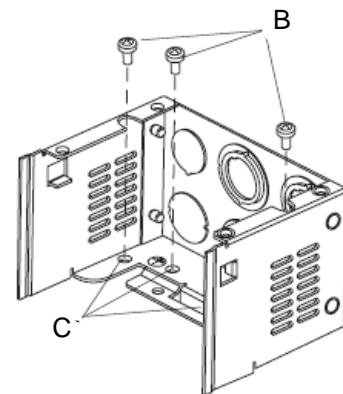

Figure 5

Step4: Attach the conduit box to the inverter and tighten it with two M5 screws (D). See figure 6.

Step5: Make all power and control connections to the inverter through the knockouts of the conduit box.

Step6: Attach the conduit cover (E) to conduit box and tighten it with four M4 screws (F). See figure 6.

Step7: Replace the inverter cover (A) removed in step2.

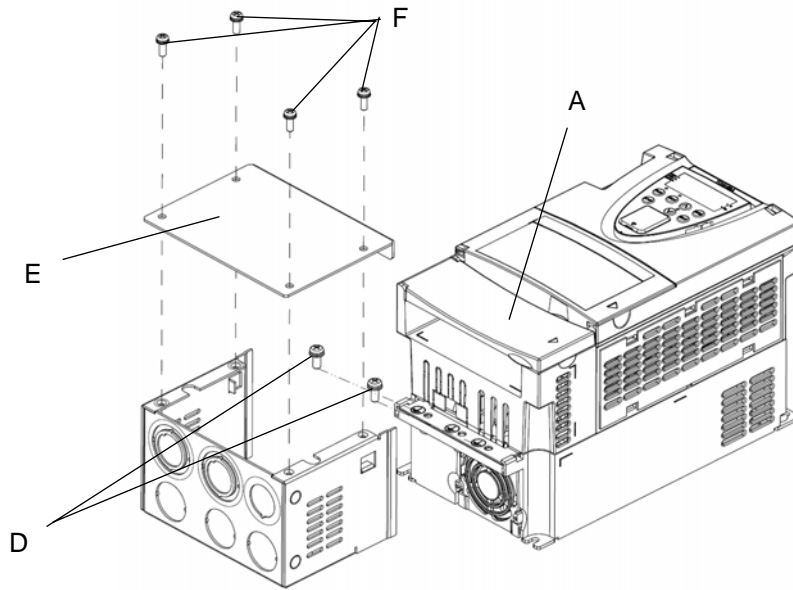

Figure 6

2. Installation procedure for group II

Use the torque value in table 1 when you torque a screw.

Step1: Do DC voltage test for safety.

Step2: Remove the front cover of the inverter (G). See figure 7.

Step3: Remove the three green ground screws (H) from the inverter and install them in the three holes (I) at the base of the conduit box. See figure 8.

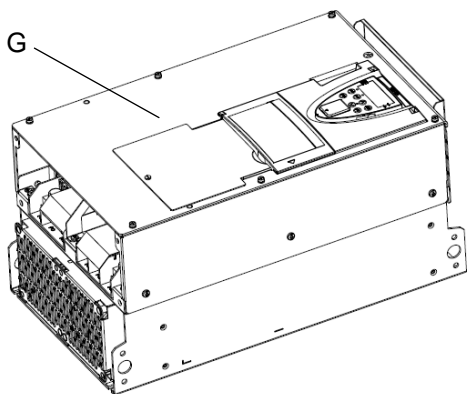

Figure 7

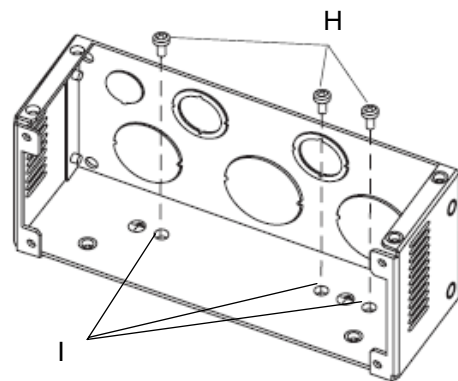

Figure 8

- Step4: Attach the conduit box support bar (J) to the inverter with two M5 screws. See figure 9.
- Step5: Attach the conduit box (K) to the conduit box support bar (J) with two M4 screws. See figure 9.
- Step6: Attach the conduit box (K) to the inverter with four self-threading screws (8-32). See figure 9.
- Step7: Make all power and control connections to the inverter through the knockouts of the conduit box.
- Step8: Attach the conduit box cover (L) to the conduit box (K) with four M4 screws. See figure 9.
- Step9: Replace the inverter cover (G) removed in step2.

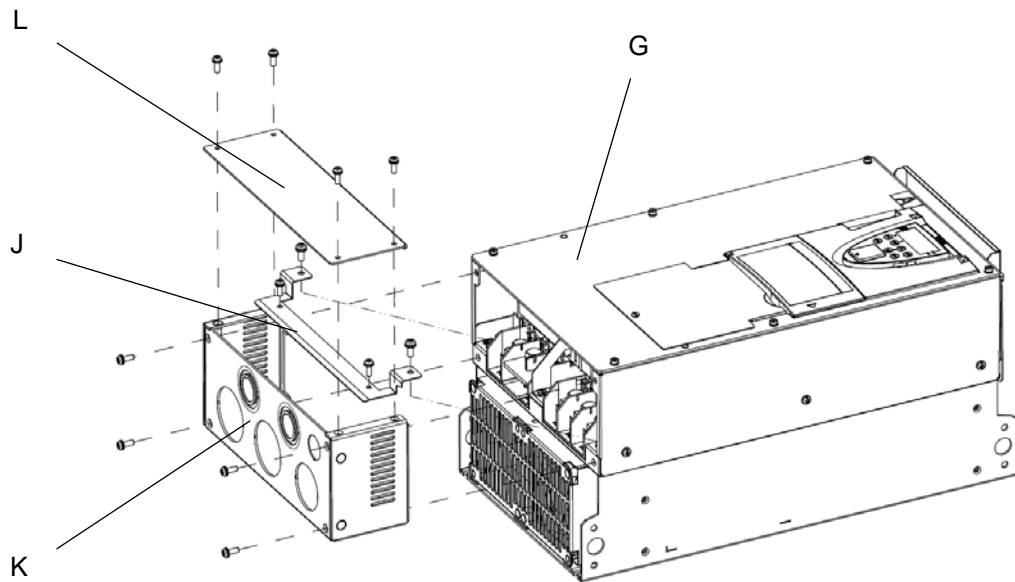

Figure 9

3. Installation procedure for group III

Use the torque value in table 1 when you torque a screw.

- Step1: Do DC voltage test for safety.
- Step2: Remove the front cover (M) from the inverter. See figure 10.
- Step3: Place the support frame (N) under the inverter and align it with inverter's chassis. See figure 11.

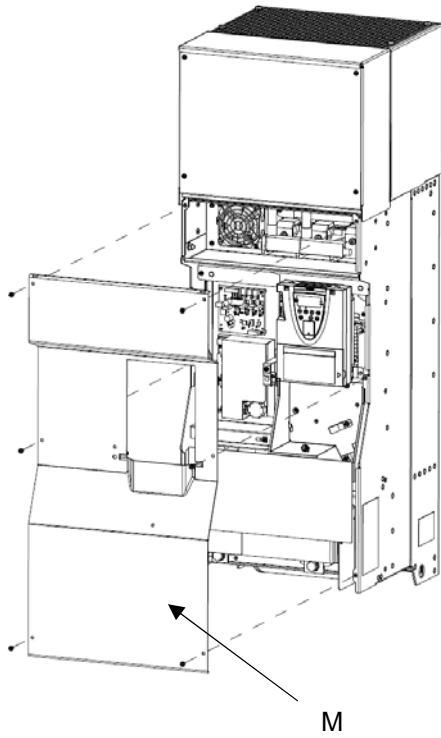

Figure 10

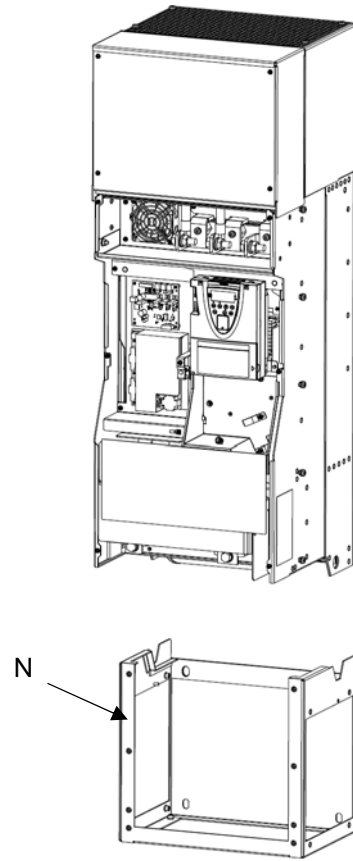

Figure 11

Step4: Attach the two hardware clip sets (O) to the two sides of support frame (N) and clip the support frame. The hardware clip set includes a hardware clip, a M5 nut and a captive conical washer. See figure 12.

Step5: Attach the conduit box (P) to the support frame with M6 screws. See figure 13.

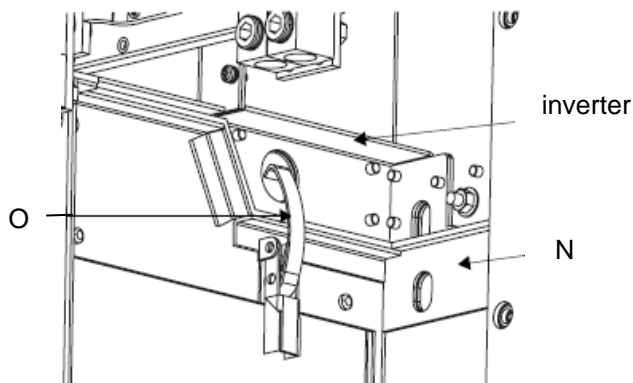

Figure 12

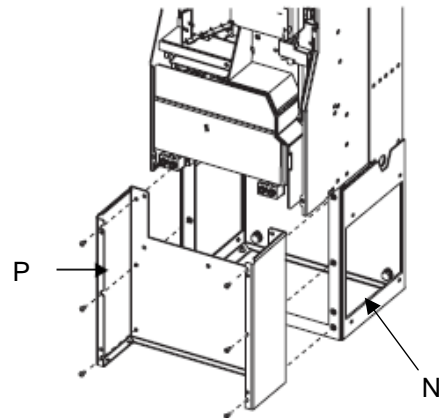

Figure 13

Step6: Mount the EMC plate1 (Q) into both the conduit box (P) and the inverter with M6 screws. See figure 14.

⚠ Caution
<ul style="list-style-type: none"> ● Be sure to install the EMC plate1 as figure 12 properly. ● Do not operate the inverter without EMC plate1 properly in place.

Failure to follow this instruction can result in injury or equipment damage.

Step7: Install the EMC plate 2 (R) as shown in figure 15. This step is only for conduit box kit NEM1109Z.

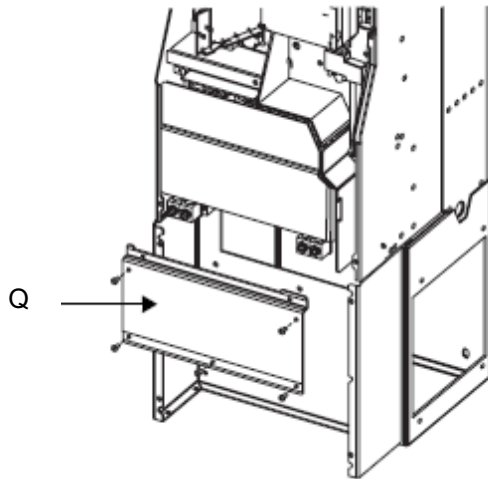

Figure 14

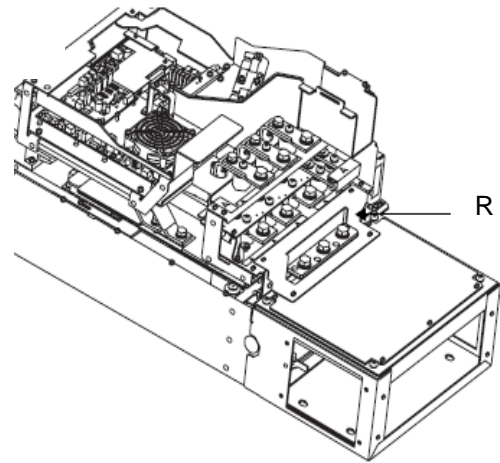

Figure 15

Step8: Install the conduit plate (S) with M4 screws. The knockouts provided are for control cables. Use either a hole saw or a punch to cut entries for power cables. See figure 16.

Step9: Make all power and control connections to the inverter.

Step10: Install the conduit box cover (T) with M4 screws. See figure 17.

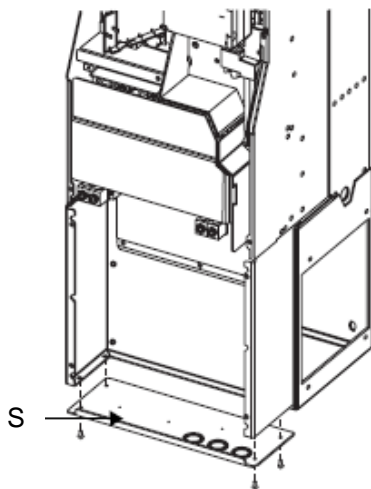

Figure 16

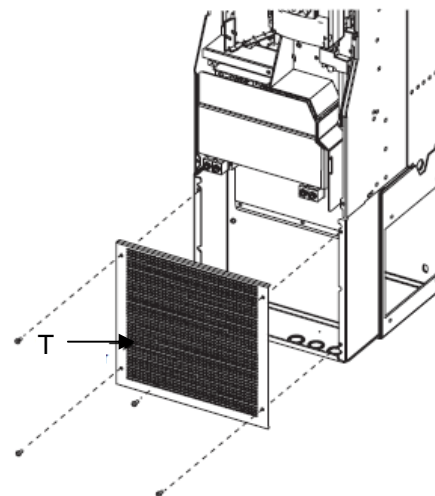

Figure 17

Step11: Replace the front cover (M) removed in step 2

Product support

If you have any question, please contact your local sales agency.