

SPECIFICATIONS - ANALOG I/O MODULES



In This Chapter:

Analog I/O Modules Overview.....	6-2
T1F-08AD-1 - 8 Channel Analog Current Input.....	6-6
T1F-08AD-2 - 8 Channel Analog Voltage Input.....	6-7
T1F-16AD-1 - 16 Channel Analog Current Input.....	6-8
T1F-16AD-2 - 16 Channel Analog Voltage Input.....	6-9
T1F-16RTD - 16 Channel RTD Input.....	6-10
T1F-16TMST - 16 Channel Thermistor Input.....	6-12
T1F-14THM - 14 Channel Thermocouple Input.....	6-14
T1F-08DA-1 - 8 Channel Analog Current Output.....	6-17
T1F-08DA-2 - 8 Channel Analog Voltage Output.....	6-18
T1F-16DA-1 - 16 Channel Analog Current Output.....	6-19
T1F-16DA-2 - 16 Channel Analog Voltage Output.....	6-20
T1F-8AD4DA-1 - 8 Channel Analog Current Input / 4 Channel Analog Current Output.....	6-21
T1F-8AD4DA-2 - 8 Channel Analog Voltage Input / 4 Channel Analog Voltage Output.....	6-23

Analog I/O Modules Overview

There are 13 analog I/O modules available. The specifications and wiring diagrams for these modules are found in this chapter. Each analog I/O module is identified as an “Input”, “Output” or “Input/Output” module using the color coding scheme shown below. A blue dot on the front panel signifies an Input module, a red dot signifies an Output module and a white dot signifies an Input/Output module.

Analog Input Modules

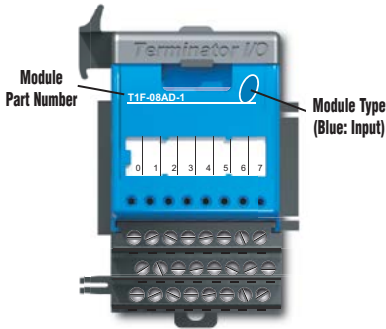

Analog Input Modules			
Part Number	Number of Channels	Description	See Page
<i>T1F-08AD-1</i>	8	Analog Current Input	6-6
<i>T1F-08AD-2</i>	8	Analog Voltage Input	6-7
<i>T1F-16AD-1</i>	16	Analog Current Input	6-8
<i>T1F-16AD-2</i>	16	Analog Voltage Input	6-9
<i>T1F-16RTD</i>	16	RTD	6-10
<i>T1F-16TMST</i>	16	Thermistor	6-12
<i>T1F-14THM</i>	14	Thermocouple	6-14

Analog Output Modules

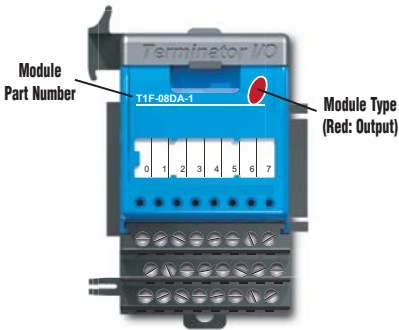

Analog Output Modules			
Part Number	Number of Channels	Description	See Page
<i>T1F-08DA-1</i>	8	Analog Current Output	6-17
<i>T1F-08DA-2</i>	8	Analog Voltage Output	6-18
<i>T1F-16DA-1</i>	16	Analog Current Output	6-19
<i>T1F-16DA-2</i>	16	Analog Voltage Output	6-20

Analog Input/Output Module

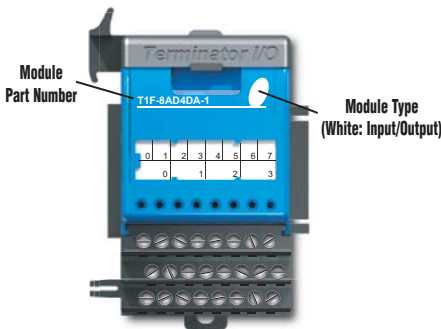

Analog Input/Output Modules			
Part Number	Number of Channels	Description	See Page
<i>T1F-8AD4DA-1</i>	8/4	Analog Current Input/Output	6-21
<i>T1F-8AD4DA-2</i>	8/4	Analog Voltage Input/Output	6-23

Analog I/O Modules Overview- continued



WARNING: The T1H Series PLC does not support any Hot-Swap features.

How to Access the Analog I/O Modules

With the Do-more PLC, the WX and WY memory addresses are assigned to exchange analog data with the analog I/O modules (WX = Analog input data, WY = Analog output data). X addresses are assigned to analog input modules and Y addresses are assigned to configure analog output modules.

The following table shows how many X, Y, WX and WY addresses are assigned to each analog I/O module type.

Analog I/O Module Addressing					
Part Number	Module ID	X	WX	Y	WY
T1F-08AD-1	0x2532	8*	8	-	-
T1F-08AD-2	0x2532	8*	8	-	-
T1F-16AD-1	0x2533	16*	16	-	-
T1F-16AD-2	0x2533	16*	16	-	-
T1F-08DA-1	0x2628	-	-	8	8
T1F-08DA-2	0x2628	-	-	8	8
T1F-16DA-1	0x262C	-	-	8	16
T1F-16DA-2	0x262C	-	-	8	16
T1F-8AD4DA-1	0x2736	8*	8	8	4
T1F-8AD4DA-2	0x2736	8*	8	8	4
T1F-16RTD	0x2573	16**	16	-	-
T1F-16TMST	0x2573	16**	16	-	-
T1F-14THM (see Note 1)	0x2573	16**	16	-	-

* X addresses assigned to this module are not used.

** X addresses assigned to this module indicate a broken transmitter.



NOTE 1: This module can be configured to operate in unipolar mode which generates a range of values from 0 to 65535 (instead of -32768 to 32767). Use the “:U”(unsigned) cast operator to get the proper representation of the data when using a module that is configured for unipolar. For example: WX0:U, WX1:U.

Analog I/O Modules Overview- continued

Module Control Byte

Analog output modules have a Module Control Byte that is used to configure some options for the outputs. In the module addressing, this byte shows up as eight Discrete Output (Y) Bits.

- Y0 = Outputs Enabled
- Y(0+1) = Unipolar/Bipolar
- Y(0+2) = 5V/10V Range
- Y(0+3) = 0–20mA/4–20mA
- Y((0+4) through (0+7)) = Reserved

When an analog output module is added to a Do-more project, a Module Configuration with default Module Control Byte values is created. Its settings can be changed under Module Configuration by double-clicking the Module Name or by selecting the New Config or Edit Config buttons on the right hand side.

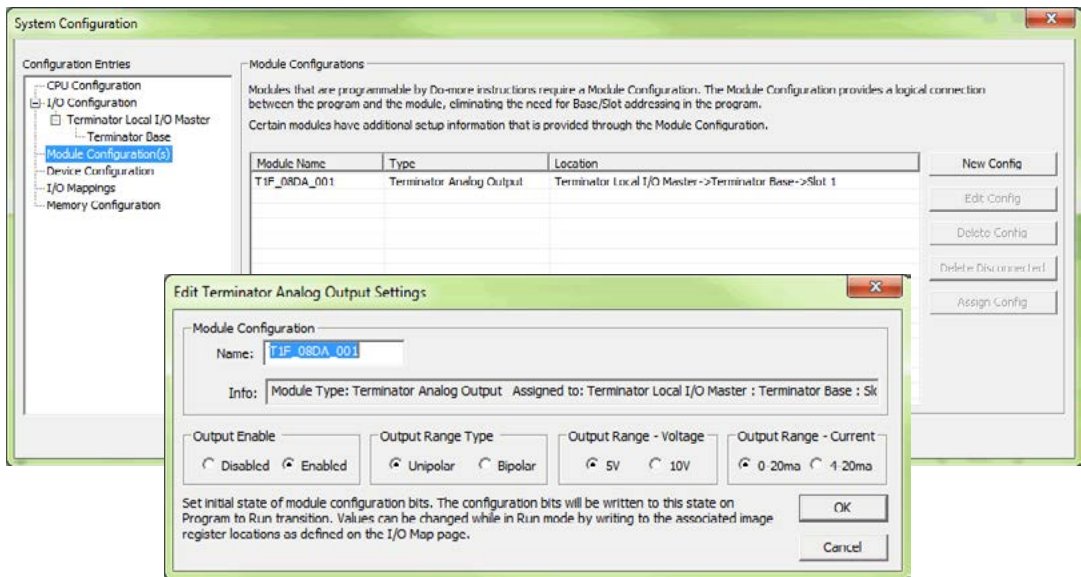

The Do-more T1H Series CPU will write the settings from the Module Configuration into the modules before going to Run mode. The Y Bits can optionally be used to change the Module Control Byte setting within the program.

Analog I/O Modules Overview- continued

You can check which X, Y, WX and WY addresses are assigned to each analog I/O module in the I/O Mapping tab of the System Configuration window, as shown below.

Select the pull-down menu PLC > System Configuration to open the System Configuration window and click the I/O Mapping tab.

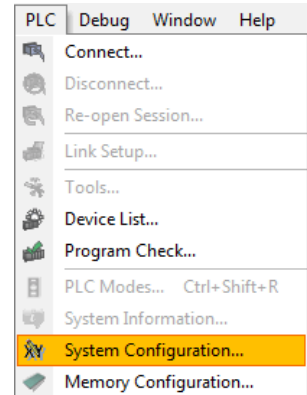

The screenshot shows the 'System Configuration' window with the 'I/O Map' tab selected. The window is divided into several sections:

- Configuration Entries:** A tree view on the left showing 'I/O Configuration' > 'Terminator Local I/O Master' > 'Terminator Base' > 'Module Configuration(s)' > 'I/O Mapping' (selected).
- I/O Map Table:** A table with columns: Slot, Mod ID, Mod Description, Slot I/O, X Map, Y Map, WX Map, and WY Map.

Slot	Mod ID	Mod Description	Slot I/O	X Map	Y Map	WX Map	WY Map
0 - Terminator Local I/O Master							
0 - Terminator Base - Right Click to edit base's default map addresses (X0, Y0, WX0, WY0)							
0	1102	T1K-08ND3	8X	X0-7			
1	1102	T1K-08ND3	8X	X8-15			
2	2532	T1F-08ADx	8X / 8WX	X16-23		WX0-7	
3	1242	J1K-081R	8Y		Y0-7		
4	"Empty"						
5	"Empty"						
6	"Empty"						
7	"Empty"						
8	"Empty"						
9	"Empty"						
10	"Empty"						
11	"Empty"						
12	"Empty"						
13	"Empty"						
14	"Empty"						
15	"Empty"						
16	"Empty"						
17	"Empty"						
- Annotations:** Three red boxes with arrows pointing to specific cells in the table:
 - 'I/O Slot Number' points to the 'Slot' column header.
 - 'Module ID' points to the 'Mod ID' column header.
 - 'Assigned X, Y, WX and WY Addresses' points to the 'X Map' column header.
- Mapping Mode:** A section at the bottom left with 'Auto' selected and 'Manual' unselected. A 'Clear Manual Entries' button is also present.
- Manual Mode Instructions:** A section at the bottom right explaining address assignment rules (e.g., bold for auto, gray for manual, red for errors).

T1F-08AD-1 - 8 Channel Analog Current Input

Specifications	
Number of Channels	8, single ended (1 common)
Input Ranges	0–20mA, 4–20mA, -20 to 20mA
Resolution	14 bit (13 bit plus sign bit)
Module Addressing	8 input bits (X-not used); 8 input words (WX)
Frequency Response	-3db @ 500Hz, -20db / decade
Input Resistance	250Ω
Absolute Maximum Ratings	8V max. Input
Conversion Time (Default: Normal Mode)	Normal Mode: 5ms per channel Fast Mode: 0.5 ms per channel (Fast Mode supported in module hardware version B or later, and only when using this analog module with the T1H-EBC(100) or T1H-PBC control module)*
Linearity Error	±2 count max.
Input Stability	±1 count
Full Scale Error (Offset Error not included)	16 counts max.
Offset Error	2 counts max.
Max. Full Scale Inaccuracy (% of full scale); all errors included	0.18% @ 25°C 0.36% @ 60°C
CPU Update Rate	1 channel per scan
Base Power Required	75mA @ 5VDC
External Module Power Supply Req.	18–30 VDC, 50mA, class 2
Recommended Fuse	0.032 A @ 5VDC, Series 217 Fast Acting
Operating Temperature	0 to 60°C (32 to 140°F)
Storage Temperature	-20 to 70°C (-4 to 158°F)
Accuracy vs. Temperature	±50ppm / °C max. full scale
Relative Humidity	5 to 95% (non-condensing)
Environmental Air	No corrosive gases permitted
Vibration	MIL STD 810C 514.2
Shock	MIL STD 810C 516.2
Noise Immunity	NEMA ICS3-304
Weight	136g

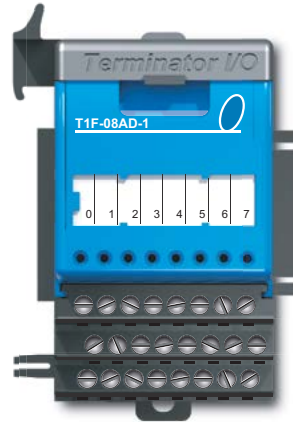

Input Range/Resolution

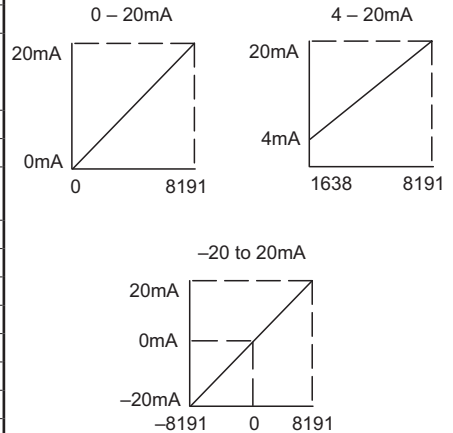

* Note: T1H-PBC was discontinued 8/2020; no replacement available

Equivalent Input Circuit

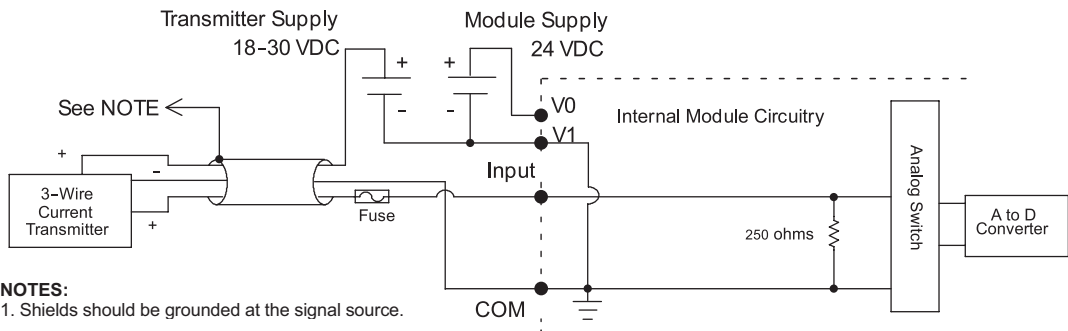

NOTES:
1. Shields should be grounded at the signal source.

T1F-08AD-2 - 8 Channel Analog Voltage Input

Specifications	
Number of Channels	8, single ended (1 common)
Input Ranges	0–5 V, 0–10 V, ±5V, ±10V
Resolution	14 bit (13 bit plus sign bit)
Module Addressing	8 input bits (X-not used); 8 input words (WX)
Frequency Response	-3db @ 500Hz, -20db / decade
Input Resistance	200kΩ min.
Absolute Maximum Ratings	Fault Protected Input, 130V (rms)/ 100VDC
Conversion Time (Default: Normal Mode)	Normal Mode: 5ms per channel Fast Mode: 0.5 ms per channel (Fast Mode supported in module hardware version B or later, and only when using this analog module with the T1H-EBC(100) or T1H-PBC control module)
Linearity Error	±2 count max.
Input Stability	±1 count
Calibration Full Scale Error	8 counts max.
Calibration Offset Error	2 counts max.
Max. Full Scale Inaccuracy (% of full scale); all errors included	0.08% @ 25°C 0.26% @ 60°C
CPU Update Rate	1 channel per scan
Base Power Required	75mA @ 5VDC
External Module Power Supply Req.	18–30 VDC, 50mA, class 2
Operating Temperature	0 to 60°C (32 to 140°F)
Storage Temperature	-20 to 70°C (-4 to 158°F)
Accuracy vs. Temperature	±50ppm / °C max. full scale
Relative Humidity	5 to 95% (non-condensing)
Environmental Air	No corrosive gases permitted
Vibration	MIL STD 810C 514.2
Shock	MIL STD 810C 516.2
Noise Immunity	NEMA ICS3-304
Weight	136g

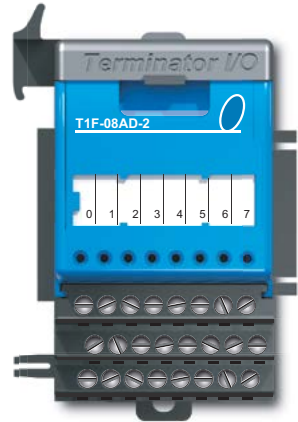

Input Range/Resolution

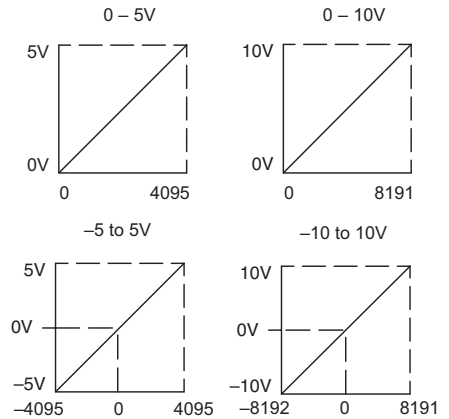

Equivalent Input Circuit

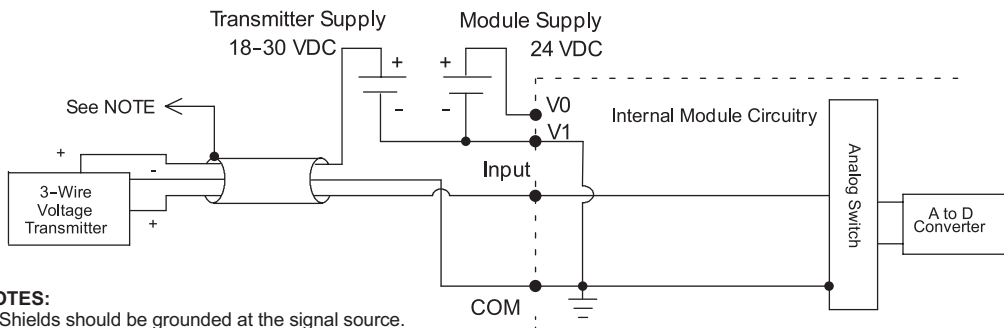

NOTES:

1. Shields should be grounded at the signal source.

T1F-16AD-1 - 16 Channel Analog Current Input

Specifications	
Number of Channels	16, single ended (1 common)
Input Ranges	0–20mA, 4–20mA, -20 to 20mA
Resolution	14 bit (13 bit plus sign bit)
Module Addressing	16 input bits (X-not used); 16 input words (WX)
Frequency Response	-3db @ 500Hz, -20db / decade
Input Resistance	250Ω
Absolute Maximum Ratings	8V max. Input
Conversion Time	5ms per channel
Linearity Error	±2 count max.
Input Stability	±1 count
Full Scale Error (Offset Error not included)	16 counts max.
Offset Error	2 counts max.
Max. Full Scale Inaccuracy (% of full scale); all errors included	0.18% @ 25°C 0.36% @ 60°C
CPU Update Rate	1 channel per scan
Base Power Required	75mA @ 5VDC
External Module Power Supply Req.	18–30 VDC, 50mA, class 2
Recommended Fuse	0.032 A @ 5VDC
Operating Temperature	0 to 60°C (32 to 140°F)
Storage Temperature	-20 to 70°C (-4 to 158°F)
Accuracy vs. Temperature	±50ppm / °C max. full scale
Relative Humidity	5 to 95% (non-condensing)
Environmental Air	No corrosive gases permitted
Vibration	MIL STD 810C 514.2
Shock	MIL STD 810C 516.2
Noise Immunity	NEMA ICS3-304
Weight	168g

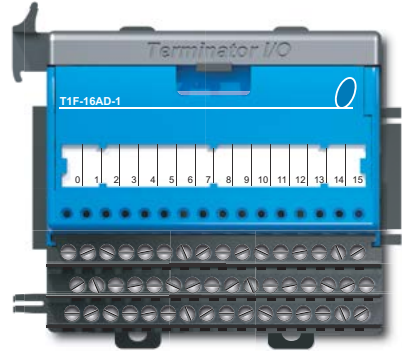

Input Range/Resolution

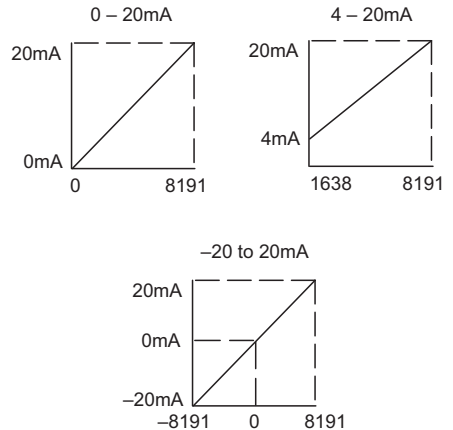

Equivalent Input Circuit

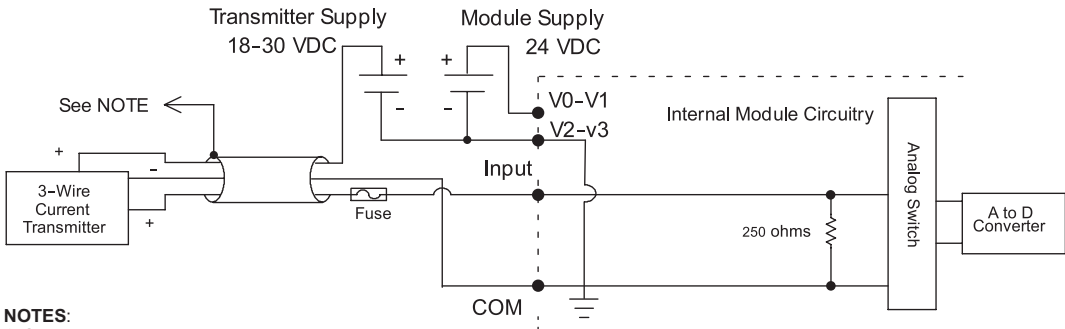

NOTES:

1. Shields should be grounded at the signal source.

T1F-16AD-2 - 16 Channel Analog Voltage Input

Specifications	
Number of Channels	16, single ended (1 common)
Input Ranges	0–5 V, 0–10 V, ±5V, ±10V
Resolution	14 bit (13 bit plus sign bit)
Module Addressing	16 input bits (X-not used); 16 input words (WX)
Frequency Response	-3db @ 500Hz, -20db / decade
Input Resistance	200kΩ min.
Absolute Maximum Ratings	Fault Protected Input, 130V (rms)/ 100VDC
Conversion Time	5ms per channel
Linearity Error	±2 count max.
Input Stability	±1 count
Calibration Full Scale Error	8 counts max.
Calibration Offset Error	2 counts max.
Max. Full Scale Inaccuracy (% of full scale); all errors included	0.08% @ 25°C 0.26% @ 60°C
CPU Update Rate	1 channel per scan
Base Power Required	75mA @ 5VDC
External Module Power Supply Req.	21.6–26.4 VDC, 50mA, class 2
Operating Temperature	0 to 60°C (32 to 140°F)
Storage Temperature	-20 to 70°C (-4 to 158°F)
Accuracy vs. Temperature	±50ppm / °C max. full scale
Relative Humidity	5 to 95% (non-condensing)
Environmental Air	No corrosive gases permitted
Vibration	MIL STD 810C 514.2
Shock	MIL STD 810C 516.2
Noise Immunity	NEMA ICS3-304
Weight	160g

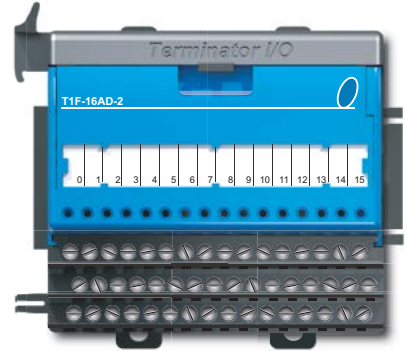

Input Range/Resolution

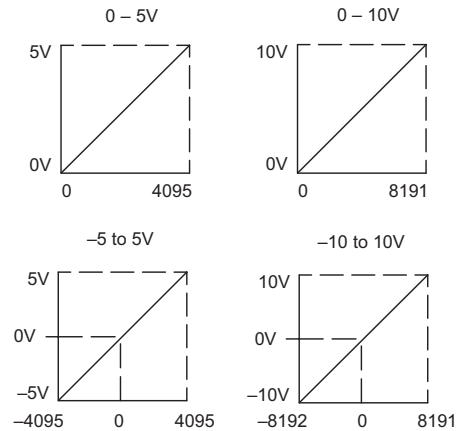

Equivalent Input Circuit

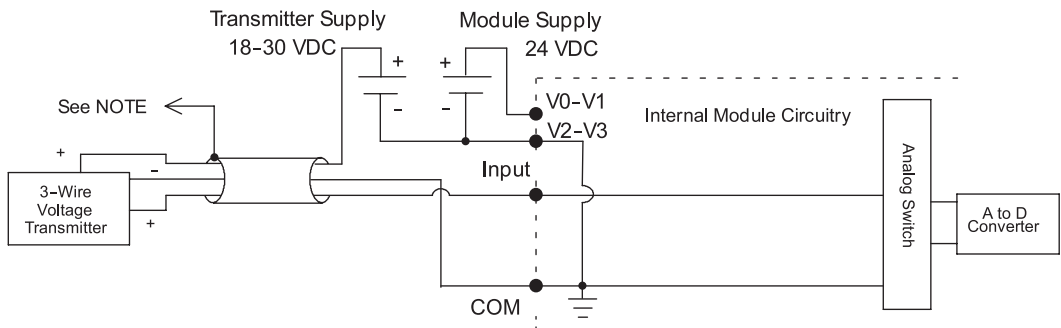

NOTES:
1. Shields should be grounded at the signal source.

T1F-16RTD - 16 Channel RTD Input

Specifications	
Number of Channels	16
Resolution	±0.1°C or °F
Module Addressing	16 input bits (X-broken transmitter); 16 input words (WX)
Common Mode Range	0-5 VDC
Notch Filter	> 50db notches @ 50/60Hz; f - 3db = 13.1 Hz
Absolute Max. Ratings	±50VDC
Converter Type	Charge balancing, 24-bit
Sampling Rate	140ms / channel
CPU Update Rate	1 channel per scan
Base Power Required	150mA @ 5VDC
Operating Temperature	0 to 60°C (32 to 140°F)
Temperature Drift	25ppm / °C (max.)
Maximum Inaccuracy	±1°C
RTD Excitation Current	200µA
Relative Humidity	5 to 95% (non-condensing)
Environmental Air	No corrosive gases permitted
Vibration	MIL STD 810C 514.2
Shock	MIL STD 810C 516.2
Noise Immunity	NEMA ICS3-304
Weight	168g

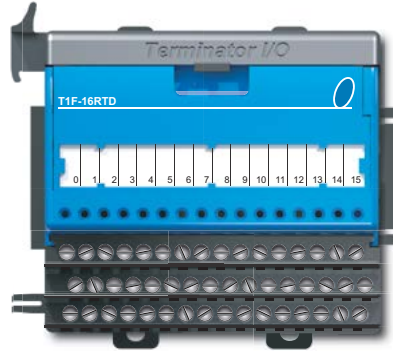

RTD Input Ranges	
RTD Type	Range
Pt100Ω	-200 to 850°C (-328 to 1562°F)
Pt1000Ω	-200 to 595°C (-328 to 1103°F)
jPt100Ω	-38 to 450°C (-36 to 842°F)
Type CU - 10 / 25	-200 to 260°C (-328 to 500°F)
120Ω Nickel	-80 to 260°C (-112 to 500°F)

Equivalent Input Circuit

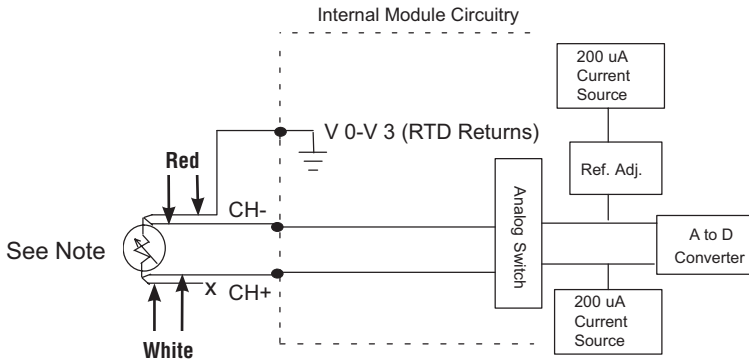

NOTES:

1. If an RTD sensor has four wires, the plus sense wire should be left unconnected as shown.

T1F-16RTD - 16 Channel RTD Input - continued

Setting Module Jumpers

Select Number of Channels

Number of Channels	Jumper			
	CH+1	CH+2	CH+3	CH+4
1				
2	X			
3		X		
4	X	X		
5			X	
6	X		X	
7		X	X	
8	X	X	X	
9				X
10	X			X
11		X		X
12	X	X		X
13			X	X
14	X		X	X
15		X	X	X
16	X	X	X	X

X = Jumper Installed
Blank Space = Jumper Removed

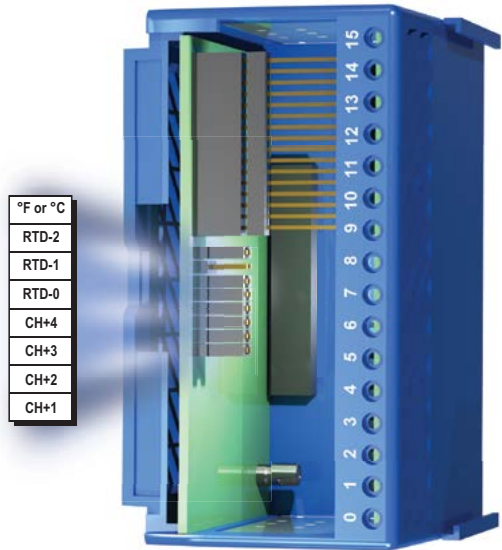

Select Input Type

RTD Input	Jumper		
	RTD-0	RTD-1	RTD-2
Pt100Ω	X	X	
Pt1000Ω			X
jPt100Ω		X	
Type CU-10Ω			
Type CU-25Ω	X		
120Ω Nickel	X		X

X = Jumper Installed
Blank Space = Jumper Removed

Select Temperature Units

Temperature Unit	Jumper
	°F or °C
°F	X
°C	

X = Jumper Installed
Blank Space = Jumper Removed

T1F-16TMST - 16 Channel Thermistor Input

Specifications	
Number of Channels	16
Resolution	+ / - 0.1° C or °F
Input Impedance	> 1MΩ
Common Mode Range	0 - 5 VDC
Absolute Max. Ratings	+ / - 50 VDC
Converter Type	Charge balancing, 24 - bit
Sampling Rate	140 ms / channel
Master Update Rate	16 channels per scan max.
Input Points Required	512 discrete pts. or 16 dwords (d (double) word = 32 bit word) Network Interface dependent
Base Power Required	150 mA @ 5 VDC
Operating Temperature	0° to 60° C (32° to 140° F)
Storage Temperature	-20° to 70° C (-4° to 158° F)
Temperature Drift	25 ppm / °C (max.)
Maximum Inaccuracy ¹	+ / - 1° C
Excitation Current	10 μA
Electrical Isolation	1500VDC field wire to backplane
Relative Humidity	5 to 95% (non-condensing)
Environmental Air	No corrosive gases permitted
Vibration	IEC 60068-2-6 (Test FC)
Shock	IEC 60068-2-27 (Test Ea)
Noise Immunity	EN61131-2:2007 ²
Recommended Cable	AutomationDirect P/N: PLTC3-18-1S-XXX Belden 8761 or equivalent
Weight	168 g

¹ "Accuracy" pertains to module only and does not include tolerances of thermistor element, wiring resistance, etc. For example, 22 gauge wire is 0.016Ω per foot, so 200 feet of wire adds 3.2Ω.

² Meets EMC & Safety Requirements

Thermistor Input Ranges	
Input Ranges	Range
10K-AN (Type 3)	-40° to 150° C (-40° to 300° F)
10K-CP (Type 2)	-40° to 150° C (-40° to 300° F)
5K	-40° to 150° C (-40° to 300° F)
3K	-40° to 150° C (-40° to 300° F)
2252	-40° to 150° C (-40° to 300° F)
1.8K	-40° to 150° C (-40° to 300° F)

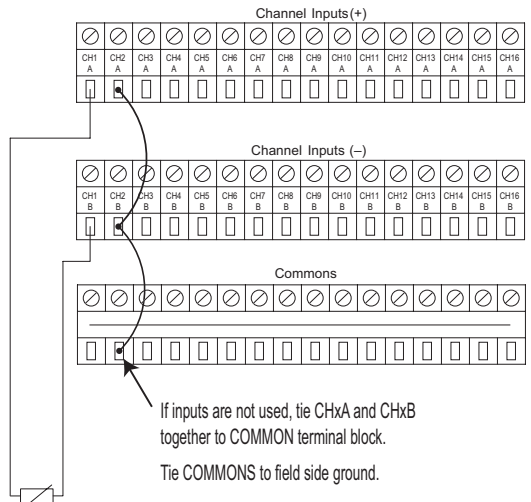
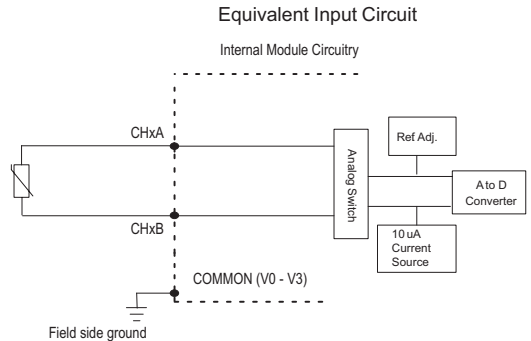
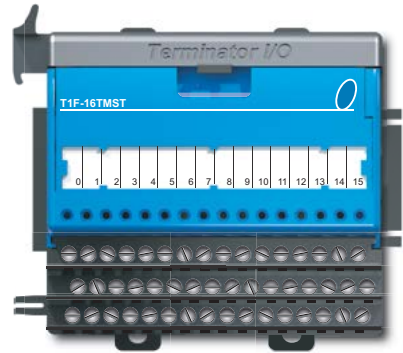

T1F-16TMST - 16 Channel Thermistor Input - continued

Setting Module Jumpers

Select Number of Channels

Number of Channels	Jumper			
	CH+1	CH+2	CH+3	CH+4
1				
2	X			
3		X		
4	X	X		
5			X	
6	X		X	
7		X	X	
8	X	X	X	
9				X
10	X			X
11		X		X
12	X	X		X
13			X	X
14	X		X	X
15		X	X	X
16	X	X	X	X

X = Jumper Installed
Blank Space = Jumper Removed

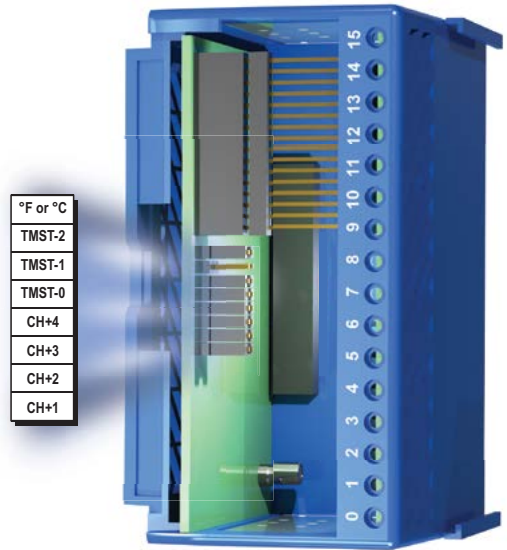

Select Input Type

Thermistor Input	Jumper		
	TMST-0	TMST-1	TMST-2
10K-AN (Type 3)			
10K-CP (Type 2)	X		
5K		X	
3K	X	X	
2252			X
1.8K	X		X
Future use		X	X
Future use	X	X	X

X = Jumper Installed
Blank Space = Jumper Removed

Select Temperature Units

Temperature Unit	Jumper
	°F or °C
°F	X
°C	

X = Jumper Installed
Blank Space = Jumper Removed

T1F-14THM - 14 Channel Thermocouple Input

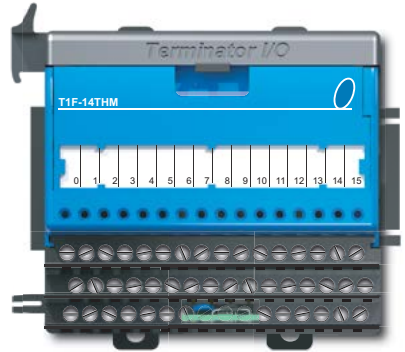

Specifications	
Use with I/O Module Base	T1K-16B screw type terminal base only
Number of Channels	14, differential
Common Mode Range	±5VDC
Module Addressing	16 input bits (X-broken transmitter); 16 input words (WX)
Common Mode Rejection	90db min. @ DC, 150db min. @ 50/60Hz
Input Impedance	1MΩ
Absolute Max. Ratings	Fault Protected Input ±50VDC
CPU Update Rate	1 channel per scan
Base Power Required	60mA @ 5VDC
External Power Required	24VDC ±5%, 70mA, class 2
Operating Temperature	0 to 60°C (-4 to 158°F)
Storage Temperature	-20 to 70°C (32 to 140°F)
Accuracy vs. Temperature	±5ppm/°C max. full scale
Relative Humidity	5 to 95% (non-condensing)
Environmental Air	No corrosive gases permitted
Vibration	MIL STD 810C 514.2
Shock	MIL STD 810C 516.2
Noise Immunity	NEMA ICS3-304
Weight	168g

Thermocouple Specifications	
Input Ranges	Type J -190 to 760°C (-310 to 1400°F) Type E -210 to 1000°C (-346 to 1832°F) Type K -150 to 1372°C (-238 to 2502°F) Type R 65 to 1768°C (149 to 3214°F) Type S 65 to 1768°C (149 to 3214°F) Type T -230 to 400°C (-382 to 752°F) Type B 529 to 1820°C (984 to 3308°F) Type N -70 to 1300°C (-94 to 2372°F) Type C 65 to 2320°C (149 to 4208°F)
Display Resolution	±0.1°C or ±0.1°F
Cold Junction Compensation	Automatic (CJC Part #: T1F-CJC)
Conversion Time	100ms per channel
Warm Up Time	30 minutes typical, ±1°C repeatability
Linearity Error	±0.05°C maximum, ±0.01°C typical
Maximum Inaccuracy	±3°C

Voltage Specifications	
Input Voltage Ranges	0-5 V, 0-156.25 mV ±5V, ±156.25 mV
Resolution	16 bit (1 in 65535)
Full Scale Calibration Error (Offset Error Included)	±13 counts typical ±33 counts maximum
Offset Calibration Error	±1 count max. @ 0V input
Linearity Error (End to End)	±1 count maximum
Maximum Inaccuracy	± 0.02% @ 25° C (77°F)

Input Range/Resolution

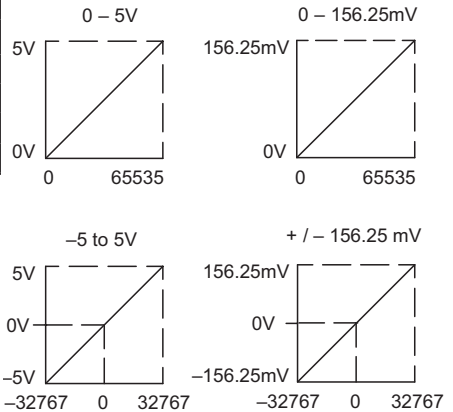

Equivalent Input Circuit

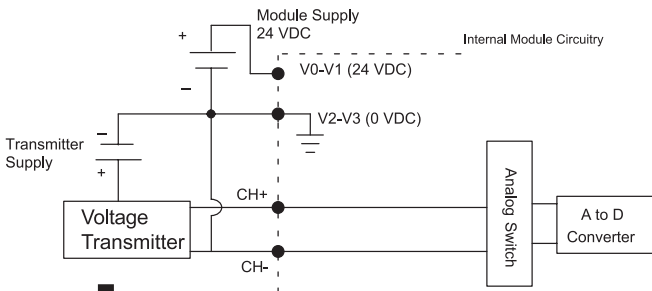

T1F-14THM - 14 Channel Thermocouple Input - continued

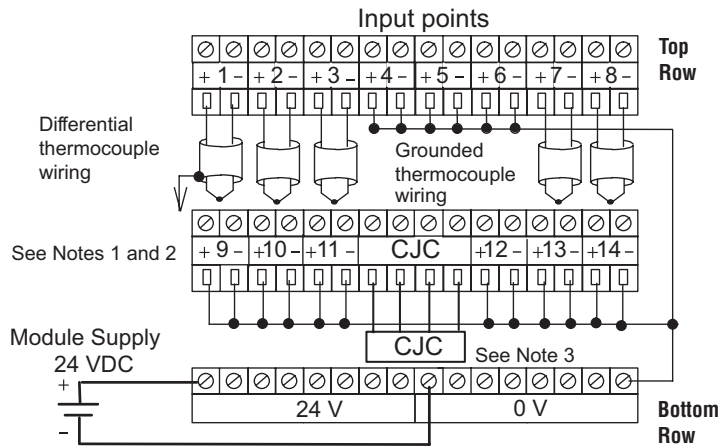

NOTES:

1. Shields should be grounded at the signal source.
2. Unused inputs should be connected to Common (0 VDC).
3. The Cold Junction Compensation (part #: T1F-CJC) temperature sense unit that comes with the module must be installed into the I/O base terminals to perform CJC of the thermocouple inputs.

Setting Module Jumpers (See Notes 1 and 2)

Select Number of Channels

Number of Channels	Jumper			
	CH+1	CH+2	CH+4	CH+8
1				
2	X			
3		X		
4	X	X		
5			X	
6	X		X	
7		X	X	
8	X	X	X	
9				X
10	X			X
11		X		X
12	X	X		X
13			X	X
14	X	X	X	X

X = Jumper Installed
Blank Space = Jumper Removed

Calibrate Enable
Units-1
Units-0
T/C Type 3
T/C Type 2
T/C Type 1
T/C Type 0
CH+8
CH+4
CH+2
CH+1

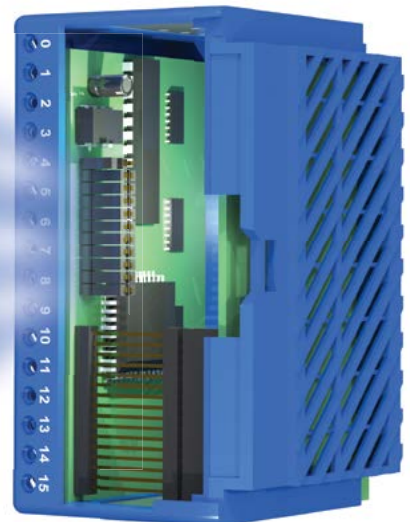

T1F-14THM - 14 Channel Thermocouple Input - continued

Select Input Type

Thermocouple/ Voltage Inputs	Jumper			
	T/C Type 0	T/C Type 1	T/C Type 2	T/C Type 3
J	X	X	X	X
K		X	X	X
E	X		X	X
R			X	X
S	X	X		X
T		X		X
B	X			X
N				X
C	X	X	X	
0-5 V		X	X	
±5V	X		X	
0-156.25 mV			X	
±156.25 mV	X	X		

X = Jumper Installed
Blank Space = Jumper Removed

Select the Conversion Units

(See Notes 3 and 4)

Jumper	Thermocouple Conversion Units	
	2's Complement	
	° F	° C
Units-0	X	
Units-1		

Jumper	Voltage Conversion Units	
	2's Complement	
Units-0	X	
Units-1		

X = Jumper Installed
Blank Space = Jumper Removed



NOTE 1: This module can be configured to operate in unipolar mode which generates a range of values from 0 to 65535 (instead of -32768 to 32767). Use the "U"(unsigned) cast operator to get the proper representation of the data when using a module that is configured for unipolar. For example: WX0:U, WX1:U.

NOTE 2: The Calibrate Enable jumper comes from the factory not installed. Installing the jumper disables the thermocouple active burn-out detection circuitry, which enables a thermocouple calibrator to be connected to the module. To make sure that the output of the thermocouple calibrator is within the 5 V common mode voltage range of the module, connect the negative side of the differential voltage input channel to the 0V terminal, then connect the thermocouple calibrator to the differential inputs (for example, Ch 3+ and Ch 3-).

NOTE 3: All thermocouple types are converted into a direct temperature reading with one implied decimal place. Negative temperatures are represented in 2's complement format. 2's complement data format is required to correctly display bipolar data on some operator interfaces.

NOTE 4: The bipolar voltage input ranges may be converted to a 16-bit 2's complement value.

T1F-08DA-1 - 8 Channel Analog Current Output

Specifications	
Number of Channels	8
Output Ranges	0–20 mA, 4–20 mA
Output Type	Single ended, 1 common
Resolution	12 bit (1 in 4096)
Module Addressing	8 output bits (Y-control byte); 8 output words (WY)
Max. Loop Supply	30VDC
Peak Output Voltage	30VDC
Load Impedance	0Ω min.
Max. Load (ohm) / Power Supply	620Ω/ 18V, 910Ω/ 24V, 1200Ω/ 30V
Min. Load (ohm) / Power Supply*	0Ω/ 24V, 350Ω/ 30V @ 40°C 250Ω/ 24V, 600Ω/ 30V @ 60°C
Linearity Error (end to end)	±2 counts max. ±0.05% of full scale max.
Conversion Settling Time	400μs max. full scale change
Full Scale Calibration Error	±12 counts max.
Offset Calibration Error	0–20 mA: ±5 counts max. 4–20 mA: ±6 counts max.
Accuracy vs. Temperature	±50ppm / °C, full scale calibration change
Max. Full Scale Inaccuracy (% of full scale) all errors included	0.2% @ 25°C 0.4% @ 60°C
CPU Update Rate	1 channel per scan
Base Power Required	75mA @ 5VDC
External Module Power Supply Req.	21.6–26.4 VDC, 150mA, class 2
Operating Temperature	0 to 60°C (32 to 140°F)
Storage Temperature	-20 to 70°C (-4 to 158°F)
Relative Humidity	5 to 95% (non-condensing)
Environmental Air	No corrosive gases permitted
Vibration	MIL STD 810C 514.2
Shock	MIL STD 810C 516.2
Noise Immunity	NEMA ICS3-304
Weight	145g

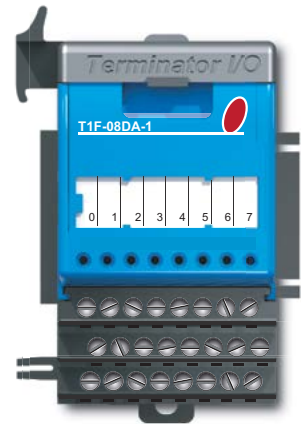

Output Range/Resolution

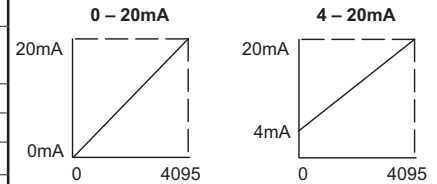

*Max. allowable output power dissipation. For example, at 60 °C and 24VDC, there must be a load of at least 250Ω on the output circuit. Smaller loads will damage the analog output circuit.

Equivalent Output Circuit

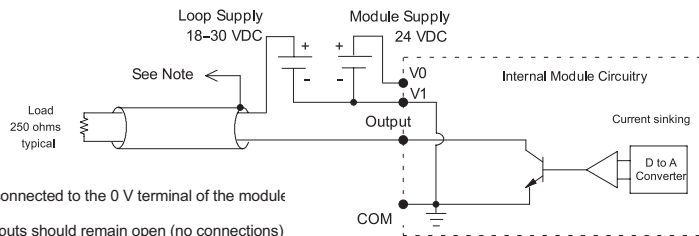

NOTES:

1. Shields should be connected to the 0 V terminal of the module the power supply.
2. Unused current outputs should remain open (no connections)

T1F-08DA-2 - 8 Channel Analog Voltage Output

Specifications	
Number of Channels	8
Output Ranges	0-5 V, 0-10 V, $\pm 5V$, $\pm 10V$
Output Type	Single ended, 1 common
Resolution	12 bit (1 in 4096)
Module Addressing	8 output bits (Y-control byte); 8 output words (WY)
Peak Output Voltage	15VDC
Load Impedance	4k Ω min.
Load Capacitance	0.01 μ F max.
Linearity Error (end to end)	± 2 counts max. $\pm 0.05\%$ of full scale max.
Conversion Settling Time	100 μ s max. full scale change
Full Scale Calibration Error	± 12 counts max.
Offset Calibration Error	10V ranges: ± 6 counts max. 5V ranges: ± 11 counts max.
Accuracy vs. Temperature	± 50 ppm / $^{\circ}C$, full scale calibration change
Max. Full Scale Inaccuracy (% of full scale) all errors and temp drift included	10V ranges: $\pm 0.2\%$ @ 25 $^{\circ}C$ $\pm 0.4\%$ @ 60 $^{\circ}C$ 5V ranges: $\pm 0.3\%$ @ 25 $^{\circ}C$ $\pm 0.5\%$ @ 60 $^{\circ}C$
CPU Update Rate	1 channel per scan
Base Power Required	75mA @ 5VDC
External Module Power Supply Req.	21.6 - 26.4 VDC, 150mA, class 2
Operating Temperature	0 to 60 $^{\circ}C$ (32 to 140 $^{\circ}F$)
Storage Temperature	-20 to 70 $^{\circ}C$ (-4 to 158 $^{\circ}F$)
Relative Humidity	5 to 95% (non-condensing)
Environmental Air	No corrosive gases permitted
Vibration	MIL STD 810C 514.2
Shock	MIL STD 810C 516.2
Noise Immunity	NEMA ICS3-304
Weight	145g

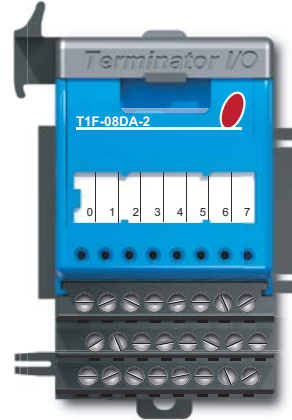

Unipolar Range/Resolution

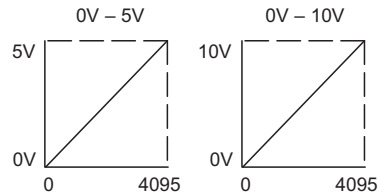

Bipolar Range/Resolution

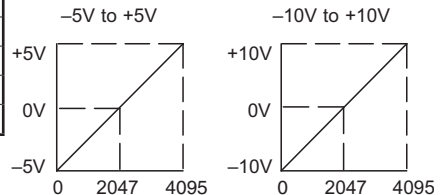

Equivalent Output Circuit

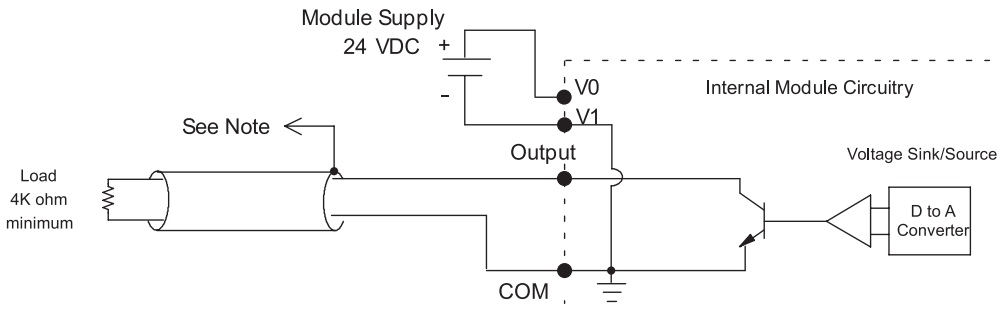

NOTES:

1. Shields should be connected to the 0 V terminal of the module or the 0 V terminal of the power supply.

T1F-16DA-1 - 16 Channel Analog Current Output

Specifications	
Number of Channels	16
Output Ranges	0–20mA, 4–20mA
Output Type	Single ended, 1 common
Resolution	12 bit (1 in 4096)
Module Addressing	8 output bits (Y-control byte); 16 output words (WY)
Max. Loop Supply	30VDC
Peak Output Voltage	30VDC
Max. Load (ohm) / Power Supply	620Ω / 18V, 910Ω / 24V, 1200Ω / 30V
Min. Load (ohm) / Power Supply*	0Ω / 24V, 350Ω / 30V @ 40°C 250Ω / 24V, 600Ω / 30V @ 60°C
Linearity Error (end to end)	±2 counts max. ±0.05% of full scale max.
Conversion Settling Time	400μs max. full scale change
Full Scale Calibration Error	±12 counts max.
Offset Calibration Error	0–20mA: ±5 counts max. 4–20mA: ±6 counts max.
Accuracy vs. Temperature	±50ppm / °C, full scale calibration change
Max. Full Scale Inaccuracy (% of full scale) all errors included	0.2% @ 25°C 0.4% @ 60°C
CPU Update Rate	1 channel per scan
Base Power Required	75mA @ 5VDC
External Module Power Supply Req.	21.6–26.4 VDC, 150mA, class 2
Operating Temperature	0 to 60°C (32 to 140°F)
Storage Temperature	-20 to 70°C (-4 to 158°F)
Relative Humidity	5 to 95% (non-condensing)
Environmental Air	No corrosive gases permitted
Vibration	MIL STD 810C 514.2
Shock	MIL STD 810C 516.2
Noise Immunity	NEMA ICS3-304
Weight	172g

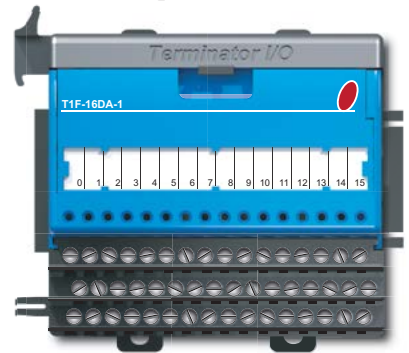

Output Range/Resolution

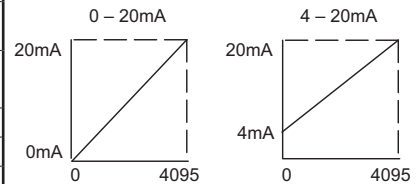

*Max. allowable output power dissipation. For example, at 60°C and 24VDC, there must be a load of at least 250Ω on the output circuit. Smaller loads will damage the analog output circuit.

Equivalent Output Circuit

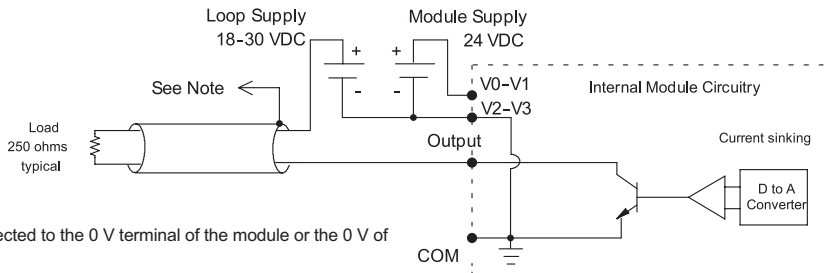

NOTES:

1. Shields should be connected to the 0 V terminal of the module or the 0 V of the power supply.

T1F-16DA-2 - 16 Channel Analog Voltage Output

Specifications	
Number of Channels	16
Output Ranges	0–5 V, 0–10 V, ±5V, ±10V
Output Type	Single ended, 1 common
Resolution	12 bit (1 in 4096)
Module Addressing	8 output bits (Y-control byte); 16 output words (WY)
Peak Output Voltage	15VDC
Load Impedance	4kΩ min.
Load Capacitance	0.01 μF max.
Linearity Error (end to end)	±2 counts max. ±0.05% of full scale max.
Conversion Settling Time	100μs max. full scale change
Full Scale Calibration Error	±12 counts max.
Offset Calibration Error	10V ranges: ±6 counts max. 5V ranges: ±11 counts max.
Accuracy vs. Temperature	±50ppm/°C, full scale calibration change
Max. Full Scale Inaccuracy (% of full scale) all errors and temp drift included	10V ranges: ±0.2% @ 25°C ±0.4% @ 60°C 5V ranges: ±0.3% @ 25°C ±0.5% @ 60°C
CPU Update Rate	1 channel per scan
Base Power Required	75mA @ 5VDC
External Module Power Supply Req.	21.6–26.4 VDC, 150mA, class 2
Operating Temperature	0 to 60°C (32 to 140°F)
Storage Temperature	-20 to 70°C (- 4 to 158°F)
Relative Humidity	5 to 95% (non-condensing)
Environmental Air	No corrosive gases permitted
Vibration	MIL STD 810C 514.2
Shock	MIL STD 810C 516.2
Noise Immunity	NEMA ICS3-304
Weight	172g

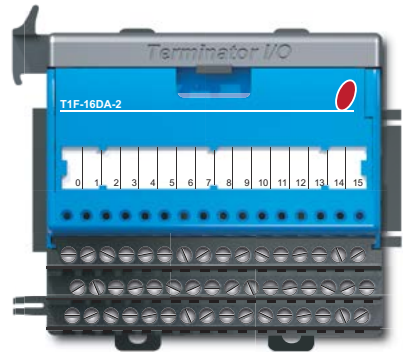

Unipolar Range/Resolution

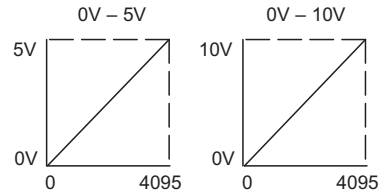

Bipolar Range/Resolution

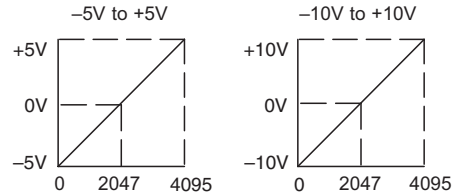

Equivalent Output Circuit

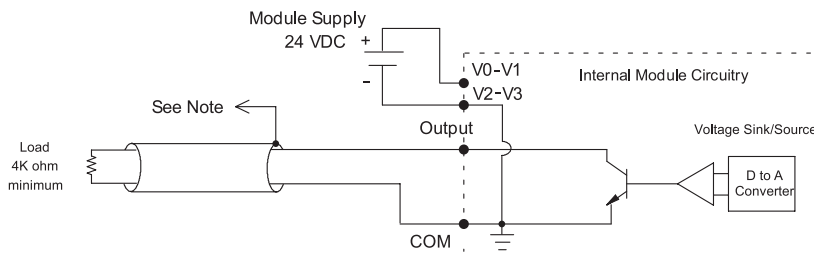

NOTES:

1. Shields should be connected to the 0 V terminal of the module or the 0 V of the power supply.

T1F-8AD4DA-1 - 8 Channel Analog Current Input / 4 Channel Analog Current Output

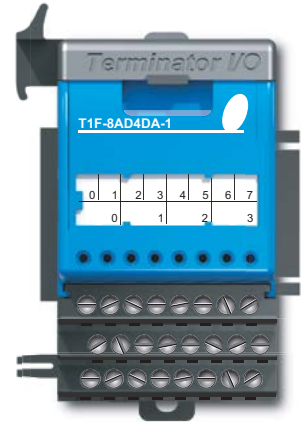

Module General Specifications	
CPU Update Rate	1 channel per scan
Base Power Required	75mA @ 5VDC
External Module Power Supply	21.6–26.4 VDC, 50mA, class 2 (plus 20mA per channel loop)
Operating Temperature	0 to 60° C (32 to 140°F)
Storage Temperature	-20 to 70°C (- 4 to 158°F)
Accuracy vs. Temperature	±50ppm/ °C max. full scale
Relative Humidity	5 to 95% (non-condensing)
Environmental Air	No corrosive gases permitted
Vibration	MIL STD 810C 514.2
Shock	MIL STD 810C 516.2
Noise Immunity	NEMA ICS3-304
Weight	136g

Input Channel Specifications	
Number of Channels	8, single ended (1 common)
Input Ranges	0–20mA, 4–20mA, - 20 to 20mA
Resolution	14 bit (13 bit plus sign bit)
Module Addressing	8 input bits (X-not used); 8 input words (WX)
Frequency Response	-3db @ 100Hz, -20db/ decade
Input active low-pass filter	
Input Resistance	250Ω
Absolute Maximum Ratings	8V max. Input
Conversion Time	5ms per channel
Linearity Error	±2 count max.
Input Stability	±1 count
Full Scale Error (Offset Error not included)	16 counts max.
Offset Error	2 counts max.
Max. Full Scale Inaccuracy (% of full scale); all errors included	0.18% @ 25°C 0.36% @ 60°C
Recommended Fuse	0.032 A, Series 217 Fast Acting

Input Range/Resolution

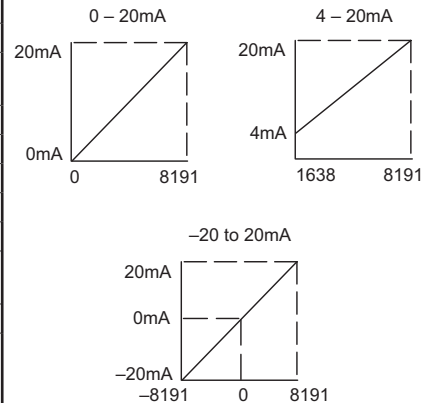

Equivalent Input Circuit

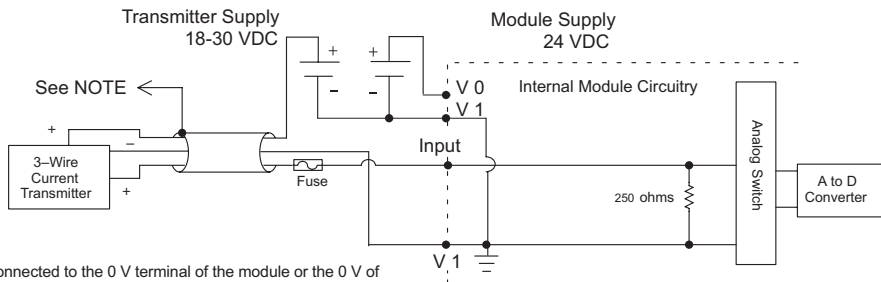

NOTES:
1. Shields should be connected to the 0 V terminal of the module or the 0 V of the power supply.

T1F-8AD4DA-1 - continued

Output Channel Specifications	
Number of Channels	4, sink/source; individually configured by wiring
Output Range	4–20mA
Output Type	Single ended, 1 common
Resolution	12 bit (1 in 4096)
Module Addressing	8 output bits (Y-control byte); 4 output words (WY)
Maximum Loop Supply	30VDC
Source Load (ohms) / Loop Power Supply	0–400 Ω / 18–30 V
Sink Load (ohm) / Loop Power Supply	0–600 Ω / 18V, 0–900 Ω / 24V, 0–1200 Ω / 30V
Total Load (Sink plus Source)	600Ω / 18V, 900Ω / 24V, 1200Ω / 30V

Output Channel Specifications	
Linearity Error (end to end)	±2 count maximum ±0.050% of full scale maximum
Conversion Settling Time	400μs maximum full scale change
Full Scale Calibration Error (Note: source error depends upon the load from source terminal to ground)	SINK: ±12 counts max. @ any load SOURCE: ±26 counts max. @ 400Ω load ±18 counts max. @ 250Ω load ±12 counts max. @ 125Ω load
Offset Calibration Error	SINK: ±6 counts max. @ any load SOURCE: ±10 counts max. @ 400Ω load ±8 counts max. @ 250Ω load ±6 counts max. @ 125Ω load
Max. Full Scale Inaccuracy (% of full scale); all errors included	SINK: (any load) 0.3% @ 25°C (any load) 0.5% @ 60°C SOURCE: 400Ω load 0.63% @ 25°C 400Ω load 0.83% @ 60°C 250Ω load 0.44% @ 25°C 250Ω load 0.64% @ 60°C 125Ω load 0.30% @ 25°C 125Ω load 0.50% @ 60°C

Equivalent Output Circuit

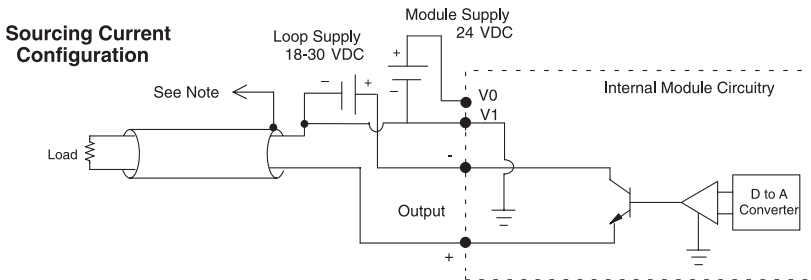

Output Range/Resolution

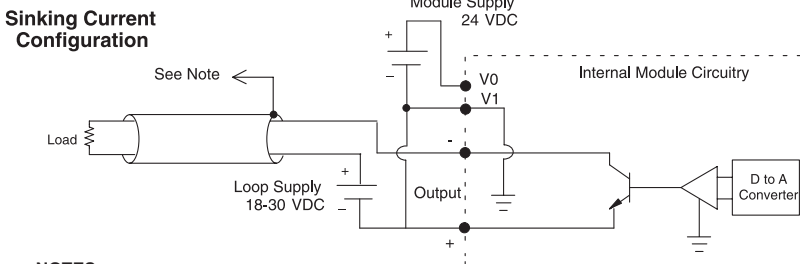
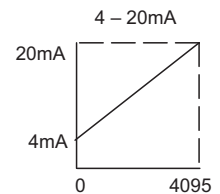

NOTES:

1. Shields should be connected to the 0 V terminal of the module or the 0 V of the power supply.

T1F-8AD4DA-2 - 8 Channel Analog Voltage Input / 4 Channel Analog Voltage Output

Module General Specifications	
CPU Update Rate	1 channel per scan
Base Power Required	75mA @ 5VDC
External Module Power Supply	21.6–26.4 VDC, 70mA, class 2
Operating Temperature	0 to 60°C (32 to 140°F)
Storage Temperature	-20 to 70°C (-4 to 158°F)
Accuracy vs. Temperature	±50ppm / °C max. full scale
Relative Humidity	5 to 95% (non-condensing)
Environmental Air	No corrosive gases permitted
Vibration	MIL STD 810C 514.2
Shock	MIL STD 810C 516.2
Noise Immunity	NEMA ICS3-304
Weight	136g

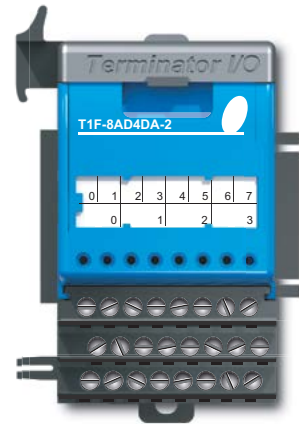

Input Channel Specifications	
Number of Channels	8, single ended (1 common)
Input Ranges	0–5 V, 0–10 V, ±5V, ±10V
Resolution	14 bit (13 bit plus sign bit)
Module Addressing	8 input bits (X-not used); 8 input words (WX)
Frequency Response	-3db @ 500Hz, - 20db / decade
Input Resistance	200kΩ min.
Absolute Maximum Ratings	Fault Protected Input, 130V (rms) or 100VDC
Conversion Time	5.5 ms per channel
Linearity Error	±2 count max.
Input Stability	±1 count
Calibration Full Scale Error	8 counts max.
Calibration Offset Error	2 counts max.
Max. Full Scale Inaccuracy (% of full scale); all errors included	0.08% @ 25°C 0.26% @ 60°C
External Transmitter Power Supply	18–30 VDC, 70mA, class 2

Input Range/Resolution

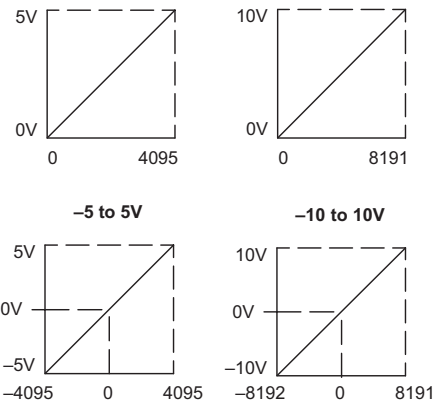

Equivalent Input Circuit

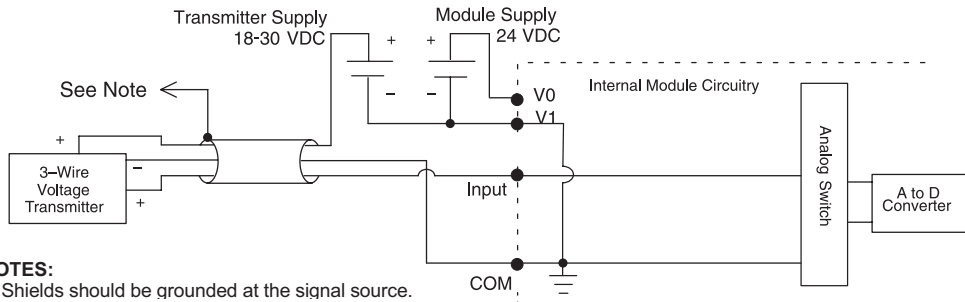

NOTES:

1. Shields should be grounded at the signal source.

T1F-8AD4DA-2 - continued

Output Channel Specifications	
Number of Channels	4
Output Ranges	0–5 V, 0–10 V, ±5V, ±10V
Output Type	Single ended, 1 common
Resolution	12 bit (1 in 4096)
Module Addressing	8 output bits (Y-control byte); 4 output words (WY)
Peak Output Voltage	15VDC
Load Impedance	4kΩ minimum
Load Capacitance	0.01 μF maximum
Linearity Error (end to end)	±2 count maximum ±0.050% of full scale maximum
Conversion Settling Time	300μs maximum full scale change
Full Scale Calibration Error	±12 counts maximum
Accuracy vs. Temperature	±50ppm/ °C; full scale calibration change
Offset Calibration Error	10V ranges: ±5 counts 5V ranges: ±9 counts
Max. Full Scale Inaccuracy (% of full scale); all errors and temperature drift included	10V ranges: ±0.2% @ 25°C ±0.4% @ 60°C 5V ranges: ±0.3% @ 25°C ±0.5% @ 60°C
CPU Update Rate	1 channel per scan

Unipolar Range/Resolution

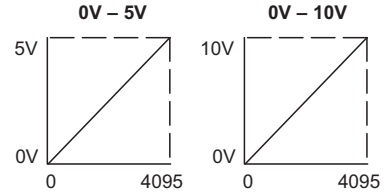

Bipolar Range/Resolution

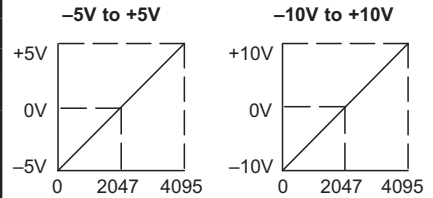

Equivalent Output Circuit

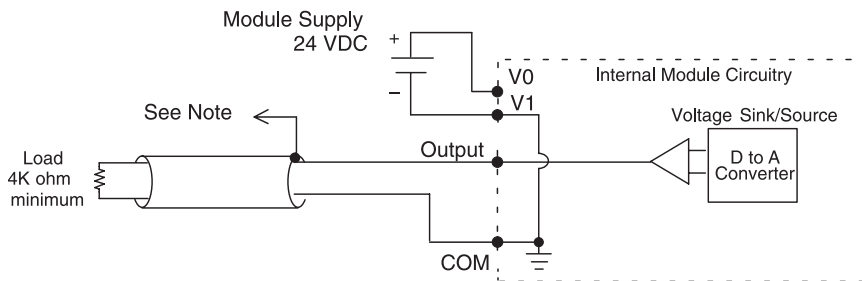

NOTES:

1. Shields should be connected to the 0 V terminal of the module or the 0 V of the power supply.