

SPECIFICATIONS - DISCRETE I/O MODULES



In This Chapter:

Discrete I/O Modules Overview	5-2
Discrete Input Modules	5-2
Discrete Output Modules	5-2
T1K-08ND3 - DC Input	5-3
T1K-16ND3 - DC Input	5-5
T1K-08NA-1 - AC Input.....	5-7
T1K-16NA-1 - AC Input.....	5-8
T1K-08TD1 - DC Output	5-9
T1K-16TD1 - DC Output	5-10
T1K-08TD2-1 - DC Output.....	5-11
T1K-16TD2-1 - DC Output.....	5-12
T1H-08TDS - Isolated DC Output.....	5-13
T1K-08TA - AC Output.....	5-14
T1K-16TA - AC Output.....	5-15
T1K-08TAS - Isolated AC Output.....	5-16
T1K-08TR - Relay Output.....	5-17
T1K-16TR - Relay Output.....	5-18
T1K-08TRS - Isolated Relay Output.....	5-19

Discrete I/O Modules Overview

There are 15 discrete I/O modules available. The specifications and wiring diagrams for these modules are found in this chapter. Each discrete I/O module is identified as an “Input” or “Output” module using the color coding scheme shown below. A blue dot on the front panel signifies an Input module and a red dot signifies an Output module.

Discrete Input Modules

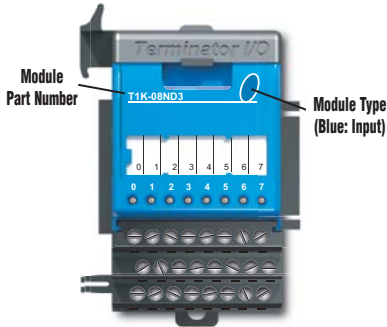

Discrete Input Modules			
Part Number	Number of Inputs	Description	See Page
T1K-08ND3	8	Sinking/Sourcing DC Input	5-4
T1K-16ND3	16	Sinking/Sourcing DC Input	5-6
T1K-08NA-1	8	AC Input	5-8
T1K-16NA-1	16	AC Input	5-9

Discrete Output Modules

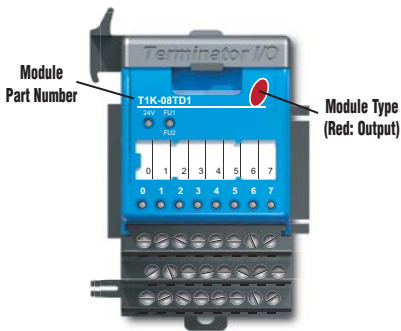

Discrete Output Modules			
Part Number	Number of Outputs	Description	See Page
T1K-08TD1	8	Sinking DC Output	5-10
T1K-16TD1	16	Sinking DC Output	5-11
T1K-08TD2-1	8	Sourcing DC Output	5-12
T1K-16TD2-1	16	Sourcing DC Output	5-13
T1H-08TDS	8	Isolated Sinking/Sourcing DC Output	5-14
T1K-08TA	8	AC Output	5-15
T1K-16TA	16	AC Output	5-16
T1K-08TAS	8	Isolated AC Output	5-17
T1K-08TR	8	Relay Output	5-18
T1K-16TR	16	Relay Output	5-19
T1K-08TRS	8	Isolated Relay Output	5-20



WARNING: The T1H Series PLC does not support any Hot-Swap features.

T1K-08ND3 - DC Input

Specifications	
Inputs Per Module	8 (sink / source)
Commons Per Module	Ext. power: 2, isolated (4 pts. / com.) Int. power: 2, all 8 pts. internally connected
Operating Voltage	12–24 VDC
Input Voltage Range	10.8–26.4 VDC min. / max.
Peak Voltage	30VDC
Input Current (Typical)	4mA @ 12VDC, 8.5 mA @ 24VDC
Input Impedance	2.8 kΩ
ON Voltage Level	> 10.0 VDC
OFF Voltage Level	< 2.0 VDC
Min. ON Current	4mA
Max. OFF Current	0.5 mA
OFF to ON Response	2–8 ms, Typical: 4ms
ON to OFF Response	2–8 ms, Typical: 4ms
Base Power Requirements	35mA @ 5VDC
Status Indicators	Logic Side
Weight	70g

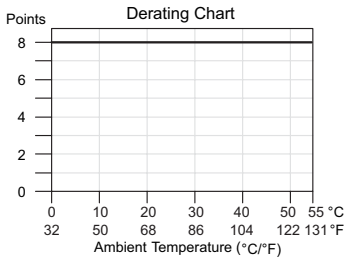

Note:
External Power,
Sink Module
Configuration
Shown

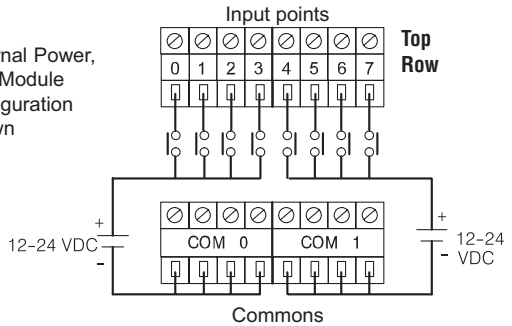

V 0 and V 1 supply 24 VDC
or 0 VDC if Internal Power
Jumper is selected



Jumper Selection

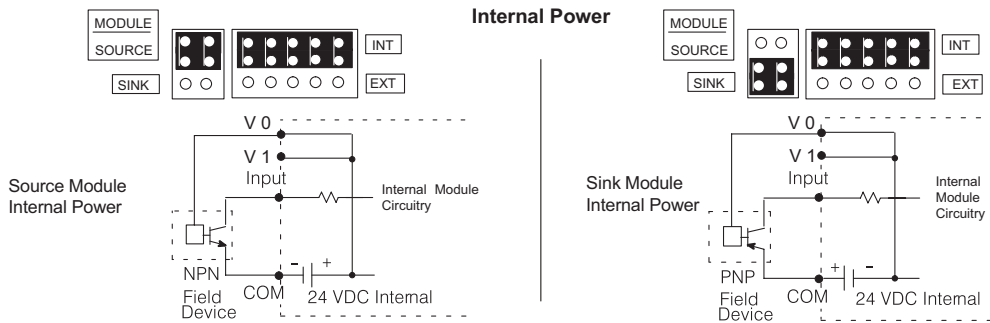
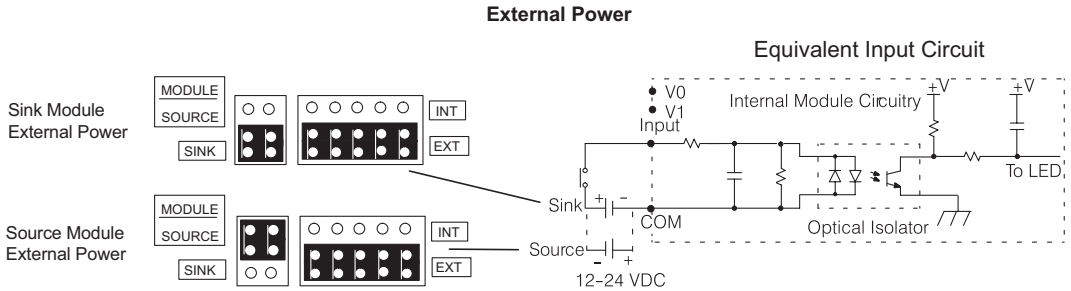

T1K-16ND3 - DC Input

Specifications	
Inputs Per Module	16 (sink / source)
Commons Per Module	Ext. power: 4, isolated (4 pts. / com.) Int. power: 4, all 16 pts. internally connected
Operating Voltage	12-24 VDC
Input Voltage Range	10.8 - 26.4 VDC min. / max.
Peak Voltage	30VDC
Input Current (Typical)	4mA @ 12VDC, 8.5 mA @ 24VDC
Input Impedance	2.8 kΩ
ON Voltage Level	>10.0 VDC
OFF Voltage Level	<2.0 VDC
Min. ON Current	4mA
Max. OFF Current	0.5 mA
OFF to ON Response	2-8 ms, Typical: 4ms
ON to OFF Response	2-8 ms, Typical: 4ms
Base Power Requirements	70mA @ 5VDC
Status Indicators	Logic Side
Weight	160g

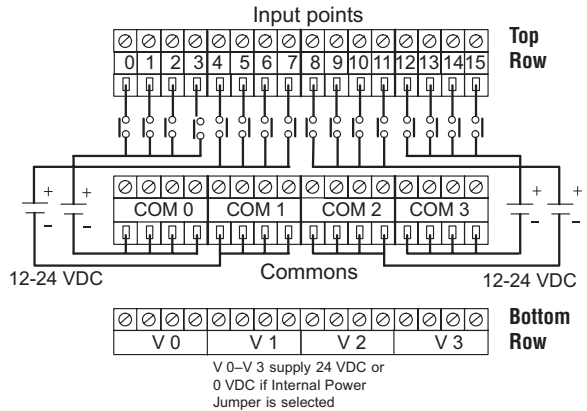
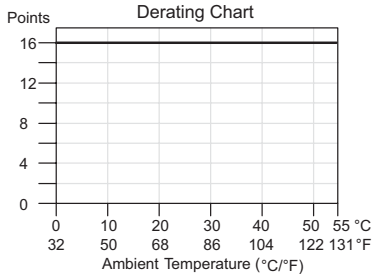
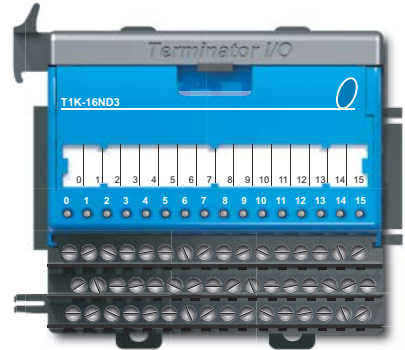

NOTE: When using external power, the module can be wired to either sink current or source current regardless of the module's sink/source jumper position. When using internal power, the sink/source jumpers determine the module's configuration."

Jumper Selection

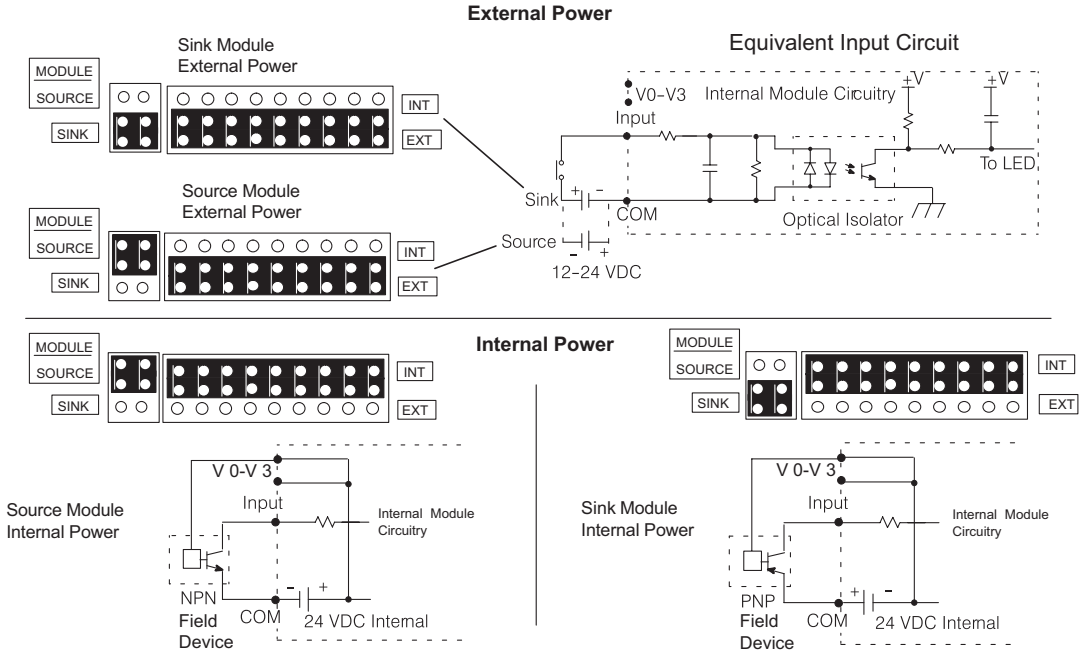

T1K-08NA-1 - AC Input

Specifications	
Inputs Per Module	8
Commons Per Module	2, 4 pts. / com. (Isolated)
Operating Voltage	90–120 VAC, 47–63 Hz
Input Voltage Range	80–132 VAC, 47–63 Hz min. / max.
Input Current	8mA @ 100VAC (50Hz) 10mA @ 100VAC (60Hz) 12mA @ 132VAC (50Hz) 15mA @ 132VAC (60Hz)
Input Impedance	14kΩ @ 50Hz, 12kΩ @ 60Hz
ON Current / Voltage	> 6mA @ 75VAC
OFF Current / Voltage	< 2.0 mA @ 20VAC
OFF to ON Response	< 40ms
ON to OFF Response	< 40ms
Base Power Requirements	35mA @ 5VDC
Status Indicators	Logic Side
Weight	70g

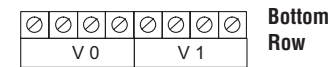
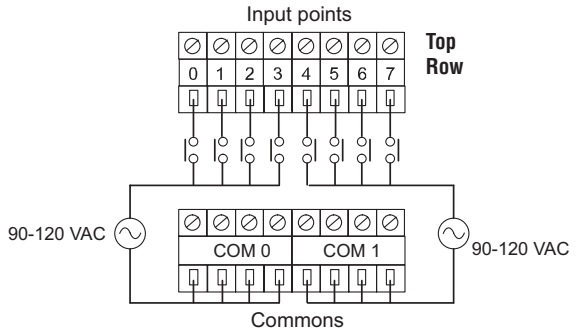
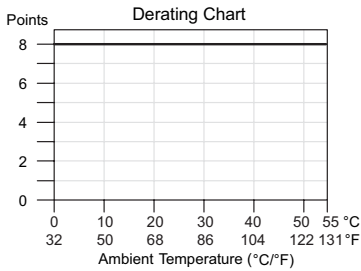

V 0, V 1 not used with AC Input Modules

Equivalent Input Circuit

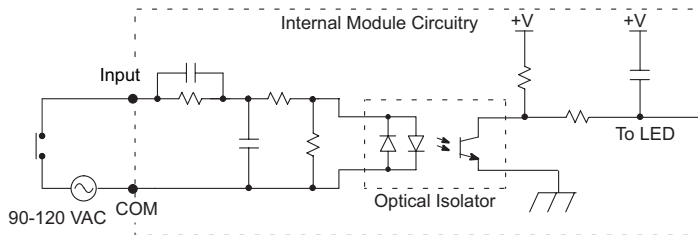

T1K-16NA-1 - AC Input

Specifications	
Inputs Per Module	16
Commons Per Module	4, 4 pts. / com. (Isolated)
Operating Voltage	90–120 VAC, 47–63 Hz
Input Voltage Range	80–132 VAC, 47–63 Hz min. / max.
Input Current	8mA @ 100VAC (50Hz) 10mA @ 100VAC (60Hz) 12mA @ 132VAC (50Hz) 15mA @ 132VAC (60Hz)
Input Impedance	14kΩ @ 50Hz, 12kΩ @ 60Hz
ON Current / Voltage	> 6mA @ 75VAC
OFF Current / Voltage	< 2.0 mA @ 20VAC
OFF to ON Response	< 40ms
ON to OFF Response	< 40ms
Base Power Requirements	70mA @ 5VDC
Status Indicators	Logic Side
Weight	120g

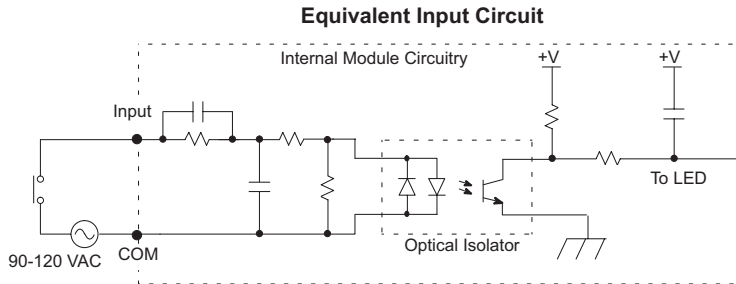
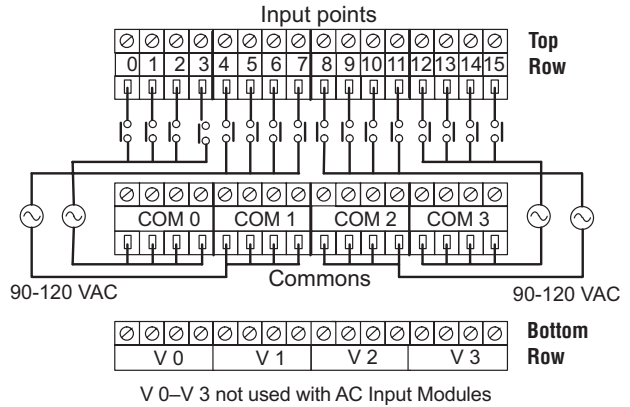
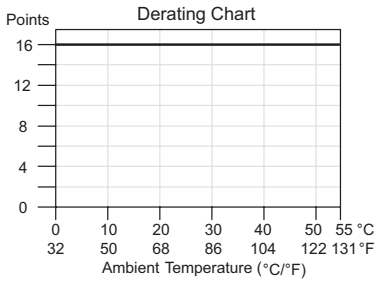

T1K-08TD1 - DC Output

Specifications	
Outputs Per Module	8 (sink)
Commons Per Module	2 internally connected
Operating Voltage Range	6–27 VDC
Output Voltage Range	5–30 VDC min. / max.
Peak Voltage	50VDC
Max. Load Current	1A / pt., 4A / common
Max. Leakage Current	15 μ A @ 30VDC
ON Voltage Drop	0.3 VDC @ 1.0 A
Max. Inrush Current	2A for 100ms
OFF to ON Response	< 10 μ s
ON to OFF Response	< 60 μ s
Base Power Requirements	100mA @ 5VDC
External Power Required	200mA max. @ 20–28 VDC
Status Indicators	Logic Side
Error Status Indicators (LEDs)	24V ON = low external power FU1 / FU2 ON = fuse 1 or fuse 2 blown
Fuses (User Replaceable)	2, (6.3 A, 250V / common), (4 pts. / fuse)
T1K-FUSE-1	NQ3 - 6.3 SOC corp.
Weight	85g

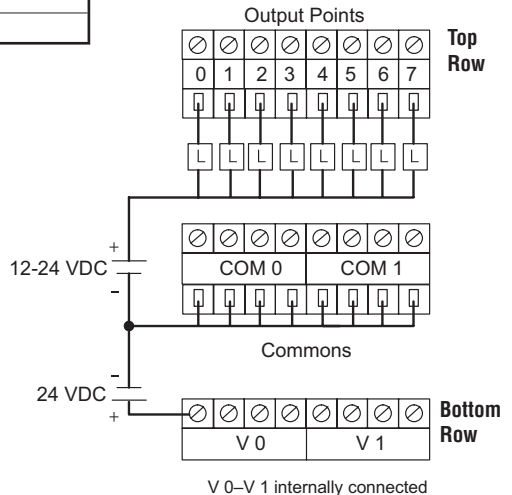
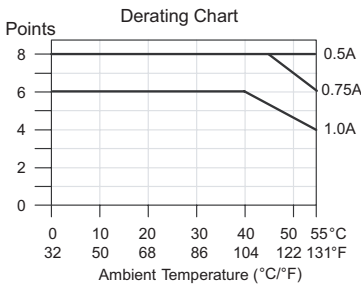
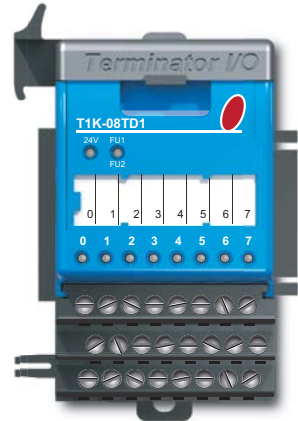

Equivalent Output Circuit

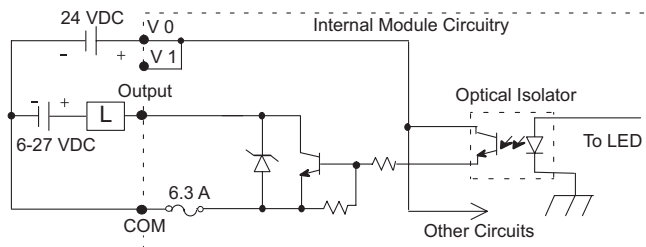

T1K-16TD1 - DC Output

Specifications	
Outputs Per Module	16 (sink)
Commons Per Module	4 internally connected
Operating Voltage Range	6–27 VDC
Output Voltage Range	5–30 VDC min. / max.
Peak Voltage	50VDC
Max. Load Current	1A / pt., 4A / common
Max. Leakage Current	15µA @ 30VDC
ON Voltage Drop	0.3 VDC @ 1.0 A
Max. Inrush Current	2A for 100ms
OFF to ON Response	< 10µs
ON to OFF Response	< 60µs
Base Power Requirements	200mA @ 5VDC
External Power Required	400mA max. @ 20–28 VDC
Status Indicators	Logic Side
Error Status Indicators (LEDs)	24V ON = low external power FU1 / FU2 ON = fuse 1 or 2 blown FU3 / FU4 ON = fuse 3 or 4 blown
Fuses (User Replaceable)	4, (6.3 A, 250V / common), (4 pts. / fuse)
T1K-FUSE-1	NQ3 - 6.3 SOC corp.
Weight	140g

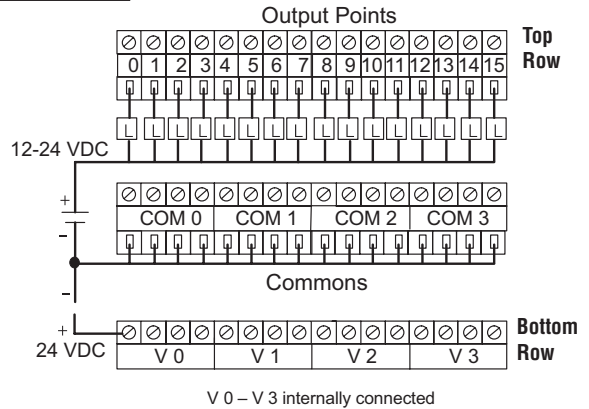
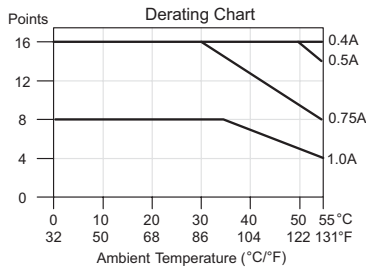
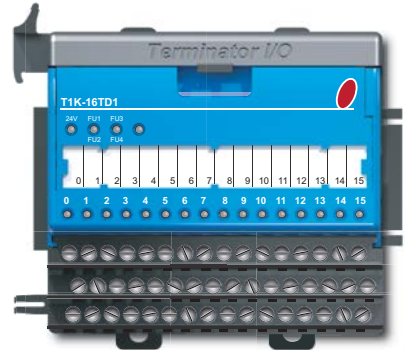

Equivalent Output Circuit

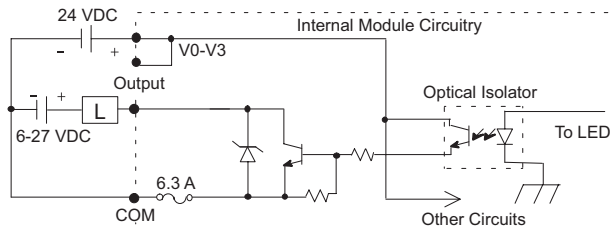

T1K-08TD2-1 - DC Output

Specifications	
Outputs Per Module	8 (source)
Commons Per Module	2 internally connected
Operating Voltage Range	12–24 VDC
Output Voltage Range	10.8 - 26.4 VDC min. / max.
Peak Voltage	50VDC
Max. Load Current	1A / pt., 4A / common
Max. Leakage Current	15 μ A @ 26.4 VDC
ON Voltage Drop	1.2 VDC @ 1.0 A
Max. Inrush Current	2A for 100ms
OFF to ON Response	< 10 μ s
ON to OFF Response	< 0.5 ms
Base Power Requirements	100mA @ 5VDC
Status Indicators	Logic Side
Error Status Indicators (LEDS)	FU1 / FU2 ON = fuse 1 or fuse 2 blown
Fuses (User Replaceable)	2, (6.3 A, 250V / common), (4 pts. / fuse)
T1K-FUSE-1	NQ3 - 6.3 SOC corp.
Weight	100g

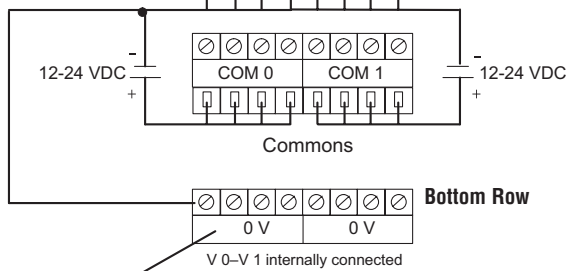
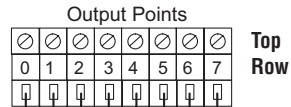
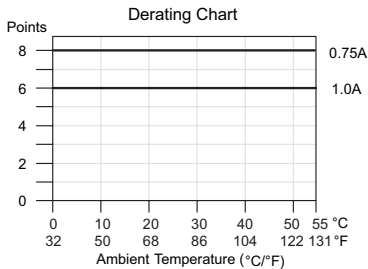
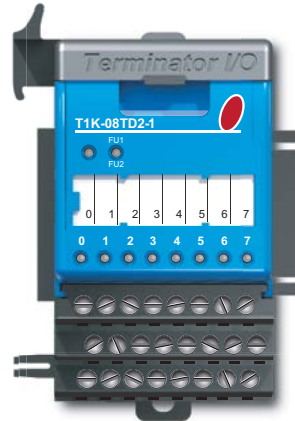

Note: Apply the 0 V label that comes with the I/O module to I/O base terminal points V 0–V 1 to properly identify the 0 VDC terminal points.

Equivalent Output Circuit

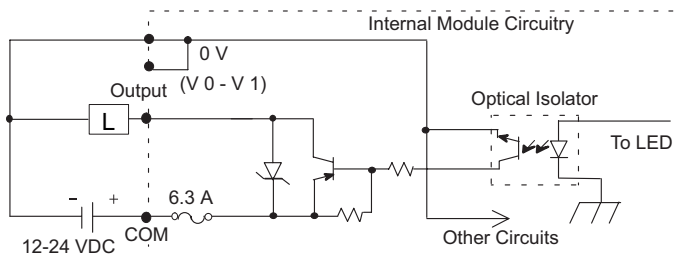

T1K-16TD2-1 - DC Output

Specifications	
Outputs Per Module	16 (source)
Commons Per Module	4 internally connected
Operating Voltage Range	12–24 VDC
Output Voltage Range	10.8–26.4 VDC min. / max.
Peak Voltage	50VDC
Max. Load Current	1A / pt., 4A / common (Subject to derating)
Max. Leakage Current	15µA @ 26.4 VDC
ON Voltage Drop	1.2 VDC @ 1.0 A
Max. Inrush Current	2A for 100ms
OFF to ON Response	<10µs
ON to OFF Response	< 0.5 ms
Base Power Requirements	200mA @ 5VDC
Status Indicators	Logic Side
Error Status Indicators (LEDs)	FU1 / FU2 ON = fuse 1 or 2 blown FU3 / FU4 ON = fuse 3 or 4 blown
Fuses (User Replaceable)	4, (6.3 A, 250 V / common), (4 pts. / fuse)
T1K-FUSE-1	NQ3 - 6.3 SOC corp.
Weight	140g

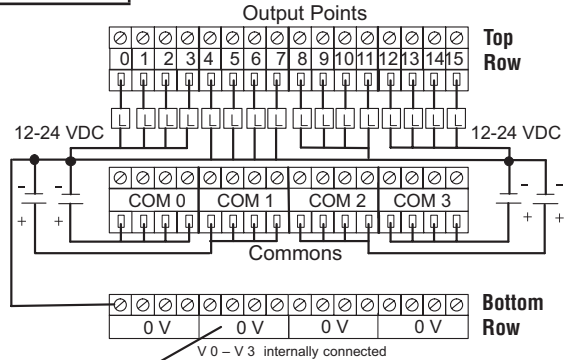
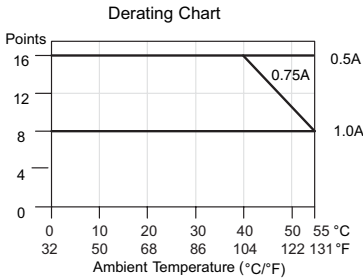

Note: Apply the 0 V label that comes with the I/O module to I/O base terminal points V 0–V 3 to properly identify the 0 VDC terminal points.

Equivalent Output Circuit

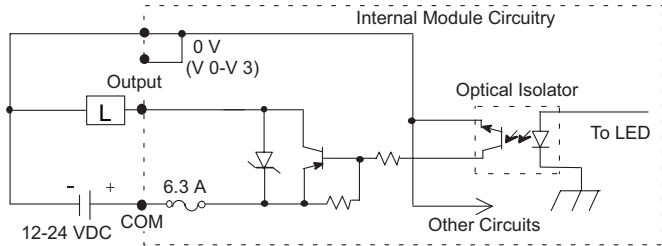

T1H-08TDS - Isolated DC Output

Specifications	
Outputs Per Module	8 (sink / source)
Commons Per Module	8 (isolated)
Operating Voltage Range	5–36 VDC
Max. Voltage	36VDC
Output Clamp Voltage	40VDC
Max. Load Current	2A / pt., 16A / module, 32°F to 140°F (0°C to 60°C)
Electronic Over Current Protection	Output trips at 6A min., 12A max.
Max. Load Voltage	36VDC
Max. Leakage Current	75µA
Max. ON State Voltage Drop	0.3 VDC @ 2.0 A, 0.15 V @ 1A
Inrush Current	5A for 20ms
OFF to ON Response	< 3µs
ON to OFF Response	< 100µs
Base Power Requirements	200mA max.
Thermal Shutdown	Between T-junction = 302°F to 374°F (150°C to 190°C)
Over Temperature Reset	Thermal shutdown temp. minus 5°F (15°C)
Status Indicators	Logic Side
Weight	93.6 g

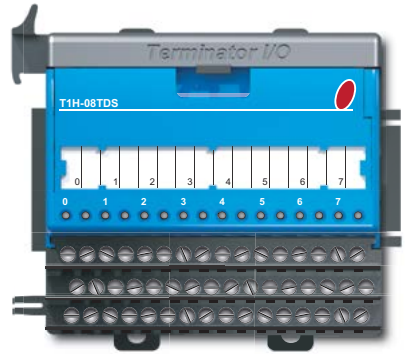

Equivalent Output Circuit

Sourcing (High Side Switching)

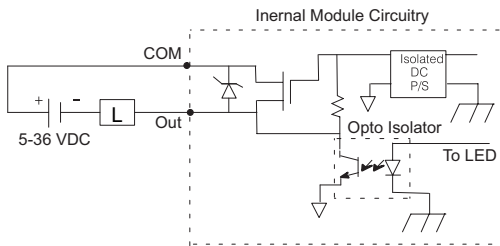

Sinking (Low Side Switching)

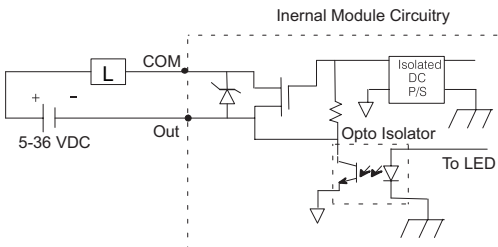

Output Points

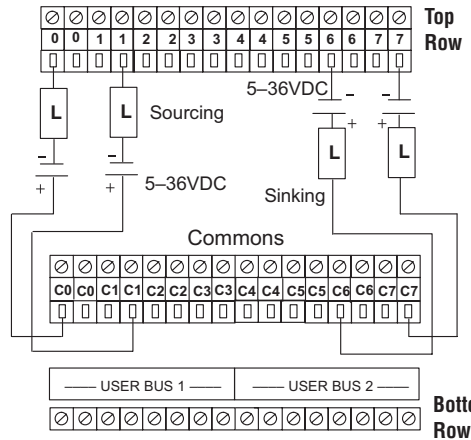

No connection: The 8 User Bus 1 terminals are bussed together. The 8 User Bus 2 terminals are also bussed together.

Note: Apply the labels that come with the I/O module to the I/O base to properly identify the terminal points.

T1K-08TA - AC Output

Specifications	
Outputs Per Module	8
Commons Per Module	2, 4 pts. / common (Isolated)
Operating Voltage Range	17-240 VAC (47-63 Hz)
Output Voltage Range	15-264 VAC (47-63 Hz) min. / max.
Max. Load Current	1A / pt., 4A / common (Subject to derating)
ON Voltage Drop	1.5 VAC @ > 50mA, 4.0 VAC @ < 50mA
Max. Leakage Current	4mA @ 264VAC
Max. Inrush Current	10A for 10ms
Min. Load	10mA
OFF to ON Response	< 1ms
ON to OFF Response	< 1ms + 1/2 cycle
Base Power Requirements	250mA @ 5 VDC
Status Indicators	Logic Side
Error Status Indicators (LEDs)	FU1 ON = fuse 1 blown FU2 ON = fuse 2 blown
Fuses (User Replaceable)	2, (10A, 250V / common), (4 pts. / fuse)
T1K-FUSE-2	5 x 20 mm type
Weight	140g

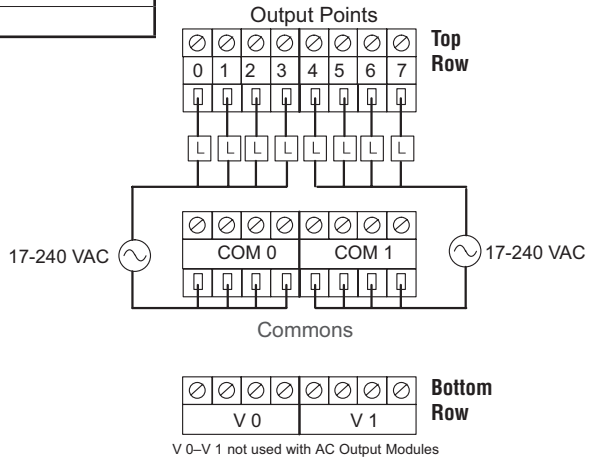
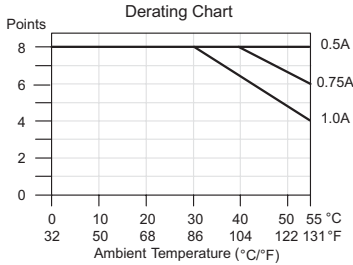
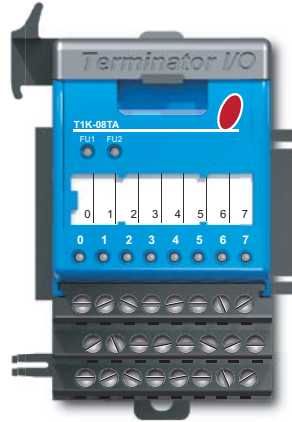

Equivalent Output Circuit

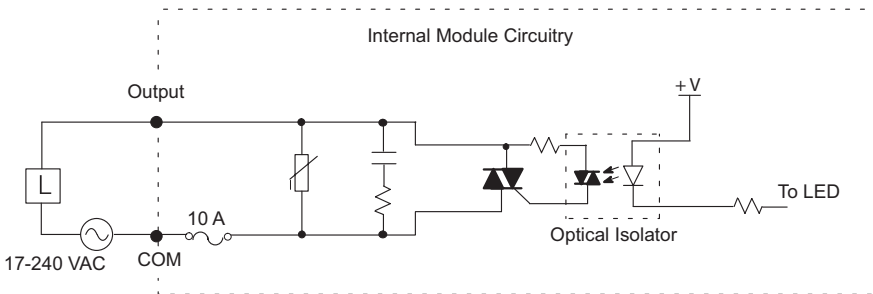

T1K-16TA - AC Output

Specifications	
Outputs Per Module	16
Commons Per Module	4, 4 pts. / common (Isolated)
Operating Voltage Range	17–240 VAC (47–63 Hz)
Output Voltage Range	15–264 VAC (47–63 Hz) min. / max.
Max. Load Current	1A / pt., 4A / common (Subject to derating)
ON Voltage Drop	1.5 VAC @ > 50mA, 4.0 VAC @ < 50mA
Max. Leakage Current	4mA @ 264VAC
Max. Inrush Current	10A for 10ms
Min. Load	10mA
OFF to ON Response	< 1ms
ON to OFF Response	< 1ms + 1/2 cycle
Base Power Requirements	450mA @ 5VDC
Status Indicators	Logic Side
Error Status Indicators (LEDs)	FU1 / FU2 ON = fuse 1 or 2 blown FU3 / FU4 ON = fuse 3 or 4 blown
Fuses (User Replaceable)	4, (10A, 250V / common), (4 pts. / fuse)
T1K-FUSE-2	5 x 20 mm type
Weight	190g

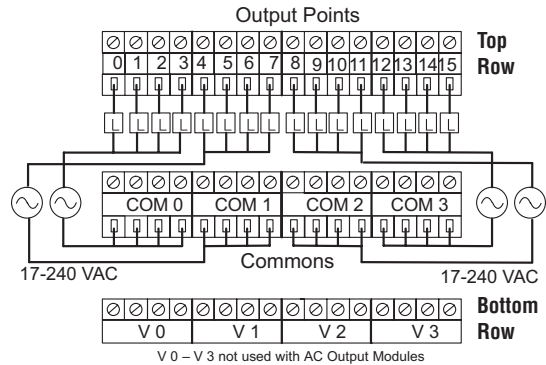
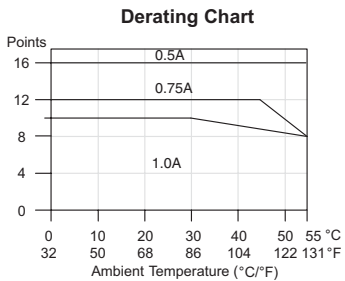
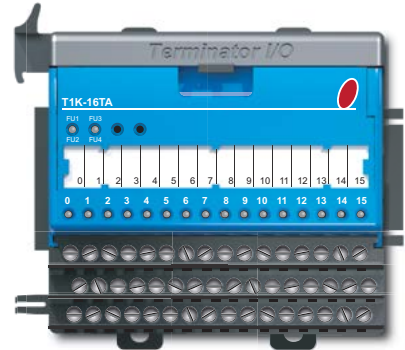

Equivalent Output Circuit

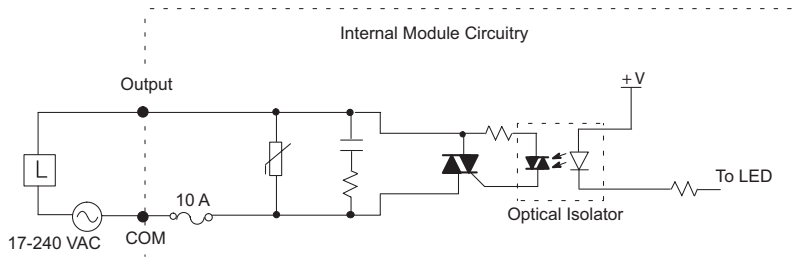

T1K-08TAS - Isolated AC Output

Specifications	
Outputs Per Module	8
Commons Per Module	8, 1 pt. / common (Isolated)
Operating Voltage Range	17–240 VAC (47–63 Hz)
Output Voltage Range	15–264 VAC (47–63 Hz) min. / max.
Max. Load Current	2A / pt. common (subject to derating)
ON Voltage Drop	1.5 VAC @ > 50mA, 4.0 VAC @ < 50mA
Max. Leakage Current	4mA @ 264VAC
Max. Inrush Current	10A for 10ms
Min. Load	10mA
OFF to ON Response	< 1ms
ON to OFF Response	< 1ms + 1/2 cycle
Base Power Requirements	300mA @ 5VDC
Status Indicators	Logic Side
Error Status Indicators (LEDs)	FU1 / FU2 ON = fuse 1 or 2 blown FU3 / FU4 ON = fuse 3 or 4 blown FU5 / FU6 ON = fuse 5 or 6 blown FU7 / FU8 ON = fuse 7 or 8 blown
Fuses (User Replaceable) T1K-FUSE-3	8 (10A, 250V / common), (1 pt. / fuse)
Weight	190g

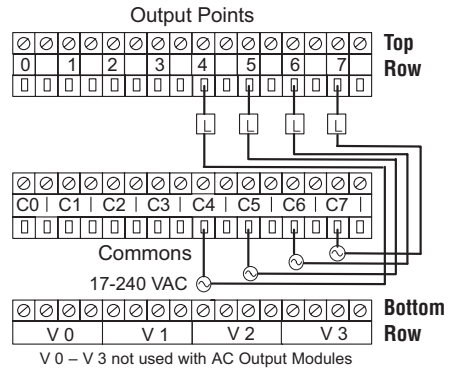
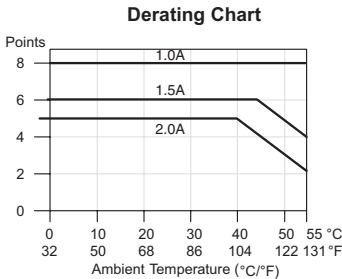
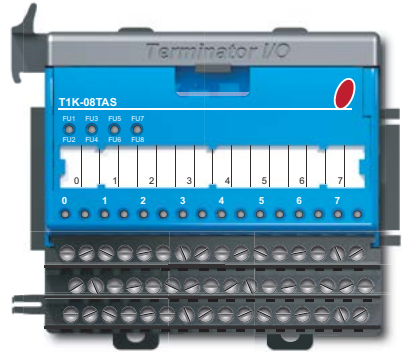

Note: Apply the labels that come with the I/O module to the I/O base to properly identify the terminal points.

Equivalent Output Circuit

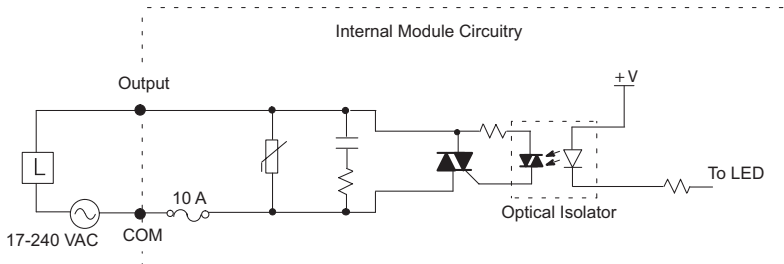

T1K-08TR - Relay Output

Specifications	
Outputs Per Module	8
Output Type	Relay Form A (SPST) normally open
Commons Per Module	2, 4 pts. / common (Isolated)
Operating Voltage Range	6–240 VAC (47–63 Hz), 6–27 VDC
Output Voltage Range	5–264 VAC (47–63 Hz) min. / max. 5–30 VDC min / max
Max. Load Current	2A / pt., 8A / common
Max. Leakage Current	0.1 mA @ 264VAC
Max. Inrush Current	6A for 10ms / pt.; 20A for 10ms / common
Min. Load	5mA @ 5VDC
OFF to ON Response	<15ms
ON to OFF Response	<10ms
Base Power Requirements	350mA @ 5VDC
Status Indicators	Logic Side
Error Status Indicators (LEDs)	FU1 ON = fuse 1 blown FU2 ON = fuse 2 blown
Fuses (User Replaceable)	2 (10A, 250V / common), (4 pts. / fuse) T1K-FUSE-2
Weight	110g



Typical Relay Life (Operations) at Room Temperature		
Voltage & Type of Load	Load Current	
	1 A	2 A
24VDC Resistive	500K	250K
24VDC Solenoid	100K	50K
110VAC Resistive	500K	250K
110VAC Resistive	200K	100K
220VAC Resistive	350K	200K
220VAC Resistive	100K	50K

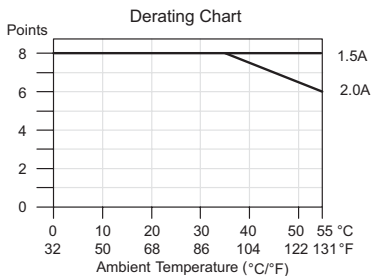
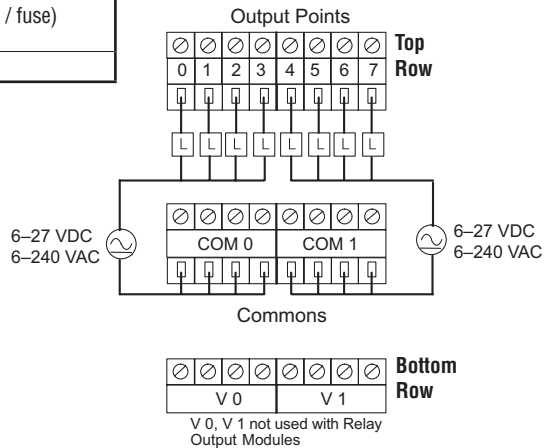

Equivalent Output Circuit

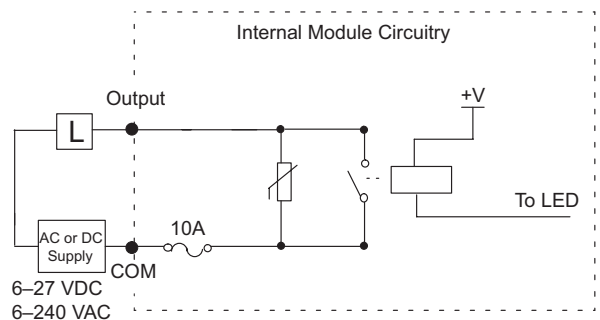

T1K-16TR - Relay Output

Specifications	
Outputs Per Module	16
Output Type	Relay Form A (SPST) normally open
Commons Per Module	4, 4pts. / common (Isolated)
Operating Voltage Range	6–240 VAC (47–63 Hz), 6–27 VDC
Output Voltage Range	5–264 VAC (47–63 Hz) min / max 5–30 VDC min / max
Max. Load Current	2A / pt., 6A / common
Max. Leakage Current	0.1 mA @ 264VAC
Max. Inrush Current	6A for 10ms / pt.; 20A for 10ms / common
Min. Load	5mA @ 5VDC
OFF to ON Response	< 15ms
ON to OFF Response	< 10ms
Base Power Requirements	700mA @ 5VDC
Status Indicators	Logic Side
Error Status Indicators (LEDs)	FU1 / FU2 ON = fuse 1 or fuse 2 blown FU3 / FU4 ON = fuse 3 or fuse 4 blown
Fuses (User Replaceable)	4 (10A, 250V / common), (4pts. / fuse) T1K-FUSE-2 5 x 20 mm type
Weight	200g

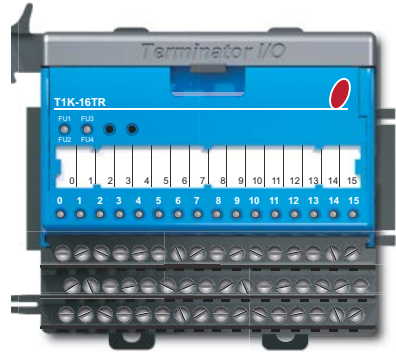

Typical Relay Life (Operations) at Room Temperature		
Voltage & Type of Load	Load Current	
	1 A	2 A
24VDC Resistive	500K	250K
24VDC Solenoid	100K	50K
110VAC Resistive	500K	250K
110VAC Resistive	200K	100K
220VAC Resistive	350K	200K
220VAC Resistive	100K	50K

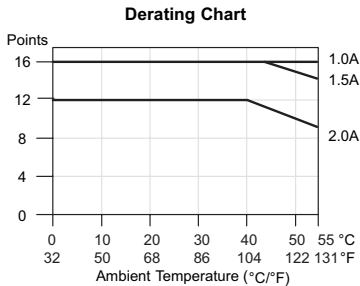
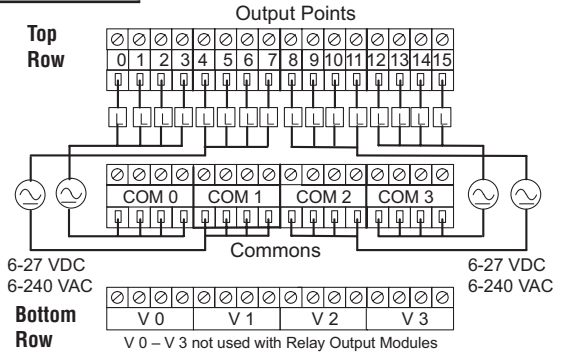

Equivalent Output Circuit

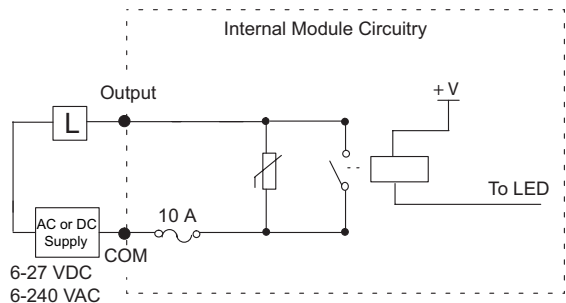

T1K-08TRS - Isolated Relay Output

Specifications	
Outputs Per Module	8
Output Type	Relay Form A (SPST) normally open
Commons Per Module	8, 1pt. / common (isolated)
Operating Voltage Range	6–240 VAC (47–63 Hz), 6–27 VDC
Output Voltage Range	5–264 VAC (47–63 Hz) min. / max. 5–30 VDC min. / max.
Max. Load Current	7A / pt. common (Subject to derating)
Max. Leakage Current	0.1 mA @ 264VAC
Max. Inrush Current	8A for 10ms
Min. Load	5mA @ 5VDC
OFF to ON Response	< 15ms
ON to OFF Response	< 10ms
Base Power Requirements	400mA @ 5VDC
Status Indicators	Logic Side
Error Status Indicators (LEDs)	FU1 / FU2 ON = fuse 1 or fuse 2 blown FU3 / FU4 ON = fuse 3 or fuse 4 blown FU5 / FU6 ON = fuse 5 or fuse 6 blown FU7 / FU8 ON = fuse 7 or fuse 8 blown
Fuses (User Replaceable) T1K-FUSE-3	8 (10A, 250V / common), (1 pt. / fuse) NQ3-10 SOC Corp.
Weight	185g

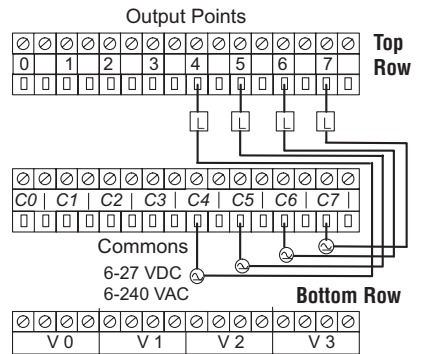
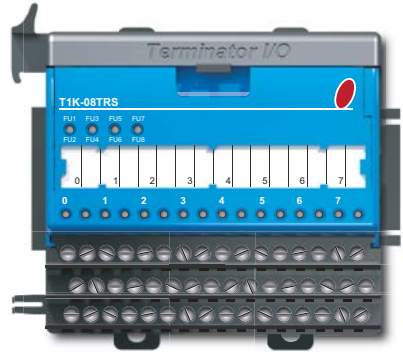

Note: V 0 – V 3 not used on Relay Output Modules

Note: Apply the labels that come with the I/O module to the I / O base to properly identify the terminal points.

Typical Relay Life (Operations) at Room Temperature				
Voltage & Type of Load	Load Current			
	1 A	2 A	5 A	7 A
24VDC Resistive	1000K	500K	200K	100K
24VDC Solenoid	300K	100K	*	*
110VAC Resistive	1000K	500K	200K	100K
110VAC Resistive	300K	100K	*	*
220VAC Resistive	500K	250K	125K	60K
220VAC Resistive	300K	100K	*	*

*Solenoid (inductive) loads > 2A cannot be used.

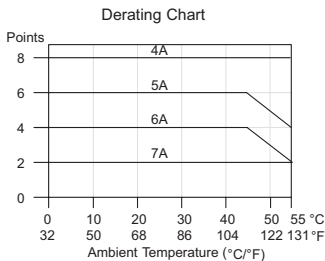

Equivalent Output Circuit

