



stay connected

ENGLISH MANUAL

for devices of the IMPACT67 EtherNet/IP series
Art.-No. 54631

This document applies to the following products:

Name	Art.-No.
IMPACT67 Pro E DIO8 IOL8 M12L 5P	54631

Document status:

Manual number	54631
Language	EN
Version	11
Date	2022-01

Murrelektronik GmbH
Falkenstraße 3
71570 Oppenweiler
GERMANY
Phone +49 7191 47-0
Fax +49 7191 47-491000
info@murrelektronik.com

NOTE

Translation of the original instructions

Table of Contents

1	Introduction	7
1.1	Service and support	7
1.2	Scope of delivery	7
1.3	Applicable documents	7
1.4	Environmentally friendly disposal	8
1.5	About this manual	9
1.5.1	Symbols	9
1.5.2	Trademarks	10
1.5.3	Specifications	10
1.5.4	Software tools	10
2	For your safety	11
2.1	General safety instructions	11
2.2	Intended purpose	12
3	Description	13
3.1	Module	13
3.1.1	Product Designation Code	14
3.1.2	Module structure	15
3.1.3	Pin assignment	16
3.1.4	Display elements	17
3.1.5	Rotary switch settings	18
3.2	IO-Link	20
3.2.1	Data storage	22
3.3	EtherNet/IP	23
3.3.1	Communication	23
3.3.2	Requested Packet Interval (RPI)	24
3.3.3	Device Level Ring (DLR)	25
3.4	Industrial Internet of Things (IIoT)	26
3.4.1	OPC UA	26
4	Technical Data	29
4.1	Electrical data	29
4.2	Environmental characteristics	32
4.3	Protection	32
4.4	Mechanical data	33
4.5	Conformity, Approvals	33
5	Mounting	34
5.1	Requirements	34
5.2	Dimensions	34
5.3	Mounting distance	35
5.4	Mounting the module	36
5.4.1	Functional ground	37
5.4.2	Addressing lid	38

6	Installation	39
6.1	Electrical Installation of the Module	39
6.1.1	Connecting sensors and actuators	40
6.1.2	Connecting the power supply	42
6.1.3	Connecting EtherNet/IP bus	43
6.2	Ensuring Tightness (IP67)	44
7	Start-up	45
7.1	Loading the EDS files	46
7.2	Adding a module to the network	48
7.3	Commissioning without EDS	53
7.3.1	Connections, parameters and properties	53
7.3.2	Connection matrix	53
7.3.3	Assemblies	54
7.3.4	Configuration values	55
8	Configuration and parameterization	60
8.1	Module configuration	60
8.2	Setting parameters	62
8.3	Requested Packet Interval (RPI) configuration	63
8.4	Device Level Ring (DLR) configuration	65
8.5	IO-Link configuration	65
8.6	Industrial Internet of Things (IIoT)	66
8.6.1	JSON	66
8.6.2	MQTT	68
8.6.3	OPC UA	70
8.6.3.1	Device identification	70
8.6.3.2	Process data	70
8.6.3.3	Configuration parameters	70
8.6.3.4	Measured values	71
8.6.3.5	Diagnostic	72
8.6.3.6	Statistics	72
9	Operation	73
9.1	LED indication	73
9.1.1	LED assignment to channel and pin	73
9.1.2	LED flashing behavior	74
9.1.3	LED indication for inputs and outputs	75
9.1.4	LED display MS and NS	77
9.1.5	LED indication for LNK/ACT	78
9.1.6	LED indication for state	79
9.1.7	LED indicator POWER US and UA	79
9.1.8	Extended LED indication	80
9.2	Diagnostics	84
9.2.1	Diagnostics structure in the control system	84
9.2.2	Diagnostics in the web server	84

9.2.3	Diagnostic value	85
9.2.3.1	Short-circuit diagnostic	85
9.2.3.2	Undervoltage diagnostic	85
9.2.3.3	Overvoltage diagnostic	85
9.2.3.4	General diagnostic	85
9.2.3.5	Buffer overflow diagnostic	85
9.2.3.6	IO-Link master diagnostic	86
9.2.3.7	IO-Link device diagnostic	87
9.3	Acyclic IO-Link device access	89
9.3.1	Reading an IO-Link device index	89
9.3.2	Writing an IO-Link device index	90
9.3.3	CIP status codes	91
<hr/>		
10	Web server	92
10.1	Starting the web server	93
10.2	Menu bar	94
10.2.1	STATUS menu	94
10.2.2	PARAMETERS menu	97
10.2.3	DIAGNOSTICS menu	99
10.2.4	MAINTENANCE menu	99
10.3	IO-Link Master Port	100
10.3.1	STATUS menu	100
10.3.2	INFORMATION menu	102
10.3.3	CONFIGURATION menu	103
10.3.4	IO-LINK PARAMETER menu	104
10.3.5	PROCESS DATA menu	104
10.4	Settings / Maintenance	105
10.4.1	DEVICE CONFIGURATION menu	105
10.4.2	MAINTENANCE INFORMATION menu	105
10.4.3	FIRMWARE menu	106
10.4.4	FACTORY RESET menu	106
10.5	User Administration	107
10.6	Digital IO Channels / IO Overview	107
10.6.1	Input data	107
10.6.2	Output data	108
<hr/>		
11	Maintenance and cleaning	109
<hr/>		
12	Appendix	110
12.1	Supported EtherNet/IP objects	110
12.1.1	Standard object class	110
12.1.1.1	Identity Object (Class Code: 0x01)	110
12.1.1.2	Message Router Object (Class Code: 0x02)	111
12.1.1.3	Assembly Object (Class Code: 0x04)	111
12.1.1.4	Connection Manager Object (Class Code: 0x06)	112
12.1.1.5	Device Level Ring (DLR) Object (Class Code: 0x47)	112
12.1.1.6	Quality of Service Object (Class Code: 0x48)	113

12.1.1.7	TCP/IP Interface Object (Class Code: 0xF5)	114
12.1.1.8	EtherNet/IP Link Object (Class Code: 0xF6)	115
12.1.2	Vendor Specific Objects	118
12.1.2.1	IO-Link Device Parameter Object (Class Code 0x83)	118
12.2	Explanation of the process data	119
12.2.1	Digital Input	119
12.2.2	DI Qualifier	119
12.2.3	DO Qualifier	120
12.2.4	System Status	120
12.2.5	IO-Link Port X Status	121
12.2.6	Diagnostic Buffer	121
12.2.7	Digital Output	121
12.3	Accessories	122
12.3.1	System components	122
12.3.2	Tools	122
12.4	Glossary	123
<hr/>		
13	Legal notes	124

1 Introduction

Function of this document

This document instructs the technical personnel of the machine manufacturer or machine operator on the safe use of the devices.

It does not include instructions on the safe use of the machine in which the devices are or will be integrated. Information on this is contained in the operating instructions for the machine.

- ➔ Read this chapter carefully before you start working with the documentation or the device.
- ➔ Read the documentation carefully before starting up the device.
- ➔ Store the manual in a place that is accessible to all users at all times for the entire service life of the device.

You will need general knowledge about automation engineering in order to understand this manual. In addition, planning and using automation systems requires technical knowledge which is not contained in this manual.

1.1 Service and support

Sales and distribution

Our sales employees in the indoor and outdoor service and our technicians will support you at any time.

Customer Service Center (CSC)

Our staff of the Customer Service Center will help you with all questions concerning installation and start-up. They support you, for example, if you have problems with combining hardware and software products from different manufacturers with Murrelektronik products.

A number of support tools and measurement facilities are available for field bus systems and EMC interferences.

Please do not hesitate to call us at +49 (0) 7191 47-2050 or send an e-mail to support@murrelektronik.com

Service addresses

Murrelektronik GmbH has a policy of customer proximity, both at national and international level. Please visit our website to find your contact person: www.murrelektronik.com

1.2 Scope of delivery

The scope of delivery includes:

- 1x IMPACT67 module
- 1x Operating instructions – multilingual
- 15x Designation label

1.3 Applicable documents

Other applicable documents

Document	Art. No.	Location
Operating Instructions	54631	Included in the scope of delivery or downloadable from http://shop.murrelektronik.com
Product data		

1.4 Environmentally friendly disposal

Comply with country-specific waste disposal regulations!

- Always dispose of scrap devices in compliance with the applicable country-specific regulations on waste disposal (e.g., the European Waste Code 16 02 14).

Scrap materials may only be sorted by qualified persons!

- Proceed with caution when dismantling the device since you could injure yourself.
- Sort the separated components into the correct recycling line.



Disposal

The product can be returned to Murrelektronik GmbH free of charge for disposal. The same is true for the original packaging and any batteries or power packs. Any units that have been contaminated with hazardous substances will not be accepted for repair or disposal.

Returns

- Label the product and the packaging with **"For disposal"**.
- Package the product.
- Send the package to:

Murrelektronik GmbH
Falkenstraße 3
71570 Oppenweiler / Germany

We will make sure that the items are disposed of in accordance with German legislation. The most recent owner is responsible for transport to the return point until items arrive at their destination.

1.5 About this manual

1.5.1 Symbols

This document includes information and notes that must be observed for your own safety and to avoid injuries and equipment damage. They are marked as follows:



DANGER!

Immediate danger.

→ Failure to observe this warning involves an imminent risk of death or serious injuries.



WARNING!

Possible danger.

→ Failure to observe this warning can lead to death or serious injuries.



CAUTION!

Low-risk danger.

→ Failure to observe this warning can lead to mild or moderate injuries.

NOTICE

Possible material damage.

→ Failure to observe the warning may cause damage to the device and/or the system.



NOTE

Other technical information and notes of Murrelektronik GmbH.



RECOMMENDATION

Notes with this symbol are recommendations of Murrelektronik GmbH.



PRODUCTS AND ACCESSORIES

This symbol indicates accessories or product recommendations.

Instruction for use

→ An arrow marks instructions.

→ Read and observe the instructions.

1 | If they are numbered, it is absolutely necessary to follow them in the correct order.

2 | Read and observe the instructions.

1.5.2 Trademarks

Trademarks of the following companies and institutions are used in this documentation:

EtherNet/IP	ODVA, Inc.
IO-Link	c/o PROFIBUS Nutzerorganisation e.V. (PNO)
STUDIO 5000 LOGIX DESIGNER	Rockwell Automation Inc.

1.5.3 Specifications

Specification	Link
EtherNet/IP Specification	http://www.odva.org

Specification	Link
IO-Link Version 1.1.2 dated 2013-07	www.io-link.com



The features of IO-Link specification version 1.1.3 are also supported.

1.5.4 Software tools

Software

Software used
Studio5000, Rockwell Automation Inc
Murrelektronik IO-Link Device Tool

2 For your safety

- Read this chapter carefully.
- Only after that you may work with the fieldbus module.

2.1 General safety instructions



DANGER!

High electrical voltage in the machine/system.

Death or severe injuries resulting from electric shock

- When working on the machine/the modules, comply with the five safety rules of electrical engineering.

Protection of persons and material assets

- According to DIN VDE 0105-100 - Operation of electrical systems - Part 100:
General definitions

The five safety rules

Protect against high electrical voltage

- 1 | Disconnect
- 2 | Secure against switching on again
- 3 | Make sure that there is no voltage on all poles.
- 4 | Ground and short-circuit
- 5 | Cover or block off neighboring parts that are live or energized

Qualified personnel

Only qualified personnel instructed in safety are allowed to install the module and to put it into operation.

They are qualified if they meet the following requirements:

- They have undergone suitable electrical engineering training,
- They were trained by the machine operator to operate the machine and instructed on the related safety regulations,
- They have access to the Operating Instructions and this manual
- They are familiar with the safety standards which are common practice in automation engineering
- They are familiar with the basic and technical standards related to the specific application

Using the unit

- Comply with all safety and accident prevention regulations when conducting project engineering, installation, commissioning, operation, and testing of the device.

- Check material resistance if aggressive media are used.



NOTE

Work on the hardware and software may only be performed by qualified personnel of Murrelektronik GmbH, with the exception of firmware updates.



NOTE

Use only a power supply unit that allows max. 60 V DC or 25 V AC under single-fault conditions. The power supply must comply with SELV or PELV.

**CAUTION!****Hot surface!**

Minor injuries and damage to devices caused by contact with the surface.

- Wear thermally suitable gloves.
- Use thermally suitable connecting cables only.

Protective measures by the machine operator

- Follow the instructions in this manual.
- Pay attention to the specifications and the operating instructions of all connected components.

2.2 Intended purpose

IMPACT67 is a decentralized device. It can be used in harsh industrial environments up to degree of protection IP67.

Operation of the device in accordance with its designated use and the degree of protection IP67 are only guaranteed if open male and female connectors are closed using screw plugs.

Designated use also includes EMC-compliant electrical installation. The device is designated for use in industrial environments. Radio interference may occur if used in domestic or mixed environments.

- If the device is used in domestic or mixed environments, the applicable standards must be observed.

Warnings

- Do **not** alter the design, engineering, or electrical features of the module.
- Do **not** use the module outside the applications described in this manual, the Technical Data or in the operating instructions.
- Do **not** use the module as a safety-related device. It does not meet the relevant standards. Safety functions of the system are not ensured!
- Do **not** use the Off state of the module outputs for safety-related requirements of the system/machine!
- Do **not** use the module outdoors or for continuous operation in liquids.
- Do **not** clean the module with a high-pressure cleaner.
- Do **not** use the module as a climbing aid.

Warranty and liability claims

Warranty and liability claims become void if

- the product is not used according to its designated use,
- damage is caused because the manual and the operating instructions have not been observed,
- the personnel was/is not qualified.

3 Description

3.1 Module

The **IMPACT67** is a fully encapsulated fieldbus module in a plastic case. It is particularly robust and designed for use in rough environments.

Property	Description
Robust	Versatile applications under very high loads due to: <ul style="list-style-type: none"> ■ robust plastic case, ■ No formation of water of condensation due to fully encapsulated case.
Vibration-proof	Safety function also guaranteed when subjected to continuous vibration
Resistant	Long life due to acid and alkali resistant plastic.
Tight	Tight up to degree of protection IP67 (EN 60529)



3.1.1 Product Designation Code

IMPACT67	Product family
E	Function <ul style="list-style-type: none">■ EtherNet/IP
DIO8	Digital inputs and outputs <ul style="list-style-type: none">■ D = Digital■ I = Input■ O = Output Number of channels <ul style="list-style-type: none">■ 8 = 8 channels (pin 2)
IOL8	IOL = IO-Link master Number of channels <ul style="list-style-type: none">■ 8 = 8 channels (pin 4)
M12L 5P	POWER connection (power supply) <ul style="list-style-type: none">■ M12 = Size■ L = Coded■ 5P = 5-pin version with FE (Functional ground)

3.1.2 Module structure

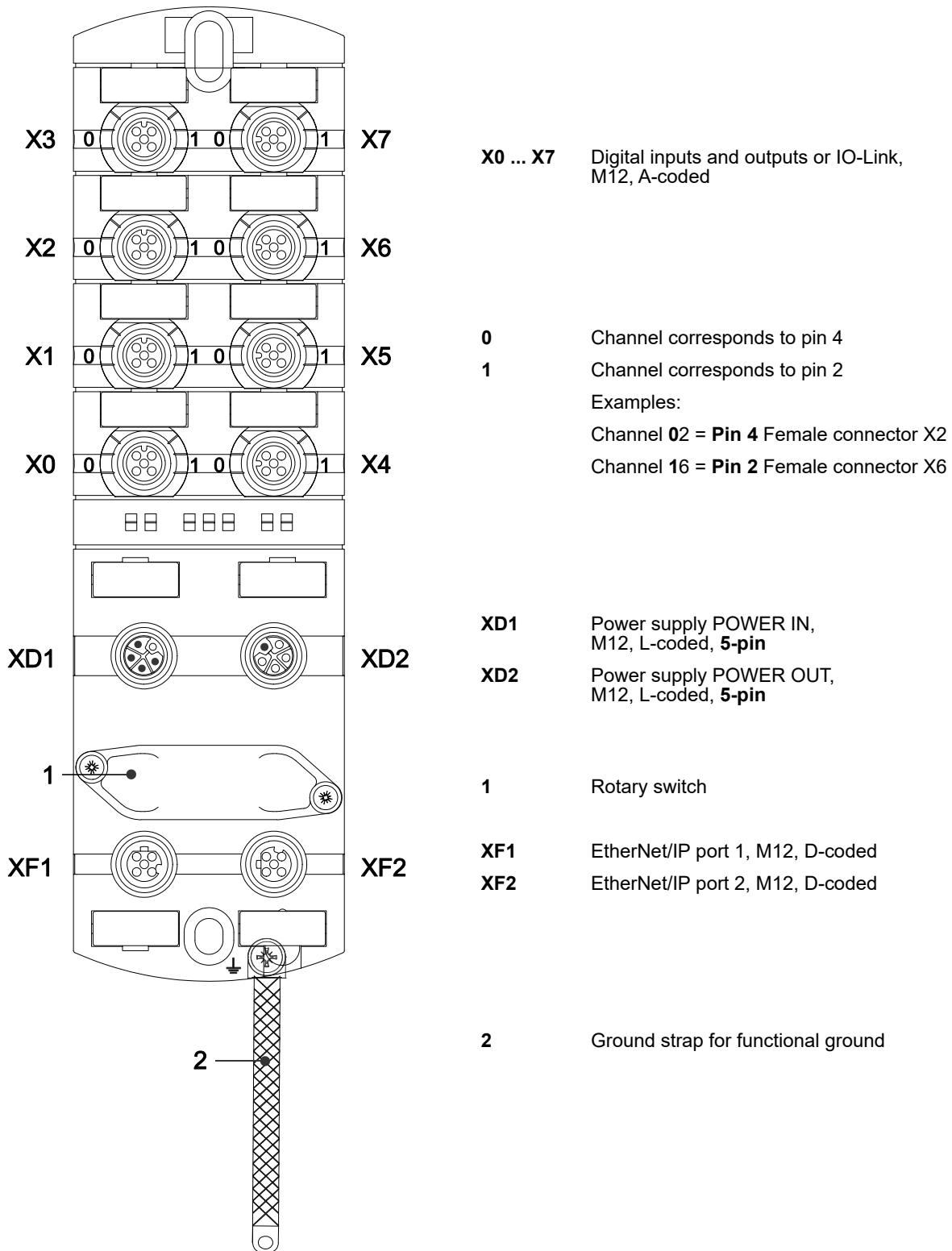
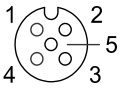

Fig. 3-1: Module structure

3.1.3 Pin assignment

M12 female connector A-coded

X0 ... X7		
	Pin 1	24 V $\overline{\text{---}}$
	Pin 2	DI/DO
	Pin 3	0 V
	Pin 4	DI/DO/IO-Link
	Pin 5	0 V

M12 male/female connector L-coded POWER IN/OUT

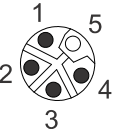
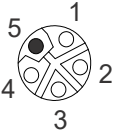
XD1		XD2	
	Pin 1	24 V $\overline{\text{---}}$ US	
	Pin 2	0 V UA	
	Pin 3	0 V US	
	Pin 4	24 V $\overline{\text{---}}$ UA	
	Pin 5	\perp	

M12 female connector D-coded Port 1 / Port 2

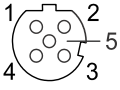
XF1 / XF2		
	Pin 1	TD +
	Pin 2	RD +
	Pin 3	TD -
	Pin 4	RD -
	Pin 5	n.c.

3.1.4 Display elements

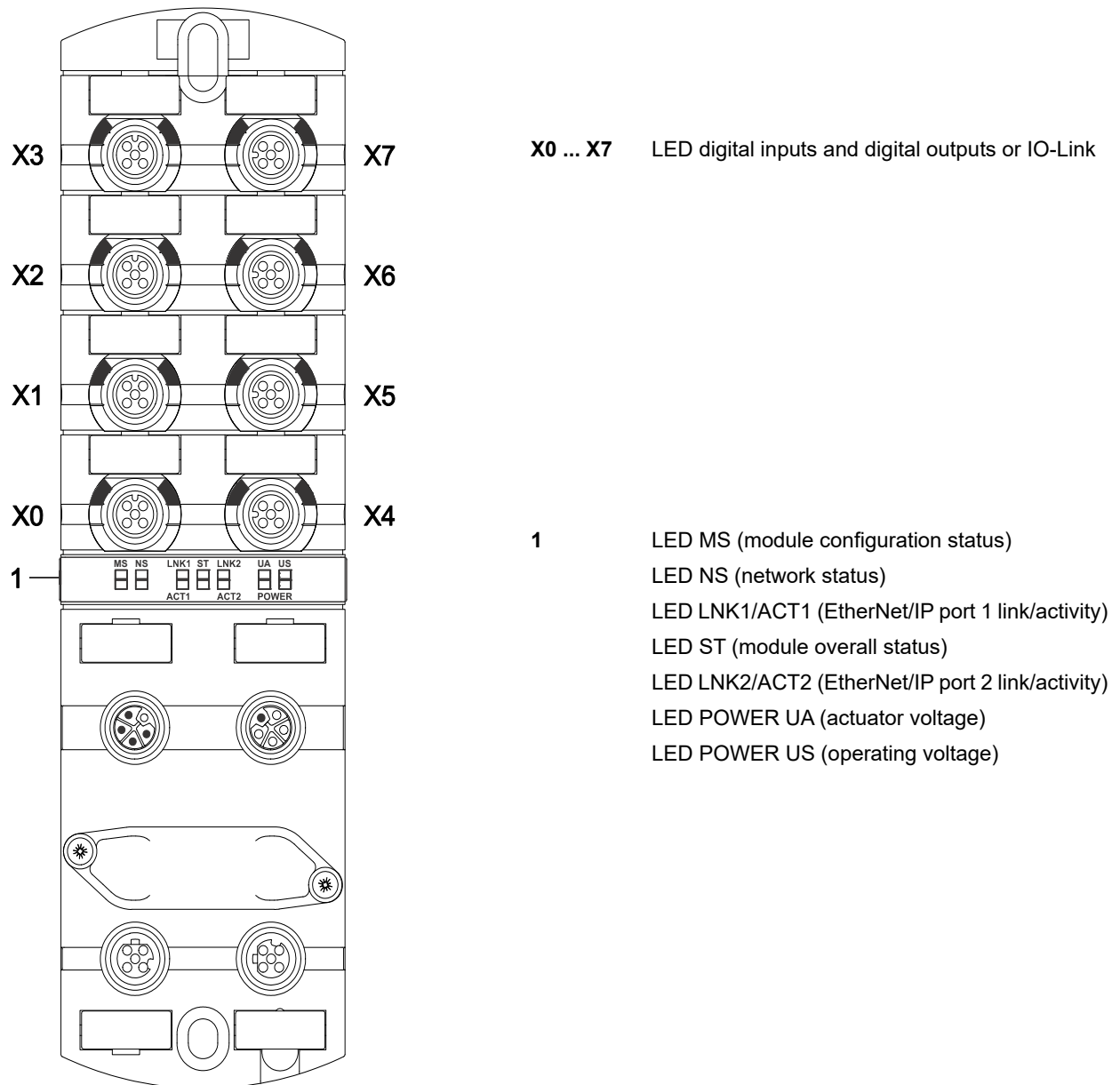

Fig. 3-2: Display elements

3.1.5 Rotary switch settings



NOTE

Delivery state:

The rotary switches are set to **000**, DHCP enabled.



NOTE

An unambiguous and unique IP address must be assigned to each user in the network.

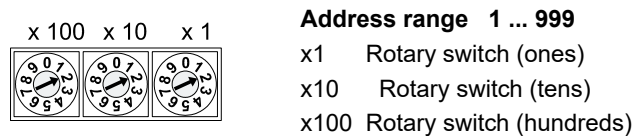

Tab. 3-1: Rotary switch for addressing

Position/ Range	Web server	JSON	OPC UA	MQTT	Description	
0	-	-	-	-	Out of the box: DHCP	Previously saved interface configuration: Saved configuration is applied.
1 ... 254	-	-	-	-	Last octet	Setting the fourth octet of the IP address with the rotary switch value. Default setting: 192.168.1.xxx
255	-	-	-	-	Static IP address	The last saved IP address is active.
256 ... 910	-	-	-	-	Reserviert	
911	disabled	disabled	disabled	disabled	Secure Mode	Fieldbus communication in normal operation
912	-	disabled	disabled	disabled	IIoT Mode disabled	
913	disabled	-	-	-	Web server disabled	
914	enabled	enabled	enabled	enabled	Enabled all IIoT protocols and the web server.	
915-978	-	-	-	-	Reserved	
979	enabled	enabled	enabled	enabled	Reset to factory settings	Action sequence only for this rotary switch position: 1 Disconnect module from power supply. 2 Set switch position 979. 3 Supply module with power. 4 Wait for at least 2 minutes. 5 Disconnect module from power. 6 Switch position to 000 or any other desired position. 7 Supply module with power.
980-999	-	-	-	-	Reserved	

Tab. 3-2: Setting the IP address on the rotary switches



NOTE

Reserved switch positions have no fieldbus communication, see 9.1 "LED indication".



NOTE

The saved default IP address is 192.168.1.6.



NOTE

The IP address parameters are stored for all switch settings. This must be taken into account in particular with the switch setting **0**.

Setting an address

- 1 | Remove the rotary switch cover.
- 2 | Set the three rotary switches.
- 3 | Carefully replace the rotary switch cover.



The tightening torques can be found in chapter 5.4.2 "Addressing lid"

3.2 IO-Link

IO-Link is a standardized protocol that enables connection of intelligent devices (sensors and actuators) to an automation system.

Communication takes place between an IO-Link master and one or more IO-Link devices. A master module has one or more ports and one device can be connected to each port. IO-Link is a point-to-point communication system and is not a fieldbus.

The IO-Link master module is the interface between the controller and the IO-Link system.

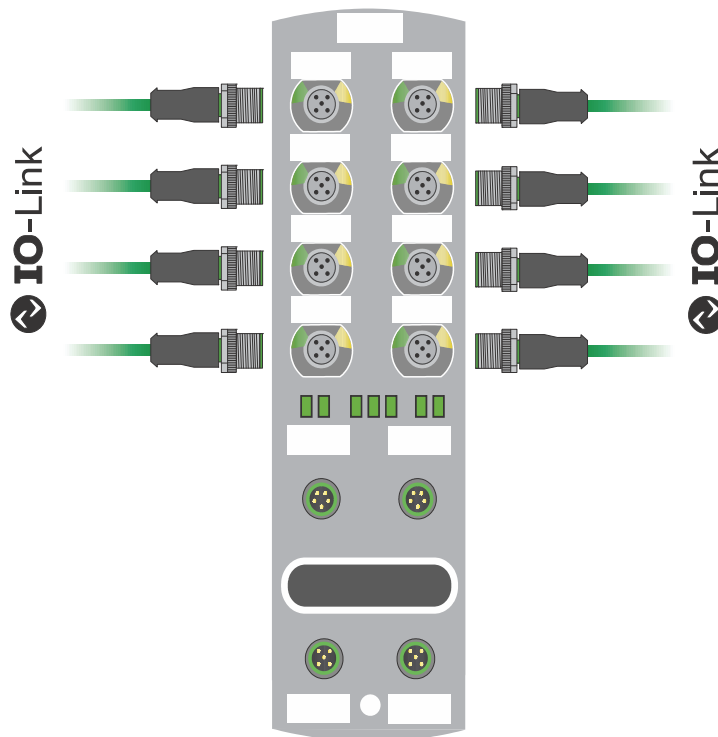

Fig. 3-3: IO-Link

IO-Link mode (IOL)

IO-Link communication (C/Q) is activated on pin 4 and an IOL device can thus be connected.

IO-Link CALL

The acyclic data can be used to write the device parameters from an IO-Link device or to read parameters, measured values and diagnostic data from an IO-Link device.

The following tasks can be performed:

- Parameterization/configuration of an IO-Link device when the system is running.
- Diagnostic of an IO-Link device by reading diagnostic parameters.
- Execution of IO-Link port functions.
- Back-up/recovery of IO-Link device parameters.

The data on the IO-Link device is uniquely addressed with index and sub-index.

This data can be accessed with the so-called IOL CALL. This is usually provided as a data handling block by the PLC manufacturer.

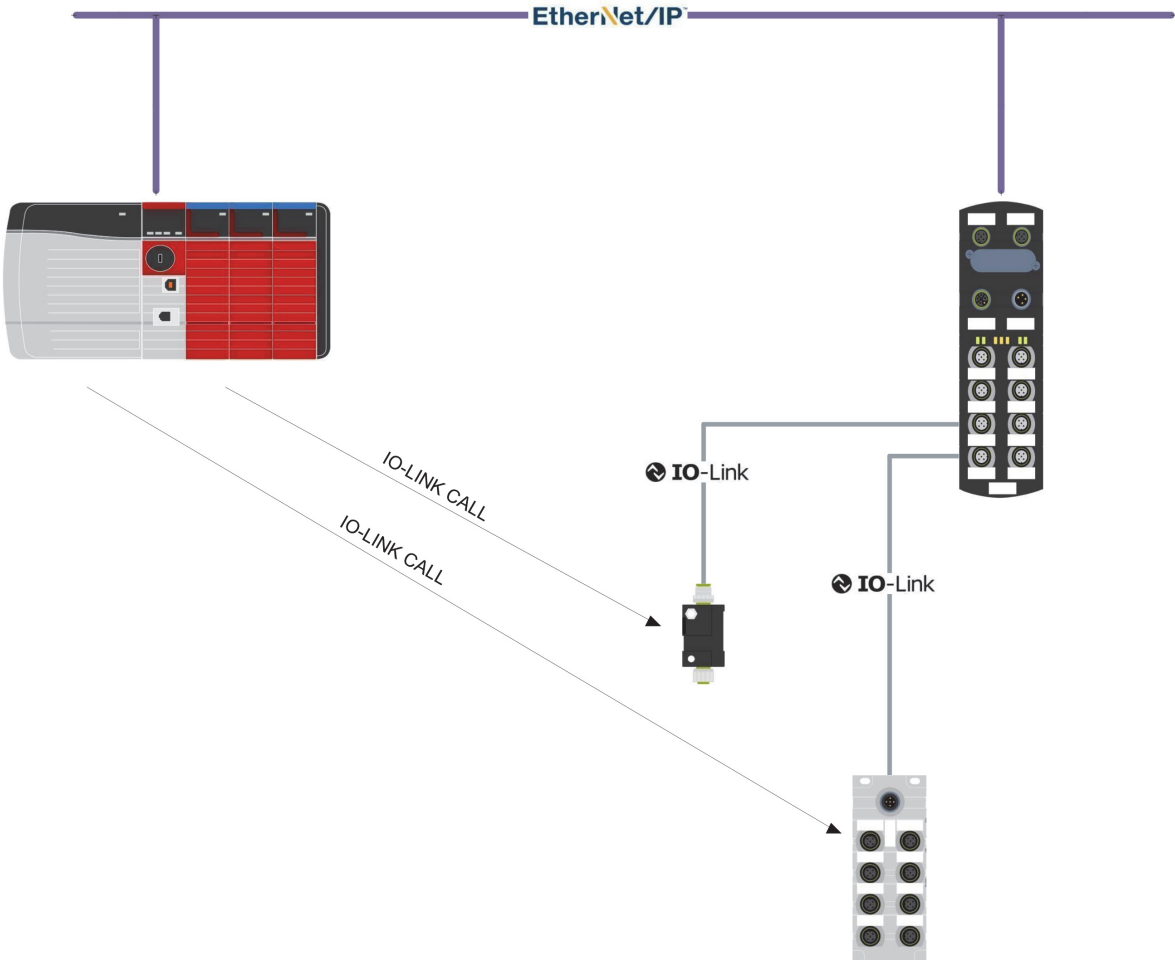

Fig. 3-4: IO-Link CALL



For further information, refer to chap. 8.5 "IO-Link configuration"

3.2.1 Data storage



NOTE

Data storage is only available for IO-Link devices that comply with IO-Link version V1.1 and higher.

- Data storage offers scope for replacing IO-Link devices without reconfiguration.
- The IO-Link master and the IO-Link device save the set device parameters of the previous parameterization.
- In data storage, the parameter data storage facilities of the IO-Link master and IO-Link device are synchronized.
- Following the replacement of a device, the master writes the saved device parameters to the new device whenever data storage is enabled in the IO-Link master.
The application can be restarted without reparameterization.
- After having replaced the IO-Link master, the master reads the IO-Link device parameters and stores them. For this, the data storage option “Save and restore” must be active.
The application can be restarted without reparameterization.
- To use data storage, the vendor ID and the device ID of the connected IO-Link device must be entered additionally for each IO-Link master port in the validation settings.
The IO-Link port mode must be set to “Manual”.
- To store the modified IO-Link device parameters again in the master, device parameterization must be done via block parameterization.

After this, the device sends an upload request to the master.

Block parameterization can be carried out via the IO-Link device tool in the “Parameter” window and with the “Block Write Mode”.

Optionally, block parameterization can also be done via the web server or a PLC block,
e.g. Siemens IOL_Call.

In this case, block parameterization must always be completed with the command “Parameter Download Store” ISDU index 0x02 subindex 0 value 05.

CMD	P.OP	102.82103	WRITE_INDEX	2	✓	COM2	Standard Command=[Parameter Download Start]	03
	P.OP	102.90306	WRITE_INDEX	74	✓	COM2		01
	P.OP	102.96578	WRITE_INDEX	161	✓	COM2		01
	P.OP	103.02850	WRITE_SUBINDEX	75	1	✓	COM2	01
	P.OP	103.09122	WRITE_SUBINDEX	86	1	✓	COM2	00 1E
	P.OP	103.16843	WRITE_SUBINDEX	80	1	✓	COM2	00 1E
	P.OP	103.24563	WRITE_SUBINDEX	81	1	✓	COM2	00 32
	EV	P.OP	103.70399	SINGLESHOT		COM2	0xFF91: DS Upload Request	
CMD	P.OP	103.32285	WRITE_INDEX	2	✓	COM2	Standard Command=[Parameter Download Store]	05

- In the validation/backup mode “no Device check”, the saved device parameter content in the IO-Link master is deleted.

3.3 EtherNet/IP

3.3.1 Communication

EtherNet/IP is based on a generator/receiver communication model for which the multicast Ethernet communication enables fast "Report by exception" responses.

The connection to the control scanner can only be established in an EtherNet/IP network via 10/100MBit/s Ethernet switches.



The maximum permissible cable length to the end point without any auxiliary devices is 100 m.

A 2-port switch is integrated into the fieldbus device. This switch sends multicast messages to all switch ports and behaves in this case like a hub. When Unmanaged Switches are used, more multicast users (EtherNet/IP users) are added to the system, resulting in more multicast traffic for the users. Thus, a higher amount of bandwidth is used in the system which results in longer response times as each user must evaluate messages that are not addressed to the user.

Excessive network traffic may result in missed messages and RPI response delays which may interrupt communication.

It is therefore recommended to split the entire network into several segments by means of several switches. By choosing suitable RPI times and switches, high-speed networks can be decoupled from non-time-critical systems.



A Managed switch should be considered for network segments that include traffic unrelated to the IO-Link segment.

Managed switches are recommended for high-speed control systems. To manage the multicast traffic, the switch must support the IGMP Snooping function (Internet Group Management Protocol). For the connection of a control system to a large plant or company network, consider using a virtual LAN on a switch, or a router.

Unicast connections

The device is able to establish data connections using Unicast connections. Unicast connections may result in reduced traffic on the network. Please select the best type of connection for your application.

3.3.2 Requested Packet Interval (RPI)

When setting up an EtherNet/IP system, the RPI value must be carefully set in the scanner.

According to the manufacturer's version, this value is in the range between 1 ms and several hundred ms.

The RPI value determines the speed at which the scanner sends EtherNet/IP messages (packets).

It also determines the maximum speed at which the bus node sends messages.

The value that is set in the scanner is transmitted to the device as soon as the connection is established so that the system uses the same time base.

The RPI value can be used not only to set the speed but also to set the speed at which the scanner expects timely reception.

If the selected RPI time is too short, a higher network load is automatically generated.

Due to the higher network load, the system must spend more time to process the queries accordingly.

This is also applicable to the messages which are not addressed directly to the device since they must be accepted and rejected anyway.

This results in an overload situation in which the device is no longer able to execute the internal processes and adhere to the required RPI time.

If the reception of the telegram exceeds the set RPI time by a factor of 4, the control interrupts the I/O communication and switches into an error state.

Please observe:

- a | Configurations which require RPI times shorter than 10 ms must be tested in advance for correct operation.
- b | The minimum supported RPI time is 1 ms!



For further information, refer to chap. 8.3 "Requested Packet Interval (RPI) configuration"

3.3.3 Device Level Ring (DLR)

Device Level Ring (DLR)

Device Level Ring (DLR) is a protocol which allows media redundancy in a ring topology, e.g. for EtherNet/IP™.

A ring network consists of at least one ring supervisor and any desired number of devices.

To build up the topology and to detect cable breaks inside the ring, there are two different methods:

- a | Beacon-based
- b | Announce-based

Devices which support DLR must have implemented the DLR object (0x47) which details configuration and diagnostic.



The modules described in this manual support the beacon-based DLR technology.

The described modules do **not** support the ring supervisor function and can not be used as ring supervisor.



For further information, refer to chap. 8.4 "Device Level Ring (DLR) configuration"

3.4 Industrial Internet of Things (IIoT)

3.4.1 OPC UA

The device has an OPC UA server. An OPC UA client can establish a connection to the module and access the following parameters:

- device identification,
- configuration parameters,
- process data,
- measured values,
- diagnostic information,
- statistical information, etc.

The OPC UA client establishes a connection via the following URL:

opc.tcp://IP address:4840



The module's ***IP address*** is used.

The client can access the device parameters anonymously (read access) or with user name/password (read and write access). The user name and the password are set with the Field IO Webserver.

The following figure shows an excerpt of the module's information model.

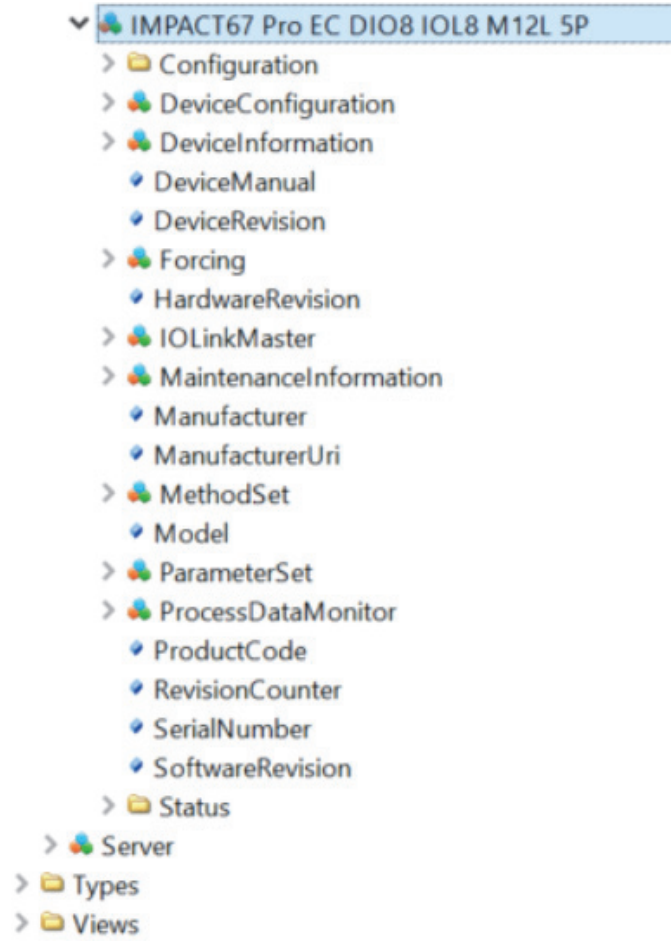

Fig. 3-5: OPC UA server - Information model of the device

The following figure shows an excerpt of an IO-Link port's information model.

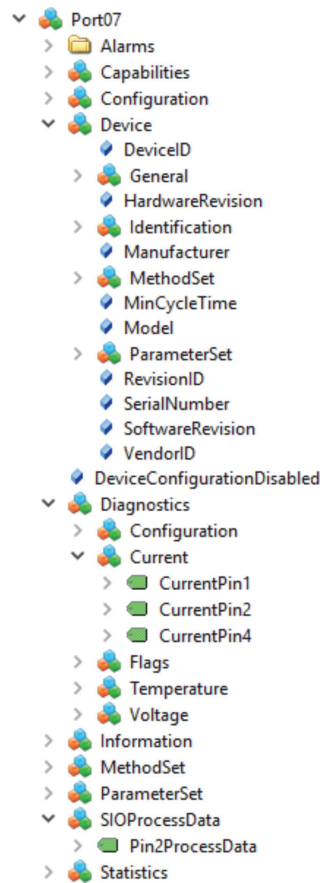

Fig. 3-6: OPC UA server - Information model of a port



For further information, refer to chap. 8.6.3 "OPC UA"

4 Technical Data

4.1 Electrical data

IIoT functions		
Web interface	http://	Yes
OPC UA	For IO-Link according to Companion Specification Release 1.0 and Murrelektronik IO-Link diagnostic information model	Yes
OPC UA	Transport	UA TCP, UA Secure Conversation, UA Binary Encoding
OPC UA	Minimum release interval	100 ms
OPC UA	Maximum number of sessions/clients	5
JSON	JSON integration for IO-Link V1.0.0	Yes, via REST API and MQTT
Energy monitoring	Current and voltage	Yes
Temperature monitoring		Yes

Bus data		
Fieldbus protocol		EtherNet/IP
Ethernet		10/100 Mbit/s
Addressing		BOOTP, DHCP, WebUI, Rotary encoder switch
Connection types		Exclusive Owner, Listen Only, Input Only
Device Level Ring (DLR)		Beacon-based
Connector		M12, 4-pin, D-coded

IO-Link		
IO-Link devices operating voltage		24 V \overline{DC}
IO-Link devices voltage range		20 ... 30 V \overline{DC}
Transfer rate		COM1 / COM2 / COM3
Standardized Master Interface (SMI)		According to IO-Link specification V1.1.3
Transfer rate recognition		Automatic

Supply		
Operating voltage US		24 V \overline{DC}
Voltage range US		18 ... 30 V \overline{DC}
	When using IO-Link	20.3 ... 30 V \overline{DC}
Operating voltage UA		24 V \overline{DC}
Voltage range UA		18 ... 30 V \overline{DC}
Sensor current US	≤ 40 °C (see Derating)	≤ 16 A
Actuator current UA	≤ 40 °C (see Derating)	≤ 16 A
Current consumption	At idle	≤ 0.18 A
Protection against reverse polarization for US and UA		Yes
Reverse polarity protection		Yes
Connection		M12, 5-pin, L-coded
Conductor cross-section	Current per supply ≤ 12 A	$\geq 1,5$ mm ²
	Current per supply > 12 A	$\geq 2,5$ mm ²

Input (DI)		
Sensor power supply	Per port, ≤40 °C (see Derating)	≤2 A load Automatic start
Total current sensor supply	≤40 °C (see Derating)	≤10 A
Filter time		0 ... 15 ms + tcycle, adjustable
Delay time for signal change		2 ... 5 ms
Input characteristic	EN 61131-2	Type 1 + Type 3
Short-circuit protection, sensor supply		MOSFET with current measurement
Connection		M12, 5-pin, A-coded
Conductor cross-section		≤0.75 mm ²
Conductor length		≤30 m
Total current	Per port	≤4 A

Output (DO)		
Output current DO (UA)	Per channel, ≤40 °C (see Derating)	≤2 A
Total current outputs	≤40 °C (see Derating)	≤16 A
Frequency		≤50 Hz
Short-circuit protection actuator		MOSFET with current measurement
Connection		M12, 5-pin, A-coded
Conductor cross-section		≤0.75 mm ²
Conductor length		≤30 m
Total current	Per port	≤4 A

**Derating
sensor current US/
actuator current UA**

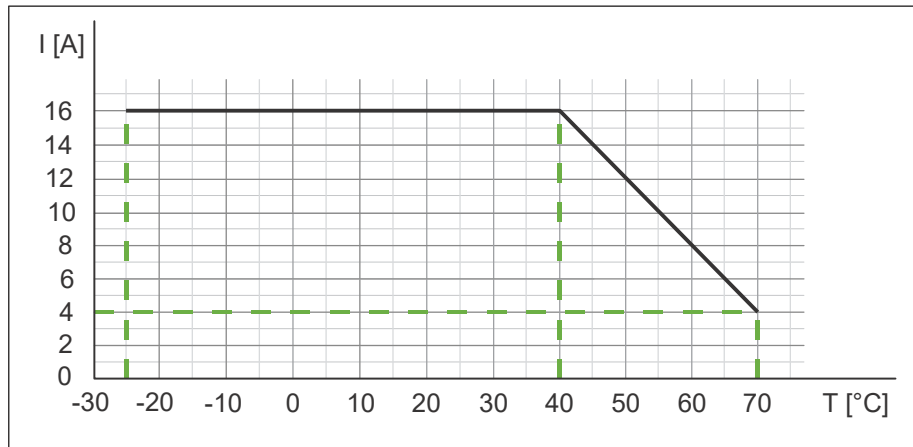

Fig. 4-1: Derating sensor current US and actuator current UA

**Derating total current,
sensor power supplies/
total current, outputs**

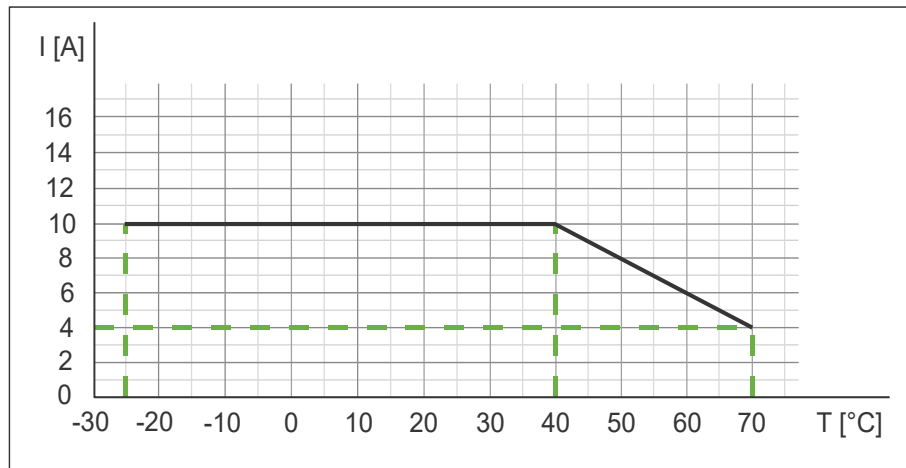

Fig. 4-2: Derating total current, sensor power supplies and total current, outputs

**Derating current per
sensor power supply/
output**

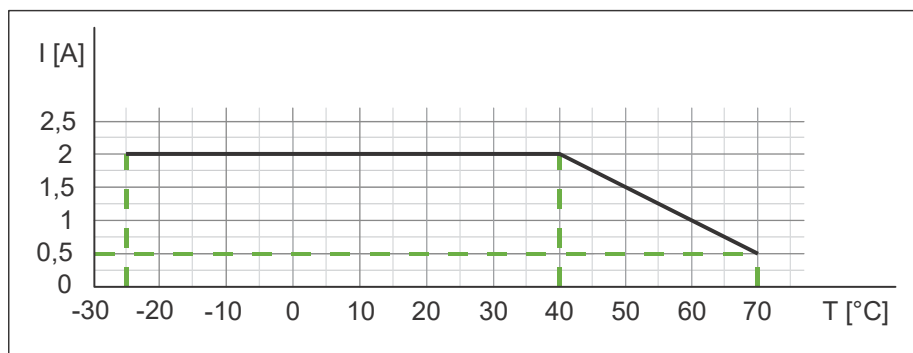

Fig. 4-3: Derating current per sensor power supply and output

4.2 Environmental characteristics

Climatic		
Operating temperature		-25 °C ... +70 °C
Storage temperature	Provide acclimatization for commissioning	-40 °C ... +85 °C
Transport temperature	Provide acclimatization for commissioning	-40 °C ... +85 °C
Relative humidity		≤95 %
Installation height	Above sea level	≤3000 m

Mechanical		
Oscillation test	EN 60068 Part 2-6	10 ... 58 Hz, Oscillation angle 0,35 mm, 58 ... 150 Hz; 20 g
Shock test	EN 60068 Part 2-27	50 g, duration 11 ms

Electrical safety		
Protection degree	EN 60529	IP67
Protection class	Using a SELV- or PELV- power supply	III
Pollution degree		2

EMC-inteference		
Radiated inteference E-field enclosure	EN 55016-2-3	Conform

EMC-immunity		
Electrostatic discharge (ESD)	EN 61000-4-2	Conform
Electromagnetic RF-fields	EN 61000-4-3	Conform
Fast transient burst	EN 61000-4-4	Conform
Surge AC	EN 61000-4-5	Conform
Conducted RF-fields	EN 61000-4-6	Conform
Voltage dips	EN 61000-4-11	Conform

4.3 Protection

Device protection		
Overvoltage protection		Yes
Overload protection module supply	To be ensured through load circuit monitoring	Yes
Inverse-polarity protection module supply		Yes
Short-circuit protection sensor supply		Electronically
Short-circuit protection output		Electronically
Protective circuit input	Internal	Suppressor diode

4.4 Mechanical data

Material data		
Housing material		Plastic
Assembly data		
Weight	Net	470 g
Dimensions	L x W x H	225.4 x 63 x 36 mm

4.5 Conformity, Approvals

Conformity, Approvals		
Product standard	EN 61131-2 Programmable logic controllers, Part 2	Compliant
CE	2014/30/EU 2011/65/EU	Compliant
UKCA		Compliant
EMC	2014/30/EU	Compliant
REACH	No. 1907/2006	SVHC List
WEEE	2012/19/EU	Compliant
ULus		E201820
RoHS	2011/65/EU & 2015/863	Exception 6c&7a
China RoHS	SJ/T 11364-2014	25 EPUP

Hazardous substance (有害物質)							
	Part Name	Lead	Mercury	Cadmium	Hexavalent	Polybrominated	Polybrominated
	零件名稱	(Pb) 鉛	(Hg) 汞	(Cd) 鎘	Chromium (Cr (VI)) 六价铬	biphenyls (PBB) 多溴联苯	diphenyl ethers (PBDE) 多溴联苯醚
	Component part PCB 組件部分 印刷电路板	X	O	O	O	O	O
	Connection Terminal/ Screws 接线端子 / 拧	X	O	O	O	O	O
O: Indicates that the content of the harmful substance in all homogeneous materials of the component part is below the limit defined in GB/T 26572. O: 表明該有害物質在組成部分的所有均質材料的含量低於按GB/ T26572定義的限制。 X: Indicates that the content of the harmful substance in at least one homogeneous material of the component part exceeds the limit defined in GB/T 26572. X: 表示該有害物質在組成部分中的至少一個均質材料的含量超過按GB / T26572定義的限制。							

5 Mounting

5.1 Requirements

- Conditions for mounting:
 - Even mounting surface to avoid mechanical tension
 - Provide suitable grounding
 - Suitable installation site in terms of vibration and shock load, temperature and humidity (see chap. 4 "Technical Data")
 - Protected connections to avoid stress to connectors or cables by personnel or device

5.2 Dimensions

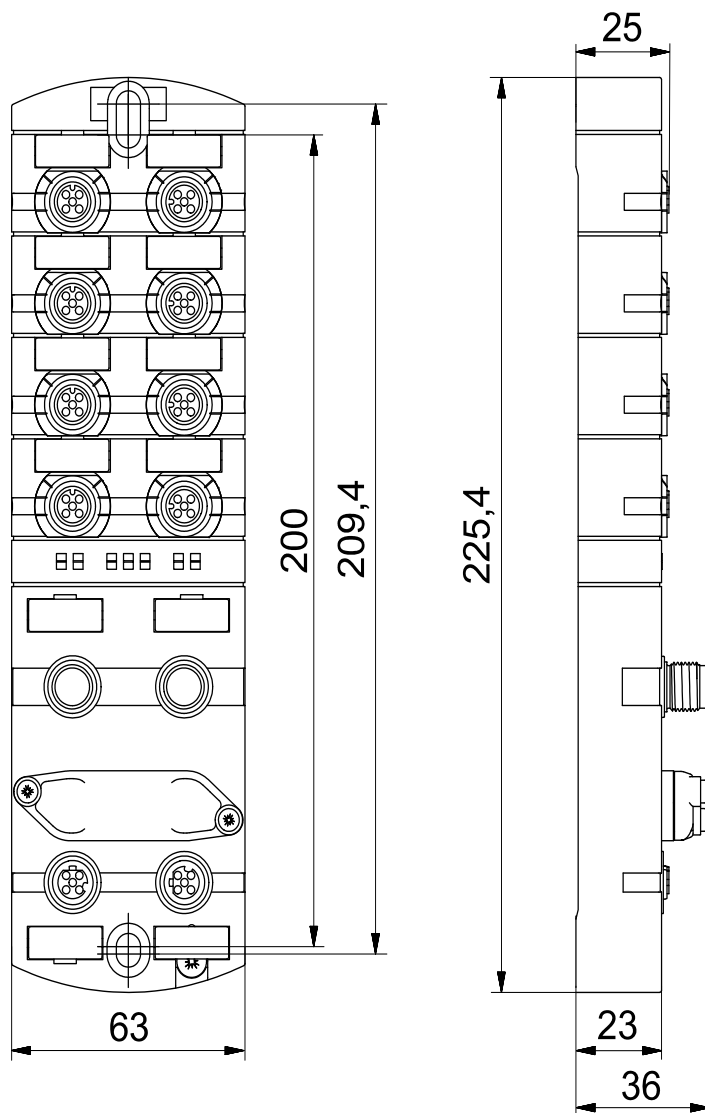

Fig. 5-1: Dimensions in mm

5.3 Mounting distance

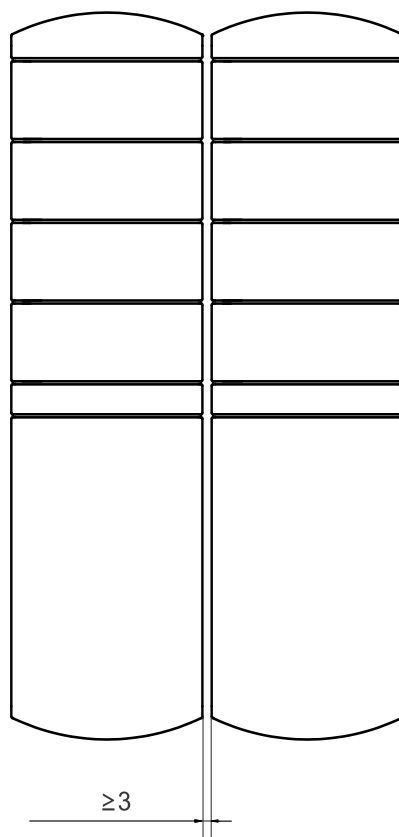

Fig. 5-2: Distance in mm



NOTE

→ For correct installation and improved heat dissipation, we recommend keeping a minimum distance of 3 mm when mounting the IMPACT67.



NOTE

→ If angled male connectors are used, a minimum distance of 50 mm is required.

5.4 Mounting the module

NOTICE

Material damage due to incorrect installation.

The fastening screws and tightening torques depend on the surface of the installation site.

- ➔ Use fastening screws that are suitable for the mounting surface structure.
- ➔ Carefully tighten the screws. The indicated tightening torques must be adhered to.

NOTICE

Material damage through improper use.

Do not use the devices as climbing aids. Improper use can cause the devices to break off or to be damaged otherwise.

- ➔ Install the devices in such a way that they cannot be used as climbing aid.

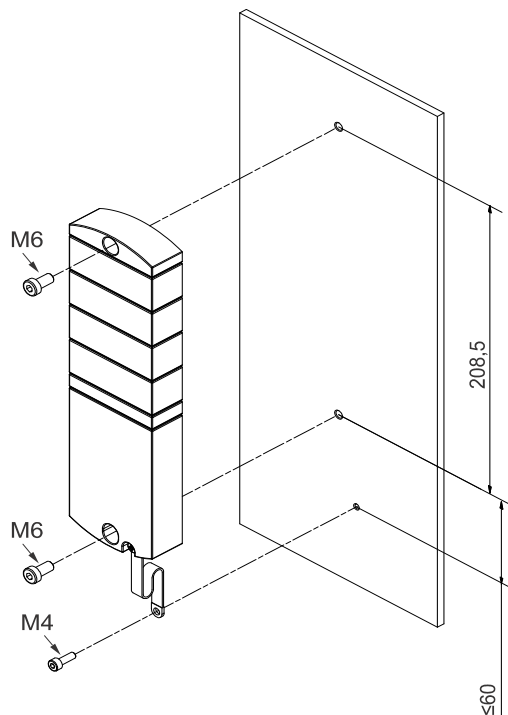

Fig. 5-3: Fasten module. Dimensions in mm (figure similar)

M6	3 Nm		Art.-No. 7000-98001-0000000
----	------	---	--------------------------------

Mount the module in the order indicated below:

- 1 | Slightly tighten the top M6 bolt.
- 2 | Align housing.
- 3 | Slightly tighten the lower M6 bolt.
- 4 | Tighten screws M6 according to the torque.
- 5 | *Grounding the module:*

Attach the grounding strap see chap. 5.4.1 "Functional ground".



NOTE

The screws and the grounding strap illustrated are not included with the device.

5.4.1 Functional ground



NOTE

Use a conductive screw to attach the grounding strap.

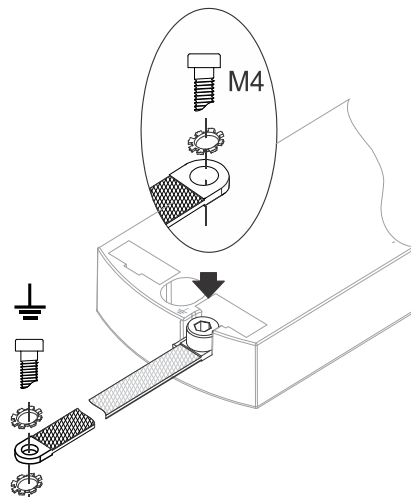



Fig. 5-4: Attach the grounding strap

M4	1,2 Nm		Art.-No. 7000-98001-0000000
----	--------	---	--------------------------------



For further information, refer to chap. 12.3.1 "System components"



The bolts and the grounding strap illustrated are not included in the scope of delivery. The grounding strap is available in the catalog or online shop of Murrelektronik GmbH shop.murrelektronik.com.

5.4.2 Addressing lid

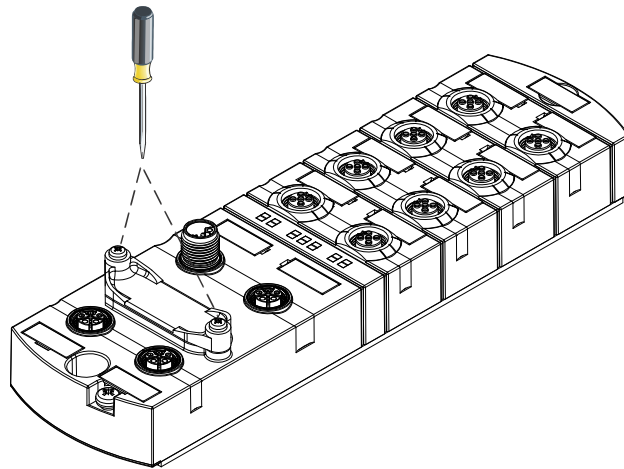



Fig. 5-5: Fasten rotary switch cover

M3	0,8 Nm		Art.-No. 7000-98001-0000000
----	--------	---	--------------------------------



For information on how to set the rotary switches, please refer to chapter 3.1.5 "Rotary switch settings"

6 Installation

6.1 Electrical Installation of the Module



DANGER!

High electrical voltage in the machine/system.

Death or severe injuries resulting from electric shock

→ When working on the machine/the modules, comply with the five safety rules of electrical engineering.

Protection of persons and material assets

→ According to DIN VDE 0105-100 - Operation of electrical systems - Part 100:
General definitions



WARNING!

Risk of fire due to short circuit

Damaged supply lines and/or modules may short circuit when damaged which may result in overheating and fire.

→ Provide intelligent current monitoring or fuse. The fuse must be designed for max. 9 A.



CAUTION!

Loss of function.

When disregarding, injuries and/or damage to property may occur.

→ Only install cables and accessories that meet the requirements and regulations for safety, electromagnetic compatibility and, if required, telecommunication terminal equipment specifications as well as the specification data.



CAUTION!

Hot surface!

Minor injuries and damage to devices caused by contact with the surface.

→ Wear thermally suitable gloves.

→ Use thermally suitable connecting cables only.

NOTICE

Damage to the machine/system due to improper switching on of the voltage sources

When the module is switched on with separate actuator and sensor voltage, the function of the digital inputs and outputs cannot be guaranteed unless the proper power-on order is performed.

→ Always switch on voltage sources in the following order:

- 1 | Switch on sensor voltage.
- 2 | Switch on actuator voltage.



NOTE

Use only a power supply unit that allows max. 60 V DC or 25 V AC under single-fault conditions. The power supply must comply with SELV or PELV.

6.1.1 Connecting sensors and actuators

Connecting the M12 ports

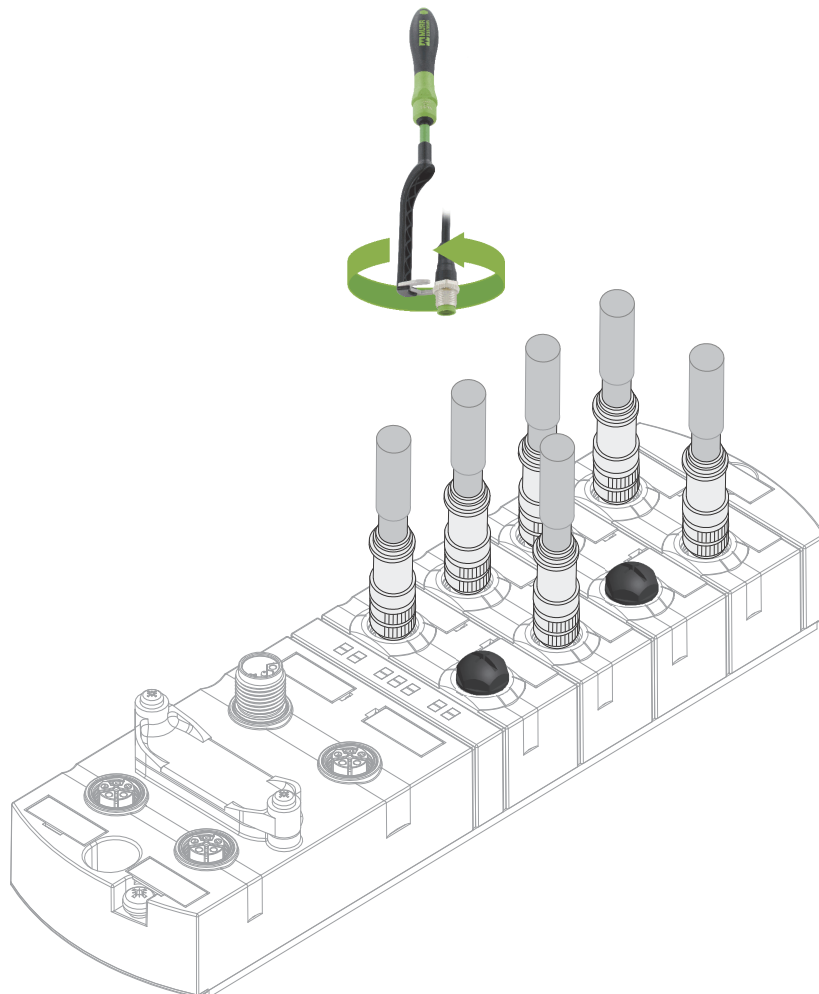
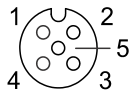

Fig. 6-1: Example of M12 connection inputs and outputs

M12	0,6 Nm		Art.-No. 7000-99102-0000000
-----	--------	---	--------------------------------



The pin assignment of the slots can be found in the chap. 3.1.3 "Pin assignment"



NOTE

Feeding in an external ground via M12 female connectors can lead to faults.
 → Do not feed external ground to the module via M12 female connectors.

**NOTE**

Maximum cable length of the sensor and actuator cables is limited to 30 m.

Sensor power supply**Please note:**

- Sensors can be supplied via **pin 1** (24 V) and **pin 3** (0 V) of the M12 female connectors.
- The maximum permissible current for the power supply of the sensors is **2 A**.
- In case of overcurrent or short circuit, the connected cable or sensor must be **disconnected** from the M12 female connector.

Supported IO-Link communication

The module supports the IO-Link communication using the following speeds:

- 4,800 baud (COM 1)
- 38,400 baud (COM 2)
- 230,400 baud (COM 3)

**NOTE**

The module automatically selects the appropriate communication speed for the IO-Link device.

**NOTE**

Maximum cable length is limited to 20 m for IO-Link connection.



You will find a wide range of connecting wires in the catalog or in the online shop of Murrelektronik GmbH at shop.murrelektronik.com

6.1.2 Connecting the power supply

Connect M12 male connector to POWER IN

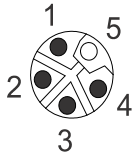

and M12 female connector to POWER OUT

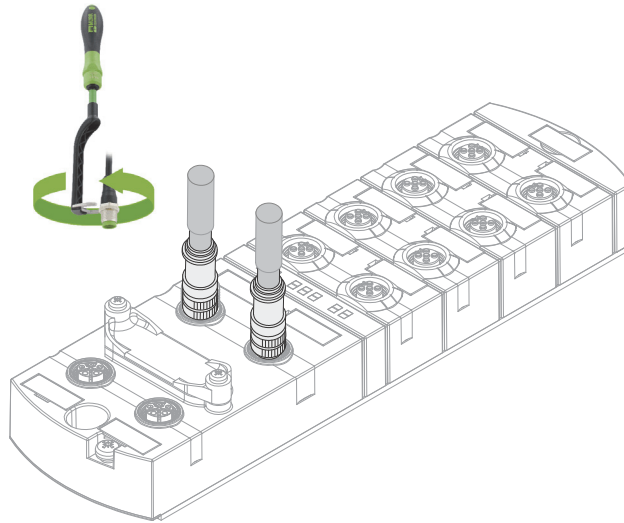
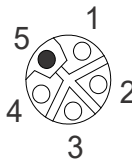

Fig. 6-2: Example of M12 connection (POWER)

M12	0,6 Nm		Art.-No. 7000-99102-000000
-----	--------	--	-------------------------------



The pin assignment of the slots can be found in the chap. 3.1.3 "Pin assignment"

6.1.3 Connecting EtherNet/IP bus

Connecting the M12 port

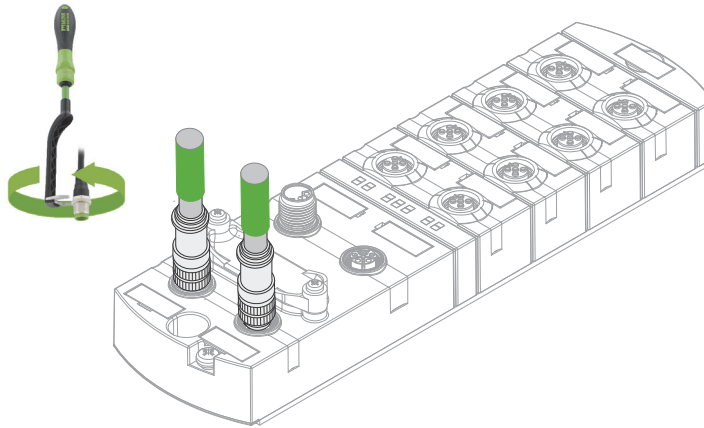
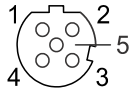

Fig. 6-3: Example of M12 connection (EtherNet/IP bus)

M12	0,6 Nm		Art.-No. 7000-99102-000000
-----	--------	---	-------------------------------



The pin assignment of the slots can be found in the chap. 3.1.3 "Pin assignment"

6.2 Ensuring Tightness (IP67)



CAUTION!

Not properly sealed.

Risk of personal injury and material damage due to failure caused by ingress of conductive liquids.

➔ Unused male and female connectors must be sealed.

Connection of cables

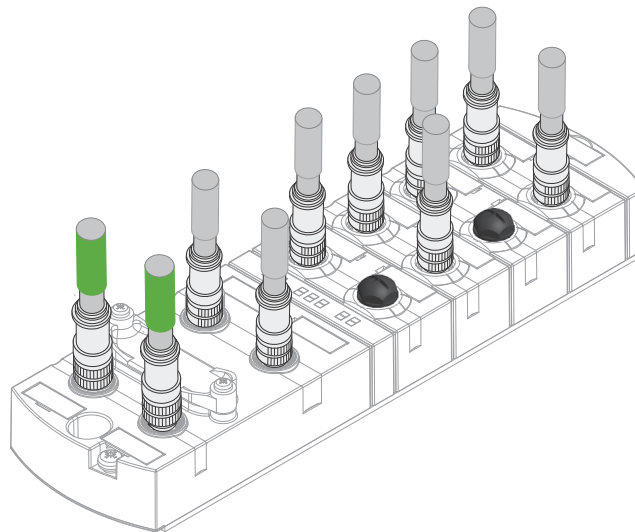

Fig. 6-4: Connection of cables

M12	0,6 Nm		Art.-No. 7000-99102-0000000
-----	--------	---	--------------------------------



You will find a wide range of connecting wires in the catalog or in the online shop of Murrelektronik GmbH at shop.murrelektronik.com



You will find suitable sealing connectors/screw plugs for the ports in our onlineshop shop.murrelektronik.com

7 Start-up



CAUTION!

Uncontrolled processes

Personal injury and material damage due to incorrectly performed start-up phases (e.g. first start-up, restart and configuration changes).

→ Always perform the start-up in this sequence:

- 1 | Mount and connect cables to the module.
- 2 | System check and approval by an expert.
- 3 | Put it into operation.

NOTICE

Functional errors in residential areas

Devices of EMC Class A may cause interference in residential areas.

→ The system operator must take appropriate measures.

7.1 Loading the EDS files

Tool used This chapter describes how to configure a module, using the example of Studio5000 Logix Designer from Rockwell Automation Germany.

Loading the EDS files Installing the EDS files and/or the module description file.

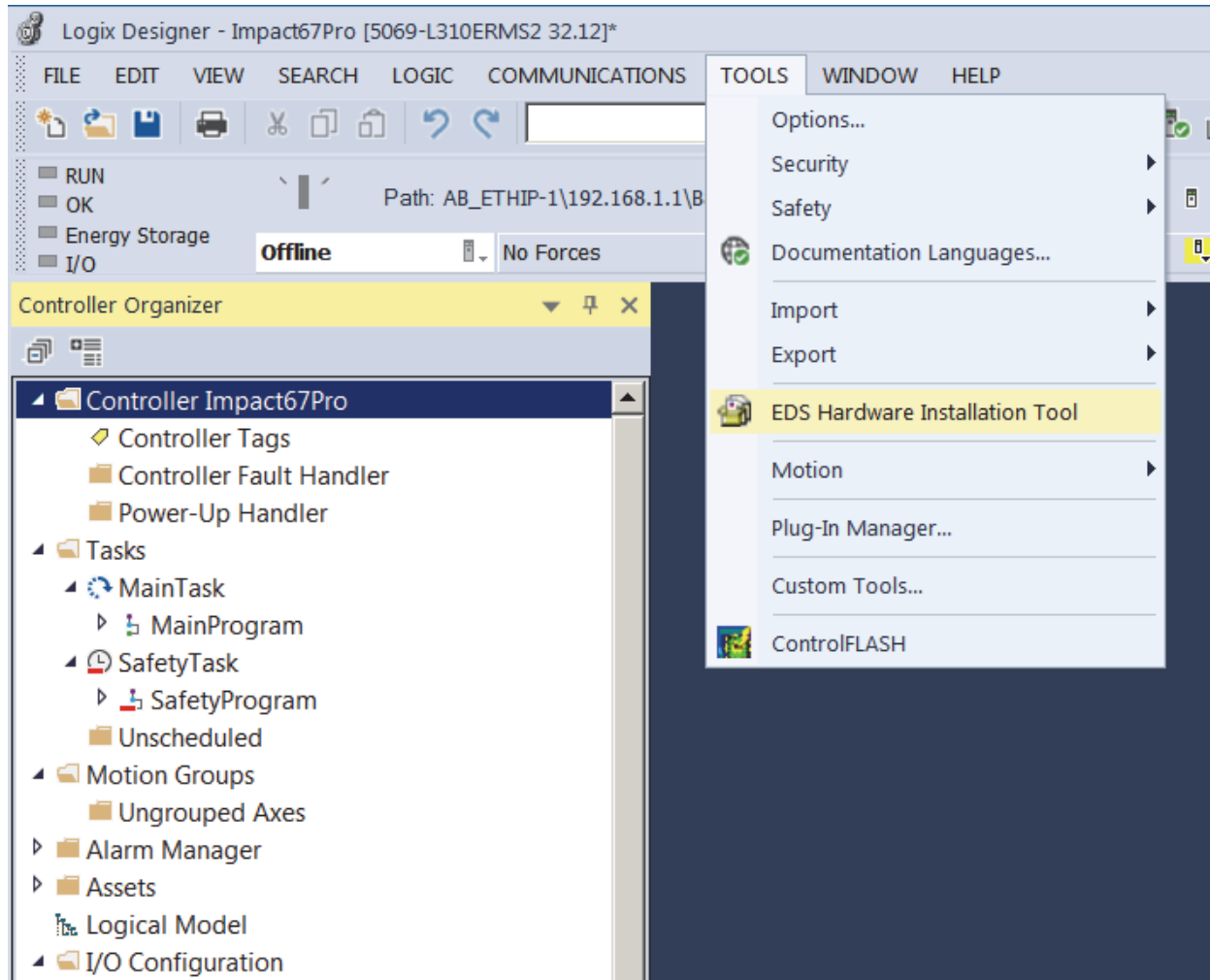

Fig. 7-1: Loading the EDS files

In **Project menu | Tools**,

➔ click **EDS Hardware Installation Tool**.

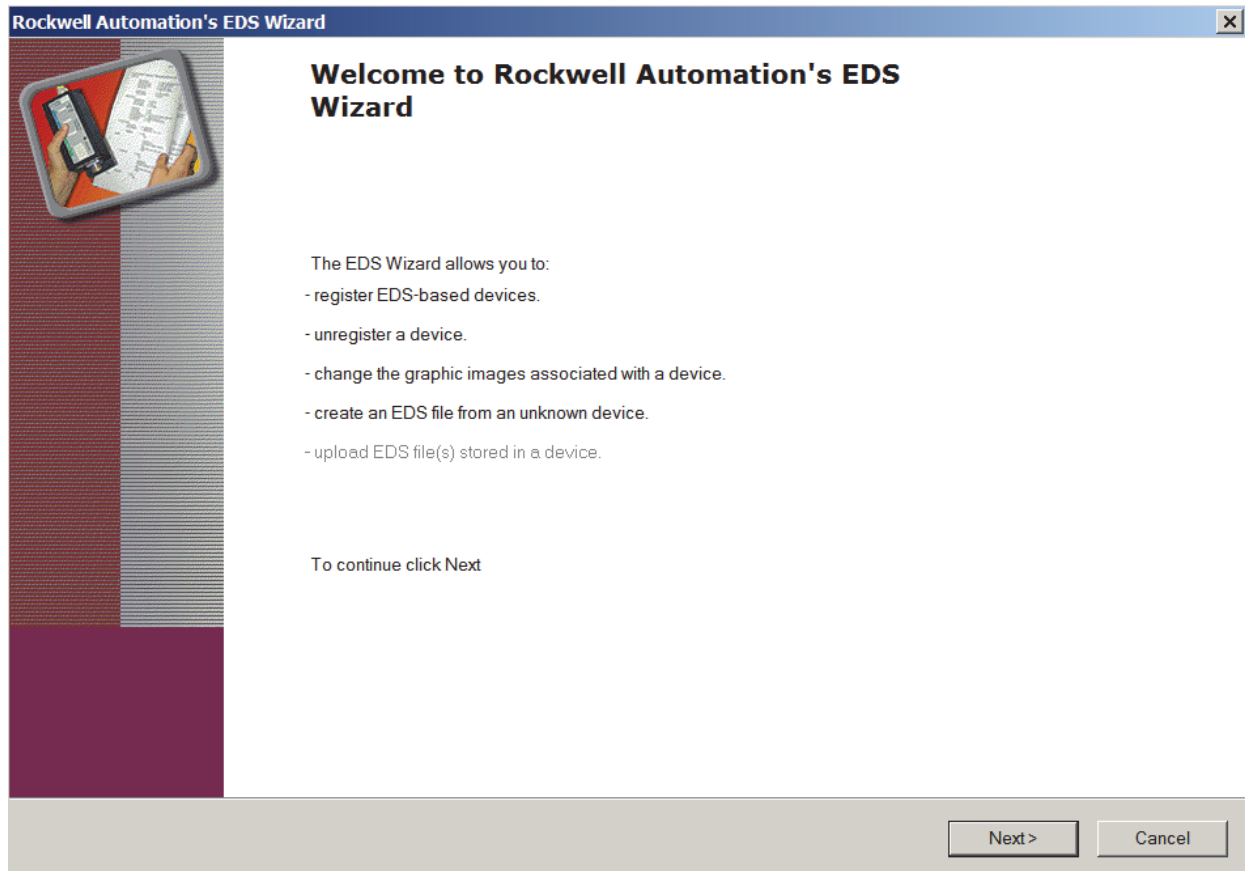

Fig. 7-2: EDS Wizard

- ➔ Click **Next** and follow the instructions of the dialog window.
- ➔ Finish the installation of the EDS files.

The modules can now be selected and added to the network.



The EDS file can be found in the online shop of Murrelektronik GmbH under the article number of the module.

7.2 Adding a module to the network

Adding new modules

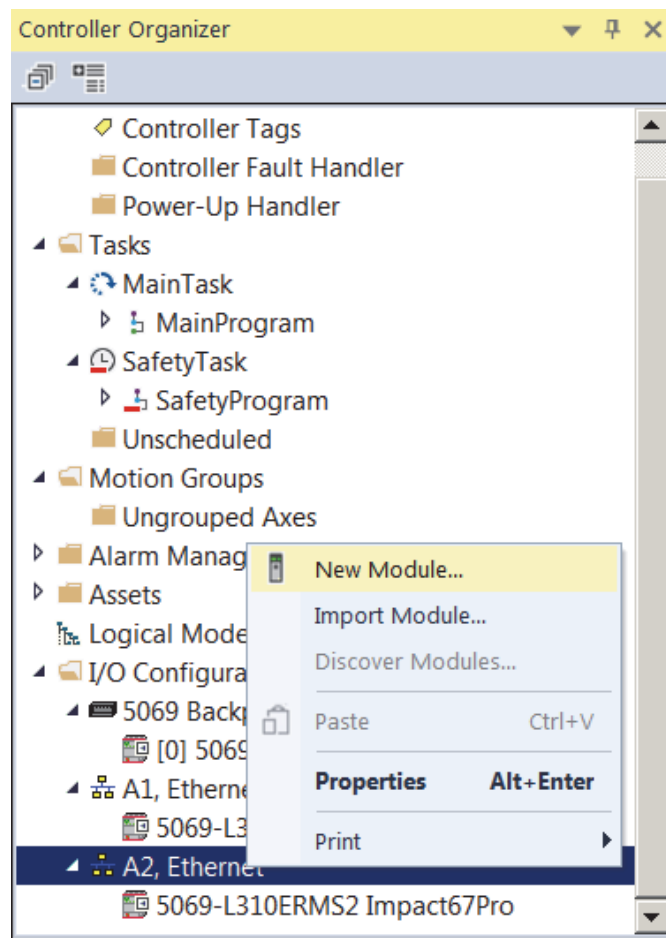

Fig. 7-3: New Module

In the **Controller Organizer | Ethernet**

→ Click **New Module**.

In the following dialog window, modules are shown which

- a | have been registered previously with an EDS or
- b | have already been delivered with the installation of the engineering software.

**Alternative
module selection**

The dialog window can also be called via the menu line **Files/New Component/Module**.

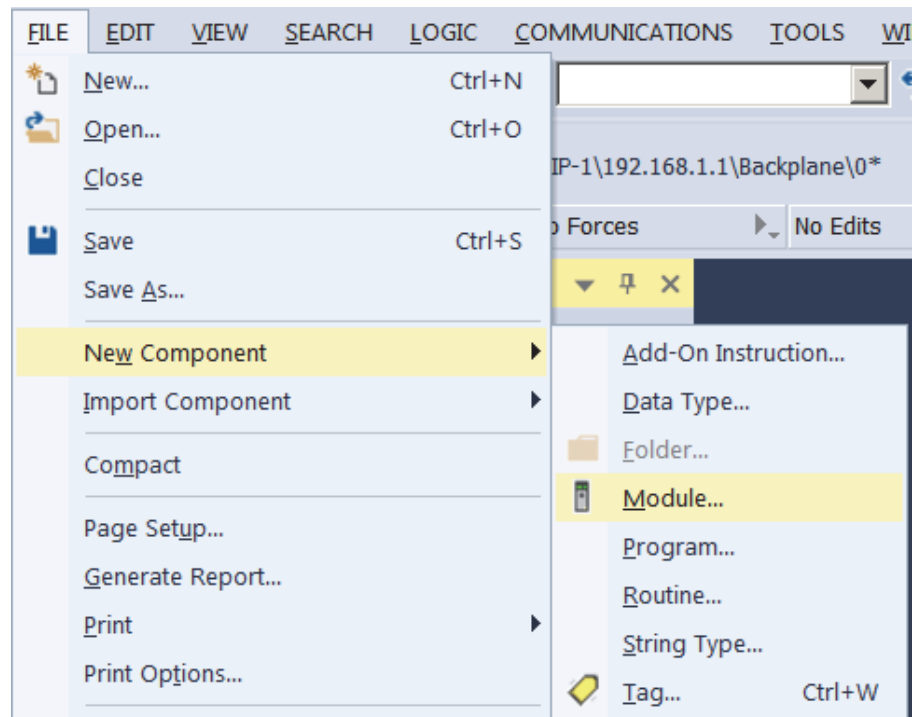

Fig. 7-4: Alternative module selection

Searching a module

Use the input mask to search for the module that you want to add to the network.

- a | Use search terms which describe the desired module, e.g. product number, product name or manufacturer.
- b | Use a filter from the dialog window.

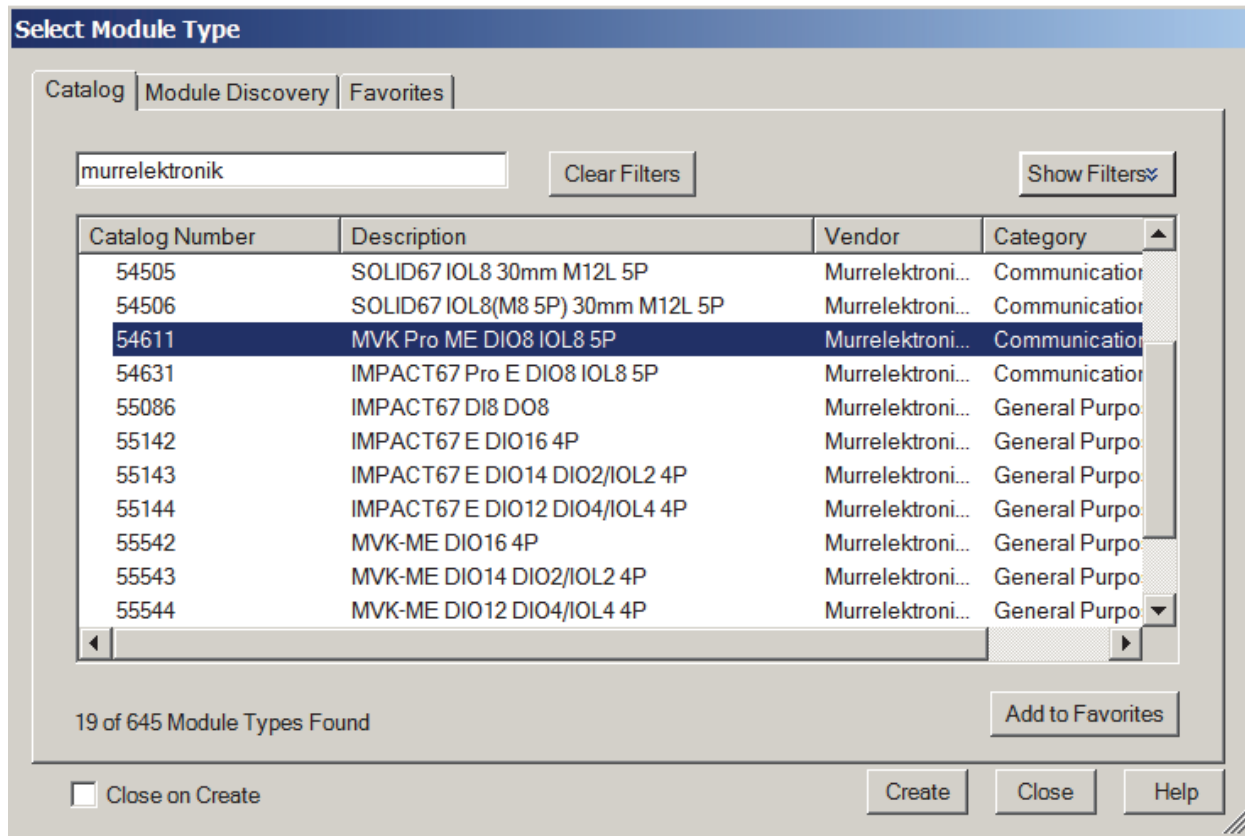

Fig. 7-5: Searching a module

- ➔ Mark the module.
- ➔ Double-click **Create**.

General settings

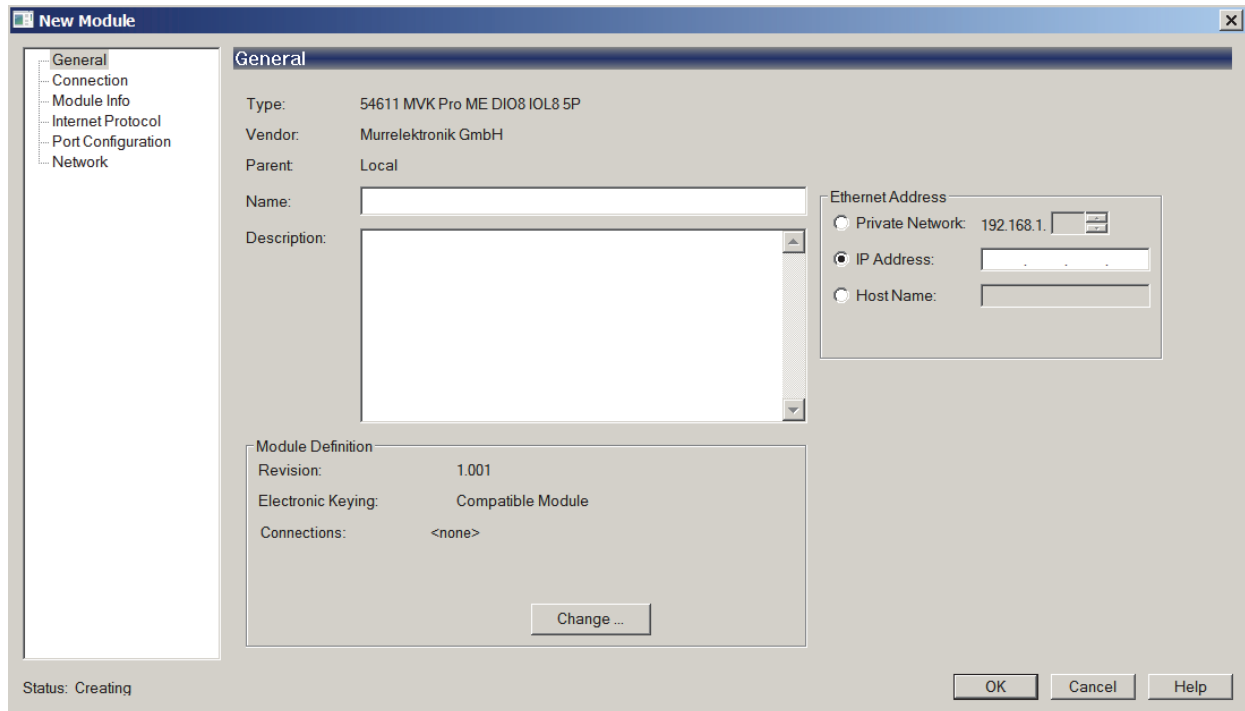

Fig. 7-6: General settings

In **New Module | General**

- ➔ Assign a unique module name.
- ➔ Assign the IP address.

In **New Module | Connection**

- ➔ Assign further settings, e.g. the RPI settings.
- ➔ Add the module to the network by pressing **OK**.

Selecting the connection

In order to choose the best connection for every application, you can choose from various connection options:

- a | when adding the module to the network, select the right connection *or*
- b | call the settings again by double-clicking the module.

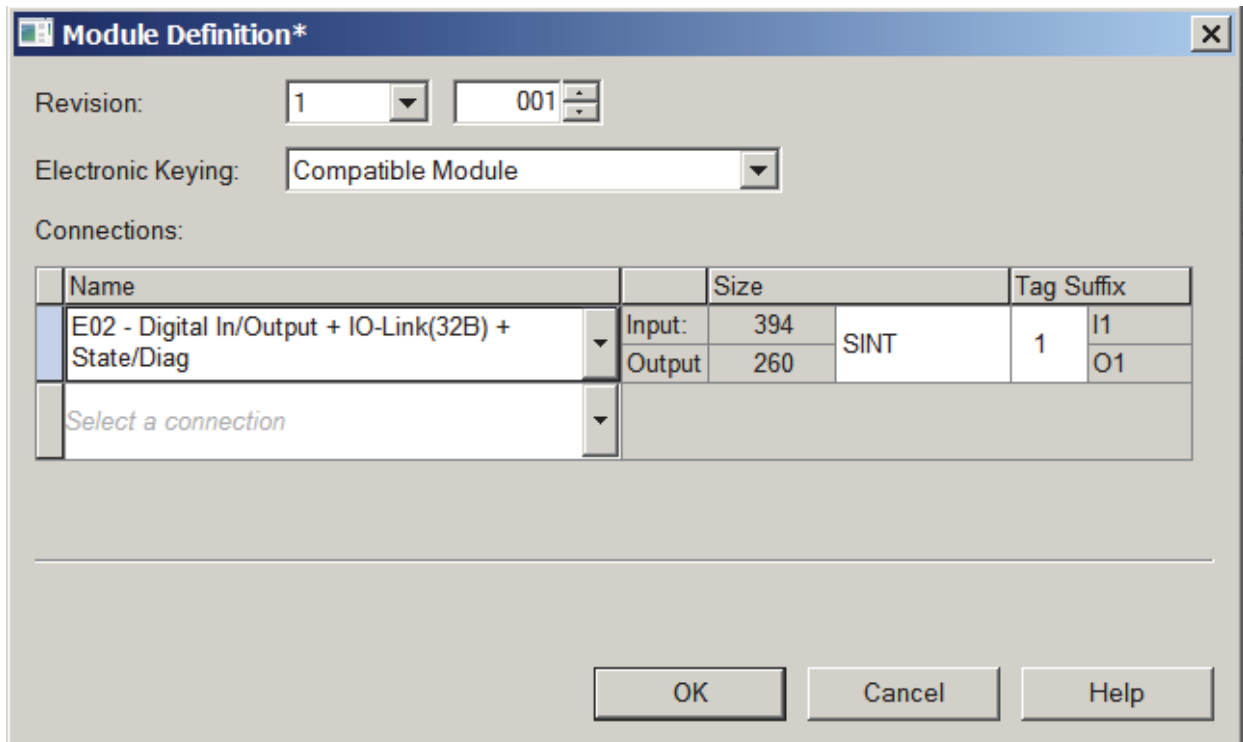

Fig. 7-7: Module Definition

In Module Definition

- ➔ Click **Change**.
A new window appears.
- ➔ Set the number or the type of connection 7.3.2 "Connection matrix" here.
- ➔ Click the preset connection (**Exclusive Owner**).
- ➔ Select the connection that meets the requirements.
The list of all connections that can be set is displayed.



NOTICE

The modules support up to 3 connections at a time (1 Exclusive Owner and 2 Non-Exclusive-Owner connections).

7.3 Commissioning without EDS

7.3.1 Connections, parameters and properties



NOTICE

Listen Only connections can only be established to Multicast Non-Listen Only connections of the **over EDS** category.

This selects the configuration instance to be used for the instance of the Non-Listen Only connection used.

7.3.2 Connection matrix

Exclusive Owner connection

Assembly configuration				Description	Input assembly		Output assembly	
over EDS		over web server			Instance	Length	Instance	Length
Instance	Length	Instance	Length					
170	xx	171	0					
E02		WE02		Digital IOs, IOL 32 bytes with status and diagnostics	101	394	111	259

Tab. 7-1: Exclusive Owner connection

Input Only connection

Assembly configuration				Description	Input assembly		Output assembly	
over EDS		over web server			Instance	Length	Instance	Length
Instance	Length	Instance	Length					
170	xx	171	0					
I02		WI02		Digital IOs, IOL 32 bytes with status and diagnostics	101	394	193	0

Tab. 7-2: Input Only connection

Listen Only connection

Connection name	Description	Input assembly		Output assembly	
		Instance	Length	Instance	Length
L02	Digital IOs, IOL 32 bytes with status and diagnostics	101	394	192	0

Tab. 7-3: Listen Only connection

7.3.3 Assemblies

Sequence of configuration bytes

Parameters	Instance 170	Instance 171
Total size in bytes	384	0
General	0 ... 1	
Diagnostic	2 ... 19	
IO-Link port X0	20 ... 43	
IO-Link port X1	44 ... 67	
IO-Link port X2	68 ... 91	
IO-Link port X3	92 ... 115	
IO-Link port X4	116 ... 139	
IO-Link port X5	140 ... 163	
IO-Link port X6	164 ... 187	
IO-Link port X7	188 ... 211	
OPC/UA	212 ... 217	
MQTT	218 ... 379	
WebUI	380 ... 381	
JSON	382 ... 383	

Tab. 7-4: Assembly instance 170/171

Sequence of input bytes

Parameters	Instance 101
Total size in bytes	394
Digital input DI	0 ... 1
DI Qualifier	2 ... 5
System status	6 ... 9
IO-Link port X0 input data	10 ... 41
IO-Link port X0 input status	42 ... 49
IO-Link port X1 input data	50 ... 81
IO-Link port X1 input status	82 ... 89
IO-Link port X2 input data	90 ... 121
IO-Link port X2 input status	122 ... 129
IO-Link port X3 input data	130 ... 161
IO-Link port X3 input status	162 ... 169
IO-Link port X4 input data	170 ... 201
IO-Link port X4 input status	202 ... 209
IO-Link port X5 input data	210 ... 241
IO-Link port X5 input status	242 ... 249
IO-Link port X6 input data	250 ... 281
IO-Link port X6 input status	282 ... 289
IO-Link port X7 input data	290 ... 321
IO-Link port X7 input status	322 ... 329
Diagnostic buffer	330 ... 393

Tab. 7-5: Assembly instance 101

Sequence of output bytes

Parameters	Instance 111
Total size in bytes	260
Digital output	0 ... 1
IO-Link port X0 output data	2 ... 33
IO-Link port X1 output data	34 ... 65
IO-Link port X2 output data	66 ... 97
IO-Link port X3 output data	98 ... 129
IO-Link port X4 output data	130 ... 161
IO-Link port X5 output data	162 ... 193
IO-Link port X6 output data	194 ... 225
IO-Link port X7 output data	226 ... 257
Diagnostic confirmation	258 ... 259

Tab. 7-6: Assembly instance 111

7.3.4 Configuration values

NOTICE

→ To avoid unexpected behavior of the fieldbus device, use only the values listed in this manual.

General parameters

Byte	Parameters	Value	Default value	Description
0	Pin/Port based IO layout for digital channels	IO layout: <input type="checkbox"/> 0 = Port based <input type="checkbox"/> 1 = Pin based	0	Parameterizes the layout of the I/O data.

Tab. 7-7: General parameters

Diagnostic parameters

Byte	Parameters	Value	Default value	Description
0	Global Diagnostic Report	<input type="checkbox"/> 0 = Disabled <input type="checkbox"/> 1 = Enabled	1	Global diagnostics report
1	Under Voltage Sensor Supply Diagnostic Message	<input type="checkbox"/> 0 = Do not report <input type="checkbox"/> 1 = Report	1	Undervoltage US diagnostic report
2 - 3	Under Voltage Sensor Supply Threshold	<input type="checkbox"/> 0 = Default <input type="checkbox"/> 17500 = 17.5 V ... 18.0 V <input type="checkbox"/> 18000 = 18.0 V ... 18.5 V <input type="checkbox"/> 18500 = 18.5 V ... 19.0 V <input type="checkbox"/> 19000 = 19.0 V ... 19.5 V <input type="checkbox"/> 19500 = 19.5 V ... 20.0 V	0	Threshold value US at undervoltage
4	Under Voltage Actuator Supply Diagnostic Message	<input type="checkbox"/> 0 = Do not report <input type="checkbox"/> 1 = Report	1	Undervoltage UA diagnostic report
5 - 6	Under Voltage Actuator Supply Threshold	<input type="checkbox"/> 0 = Default <input type="checkbox"/> 17500 = 17.5 V ... 18.0 V <input type="checkbox"/> 18000 = 18.0 V ... 18.5 V <input type="checkbox"/> 18500 = 18. V ... 19.0 V <input type="checkbox"/> 19000 = 19.0 V ... 19.5 V <input type="checkbox"/> 19500 = 19.5 V ... 20.0 V	0	Threshold value UA at undervoltage
7	No Actuator Supply Diagnostic Message	<input type="checkbox"/> 0 = Do not report <input type="checkbox"/> 1 = Report	1	Diagnostic report no UA

Byte	Parameters	Value	Default value	Description
8	LED Indication For Suppressed Diagnostic Messages	<ul style="list-style-type: none"> ■ 0 = No LED indication ■ 1 = LED indication 	0	LED indication for suppressed diagnostic messages
9	Diagnostic Message Acknowledgement	<ul style="list-style-type: none"> ■ 0 = Disabled ■ 1 = Enabled 	0	Confirmation of diagnostic message
10	Port X0 Diagnostic Report	<ul style="list-style-type: none"> ■ 0 = Report All Diagnostic Messages ■ 1 = Report All Diagnostic Messages Except For Wire Break ■ 2 = Report Only Wire Break Diagnostic Messages 	0	Port X0 Diagnostic Report
11	Port X1 Diagnostic Report	<ul style="list-style-type: none"> ■ 0 = Report All Diagnostic Messages ■ 1 = Report All Diagnostic Messages Except For Wire Break ■ 2 = Report Only Wire Break Diagnostic Messages 	0	Port X1 Diagnostic Report
12	Port X2 Diagnostic Report	<ul style="list-style-type: none"> ■ 0 = Report All Diagnostic Messages ■ 1 = Report All Diagnostic Messages Except For Wire Break ■ 2 = Report Only Wire Break Diagnostic Messages 	0	Port X2 Diagnostic Report
13	Port X3 Diagnostic Report	<ul style="list-style-type: none"> ■ 0 = Report All Diagnostic Messages ■ 1 = Report All Diagnostic Messages Except For Wire Break ■ 2 = Report Only Wire Break Diagnostic Messages 	0	Port X3 Diagnostic Report
14	Port X4 Diagnostic Report	<ul style="list-style-type: none"> ■ 0 = Report All Diagnostic Messages ■ 1 = Report All Diagnostic Messages Except For Wire Break ■ 2 = Report Only Wire Break Diagnostic Messages 	0	Port X4 Diagnostic Report
15	Port X5 Diagnostic Report	<ul style="list-style-type: none"> ■ 0 = Report All Diagnostic Messages ■ 1 = Report All Diagnostic Messages Except For Wire Break ■ 2 = Report Only Wire Break Diagnostic Messages 	0	Port X5 Diagnostic Report
16	Port X6 Diagnostic Report	<ul style="list-style-type: none"> ■ 0 = Report All Diagnostic Messages ■ 1 = Report All Diagnostic Messages Except For Wire Break ■ 2 = Report Only Wire Break Diagnostic Messages 	0	Port X6 Diagnostic Report
17	Port X7 Diagnostic Report	<ul style="list-style-type: none"> ■ 0 = Report All Diagnostic Messages ■ 1 = Report All Diagnostic Messages Except For Wire Break ■ 2 = Report Only Wire Break Diagnostic Messages 	0	Port X7 Diagnostic Report

Tab. 7-8: Diagnostic parameters

IO-Link port X0 ... X7 parameters

Byte	Parameters	Value	Default value	Description
0	IO-Link Function Pin 4	<ul style="list-style-type: none"> ■ 0 = Deactivated ■ 1 = IO-Link Manual Configuration ■ 2 = IO-Link Autostart ■ 3 = Digital Input NO ■ 4 = Digital Output ■ 97 = Digital Input NC 	0	IO-Link function pin 4
1	Validation&Backup	<ul style="list-style-type: none"> ■ 0 = No Device check ■ 1 = Type compatible Device V1.0 ■ 2 = Type compatible Device V1.1 ■ 3 = Type compatible Device V1.1, Backup + Restore ■ 4 = Type compatible Device V1.1, Restore 	0	Validation and backup, * see note
2	Behavior Pin 2 (Ch1Y)	<ul style="list-style-type: none"> ■ 0 = Automatic Mode (DIO) ■ 1 = Digital Input ■ 2 = Digital Output ■ 5 = AUX Power ■ 6 = Digital Input NC ■ 7 = Deactivated 	0	Behavior Pin 2 (Ch1Y)
3	PortCycleTime	<ul style="list-style-type: none"> ■ 0: As fast as possible ■ 1 - 255: Bit0..5 Multiplier / Bit6..7 TimeBase[ms] 	0	Port cycle time
4 - 5	Vendor ID	<ul style="list-style-type: none"> ■ Vendor ID of the attached IO-Link device for the use with validation setting 	0	
6 - 9	Device ID	<ul style="list-style-type: none"> ■ Device ID of the attached IO-Link device for the use with validation setting 	0	
10	RESERVED		0	Reserved for future use
11	IO-Link Event Integration	<ul style="list-style-type: none"> ■ 0 = Standard Integration ■ 1 = Murrelektronik Integration ■ 2 = Murrelektronik IO-Link Extended Integration 	0	IO-Link event integration
12	Digital Input Signal Filter Pin 4	<ul style="list-style-type: none"> ■ 0 = No Filter ■ 1 = 1 ms ■ 2 = 3 ms ■ 3 = 5 ms ■ 4 = 10 ms ■ 5 = 15 ms 	0	Digital input signal filter pin 4
13	Digital Input Signal Filter Pin 2	<ul style="list-style-type: none"> ■ 0 = No Filter ■ 1 = 1 ms ■ 2 = 3 ms ■ 3 = 5 ms ■ 4 = 10 ms ■ 5 = 15 ms 	0	Digital input signal filter pin 2
14 - 15	RESERVED		0	Reserved for future use
16	Digital Port Function Configuration Pin 1	<ul style="list-style-type: none"> ■ 0 = Deactivated ■ 1 = L+ (US) Sensor Supply 	1	Digital port function configuration pin 1
17	Output Current Limitation for Pin 1	<ul style="list-style-type: none"> ■ 0 = 0.5 A ■ 1 = 1.0 A ■ 2 = 1.5 A ■ 3 = 2.0 A 	3	Output current limitation for Pin 1

Byte	Parameters	Value	Default value	Description
18	Output Current Limitation for Pin 2	<ul style="list-style-type: none"> ■ 0 = 0.5 A ■ 1 = 1.0 A ■ 2 = 1.5 A ■ 3 = 2.0 A 	3	Output current limitation for Pin 2
19	Output Current Limitation for Pin 4	<ul style="list-style-type: none"> ■ 0 = 0.5 A ■ 1 = 1.0 A ■ 2 = 1.5 A ■ 3 = 2.0 A 	0	Output current limitation for Pin 4
20 - 23	RESERVED		0	Reserved for future use

Tab. 7-9: IO-Link port X0 ... X7 parameters



* When switching to the “Restore” state, any device configurations previously stored in the device are discarded, especially when switching from “Back-up&Restore” to “Restore”.

If a compatible device is connected for the first time in the “Restore” state, the master fetches the data storage data (one-time backup) from the device, saves it and then sends this data to each newly connected, compatible device with a different configuration (restore).



These parameters are repeated for each IO-Link port of the device.

OPC/UA parameters

Byte	Parameters	Value	Default value	Description
0	Use Of OPC/UA	<input type="checkbox"/> 0 = Disabled <input type="checkbox"/> 1 = Enabled	0	Activates or disables the OPC/UA Server function
1 - 2	OPC/UA TCP Port Number	<input type="checkbox"/> 1024 – 49151 TCP port number	4840	Defines on which port the OPC/UA Server is active
3	Allow OPC/UA Clients to Write ISDU Data	<input type="checkbox"/> 0 = Disabled <input type="checkbox"/> 1 = Enabled	0	Activates or disables the option to write ISDU data from a OPC/UA client
4	Allow OPC/UA Clients to Write Output Data	<input type="checkbox"/> 0 = Disabled <input type="checkbox"/> 1 = Enabled	0	Activates or disables the option to write output data from a OPC/UA client
5	RESERVED		0	Reserved for future use

Tab. 7-10: OPC/UA parameters

MQTT parameters

Byte	Parameters	Value	Default value	Description
0	Use Of MQTT	<input type="checkbox"/> 0 = Disabled <input type="checkbox"/> 1 = Enabled	0	Activates or disables the MQTT function
1 - 4	MQTT Server IP Address	Value of IP MQTT Server IP Address	0xC0AB01FE = 192.171.1.254	Sets the IP address of the MQTT server
5 - 27	MQTT Client ID	Client ID of the MQTT Client	"MqttClient"	Sets the ID which the device shall use to send MQTT data
28 - 91	MQTT Client Head Topic	MQTT Client Head Topic	""	Sets the Head Topic to which the device writes MQTT data
92 - 155	MQTT Topic For System Data	MQTT Topic For System Data	""	Sets the topic for system data to which the device writes MQTT data

Tab. 7-11: MQTT parameters

WebUI parameters

Byte	Parameters	Value	Default value	Description
0	Use Of WebUI	<input type="checkbox"/> 0 = Disabled <input type="checkbox"/> 1 = Enabled	1	Activates or disables the WebUI
1	RESERVED		0	Reserved for future use

Tab. 7-12: WebUI parameters

JSON parameters

Byte	Parameters	Value	Default value	Description
0	Use Of JSON	<input type="checkbox"/> 0 = Disabled <input type="checkbox"/> 1 = Enabled	0	Activates or disables the option to send and receive JSON communication
1	RESERVED		0	Reserved for future use

Tab. 7-13: JSON parameters

8 Configuration and parameterization



 **WARNING!**

Protection function may be impaired if the module configuration is changed.

The person who makes the changes is responsible for maintaining the protective function of the device.

- ➔ Make sure that only authorized persons change the configuration.
- ➔ If you change the configuration, use the password hierarchy provided by your engineering software.
- ➔ After every change to the configuration, test the protection equipment for efficiency.

8.1 Module configuration

Overview

There are two options for configuring the devices:

1. Download an EDS file from the Murrelektronik website or the place of purchase.

Then, import the EDS files into your programming software (see chap. 7.1 "Loading the EDS files" for an example of how to do this). Using the EDS file allows you to benefit from the advantages of a preconfigured connection.

2. Configure the devices using the integrated web server.



NOTE

To transfer index changes via the Webserver and acyclic ISDU writes to the DataStorage, a ParamDownloadStore command must be sent after the index changes.

- ➔ The ParamDownloadStore command can be triggered by writing value 0x05 to index 0x02.

Configuration via EDS

After the import of the EDS in the programming software and the selection of a connection suitable for the application, the configuration files can be found in the controller tags.

The input and output tags associated with the device can be found next to it.

Name	Value	Force Mask	Style	Data Type	Class	Description	Constant
MVK_PRO:C	(...)	(...)	(...)	._0280:54611_3DF...	Standard		<input type="checkbox"/>
▶ MVK_PRO:C.Pin_Port_based_IO_layout_for_digital_cha	0		Decimal	SINT	Standard		
▶ MVK_PRO:C.Quick_Connect	0		Decimal	SINT	Standard		
▶ MVK_PRO:C.Diag_Param_Global_Diagnostic_Report	1		Decimal	SINT	Standard		
▶ MVK_PRO:C.Diag_Param_Under_Voltage_Sensor_Supply1	1		Decimal	SINT	Standard		
▶ MVK_PRO:C.Diag_Param_Under_Voltage_Sensor_Supply2	0		Decimal	INT	Standard		
▶ MVK_PRO:C.Diag_Param_Under_Voltage_Actuator_Supp1	1		Decimal	SINT	Standard		
▶ MVK_PRO:C.Diag_Param_Under_Voltage_Actuator_Supp2	0		Decimal	INT	Standard		
▶ MVK_PRO:C.Diag_Param_No_Actuator_Supply_Diagnosti	1		Decimal	SINT	Standard		
▶ MVK_PRO:C.Diag_Param_LED_Indication_For_Suppresse	0		Decimal	SINT	Standard		
▶ MVK_PRO:C.Diag_Param_Diagnostic_Message_Acknowled	0		Decimal	SINT	Standard		
▶ MVK_PRO:C.Diag_Param_Port_X0_Diagnostic_Report	0		Decimal	SINT	Standard		
▶ MVK_PRO:C.Diag_Param_Port_X1_Diagnostic_Report	0		Decimal	SINT	Standard		
▶ MVK_PRO:C.Diag_Param_Port_X2_Diagnostic_Report	0		Decimal	SINT	Standard		
▶ MVK_PRO:C.Diag_Param_Port_X3_Diagnostic_Report	0		Decimal	SINT	Standard		
▶ MVK_PRO:C.Diag_Param_Port_X4_Diagnostic_Report	0		Decimal	SINT	Standard		

Fig. 8-1: Configuration via EDS

All configuration tags have a specific name that describes the function of the areas.

→ Enter the appropriate values for your application.

Each time a connection with the control system is established, the device is correctly configured.



For more information on the adjustable values, please refer to chapter 7.3.4 "Configuration values"

WebUI

The device can also be configured via WebUI if required. To use this function, one of the Exclusive Owner connections starting with the "WE" symbols must be selected when configuring the connection in the PLC software.



Chapter 10 "Web server" parameters.

8.2 Setting parameters

Setting parameters

➔ Navigate to the **controller tags** in the **Controller Organizer** program window, as shown in the figure.

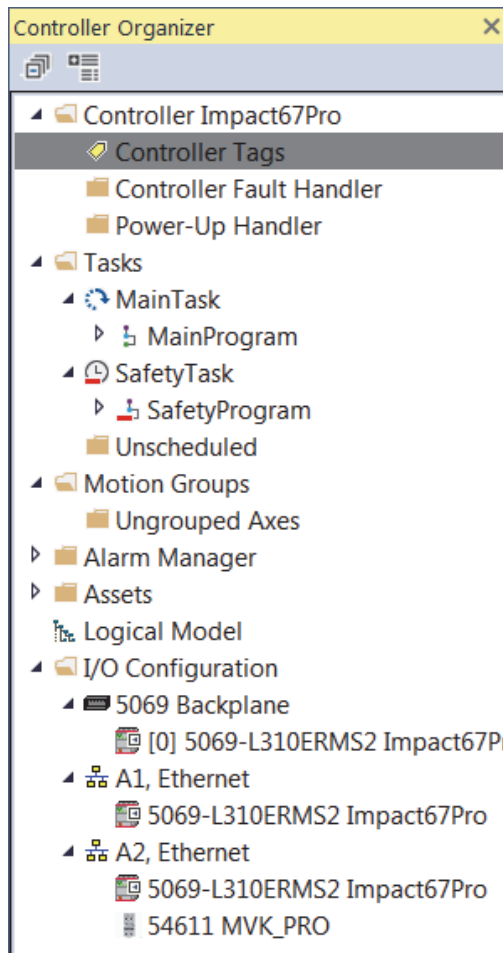

Fig. 8-2: Controller Organizer window

➔ Double-click the **Controller Tags** entry.
The overview of the process and configuration data opens.

Name	Value	Force Mask	Style	Data Type	Class	Description	Constant
▶ MVK_PRO:C				_0280:54611_3DF...	Standard		☐
▶ MVK_PRO:I1				_0280:54611_B60...	Standard		☐
▶ MVK_PRO:O1				_0280:54611_9E8B...	Standard		☐

Fig. 8-3: Process and configuration data

➔ Click the plus symbol in the configuration data line **Name_Of_Module: C**.
All parameters of the device are visible.

➔ Enter the values for the application.



NOTICE

Configuration is transferred to device once during Forward Open process. Communication between controller and device must be interrupted for configuration changes to take place.



For adjustable parameter values, refer to chap. 7.3.4 "Configuration values"

8.3 Requested Packet Interval (RPI) configuration

Setting the RPI values

Searching the module

When setting up an EtherNet/IP system, the RPI value must be carefully set in the controller.

To set the RPI values, the module properties must be selected.

In **Controller Organizer**:

- ➔ Double-click the module or
- ➔ Right-click the module and select **Properties** from the context menu.

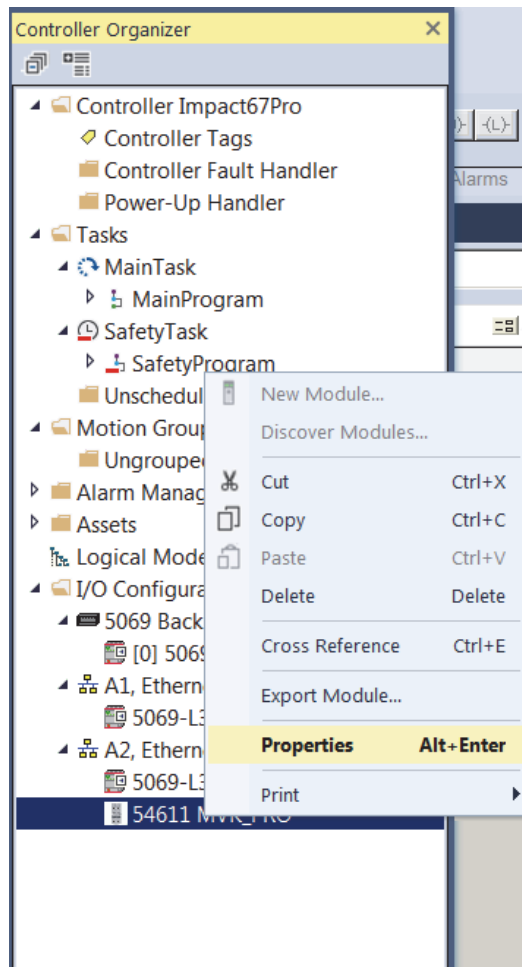

Fig. 8-4: Searching a module

Setting the RPI values

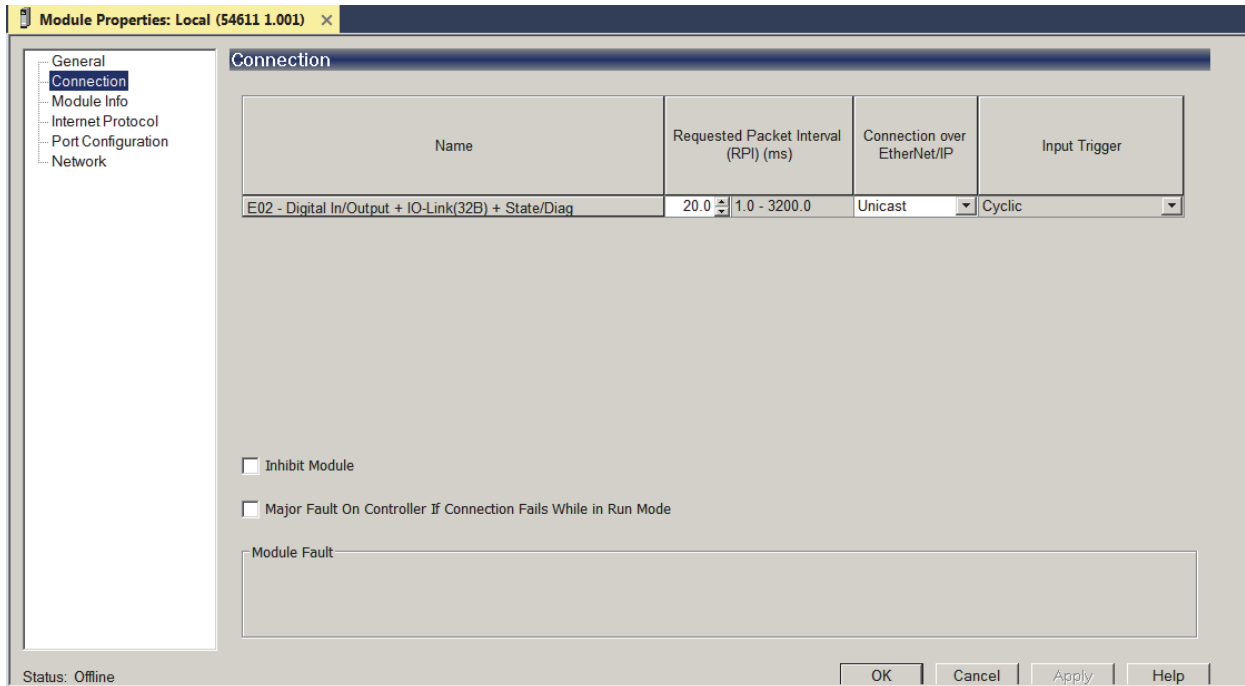

Fig. 8-5: Setting the RPI values

- ➔ Click the **Connection** tab.
- ➔ Set the desired RPI values in the column **Requested Packet Interval (RPI) (ms)**.



NOTICE
The minimum RPI is 1 ms.

8.4 Device Level Ring (DLR) configuration

Device Level Ring (DLR) is a protocol which allows a ring topology with EtherNet/IP devices. The ring network consists of at least one ring supervisor and any desired number of users. To build up the topology and to detect cable breaks inside the ring, there are two different methods:

- 1 | Beacon-based
- 2 | Announce-based

Prerequisites for configuration and diagnostic:

- Users support the DLR
- The DLR object (0x47) is implemented by the user.

The use of modules which are not DLR-compliant in an EtherNet/IP ring network is not excluded but results in a higher ring recovery time when the ring topology is interrupted.



NOTICE

The modules described in this manual support the beacon-based DLR technology.

8.5 IO-Link configuration

IO-Link configuration

With the IMPACT67 Pro E DIO8 IOL8 M12L 5P module, the IO-Link devices can be configured and parameterized in two different ways:

- 1 | IO-Link device configuration Explicit Messages in EtherNet/IP
- 2 | Murrelektronik IO-Link Device Tool

IO-Link device configuration through EtherNet/IP Explicit Messages

It is possible to parameterize the connected IO-Link devices through EtherNet/IP Explicit Messages.



For further information, please refer to chapter 9.2.1 "Diagnostics structure in the control system"

Murrelektronik IO-Link Device Tool

The **Murrelektronik IO-Link Device Tool** enables parameterization of IO-Link devices.

A hardware catalog is displayed via a graphical interface.

This is where you can assign and set an IO-Link device for the IMPACT67 Pro E DIO8 IOL8 M12L 5P IO-Link port.

The parameterization can then be sent to the IO-Link device.

8.6 Industrial Internet of Things (IIoT)

8.6.1 JSON

General JSON settings

No.	REST API URL	Description	Support- ed
1	GET /iolink/v1/gateway/identification	Identification of the gateway	✓
2	GET /iolink/v1/gateway/capabilities	Capabilities of the gateway	✓
3	GET /iolink/v1/gateway/configuration	Read network configuration of the gateway	✓
4	POST /iolink/v1/gateway/configuration	Write network configuration of the gateway	-
5	POST /iolink/v1/gateway/reset	Reset the gateway including all masters	-
6	POST /iolink/v1/gateway/reboot	Reboot the gateway including all masters	-
7	GET /iolink/v1/gateway/events	Event log containing all events from gateway, masters, ports, and devices	-
8	GET /iolink/v1/masters	Get all available master number keys and identification information	✓
9	GET /iolink/v1/masters/\$MASTER_NUMBER/capabilities	Capabilities of the master	✓
10	GET /iolink/v1/masters/\$MASTER_NUMBER/identification	Read identification of the master	✓
11	POST /iolink/v1/masters/\$MASTER_NUMBER/identification	Write identification of the master	-
12	GET /iolink/v1/masters/\$MASTER_NUMBER/ports	Get all available port number keys	✓
13	GET /iolink/v1/masters/\$MASTER_NUMBER/ports/\$PORT_NUMBER/capabilities	Read capability information of the specified port	✓
14	GET /iolink/v1/masters/\$MASTER_NUMBER/ports/\$PORT_NUMBER/status	Read status of the master	✓
15	GET /iolink/v1/masters/\$MASTER_NUMBER/ports/\$PORT_NUMBER/configuration	Read configuration of the specified port	✓
16	POST /iolink/v1/masters/\$MASTER_NUMBER/ports/\$PORT_NUMBER/configuration	Write configuration of the specified port	✓
17	GET /iolink/v1/masters/\$MASTER_NUMBER/ports/\$PORT_NUMBER/datastorage	Read data storage content of the specified port	-
18	POST /iolink/v1/masters/\$MASTER_NUMBER/ports/\$PORT_NUMBER/datastorage	Write data storage content of the specified port	-
19	GET /iolink/v1/devices	Address all devices of all masters	✓
20	GET /iolink/v1/devices/{deviceAlias}/capabilities	Read capability information of the specified device	-
21	GET /iolink/v1/devices/{deviceAlias}/identification	Read identification information of the specified device	✓
22	POST /iolink/v1/devices/{deviceAlias}/identification	Write identification information of the specified device	-
23	GET /iolink/v1/devices/{deviceAlias}/processdata/value?format=byteArray	Read process data value from the specified device	✓
24	GET /iolink/v1/devices/{deviceAlias}/processdata/getdata/value?format=byteArray	Read process data input value from the specified device	✓
25	GET /iolink/v1/devices/{deviceAlias}/processdata/setdata/value?format=byteArray	Read process data output value from the specified device	✓
26	POST /iolink/v1/devices/{deviceAlias}/processdata/value	Write the process data output value to the specified device	-
27	GET /iolink/v1/devices/{deviceAlias}/parameters/{index}/value/?format=byteArray	Read a specific parameter value and its sub-parameter values (if the parameter has complex type) with the given index of the device	-
28	GET /iolink/v1/devices/{deviceAlias}/parameters/{index}/subindices/{subindex}/value/?format=byteArray	Read the value of a specific sub-parameter with the given index and subindex	-

No.	REST API URL	Description	Supported
29	GET /iolink/v1/devices/{deviceAlias}/parameters/{parameterName}/value/?format=byteArray	Read a specific parameter value with the given name	-
30	POST /iolink/v1/devices/{deviceAlias}/parameters/{index}/value	Write the parameter with the given index to the device	-
31	POST /iolink/v1/devices/{deviceAlias}/parameters/{parameterName}/value	Write the parameter with the given name to the device	-
32	POST /iolink/v1/devices/{deviceAlias}/parameters/{index}/subindices/{subindex}/value	Write the sub-parameter with the given index and subindex to the device	-
33	POST /iolink/v1/devices/{deviceAlias}/parameters/{parameterName}/subindices/{subParameterName}/value	Write the sub-parameter with the given parameter name and sub-parameter name to the device	-
34	POST /iolink/v1/devices/{deviceAlias}/blockparametrization/?format=byteArray	Read or write one or more parameters as a block	-
35	GET /iolink/v1/devices/{deviceAlias}/events	Read event log from the specified device	<input checked="" type="checkbox"/>
36	GET /iolink/v1/mqtt/configuration	Read configuration of MQTT clients	<input checked="" type="checkbox"/>
37	POST /iolink/v1/mqtt/configuration	Write configuration of MQTT clients	-
38	GET /iolink/v1/mqtt/topics	Read list of MQTT topics	-
39	POST /iolink/v1/mqtt/topics	Write list of MQTT topics	-
40	DELETE /iolink/v1/mqtt/topics/{topicID}	Delete a specific MQTT topic	-
41	GET /iolink/v1/mqtt/topics/{topicID}	Read a specific MQTT topic	-
42	GET /iolink/v1/mqtt/connectionstatus	Read connection status	<input checked="" type="checkbox"/>

Vendor-specific JSON settings

No.	REST API URL	Description	Supported
43	GET /iolink/v1/vendor/masters/\$MASTER_NUMBER/diagnostics/configuration	Diagnostic configuration of the master	<input checked="" type="checkbox"/>
44	GET /iolink/v1/vendor/masters/\$MASTER_NUMBER/diagnostics/value	Diagnostic values of the master	<input checked="" type="checkbox"/>
45	GET /iolink/v1/vendor/masters/\$MASTER_NUMBER/ports/\$PORT_NUMBER/statistics/current	Current statistic values of the specified port of IO-Link master	<input checked="" type="checkbox"/>
46	GET /iolink/v1/vendor/masters/\$MASTER_NUMBER/ports/\$PORT_NUMBER/statistics/voltage	Voltage statistic values of the specified port of the master	<input checked="" type="checkbox"/>
47	GET /iolink/v1/vendor/masters/\$MASTER_NUMBER/ports/\$PORT_NUMBER/statistics/temperature	Temperature statistic values of the specified port of the master	<input checked="" type="checkbox"/>
48	GET /iolink/v1/vendor/masters/1/ports/1/statistics/stack	IO-Link stack statistic values of the specified port of the master	-
49	GET /iolink/v1/vendor/masters/\$MASTER_NUMBER/ports/\$PORT_NUMBER/diagnostics/configuration	Diagnostic configuration of the specified port of the master	<input checked="" type="checkbox"/>
50	GET /iolink/v1/vendor/masters/\$MASTER_NUMBER/ports/\$PORT_NUMBER/diagnostics/current	Diagnostic current value of the specified port of the master	<input checked="" type="checkbox"/>
51	GET /iolink/v1/vendor/masters/\$MASTER_NUMBER/ports/\$PORT_NUMBER/diagnostics/voltage	Diagnostic voltage value of the specified port of the master	<input checked="" type="checkbox"/>
52	GET /iolink/v1/vendor/masters/\$MASTER_NUMBER/ports/\$PORT_NUMBER/diagnostics/temperature	Diagnostic temperature value of the specified port of the master	<input checked="" type="checkbox"/>

8.6.2 MQTT



If MQTT is enabled, the activation of JSON is required.

MQTT settings

No.	MQTT topics	Description
1	\$MQTT_CLIENT_HEAD_TOPIC /iolink/v1/gateway/identification	Identification of the gateway
2	\$MQTT_CLIENT_HEAD_TOPIC /iolink/v1/gateway/capabilities	Capabilities of the gateway
3	\$MQTT_CLIENT_HEAD_TOPIC /iolink/v1/gateway/configuration	Network configuration of the gateway
4	\$MQTT_CLIENT_HEAD_TOPIC /iolink/v1/masters	Get all available master number keys and identification information
5	\$MQTT_CLIENT_HEAD_TOPIC /iolink/v1/masters/\$MASTER_NUMBER/diagnostics/value	Diagnostic values of the master
6	\$MQTT_CLIENT_HEAD_TOPIC /iolink/v1/masters/\$MASTER_NUMBER/diagnostics/configuration	Diagnostic configuration of the master
7	\$MQTT_CLIENT_HEAD_TOPIC /iolink/v1/masters/\$MASTER_NUMBER/capabilities	Capabilities of the master
8	\$MQTT_CLIENT_HEAD_TOPIC /iolink/v1/masters/\$MASTER_NUMBER/identification	Identification of the master
9	\$MQTT_CLIENT_HEAD_TOPIC /iolink/v1/masters/\$MASTER_NUMBER/ports	Get all available port number keys
10	\$MQTT_CLIENT_HEAD_TOPIC /iolink/v1/masters/\$MASTER_NUMBER/ports/\$PORT_NUMBER/capabilities	Read capability information of the specified port
11	\$MQTT_CLIENT_HEAD_TOPIC /iolink/v1/masters/\$MASTER_NUMBER/ports/\$PORT_NUMBER/status	Read actual status of the specified port
12	\$MQTT_CLIENT_HEAD_TOPIC /iolink/v1/masters/\$MASTER_NUMBER/ports/\$PORT_NUMBER/configuration	Read/Write configuration of the specified port
13	\$MQTT_CLIENT_HEAD_TOPIC /iolink/v1/masters/\$MASTER_NUMBER/ports/\$PORT_NUMBER/diagnostics/configuration	Diagnostic configuration of the specified port of the master
14	\$MQTT_CLIENT_HEAD_TOPIC /iolink/v1/masters/\$MASTER_NUMBER/ports/\$PORT_NUMBER/diagnostics/current	Diagnostic current value of the specified port of the master
15	\$MQTT_CLIENT_HEAD_TOPIC /iolink/v1/masters/\$MASTER_NUMBER/ports/\$PORT_NUMBER/diagnostics/voltage	Diagnostic voltage value of the specified port of the master
16	\$MQTT_CLIENT_HEAD_TOPIC /iolink/v1/masters/\$MASTER_NUMBER/ports/\$PORT_NUMBER/diagnostics/temperature	Diagnostic temperature value of the specified port of the master
17	\$MQTT_CLIENT_HEAD_TOPIC /iolink/v1/masters/\$MASTER_NUMBER/ports/\$PORT_NUMBER/statistics/current	Current statistic values of the specified port of the master
18	\$MQTT_CLIENT_HEAD_TOPIC /iolink/v1/masters/\$MASTER_NUMBER/ports/\$PORT_NUMBER/statistics/voltage	Voltage statistic values of the specified port of the master
19	\$MQTT_CLIENT_HEAD_TOPIC /iolink/v1/masters/\$MASTER_NUMBER/ports/\$PORT_NUMBER/statistics/temperature	Temperature statistic values of the specified port of the master
20	\$MQTT_CLIENT_HEAD_TOPIC /iolink/v1/devices/\$DEVICE_ALIAS/processdata/value	Read/Write process data value from/to the specified device
21	\$MQTT_CLIENT_HEAD_TOPIC /iolink/v1/devices/\$DEVICE_ALIAS/processdata/getdata/value	Read process data input value from the specified device
22	\$MQTT_CLIENT_HEAD_TOPIC /iolink/v1/devices/\$DEVICE_ALIAS/processdata/setdata/value	Read process data output value from the specified device
23	\$MQTT_CLIENT_HEAD_TOPIC /iolink/v1/devices/\$DEVICE_ALIAS/events	Read event log from the specified device
24	\$MQTT_CLIENT_HEAD_TOPIC /Asset	Information about the publisher (network, vendor, firmware)

No.	MQTT topics	Description
25	\$MQTT_CLIENT_HEAD_TOPIC /Online	Status of the publisher (online when connected)

8.6.3 OPC UA

8.6.3.1 Device identification

Nodes for the device identification are provided by the device. The OPC UA client, for example, can read the version of the device firmware from the Software Revision node.

Node name	Node class	Access	Description
Manufacturer	Variable	Read	Device manufacturer
ManufacturerUrl	Variable	Read	URL of the device manufacturer
Model	Variable	Read	Model name of the device
ProductCode	Variable	Read	Product code of the device
RevisionCounter	Variable	Read	Hardware revision of the device
SerialNumber	Variable	Read	Serial number of the device
SoftwareRevision	Variable	Read	Revision/version of the device firmware

Tab. 8-1: Device identification

8.6.3.2 Process data

The OPC UA server provides nodes with process data. In the node Pin2ProcessData, the OPC UA client can, for example, read the value at pin 2 of a port.

Node name	Node class	Access	Description
Pin2ProcessData	Variable	Read	Process data at pin 2
Pin4ProcessData	Variable	Read	Process data at pin 4

Tab. 8-2: Process data

8.6.3.3 Configuration parameters

The OPC UA server provides nodes with configuration parameters of the module. In the node **OverTemperature**, the OPC UA server can, for example, read the upper limit value for the temperature.

Node name	Node class	Access	Default	Description
CurrentHysteresis	Variable	Read	10 mA	Current hysteresis, unit: mA If the current exceeds the limit value, the current must fall below the limit value by the hysteresis value in order to cancel the diagnostic.
OverTemperature	Variable	Read	70 °C	Upper limit value for the temperature of a port, unit: 0.1 °C
OverVoltageL	Variable	Read	30 V	Upper limit value for the voltage in the supply line 1, pins with the function L+, DI, DO, DIO, IO-Link can be monitored, unit: mV
OverVoltageL2	Variable	Read	30 V	Upper limit value for the voltage in the supply line 2, unit: mV
TemperatureHysteresis	Variable	Read	2 °C	Temperature hysteresis, unit: 0.1 °C If the temperature exceeds the limit value, the temperature must fall below the limit value by the hysteresis value in order to cancel the diagnostic.
UnderTemperature	Variable	Read	-25 °C	Lower limit value for the temperature of a port, unit: 0.1 °C
UnderVoltage L	Variable	Read	18 V	Lower limit value for the voltage in the supply line 1, pins with the function L+, DI, DO, DIO, IO-Link can be monitored, unit: mV

Node name	Node class	Access	Default	Description
UnderVoltage L2	Variable	Read	18 V	Lower limit value for the voltage in the supply line 2, unit: mV
Voltage Hysteresis	Variable	Read	300 mV	Voltage hysteresis, unit: mV If the voltage exceeds the limit value, the voltage must fall below the limit value by the hysteresis value in order to cancel the diagnostic.
OverCurrentPin1, OverCurrentPin2, OverCurrentPin4	Variable	Read	0	Warning level for upper current limit at pin 1, pin 2 or pin 4, unit: 1mA 0: Monitoring not activated
UnderCurrentPin1, UnderCurrentPin2, UnderCurrentPin4	Variable	Read	0	Warning level for lower current limit at pin 1, pin 2 or pin 4, unit: 1mA 0: Monitoring not activated

Tab. 8-3: Device-specific configuration parameters

8.6.3.4 Measured values

The OPC UA server provides nodes with calculated results. The OPC UA client, for example, can read in the node SumCurrentL the calculated total current of the supply line 1.

Node name	Node class	Access	Description
SumCurrentL	Variable	Read	The total current calculated from individual measurements in the supply line 1, unit: mA
SumCurrentL2	Variable	Read	The total current calculated from individual measurements in the supply line 2, unit: mA
MeanTemperature	Variable	Read	Average value for the temperature of the subassembly calculated from the temperature values measured individually at the three chips, unit: °C
MeanVoltageL	Variable	Read	Average voltage in the supply line 1, unit: mV
MeanVoltageL2	Variable	Read	Average voltage in the supply line 2, unit: mV

Tab. 8-4: Device-specific (calculated) results

Node name	Node class	Access	Description
CurrentPin1, CurrentPin2, CurrentPin4	Variable	Read	Current measured at pin 1, pin 2 or pin 4, unit: mA
TemperaturePin1, TemperaturePin2, TemperaturePin4	Variable	Read	Temperature measured at pin 1, pin 2 or pin 4, unit: °C
VoltagePin1, VoltagePin2, VoltagePin4	Variable	Read	Voltage measured at pin 1, pin 2 or pin 4, unit: mA

Tab. 8-5: Port-specific measuring values

8.6.3.5 Diagnostic

The OPC UA server provides nodes with diagnostic information. In the node DiagnosticsPin1, the OPC UA client can read, for example, whether the module has detected an overcurrent at pin 1 of a port.

Node name	Node class	Access	Description
DiagnosticsPin1, DiagnosticsPin2, DiagnosticsPin4	Variable	Read	Diagnostic at pin 1, pin 2 or pin 4. The numeric value contains bit-coded information: <ul style="list-style-type: none"> ■ Bit 0: Short circuit, ■ Bit 1: Overload protection, ■ Bit 2: Excess temperature protection, ■ Bit 3: Overvoltage protection, ■ Bit 4: Overcurrent, ■ Bit 5: Undercurrent ■ Bit 0: Excess temperature ■ Bit 1: Undertemperature ■ Bit 2: Overvoltage ■ Bit 3: Undervoltage ■ Bit 4: Watchdog 0: Diagnostic not active 1: Diagnostic active

Tab. 8-6: Port-specific diagnostics

8.6.3.6 Statistics

The OPC UA server provides nodes with statistical information. In the node MaxCurrentPin1, the OPC UA client can, for example, read the maximum measured current at pin 1 of a port.

Node name	Node class	Access	Description
MaxCurrentPin1, MaxCurrentPin2, MaxCurrentPin4	Variable	Read	Maximum current at pin 1, pin 2 or pin 4 since reset of the value, unit: mA
MinCurrentPin1, MinCurrentPin2, MinCurrentPin4	Variable	Read	Minimum current at pin 1, pin 2 or pin 4 since reset of the value, unit: mA
MaxTemperaturePin1, MaxTemperaturePin2, MaxTemperaturePin4	Variable	Read	Maximum temperature at pin 1, pin 2 or pin 4 since reset of the value, unit: °C
MinTemperaturePin1, MinTemperaturePin2, MinTemperaturePin4	Variable	Read	Minimum temperature at pin 1, pin 2 or pin 4 since reset of the value, unit: °C
MaxVoltagePin1, MaxVoltagePin2, MaxVoltagePin4	Variable	Read	Maximum voltage at pin 1, pin 2 or pin 4 since reset of the value, unit: mV
MinVoltagePin1, MinVoltagePin2, MinVoltagePin4	Variable	Read	Minimum voltage at pin 1, pin 2 or pin 4 since reset of the value, unit: mV

Tab. 8-7: Port-specific statistical information

9 Operation

9.1 LED indication

The module has separate and clearly arranged indicators:

- LED indication for inputs and outputs
- LED indication for bus
- LED indication POWER
- Extended LED indications

The LEDs on the front panel of the module are labeled for clear identification of the displayed information.

9.1.1 LED assignment to channel and pin

A separate status display is assigned to each input and output.

- LED of channel **0X** (X=port number) is assigned to **pin 4**.
- LED of channel **1X** (X=port number) is assigned to **pin 2**.

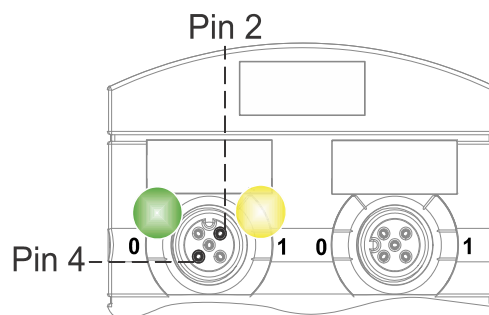

9.1.2 LED flashing behavior

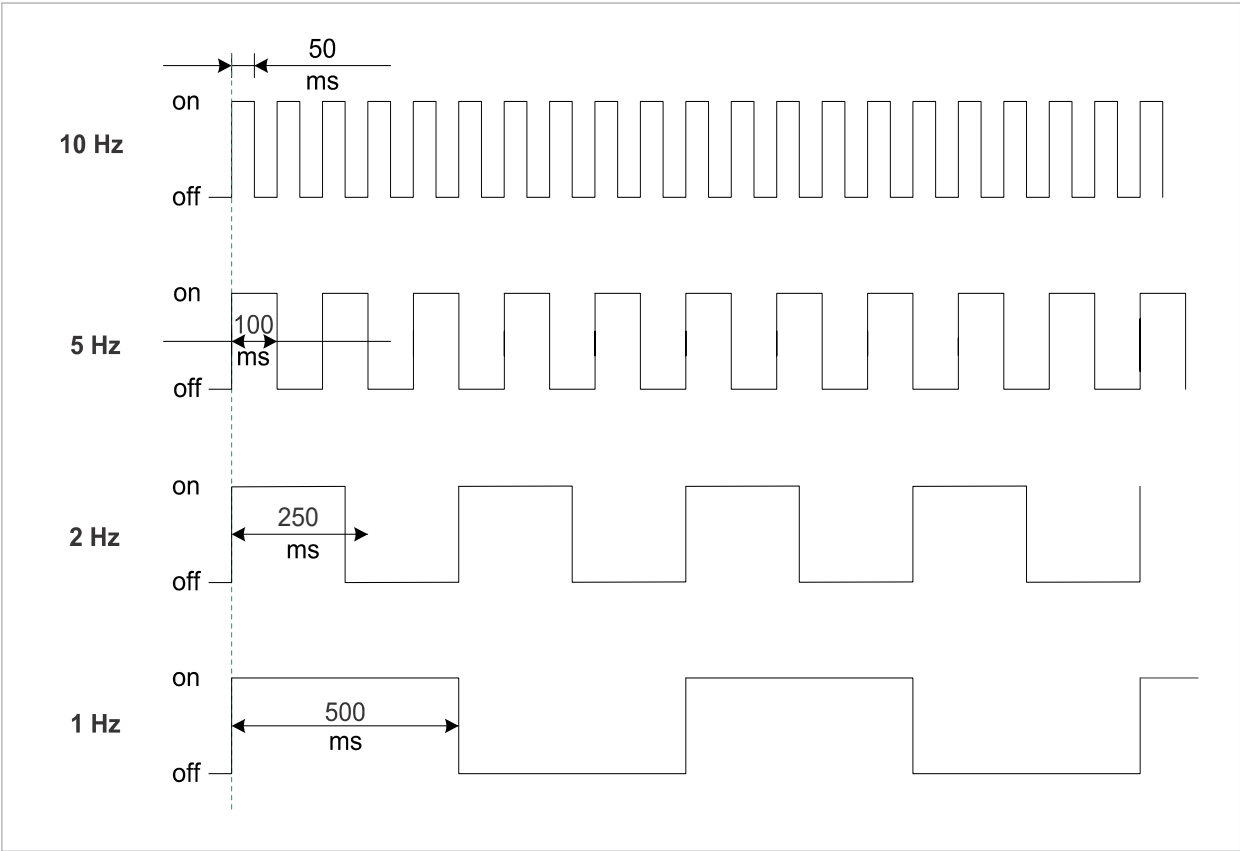
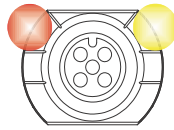





Fig. 9-1: LED flashing behavior

9.1.3 LED indication for inputs and outputs







A separate status display is assigned to each input and output.

Pin 2 Digital input DI

Indication	Condition	Description
 Yellow	Permanently on	Fixed configuration: DI (NO) visible in process data. 24 V
 Red	Flashing at 1 Hz	Overload/ short circuit in sensor supply 24 V + Pin1
 Off	Off	Pin 2 is not used or deactivated

Tab. 9-1: LED indication DI pin 2

Pin 2 Digital output DO



Indication	Condition	Description
 Yellow	Permanently on	Fixed configuration: DO switchable via process data 24 V
 Red	Permanently on	Overload/ short-circuit at pin 2
 Red	Flashing at 1 Hz	Overload/ short circuit in sensor supply 24 V + Pin1
 Off	Off	Pin 2 is not used or deactivated

Tab. 9-2: LED indication DO pin 2

Error at input or output





If an error occurs at an input or output, the associated LED at the M12 port lights up red.

Pin 4
Digital input DI

Indication	Condition	Description
 Yellow	Permanently on	Fixed configuration: DI (NO) visible in process data 24 V
 Red	Flashing at 1 Hz	Overload/ short circuit in sensor supply 24 V + Pin1
 Off	Off	Pin 4 is not used or deactivated







Tab. 9-3: LED indication DI pin 4

Pin 4
Digital output DO

Indication	Condition	Description
 Yellow	Permanently on	Fixed configuration: DO switchable via process data 24 V
 Red	Permanently on	Overload/ short-circuit at pin 4
 Red	Flashing at 1 Hz	Overload/ short circuit in sensor supply 24 V + Pin1
 Off	Off	Pin 4 is not used or deactivated

Tab. 9-4: LED indication DO pin 4

Pin 4
IO-Link mode

Indication	Condition	Description
 Green	Permanently on	IO-Link in Operate status.
 Green	Flashing at 1 Hz	- Module is not connected - No communication with the connected module.
 Green	Flashing at 10 Hz	- IO-Link in Pre-Operate status during data storage - Validation failed. Incompatible IO-Link module connected.
 Red	Permanently on	Overload/ short-circuit at pin 4
 Red	Flashing at 2 Hz	- Validation failed. - Incompatible IO-Link module connected for data storage. - Data storage failed.
 Off	Off	IO-Link connection deactivated.

Tab. 9-5: LED indication IO-Link mode pin 4





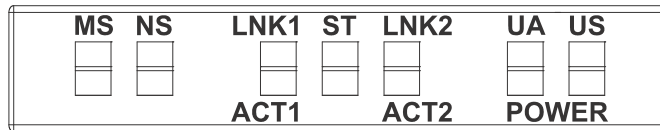

9.1.4 LED display MS and NS

LED-Indication Overview



- NS (network status) - indicates the state of the fieldbus system
- MS (module status) - indicates the state of the module in the PLC configuration

LED indication MS

Indication	Condition	Description
 Green	Permanently on	Module in operation
 Green	Flashing at 1 Hz	Standby: The module has not been configured.
 Green Red	Flashing at 1 Hz	Self-test
 Red	Flashing at 1 Hz	Major recoverable fault.*
 Red	Permanently on	Major unrecoverable fault.
 Off		No power supply.

Tab. 9-6: LED indication MS



LED display, red







* Major recoverable fault.

Incorrect or inconsistent configuration is considered a fatal correctable error.

This is what you can do:

- ➔ Check for IP address conflict.

LED indicator NS

Indication	Condition	Description
 Green	Permanently on	- Connection to the master available, - IP address is being configured.
 Green	Flashing at 1 Hz	- No connection to master. - IP address is configured.
 Green Red	Flashing at 1 Hz	Self-test
 Red	Flashing at 1 Hz	At least one connection has timed out.
 Red	Permanently on	Duplicate IP address: the module has detected that its IP address is already in use.
 Off		- No power supply, - no configured IP address.

Tab. 9-7: LED indicator NS

LED display, red

This is what you can do:

➔ Check for IP address conflict.

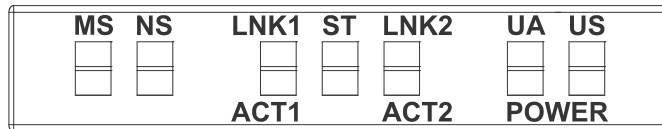

9.1.5 LED indication for LNK/ACT

LED-Indication Overview





- LNK/ACT (Link/Activity) indicate the state of the EtherCAT communication at each port.

LED indication LNK

LED indication	LED state	Description
 Green	Permanently on	Connection to network available.
 Off		No connection to network.

Tab. 9-8: LED indication LNK

LED indication ACT

LED indication	LED state	Description
 Yellow	Flashing	The module sends/receives Ethernet frames
 Off		The module does not send/receive Ethernet frames

Tab. 9-9: LED indication ACT

LED indication Off

This is what to do:

➔ Check the line connections.



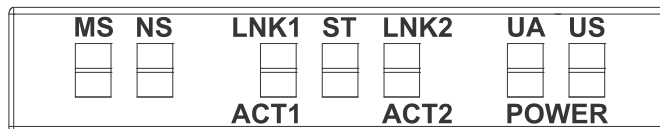

9.1.6 LED indication for state

LED-Indication Overview



■ ST - indicates the state of the overall module.

LED indicator ST

Indication	Condition	Description
 Green	Permanently on	The regular firmware is running. Normal operation.
 Green	Flashing at 4 Hz	The operation requested by the position of the rotary switch is performed. Do not switch off the device.
 Red	Flashing at 1 Hz	Invalid rotary switch position. The system does not start.
 Red	Permanently on	Initialization error. Error during module initialization. a HW problems, b missing valid configuration, c no COM FW found, d rotary switch operation failed, etc.

Tab. 9-10: LED indicator ST

9.1.7 LED indicator POWER US and UA



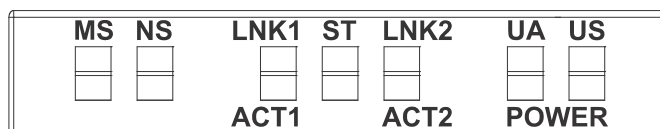

LED-Indication Overview



The power LEDs indicate the state of the supply voltages

- **UA** actuator voltage
- **US** operating voltage

**LED indicator
POWER US**

Indica- tion	Condition	Description
 Green	Permanently on	18 V ≤ US ≤ 30 V Error-free operation
 Red	Permanently on	11 V ≤ US ≤ 18 V Undervoltage
 Red	Flashing at 4 Hz	US > 30 V Overvoltage
 Off	Off	US < 11 V No voltage





Tab. 9-11: LED indicator POWER US



NOTE

At US < 18 V, an error-free operation is no longer guaranteed.

**LED indicator
POWER UA**

Indica- tion	Condition	Description
 Green	Permanently on	18 V ≤ UA ≤ 30 V Error-free operation
 Red	Permanently on	11 V ≤ UA ≤ 18 V Undervoltage
 Red	Flashing at 4 Hz	UA > 30 V Overvoltage
 Off	Off	UA < 11 V No voltage

Tab. 9-12: LED indicator POWER UA

9.1.8 Extended LED indication

**LED-Indication
Overview**

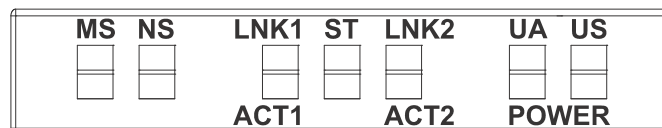



Extended LED display, identification of the module

LED	Indication	Condition	Description
MS NS ST POWER UA POWER US	 Green	Flashing 1 Hz	Identification of the module





Tab. 9-13: Extended LED display, identification of the module.

Extended LED Indication Update

LED	Indication	State	Description
MS NS ST POWER UA POWER US	 Yellow	Cascading sequential light	Update is being transmitted
	 Red		Update flashes





Tab. 9-14: Extended LED Indication, update

Extended LED display, update

LED	Indication	Condition	Description
MS POWER UA POWER US	 Yellow	Flashing alternately 1 Hz	Update check in progress
	 Red	Rapid flashing	Update flashing interrupted
	 Red	Flashing alternately 1 Hz	Update failed
ST	 Off		



Tab. 9-15: Extended LED display, update

Extended LED indication Factory reset

LED	Indication	Condition	Description
MS NS POWER UA POWER US	 Green	Left and right sides are flashing alternately at 1 Hz	Factory reset has been completed successfully
	 Yellow	Left and right sides are flashing alternately at 1 Hz	Factory reset in progress
	 Red	Left and right sides are flashing alternately at 1 Hz	Factory reset has been completed with failure
ST	 Off		





Tab. 9-16: Extended LED indication, factory reset

**Extended LED Indication
recovery firmware:
system startup**

LED	Indication	State	Description
ST	 Yellow	Double flash	Recovery firmware: system startup
BUS_NS POWER UA POWER US	 Off		





Tab. 9-17: Extended LED Indication, recovery firmware: system startup

**Extended LED Indication
recovery firmware:
system initialization**

LED	Indication	State	Description
NS	 Green	Lights continuously	
ST	 Yellow	Double flash	Recovery firmware: system initialization
MS	 Yellow	Flashing 1 Hz	
POWER UA POWER US	 Off		



Tab. 9-18: Extended LED states, recovery firmware: system initialization

**Extended LED Indication
recovery firmware: system run**

LED	Indication	State	Description
MS	 Green	Lights continuously	
ST	 Yellow	Double flash	Recovery firmware: system run
POWER UA	 Yellow	Flashing 1 Hz	
POWER US	 Off		







Tab. 9-19: Extended LED Indication, recovery firmware: system run

Extended LED Indication
Firmware update:
initialization of transmission

LED	Indication	State	Description
MS POWER UA	 Green	Lights continuously	
ST	 Yellow	Double flash	Firmware update: initialization of transmission
POWER US	 Yellow	Flashing 1 Hz	

Tab. 9-20: Extended LED Indication, firmware update: initialization of transmission

Extended LED Indication
Firmware update

LED	Indication	State	Description
ST	 Yellow	Double flash	
MS POWER UA POWER US	 Yellow	Cascading sequential light	The new firmware is being transmitted
	 Yellow	Flashing alternately 1 Hz	The new firmware is being checked
	 Red	Cascading sequential light	The new firmware is being updated
	 Red	Single flash	Writing has been aborted
	 Red	Flashing alternately 1 Hz	Updating the firmware failed

Tab. 9-21: Extended LED Indication, firmware update

9.2 Diagnostics

9.2.1 Diagnostics structure in the control system

Byte	Description	Value
0	Last octet of the IP-address of the device	Last octet of the IP-address of the device
1	IO-Link identification	0 = Default Code 0x40 = IO-Link Master Event Code 0x41 = IO-Link Device Event Code 0x42 = Murrelektronik IO-Link Device Event Code
2	Master channel number where the error occurred	
3	Device channel number where the error occurred	Only available if the IO-Link identification (Byte1) is set to the value 0x42
4	ErrorCode Byte1	For IO-Link, this is the LSB of the IO-Link ErrorCode, otherwise it is the Global Error Code, see Tab. 9-22: "Short-circuit diagnostic (Global Error Code 0x01)".
5	ErrorCode Byte2	For IO-Link, this is the MSB of the IO-Link ErrorCode, otherwise it is the Specific Error Code, see Tab. 9-22: "Short-circuit diagnostic (Global Error Code 0x01)".
6	Severity and active/inactive display	Bit 0: ■ 0 = Inactive diagnostic ■ 1 = Active diagnostic Bit 6 and 7: ■ 1 = Minor fault ■ 2 = Major fault ■ 3 = Information
7	Reserved	0

9.2.2 Diagnostics in the web server



Diagnostic monitoring The module diagnostics may also be monitored using the diagnostic page of the integrated web server.

Representation Module status is displayed as the text descriptions in the tables below:

1| **Key**: indicates the type of diagnostic

2| **Description**: shows a more detailed description of the error

3| **Severity**: distinguishes 3 error categories

- a) **Information** 
- b) **Warning** 
- c) **Defect** 

4| **Type**: this shows whether the diagnostic has just occurred or the fault has already been eliminated.

There are two types of diagnostics.

- Active** 
- Inactive** 

9.2.3 Diagnostic value

9.2.3.1 Short-circuit diagnostic

Global Error Code 0x01

Description	Value
Sensor Short Circuit	0x01
Actuator Warning	0x17
Actuator Short Circuit	0x18

Tab. 9-22: Short-circuit diagnostic (Global Error Code 0x01)

9.2.3.2 Undervoltage diagnostic

Global Error Code 0x02

Description	Value
Undervoltage Actuator Power Supply	0x28
No Voltage Actuator Power Supply	0x29
Undervoltage External Actuator Power Supply	0x2A
No Voltage External Actuator Power Supply	0x2B
Undervoltage Sensor Power Supply	0x32
No Voltage Sensor Power Supply	0x33
Undervoltage U1	0xD0
Undervoltage U2	0xD1

Tab. 9-23: Undervoltage diagnostic (Global Error Code 0x02)

9.2.3.3 Overvoltage diagnostic

Global Error Code 0x03

Description	Value
Overvoltage Actuator Power Supply	0x2C
Overvoltage External Actuator Power Supply	0x2D
Overvoltage Sensor Power Supply	0x34
Overvoltage U1	0xD4
Overvoltage U2	0xD5

Tab. 9-24: Overvoltage diagnostic (Global Error Code 0x03)

9.2.3.4 General diagnostic

Global Error Code 0x09

Description	Value
Error	0x00
PLC Connection Of Exclusive Owner Timed Out	0x59

Tab. 9-25: General diagnostic (Global Error Code 0x09)

9.2.3.5 Buffer overflow diagnostic

Global Error Code 0xFF

Description	Value
Overflow	0xFF

Tab. 9-26: Buffer Overflow Diagnostic (Global Error Code 0xFF)

9.2.3.6 IO-Link master diagnostic

IO-Link identification 0x40

Description	Value
Error	0x0000
Error Fetching Extended Events	0x97FF
Startup Parameterization Error	0x9801
Wrong Device. Inspection Level Mismatch	0x9802
Process Data Mismatch	0x9803
Short Circuit At C/Q - Pin 4	0x9804
IO-Link PHY Overtemperature	0x9805
Short Circuit L+ - Pin1	0x9806
Undervoltage L+ - Pin1	0x9807
Device Event Overflow	0x9808
Backup Failed - Memory Out Of Range 2k	0x9809
Backup Inconsistency - Data Storage Index Not Available	0x980A
Backup Inconsistency - Data Storage Unspecific Error	0x980B
Backup Inconsistency - Upload Fault	0x980C
Parameter Inconsistency - Download Fault	0x980D
Port Class B Failure - Power Missing	0x980E
Short Circuit At Pin 2	0x980F
Revision Fault	0x9811
Compatibility Fault Vendor ID (IO-Link 1.0)	0x9812
Compatibility Fault Device ID (IO-Link 1.0)	0x9813
Compatibility Fault Vendor ID (IO-Link 1.1)	0x9814
Compatibility Fault Device ID (IO-Link 1.1)	0x9815
Serial Number Fault	0x9816
Generic Data Storage Fault	0x9817
Invalid Cycle Time	0xE000
Revision Fault- Incompatible Protocol Version	0xE001
Parameter Inconsistency - ISDU Batch Failed	0xE002
Device Not Available - Communication Lost	0xFF22
Invalid Backup - Data Storage Identification Mismatch	0xFF23
Invalid Backup - Data Storage Buffer Overflow	0xFF24
Invalid Backup - Data Storage Parameter Access Denied	0xFF25
Event Lost - Incorrect Event Signaling	0xFF31

Tab. 9-27: IO-Link master diagnostic (IO-Link identification 0x40)

9.2.3.7 IO-Link device diagnostic

IO-Link identification 0x41

Description	Value
Error	0x0000
General Malfunction	0x1000
Temperature Fault	0x4000
Ambient Temperature: General Error	0x4100
Ambient Temperature: Over-Run	0x4110
Ambient Temperature: Under-Run	0x4120
Device Temperature: General Error	0x4200
Device Temperature: Over-Run	0x4210
Device Temperature: Under-Run	0x4220
Outside Temperature: General Error	0x4300
Outside Temperature: Over-Run	0x4310
Outside Temperature: Under-Run	0x4320
Device Hardware Fault	0x5000
Component Malfunction	0x5010
Non Volatile Memory Loss	0x5011
Batteries Low	0x5012
General Power Supply Fault	0x5100
Fuse Blown/Open	0x5101
Primary Supply Voltage Over-Run	0x5110
Primary Supply Voltage Under-Run	0x5111
Secondary Supply Voltage Fault	0x5112
Device Supply: Voltage Under-Run U3	0x5113
Device Supply: Voltage Under-Run U4	0x5114
Device Supply: Voltage Under-Run U5	0x5115
Device Supply: Voltage Under-Run U6	0x5116
Device Supply: Voltage Under-Run U7	0x5117
Device Supply: Voltage Under-Run U8	0x5118
Device Supply: Voltage Under-Run U9	0x5119
Device Supply: Short Circuit	0x5151
Device Supply: Error In Periphery	0x5160
Device Controller: General Error	0x5200
Device Control Section: General Error	0x5300
Device Power Section: General Error	0x5400
Device Power Section: Error In Output Driver	0x5410
Device Power Section: Fuse Blown/Open	0x5450
Device Power Section: Fuse Blown/Open S1	0x5451
Device Power Section: Fuse Blown/Open S2	0x5452
Device Power Section: Fuse Blown/Open S3	0x5453
Device Power Section: Fuse Blown/Open S4	0x5454
Device Power Section: Fuse Blown/Open S5	0x5455
Device Power Section: Fuse Blown/Open S6	0x5456
Device Power Section: Fuse Blown/Open S7	0x5457
Device Power Section: Fuse Blown/Open S8	0x5458
Device Power Section: Fuse Blown/Open S9	0x5459
Error In Additional Device Communication	0x5500
Error In Device Communication Interface 2	0x5510
Device Software Fault	0x6000
Device Software: Reset (Watchdog)	0x6010
Device Software: Internal Fault	0x6100
Device Software: Dataset Error	0x6300
Loss Of Parameter	0x6310

Description	Value
Parameter Error	0x6320
Parameter Missing	0x6321
Parameter Not Initialized	0x6330
Parameter Not Specific	0x6340
Parameter Changed	0x6350
Wire Break Of A Subordinate Device	0x7700
Wire Break Of Subordinate Device 1	0x7701
Wire Break Of Subordinate Device 2	0x7702
Wire Break Of Subordinate Device 3	0x7703
Wire Break Of Subordinate Device 4	0x7704
Wire Break Of Subordinate Device 5	0x7705
Wire Break Of Subordinate Device 6	0x7706
Wire Break Of Subordinate Device 7	0x7707
Wire Break Of Subordinate Device 8	0x7708
Wire Break Of Subordinate Device 9	0x7709
Wire Break Of Subordinate Device 10	0x770A
Wire Break Of Subordinate Device 11	0x770B
Wire Break Of Subordinate Device 12	0x770C
Wire Break Of Subordinate Device 13	0x770D
Wire Break Of Subordinate Device 14	0x770E
Wire Break Of Subordinate Device 15	0x770F
Short Circuit	0x7710
Ground Fault	0x7711
Communication Monitoring: General Error	0x8100
Process Data Monitoring: General Error	0x8110
Technology Specific Application Fault	0x8C00
Simulation Active	0x8C01
Process Variable Range Over-Run	0x8C10
Measurement Range Over-Run	0x8C20
Process Variable Range Under-Run	0x8C30
Maintenance Required - Cleaning	0x8C40
Maintenance Required - Refill	0x8C41
Maintenance Required - Wear And Tear	0x8C42

Tab. 9-28: IO-Link device diagnostic (IO-Link identification 0x41)

9.3 Acyclic IO-Link device access

IO-Link Device Parameter Object (Class Code 0x83)

The fieldbus device allows connected IO-Link devices to be configured with acyclic write and read access using the IO-Link Device Parameter Object (Class Code 0x83).

The IO-Link Device Parameter Object can be used to access parameters of an IO-Link device via ISDU (Index Service Data Unit). The object provides services that map CIP services to IO-Link services. An IO-Link port is addressed via the CIP instance of the “IO-Link Device Parameter Object”.

9.3.1 Reading an IO-Link device index

Read ISDU Request

Read IO-Link device index

- ➔ To read the index of a connected IO-Link device, use the EtherNet/IP service Read_ISDU 75 (0x4B).
- ➔ Send the service to the correct attribute of the IO-Link device parameter object (class code 0x83).
- ➔ An attribute represents the IO-Link port to which the IO-Link device is connected.

Structure of a read ISDU service request

Name	Value	Type	Description
CIP Service	75 (0x4B)	-	ISDU read service
CIP Class	131 (0x83)	-	IO-Link Device Parameter Object
CIP Instance	1 ... Number of available IO-Link Ports	-	Addresses the IO-Link Port the IO-Link device is connected to
CIP Data	Index	UINT	IO-Link ISDU object index
	Subindex	USINT	IO-Link ISDU object subindex

Tab. 9-29: Structure of a read ISDU service request

Read ISDU Response

Positive Response (CIP Status in service response == 0)

Name	Value	Type	Description
CIP Service	75 (0x4B)	-	ISDU read service
CIP Class	131 (0x83)	-	IO-Link Device Parameter Object
CIP Instance	1 ... Number of available IO-Link Ports	-	Addresses the IO-Link Port the IO-Link device is connected to
CIP Data	ISDU Data	ARRAY of BYTE	IO-Link object data retrieved from the IO-Link device. Maximum number of bytes: 0 - 232

Tab. 9-30: Positive Response (CIP Status in service response == 0)

Negative Response (CIP Status in service response != 0)

Name	Value	Type	Description
CIP Service	75 (0x4B)	-	ISDU read service
CIP Class	131 (0x83)	-	IO-Link Device Parameter Object
CIP Instance	1 ... Number of available IO-Link Ports	-	Addresses the IO-Link Port the IO-Link device is connected to
CIP Data	The structure of the error codes can be found in chapter 9.3.3 "CIP status codes"	UINT	IO-Link Master Error
		USINT	IO-Link Device Error
		USINT	IO-Link Device Additional Error

Tab. 9-31: Negative Response (CIP Status in service response != 0)

9.3.2 Writing an IO-Link device index

Write ISDU Request

Writing an IO-Link device index

- ➔ To write the index of a connected IO-Link device, use the EtherNet/IP service Write_ISDU 76 (0x4C).
- ➔ Send the service to the correct attribute of the IO-Link device parameter object (class code 0x83).
- ➔ An attribute represents the IO-Link port to which the IO-Link device is connected.

Structure of a write ISDU service request

Name	Value	Type	Description
CIP Service	76 (0x4C)	-	ISDU write service
CIP Class	131 (0x83)	-	IO-Link Device Parameter Object
CIP Instance	1 ... Number of available IO-Link Ports	-	Addresses the IO-Link Port the IO-Link device is connected to
CIP Data	Index	UINT	IO-Link ISDU object index
	Subindex	USINT	IO-Link ISDU object subindex
	Data	ARRAY of BYTE	Data that shall be written to IO-Link device. Maximum number of bytes: 0 - 232

Tab. 9-32: Structure of a write ISDU service request

Write ISDU Response

Positive Response (CIP Status in service response == 0)

The positive response to this service does not hold any CIP data.

Name	Value	Type	Description
CIP Service	76 (0x4C)	-	ISDU write service
CIP Class	131 (0x83)	-	IO-Link Device Parameter Object
CIP Instance	1 ... Number of available IO-Link Ports	-	Addresses the IO-Link Port the IO-Link device is connected to
CIP Data	The positive response to this service does not hold any CIP Data (Number of bytes: 0).		

Tab. 9-33: Positive Response (CIP Status in service response == 0)

Negative Response (CIP Status in service response != 0)

Name	Value	Type	Description
CIP Service	76 (0x4C)	-	ISDU write service
CIP Class	131 (0x83)	-	IO-Link Device Parameter Object
CIP Instance	1 ... Number of available IO-Link Ports	-	Addresses the IO-Link Port the IO-Link device is connected to
CIP Data	The structure of the error codes can be found in chapter 9.3.3 "CIP status codes"	UINT	IO-Link Master: Error code
		USINT	IO-Link Device: Error code
		USINT	IO-Link Device: Additional error code

Tab. 9-34: Structure of a write ISDU service request

9.3.3 CIP status codes

CIP error codes

The following table provides a brief overview of which CIP status code can be returned when accessing the "IO-Link Device Parameter Object" via a CIP service. The table does not claim to be complete.

CIP status	Description
0 (0x00)	Success. Service was successfully performed.
5 (0x05)	Path destination unknown. Addressed CIP Class or CIP Instance is not known.
8 (0x08)	Service not supported. The requested service is not implemented or was not defined for this Object Class/Instance.
19 (0x13)	Not enough data. The service did not supply enough data to perform the specified operation.
20 (0x14)	Attribute not supported. The attribute specified in the request is not supported.
21 (0x15)	Too much data. The service supplied more data than was expected.
30 (0x1E)	An embedded service resulted in an error. The IO-Link specific error codes within the CIP response data might provide more information about what went wrong.

Tab. 9-35: CIP status codes

10 Web server

The Murrelektronik web server is a graphic tool that you can use to obtain information about the device quickly and intuitively.

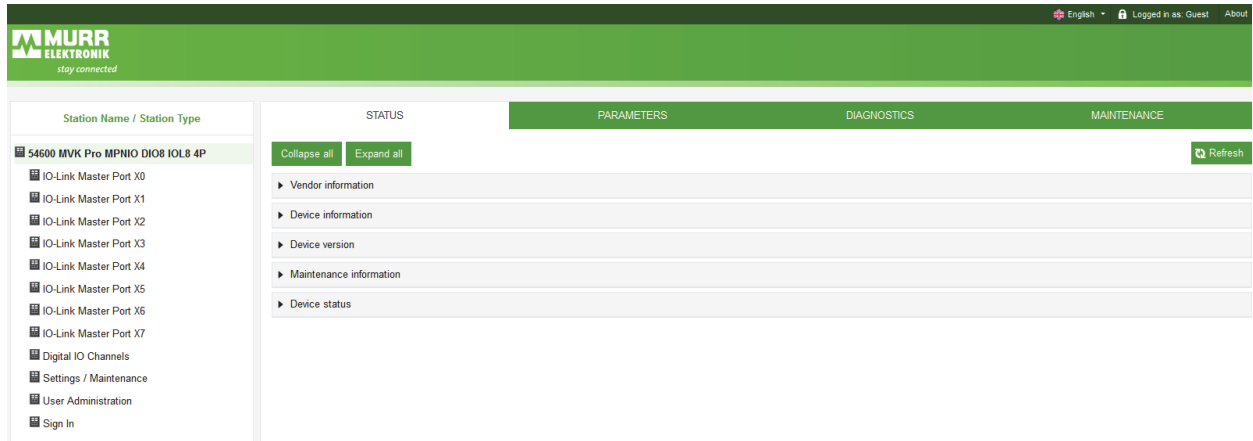

Fig. 10-1: The Murrelektronik web server

The devices shown in the screenshots serve as examples.



10.1 Starting the web server

Prerequisites

Prerequisite for a correct graphic display of the web server:

→ Current versions of the following browsers are supported:

- Mozilla Firefox
- Microsoft Edge
- Google Chrome

To start the web server, proceed as follows:

- Start the web browser.
- Enter the IP address of the device in the web browser.
The Webserver startup screen is the "Status" page.

Operating areas

The web server is divided into 4 operating areas.

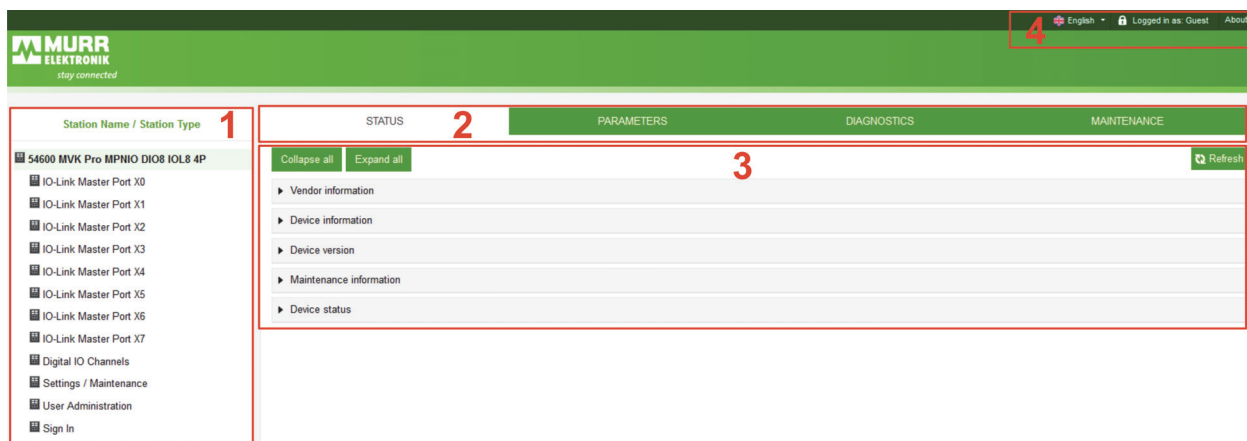

Fig. 10-2: Operating areas

- 1 | **System tree**
Shows the device and the available sub-functions.
- 2 | **Menu bar**
The menu bar enables you to switch between the different pages of the device or the sub-function. In addition, the white tab highlights the current page.
- 3 | **Page content**
This area shows the contents of the selected page.
- 4 | **Header bar**
Language and interface settings, system information.

10.2 Menu bar

In the first line of the system tree, the device is displayed with article number and product name.

The menu bar comprises the following clickable menu items:

- Status
- Parameters
- Diagnostic
- Maintenance

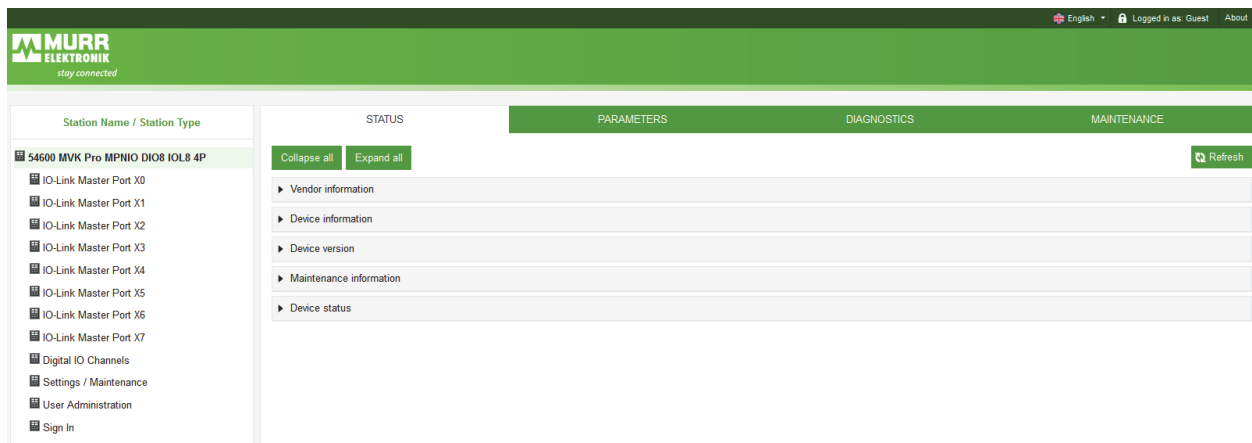

Fig. 10-3: Menu bar

10.2.1 STATUS menu

The “Status” menu item contains the following subitems:

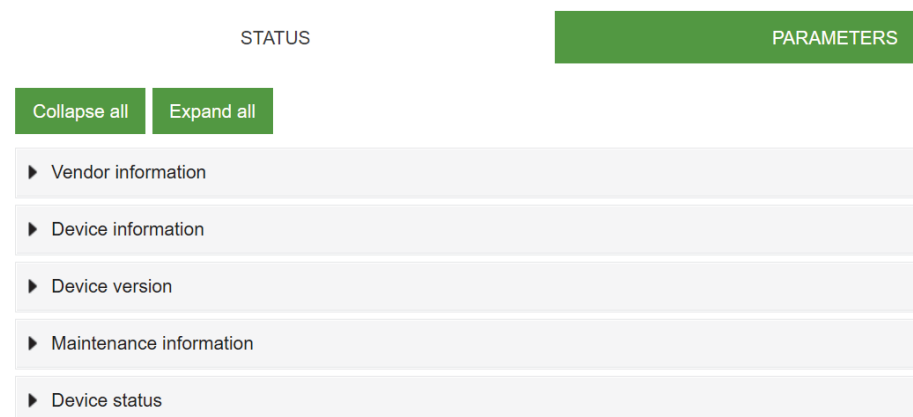

Fig. 10-4: “Status” menu item

Manufacturer information

“Manufacturer Information” displays the following information:

Parameter designation	Meaning
Manufacturer name	Fixed manufacturer data
Manufacturer address	Fixed manufacturer data
Manufacturer phone	Fixed manufacturer data
Manufacturer URL	Manufacturer website

Device information

“Device information” displays the following information:

Parameter designation	Meaning
Order number	Article number of the device
MAC address	Fixed MAC address of the device
Hardware name	Fixed article designation of the device
Software name	Fieldbus designation of the device
Software number	Serial number of the device

Device version

“Device version” displays the following information:

Parameter designation	Meaning
Hardware version	Design version of the hardware
Software version	Currently running software version in the device
Website version	Currently running version of the web server in the device

Maintenance information



The maintenance information can only be read here. Any entry or changes to the fields is done via "Settings/Maintenance → Maintenance information".

"Maintenance information" displays the following information:

Parameter designation	Meaning
Name	Name of the device, free text
Mounting location	Location name, free text
Contact information	Contact, free text
Description	Description, free text
Last maintenance date (yyyy-mm-dd)	Free date entry
Next maintenance date (yyyy-mm-dd)	Free date entry

Device status

"Device status" displays the following information:

Parameter designation	Meaning
Sensor supply voltage (US)	Display of the sensor voltage in Volt
Sensor supply current (IS)	Display of the sensor voltage in Ampere
Temperature [°C]	Display of internal device temperature in degrees Celsius
Operating hours [dddd:hh:mm:ss]	Total operating hours since the device has been switched on for the first time
Number of restarts	Number of device restarts

10.2.2 PARAMETERS menu

The “Parameters” menu item contains the following subitems:

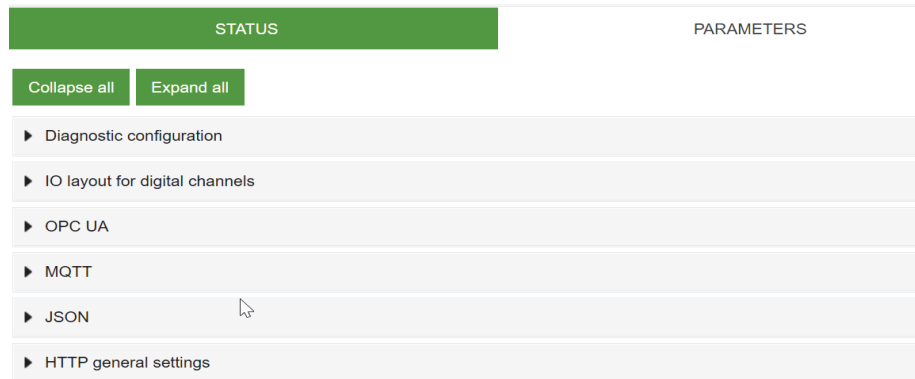

Fig. 10-5: “Parameters” menu

OPC UA

Users with admin and operator rights can change settings and enter the OPC UA port number. Guest users have reading rights.

“OPC UA” displays the following information:

Parameter designation	Meaning
Enable OPC UA server	OPC UA server on the assembly active / passive
Allow OPC UA clients to write ISDU data	OPC UA client is allowed to write ISDU (Indexed Service Data Unit) data to the assembly on the IO-Link master
Allow OPC UA clients to write PDO data	OPC UA client is allowed to write PDO (Process Data Objects) to the assembly on the IO-Link master
OPC UA port number	Display / definition of the OPC UA port

MQTT

Users with admin and operator rights can change settings and enter the IP address of the MQTT server. Guest users have reading rights.

“MQTT” displays the following information:

Parameter designation	Meaning
Enable MQTT	MQTT client on the assembly active / passive
MQTT server IP address	IP address of the MQTT server
MQTT Client ID	Read/write the MQTT client ID
Client head topic	Read/write an MQTT topic
Topic for system data	Read/write an MQTT topic

JSON

Users with admin and operator rights can activate and deactivate JSON. Guest users have reading rights.

“JSON” displays the following information:

Parameter designation	Meaning
Enable JSON	JSON interface on the assembly active / passive

HTTP settings

Users with admin and operator rights can disable web server access. Guest users have read rights.

Parameter-Bezeichnung	Bedeutung
Web server access	Web server on the module active/passive

**NOTE**

The change is only effective after a restart of the module.

10.2.3 DIAGNOSTICS menu

The “Diagnostics” menu item shows the incoming and outgoing alarms of the master.

The menu shows an overview of diagnostic messages.

Depending on the setting in the “Please select an entry” drop-down menu, the following diagnostics of the module are displayed:

- Active
 - ✓ All diagnostics pending at the time of the web server call.
 - ✓ All diagnostics that are no longer available are not displayed.
- History
 - ✓ All diagnostics from the remanent diagnostic memory that are no longer available are displayed.
 - ✓ The module can hold up to 40 diagnostic entries in memory. The latest diagnostics overwrites the oldest one in the memory.

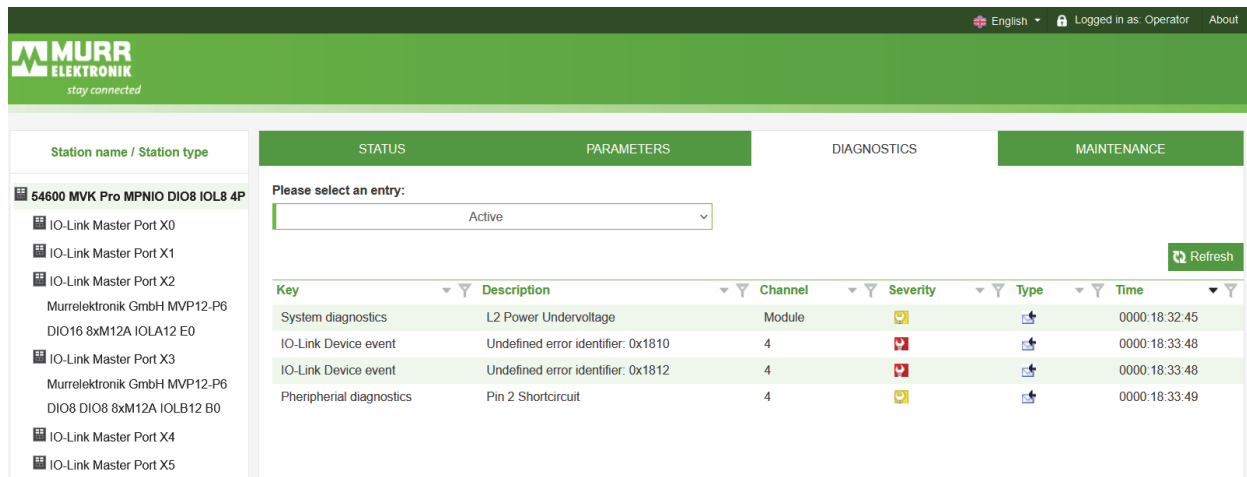

Fig. 10-6: Menu item “Diagnostics”

10.2.4 MAINTENANCE menu

In the “Maintenance” menu item, users with admin and operator rights can delete the diagnostic memory.



Fig. 10-7: Deleting the diagnostic memory

10.3 IO-Link Master Port

The system tree displays 8 IO-Link master ports (X0 ... X7) that can be selected individually. Depending on the user role, information can be read or functions can be configured here. When IO-Link communication is active, the IO-Link device name automatically appears under the relevant port.

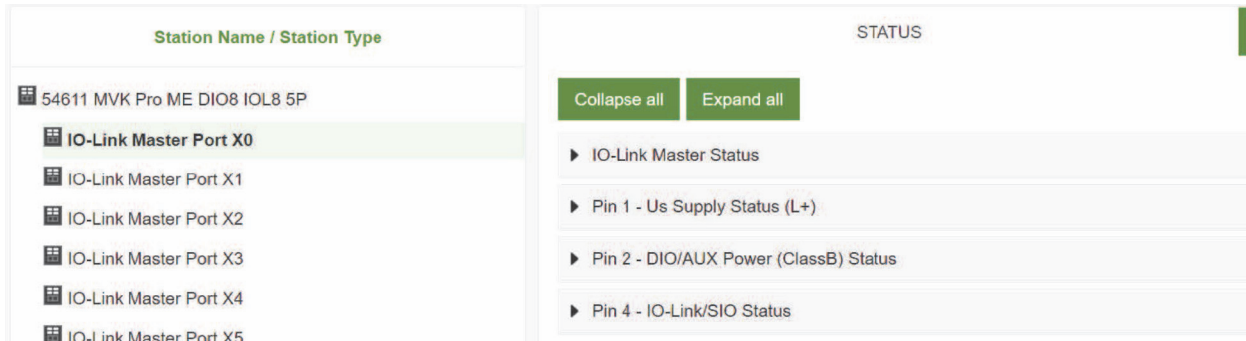

Fig. 10-8: IO-Link master port

10.3.1 STATUS menu

The IO-Link master status is displayed here in the Status menu.



Fig. 10-9: IO-Link master port – IO-Link master status

If pin 4 is in IO-Link operation, all relevant IO-Link data including the I/O bytes of the device are displayed (see Fig. 10-9: "IO-Link master port – IO-Link master status").

If pin 4 is in operation without a connected IO-Link device, a message appears indicating that no device is connected.

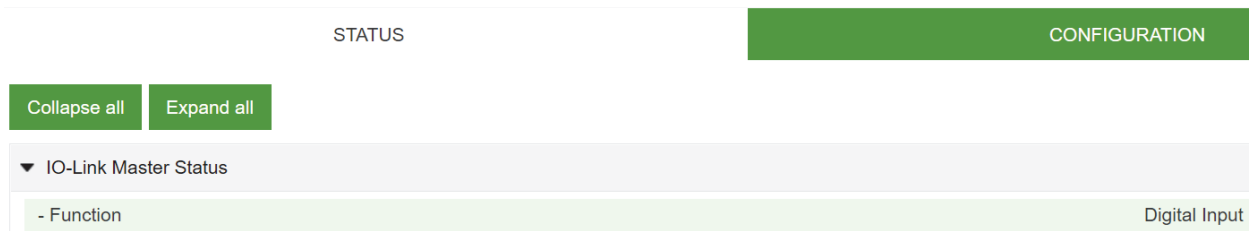

Fig. 10-10: IO-Link master port – IO-Link master status in digital operation

If pin 4 is configured as a digital input, for example, this is also indicated here (see Fig. 10-10: "IO-Link master port – IO-Link master status in digital operation").

Possible displays are:

- Status: Disabled
- Status: Digital input
- Status: Digital output

Port status - pin 1

“Port status - pin 1” displays the following information:

Parameter designation	Meaning
Temperature [°C]	Temperature in degrees Celsius
Voltage [V]	Voltage in Volt
Current [A]	Current in Ampere
Status	State of the pin

Port status - pin 2

“Port status - pin 2” displays the following information:

Parameter designation	Meaning
Temperature [°C]	Temperature in degrees Celsius
Voltage [V]	Voltage in Volt
Current [A]	Current in Ampere
Status	State of the pin

Port status - pin 4

“Port status - pin 4” displays the following information:

Parameter designation	Meaning
Temperature [°C]	Temperature in degrees Celsius
Voltage [V]	Voltage in Volt
Current [A]	Current in Ampere
Status	State of the pin

10.3.2 INFORMATION menu

The “Information” menu item contains the following subitems:

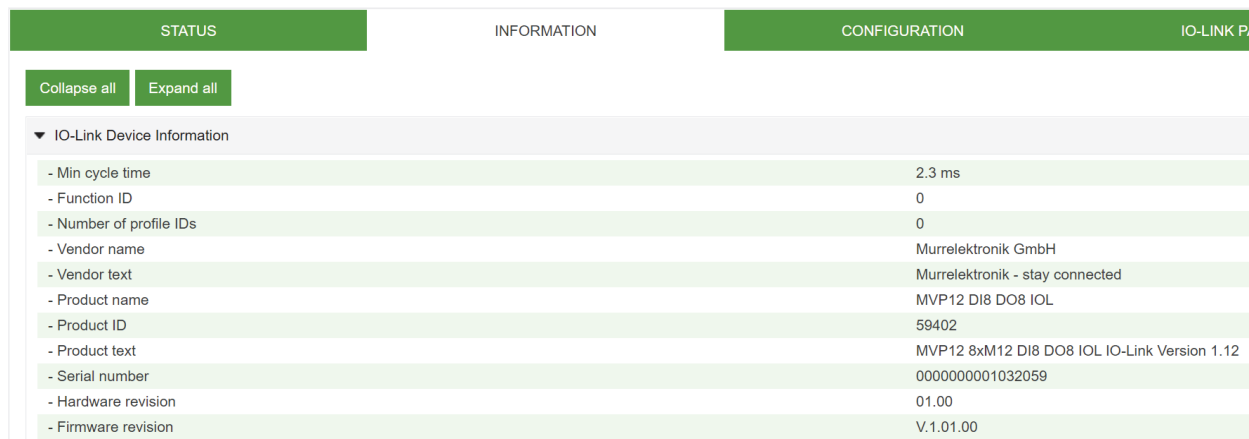

Fig. 10-11: IO-Link master port – “Information”

IO-Link device information

The technical data and manufacturer information of a connected and active IO-Link device at the corresponding master port are displayed here.

“IO-Link device information” displays the following information:

Parameter designation	Meaning
Min. cycle time	Minimum process cycle time of the IO-Link device
Function ID	Function ID of the IO-Link device
Number of profile IDs	Number of profiles supported by the IO-Link device
Manufacturer name	Name of the IO-Link device manufacturer
Manufacturer text	Manufacturer text of the IO-Link device
Product name	Product name of the IO-Link device
Product ID	Article number of the IO-Link device
Product text	Additional description of the IO-Link device
Serial number	Serial number
Hardware version	Hardware version
Firmware version	Firmware version

10.3.3 CONFIGURATION menu

In the “Configuration” menu item of the selected IO-Link port, the setting for pin 1, pin 2 and pin 4 is indicated at the selected port and can be configured there.

Users with operator and admin rights can set the functions and behavior of pin 1, pin 2 and pin 4.

Users with service and maintenance rights have reading rights.

Pin 4 can be deactivated or configured as IO-Link master, input, or output.

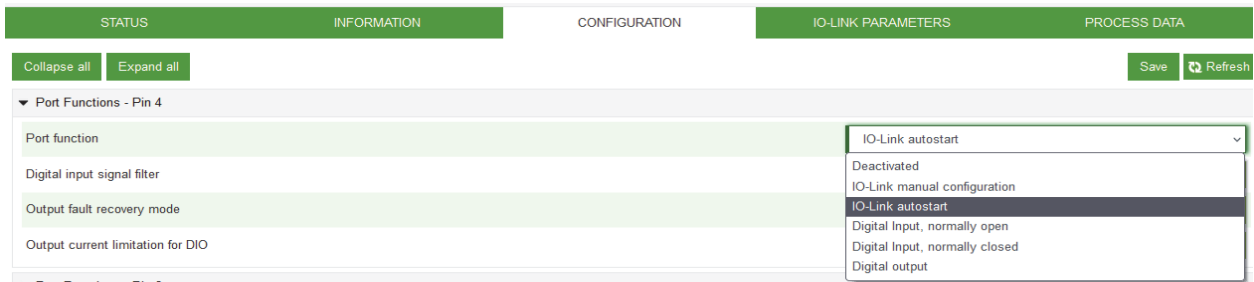

Fig. 10-12: IO-Link master port – configuration (pin 4)

Pin 2 can be deactivated or configured as input, output, or DIO in “Automatic Mode”.

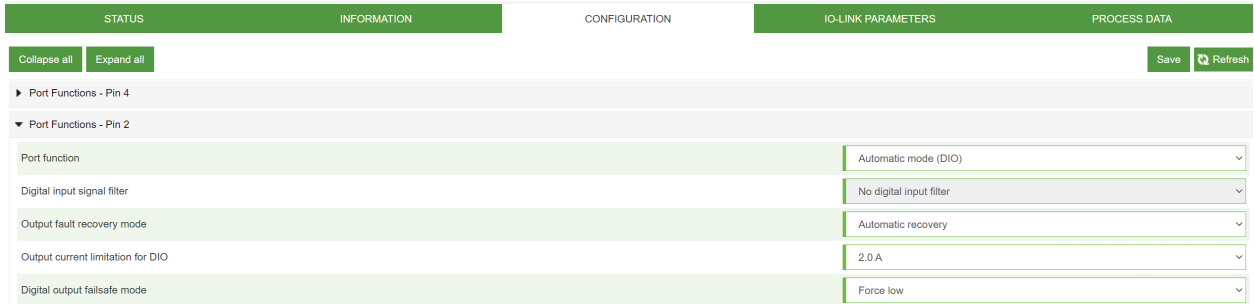

Fig. 10-13: IO-Link master port – configuration – IQ behavior (pin 2)

If pin 2 or pin 4 are configured as input, the digital input filters can be set individually.

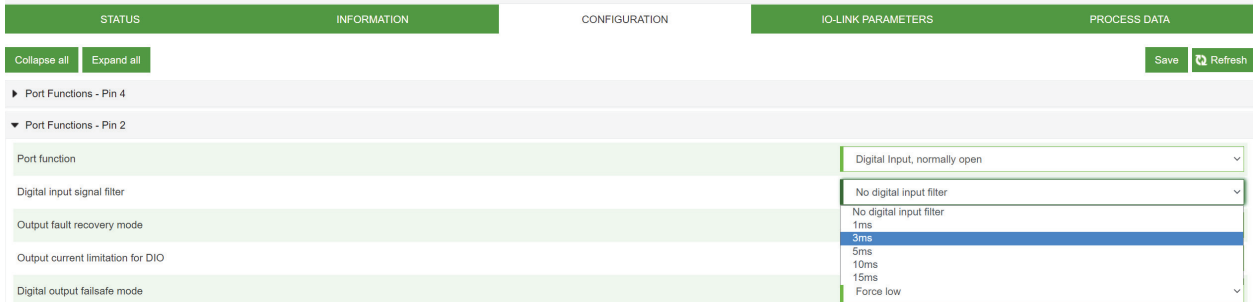

Fig. 10-14: IO-Link master port – configuration – setting digital input filters

10.3.4 IO-LINK PARAMETER menu

In this menu item, the ISDU (Index Service Data Unit) of the device can be read and written during IO-Link operation. This enables an IO-Link device to be evaluated or configured without a controller. The input can be in hex or ASCII format.



Observe the information in the IO-Link device manufacturer's manual.

Users with maintenance and admin rights can write ISDU values. Users with service rights have reading rights.

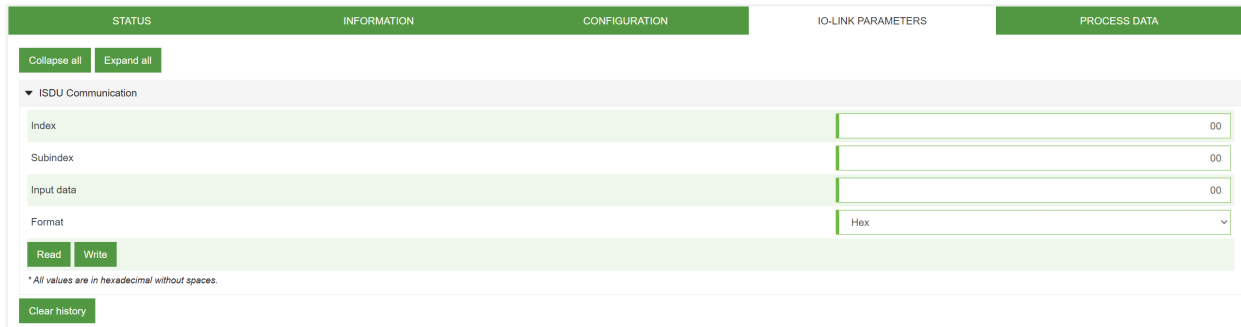

Fig. 10-15: IO-Link master port – IO-LINK PARAMETER

10.3.5 PROCESS DATA menu

In the “Process data” menu item, the current process data of the connected IO-Link device is continuously displayed if pin 4 of the corresponding port has been configured as an IOL port. Example: port X2: pin 4 (IO-Link autostart) and pin 2 (digital output statically on).

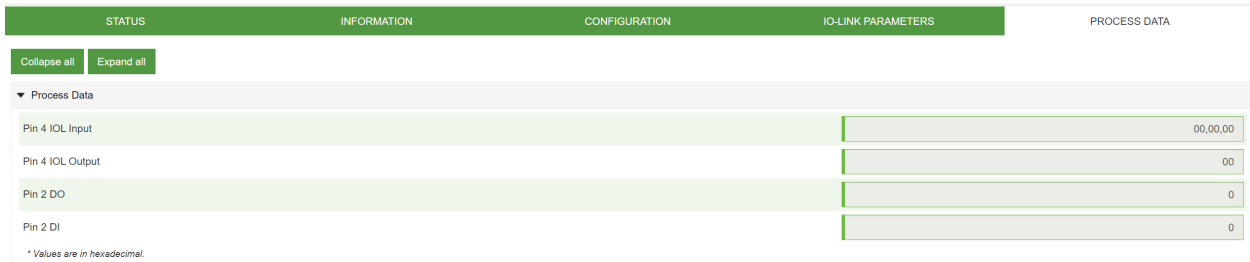

Fig. 10-16: IO-Link master port - PROCESS DATA

In this menu item the current states of the digital inputs are displayed. Example: port X1: pin 4 (DI) and pin 2 (DI)

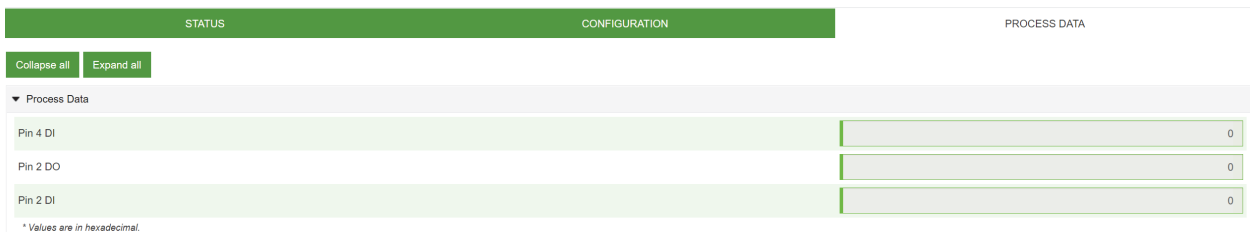

Fig. 10-17: IO-Link master port – digital inputs – PROCESS DATA

10.4 Settings / Maintenance

10.4.1 DEVICE CONFIGURATION menu

Logged in user can change the IP setting of this device through the web server, unless a DHCP server is available.



Factory default IP address setting for the module is DHCP.

In the “Settings / Maintenance” – “Device configuration” menu the static IP address with subnet mask and gateway can be entered.

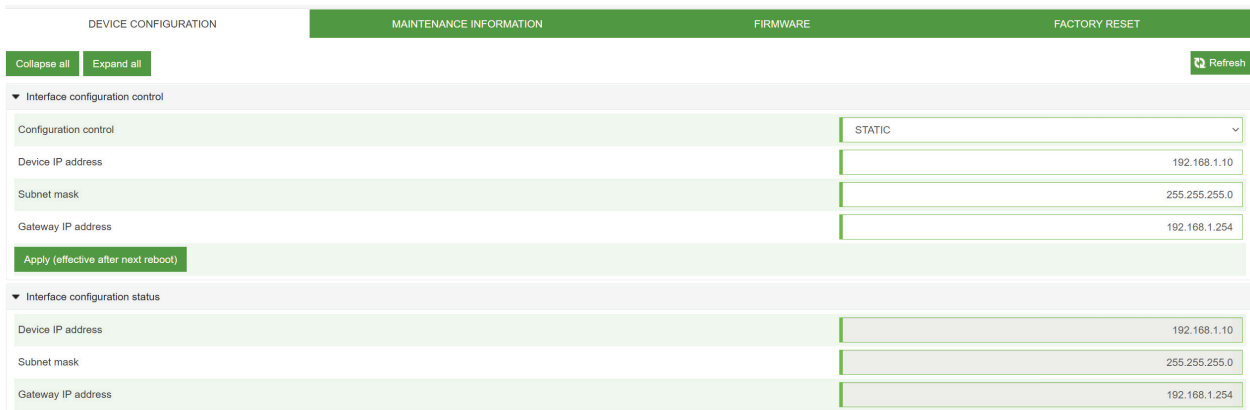

The screenshot shows the 'DEVICE CONFIGURATION' menu with the following sections:

- Configuration control:** A dropdown menu set to 'STATIC'.
- Device IP address:** Input field with value '192.168.1.10'.
- Subnet mask:** Input field with value '255.255.255.0'.
- Gateway IP address:** Input field with value '192.168.1.254'.
- Apply (effective after next reboot):** A green button.
- Interface configuration status:** A section showing the current status of the IP settings, with the same values as above.

Fig. 10-18: IP address EtherNet/IP settings

After confirmation with “Application”, which becomes active after the next reboot, the rotary switches must be set to “000” and the module must be switched off and on. After that, the fixed IP address is permanently assigned to the module.

If the module has a fixed address, the IP configuration of STATIC can be reset to BOOTP or DHCP in this menu.

10.4.2 MAINTENANCE INFORMATION menu

Users with service, maintenance and admin rights can enter the device information here.

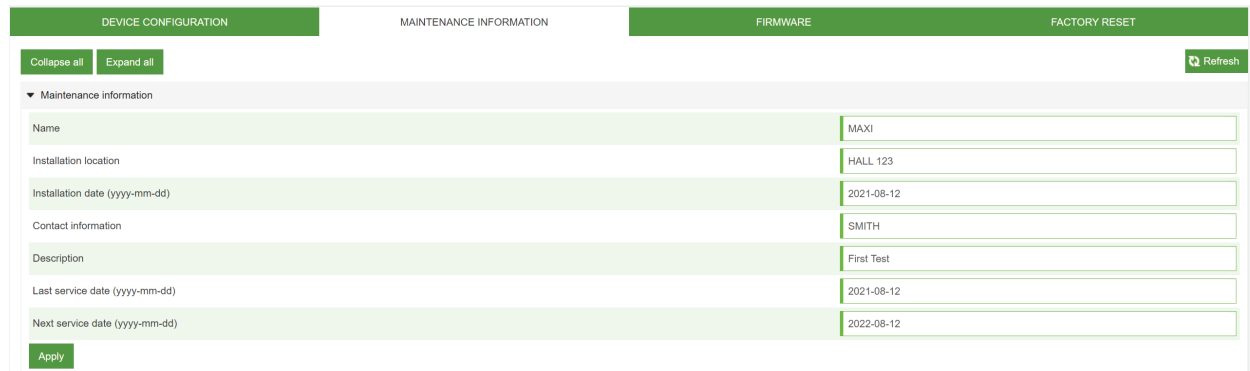

The screenshot shows the 'MAINTENANCE INFORMATION' menu with the following sections:

- Name:** Input field with value 'MAXI'.
- Installation location:** Input field with value 'HALL 123'.
- Installation date (yyyy-mm-dd):** Input field with value '2021-08-12'.
- Contact information:** Input field with value 'SMITH'.
- Description:** Input field with value 'First Test'.
- Last service date (yyyy-mm-dd):** Input field with value '2021-08-12'.
- Next service date (yyyy-mm-dd):** Input field with value '2022-08-12'.
- Apply:** A green button.

Fig. 10-19: Setting maintenance information

The maintenance information appears in the device under the menu item “Status” and submenu “Maintenance information”.

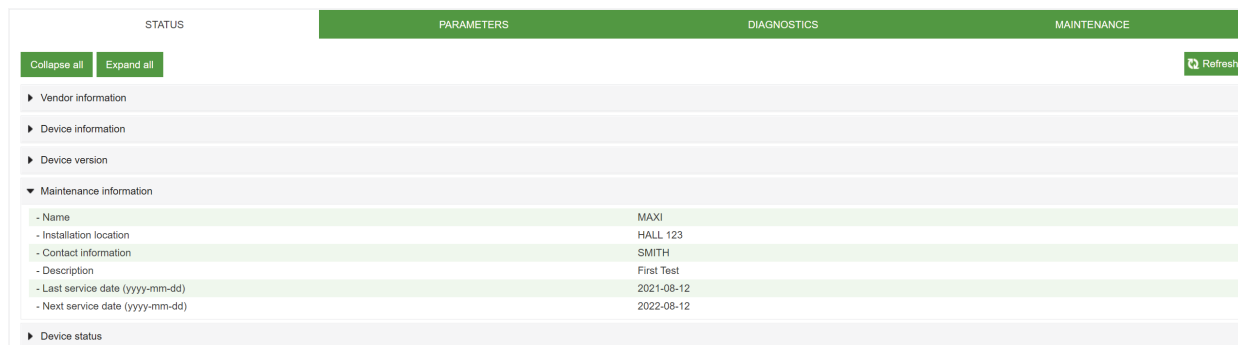

Fig. 10-20: Maintenance information status

10.4.3 FIRMWARE menu

This menu item displays the data of the firmware running on the device. Users with service, maintenance and admin rights can upload new firmware, provided in ZIP folders, to the device. After a successful upload, the device checks the firmware container and automatically starts with the new firmware version.

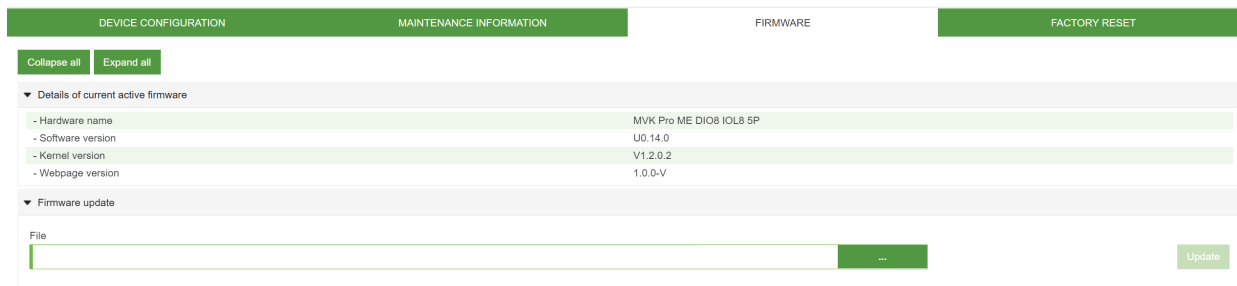

Fig. 10-21: Firmware

10.4.4 FACTORY RESET menu

In this menu item, users with service, maintenance and admin rights can reset the entire module or individual areas (device information, network, application).

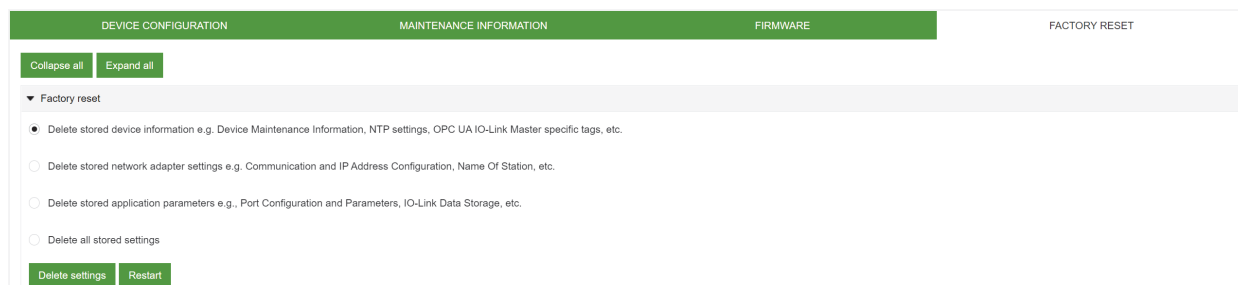

Fig. 10-22: Factory reset

10.5 User Administration

User management can only be performed with admin rights.

Upon receipt of the product, the administrator account is “admin” and the password is “private”.



The default administrator password can be changed from the controller in the plant with the fieldbus running.

Users log in and out at the bottom left of the system tree.

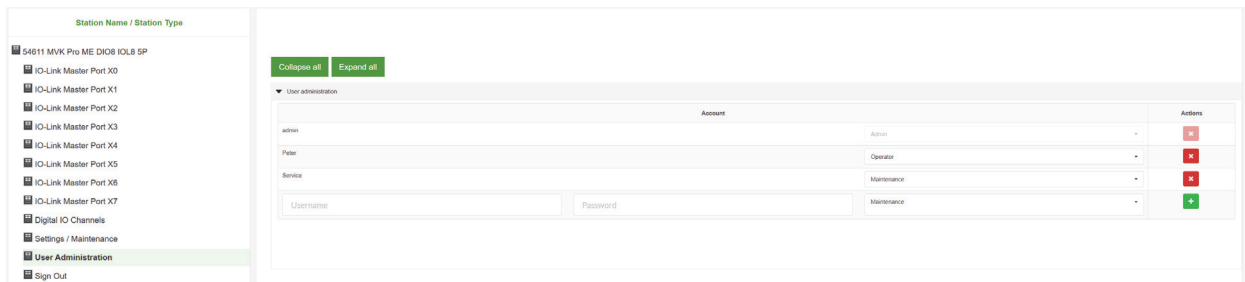

Fig. 10-23: User management

10.6 Digital IO Channels / IO Overview

In the “Configuration” menu of the selected IO-Link port, the setting for pin 2 and pin 4 is indicated at the selected port. Outputs can be set under certain conditions.

10.6.1 Input data

Every user can observe the digital states of the inputs configured on the device.

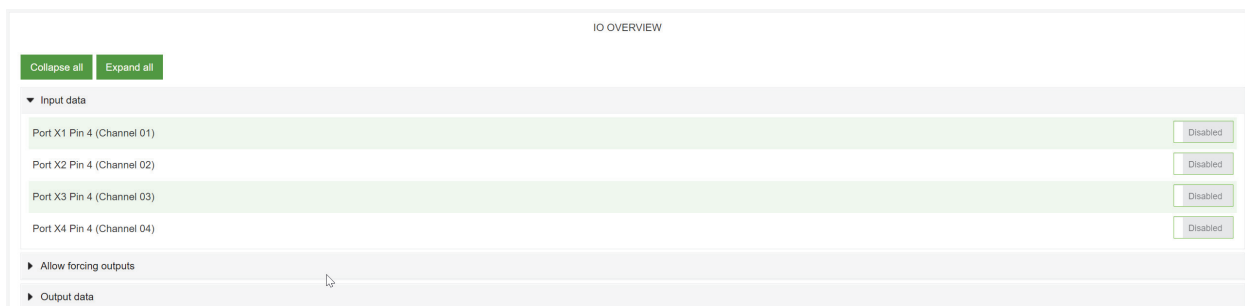

Fig. 10-24: Input data overview

10.6.2 Output data

Allow forcing outputs

Users with admin, service and maintenance rights can allow/enable forcing of outputs in this menu.

The right to do this is only granted if the module is not in an active fieldbus connection with the controller. The controller always has priority.

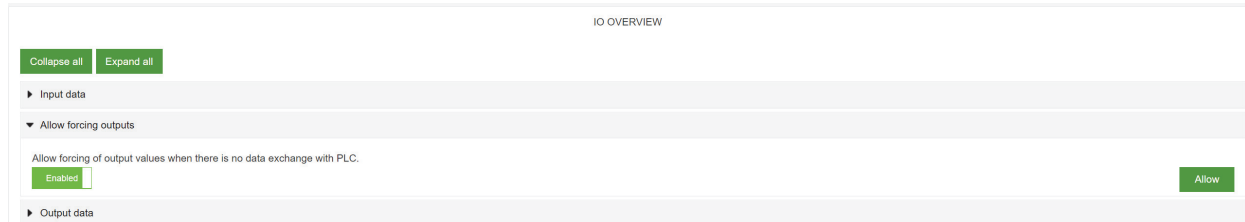

Fig. 10-25: Allow forcing outputs

Setting of output data

Guest users are not allowed to force outputs.

All other users (admin, operator, maintenance) are allowed to force outputs.

As soon as the user (admin, operator, maintenance) logs out, the outputs default to "0".

As soon as a fieldbus is actively working with the module, the outputs go to "0" and then adopt the status they receive from the controller.

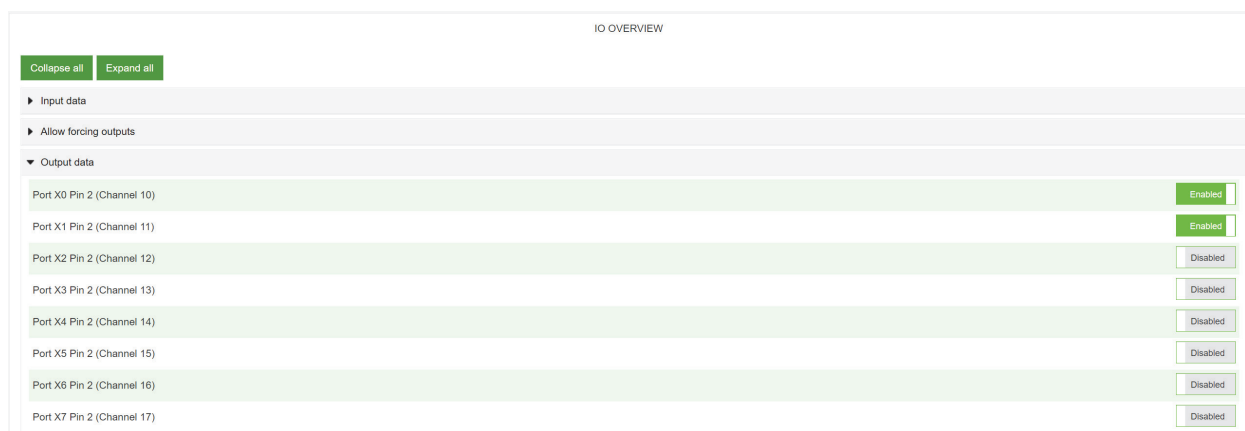

Fig. 10-26: Force output data

11 Maintenance and cleaning

NOTICE

Damage caused by defective or damaged devices!

The functioning of the modules is not guaranteed.

- ➔ Replace defective or damaged devices.



NOTE

Device cleaning.

- ➔ Use only oil-free compressed air or spirit.
- ➔ Only use lint-free materials (e.g. leather cloth).
- ➔ Do not use contact spray.

12 Appendix

12.1 Supported EtherNet/IP objects

This chapter is an enumeration of the CIP objects and services supported by and implemented in this product. For more detailed descriptions of the individual objects and attributes, please refer to the EtherNet/IP specification.

12.1.1 Standard object class

12.1.1.1 Identity Object (Class Code: 0x01)

Class Attribute

Attribute ID	Access Rule	Name	Data Type	Attribute description	Semantics of Values
1	Get	Revision	UINT	Revision of this object	The current value assigned to this attribute is two (02). In case of updates that require an increase in this value, the value of this attribute increases by 1.
2	Get	Max Instance	UINT	Maximum instance number of an object currently created in this class level of the device.	The largest instance number of a created object at this class hierarchy level. The value currently assigned to this attribute is one (01).
6	Get	Max ID Class Attribute	UINT	The attribute ID number of the last class attribute of the class definition implemented in the device.	The value of this attribute will be seven (07).
7	Get	Max ID Instance Attributes	UINT	The attribute ID number of the last instance attribute of the class definition implemented in the device.	The value of this attribute will differ by product variant. This attribute will show nine (09).

Tab. 12-1: Identity Object Class Attribute

Instance Attribute

Attribute ID	Access Rule	Name	Data Type	Description of Attribute	Value
1	Get	Vendor ID	UINT	Identification of each vendor by number	640
2	Get	Device Type	UINT	Indication of general type of product	12
3	Get	Product Code	UINT	Identification of a particular product of an individual vendor	Example: 54611
4	Get	Revision	STRUCT of:	Revision of the item the Identity Object represents	
		Major Revision	USINT		1
		Minor Revision	USINT		1
5	Get	State	WORD	Summary status of device	
6	Get	Serial Number	UDINT	Serial number of device	
7	Get	Product Name	SHORT_STRING	Human readable identification	Example: IMPACT67 E DIO16 4P

Attribute ID	Access Rule	Name	Data Type	Description of Attribute	Value
8	Get	State	USINT	Present state of the device as represented by the state transition diagram	

Tab. 12-2: Identity Object Instance Attribute

Common Services

Service Code	Implemented for		Service Name	Description of Service
	Class	Instance		
0x01	No	Yes	Get_Attribute_All	Returns a predefined listing of this objects attributes.
0x05	No	Yes	Reset	Invokes the Reset service for the device. Option 0 restarts the device. Option 1 invokes a factory reset of the device.
0x0E	Yes	Yes	Get_Attribute_Single	Returns the contents of the specified attribute.

Tab. 12-3: Common Services of Identity Object

12.1.1.2 Message Router Object (Class Code: 0x02)

This Object has no accessible attributes.

12.1.1.3 Assembly Object (Class Code: 0x04)

Class Attribute

Attribute ID	Access Rule	Name	Data Type	Attribute description	Semantics of Values
1	Get	Revision	UINT	Revision of this object	The current value assigned to this attribute is one (01). If updates that require an increase in this value are made, then the value of this attribute increases by 1.

Tab. 12-4: Assembly Object Class Attribute

Instance attributes

Attribute ID	Access Rule	Name	Data Type	Attribute description
3	Set,Get	Data	ARRAY of BYTE	
4	Get	Size	UINT	Number of bytes in Attribute 3

Tab. 12-5: Assembly Object Instance Attribute

Common Services

Service Code	Implemented for		Service Name	Description of Service
	Class	Instance		
0x0E	Yes	Yes	Get_Attribute_Single	Returns the contents of the specified attribute.
0x10	No	Yes	Set_Attribute_Single	Modifies an attribute value.

Tab. 12-6: Common Services of Assembly Object

12.1.1.4 Connection Manager Object (Class Code: 0x06)

Ethernet Link Object Class Attribute

Attribute ID	Access Rule	Name	Data Type	Description of Attribute	Semantics of Values
1	Get	Revision	UINT	Revision of this object	The current value assigned to this attribute is one (01). If updates that require an increase in this value are made, then the value of this attribute increases by 1.
2	Get	Max Instance	UINT	Maximum instance number of an object currently created in this class level of the device.	The largest instance number of a created object at this class hierarchy level. This attribute will show one (01).

Tab. 12-7: Ethernet Link Object Class Attributes

Instance Attribute: There are no Instance Attributes implemented for this object.

Common services: Common Services of Ethernet Link Object.

Service Code	Implemented for		Service Name	Description of Service
	Class	Instance		
0x0E	Yes	No	Get_Attribute_Single	Returns the contents of the specified attribute.

Tab. 12-8: Common Services of Ethernet Link Object

12.1.1.5 Device Level Ring (DLR) Object (Class Code: 0x47)

Class Attribute

Attribute ID	Access Rule	Name	Data Type	Description of Attribute	Semantics of Values
1	Get	Revision	UINT	Revision of this object	The current value assigned to this attribute is three (03). If updates that require an increase in this value are made, then the value of this attribute increases by 1.

Tab. 12-9: Device Level Ring Object Class Attribute

Instance attributes

Attribute ID	Access Rule	Name	Data Type	Attribute description
1	Get	Network Topology	USINT	Current network topology mode
2	Get	Network State	USINT	Current status of network
10	Get	Active Supervisor Address	STRUCT of:	IP and/or MAC address of the active ring supervisor
			UDINT	Supervisor IP Address
			ARRAY of 6 USINTs	Supervisor MAC Address
12	Get	Capability Flags	USINT	Describes the DLR capabilities of the device

Tab. 12-10: Device Level Ring Object Instance Attribute

Common Services

Service Code	Implemented for		Service Name	Description of Service
	Class	Instance		
0x01	No	Yes	Get_Attribute_All	Returns a predefined listing of this objects attributes.
0x0E	Yes	Yes	Set_Attribute_Single	Returns the contents of the specified attribute.

Tab. 12-11: Common Services of Device Level Ring Object

12.1.1.6 Quality of Service Object (Class Code: 0x48)

Class Attribute

Attribute ID	Access Rule	Name	Data Type	Description of Attribute	Semantics of Values
1	Get	Revision	UINT	Revision of this object	The current value assigned to this attribute is one (01). If updates that require an increase in this value are made, then the value of this attribute increases by 1.
2	Get	Max Instance	UINT	Maximum instance number of an object currently created in this class level of the device.	The largest instance number of a created object at this class hierarchy level. This attribute will show one (01).

Tab. 12-12: Quality of Service Object Class Attribute

Instance Attribute

Attribute ID	Access Rule	Name	Data Type	Description of Attribute
1	Set, Get	802.1Q Tag Enable	USINT	Enables or disables sending 802.1Q frames on CIP and IEEE 1588 messages.
4	Set, Get	DSCP Urgent	USINT	DSCP value for CIP transport class 0/1 Urgent priority messages.
5	Set, Get	DSCP Scheduled	USINT	DSCP value for CIP transport class 0/1 Scheduled priority messages.
6	Set, Get	DSCP High	USINT	DSCP value for CIP transport class 0/1 High priority messages.
7	Set, Get	DSCP Low	USINT	DSCP value for CIP transport class 0/1 low priority messages.
8	Set, Get	DSCP Explicit	USINT	DSCP value for CIP explicit messages (transport class 2/3 and UCMM) and all other EtherNet/IP encapsulation messages.

Tab. 12-13: Quality of Service Object Instance Attribute

Common Services

Service Code	Implemented for		Service Name	Description of Service
	Class	Instance		
0x0E	Yes	Yes	Get_Attribute_Single	Returns the contents of the specified attribute.
0x10	No	Yes	Set_Attribute_Single	Modifies the contents of the attributes of the class or object.

Tab. 12-14: Common Services of Quality of Service

12.1.1.7 TCP/IP Interface Object (Class Code: 0xF5)

Class Attribute

Attribute ID	Access Rule	Name	Data Type	Description of Attribute	Semantics of Values
1	Get	Revision	UINT	Revision of this object	The current value assigned to this attribute is four (04). If updates that require an increase in this value are made, then the value of this attribute increases by 1.
2	Get	Max Instance	UINT	Maximum instance number of an object currently created in this class level of the device,	The largest instance number of a created object at this class hierarchy level. This attribute will show one (01).

Tab. 12-15: TCP/IP Interface Object Class Attribute

Instance Attribute

Attribute ID	Access Rule	Name	Data Type	Description of Attribute
1	Get	Status	USINT	Interface status
2	Get	Configuration Capability	USINT	Interface capability flags.
3	Set, Get	Configuration Capability	USINT	Interface control flags.
4	Get	Physical Link Object	STRUCT of	Path to physical link object.
		Path size	UINT	Size of Path
		Path	Padded EPATH	Logical segments identifying the physical link object.
5	Set, Get	Interface Configuration	STRUCT of	TCP/IP network interface configuration.
		IP Address	UDINT	The device's IP address.
		Network Mask	UDINT	The device's network mask.
		Gateway Address	UDINT	Default gateway address.
		Name Server	UDINT	Primary name server
		Name Server 2	UDINT	Secondary name server.
		Domain Name	STRING	Default domain name.
6	Set, Get	Host Name	STRING	Host name
10	Set, Get	SelectAcd	BOOL	Activates the use of ACD.
11	Set, Get	LastConflictDetected	STRUCT of	Structure containing information related to the last conflict detected.
		AcdActivity	USINT	State of ACD activity when last conflict detected.
		RemoteMAC	Array of 6 USINT	MAC address of remote node from the ARP PDU in which a conflict was detected.
		ArpPdu	ARRAY of 28 USINT	Copy of the raw ARP PDU in which a conflict was detected.
12	n.c.			
13	Get	Encapsulation Inactivity Timeout	UINT	Number of seconds of inactivity before TCP connection or DTLS session is closed.

Tab. 12-16: TCP/IP Interface Object Instance Attribute

Common Services

Service Code	Implemented for		Service Name	Description of Service
	Class	Instance		
0x01	No	Yes	Get_Attribute_All	Returns a predefined listing of this objects attributes.
0x0E	Yes	Yes	Get_Attribute_Single	Returns the contents of the specified attribute.
0x10	NO	Yes	Set_Attribute_Single	Modifies a single attribute.

Tab. 12-17: Common Services of TCP/IP Interface Object

12.1.1.8 EtherNet/IP Link Object (Class Code: 0xF6)

Class Attribute

Attribute ID	Access Rule	Name	Data Type	Description of Attribute	Semantics of Values
1	Get	Revision	UINT	Revision of this object.	The current value assigned to this attribute is four (04). If updates that require an increase in this value are made, then the value of this attribute increases by 1.
2	Get	Max Instance	UINT	Maximum instance number of an object currently created in this class level of the device.	The largest instance number of a created object at this class hierarchy level. This attribute will show two (02).
3	Get	Number of Instances	UINT	Number of object instances currently created at this class level of the device.	The number of object instances at this class hierarchy level. This attribute will show two (02).

Tab. 12-18: Ethernet Link Object Class Attribute

Instance Attribute

Attribute ID	Access Rule	Name	Data Type	Description of Attribute
1	Get	Interface Speed	USINT	Interface speed currently in use.
2	Get	Interface Flags	USINT	Interface status flags.
3	Get	Physical Address	USINT	MAC layer address.
4	Get	Interface Counters	STRUCT of	
		In Octets	UDINT	Octets received on the interface.
		In Ucast Packets	UDINT	Unicast packets received on the interface.
		In NUcast Packets	UDINT	Non-unicast packets received on the interface.
		In Discards	UDINT	Inbound packets received on the interface but discarded.
		In Errors	UDINT	Inbound packets that contain errors (does not include In Discards).
		In Unknown Protos	UDINT	Inbound packets with unknown protocol.
		Out Octets	UDINT	Octets sent on the interface.
		Out Ucast Packets	UDINT	Unicast packets sent on the interface.
		Out NUcast Packets	UDINT	Non-unicast packets sent on the interface.
		Out Discards	UDINT	Outbound packets discarded.
Out Errors	UDINT	Outbound packets that contain errors.		

Attribute ID	Access Rule	Name	Data Type	Description of Attribute
5	Get	Media Counters	STRUCT of	Media-specific counters
		Alignment Errors	UDINT	Frames received that are not an integral number of octets in length.
		FCS Errors	UDINT	Frames received that do not pass the FCS check.
		Single Collisions	UDINT	Successfully transmitted frames which experienced exactly one collision.
		Multiple Kollisionen	UDINT	Successfully transmitted frames which experienced more than one collision.
		SQE Test Errors	UDINT	Number of times SQE test error message is generated.
		Deferred Transmissions	UDINT	Frames for which first transmission attempt is delayed because the medium is busy.
		Late Collisions	UDINT	Number of times a collision is detected later than 512 bit-times into the transmission of a packet.
		Excessive Collisions	UDINT	Frames for which transmission fails due to excessive collisions.
		MAC Transmit Errors	UDINT	Frames for which transmission fails due to an internal MAC sublayer transmit error.
		Carrier Sense Errors	UDINT	Times that the carrier sense condition was lost or never asserted when attempting to transmit a frame.
		Frame Too Long	UDINT	Frames received that exceed the maximum permitted frame size.
		MAC Receive Errors	UDINT	Frames for which reception on an interface fails due to an internal MAC sublayer receive error.
6	Set, Get	Interface Control	STRUCT of	Configuration for physical interface.
		Control Bits	WORD	Interface Control Bits
		Forced Interface Speed	UINT	Speed at which the interface shall be forced to operate.
7	Get	Interface Type	USINT	Type of interface: twisted pair, fiber, internal, etc.
8	Get	Interface State	USINT	Current state of the interface: operational, disabled, etc.
9	Set, Get	Admin State	USINT	Administrative state: enable, disable.
10	Set, Get	Interface Label	SHORT_STRING	Human readable identification.
11	Get	Interface Capability	STRUCT of	Indication of capabilities of the interface.
		Capability Bits	DWORD	Interface capabilities, other than speed/duplex.
		Speed/Duplex Options	STRUCT of	Indicates speed/duplex pairs supported in the Interface Control attribute.
			USINT	Speed/Duplex Array Count.
			ARRAY of STRUCT of	Speed/Duplex Array
			UINT	Interface Speed
	UINT	Interface Duplex Mode		

Tab. 12-19: Ethernet Link Object Instance Attribute

Common Services

Service Code	Implemented for		Service Name	Description of Service
	Class	Instance		
0x01	No	Yes	Get_Attribute_All	Returns a predefined listing of this objects attributes.
0x0E	Yes	Yes	Get_Attribute_Single	Returns the contents of the specified attribute.
0x4C	No	Yes ¹	Set_Attribute_Single	Gets then clears the specified attribute.

¹ The Get_and_Clear service is only implemented for the attributes 4 and 5.

Tab. 12-20: Common Services of Ethernet Link Object

12.1.2 Vendor Specific Objects

12.1.2.1 IO-Link Device Parameter Object (Class Code 0x83)

Class Attribute

Attribute ID	Access Rule	Name	Data Type	Attribute description	Semantics of Values
1	Get	Revision	UINT	Revision of this object	The current value assigned to this attribute is one (01). If updates that require an increase in this value are made, then the value of this attribute increases by 1.
2	Get	Max Instance	UINT	Maximum instance number of an object currently created in this class level of the device.	The largest instance number of a created object at this class hierarchy level. This attribute will show one (01).
6	Get	Max ID Class Attribute	UINT	The attribute ID number of the last class attribute of the class definition implemented in the device.	The value of this attribute will be seven (07).
7	Get	Max ID Instance Attributes	UINT	The attribute ID number of the last instance attribute of the class definition implemented in the device.	The value of this attribute will differ by product variant. Part number 55143 will show 2 and 55144 will show 4.

Tab. 12-21: IO-Link Device Parameter Object Class Attribute

Instance attributes

Instance attributes are not supported.

Object-Specific Services

The following class-specific services are defined for the IO-Link Device Parameter Object.

Service Code	Implemented for		Service Name	Description of Service
	Class	Instance		
0x4B	No	Yes	Read_ISDU	Read the parameter in the IO-Link Device in raw format. i.e. Big Endian
0x4C	No	Yes	Write_ISDU	Write the parameter in the IO-Link Device in raw format i.e. Big Endian

Tab. 12-22: Common services of Object-Specific Services

Read_ISDU Service

Name	Data Type	Description
Index	UINT	IO-Link device index
Subindex	USINT	IO-Link device subindex

Tab. 12-23: Read_ISDU Service structure

Write_ISDU Service

Name	Data Type	Description
Index	UINT	IO-Link device index
Subindex	USINT	IO-Link device subindex
Data	ARRAY of USINT	IO-Link device ISDU data

Tab. 12-24: Write_ISDU Service structure

12.2 Explanation of the process data

12.2.1 Digital Input

The order of the digital input data depends on the configuration parameter "Pin_Port_based_IO_Layout". This is explained in the following tables:

Port Based

Byte	1								0							
Bit	7	6	5	4	3	2	1	0	7	6	5	4	3	2	1	0
Port	X7	X7	X6	X6	X5	X5	X4	X4	X3	X3	X2	X2	X1	X1	X0	X0
Pin	2	4	2	4	2	4	2	4	2	4	2	4	2	4	2	4
Chan- nel	17	07	16	06	15	05	14	04	13	03	12	02	11	01	10	00

Tab. 12-25: Port Based

Pin Based

Byte	1								0							
Bit	7	6	5	4	3	2	1	0	7	6	5	4	3	2	1	0
Port	X7	X6	X5	X4	X3	X2	X1	X0	X7	X6	X5	X4	X3	X2	X1	X0
Pin	2	2	2	2	2	2	2	2	4	4	4	4	4	4	4	4
Chan- nel	17	16	15	14	13	12	11	10	07	06	05	04	03	02	01	00

Tab. 12-26: Pin Based



NOTICE

The tables for Port and Pin Based are also applicable to Digital Input Qualifier, Digital Output Qualifier and Digital Output.

12.2.2 DI Qualifier

The Digital Input Qualifiers inform you quickly about the integrity of the input signal.

Bit value	Description
0	Invalid
1	Valid



NOTICE

The bit order depends on the configuration parameter "Pin_Port_based_IO_Layout". See chap. 12.2.1 "Digital Input"

12.2.3 DO Qualifier

The Digital Output Qualifiers inform you quickly about the integrity of the output signal.

Bit value	Description
0	Invalid
1	Valid



NOTICE

The bit order depends on the configuration parameter "Pin_Port_based_IO_Layout". See chap. 12.2 "Explanation of the process data"

12.2.4 System Status

The system state bit string provides information about the entire device.

Byte	Description
0 ... 3	Bit 0: Bus/sensor supply undervoltage Bit 1: Actuator supply undervoltage Bit 3: External error Bit 4: At least one channel has a sensor short circuit Bit 5: At least one channel has an actuator short circuit Bit 6: At least one channel has an actuator warning Bit 7: At least one analog channel has an error Bit 8: Internal communication error Bit 9: At least one IO-Link channel has an error (except wire break) Bit 10: Bus/sensor supply overvoltage Bit 11: Actuator supply overvoltage Bit 12: At least one IO-Link channel has a wire break Bit 13 ... 31: Reserved, set to 0

Tab. 12-27: System status bit string

12.2.5 IO-Link Port X Status

Byte	Description	Value
0 ... 1	IO-Link Data Status	Bit 0 - 4: reserved Bit 5: DevCom, is set when a device is detected and is in the PREOPERATE or OPERATE state. It is reset if no device is present. Bit 6: DevErr, is set when an error or warning has occurred that is assigned to either a device or a port. It is reset when there is no error or warning. Bit 7: PQ, is set when valid process data is exchanged between master and device. It is reset if the process data is not valid.
2 ... 3	Vendor ID of connected IO-Link device	
4 ... 7	Device ID of connected IO-Link device	

Tab. 12-28: IO-Link Port X Status

12.2.6 Diagnostic Buffer

The diagnostic buffer consists of an array of diagnostic structures and has a length of 8 structures. A diagnostic structure has the size of 8 bytes. This gives a total length of the diagnostic buffer of 64 bytes.



NOTICE

For further information on a diagnostic structure, please refer to chap. 9.2.1 "Diagnostics structure in the control system"

12.2.7 Digital Output



NOTICE

The order of the digital output data depends on the configuration parameter "Pin_Port_based_IO_Layout". See chap. 12.2.1 "Digital Input"

12.3 Accessories

12.3.1 System components

Description	Art.-No.
Screw Plug M12 Metal	996049
Plastic M12 screw plug, VE10	58627
Ground strap 4 mm ² 100 mm for M4	4000-71001-0410004
Grounding strap screw-down set M4	4000-71003-0101604
Designation label 20x8 in a set (20 pcs)	55318

12.3.2 Tools

Designation	Art.-No.
6-part screwdriver set	7000-98001-0000000
M12 torque wrench set, AF 13	7000-99102-0000000



Fig. 12-1: Installation wrench



PRODUCTS AND ACCESSORIES

You will find a wide range of products in our catalog or in our Murrelektronik online shop shop.murrelektronik.com

12.4 Glossary

Term	Meaning
EtherNet/IP	<p>Ethernet Industrial Protocol</p> <p>Open standard for industrial networks that supports both cyclic and acyclic transfer of messages and uses standard Ethernet communication chips and physical media.</p>
CIP	<p>Common Industrial Protocol</p> <p>The Common Industrial Protocol is an application protocol used in automation technology. It supports the transition between fieldbuses and industrial Ethernet and IP networks. This industrial protocol uses EtherNet/IP in the application layer as interface between fieldbus and control, I/O, etc.</p>
DHCP	<p>Dynamic Host Configuration Protocol</p> <p>DHCP allows a server to dynamically distribute IP address and configuration information to clients. Normally, the DHCP server provides at least the following basic information to the client:</p> <ul style="list-style-type: none"> - IP address - Subnet mask - Standard gateway
EDS	<p>Electronic Data Sheet</p> <p>An EDS file is an external file that contains information for a module. It provides necessary information for access to and change of configurable parameters of a module.</p>
Ethernet frame	<p>In each Ethernet frame (data package), there are addresses of transmitter (source) and receiver (target). When a frame is received, the receiving unit of a receiving station compares the MAC target address with its own MAC address. When the addresses match, the receiving unit forwards the contents of the frame to a superior layer. If they do not match, the frame is discarded.</p>
IO-Link IOL	<p>Standardized communication system to connect intelligent sensors and actuators to an automation system</p>
IP	<p>Internet Protocol</p> <p>Protocol used for transferring data within a network, e.g. internet or intranet, from one computer to another. Each computer in the network can be clearly identified by means of its IP address. If data is sent from one computer to another, it is subdivided into small information packages containing each transmitter and receiver addresses. These packages can be sent over the network using different routes and arrive at their destination in a different order than the sequence of sending. Another protocol, the transmission control protocol [TCP], then restores the original order.</p>
MAC address	<p>Media Access Control Address</p> <p>Hardware address of network components used for clearly identifying devices in a network.</p>
ODVA	<p>ODVA is an international association for open and compatible information and communication technologies in automation systems.</p> <p>e.g. EtherNet/IP, DeviceNet, CompoNet and ControlNet,....</p>
RPI	<p>Requested packet interval</p> <p>The interval at which an EtherNet/IP target sends process data to the scanner.</p>

13 Legal notes

Disclaimer

Murrelektronik GmbH has reviewed the contents of this technical documentation for conformity with the described hardware and software. It is possible that certain details may not be correct. For this reason, we make no warranty regarding the accuracy of this technical documentation, and assume no liability for any errors, in particular full conformity. This exclusion of liability shall not apply if the damage was caused deliberately and/or due to gross negligence, nor does it cover any claims based on the German Product Liability Act. Should a major contractual obligation have been violated negligently, the liability of Murrelektronik GmbH shall be limited to typically occurring damage.

We reserve the right to make technical alterations and amend the content of this documentation. We recommend to regularly check whether this documentation has been updated because corrections that might be required due to technical modifications will be included by Murrelektronik GmbH at regular intervals. Please contact us if you would like to suggest any improvements.

Copyright

It is prohibited to transfer or photocopy the documentation either in paper or in digital form, reuse or divulge its contents unless otherwise expressly permitted by Murrelektronik GmbH or in conjunction with the production of documentation for third-party products that contain products made by Murrelektronik GmbH. Compensation will be claimed if our copyright is violated. All rights reserved, particularly in the event of a patent being granted or a utility model being registered.

Usage rights

Murrelektronik GmbH grants its customers a non-exclusive right revocable at any time and for an indefinite period of time to use this technical documentation to create their own technical documentation. For this purpose, the documentation produced by Murrelektronik GmbH may be changed in parts, or amended, or copied, and transferred to the customer's users as part of the customer's own technical documentation on paper or on electronic media. In this case, the customers shall bear sole responsibility for the correctness of the contents of the technical documentation produced by them.

If the technical documentation is integrated in part, or in full in the customer's technical documentation, the customer shall refer to the copyright of Murrelektronik GmbH. All safety instructions must be included.

Although the customer is obliged to make reference to the copyright of Murrelektronik GmbH, provided the technical documentation of Murrelektronik GmbH is used, the customers shall market and/or use the technical documentation on their sole responsibility. The reason is that we have no influence on changes or applications of the technical documentation and even minor changes to the initial product or deviations in the intended applications may render incorrect the specifications contained in the technical documentation. For this reason, the customer is obliged to label the technical documentation provided by Murrelektronik GmbH if and the extent to which the documentation is amended by the customer. The customers shall undertake to exempt Murrelektronik from claims for damages of third parties if the latter are attributable to any defects in the documentation. This shall not apply to damage to the rights of third parties caused deliberately or by gross negligence.

The customers shall be entitled to use the company brands of Murrelektronik GmbH exclusively for their product advertising, but only inasmuch as the products of Murrelektronik GmbH are integrated into the products marketed by the customers. When using Murrelektronik GmbH brands, the customers shall so state in an adequate manner.



Murrelektronik GmbH | Falkenstraße 3 | 71570 Oppenweiler | GERMANY
☎ +49 7191 47-0 | 📠 +49 7191 47-491 000 | info@murrelektronik.com
www.murrelektronik.com

The information in the manual has been compiled with utmost care. Liability for the correctness, completeness and topicality of the information is restricted to gross negligence.