

STRIDE® FIELD I/O MODULES

DISCRETE COMBO MODULE: 8-POINT IN, 4-POINT OUT (PN# SIO-MB12CDR)

FEATURES

- Interface Ethernet 10/100 Base-T, Modbus TCP Server
- 8 digital inputs
- 4 relay outputs (SPDT Form C)
- Integrated web server to acquire the status of the digital inputs and drive the digital outputs via browser
- Remotely configurable
- Connection by removable screw terminals
- LED signaling for Link/Act Ethernet, power supply
- LED signaling for digital input and output states
- Galvanic isolation
- UL listed / CE mark
- In compliance with EN-50022 DIN rail mounting



GENERAL DESCRIPTION

The SIO-MB12CDR device is a Modbus TCP server with 8 digital input channels and 4 SPDT relay outputs. For the digital inputs, up to four 32-bit counters are available with measurement frequency of up to 300Hz. The Ethernet interface allows reading and writing the values of the internal registers of the device in real time. The built-in Web Server allows remote visualization, acquisition of the digital input states, driving of the relay outputs and access to the configuration parameters. Signal LEDs for Ethernet activity, input state, output state and power supply allow direct monitoring of the system. Connections are made by removable screw terminals (inputs, outputs and power supply) and RJ45 plug (Ethernet). The SIO-MB12CDR is in compliance with Directive UL 61010-1 for the US market and with Directive CSA C22.2 No 61010-1 for the Canadian market. The device has full electrical isolation between the lines, providing protection against the effects of ground loops existing in industrial applications. It is housed in a tough self-extinguishing plastic enclosure which, thanks to its thin 22.5 mm profile, allows high-density mounting on EN-50022 standard DIN rail.

USER INSTRUCTIONS

Before installing the device, please read the "Installation Instructions" section. To configure the device in INIT mode, refer to the User Guide. Connect the INIT terminal to the V- terminal (refer to the User Guide). Connect power supply, Ethernet, digital inputs and relay outputs as shown in the "Wiring" section. The LED states indicate the working condition of the device; see the "Front Panel LEDs" table to verify the device working state. Instructions for configuration and calibration operations are contained in the User Guide. To simplify handling or replacing of the device, it is possible to remove the wired terminals even with the device powered.

TECHNICAL SPECIFICATIONS (typical @ 25°C, nominal conditions)

NETWORK CONNECTIVITY		DIGITAL INPUTS		POWER SUPPLY	
Standard	In compliance with IEEE 802.3	Channels	8	Power Supply Voltage	10-30VDC To maintain a UL 508 panel listing use a Class 2 power supply.
Network Interface	Ethernet 10/100Base-T	Input Voltage (Bipolar)		Reverse Polarity Protection	60VDC max
Protocol	Modbus TCP	OFF State	0-3V	Current Consumption	290mA max (2)
Max. Cable Length	100m [328ft]	ON State	10-30V	ISOLATION	
Number of Sockets	16 simultaneous Modbus TCP connections	Impedance	4.7 kΩ	Power Supply / Ethernet	1500VAC, 50Hz, 1 min
		Sample Time	5ms	Inputs / Power Supply	1500VAC, 50Hz, 1 min
		Number of Counters	4	Inputs / Ethernet	1500VAC, 50Hz, 1 min
		Counters Register Bit Length	32 bit	Input / Output	1500VAC, 50Hz, 1 min
		Counters Frequency	Up to 300Hz	ENVIRONMENTAL CONDITIONS	
		Minimum Pulse Width	1ms	Operating Temperature	-10°C to +60°C [+14°F to +140°F]
		DIGITAL OUTPUTS		UL Operating Temperature	-10°C to +40°C [+14°F to +104°F]
		Channels	4	Storage Temperature	-40°C to +85°C [-40°F to +185°F]
		Type	SPDT relay	Humidity (non-condensing)	0 to 90%
		Max. Switching Power with Resistive Load, per Contact	2A @ 250VAC 2A @ 30VDC	Maximum Altitude	2000m [6500ft]
		Max. Voltage	250VAC (50/60Hz) 30VDC	Installation	Indoor
		Dielectric Strength Between Contacts	1000VAC, 50Hz, 1 min.	Pollution Degree	2
		Dielectric Strength Between Coil and Contacts	4000VAC, 50Hz, 1 min.	CONNECTIONS	
				Ethernet	RJ-45
				Inputs/Outputs/Power Supply	Removable screw terminals
				MECHANICAL SPECIFICATIONS	
				Material	Self-extinguishing plastic
				IP Code	IP20
				Wire diameter	0.8 to 2.1 mm ² / AWG 14-18
				Tightening Torque	0.5 N·m [4.4 in·lb]
				Mounting	In compliance with DIN rail standard EN-50022
				Weight	About 190g [6.7 oz]
				EMC (for industrial environments)	
				Immunity	EN 61000-6-2
				Emission	EN 61000-6-4
				UL	
				US Standard	UL 61010-1
				Canadian Standard	CSA C22.2 No 61010-1
				CCN	NRAQ/NRAQ7
				UL Type Designation	Open Type device
				Classification	Industrial Control Equipment
				File Number	E157382

Please refer to the User Guide for more information, including the complete Modbus address list. Access the user guide by visiting <https://www.automationdirect.com/pn/doc/manual/SIO-MB12CDR> or scan the QR code below.



INSTALLATION INSTRUCTIONS

The device shall be mounted on DIN rail in a vertical and upright orientation. For optimum operation and long life follow these instructions: When the devices are installed side by side it is necessary to separate them by the following minimum distances:

- 10 mm if UL certification is required.
- 5 mm if UL certification is not required.

Make sure that sufficient air flow is provided for the device. Avoid placing raceways or other objects where they could obstruct the ventilation slits. Avoid mounting the devices above appliances generating heat; ideally locate them in the lower part of the panel.

Install the device in a place without vibrations.

Avoid routing conductors near power signal cables (motors, induction ovens, inverters, etc.). Use shielded cable for connecting signals; ground shield at one end only.

DEFAULT CONFIGURATION

- IP Address: 192.168.1.100
- Modbus Address: 1
- Default user name: admin
- Default password: password

MODBUS REGISTERS		
Register	Description	Access
40002	Firmware [0]	RO
40003	Firmware [1]	RO
40004	-Reserved-	RO
40005	-Reserved-	RO
40007	Node ID	R/W
40011	System Flags	R/W
40012	Power Up / Safe	R/W
40013	Watchdog timer	R/W
40031	Digital Outputs	R/W
40032	Digital Inputs	RO
40033	Digital Inputs Rise Latch	R/W
40034	Digital Inputs Fall Latch	R/W
40035	Frequency, Digital Input 0	RO
40036	Frequency, Digital Input 1	RO
40037	Frequency, Digital Input 2	RO
40038	Frequency, Digital Input 3	RO
40039	32-bit Counter, Digital Input 0	R/W
40041	32-bit Counter, Digital Input 1	R/W
40043	32-bit Counter, Digital Input 2	R/W
40045	32-bit Counter, Digital Input 3	R/W

OUTPUTS PINOUT		
Pin	Description	Channel
1	N.C.	OUT 0
2	COM0	
3	N.O.	OUT 1
4	N.C.	
5	COM1	OUT 2
6	N.O.	
7	N.C.	OUT 3
8	COM2	
9	N.O.	OUT 3
10	N.C.	
11	COM3	
12	N.O.	

INPUTS PINOUT	
Pin	Description
E	COM
F	IN0
G	IN1
H	IN2
I	IN3
J	IN4
L	IN5
M	IN6
N	IN7

FRONT PANEL LEDS			
LED	COLOR	STATE	DESCRIPTION
PWR	GREEN	ON	Device powered
		OFF	Device not powered
		BLINK	Watchdog alarm
STS	YELLOW	OFF	Device in RUN mode
		BLINK	Device in INIT mode
In	RED	ON	Digital Input High Level (1)
		OFF	Digital Input Low Level (0)
On	RED	ON	Digital Output High Level (1)
		OFF	Digital Output Low Level (0)

POWER SUPPLY (1)

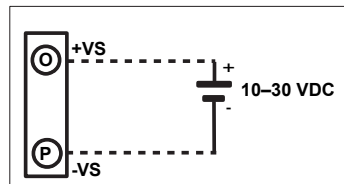

INIT FUNCTION (2)

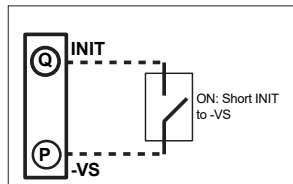

NOTE: (1) To maintain the UL listing use a Class 2 or SELV and limited energy power supply.

(2) See User Guide for instructions on using the INIT feature.

DIGITAL INPUTS

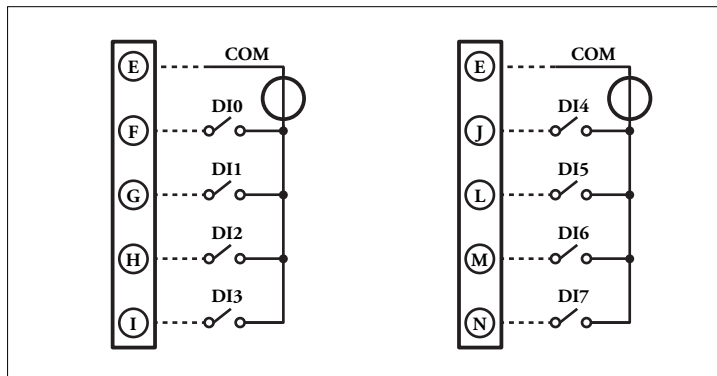

NOTE: The input channels are not isolated from one another.

RELAY OUTPUTS

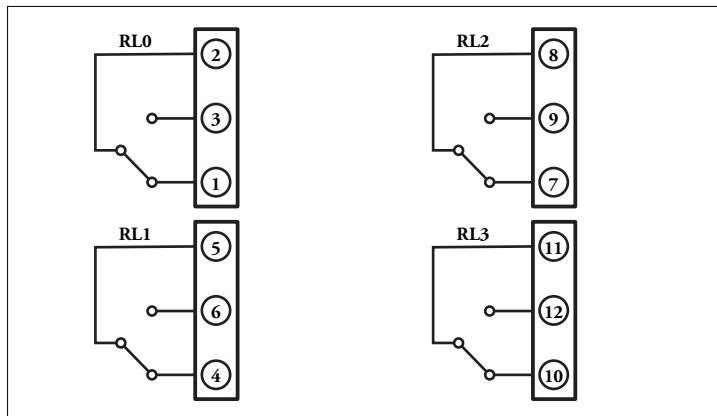

MECHANICAL DIMENSIONS

MM [IN]

