

STRIDE® FIELD I/O MODULES

TEMPERATURE INPUT MODULE: THERMOCOUPLE, 8-CHANNEL IN (PN# SIO-MB08THMS)

FEATURES

- Interface Ethernet 10/100 Base-T, Modbus TCP Server
- 8 input channels isolated in pairs
- Input configurable for mV and Tc
- Integrated web server to acquire the status of the analog inputs via browser
- Remotely configurable
- Connection by removable screw terminals
- LED signaling for Link/Act Ethernet, power supply
- Galvanic isolation
- UL listed / CE mark
- In compliance with EN-50022 DIN rail mounting



GENERAL DESCRIPTION

The SIO-MB08THMS device is a Modbus TCP server that can convert up to 8 analog signals applied to the inputs into engineering units in digital format. The inputs can be connected to thermocouples or sensors having mV output.

The input channels are electrically isolated in pairs.

The device guarantees high accuracy and a stable measurement versus time and temperature. The device is equipped with a selectable Watchdog Timer system. The Ethernet interface allows reading and writing the values of the internal registers of the device in real time.

Signal LEDs for Ethernet activity and power supply allow direct monitoring of the system.

The built-in Web Server allows remote visualization, acquisition of the analog inputs and access to the configuration parameters.

Connections are made by removable screw terminals (inputs and power supply) and RJ45 plug (Ethernet).

The SIO-MB08THMS is in compliance with Directive UL 61010-1 for the US market and with Directive CSA C22.2 No 61010-1 for the Canadian market.

The device has full electrical isolation between the lines, providing protection against the effects of ground loops existing in industrial applications.

It is housed in a tough self-extinguishing plastic enclosure which, thanks to its thin 22.5 mm profile, allows high-density mounting on EN-50022 standard DIN rail.

USER INSTRUCTIONS

Before installing the device, please read the "Installation Instructions" section.

To configure the device in INIT mode, refer to the User Guide. Connect power supply, Ethernet and analog inputs as shown in the "Wiring" section. The LED states indicate the working condition of the device; see the "Front Panel LEDs" table to verify the device working state.

Instructions for configuration and calibration operations are contained in the User Guide.

To simplify handling or replacing of the device, it is possible to remove the wired terminals even with the device powered.

TECHNICAL SPECIFICATIONS (typical @ 25°C, nominal conditions)

NETWORK CONNECTIVITY		
Standard	In compliance with IEEE 802.3	
Network Interface	Ethernet 10/100Base-T	
Protocol	Modbus TCP	
Max. Cable Length	100m [328ft]	
Number of Sockets	16 simultaneous Modbus TCP connections	
INPUTS		
Input Type	Min	Max
Voltage mV	-250mV	+250mV
Thermocouple		
J	-210°C	+1200°C
K	-210°C	+1372°C
R	-50°C	+1767°C
S	-50°C	+1767°C
B	+400°C	+1825°C
E	-210°C	+1000°C
T	-210°C	+400°C
N	-210°C	+1300°C

I/O SPECIFICATIONS		
Input Accuracy (1)		The greater of ±0.05% full scale and ±5µV
Linearity (1)	mV	±0.1% full scale
	Tc	±0.2% full scale
Max. Cold Junction Compensation Error (CJC)		±2°C
Input Impedance	mV	≥ 1MΩ
	Tc	
Lead Wire Resistance Influence(1)	mV	< 0.8 µV/Ohm
	Tc	
Thermal Drift (1) Full Scale		±0.005%/°C
Thermal Drift (CJC) Full Scale		±0.02%/°C
Sampling Time		150ms (8 channels)
Warm-up Time		3 min.

(1) Referred to input Span (difference between maximum and minimum values).

POWER SUPPLY	
Power Supply Voltage	14-30VDC To maintain a UL 508 panel listing use a Class 2 power supply.
Reverse Polarity Protection	60VDC max
Current Consumption	150mA max (2)
ISOLATION	
Power Supply / Ethernet	1500VAC, 50Hz, 1 min
Inputs / Power Supply	1500VAC, 50Hz, 1 min
Inputs / Ethernet	1500VAC, 50Hz, 1 min
Input / Input	1500VAC, 50Hz, 1 min
ENVIRONMENTAL CONDITIONS	
Operating Temperature	-10°C to +60°C [+14°F to +140°F]
UL Operating Temperature	-10°C to +40°C [+14°F to +104°F]
Storage Temperature	-40°C to +85°C [-40°F to +185°F]
Humidity (non-condensing)	0 to 90%
Maximum Altitude	2000m [6500ft]
Installation	Indoor
Pollution Degree	2
CONNECTIONS	
Ethernet	RJ-45
Inputs / Power Supply	Removable screw terminals
MECHANICAL SPECIFICATIONS	
Material	Self-extinguishing plastic
IP Code	IP20
Wire diameter	0.8 to 2.1 mm ² / AWG 14-18
Tightening Torque	0.5 N·m [4.4 in·lb]
Mounting	In compliance with DIN rail standard EN-50022
Weight	About 160g [5.6 oz]
EMC (for industrial environments)	
Immunity	EN 61000-6-2
Emission	EN 61000-6-4
UL	
US Standard	UL 61010-1
Canadian Standard	CSA C22.2 No 61010-1
CCN	NRAQ/NRAQ7
UL Type Designation	Open Type device
Classification	Industrial Control Equipment
File Number	E1573B2

Please refer to the User Guide for more information, including the complete Modbus address list. Access the user guide by visiting <https://www.automationdirect.com/pn/doc/manual/SIO-MB08THMS> or scan the QR code below.



INSTALLATION INSTRUCTIONS

The device shall be mounted on DIN rail in a vertical and upright orientation. For optimum operation and long life follow these instructions: When the devices are installed side by side it is necessary to separate them by the following minimum distances:

- 10 mm if UL certification is required.
- 5 mm if UL certification is not required.

Make sure that sufficient air flow is provided for the device. Avoid placing raceways or other objects where they could obstruct the ventilation slits. Avoid mounting the devices above appliances generating heat; ideally locate them in the lower part of the panel.

Install the device in a place without vibrations.

Avoid routing conductors near power signal cables (motors, induction ovens, inverters, etc.). Use shielded cable for connecting signals; ground shield at one end only.

DEFAULT CONFIGURATION

- IP Address: 192.168.1.100
- Modbus Address: 1
- Default user name: admin
- Default password: password

MODBUS REGISTERS

Register	Description	Access
40002	Firmware [0]	RO
40003	Firmware [1]	RO
40004	-Reserved-	RO
40005	-Reserved-	RO
40007	Node ID	R/W
40011	System Flags	R/W
40013	Watchdog timer	R/W
40031	Input Type, Channels 1-0	R/W
40032	Input Type, Channels 3-2	R/W
40033	Input Type, Channels 5-4	R/W
40034	Input Type, Channels 7-6	R/W
40041	Analog Input (0) - Ch0	RO
40042	Analog Input (1) - Ch1	RO
40043	Analog Input (2) - Ch2	RO
40044	Analog Input (3) - Ch3	RO
40045	Analog Input (4) - Ch4	RO
40046	Analog Input (5) - Ch5	RO
40047	Analog Input (6) - Ch6	RO
40048	Analog Input (7) - Ch7	RO
40050	Break Status	RO
41218	Degree Units Channel 0	R/W
41219	Degree Units Channel 1	R/W
41220	Degree Units Channel 2	R/W
41221	Degree Units Channel 3	R/W
41222	Degree Units Channel 4	R/W
41223	Degree Units Channel 5	R/W
41224	Degree Units Channel 6	R/W
41225	Degree Units Channel 7	R/W
41241	Offset Channel 0	R/W
41242	Offset Channel 1	R/W
41243	Offset Channel 2	R/W
41244	Offset Channel 3	R/W
41245	Offset Channel 4	R/W
41246	Offset Channel 5	R/W
41247	Offset Channel 6	R/W
41248	Offset Channel 7	R/W

PINOUT

Pin	Description	Channel
1	V0+	IN 0 / IN 1
2	COM0	
3	V1+	IN 2 / IN 3
4	COM0	
5	V2+	IN 4 / IN 5
6	COM1	
7	V3+	IN 6 / IN 7
8	COM1	
9	V4+	IN 4 / IN 5
10	COM2	
11	V5+	IN 6 / IN 7
12	COM2	
13	V6+	IN 6 / IN 7
14	COM3	
15	V7+	IN 6 / IN 7
16	COM3	

FRONT PANEL LEDS

LED	COLOR	STATE	DESCRIPTION
PWR	GREEN	ON	Device powered
		OFF	Device not powered
		BLINK	Watchdog alarm
STS	YELLOW	OFF	Device in RUN mode
		BLINK	Device in INIT mode

POWER SUPPLY (1)

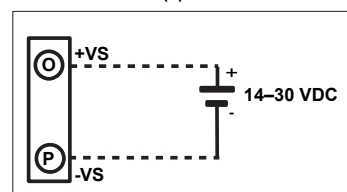

INIT FUNCTION (2)

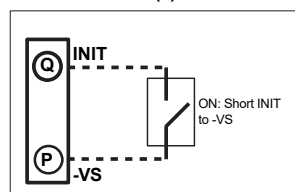

NOTE: (1) To maintain the UL listing use a Class 2 or SELV and limited energy power supply.

(2) See User Guide for instructions on using the INIT feature.

ANALOG INPUTS

VOLTAGE

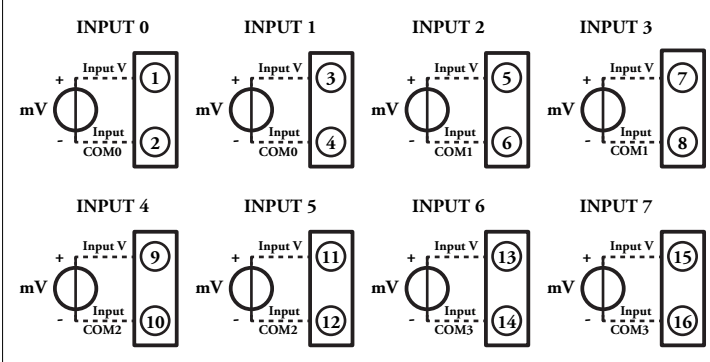

THERMOCOUPLE

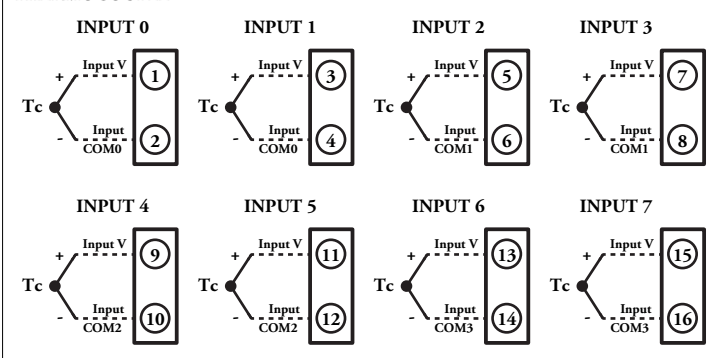

NOTES:

"COM0", "COM1", "COM2" and "COM3" are each isolated commons.

Terminals "2" and "4" are internally connected to negative reference COM0.

Terminals "6" and "8" are internally connected to negative reference COM1.

Terminals "10" and "12" are internally connected to negative reference COM2.

Terminals "14" and "16" are internally connected to negative reference COM3.

MECHANICAL DIMENSIONS

MM [IN]

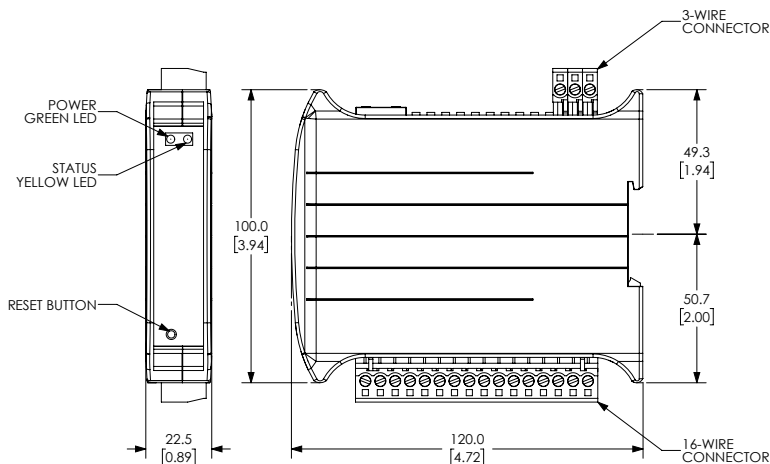

ISOLATED ELECTRICAL SUBSYSTEMS

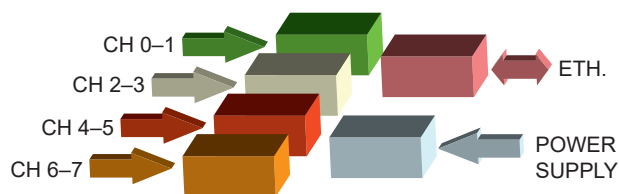

Each block represents a subsystem which is isolated from each other subsystem.

