

STRIDE® FIELD I/O MODULES

TEMPERATURE INPUT MODULE: RTD, 4-CHANNEL (PN# SIO-MB04RTDS)

FEATURES

- Interface Ethernet 10/100 Base-T, Modbus TCP Server
- 4 isolated input channels
- Each input configurable for RTD, Resistance or Potentiometer
- Integrated web server to acquire the status of the analog inputs via browser
- Remotely configurable
- Connection by removable screw terminals
- LED signaling for Link/Act Ethernet, power supply
- Galvanic isolation
- UL listed / CE mark
- In compliance with EN-50022 DIN rail mounting



GENERAL DESCRIPTION

The SIO-MB04RTDS device is a Modbus TCP server that can convert up to 4 analog signals applied to the inputs into engineering units in digital format. The inputs can be connected to two-wire or three-wire RTD or resistance sensors.

The input channels are electrically isolated from each other.

The device guarantees high accuracy and a stable measurement versus time and temperature. The device is equipped with a selectable Watchdog Timer system. The Ethernet interface allows reading and writing the values of the internal registers of the device in real time.

Signal LEDs for Ethernet activity and power supply allow direct monitoring of the system.

The built-in Web Server allows remote visualization, acquisition of the analog inputs and access to the configuration parameters.

Connections are made by removable screw terminals (inputs and power supply) and RJ45 plug (Ethernet).

The SIO-MB04RTDS is in compliance with Directive UL 61010-1 for the US market and with Directive CSA C22.2 No 61010-1 for the Canadian market.

The device has full electrical isolation between the lines, providing protection against the effects of ground loops existing in industrial applications.

It is housed in a tough self-extinguishing plastic enclosure which, thanks to its thin 22.5 mm profile, allows high-density mounting on EN-50022 standard DIN rail.

USER INSTRUCTIONS

Before installing the device, please read the "Installation Instructions" section.

To configure the device in INIT mode, refer to the User Guide. Connect power supply, Ethernet and analog inputs as shown in the "Wiring" section. The LED states indicate the working condition of the device; see the "Front Panel LEDs" table to verify the device working state.

Instructions for configuration and calibration operations are contained in the User Guide.

To simplify handling or replacing of the device, it is possible to remove the wired terminals even with the device powered.

TECHNICAL SPECIFICATIONS (typical @ 25°C, nominal conditions)

NETWORK CONNECTIVITY	
Standard	In compliance with IEEE 802.3
Network Interface	Ethernet 10/100Base-T
Protocol	Modbus TCP
Max. Cable Length	100m [328ft]
Number of Sockets	16 simultaneous Modbus TCP connections
INPUTS	
Input Type	Min Max
RTD 2 or 3 wire	
Pt100	-200°C 850°C
Pt1000	-200°C 200°C
Ni100	-60°C 180°C
Ni1000	-60°C 150°C
Resistance 2 or 3 wire	
Low	0Ω 500Ω
High	0Ω 2000Ω
Pot. (nominal value)	20Ω 50kΩ

I/O SPECIFICATIONS		
Input Accuracy (1)	RTD	±0.05% full scale
	Resistance	±0.05% full scale
	Potentiometer	±0.05% full scale
Linearity (1)	RTD	±0.1% full scale
Lead Wire Resistance Influence(1)		RTD/res. 3 wires (50Ω max balanced) ±0.05% full scale/Ω
RTD Excitation Current		0.370 mA typical
Thermal Drift (1) Full Scale		±0.01%/°C
Sampling Time		150ms (4 channels)
Warm-up Time		3 min.

(1) Referred to input Span (difference between maximum and minimum values).

POWER SUPPLY	
Power Supply Voltage	14-30VDC To maintain a UL 508 panel listing use a Class 2 power supply.
Reverse Polarity Protection	60VDC max
Current Consumption	150mA max (2)
ISOLATION	
Power Supply / Ethernet	1500VAC, 50Hz, 1 min
Inputs / Power Supply	1500VAC, 50Hz, 1 min
Inputs / Ethernet	1500VAC, 50Hz, 1 min
Input / Input	1500VAC, 50Hz, 1 min
ENVIRONMENTAL CONDITIONS	
Operating Temperature	-10°C to +60°C [+14°F to +140°F]
UL Operating Temperature	-10°C to +40°C [+14°F to +104°F]
Storage Temperature	-40°C to +85°C [-40°F to +185°F]
Humidity (non-condensing)	0 to 90%
Maximum Altitude	2000m [6500ft]
Installation	Indoor
Pollution Degree	2
CONNECTIONS	
Ethernet	RJ-45
Inputs / Power Supply	Removable screw terminals
MECHANICAL SPECIFICATIONS	
Material	Self-extinguishing plastic
IP Code	IP20
Wire diameter	0.8 to 2.1 mm ² / AWG 14-18
Tightening Torque	0.5 N·m [4.4 in·lb]
Mounting	In compliance with DIN rail standard EN-50022
Weight	About 160g [5.6 oz]
EMC (for industrial environments)	
Immunity	EN 61000-6-2
Emission	EN 61000-6-4
UL	
US Standard	UL 61010-1
Canadian Standard	CSA C22.2 No 61010-1
CCN	NRAQ/NRAQ7
UL Type Designation	Open Type device
Classification	Industrial Control Equipment
File Number	E157382

Please refer to the User Guide for more information, including the complete Modbus address list. Access the user guide by visiting <https://www.automationdirect.com/pn/doc/manual/SIO-MB04RTDS> or scan the QR code below.



INSTALLATION INSTRUCTIONS

The device shall be mounted on DIN rail in a vertical and upright orientation. For optimum operation and long life follow these instructions: When the devices are installed side by side it is necessary to separate them by the following minimum distances:

- 10 mm if UL certification is required.
- 5 mm if UL certification is not required.

Make sure that sufficient air flow is provided for the device. Avoid placing raceways or other objects where they could obstruct the ventilation slits. Avoid mounting the devices above appliances generating heat; ideally locate them in the lower part of the panel.

Install the device in a place without vibrations.

Avoid routing conductors near power signal cables (motors, induction ovens, inverters, etc.). Use shielded cable for connecting signals; ground shield at one end only.

DEFAULT CONFIGURATION

- IP Address: 192.168.1.100
- Modbus Address: 1
- Default user name: admin
- Default password: password

MODBUS REGISTERS		
Register	Description	Access
40002	Firmware [0]	RO
40003	Firmware [1]	RO
40004	-Reserved-	RO
40005	-Reserved-	RO
40007	Node ID	R/W
40011	System Flags	R/W
40013	Watchdog timer	R/W
40031	Input Type, Channel 0	R/W
40032	Input Type, Channel 1	R/W
40033	Input Type, Channel 2	R/W
40034	Input Type, Channel 3	R/W
40041	Analog Input (0) - Ch0	RO
40042	Analog Input (1) - Ch1	RO
40043	Analog Input (2) - Ch2	RO
40044	Analog Input (3) - Ch3	RO
40050	Break Status	RO
41218	Degree Units Channel 0	R/W
41219	Degree Units Channel 1	R/W
41220	Degree Units Channel 2	R/W
41221	Degree Units Channel 3	R/W
41241	Offset Channel 0	R/W
41242	Offset Channel 1	R/W
41243	Offset Channel 2	R/W
41244	Offset Channel 3	R/W

PINOUT		
Pin	Description	Channel
1	INO	IN 0
2	REF0	
3	GEN0	
4	N.C.	IN 1
5	IN1	
6	REF1	
7	GEN1	IN 2
8	N.C.	
9	IN2	
10	REF2	IN 3
11	GEN2	
12	N.C.	
13	IN3	
14	REF3	
15	GEN3	
16	N.C.	

FRONT PANEL LEDS			
LED	COLOR	STATE	DESCRIPTION
PWR	GREEN	ON	Device powered
		OFF	Device not powered
		BLINK	Watchdog alarm
STS	YELLOW	OFF	Device in RUN mode
		BLINK	Device in INIT mode

MECHANICAL DIMENSIONS

MM [IN]

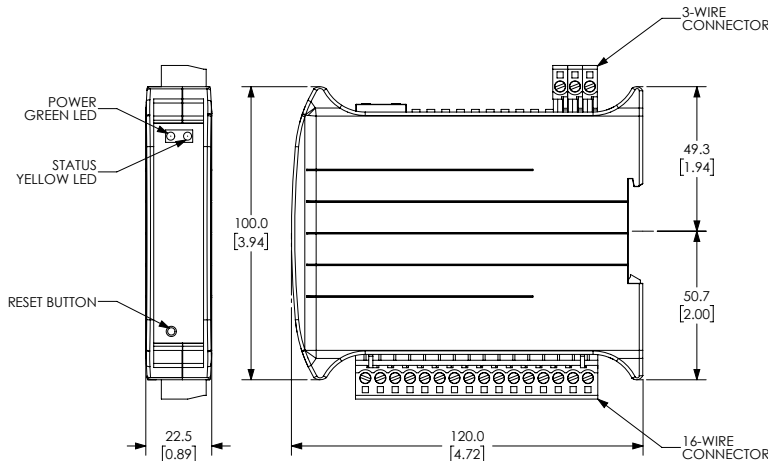

POWER SUPPLY (1)

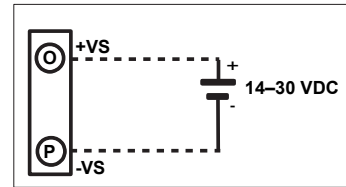

INIT FUNCTION (2)

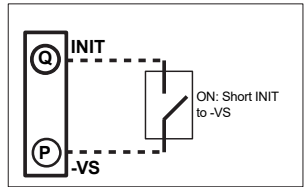

NOTE: (1) To maintain the UL listing use a Class 2 or SELV and limited energy power supply.

(2) See User Guide for instructions on using the INIT feature.

ANALOG INPUTS

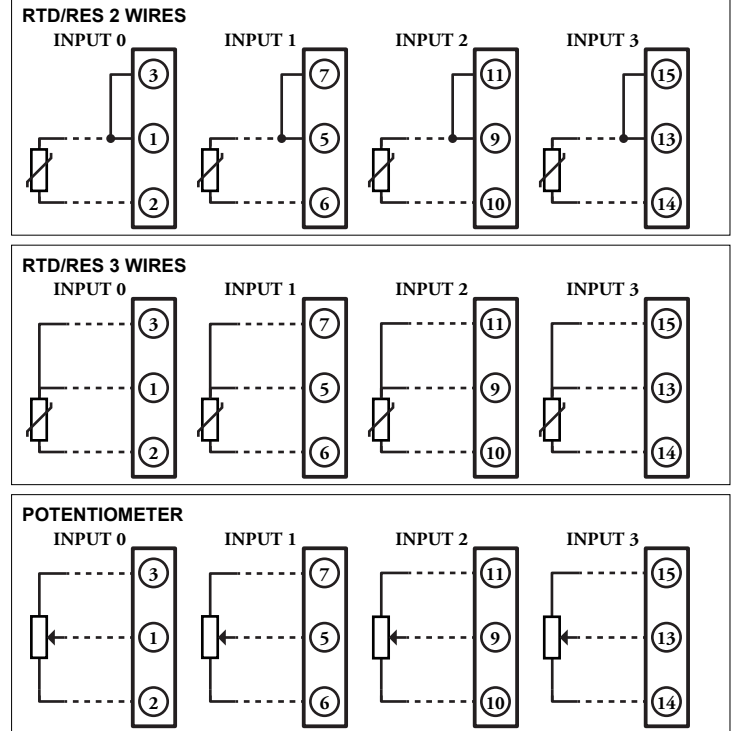

NOTES:

All input channels are isolated.

ISOLATED ELECTRICAL SUBSYSTEMS

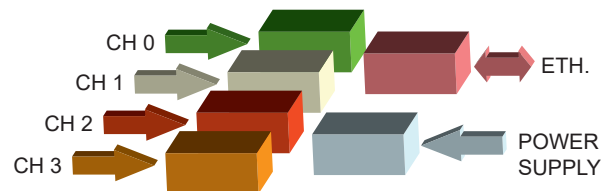

Each block represents a subsystem which is isolated from each other subsystem.

WEEE compliance - These devices comply with the WEEE directive. Dispose of properly.