

⚠ WARNING: This product can expose you to chemicals including: Lead and lead compounds, which is known to the State of California to cause cancer and birth defects or other reproductive harm. For more information go to www.P65Warnings.ca.gov

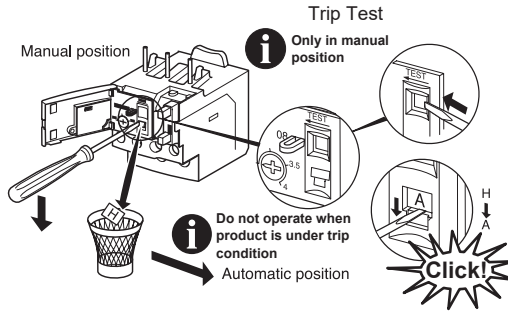

⚠ ⚠ DANGER

HAZARD OF ELECTRIC SHOCK, EXPLOSION, OR ARC FLASH
 Disconnect all power before servicing equipment.
 Failure to follow these instructions will result in death or serious injury.

	(mm ²) AWG	(mm) inch	(N.m) (lb.ft.)
↖	1...2.5 18...14	8 5/16	1.7 15
↙	1...6 18...10	10 3/8	1.7 15

DPER01 to DPER21

	(mm ²) AWG	(mm) inch	(N.m) (lb.ft.)
↖	1...2.5 18...14	8 5/16	1.7 15
↙	2.5...10 14...8	10 3/8	2.5 20

DPER22 to DPER35

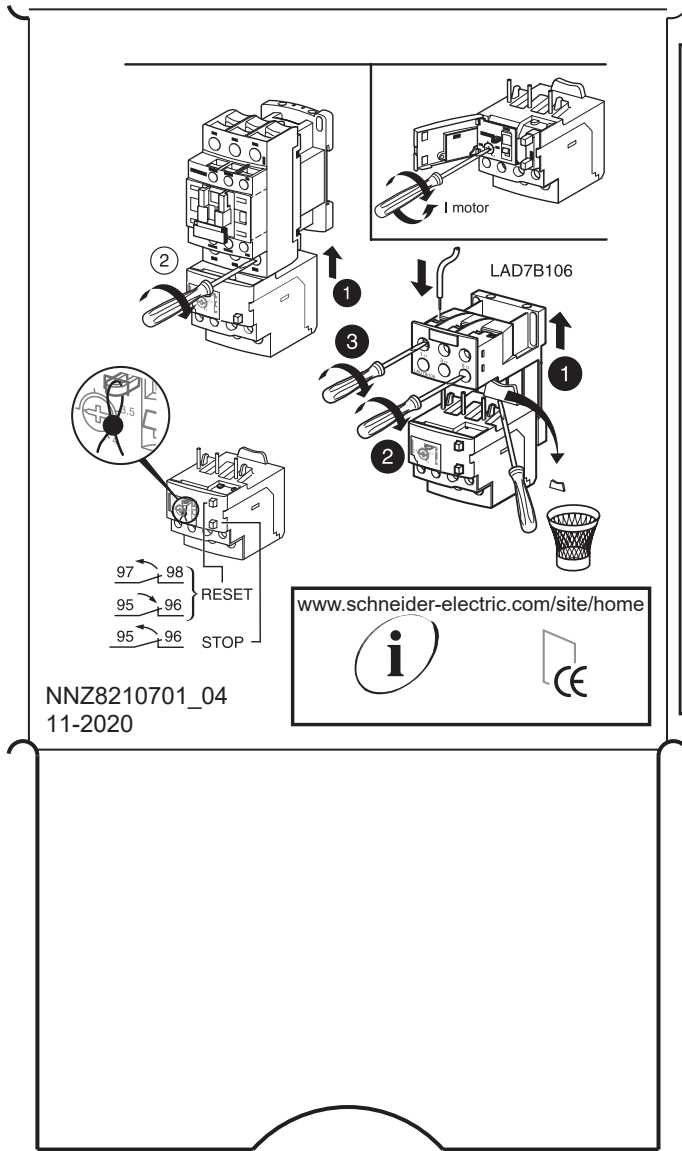

⚠ WARNING

RISK OF FIRE OR ELECTRIC SHOCK (FOR CONTACTOR WITH UL HI-FAULT SHORT CIRCUIT CURRENT RATING).

The opening of the branch-circuit protective device may be an indication that a fault current has been interrupted. To reduce the risk of fire or electrical shock, current-carrying parts and other components of the controller should be examined and replaced if damaged.

Failure to follow these instructions can result in death, serious injury, or equipment damage.