

⚠ ⚠ DANGER / DANGER

HAZARD OF ELECTRIC SHOCK, EXPLOSION OR ARC FLASH
 Disconnect all power before servicing equipment.
Failure to follow these instructions will result in death or serious injury.

RISQUE D'ÉLECTROCUTION, D'EXPLOSION OU D'ÉCLAIR D'ARC ÉLECTRIQUE
 Coupez toutes les alimentations avant de travailler sur cet appareil.
Si ces directives ne sont pas respectées, cela entraînera la mort ou des blessures graves.

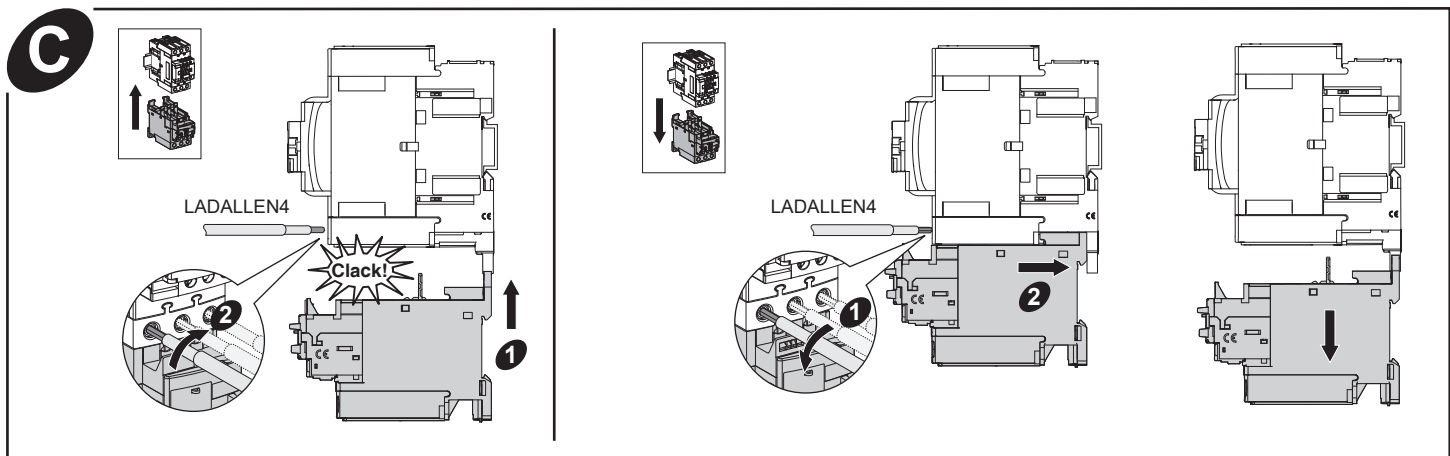

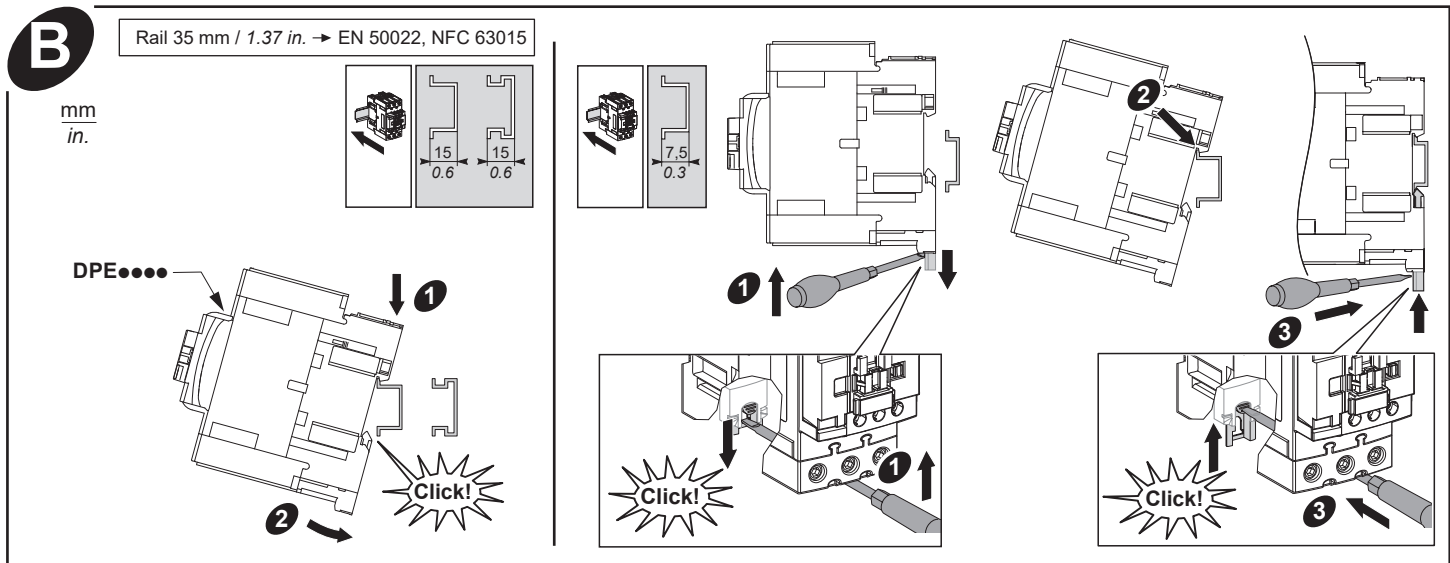
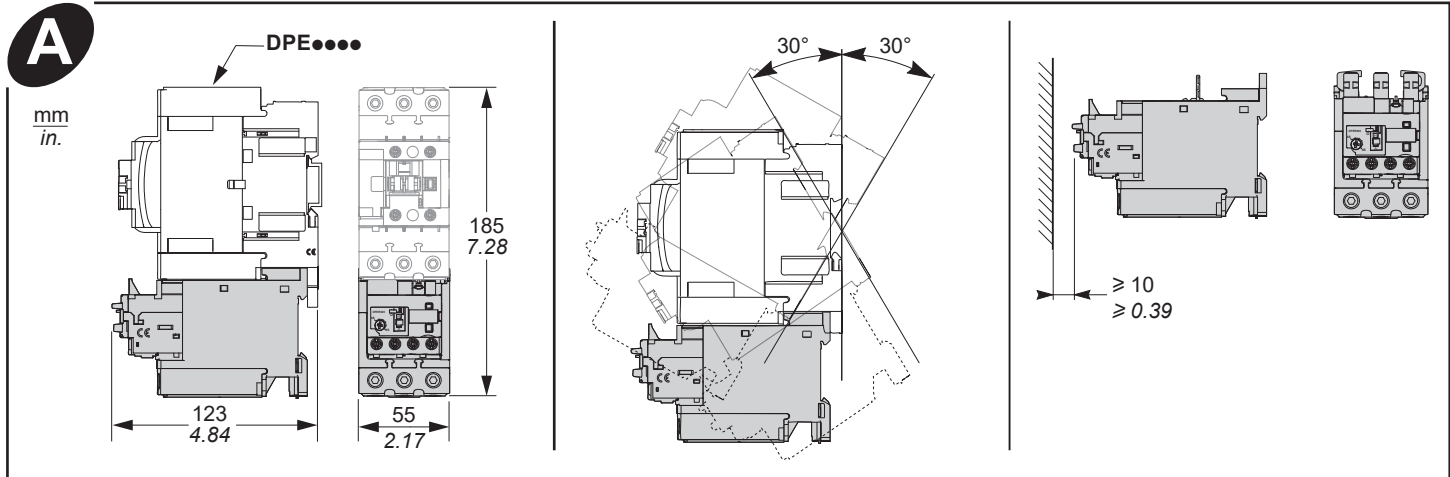
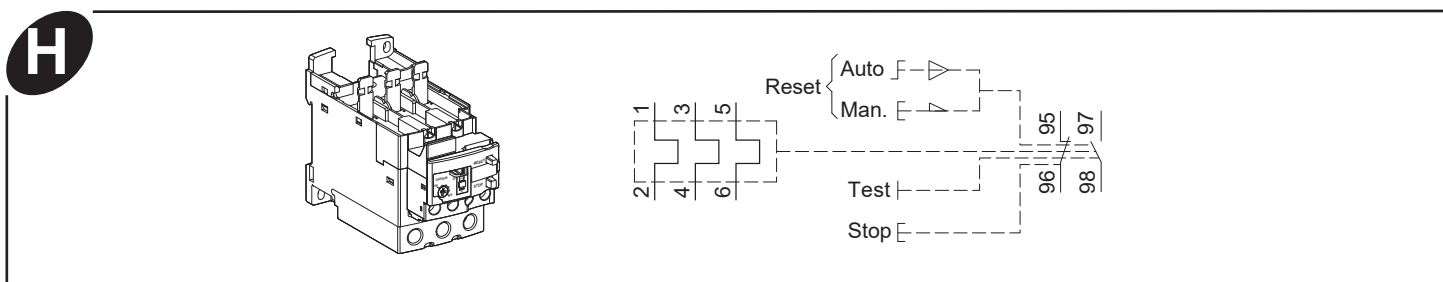
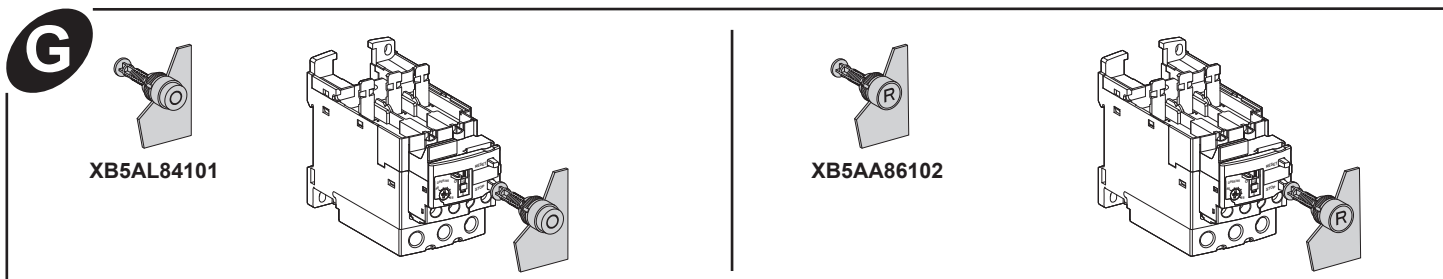
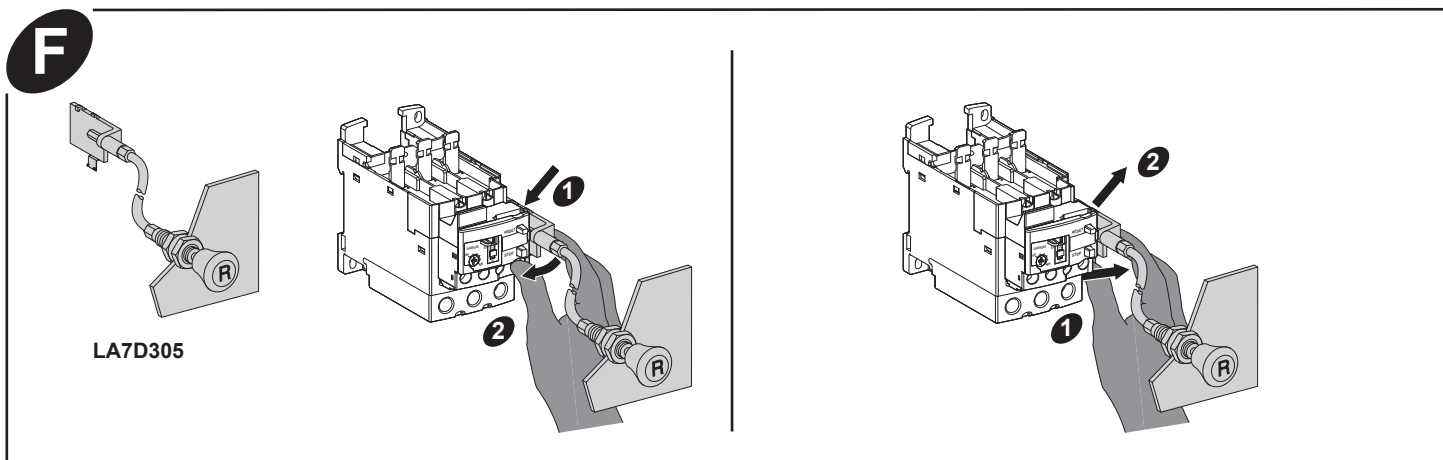
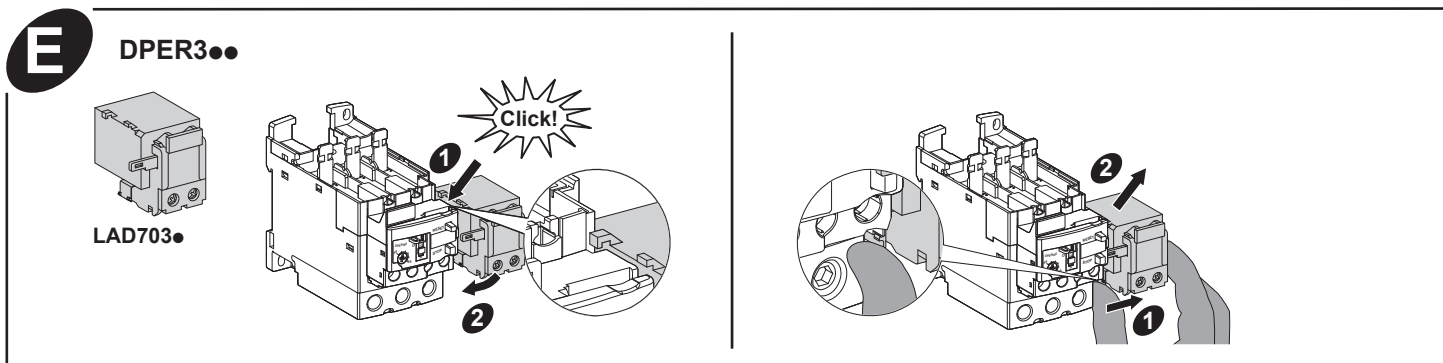
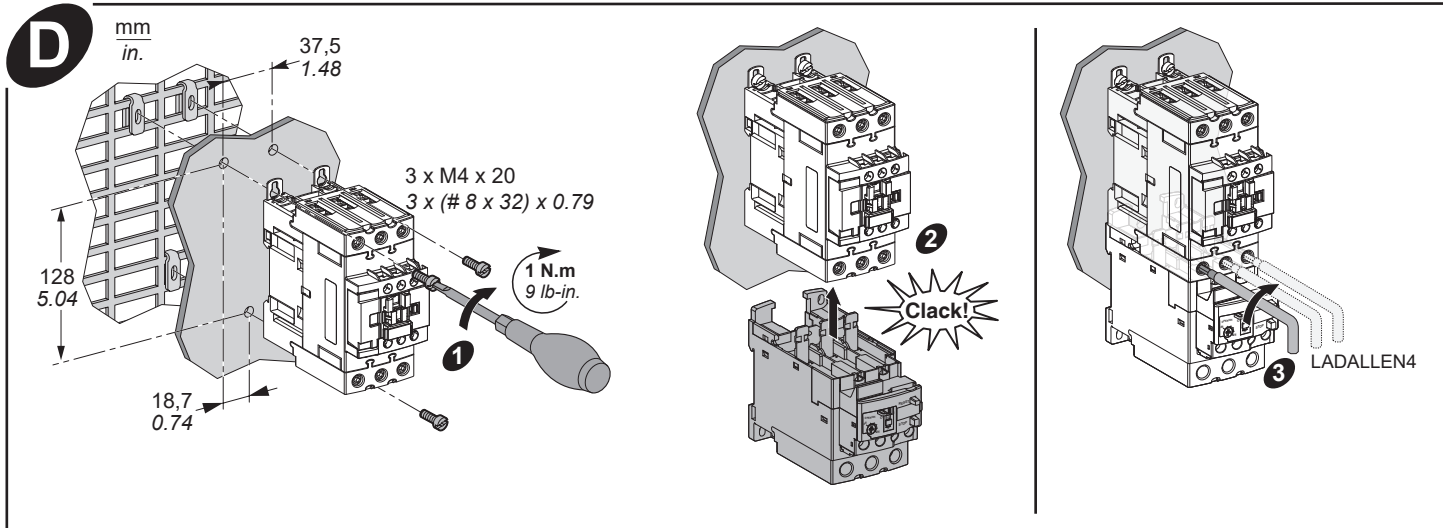

I

⚠️ ⚠️ WARNING / AVERTISSEMENT

HAZARD OF FIRE OR ELECTRIC SHOCK
The wires must not be inserted outside of the cage.
Failure to follow these instructions can result in death, serious injury, or equipment damage.

RISQUE D'INCENDIE OU D'ÉLECTROCUTION
Les fils ne doivent pas être insérés à l'extérieur de la cage.
Si ces directives ne sont pas respectées, cela peut entraîner la mort ou des blessures graves ou des dommages matériels.

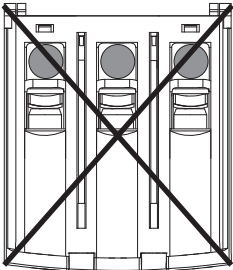
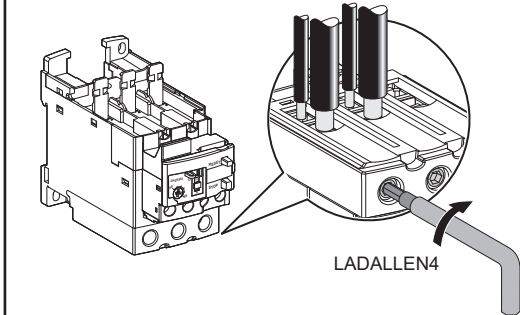
DPER3●●						
	16 mm	2.5...16 mm²	2 x 2.5...16 mm²	2 x 2.5...10 mm²	5 N.m	
	16 mm	25 mm²	-	-	7 N.m	
	0.63 in.	AWG 14...6	2 x AWG 14...6	-	45 lb-in.	
	0.63 in.	AWG 4	-	-	62 lb-in.	4 mm 0.16 in.

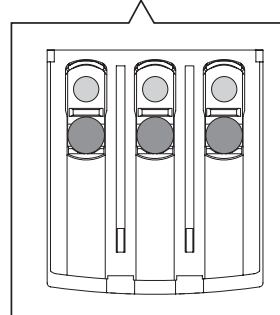

J

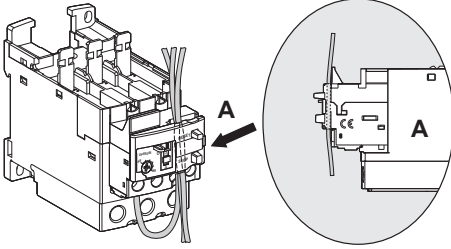

DPER3●●						
	10 mm	1...25 mm²	1...25 mm²	1...25 mm²	1,7 N.m	
	0.4 in.	AWG 18...14	AWG 18...14	AWG 18...14	15 lb-in.	

K

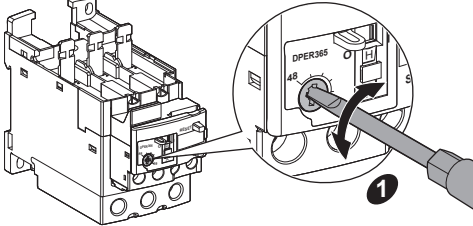

48 min. → In/FLA → 65 max.

L

Man. (for manual)	Man. (pour manuel)
Auto (for automatic)	Auto (matique)

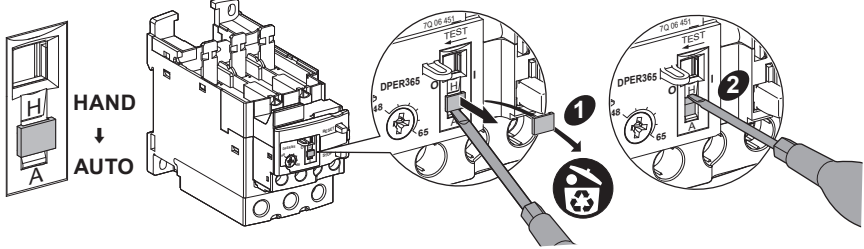

⚠️ ⚠️ WARNING / AVERTISSEMENT

AUTOMATIC START HAZARD

Motor connected to the circuit may start automatically in auto restart position.
Failure to follow these instructions can result in death, serious injury, or equipment damage.

RISQUE DE DÉMARRAGE AUTOMATIQUE

En mode de redémarrage automatique, il est possible que le moteur connecté au circuit démarre automatiquement.
Si ces directives ne sont pas respectées, cela peut entraîner la mort ou des blessures graves ou des dommages matériels.

