

# SPECIFICATIONS

---



## In This Chapter...

Bus Coupler: PX-MOD .....	2-2
Bus Coupler: PX-TCP1 .....	2-6
Bus Coupler: PX-TCP2 .....	2-10
Bus Coupler: PX-EIP1 .....	2-14
Protos X Terminal Types .....	2-18
Bus End/Expansion Terminals .....	2-20
Power Terminals .....	2-24
Analog Terminals .....	2-40

# Bus Coupler: PX-MOD



The PX-MOD Modbus RTU/ASCII Slave Bus Coupler allows connection of up to 64 terminals per assembly, 255 terminals total, in a Modbus RTU/ASCII serial network. The PX-MOD communicates using high-level Modbus commands and automatically assigns Modbus addresses for inputs and outputs. The maximum amount of data is 512 bytes of input data and 512 bytes of output data, with up to 1020 inputs, 1020 outputs, 256 analog inputs and 256 analog outputs, when using bus expansion.

The PX-MOD has one RS-485 D-sub 9-pin port that functions in half duplex for connection to a Modbus master. The maximum distance from master to the PX-MOD is 4000 feet (1200 meters) using 24 AWG shielded, twisted pair. Termination resistors are required at the beginning and end of the network. It is highly recommended that a dedicated network be used for the Protos X system. A minimal assembly consists of a PX-MOD Bus Coupler, I/O Terminals and a Bus End Terminal.

PX-MOD I/O Bus Specifications	
Supply Power for I/O Bus	24VDC (-15%/+20%)
Input Current from Power Supply	70mA + (total I/O bus current) / 4
Recommended Fuse	10A Max
I/O Bus Current Supply	1000mA Max
Number of Bus Terminals Supported	64 per assembly, 255 w/ I/O Bus Expansion (based on power budget)
Number of Discrete Inputs/Outputs	1020 Inputs and 1020 Outputs with 255 terminals
Number of Analog Inputs/Outputs	256 inputs and 256 outputs
Maximum Number of Data Bytes*	512 Input Bytes and 512 Output Bytes

\* Number of Terminals can not exceed 512 input bytes and 512 output bytes.

PX-MOD Modbus Port Specifications	
Number of Stations	99
Station Configuration	Rotary Switches
Protocol	Modbus RTU/ASCII (default = RTU)
Data Transfer Rates	150, 300, 600, 1200, 2400, 4800, 9600, 19200, 38400 baud
Maximum Cable Length	4000 ft. (1,200m)
Connector Type	9-pin, D-Sub, RS-485
Recommended Cable	24AWG, Shielded, Twisted Pair

PX-MOD Terminal Power Bus Specifications	
Supply Power for Terminal Bus	24 VAC/VDC
Maximum Current	10A
Number of Power Contacts	2 (+24 VAC/DC, 0V)

**IMPORTANT!**



### Hot-Swapping Information

**Note:** This device cannot be Hot Swapped.

General Specifications	
Operating Temperature	32° to 131°F (0° to 55 °C)
Storage Temperature	-13° to 185°F (-25° to 85 °C)
Relative Humidity	5% to 95%, non-condensing
Environment Air	No corrosive gases permitted
Mounting/Orientation Restrictions	35mm DIN rail/None
Vibration	Conforms to EN 60068-2-6
Shock	Conforms to EN 60068-2-27
Noise Immunity	Conforms to EN 61000-6-2
Protection Class	IP20
Weight	100g (3.5 oz)
Dimensions (WxHxD)	44mm x 100mm x 66.4 mm (1.73 in x 3.94 in x 2.61 in)
Agency Approvals*	UL/cUL File No. E157382, CE

\* To obtain the most current agency approval information, see the Agency Approval Checklist section on the specific part number's web page.

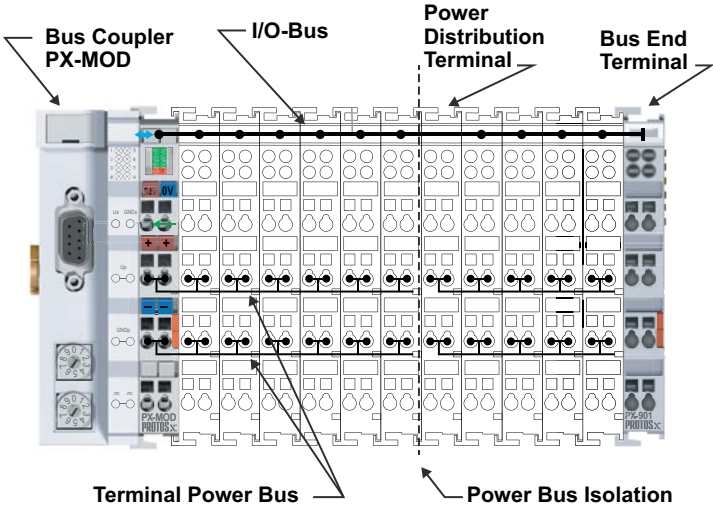
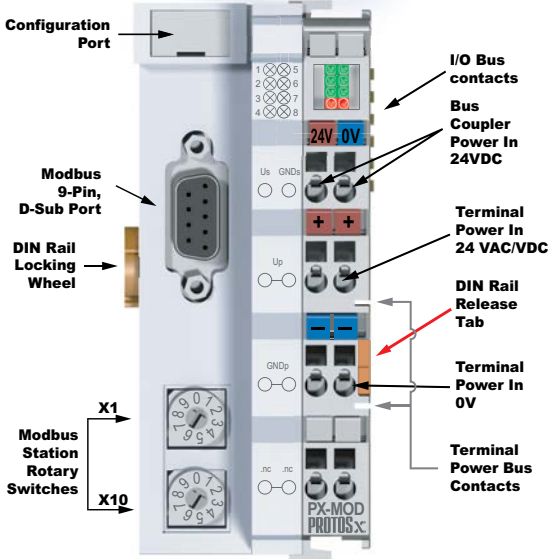

- It is important to stay within the following three specifications:
1. Do not exceed the total number of 64 Terminals allowed per Assembly.
  2. Do not exceed the total number of 512 Input Bytes and 512 Output Bytes.
  3. Do not exceed the Coupler I/O Bus Power Budget of 1000mA as there is no internal current protection.

## Chapter 2: Specifications

### Configuration Port

The Service Port connector is located under the flip-cover shown. This port is used for communication with the software configuration tool. The software configuration tool auto-configures the Modbus addresses and the interface allows the user to:

- Run the configurator
- View the configured Modbus addresses
- Modify the baud rate
- Change the Modbus offset
- Reboot the coupler
- Disable or modify Watchdog timer



Requires cable PX-USB-232, with a USB type A connector for the PC and a 4-pin custom micro connector for the Bus Coupler. Works with PX-CFGSW configuration software.

*\*Some 485 devices connected to the D-sub 9-pin may prevent Comm to the Configuration Port.*

### Status LEDs

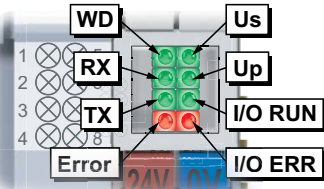

### LED Descriptions

LED	Status: ON	Status: OFF
Green LED 1: WD	Watchdog is active	Watchdog error
Green LED 2: RX	Data being received	No data being received
Green LED 3: TX	Data being transmitted	No data being transmitted
Red LED 4: ERROR	Data Error, communications with the master device has been lost.	No data error or checksum error
Green LED 5: Us	Bus Coupler power on	Bus Coupler power off
Green LED 6: Up	Terminal power on	Terminal power off
Green LED 7: I/O RUN	I/O bus data active	Watchdog-timer overflow
Red LED 8: I/O ERR	I/O bus error, blinking code.	No I/O bus error

### D-sub 9-pin, RS485 Connector

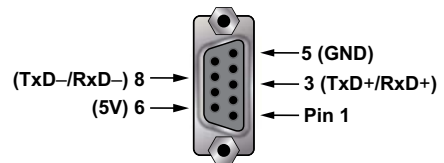

### Address Selection - Rotary Switches

The Modbus node address for the PX-MOD is set using both rotary switches on the front of the coupler. The address is configured within the 01 to 99 range. The configured value of 00 is reserved for programming and configuration.

The lower rotary switch is used to set the tens digit (x10) of the node address. The upper rotary switch is used to set the ones digit (x1) of the node address. The switch address is accepted only when power is cycled. The example shown is configured for a node address of 21.

# PX-MOD Wiring Connections

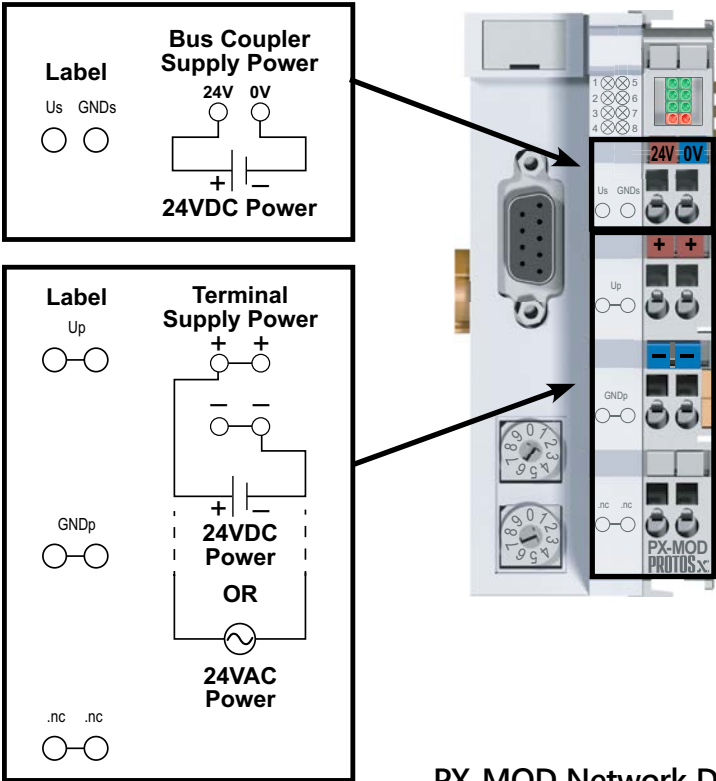

## PX-MOD Network Diagram

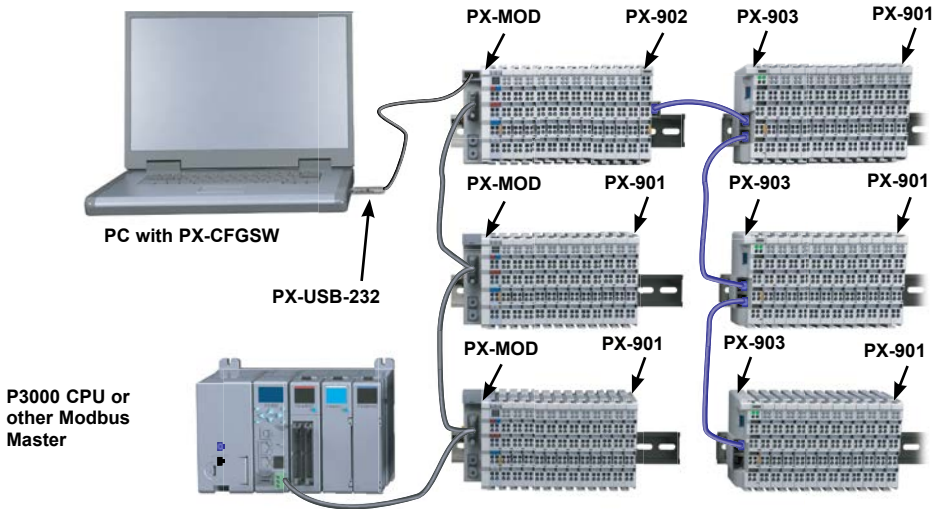

# Bus Coupler: PX-TCP1



The PX-TCP1 Modbus TCP Server Bus Coupler allows connection of up to 64 terminals per assembly, 255 terminals total, in a Modbus TCP network. The PX-TCP1 communicates using high-level Modbus commands and automatically assigns Modbus addresses for inputs and outputs. The maximum amount of data is 512 bytes of input data and 512 bytes of output data, with up to 1020 inputs, 1020 outputs, and 128 analog inputs or outputs, when using bus expansion.

The PX-TCP1 has one RJ45 Ethernet 10/100 Base T port for connection to a Modbus client. The maximum distance from client to the PX-TCP1 is 330 feet (100 meters) using 24AWG shielded, twisted pair Cat5e cable. It is highly recommended that a dedicated network be used for the Protos X system. A minimal assembly consists of a PX-TCP1 Bus Coupler, I/O Terminals and a Bus End Terminal.

PX-TCP1 I/O Bus Specifications	
Supply Power for I/O Bus	24VDC (-15%/+20%)
Input Current from Power Supply	70mA + (total I/O bus current) / 4
Recommended Fuse	10A Max
I/O Bus Current Supply	1000mA Max
Number of Bus Terminals Supported	64 per assembly, 255 w/ I/O Bus Expansion (based on power budget)
Number of Discrete Inputs/Outputs	1020 Inputs and 1020 Outputs with 255 terminals
Number of Analog Inputs/Outputs	128 total
Maximum Number of Data Bytes*	512 Input Bytes and 512 Output Bytes

\* Number of Terminals can not exceed 512 input bytes and 512 output bytes.

PX-TCP1 Modbus Port Specifications	
Configuration	DIP switches and PX-CFGSW software
Protocol	Modbus TCP
Data Transfer Rates	10/100 Mbaud
Maximum Cable Length	100m between coupler and switch
Connector Type	Ethernet, RJ45
Recommended Cable	Shielded, Twisted Pair, Cat5e

PX-TCP1 Terminal Power Bus Specifications	
Supply Power for Terminal Bus	24 VAC/VDC
Maximum Current	10A
Number of Power Contacts	3 (+24 VAC/VDC, 0V, PE)

**IMPORTANT!**



### Hot-Swapping Information

**Note: This device cannot be Hot Swapped.**

General Specifications	
Operating Temperature	32° to 131°F (0° to 55 °C)
Storage Temperature	-13° to 185°F (-25° to 85 °C)
Relative Humidity	5% to 95%, non-condensing
Environment Air	No corrosive gases permitted
Mounting/Orientation Restrictions	35mm DIN rail/None
Vibration	Conforms to EN 60068-2-6
Shock	Conforms to EN 60068-2-27
Noise Immunity	Conforms to EN 61000-6-2
Protection Class	IP20
Weight	100g (3.5 oz)
Dimensions (WxHxD)	44mm x 100mm x 66.4 mm (1.73 in x 3.94 in x 2.61 in)
Agency Approvals*	UL/cUL File No. E157382, CE

\* To obtain the most current agency approval information, see the Agency Approval Checklist section on the specific part number's web page.

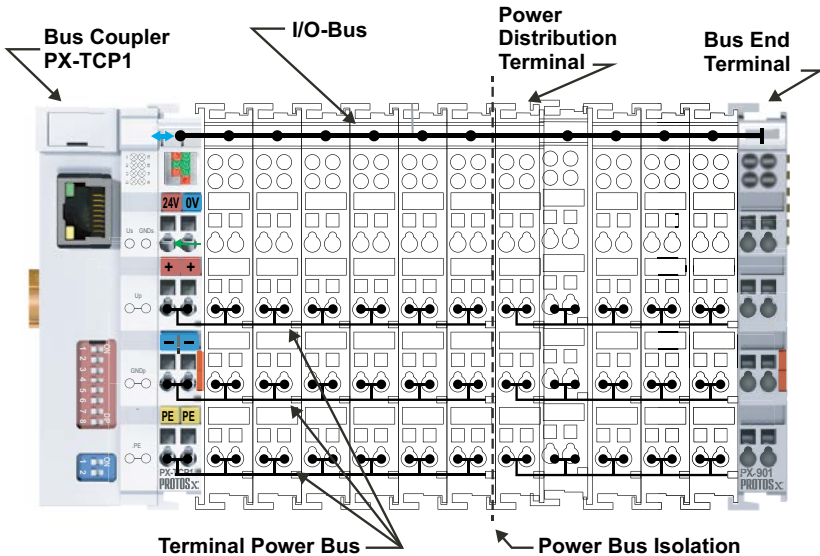
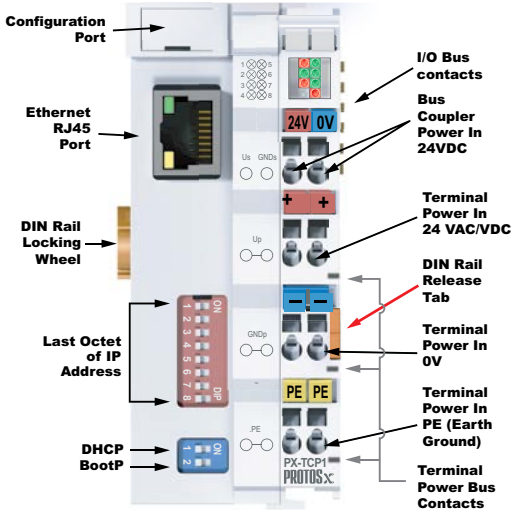

It is important to stay within the following three specifications:

1. Do not exceed the total number of 64 Terminals allowed per Assembly.
2. Do not exceed the total number of 512 Input Bytes and 512 Output Bytes.
3. Do not exceed the Coupler I/O Bus Power Budget of 1000mA as there is no internal current protection.

# Chapter 2: Specifications

## Configuration Port



The Service Port connector is located under the flip-cover shown. This port is used for communication with the software configuration tool. The software configuration tool autoconfigures the Modbus addresses and the interface allows the user to:

- Run the configurator
- View the configured Modbus addresses
- Modify the baud rate
- Reboot the coupler
- Change the Modbus offset
- Configure first three octets of the IP address
- Disable or modify Watchdog timer

Requires cable PX-USB-232, with a USB type A connector for the PC and a 4-pin custom micro connector for the Bus Coupler. Works with PX-CFGSW configuration software.

## Status LEDs

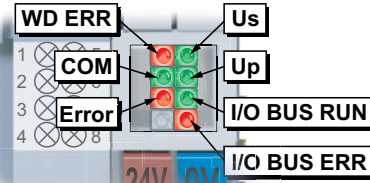

## LED Descriptions

LED	Status: ON	Status: OFF
Red LED 1: WD ERR	Watchdog error	Watchdog is active after first Modbus write
Green LED 2: COM	Ethernet data is active (On or Flashing)	No data being received
Red LED 3: ERROR	Flashing: waiting for IP address if set to DHCP or BootP.	No error
Green LED 4: RTE	Not used	
Green LED 5: Us	Bus Coupler power on	Bus Coupler power off
Green LED 6: Up	Terminal power on	Terminal power off
Green LED 7: I/O-Bus RUN	I/O bus data active (On or Flashing)	No I/O bus activity
Red LED 8: I/O-Bus ERR	I/O bus error, blinking code.	No I/O bus error

## RJ45 Connector

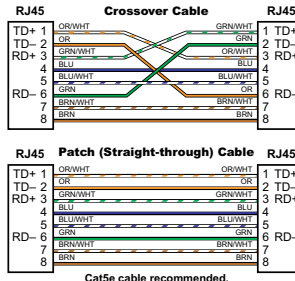
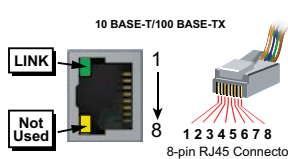

## Address Selection DIP Switches

The last octet or byte of the IP Address for the PX-TCP1 is set using the large bank of DIP switches on the front of the coupler. The smaller bank of DIP switches is used to select the type of address assignment (DHCP, BootP, firm setting).

The IP Address DIP switches are arranged so that switch 1 corresponds to bit 0 (LSB) and switch 8 to bit 7 (MSB). The base address used is configured using the PX-CFGSW software tool. With the original factory settings, the IP Address is configured to the value 0.0.0.0 by default.



# PX-TCP1 Wiring Connections

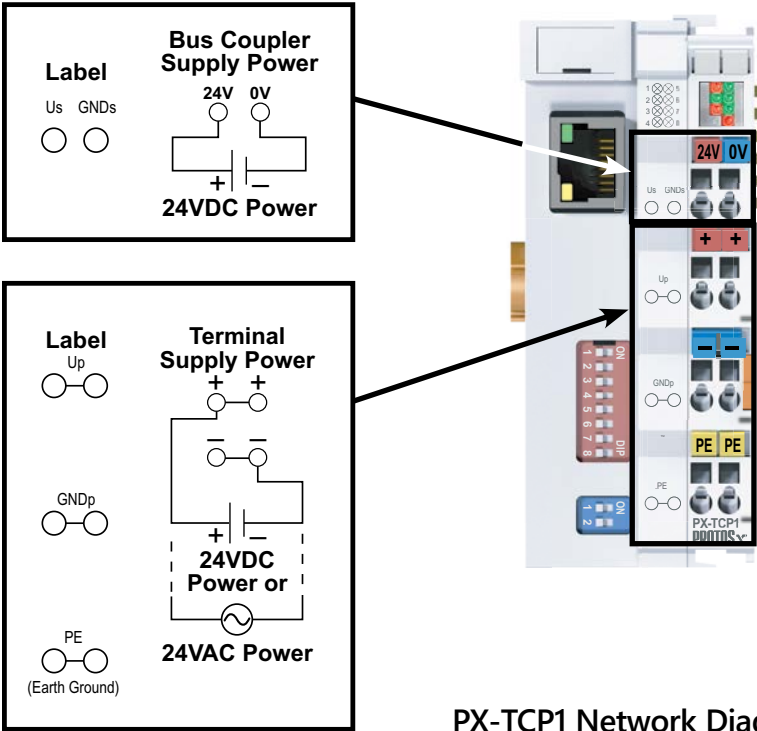

## PX-TCP1 Network Diagram

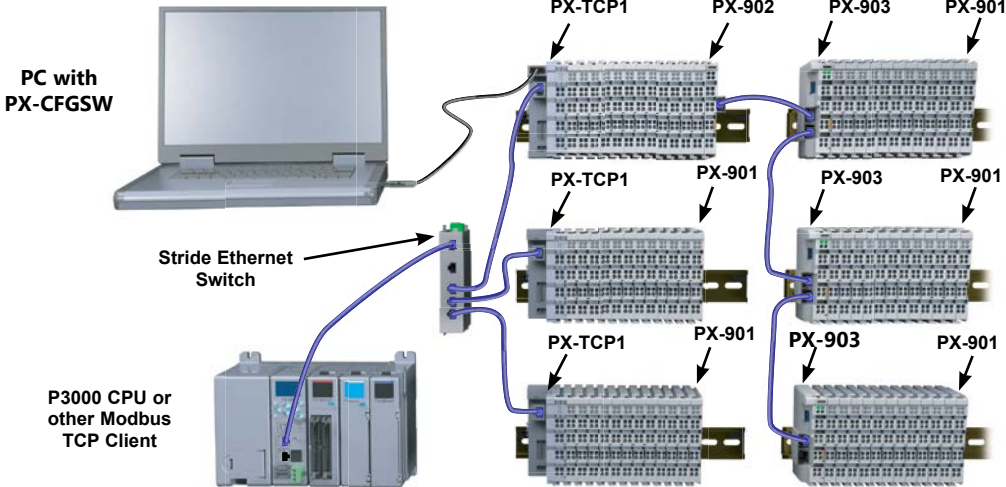

# Bus Coupler: PX-TCP2



The PX-TCP2 Modbus TCP Server Bus Coupler allows connection of up to 64 terminals in a Modbus TCP network. The PX-TCP2 communicates using high-level Modbus commands and automatically assigns Modbus addresses for inputs and outputs. The maximum amount of data is 512 bytes of input data and 512 bytes of output data, with up to 512 inputs, 512 outputs, and 128 analog inputs or outputs.

Communication to the client is via an RJ45 Ethernet port. A second port allows expansion of up to 20 total PX-TCP2 Couplers in a network. The maximum distance from a client to a PX-TCP2, and between each additional PX-TCP2, is 330 feet (100 meters) for each segment, using 24 AWG shielded, twisted pair Cat5e cable. It is highly recommended that a dedicated network be used for the Protos X system. A minimal assembly consists of a PX-TCP2 Bus Coupler, I/O Terminals and a Bus End Terminal.

PX-TCP2 I/O Bus Specifications	
Supply Power for I/O Bus	24VDC (-15%/+20%)
Input Current from Power Supply	70mA + (total I/O bus current) / 4
Recommended Fuse	10A Max
I/O Bus Current Supply	1750mA Max
Number of Bus Terminals Supported	64 per assembly (based on power budget)
Number of Discrete Inputs/Outputs	512 Inputs and 512 Outputs
Number of Analog Inputs/Outputs	128 total
Maximum Number of Data Bytes*	512 Input Bytes and 512 Output Bytes

\* Number of Terminals can not exceed 512 input bytes and 512 output bytes.

PX-TCP2 Modbus Port Specifications	
Configuration	DIP switches and PX-CFGSW software
Protocol	Modbus TCP
Data Transfer Rates	10/100 Mbaud
Maximum Cable Length	100m between Client and Coupler to Coupler
Connector Type	Ethernet, 2 x RJ45 (2 Channel Switch)
Recommended Cable	Shielded, Twisted Pair, Cat5e

PX-TCP2 Terminal Power Bus Specifications	
Supply Power for Terminal Bus	24 VAC/VDC
Maximum Current	10A
Number of Power Contacts	3 (+24 VAC/VDC, 0V, PE)

**IMPORTANT!**



### Hot-Swapping Information

**Note:** This device cannot be Hot Swapped.

General Specifications	
Operating Temperature	32° to 131°F (0° to 55 °C)
Storage Temperature	-13° to 185°F (-25° to 85 °C)
Relative Humidity	5% to 95%, non-condensing
Environment Air	No corrosive gases permitted
Mounting/Orientation Restrictions	35mm DIN rail/None
Vibration	Conforms to EN 60068-2-6
Shock	Conforms to EN 60068-2-27
Noise Immunity	Conforms to EN 61000-6-2
Protection Class	IP20
Weight	170g (6.0 oz)
Dimensions (WxHxD)	44mm x 100mm x 66.4 mm (1.73 in x 3.94 in x 2.61 in)
Agency Approvals*	UL/cUL File No. E157382, CE

\* To obtain the most current agency approval information, see the Agency Approval Checklist section on the specific part number's web page.

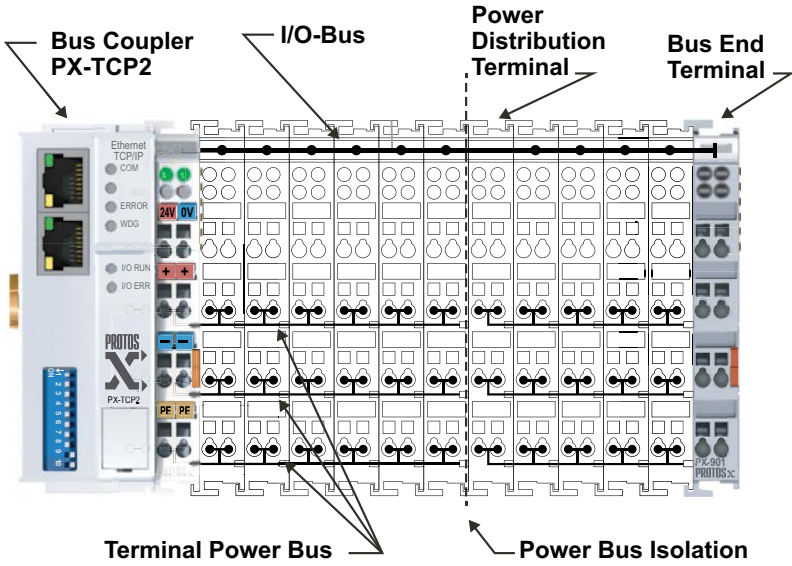
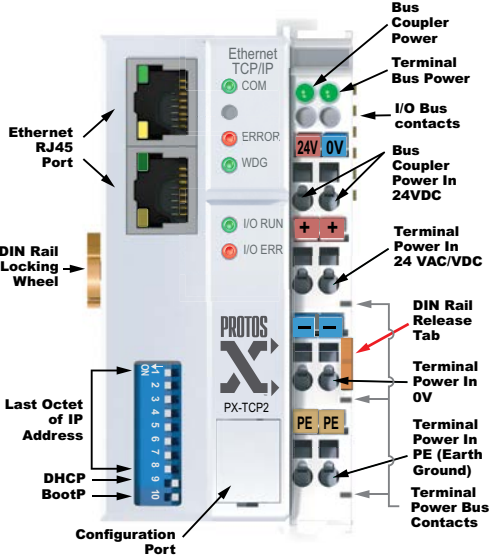

- It is important to stay within the following three specifications:
1. Do not exceed the total number of 64 Terminals allowed per Assembly.
  2. Do not exceed the total number of 512 Input Bytes and 512 Output Bytes.
  3. Do not exceed the Coupler I/O Bus Power Budget of 1750mA as there is no internal current protection.

## Chapter 2: Specifications

### Configuration Port



The Service Port connector is located under the flip-cover shown. This port is used for communication with the software configuration tool. The software configuration tool autoconfigures the Modbus addresses and the interface allows the user to:

- Run the configurator
- View the configured Modbus addresses
- Modify the baud rate
- Reboot the coupler
- Change the Modbus offset
- Configure first three octets of the IP address
- Disable or modify Watchdog timer

Requires cable PX-USB-232, with a USB type A connector for the PC and a 4-pin custom micro connector for the Bus Coupler. Works with PX-CFGSW configuration software.

### Status LEDs



### LED Descriptions

LED	Status: ON	Status: OFF
Green Power LED (left): Bus Coupler	Bus Coupler power on	Bus Coupler power off
Green Power LED (right): Terminal Bus	Terminal Bus power on	Terminal Bus power off
Green Ethernet LED: COM	On/Flashing: Receiving Data	No data being received
Red Ethernet LED: ERROR	Flashing: waiting for IP address if set to DHCP or BootP.	No Error
Green Ethernet LED: WDG	Watchdog is active	Watchdog error
Green I/O Bus LED: I/O RUN	I/O Bus Data Active (On or Flashing)	Terminal power off
Red I/O Bus LED: I/O ERR	I/O bus error, blinking code.	No I/O bus error

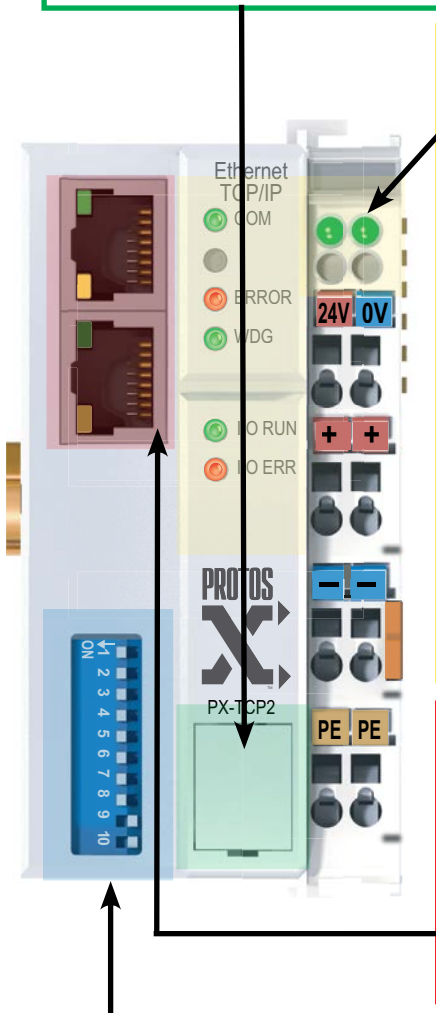

### RJ45 Connector

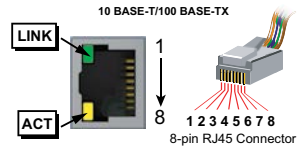

RJ45	Patch (Straight-through) Cable	RJ45
TD+ 1	ORWHT	ORWHT
TD- 2	GRN	GRN
RD+ 3	GRNWHT	GRNWHT
4	BLU	BLU
5	BLUWHT	BLUWHT
RD- 6	GRN	GRN
7	BRNWHT	BRNWHT
8	BRN	BRN

Cat5e cable recommended.

### Address Selection DIP Switches

The last octet or byte of the IP Address, as well as the type of address assignment (DHCP, BootP, firm setting), for the PX-TCP2 is set using the DIP switches on the front of the coupler. The IP Address DIP switches are arranged so that switch 1 corresponds to bit 0 (LSB) and switch 8 to bit 7 (MSB). Switches 9 and 10 allow for the address assignment selection. The base address used is configured using the PX-CFGSW software tool. With the original factory settings, the IP Address is configured to the value 0.0.0.0. by default.

# PX-TCP2 Wiring Connections

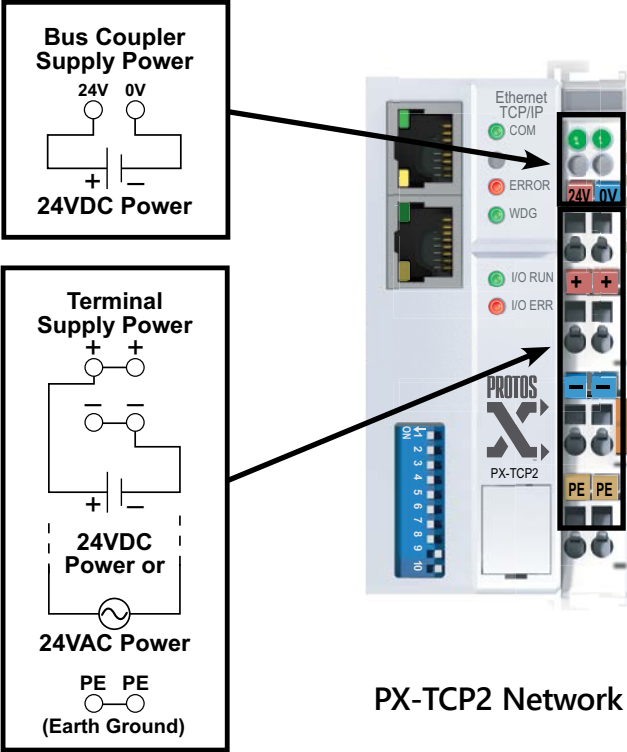

## PX-TCP2 Network Diagram

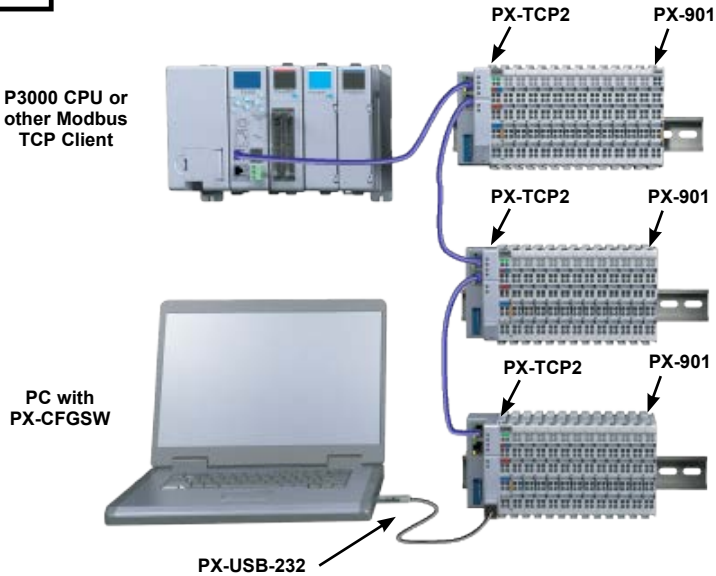

### Bus Coupler: PX-EIP1



The PX-EIP1 consists of one RJ45 Ethernet 10/100 Base T port for connection to an Ethernet client. The PX-EIP1 performs as a EtherNet/IP server in an EtherNet/IP network. Communication to the client is via an RJ45 Ethernet port. The maximum distance from client to the PX-EIP1 is 330 feet (100 meters) using 24AWG shielded, twisted pair Cat5e cable. The PX-EIP1 Bus Coupler supports up to 64 terminals per assembly, 255 terminals with Bus Expansion Couplers.

It is highly recommended that a dedicated network be used for the Protos X system. A minimal assembly consists of a PX-EIP1 Bus Coupler, I/O Terminals and a Bus End Terminal.

See page 2-59 for EtherNet/IP communication discussion.

**IMPORTANT!**



#### Hot-Swapping Information

**Note: This device cannot be Hot Swapped.**

#### PX-EIP1 I/O Bus Specifications

Supply Power for I/O Bus	24VDC (-15%/+20%)
Input Current from Power Supply	70mA + (total I/O bus current) / 4
Recommended Fuse	10A Max total
I/O Bus Current Supply	1000mA Max
Number of Bus Terminals Supported	64 per assembly, 255 w/ I/O Bus Expansion (based on power budget)
Number of Discrete Inputs/Outputs	1020 Inputs and 1020 Outputs with 255 terminals
Number of Analog Inputs/Outputs	128 total
Maximum Number of Data Bytes*	512 Input Bytes and 512 Output Bytes

\* Number of Terminals can not exceed 512 input bytes and 512 output bytes.

#### PX-EIP1 EtherNet/IP Port Specifications

Configuration	DIP switches and PX-CFGSW software (Requires V2.0 or later)
Protocol	EtherNet/IP (Support for Implicit Messaging only)
Scanner/Client Connections	1
Data Transfer Rates	10/100 Mbps (Auto-crossover)
Maximum Cable Length	100m between coupler and switch
Connector Type	Ethernet, RJ45
Recommended Cable	Shielded, twisted pair, Cat5e

#### PX-EIP1 Terminal Power Bus Specifications

Supply Power for Terminal Bus	24VDC
Maximum Current	10A
Number of Power Contacts	3 (+24 VAC/VDC, 0V, PE)

General Specifications	
Operating Temperature	32° to 131°F (0° to 55 °C)
Storage Temperature	-13° to 185°F (-25° to 85 °C)
Relative Humidity	5% to 95%, non-condensing
Environment Air	No corrosive gases permitted
Mounting/Orientation Restrictions	35mm DIN rail/None
Vibration	Conforms to EN 60068-2-6
Shock	Conforms to EN 60068-2-27
Noise Immunity	Conforms to EN 61000-6-2
Noise Emission	Conforms to EN 61000-6-4
Protection Class	IP20
Weight	100g (6.0 oz)
Dimensions (WxHxD)	44 x 100 x 66.4 mm (1.73 x 3.94 x 2.61 in)
Agency Approvals*	UL/cUL File No. E172151 (BK9055), CE

\* To obtain the most current agency approval information, see the Agency Approval Checklist section on the specific part number's web page.

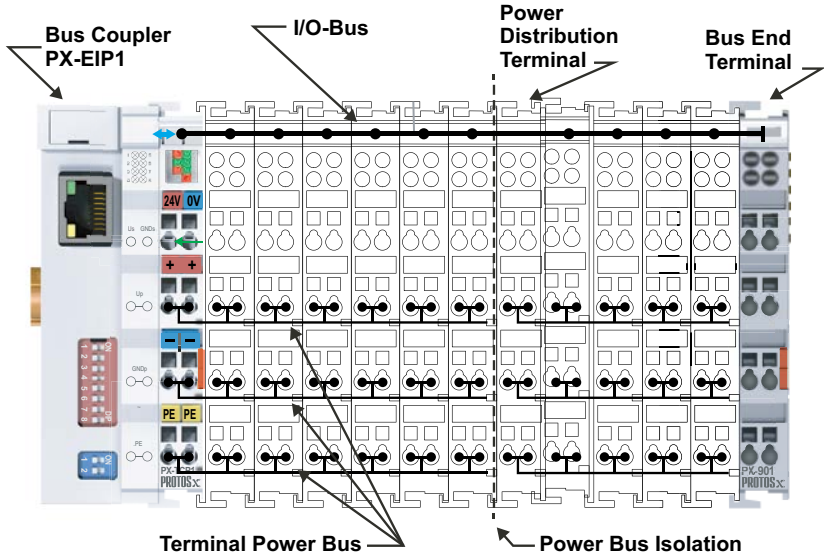
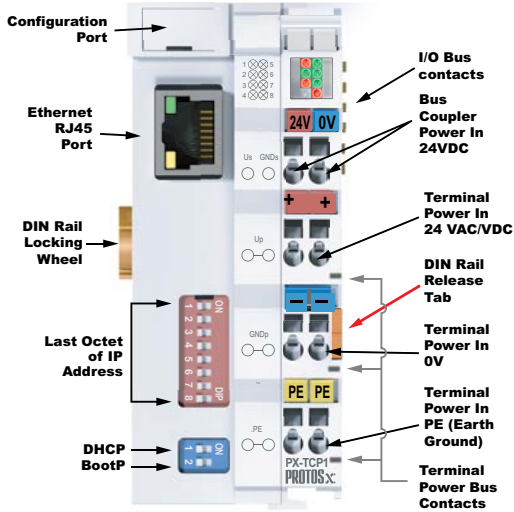

It is important to stay within the following three specifications:

1. Do not exceed the total number of 64 Terminals allowed per Assembly.
2. Do not exceed the total number of 512 Input Bytes and 512 Output Bytes.
3. Do not exceed the Coupler I/O Bus Power Budget of 1000mA as there is no internal current protection.

## Chapter 2: Specifications

**Configuration Port** The Configuration Port connector is located under the flip-cover shown below. This port is used for communication with the software configuration tool. The software configuration tool auto-configures the EtherNet/IP addresses and the interface allows the user to:



- Run the configurator
- View the configured EtherNet/IP bytes and words
- Reboot the coupler
- Configure first three octets of the IP address

Requires cable PX-USB-232, with a USB 2.0 type A connector for the PC and a 4-pin custom micro connector for the Bus Coupler. Works with PX-CFGSW configuration software version 2.0 or later releases.

### Status LEDs

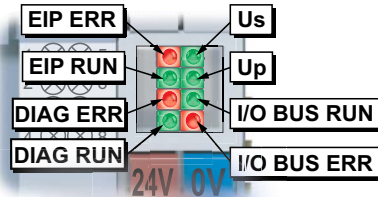

### LED Descriptions

LED	Status: ON	Status: OFF
Red LED 1: EIP ERR	See PX-CFGSW Help file or PX-US-ER-M manual Ch 5 for codes.	No EIP Error
Green LED 2: EIP Run	EIP Communication with Scanner (Client) Flashing: No active communication.	N/A
Red LED 3: DIAG Err	See PX-CFGSW Help File or PX-US-ER-M manual Ch 5 for codes.	No DIAG Err
Green LED 4: DIAG Run	Diagnostics active w/o error Flashing: Used in conjunction with Diag Error to determine fault.	N/A
Green LED 5: Us	Bus coupler power On	Bus coupler power Off
Green LED 6: Up	Terminal power On	Terminal power Off
Green LED 7: I/O Bus RUN	I/O bus data active (On or Flashing)	No I/O bus activity
Red LED 8: I/O Bus Err	I/O bus error, blinking code	No I/O bus error

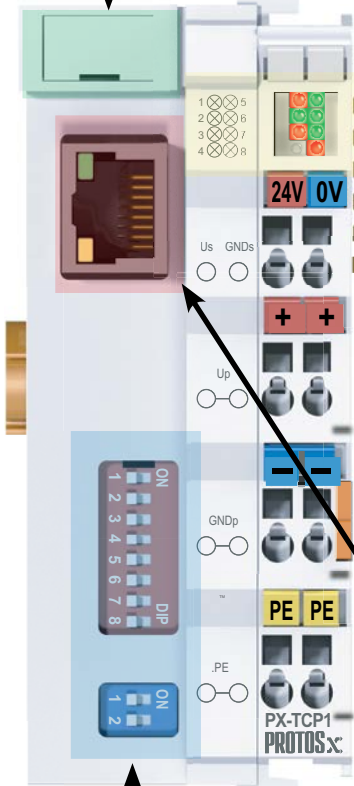

### RJ45 Connector

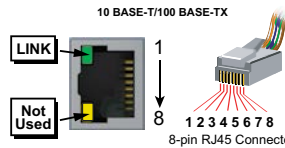

LED Status		
Green LINK LED	ON = Connection Good	Flashing = Comm Active

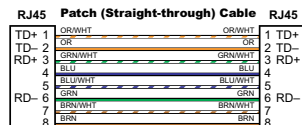
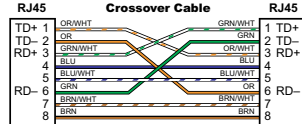

Cat5e cable recommended.

**Address Selection DIP Switches** The last octet or byte of the IP Address for the PX-EIP1 is set using the large bank of DIP switches on the front of the coupler. The smaller bank of DIP switches is used to select the type of address assignment (DHCP, BootP, firm setting).

The IP Address DIP switches are arranged so that switch 1 corresponds to bit 0 (LSB) and switch 8 to bit 7 (MSB). The base address used is configured using the PX-CFGSW software tool. With the original factory settings, the IP Address is configured to the value 0.0.0.0 by default.



PX-EIP1 Wiring Connections

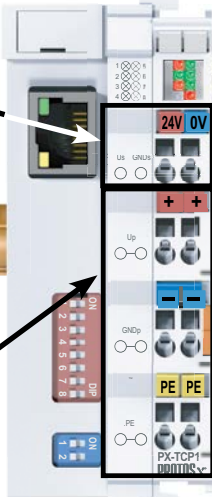
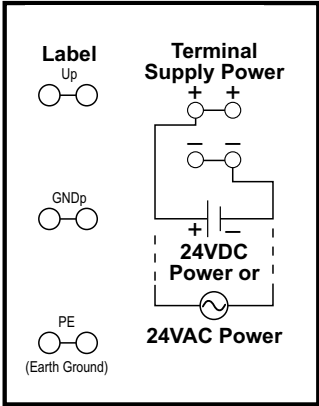
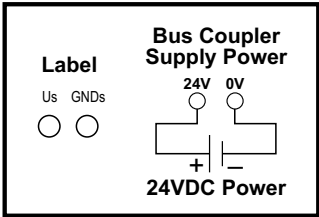

Wire connections are made through spring clamp style terminals. The terminals are designed for a single-conductor solid or stranded wire. Wire connection is made by firmly pushing the screwdriver into the screwdriver slot, inserting the wire into the wire slot and removing the screwdriver, locking the wire into position.

Wiring Specifications	
Connection Type	Spring Clamp Terminals
Wire Gauge /Wire Cross-Section	28–14 AWG / 0.08–2.5 mm <sup>2</sup>
Screwdriver Width	Use screwdriver width 2.5 mm (0.10) such as our TW-SD-MSL-2
Wire Stripping Length	8mm (5/16 in)

PX-EIP1 Network Diagram

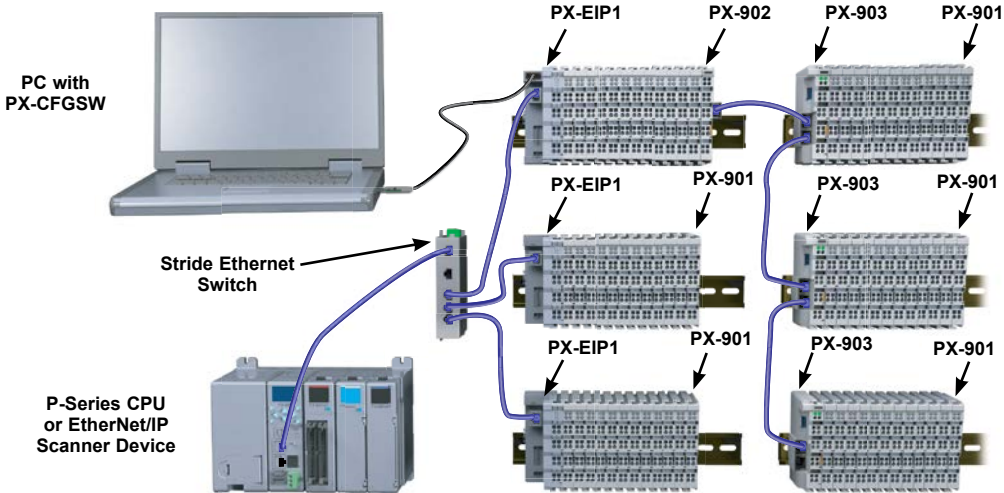

## Protos X Terminal Types

Another consideration when choosing terminals is the different types available. Some of the terminals will pass terminal bus power and terminal PE (earth ground) connections. Some terminals will only pass terminal bus power and others do not pass any terminal power. The modules that pass terminal power cannot be inserted to the right of a terminal that does not. For this reason it is important to note the differences in the terminal types and how they handle the terminal power bus. The terminal types are shown in the panels below and on the following page with a brief functional description.

Panel continued on following page.

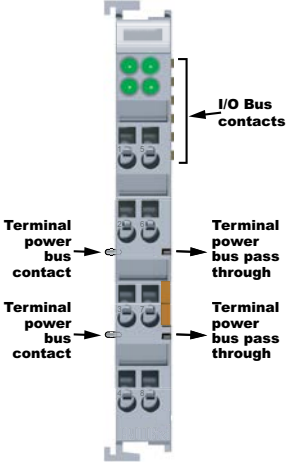
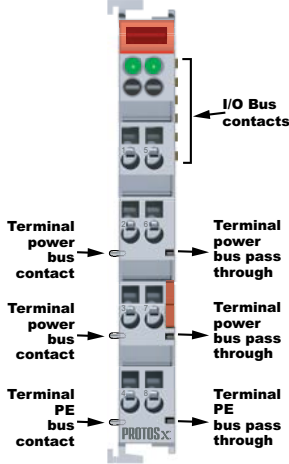
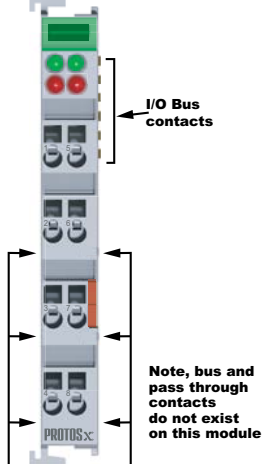
TYPE 1	TYPE 2	TYPE 3
		
<p>Type 1: This terminal passes the terminal power bus from the preceding terminal to the next terminal and therefore it must be mounted to a preceding terminal that passes bus power.</p>	<p>Type 2: This terminal passes the terminal power bus and PE from the preceding terminal to the next terminal and therefore it must be preceded by a terminal that passes both terminal power bus and PE.</p>	<p>Type 3: This terminal does not pass the terminal power bus or PE and can be preceded by any terminal, however it will interrupt the terminal power bus and PE.</p>

# Protos X Terminal Types, continued

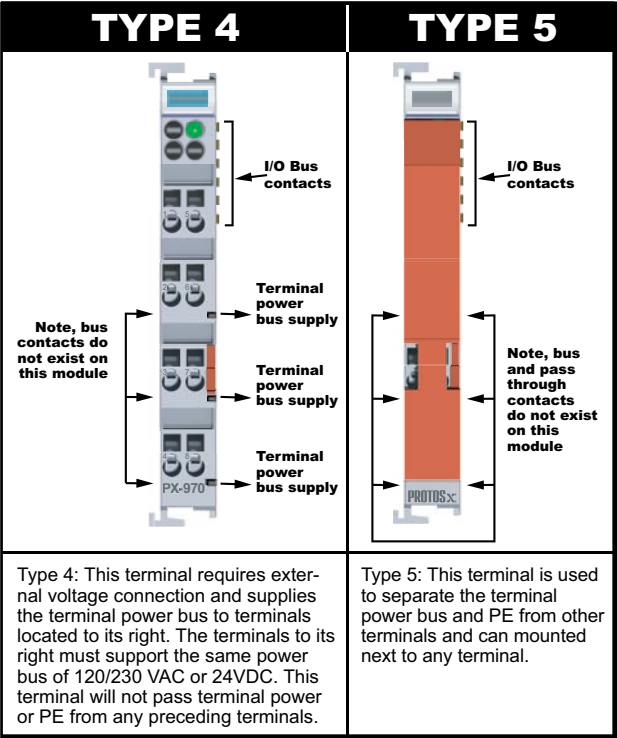

## Bus End/Expansion Terminals



### PX-901:

#### Bus End Terminal

The PX-901 (type 3) Bus End Terminal is installed at the end of a terminal assembly and is required for proper I/O Bus communication.

#### PX-901 Terminal Specifications

Current Consumption (from I/O Bus)	None
Electrical Isolation	500Vms (I/O bus/signal voltage)

PX-901 General Specifications	
Operating Temp	32 to 131 °F (0 to 55 °C)
Storage Temp	-13 to 185 °F (-25 to 85 °C)
Relative Humidity	5% to 95%, non-condensing
Environment Air	No corrosive gases permitted
Mounting/Orientation Restrictions	35mm DIN rail/None
Vibration	Conforms to EN 60068-2-6
Shock	Conforms to EN 60068-2-27/ EN 60068-2-29
Noise Immunity	Conforms to EN 61000-6-2/ EN 61000-6-4
Protection Class	IP20
Dimensions (WxHxD)	12 x 100 x 68.8 mm (0.47 x 3.94 x 2.71 in)
Adjacent Mounting on Bus Terminals with Power Contact	Yes
Adjacent Mounting on Bus Terminals without Power Contact	Yes
Passes Terminal Bus Power	No
Passes PE Bus	No
Weight	50g (1.8 oz)
Agency Approvals*	UL/cUL File No. E157382, CE

\* To obtain the most current agency approval information, see the Agency Approval Checklist section on the specific part number's web page.



**PX-902:  
Bus Expansion End Terminal**

The PX-902 (type 3) Bus Expansion End Terminal enables expansion of terminal assemblies. The PX-902 is installed at the end of a coupler terminal block assembly and connects the I/O Bus to a PX-903 Bus Expansion Coupler Terminal via the RJ45 port. No configuration is required.

PX-902 Terminal Specifications	
Power Source	I/O Bus power (approx. 6V)
Current Consumption (from I/O Bus)	70mA
Electrical Isolation	500Vms (I/O bus/field potential)
Heat Dissipation	1W max
Status Indicators	None
Number of Expansion Coupler Terminals Supported	31 max. (Using PX-903)
Configuration	Automatic
Maximum Distance Between Each Expansion Coupler	16.5 ft (5m)
Connection Type	Ethernet, RJ45
Recommended Cable	Shielded, Twisted Pair, Cat5e
Placement	Used only with Bus Coupler, replaces a PX-901 End Terminal

PX-902 General Specifications	
Operating Temp	32 to 131 °F (0 to 55 °C)
Storage Temp	-13 to 185 °F (-25 to 85 °C)
Relative Humidity	5% to 95%, non-condensing
Environment Air	No corrosive gases permitted
Mounting/Orientation Restrictions	35mm DIN rail/None
Vibration	Conforms to EN 60068-2-6
Shock	Conforms to EN 60068-2-27
Noise Immunity	Conforms to EN 61000-6-2
Protection Class	IP20
Dimensions (WxHxD)	27.5 x 100 x 68.8 mm (1.08 x 3.94 x 2.71 in)
Adjacent Mounting on Bus Terminals with Power Contact	Yes
Adjacent Mounting on Bus Terminals without Power Contact	Yes
Passes Terminal Bus Power	No
Passes PE Bus	No
Weight	146g (5.1 oz)
Agency Approvals*	UL/cUL File No. E157382, CE

\* To obtain the most current agency approval information, see the Agency Approval Checklist section on the specific part number's web page.

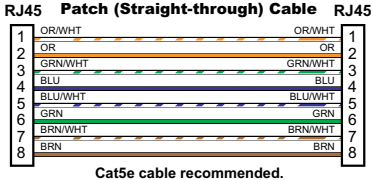
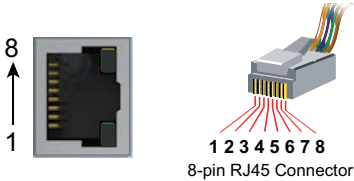



### PX-903:

#### Bus Expansion Coupler Terminal

The PX-903 (type 4) Bus Expansion Coupler Terminal enables expansion of terminal assemblies. The PX-903 is installed at the beginning of an expansion terminal assembly and connects to a PX-902 Bus Expansion End Terminal or other PX-903 terminals.

Use of the PX-902 and PX-903 allows expansion of up to 31 PX-903 couplers in a group. Communication is through the RJ45 ports. No configuration is required.

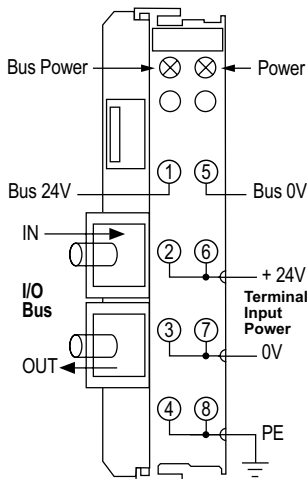

#### PX-903 General Specifications

Operating Temp	32 to 131 °F (0 to 55 °C)
Storage Temp	-13 to 185 °F (-25 to 85 °C)
Relative Humidity	5% to 95%, non-condensing
Environment Air	No corrosive gases permitted
Mounting/Orientation Restrictions	35mm DIN rail/None
Vibration	Conforms to EN 60068-2-6
Shock	Conforms to EN 60068-2-27
Noise Immunity	Conforms to EN 61000-6-2
Protection Class	IP20
Dimensions (WxHxD)	24.5 x 100 x 68.8 mm (0.96 x 3.94 x 2.71 in)
Adjacent Mounting on Bus Terminals with Power Contact	Yes (Supply)
Adjacent Mounting on Bus Terminals without Power Contact	Yes (Supply)
Passes Terminal Bus Power	Yes (Supply)
Passes PE Bus	Yes (Supply)
Weight	146g (5.1 oz)
Agency Approvals*	CE

\* To obtain the most current agency approval information, see the Agency Approval Checklist section on the specific part number's web page.

#### Bus Expansion Connection LED Status

LED	LED ON
Green I/O Bus In	I/O Bus is transferring data
Red I/O Bus In	I/O Bus fault

PX-903 Terminal Specifications	
Supply Power for I/O Bus	24VDC (-15%/+20%)
Current Consumption (from I/O Bus)	200mA Max, 70mA + (total I/O bus current) / 4
Recommended Fuse	10A max
I/O Bus Current Supply	400mA max
Starting Current	2.5 x continuous current
Number of Bus Terminals Supported	64
Supply for Terminal Power Bus	24 VAC/VDC
Maximum Terminal Power Bus Current	10A
Number of Terminal Power Bus Contacts	3 (+24 VAC/VDC, 0V, PE)
Electrical Isolation	500Vms (I/O bus/field potential)
Heat Dissipation	1W max
Status Indicators	2 Power LEDs
Number of Expansion Couplers in a Terminal Group	31 max
Configuration	Automatic
Maximum Distance Between Each Expansion Coupler	16.5 ft (5m)
Connection Type	Ethernet, 2 x RJ45
Recommended Cable	Shielded, Twisted Pair, Cat5e
Termination Resistor Switch	Dip Switch, set to Last for last coupler in expansion group, otherwise set to Next

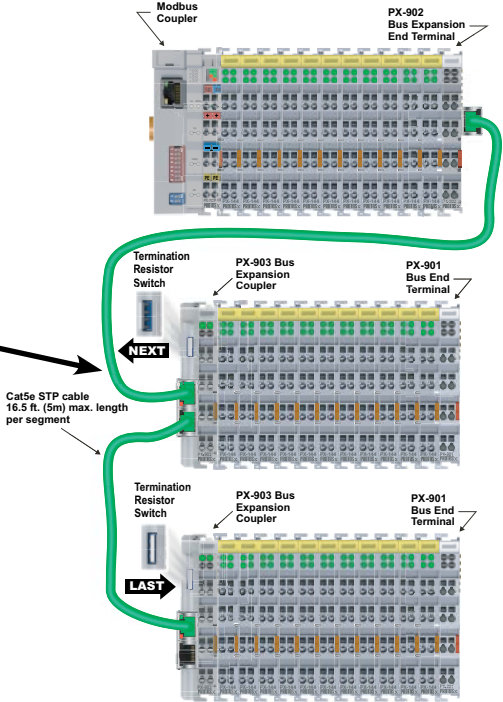
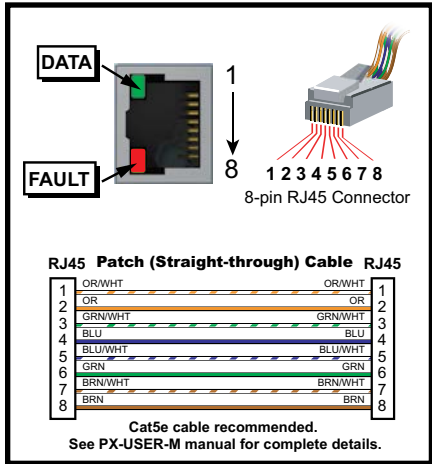

# Power Terminals



**PX-940:**  
**Power Feed Terminal, 24VDC**  
 The PX-940 (type 4) Power Feed Terminal allows adding or changing power voltage sources within a terminal assembly. Terminals mounted to the right of the PX-940 receive 24VDC through the terminal input connections.

PX-940 Terminal Specifications	
Supply Power to Terminal	24VDC
Maximum Current	10A
Number of Power Contacts	3 (+24VDC, 0V, PE)
Current Consumption (from I/O Bus)	None
Electrical Isolation	500Vms (I/O bus/signal voltage)
Heat Dissipation	1W max
Status Indicators	1 Power LED

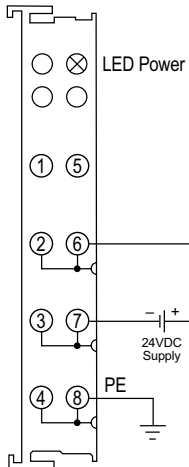

PX-940 General Specifications	
Operating Temp	32 to 131 °F (0 to 55 °C)
Storage Temp	-13 to 185 °F (-25 to 85 °C)
Relative Humidity	5% to 95%, non-condensing
Environment Air	No corrosive gases permitted
Mounting/Orientation Restrictions	35mm DIN rail/None
Vibration	Conforms to EN 60068-2-6
Shock	Conforms to EN 60068-2-27/ EN 60068-2-29
Noise Immunity	Conforms to EN 61000-6-2/ EN 61000-6-4
Protection Class	IP20
Dimensions (WxHxD)	12 x 100 x 68.8 mm (0.47 x 3.94 x 2.71 in)
Adjacent Mounting on Bus Terminals with Power Contact	Yes
Adjacent Mounting on Bus Terminals without Power Contact	Yes
Passes Terminal Bus Power	Yes (Supply)
Passes PE Bus	Yes (Supply)
Weight	50g (1.8 oz)
Agency Approvals*	UL/cUL File No. E157382, CE

\* To obtain the most current agency approval information, see the Agency Approval Checklist section on the specific part number's web page.





### PX-970: Power Feed Terminal, 120-230 VAC

The PX-970 (type 4) Power Feed Terminal allows adding or changing power voltage sources within a terminal assembly. Terminals mounted to the right of the PX-970 receive 120-230 VAC through the terminal input connections.

PX-970 Terminal Specifications	
Supply Power to Terminal	120-230 VAC
Maximum Current	10A
Number of Power Contacts	3 (120-230 VAC, 0V, PE)
Current Consumption (from I/O Bus)	None
Electrical Isolation	500Vms (I/O bus/signal voltage)
Heat Dissipation	1W max
Status Indicators	1 Power LED

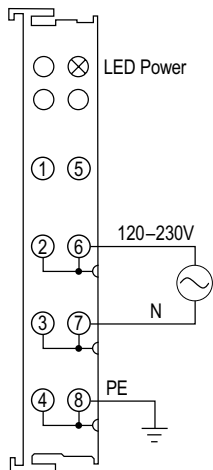

PX-970 General Specifications	
Operating Temp	32 to 131 °F (0 to 55 °C)
Storage Temp	-13 to 185 °F (-25 to 85 °C)
Relative Humidity	5% to 95%, non-condensing
Environment Air	No corrosive gases permitted
Mounting/Orientation Restrictions	35mm DIN rail/None
Vibration	Conforms to EN 60068-2-6
Shock	Conforms to EN 60068-2-27/ EN 60068-2-29
Noise Immunity	Conforms to EN 61000-6-2/ EN 61000-6-4
Protection Class	IP20
Dimensions (WxHxD)	12x 100 x 68.8 mm (0.47 x 3.94 x 2.71 in)
Adjacent Mounting on Bus Terminals with Power Contact	Yes
Adjacent Mounting on Bus Terminals without Power Contact	Yes
Passes Terminal Bus Power	Yes (Supply)
Passes PE Bus	Yes (Supply)
Weight	50g (1.8 oz)
Agency Approvals*	UL/cUL File No. E157382, CE

\* To obtain the most current agency approval information, see the Agency Approval Checklist section on the specific part number's web page.



### PX-949: Power Distribution Terminal, 24VDC

The PX-949 (type 1) Power Distribution Terminal provides eight 24VDC and eight 0V connections powered by the terminal power bus.

PX-949 Terminal Specifications	
Nominal Voltage	≤ 60VDC
Maximum Current	10A
Number of Power Contacts	(8) 24V and (8) 0V
Connection Voltage	24VDC
Current Consumption (from I/O Bus)	None
Electrical Isolation	500Vms (I/O bus/signal voltage)
Heat Dissipation	1W max

PX-949 General Specifications	
Operating Temp	32 to 131 °F (0 to 55 °C)
Storage Temp	-13 to 185 °F (-25 to 85 °C)
Relative Humidity	5% to 95%, non-condensing
Environment Air	No corrosive gases permitted
Mounting/Orientation Restrictions	35mm DIN rail/None
Vibration	Conforms to EN 60068-2-6
Shock	Conforms to EN 60068-2-27/ EN 60068-2-29
Noise Immunity	Conforms to EN 61000-6-2/ EN 61000-6-4
Protection Class	IP20
Dimensions (WxHxD)	12 x 100 x 68.8 mm (0.47 x 3.94 x 2.71 in)
Adjacent Mounting on Bus Terminals with Power Contact	Yes
Adjacent Mounting on Bus Terminals without Power Contact	No
Passes Terminal Bus Power	Yes
Passes PE Bus	No
Weight	60g (2.1 oz)
Agency Approvals*	UL/cUL File No. E157382, CE

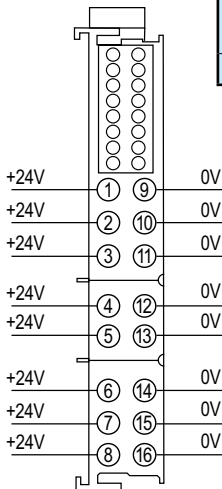

\* To obtain the most current agency approval information, see the Agency Approval Checklist section on the specific part number's web page.



**PX-908:  
Power Separation Terminal**

The PX-908 (type 5) Power Separation Terminal provides interruption of power along the terminal power bus while passing I/O bus data. It is easily identified by the orange cover.

PX-908 General Specifications	
Operating Temp	32 to 131 °F (0 to 55 °C)
Storage Temp	-13 to 185 °F (-25 to 85 °C)
Relative Humidity	5% to 95%, non-condensing
Environment Air	No corrosive gases permitted
Mounting/Orientation Restrictions	35mm DIN rail/None
Vibration	Conforms to EN 60068-2-6
Shock	Conforms to EN 60068-2-27/ EN 60068-2-29
Noise Immunity	Conforms to EN 61000-6-2/ EN 61000-6-4
Protection Class	IP20
Dimensions (WxHxD)	12 x 100 x 68.8 mm (0.47 x 3.94 x 2.71 in)
Adjacent Mounting on Bus Terminals with Power Contact	Yes
Adjacent Mounting on Bus Terminals without Power Contact	Yes
Passes Terminal Bus Power	No
Passes PE Bus	No
Weight	50g (1.8 oz)
Agency Approvals*	UL/cUL File No. E157382, CE

\* To obtain the most current agency approval information, see the Agency Approval Checklist section on the specific part number's web page.

## Chapter 2: Specifications

### Discrete Terminals

#### PX-144:

### Four-point, 24VDC Discrete Input Terminal

The PX-144 (type 1) DC Input Terminal provides four electrically isolated 24VDC sinking inputs with LED status. Intended for use with 3-wire and 2-wire sensors.

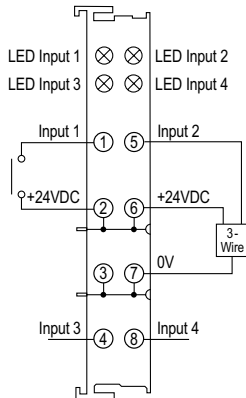

#### Terminal Specifications

Inputs Per Terminal	4
Input Type	Sinking
Input Data Bytes Used	1/2 byte (4-bits)
Input Power Source	24VDC provided via terminal power bus
Current Consumption (from Terminal Pwr Bus)	5mA typical
Operating Voltage Rating	24VDC (-15%/+20%)
Peak Voltage Rating	30VDC
ON Voltage Level	15 to 30 VDC
OFF Voltage Level	-3 to +5 VDC
Minimum ON Current	50mA
Maximum OFF Current	100mA
Current Consumption (from I/O Bus)	5mA typical
Electrical Isolation	500Vms (I/O bus/field potential)
Heat Dissipation	1W max
OFF to ON Response	3ms
ON to OFF Response	3ms
Status Indicators	4, indicates input is ON

#### General Specifications

Operating Temp	32 to 131 °F (0 to 55 °C)
Storage Temp	-13 to 185 °F (-25 to 85 °C)
Relative Humidity	5% to 95%, non-condensing
Environment Air	No corrosive gases permitted
Mounting/ Orientation Restrictions	35mm DIN rail/None
Vibration	Conforms to EN 60068-2-6
Shock	Conforms to EN 60068-2-27/ EN 60068-2-29
Noise Immunity	Conforms to EN 61000-6-2/ EN 61000-6-4
Protection Class	IP20
Dimensions (WxHxD)	12 x 100 x 68.8 mm (0.47 x 3.94 x 2.71 in)
Adjacent Mounting on Bus Terminals with Power Contact	Yes, DC only
Adjacent Mounting on Bus Terminals without Power Contact	No
Passes Terminal Bus Power	Yes
Passes PE Bus	No
Weight	55g (1.9 oz)
Agency Approvals*	UL/cUL File No. E157382, CE

\* To obtain the most current agency approval information, see the Agency Approval Checklist section on the specific part number's web page.

**PX-148:**  
**Eight-point, 24VDC Discrete Input Terminal**

The PX-148 (type 1) DC Input Terminal provides eight electrically isolated 24VDC sinking inputs with LED status.

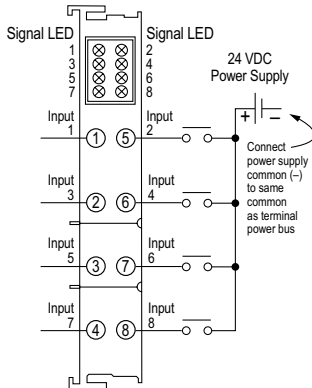

Terminal Specifications	
Inputs Per Terminal	8
Input Type	Sinking
Input Data Bytes Used	1-byte
Input Power Source	Requires external 24VDC power source
Current Consumption (from Terminal Power Bus)	2mA + load, typical
Operating Voltage Rating	24VDC (-15%/+20%)
Peak Voltage Rating	30VDC
ON Voltage Level	15 to 30 VDC
OFF Voltage Level	-3 to +5 VDC
Minimum ON Current	2.0 mA
Maximum OFF Current	1.5 mA
Current Consumption (from I/O Bus)	5mA typical
Electrical Isolation	500Vms (I/O bus/field potential)
Heat Dissipation	1W max
OFF to ON Response	3ms
ON to OFF Response	3ms
Status Indicators	8, indicates input is ON

General Specifications	
Operating Temp	32 to 131 °F (0 to 55 °C)
Storage Temp	-13 to 185 °F (-25 to 85 °C)
Relative Humidity	5% to 95%, non-condensing
Environment Air	No corrosive gases permitted
Mounting/ Orientation Restrictions	35mm DIN rail/None
Vibration	Conforms to EN 60068-2-6
Shock	Conforms to EN 60068-2-27/ EN 60068-2-29
Noise Immunity	Conforms to EN 61000-6-2/ EN 61000-6-4
Protection Class	IP20
Dimensions (WxHxD)	12 x 100 x 68.8 mm (0.47 x 3.94 x 2.71 in)
Adjacent Mounting on Bus Terminals with Power Contact	Yes, DC only
Adjacent Mounting on Bus Terminals without Power Contact	No
Passes Terminal Bus Power	Yes
Passes PE Bus	No
Weight	55g (1.9 oz)
Agency Approvals*	UL/cUL File No. E157382, CE

\* To obtain the most current agency approval information, see the Agency Approval Checklist section on the specific part number's web page.

### PX-149:

### Sixteen-point, 24VDC Discrete Input Terminal

The PX-149 (type 1) DC Input Terminal provides sixteen electrically isolated 24VDC sinking inputs with LED status.

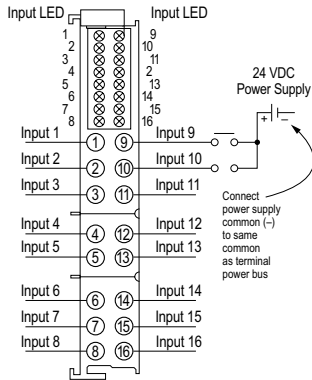

#### Terminal Specifications

Inputs Per Terminal	16
Input Type	Sinking
Input Data Bytes Used	2-bytes
Input Power Source	Requires external 24VDC power source
Current Consumption (from Terminal Power Bus)	NA
Operating Voltage Rating	24VDC (-15%/+20%)
Peak Voltage Rating	30VDC
ON Voltage Level	11 to 30 VDC
OFF Voltage Level	-3 to +5 VDC
Minimum ON Current	2mA
Maximum OFF Current	40mA
Current Consumption (from I/O Bus)	20mA typical
Electrical Isolation	500Vms (I/O bus/field potential)
Heat Dissipation	1W max
OFF to ON Response	3ms
ON to OFF Response	3ms
Status Indicators	16, indicates input is ON

#### General Specifications

Operating Temp	32 to 131 °F (0 to 55 °C)
Storage Temp	-13 to 185 °F (-25 to 85 °C)
Relative Humidity	5% to 95%, non-condensing
Environment Air	No corrosive gases permitted
Mounting/ Orientation Restrictions	35mm DIN rail/None
Vibration	Conforms to EN 60068-2-6
Shock	Conforms to EN 60068-2-27/ EN 60068-2-29
Noise Immunity	Conforms to EN 61000-6-2/ EN 61000-6-4
Protection Class	IP20
Dimensions (WxHxD)	12 x 100x 68.8 mm (0.47 x 3.94 x 2.71 in)
Adjacent Mounting on Bus Terminals with Power Contact	Yes, DC only
Adjacent Mounting on Bus Terminals without Power Contact	No
Passes Terminal Bus Power	Yes
Passes PE Bus	No
Weight	60g (2.1 oz)
Agency Approvals*	UL/cUL File No. E157382, CE

\* To obtain the most current agency approval information, see the Agency Approval Checklist section on the specific part number's web page.

**PX-172-1:  
Two-point, 120-230 VAC Discrete Input Terminal**

The PX-172-1 (type 2) DC Input Terminal provides two electrically isolated 120-230 VAC inputs with LED status. Intended for use with 4-wire, 3-wire and 2-wire devices.

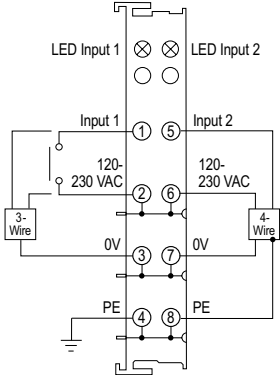

Note: Terminal PX-908 is recommended to isolate terminal power or use PX-970 to supply and isolate power.

Terminal Specifications	
Inputs Per Terminal	2
Input Type	NA
Input Data Bytes Used	1/4 byte (2-bits)
Input Power Source	Requires external 120-230 VAC power source. PX-908 terminal recommended to provide power to the terminal power bus.
Current Consumption (from Terminal Power Bus)	6mA typical
Operating Voltage Rating	120 to 230 VAC
Peak Voltage Rating	260VAC
ON Voltage Level	79 to 260 VAC
OFF Voltage Level	0 to 40 VAC
Minimum ON Current	250mA
Maximum OFF Current	500mA
Current Consumption (from I/O Bus)	3mA typical
Electrical Isolation	500Vms (I/O bus/field potential)
Heat Dissipation	1W max
OFF to ON Response	10ms
ON to OFF Response	10ms
Status Indicators	2, indicates input is ON

General Specifications	
Operating Temp	32 to 131 °F (0 to 55 °C)
Storage Temp	-13 to 185 °F (-25 to 85 °C)
Relative Humidity	5% to 95%, non-condensing
Environment Air	No corrosive gases permitted
Mounting/ Orientation Restrictions	35mm DIN rail/None
Vibration	Conforms to EN 60068-2-6
Shock	Conforms to EN 60068-2-27/ EN 60068-2-29
Noise Immunity	Conforms to EN 61000-6-2/ EN 61000-6-4
Protection Class	IP20
Dimensions (WxHxD)	12 x 100 x 68.8 mm (0.47 x 3.94 x 2.71 in)
Adjacent Mounting on Bus Terminals with Power Contact	Yes, AC only
Adjacent Mounting on Bus Terminals without Power Contact	No
Passes Terminal Bus Power	Yes
Passes PE Bus	Yes
Weight	60g (2.1 oz)
Agency Approvals*	UL/cUL File No. E157382, CE

\* To obtain the most current agency approval information, see the Agency Approval Checklist section on the specific part number's web page.

### PX-172-2:

### Two-point, 120 VAC/VDC Discrete Input Terminal

The PX-172-2 (type 2) DC Input Terminal provides two electrically isolated 120 VAC/VDC inputs with LED status. Intended for use with 4-wire, 3-wire and 2-wire devices.

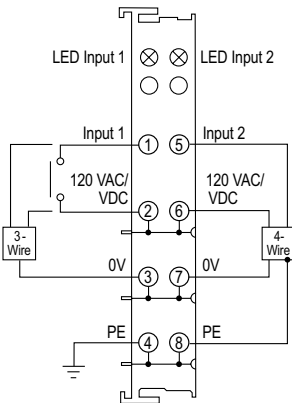

Note: Terminal PX-908 is recommended to isolate terminal power or use PX-970 to supply and isolate power.

#### Terminal Specifications

Inputs Per Terminal	2
Input Type	NA
Input Data Bytes Used	1/4 byte (2-bits)
Input Power Source	Requires external 120 VAC/VDC power source. PX-908 terminal recommended to provide power to the terminal power bus.
Current Consumption (from Terminal Power Bus)	6mA typical
Operating Voltage Rating	120 VAC/VDC
Peak Voltage Rating	140 VAC/VDC
ON Voltage Level	80 to 140 VAC/VDC
OFF Voltage Level	0 to 40 VAC/VDC
Minimum ON Current	250mA
Maximum OFF Current	500mA
Current Consumption (from I/O Bus)	3mA typical
Electrical Isolation	500Vms (I/O bus/field potential)
Heat Dissipation	1W max
OFF to ON Response	10ms
ON to OFF Response	10ms
Status Indicators	2, indicates input is ON

#### General Specifications

Operating Temp	32 to 131 °F (0 to 55 °C)
Storage Temp	-13 to 185 °F (-25 to 85 °C)
Relative Humidity	5% to 95%, non-condensing
Environment Air	No corrosive gases permitted
Mounting/ Orientation Restrictions	35mm DIN rail/None
Vibration	Conforms to EN 60068-2-6
Shock	Conforms to EN 60068-2-27/ EN 60068-2-29
Noise Immunity	Conforms to EN 61000-6-2/ EN 61000-6-4
Protection Class	IP20
Dimensions (WxHxD)	12 x 100 x 68.8 mm (0.47 x 3.94 x 2.71 in)
Adjacent Mounting on Bus Terminals with Power Contact	Yes, 120 VAC/VDC only
Adjacent Mounting on Bus Terminals without Power Contact	No
Passes Terminal Bus Power	Yes
Passes PE Bus	Yes
Weight	60g (2.1 oz)
Agency Approvals*	UL/cUL File No. E157382, CE

\* To obtain the most current agency approval information, see the Agency Approval Checklist section on the specific part number's web page.



### PX-244-1: Four-point, 0.5 A, 24VDC Discrete Output Terminal

The PX-244-1 (type 1) DC Output Terminal provides four 24VDC 0.5 A short-circuit protected sourcing outputs with LED status. Intended for use with 3-wire and 2-wire devices.

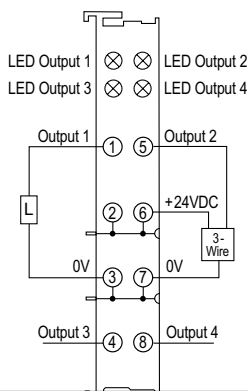

#### Terminal Specifications

Outputs Per Terminal	4
Commons Per Terminal	2
Output Type	Sourcing
Output Data Bytes Used	1/2 byte (4-bits)
Output Power Source	24VDC provided via terminal power bus
Current Consumption (from Load Voltage)	30mA typical
Operating Voltage	24VDC ( -15%/+20%)
Maximum Load Current	0.5 A per channel (Short-Circuit Protected)
On Voltage Drop	0.4 VDC @ 0.5 A
Maximum Leakage Current	300mA
Maximum Inrush Current	1.5 A
Maximum Short-Circuit Voltage	35V
Load Type	Resistive, inductive, lamp
Current Consumption (from I/O Bus)	9mA typical
Reverse Voltage Protection	No
Electrical Isolation	500Vms (I/O bus/field potential)
Heat Dissipation	1W max
OFF to ON Response	100ms max
ON to OFF Response	20ms max
Status Indicators	4, indicates output is ON

#### General Specifications

Operating Temp	32 to 131 °F (0 to 55 °C)
Storage Temp	-13 to 185 °F (-25 to 85 °C)
Relative Humidity	5% to 95%, non-condensing
Environment Air	No corrosive gases permitted
Mounting/ Orientation Restrictions	35mm DIN rail/None
Vibration	Conforms to EN 60068-2-6
Shock	Conforms to EN 60068-2-27/ EN 60068-2-29
Noise Immunity	Conforms to EN 61000-6-2/ EN 61000-6-4
Protection Class	IP20
Dimensions (WxHxD)	12 x 100 x 68.8 mm (0.47 x 3.94 x 2.71 in)
Adjacent Mounting on Bus Terminals with Power Contact	Yes, DC only
Adjacent Mounting on Bus Terminals without Power Contact	No
Passes Terminal Bus Power	Yes
Passes PE Bus	No
Weight	60g (2.1 oz)
Agency Approvals*	UL/cUL File No. E157382, CE

\* To obtain the most current agency approval information, see the Agency Approval Checklist section on the specific part number's web page.

### PX-244-2:

### Four-point, 2A, 24VDC Discrete Output Terminal

The PX-244-2 (type 1) DC Output Terminal provides four 24VDC 2A short-circuit protected sourcing outputs with LED status.

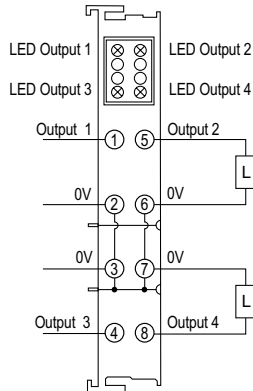

Terminal Specifications	
Outputs Per Terminal	4
Commons Per Terminal	4
Output Type	Sourcing
Output Data Bytes Used	1/2 byte (4-bits)
Output Power Source	24VDC provided via terminal power bus
Current Consumption (from Load Voltage)	30mA typical
Operating Voltage	24VDC ( -15%/+20%)
Maximum Load Current	2A per channel (Short-Circuit Protected)
On Voltage Drop	0.14 VDC @ 2A
Maximum Leakage Current	60mA
Maximum Inrush Current	35A
Maximum Short-Circuit Voltage	52V
Load Type	Resistive, inductive, lamp
Current Consumption (from I/O Bus)	9mA typical
Reverse Voltage Protection	Yes
Electrical Isolation	500Vms (I/O bus/field potential)
Heat Dissipation	1W max
OFF to ON Response	160ms typ, 300ms max
ON to OFF Response	10ms min, 80ms max
Status Indicators	4, indicates output is ON

General Specifications	
Operating Temp	32 to 131 °F (0 to 55 °C)
Storage Temp	-13 to 185 °F (-25 to 85 °C)
Relative Humidity	5% to 95%, non-condensing
Environment Air	No corrosive gases permitted
Mounting/ Orientation Restrictions	35mm DIN rail/None
Vibration	Conforms to EN 60068-2-6
Shock	Conforms to EN 60068-2-27/ EN 60068-2-29
Noise Immunity	Conforms to EN 61000-6-2/ EN 61000-6-4
Protection Class	IP20
Dimensions (WxHxD)	12 x 100 x 68.8 mm (0.47 x 3.94 x 2.71 in)
Adjacent Mounting on Bus Terminals with Power Contact	Yes, DC only
Adjacent Mounting on Bus Terminals without Power Contact	No
Passes Terminal Bus Power	Yes
Passes PE Bus	No
Weight	60g (2.1 oz)
Agency Approvals*	UL/cUL File No. E157382, CE

\* To obtain the most current agency approval information, see the Agency Approval Checklist section on the specific part number's web page.

### PX-248:

### Eight-point, 0.5 A, 24VDC Discrete Output Terminal

The PX-248 (type 1) DC Output Terminal provides eight 24VDC 0.5 A short-circuit protected sourcing outputs with LED status.

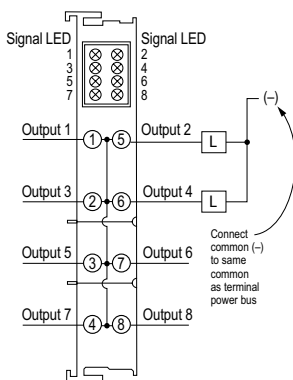

#### General Specifications

Operating Temp	32 to 131 °F (0 to 55 °C)
Storage Temp	-13 to 185 °F (-25 to 85 °C)
Relative Humidity	5% to 95%, non-condensing
Environment Air	No corrosive gases permitted
Mounting/ Orientation Restrictions	35mm DIN rail/None
Vibration	Conforms to EN 60068-2-6
Shock	Conforms to EN 60068-2-27/ EN 60068-2-29
Noise Immunity	Conforms to EN 61000-6-2/ EN 61000-6-4
Protection Class	IP20
Dimensions (WxHxD)	12 x 100 x 68.8 mm (0.47 x 3.94 x 2.71 in)
Adjacent Mounting on Bus Terminals with Power Contact	Yes, DC only
Adjacent Mounting on Bus Terminals without Power Contact	No
Passes Terminal Bus Power	Yes
Passes PE Bus	No
Weight	70g (2.5 oz)
Agency Approvals*	UL/cUL File No. E157382, CE

\* To obtain the most current agency approval information, see the Agency Approval Checklist section on the specific part number's web page.

#### Terminal Specifications

Outputs Per Terminal	8
Commons Per Terminal	Field wired
Output Type	Sourcing
Output Data Bytes Used	1-byte
Output Power Source	24VDC provided via terminal power bus
Current Consumption (from Load Voltage)	60mA + load typical
Operating Voltage	24VDC (-15%/+20%)
Maximum Load Current	0.5 A per channel (Short-Circuit Protected)
On Voltage Drop	0.4 VDC @ 0.5 A
Maximum Leakage Current	300mA
Maximum Inrush Current	1.5 A
Max. Short-Circuit Voltage	35V
Load Type	Resistive, inductive, lamp
Current Consumption (from I/O Bus)	18mA typical
Reverse Voltage Protection	Yes
Electrical Isolation	500Vms (I/O bus/field potential)
Heat Dissipation	1W max
OFF to ON Response	100ms max
ON to OFF Response	20ms max
Status Indicators	8, indicates output is ON

### PX-249:

### Sixteen-point, 0.5 A, 24VDC Discrete Output Terminal

The PX-249 (type 1) DC Output Terminal provides sixteen 24VDC 0.5 A short-circuit protected sinking outputs with LED status.

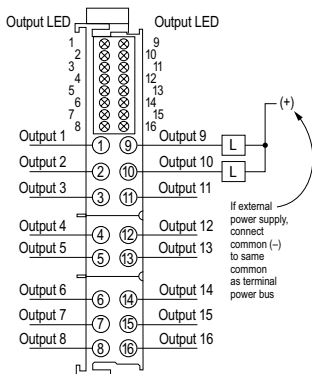

### General Specifications

Operating Temp	32 to 131 °F (0 to 55 °C)
Storage Temp	-13 to 185 °F (-25 to 85 °C)
Relative Humidity	5% to 95%, non-condensing
Environment Air	No corrosive gases permitted
Mounting/ Orientation Restrictions	35mm DIN rail/None
Vibration	Conforms to EN 60068-2-6
Shock	Conforms to EN 60068-2-27/ EN 60068-2-29
Noise Immunity	Conforms to EN 61000-6-2/ EN 61000-6-4
Protection Class	IP20
Dimensions (WxHxD)	12 x 100 x 68.8 mm (0.47 x 3.94 x 2.71 in)
Adjacent Mounting on Bus Terminals with Power Contact	Yes, DC only
Adjacent Mounting on Bus Terminals without Power Contact	No
Passes Terminal Bus Power	Yes
Passes PE Bus	No
Weight	70g (2.5 oz)
Agency Approvals*	UL/cUL File No. E157382, CE

\* To obtain the most current agency approval information, see the Agency Approval Checklist section on the specific part number's web page.

### Terminal Specifications

Outputs Per Terminal	16
Commons Per Terminal	Field wired
Output Type	Sinking
Output Data Bytes Used	2-bytes
Output Power Source	Requires external 24VDC power source
Current Consumption (from Load Voltage)	35mA + load typical
Operating Voltage	24VDC (-15%/+20%)
Maximum Load Current	0.5 A per channel (Short-Circuit Protected)
On Voltage Drop	0.12 VDC @ 0.5 A
Maximum Leakage Current	75mA
Maximum Inrush Current	3.5 A
Max. Short-Circuit Voltage	36V
Load Type	Resistive, inductive, lamp
Current Consumption (from I/O Bus)	45mA typical
Reverse Voltage Protection	Yes
Electrical Isolation	500Vms (I/O bus/field potential)
Heat Dissipation	1W max
OFF to ON Response	0.45 ms
ON to OFF Response	3.3 ms
Status Indicators	16, indicates output is ON

**PX-272-1:**

**Two-point, 0-230 VAC/VDC Discrete Solid State Relay Output Terminal**

The PX-272-1 (type 2) Relay Output Terminal provides two 230 VAC/ VDC 0.3 A outputs with LED status. Intended for use with 4-wire, 3-wire and 2-wire devices.

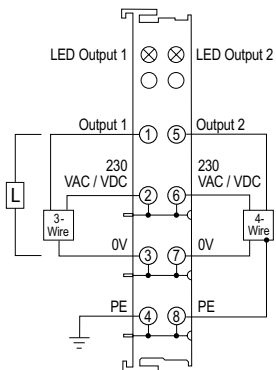

Note: Terminal PX-908 is recommended to isolate terminal power or use PX-970 to supply and isolate power.

General Specifications	
Operating Temp	32 to 131 °F (0 to 55 °C)
Storage Temp	-13 to 185 °F (-25 to 85 °C)
Relative Humidity	5% to 95%, non-condensing
Environment Air	No corrosive gases permitted
Mounting/ Orientation Restrictions	35mm DIN rail/None
Vibration	Conforms to EN 60068-2-6
Shock	Conforms to EN 60068-2-27/ EN 60068-2-29
Noise Immunity	Conforms to EN 61000-6-2/ EN 61000-6-4
Protection Class	IP20
Dimensions (WxHxD)	12 x 100 x 68.8 mm (0.47 x 3.94 x 2.71 in)
Adjacent Mounting on Bus Terminals with Power Contact	Yes, 230 VAC/VDC only
Adjacent Mounting on Bus Terminals without Power Contact	No
Passes Terminal Bus Power	Yes
Passes PE Bus	Yes
Weight	55g (1.9 oz)
Agency Approvals*	UL/cUL File No. E157382, CE

\* To obtain the most current agency approval information, see the Agency Approval Checklist section on the specific part number's web page.

Terminal Specifications	
Outputs Per Terminal	2
Commons Per Terminal	2
Output Type	Solid State Relay (DC sourcing only)
Output Data Bytes Used	1/4 byte (2-bits)
Output Power Source	230 VAC/VDC provided via terminal power bus
Current Consumption (from Terminal Power Bus)	(ON resistance max 100mV) + load
Operating Voltage	0 to 230 VAC/VDC (DC 100Hz)
Maximum Load Current	0.3 A per point
Maximum Leakage Current	< 1mA (off state)
Maximum Inrush Current	0.5 A for 20s, 1.5 A for 100ms
Contact Resistance	2.1 V, typical 3.2 V, max.
Surge Voltage Protection	From 400VAC
Load Type	Resistive, inductive
Current Consumption (from I/O Bus)	10mA
Electrical Isolation	500Vms (I/O bus/field potential) 2500VDC (1 min.)
Heat Dissipation	1W max
Switch-ON Time	4 to 6 ms
Switch-OFF Time	0.05 to 0.1 ms
Switch-ON Delay	320ms
Switch-OFF Delay	6.2 ms
Status Indicators	2, indicates output is ON

### PX-272-2:

### Two-point, 230VAC / 30VDC Discrete Relay Output Terminal

The PX-272-2 (type 2) Relay Output Terminal provides two 230VAC / 30VDC 5A outputs with LED status. Intended for use with 4-wire, 3-wire and 2-wire devices.

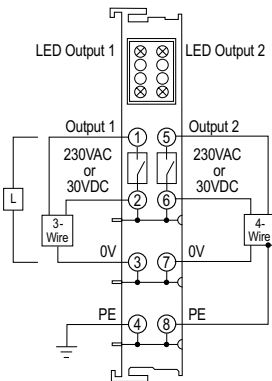

Note: Terminal PX-908 is recommended to isolate terminal power or use PX-970 to supply and isolate power.

#### General Specifications

Operating Temp	32 to 131 °F (0 to 55 °C)
Storage Temp	-13 to 185 °F (-25 to 85 °C)
Relative Humidity	5% to 95%, non-condensing
Environment Air	No corrosive gases permitted
Mounting/Orientation Restrictions	35mm DIN rail/None
Vibration	Conforms to EN 60068-2-6
Shock	Conforms to EN 60068-2-27/ EN 60068-2-29
Noise Immunity	Conforms to EN 61000-6-2/ EN 61000-6-4
Protection Class	IP20
Dimensions (WxHxD)	12 x 100 x 68.8 mm (0.47 x 3.94 x 2.71 in)
Adjacent Mounting on Bus Terminals with Power Contact	Yes, 230VAC or 30VDC only
Adjacent Mounting on Bus Terminals without Power Contact	No
Passes Terminal Bus Power	Yes
Passes PE Bus	Yes
Weight	85g (3.0 oz)
Agency Approvals*	UL/cUL File No. E157382, CE

#### Terminal Specifications

Outputs Per Terminal	2
Commons Per Terminal	2
Output Type	SPST Relay, normally open contact (DC sourcing only)
Output Data Bytes Used	1/4 byte (2-bits)
Output Power Source	230VAC/30VDC provided via terminal power bus
Current Consumption (from Terminal Power Bus)	(ON resistance typ 2.4 V, max 3.2 V) + load
Operating Voltage	230VAC/30VDC
Maximum Load Current	5A per point
Maximum Load Current with Resistive Load	AC: 5A @230VAC, 1250VA DC: 5A @ 30VDC, 150W
Maximum Load Current with Inductive Load, cosine = 0.4, L/R=7ms	AC: 2A @230VAC DC: 2A @ 30VDC
Minimum Load (approximate)	10mA @ 5VDC (as supplied) 100mA @ 20VDC (after approx. ≥ 100mA has been switched at least once)
Load Type	Resistive, inductive, lamp
Switching Times	Reaction Time: 10ms max. Release Time: 4ms max. Bounce Time: 5ms max.
Contact Material	Silver Cadmium Oxide
Current Consumption (from I/O Bus)	80mA
Electrical Isolation	500Vms (I/O bus/field potential) 2500VDC (1 min.)
Heat Dissipation	1W max
Switching Frequency at Maximum Contact Load	10/minute
Maximum Contact Resistance	< 30mV
Minimum Insulation Resistance	100MV @ 500VDC
Mechanical Operating Life	20,000,000 switching operations
Electrical Operating Life	Minimum 100,000 switching operations with resistive loads
Test Voltage Between Open Contacts	750V for 1 minute
Status Indicators	2, indicates output is ON

\* To obtain the most current agency approval information, see the Agency Approval Checklist section on the specific part number's web page.

### PX-549: Eight inputs/Eight outputs, 24VDC Discrete Input/Output Terminal

The PX-549 (type 1) DC Input/Output Terminal provides eight 24VDC inputs and eight 24VDC 0.5 A outputs with reverse polarity protection and LED status.

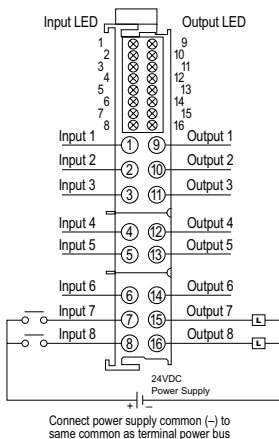

Terminal Specifications	
Inputs/Outputs Per Terminal	8 sinking inputs / 8 sourcing outputs
Data Bytes Used	1-byte (inputs) / 1-byte (outputs)
Input/Output Power Source	Requires external 24VDC power source
Operating Voltage Rating	24VDC (-15%/+20%)
Current Consumption (from I/O Bus)	25mA typical
Current Consumption (from Terminal Power Bus)	15mA + load typical
Electrical Isolation	500Vms (I/O bus/field potential)
Heat Dissipation	1W max
Status Indicators	8 input and 8 output, indicates ON
Input Specifications	
Peak Voltage Rating	30VDC
ON Voltage Level	15 to 30 VDC
OFF Voltage Level	-3 to +5 VDC
Minimum ON Current	2mA
Minimum OFF Current	40mA
Current Consumption (from I/O Bus)	3mA typical
OFF to ON Response	3ms
ON to OFF Response	3ms
Output Specifications	
Max. Load Current per Output	0.5 A (Short-Circuit Protected)
On Voltage Drop	0.14 VDC @ 2A
Maximum Leakage Current	5mA
Maximum Inrush Current	2A
Maximum Short-Circuit Voltage	45V
Load Type	Resistive, inductive, lamp
Reverse Voltage Protection	Yes
OFF to ON Response	50ms
ON to OFF Response	75ms

\* To obtain the most current agency approval information, see the Agency Approval Checklist section on the specific part number's web page.

General Specifications	
Operating Temp	32 to 131 °F (0 to 55 °C)
Storage Temp	-13 to 185 °F (-25 to 85 °C)
Relative Humidity	5% to 95%, non-condensing
Environment Air	No corrosive gases permitted
Mounting/ Orientation Restrictions	35mm DIN rail/None
Vibration	Conforms to EN 60068-2-6
Shock	Conforms to EN 60068-2-27/ EN 60068-2-29
Noise Immunity	Conforms to EN 61000-6-2/ EN 61000-6-4
Protection Class	IP20
Dimensions (WxHxD)	12 x 100 x 68.8 mm (0.47 x 3.94 x 2.71 in)
Adjacent Mounting on Bus Terminals with Power Contact	Yes, DC only
Adjacent Mounting on Bus Terminals without Power Contact	No
Passes Terminal Bus Power	Yes
Passes PE Bus	No
Weight	60g (2.1 oz)
Agency Approvals*	UL/cUL File No. E157382, CE

# Analog Terminals

## PX-302: Two-channel, 4-20 mA Analog Input Terminal

The PX-302 (type 3) Analog Input Terminal provides two electrically isolated 4-20 mA inputs with 12-bit resolution and Run and Error LED status.

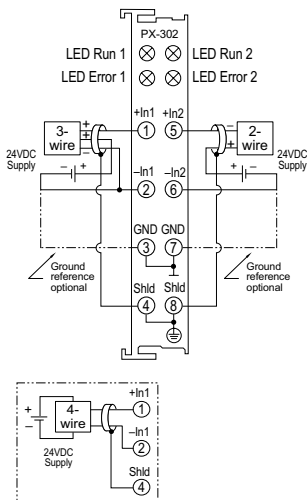

Terminal Specifications	
Number of Channels	2
Input Ranges	4 to 20 mA
Resolution	12 bits
Input Type	External ground reference
Data Format	Decimal: 0-32767
Data Bytes Consumed	PX-MOD: 4-bytes input PX-TCP1/TCP2: 8-bytes in/ 8-bytes out (not used)
Input Power Source	Loop power external
Current Consumption (from Terminal Power Bus)	NA
Input Impedance	50V internal resistor
Absolute Max Ratings	35VDC surge
Conversion Time	Approx. 2ms
Full Scale Calibration Error	± 0.3% of full scale
Current Consumption (from I/O Bus)	60mA
Electrical Isolation	500Vms (I/O bus/field potential)
Heat Dissipation	1W max
Status Indicators	4, see LED Status chart

General Specifications	
Operating Temp	32 to 131 °F (0 to 55 °C)
Storage Temp	-13 to 185 °F (-25 to 85 °C)
Relative Humidity	5% to 95%, non-condensing
Environment Air	No corrosive gases permitted
Mounting/ Orientation Restrictions	35mm DIN rail/None
Vibration	Conforms to EN 60068-2-6
Shock	Conforms to EN 60068-2-27/ EN 60068-2-29
Noise Immunity	Conforms to EN 61000-6-2/ EN 61000-6-4
Protection Class	IP20
Dimensions (WxHxD)	12 x 100 x 68.8 mm (0.47 x 3.94 x 2.71 in)
Adjacent Mounting on Bus Terminals with Power Contact	Yes
Adjacent Mounting on Bus Terminals without Power Contact	Yes
Passes Terminal Bus Power	No
Passes PE Bus	No
Weight	70g (2.5 oz)
Agency Approvals*	UL/cUL File No. E157382, CE

\* To obtain the most current agency approval information, see the Agency Approval Checklist section on the specific part number's web page.

LED Status		
LED	LED ON	LED OFF
Green LED: RUN	Normal Operation	Watchdog-timer overflow if no data transmitted within WD set time.
Red LED: ERROR	Broken wire or current is > 21.5 mA	Normal Operation



**PX-304:**  
**Four-channel, 4-20 mA Analog Input Terminal**

The PX-304 (type 1) Analog Input Terminal provides four electrically isolated 4–20 mA inputs with 12-bit resolution and Run and Error LED status.

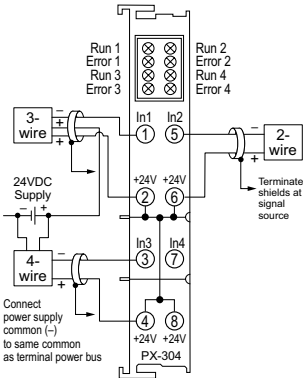

General Specifications	
Operating Temp	32 to 131 °F (0 to 55 °C)
Storage Temp	-13 to 185 °F (-25 to 85 °C)
Relative Humidity	5% to 95%, non-condensing
Environment Air	No corrosive gases permitted
Mounting/ Orientation Restrictions	35mm DIN rail/None
Vibration	Conforms to EN 60068-2-6
Shock	Conforms to EN 60068-2-27/ EN 60068-2-29
Noise Immunity	Conforms to EN 61000-6-2/ EN 61000-6-4
Protection Class	IP20
Dimensions (WxHxD)	12 x 100 x 68.8 mm (0.47 x 3.94 x 2.71 in)
Adjacent Mounting on Bus Terminals with Power Contact	Yes, DC only
Adjacent Mounting on Bus Terminals without Power Contact	No
Passes Terminal Bus Power	Yes
Passes PE Bus	No
Weight	75g (2.6 oz)
Agency Approvals*	UL/cUL File No. E157382, CE

\* To obtain the most current agency approval information, see the Agency Approval Checklist section on the specific part number's web page.

Terminal Specifications	
Number of Channels	4
Input Ranges	4 to 20 mA
Resolution	12 bits
Input Type	Single-ended
Data Format	Decimal: 0-32767
Data Bytes Consumed	PX-MOD: 8-bytes input PX-TCP1/TCP2: 16-bytes in/16-bytes out (not used)
Input Power Source	24VDC provided via terminal power bus
Current Consumption (from Terminal Power Bus)	Load
Input Impedance	< 85V
Absolute Max Ratings	30VDC surge
Conversion Time	Approx. 2ms
Full Scale Calibration Error	± 0.3% of full scale
Current Consumption (from I/O Bus)	85mA
Electrical Isolation	500Vms (I/O bus/field potential)
Heat Dissipation	1W max
Status Indicators	8, see LED Status chart

LED Status		
LED	LED ON	LED OFF
Green LED: RUN	Normal Operation	Watchdog-timer overflow if no data transmitted within WD set time.
Red LED: ERROR	Broken wire or current is > 20.8 mA	Normal Operation

### PX-308:

### Eight-channel, 4-20 mA Analog Input Terminal

The PX-308 (type 1) Analog Input Terminal provides eight electrically isolated 4-20 mA inputs with 12-bit resolution and Error LED status.

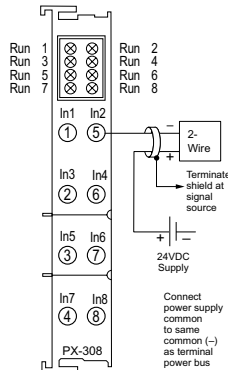

#### Terminal Specifications

Number of Channels	8
Input Ranges	4 to 20 mA
Resolution	12 bits
Input Type	Single-ended
Data Format	Decimal: 0-32767
Data Bytes Consumed	PX-MOD: 16-bytes input PX-TCP1/TCP2: 32-bytes in/32-bytes out (not used)
Input Power Source	Requires external 24VDC power source
Current Consumption (from Terminal Power Bus)	Load
Input Impedance	< 85V
Absolute Max Ratings	30VDC surge
Conversion Time	Approx. 4ms
Full Scale Calibration Error	± 0.3% of full scale
Current Consumption (from I/O Bus)	105mA
Electrical Isolation	500Vms (I/O bus/field potential)
Heat Dissipation	1W max
Status Indicators	8, Red: Error, broken wire or current is > 20.8 mA

#### General Specifications

Operating Temp	32 to 131 °F (0 to 55 °C)
Storage Temp	-13 to 185 °F (-25 to 85 °C)
Relative Humidity	5% to 95%, non-condensing
Environment Air	No corrosive gases permitted
Mounting/ Orientation Restrictions	35mm DIN rail/None
Vibration	Conforms to EN 60068-2-6
Shock	Conforms to EN 60068-2-27/ EN 60068-2-29
Noise Immunity	Conforms to EN 61000-6-2/ EN 61000-6-4
Protection Class	IP20
Dimensions (WxHxD)	12 x 100 x 68.8 mm (0.47 x 3.94 x 2.71 in)
Adjacent Mounting on Bus Terminals with Power Contact	Yes, DC only
Adjacent Mounting on Bus Terminals without Power Contact	No
Passes Terminal Bus Power	Yes
Passes PE Bus	No
Weight	75g (2.6 oz)
Agency Approvals*	UL/cUL File No. E157382, CE

\* To obtain the most current agency approval information, see the Agency Approval Checklist section on the specific part number's web page.

PX-312:

Two-channel, -10 to +10 VDC Analog Input Terminal

The PX-312 (type 3) Analog Input Terminal provides two electrically isolated -10 to +10 VDC inputs with 12-bit resolution and LED status.

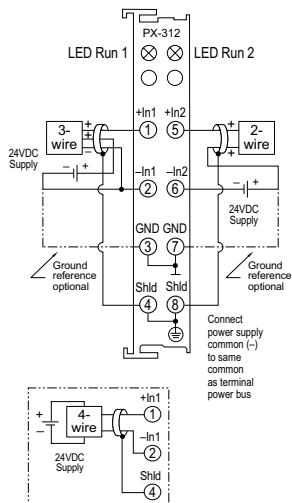

General Specifications	
Operating Temp	32 to 131 °F (0 to 55 °C)
Storage Temp	-13 to 185 °F (-25 to 85 °C)
Relative Humidity	5% to 95%, non-condensing
Environment Air	No corrosive gases permitted
Mounting/ Orientation Restrictions	35mm DIN rail/None
Vibration	Conforms to EN 60068-2-6
Shock	Conforms to EN 60068-2-27/ EN 60068-2-29
Noise Immunity	Conforms to EN 61000-6-2/ EN 61000-6-4
Protection Class	IP20
Dimensions (WxHxD)	12 x 100 x 68.8 mm (0.47 x 3.94 x 2.71 in)
Adjacent Mounting on Bus Terminals with Power Contact	Yes
Adjacent Mounting on Bus Terminals without Power Contact	Yes
Passes Terminal Bus Power	No
Passes PE Bus	No
Weight	70g (2.5 oz)
Agency Approvals*	UL/cUL File No. E157382, CE

Terminal Specifications	
Number of Channels	2
Input Ranges	-10 to +10 VDC
Resolution	12 bits (11 bits between 0–10 VDC)
Input Type	External ground reference
Data Format	Decimal: -32767 to +32767
Data Bytes Consumed	PX-MOD: 4-bytes input PX-TCP1/TCP2: 8-bytes in/ 8-bytes out (not used)
Input Power Source	Voltage source external
Current Consumption (from Terminal Power Bus)	NA
Input Impedance	> 200kV
Absolute Max Ratings	35VDC surge
Conversion Time	Approx. 2ms
Full Scale Calibration Error	± 0.3% of full scale
Current Consumption (from I/O Bus)	65mA
Electrical Isolation	500Vms (I/O bus/field potential)
Heat Dissipation	1W max
Status Indicators	2, indicates I/O Bus activity

\* To obtain the most current agency approval information, see the Agency Approval Checklist section on the specific part number's web page.

### PX-314:

### Four-channel, -10 to +10 VDC Analog Input Terminal

The PX-314 (type 1) Analog Input Terminal provides four electrically isolated -10 to +10 VDC inputs with 12-bit resolution and LED status.

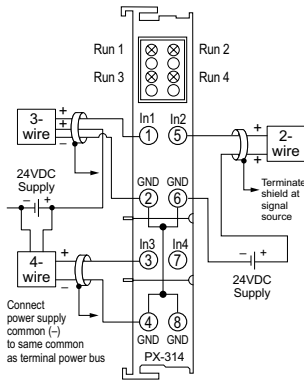

#### General Specifications

Operating Temp	32 to 131 °F (0 to 55 °C)
Storage Temp	-13 to 185 °F (-25 to 85 °C)
Relative Humidity	5% to 95%, non-condensing
Environment Air	No corrosive gases permitted
Mounting/ Orientation Restrictions	35mm DIN rail/None
Vibration	Conforms to EN 60068-2-6
Shock	Conforms to EN 60068-2-27/ EN 60068-2-29
Noise Immunity	Conforms to EN 61000-6-2/ EN 61000-6-4
Protection Class	IP20
Dimensions (WxHxD)	12 x 100 x 68.8 mm (0.47 x 3.94 x 2.71 in)
Adjacent Mounting on Bus Terminals with Power Contact	Yes, DC only
Adjacent Mounting on Bus Terminals without Power Contact	No
Passes Terminal Bus Power	Yes
Passes PE Bus	No
Weight	75g (2.6 oz)
Agency Approvals*	UL/cUL File No. E157382, CE

\* To obtain the most current agency approval information, see the Agency Approval Checklist section on the specific part number's web page.

#### Terminal Specifications

Number of Channels	4
Input Ranges	-10 to +10 VDC
Resolution	12 bits (11 bits between 0–10 VDC)
Input Type	Single-ended
Data Format	Decimal: -32767 to +32767
Data Bytes Consumed	PX-MOD: 8-bytes input PX-TCP1/TCP2: 16-bytes in/16-bytes out (not used)
Input Power Source	Voltage source external
Current Consumption (from Terminal Power Bus)	NA
Input Impedance	> 130kV
Absolute Max Ratings	30VDC surge
Conversion Time	Approx. 2ms
Full Scale Calibration Error	± 0.3% of full scale
Current Consumption (from I/O Bus)	100mA
Electrical Isolation	500Vms (I/O bus/field potential)
Heat Dissipation	1W max
Status Indicators	4, indicates I/O Bus activity

**PX-318:**  
**Eight-channel, -10 to +10 VDC Analog Input Terminal**

The PX-318 (type 1) Analog Input Terminal provides eight electrically isolated -10 to +10 VDC inputs with 12-bit resolution and LED status.

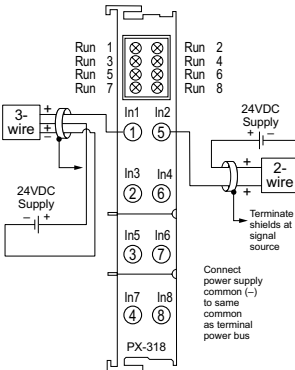

General Specifications	
Operating Temp	32 to 131 °F (0 to 55 °C)
Storage Temp	-13 to 185 °F (-25 to 85 °C)
Relative Humidity	5% to 95%, non-condensing
Environment Air	No corrosive gases permitted
Mounting/ Orientation Restrictions	35mm DIN rail/None
Vibration	Conforms to EN 60068-2-6
Shock	Conforms to EN 60068-2-27/ EN 60068-2-29
Noise Immunity	Conforms to EN 61000-6-2/ EN 61000-6-4
Protection Class	IP20
Dimensions (WxHxD)	12 x 100 x 68.8 mm (0.47 x 3.94 x 2.71 in)
Adjacent Mounting on Bus Terminals with Power Contact	Yes, DC only
Adjacent Mounting on Bus Terminals without Power Contact	No
Passes Terminal Bus Power	Yes
Passes PE Bus	No
Weight	75g (2.6 oz)
Agency Approvals*	UL/cUL File No. E157382, CE

Terminal Specifications	
Number of Channels	8
Input Ranges	-10 to +10 VDC
Resolution	12 bits (11 bits between 0 to 10 VDC)
Input Type	Single-ended
Data Format	Decimal: -32767 to +32767
Data Bytes Consumed	PX-MOD: 16-bytes input PX-TCP1/TCP2: 32-bytes in/32-bytes out (not used)
Input Power Source	Voltage source external
Current Consumption (from Terminal Pwr Bus)	NA
Input Impedance	> 130kV
Absolute Max Ratings	30VDC surge
Conversion Time	Approx. 4ms
Full Scale Calibration Error	± 0.3% of full scale
Current Consumption (from I/O Bus)	140mA
Electrical Isolation	500Vrms (I/O bus/field potential)
Heat Dissipation	1W max
Status Indicators	8, indicates I/O Bus activity

\* To obtain the most current agency approval information, see the Agency Approval Checklist section on the specific part number's web page.

### PX-322-1: Two-channel RTD Input Terminal

The PX-322-1 (type 3) RTD Input Terminal provides two PT100 RTD inputs with full linearization and LED status.

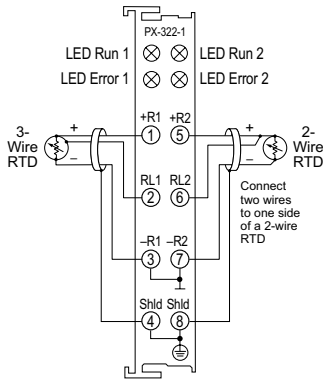

#### Terminal Specifications

Number of Channels	2
Range	-200 to 850 °C
Resolution	0.1 °C per digit
Input Type	PT100
Data Bytes Consumed	PX-MOD: 4-bytes input PX-TCP1/TCP2: 8-bytes in/8-bytes out (not used)
Connection Method	2-wire or 3-wire (3-wire default)
Power Supply	Via I/O Bus
Conversion Time	Approx. 250ms
Measuring Current	5mA typical
Linearity Error	< ± 1°C
Current Consumption (from I/O Bus)	60mA
Electrical Isolation	500Vrms (I/O bus/field potential)
Heat Dissipation	1W max
Status Indicators	4, see LED Status chart

#### General Specifications

Operating Temp	0 to 55 °C
Storage Temp	-25 to 85 °C
Relative Humidity	5% to 95%, non-condensing
Environment Air	No corrosive gases permitted
Mounting/ Orientation Restrictions	35mm DIN rail/None
Vibration	Conforms to EN 60068-2-6
Shock	Conforms to EN 60068-2-27/ EN 60068-2-29
Noise Immunity	Conforms to EN 61000-6-2/ EN 61000-6-4
Protection Class	IP20
Dimensions (WxHxD)	12 x 100 x 68.8 mm (0.47 x 3.94 x 2.71 in)
Adjacent Mounting on Bus Terminals with Power Contact	Yes
Adjacent Mounting on Bus Terminals without Power Contact	Yes
Passes Terminal Bus Power	No
Passes PE Bus	No
Weight	70g (2.5 oz)
Agency Approvals*	UL/cUL File No. E157382, CE

\* To obtain the most current agency approval information, see the Agency Approval Checklist section on the specific part number's web page.

#### LED Status

LED	LED ON	LED OFF
Green LED: RUN	Normal Operation	Watchdog-timer overflow if no data transmitted within WD set time.
Red LED: ERROR	Sensor fault, e.g. broken wire	No Error

**PX-324-1:  
Four-channel RTD Input Terminal**

The PX-324-1 (type 3) RTD Input Terminal provides four PT100 RTD inputs with full linearization and LED status.

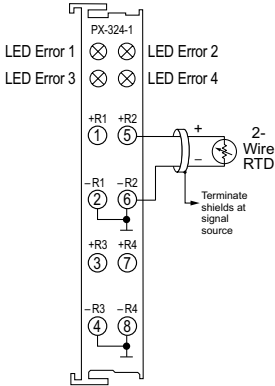

Terminal Specifications	
Number of Channels	4
Range	-200 to 850 °C
Resolution	0.1 °C per digit
Input Type	PT100
Data Bytes Consumed	PX-MOD: 8-bytes input PX-TCP1/TCP2: 16-bytes in/16-bytes out (not used)
Connection Method	2-wire
Power Supply	Via I/O Bus
Conversion Time	Approx. 250ms
Measuring Current	5mA typical
Linearity Error	< ± 1°C
Current Consumption (from I/O Bus)	60mA
Electrical Isolation	500Vms (I/O bus/field potential)
Heat Dissipation	1W max
Status Indicators	4, red, sensor fault

General Specifications	
Operating Temp	0 to 55 °C
Storage Temp	-25 to 85 °C
Relative Humidity	5% to 95%, non-condensing
Environment Air	No corrosive gases permitted
Mounting/ Orientation Restrictions	35mm DIN rail/None
Vibration	Conforms to EN 60068-2-6
Shock	Conforms to EN 60068-2-27/ EN 60068-2-29
Noise Immunity	Conforms to EN 61000-6-2/ EN 61000-6-4
Protection Class	IP20
Dimensions (WxHxD)	12 x 100 x 68.8 mm (0.47 x 3.94 x 2.71 in)
Adjacent Mounting on Bus Terminals with Power Contact	Yes
Adjacent Mounting on Bus Terminals without Power Contact	Yes
Passes Terminal Bus Power	No
Passes PE Bus	No
Weight	70g (2.5 oz)
Agency Approvals*	UL/cUL File No. E157382, CE

\* To obtain the most current agency approval information, see the Agency Approval Checklist section on the specific part number's web page.

### PX-332-J:

### Two-channel Type J Thermocouple Input Terminal

The PX-332-J (type 3) Thermocouple Input Terminal provides two Type J thermocouple inputs with full linearization, cold-junction compensation, and LED status.

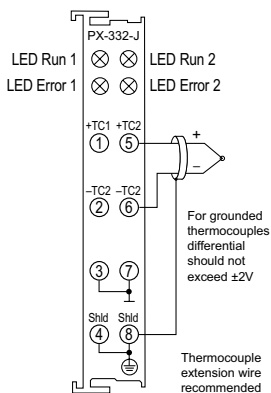

#### General Specifications

Operating Temp	0 to 55 °C
Storage Temp	-25 to 85 °C
Relative Humidity	5% to 95%, non-condensing
Environment Air	No corrosive gases permitted
Mounting/ Orientation Restrictions	35mm DIN rail/None
Vibration	Conforms to EN 60068-2-6
Shock	Conforms to EN 60068-2-27/ EN 60068-2-29
Noise Immunity	Conforms to EN 61000-6-2/ EN 61000-6-4
Protection Class	IP20
Dimensions (WxHxD)	12 x 100 x 68.8 mm (0.47 x 3.94 x 2.71 in)
Adjacent Mounting on Bus Terminals with Power Contact	Yes
Adjacent Mounting on Bus Terminals without Power Contact	Yes
Passes Terminal Bus Power	No
Passes PE Bus	No
Weight	70g (2.5 oz)
Agency Approvals*	UL/cUL File No. E157382, CE

\* To obtain the most current agency approval information, see the Agency Approval Checklist section on the specific part number's web page.

#### Terminal Specifications

Number of Channels	2
Range	-100 to 1200 °C
Resolution	0.1 °C per digit
Input Type	Type J thermocouple
Data Bytes Consumed	PX-MOD: 4-bytes input PX-TCP1/TCP2: 8-bytes in/8-bytes out (not used)
Connection Method	2-wire (Thermocouple extension wire recommended)
Power Supply	Via I/O Bus
Conversion Time	Approx. 250ms
Measuring Current	5mA typical
Linearity Error	± 0.5% (relative to full scale value)
Current Consumption (from I/O Bus)	65mA
Electrical Isolation	500Vms (I/O bus/field potential)
Heat Dissipation	1W max
Status Indicators	4, see LED Status chart

#### LED Status

LED	LED ON	LED OFF
Green LED: RUN	Normal Operation	Watchdog-timer overflow if no data transmitted within WD set time.
Red LED: ERROR	Sensor fault, e.g. broken wire	No Error



**PX-334-J:**  
**Four-channel Type J Thermocouple Input Terminal**

The PX-334-J (type 3) Thermocouple Input Terminal provides four Type J thermocouple inputs with full linearization, cold-junction compensation, and LED status.

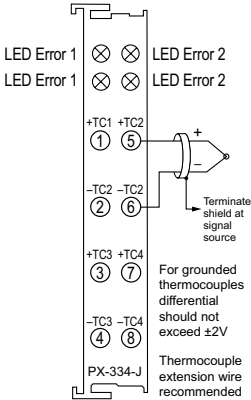

General Specifications	
Operating Temp	0 to 55 °C
Storage Temp	-25 to 85 °C
Relative Humidity	5% to 95%, non-condensing
Environment Air	No corrosive gases permitted
Mounting/ Orientation Restrictions	35mm DIN rail/None
Vibration	Conforms to EN 60068-2-6
Shock	Conforms to EN 60068-2-27/ EN 60068-2-29
Noise Immunity	Conforms to EN 61000-6-2/ EN 61000-6-4
Protection Class	IP20
Dimensions (WxHxD)	12 x 100 x 68.8 mm (0.47 x 3.94 x 2.71 in)
Adjacent Mounting on Bus Terminals with Power Contact	Yes
Adjacent Mounting on Bus Terminals without Power Contact	Yes
Passes Terminal Bus Power	No
Passes PE Bus	No
Weight	70g (2.5 oz)
Agency Approvals*	UL/cUL File No. E157382, CE

\* To obtain the most current agency approval information, see the Agency Approval Checklist section on the specific part number's web page.

Terminal Specifications	
Number of Channels	4
Range	-100 to 1200 °C
Resolution	0.1 °C per digit
Input Type	Type J thermocouple
Data Bytes Consumed	PX-MOD: 8-bytes input
	PX-TCP1/TCP2: 16-bytes in/16-bytes out (not used)
Connection Method	2-wire (Thermocouple extension wire recommended)
Power Supply	Via I/O Bus
Conversion Time	Approx. 250ms
Measuring Current	5mA typical
Linearity Error	± 0.5% (relative to full scale value)
Current Consumption (from I/O Bus)	75mA
Electrical Isolation	500Vms (I/O bus/field potential)
Heat Dissipation	1W max
Status Indicators	4, red, sensor fault/ broken wire

### PX-332-K:

### Two-channel Type K Thermocouple Input Terminal

The PX-332-K (type 3) Thermocouple Input Terminal provides two Type K thermocouple inputs with full linearization, cold-junction compensation, and LED status.

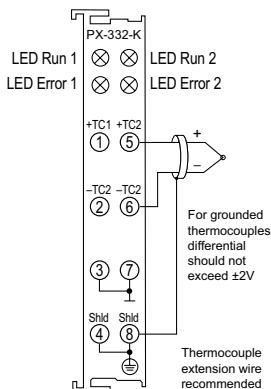

Terminal Specifications	
Number of Channels	2
Range	-100 to 1370 °C
Resolution	0.1 °C per digit
Input Type	Type K thermocouple
Data Bytes Consumed	PX-MOD: 4-bytes input PX-TCP1/TCP2: 8-bytes in/8-bytes out (not used)
Connection Method	2-wire (Thermocouple extension wire recommended)
Power Supply	Via I/O Bus
Conversion Time	Approx. 250ms
Measuring Current	5mA typical
Linearity Error	± 0.5% (relative to full scale value)
Current Consumption (from I/O Bus)	65mA
Electrical Isolation	500Vrms (I/O bus/field potential)
Heat Dissipation	1W max
Status Indicators	4, see LED Status chart

General Specifications	
Operating Temp	0 to 55 °C
Storage Temp	-25 to 85 °C
Relative Humidity	5% to 95%, non-condensing
Environment Air	No corrosive gases permitted
Mounting/ Orientation Restrictions	35mm DIN rail/None
Vibration	Conforms to EN 60068-2-6
Shock	Conforms to EN 60068-2-27/ EN 60068-2-29
Noise Immunity	Conforms to EN 61000-6-2/ EN 61000-6-4
Protection Class	IP20
Dimensions (WxHxD)	12 x 100 x 68.8 mm (0.47 x 3.94 x 2.71 in)
Adjacent Mounting on Bus Terminals with Power Contact	Yes
Adjacent Mounting on Bus Terminals without Power Contact	Yes
Passes Terminal Bus Power	No
Passes PE Bus	No
Weight	70g (2.5 oz)
Agency Approvals*	UL/cUL File No. E157382, CE

\* To obtain the most current agency approval information, see the Agency Approval Checklist section on the specific part number's web page.

LED Status		
LED	LED ON	LED OFF
Green LED: RUN	Normal Operation	Watchdog-timer overflow if no data transmitted within WD set time.
Red LED: ERROR	Sensor fault, e.g. broken wire	No Error

**PX-334-K:  
Four-channel Type K Thermocouple Input Terminal**

The PX-334-K (type 3) Thermocouple Input Terminal provides four Type K thermocouple inputs with full linearization, cold-junction compensation, and LED status.

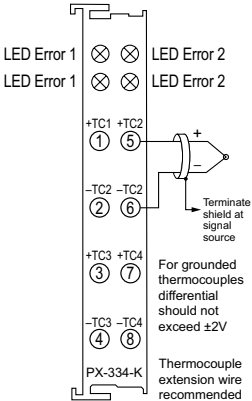

General Specifications	
Operating Temp	0 to 55 °C
Storage Temp	-25 to 85 °C
Relative Humidity	5% to 95%, non-condensing
Environment Air	No corrosive gases permitted
Mounting/ Orientation Restrictions	35mm DIN rail/None
Vibration	Conforms to EN 60068-2-6
Shock	Conforms to EN 60068-2-27/ EN 60068-2-29
Noise Immunity	Conforms to EN 61000-6-2/ EN 61000-6-4
Protection Class	IP20
Dimensions (WxHxD)	12 x 100 x 68.8 mm (0.47 x 3.94 x 2.71 in)
Adjacent Mounting on Bus Terminals with Power Contact	Yes
Adjacent Mounting on Bus Terminals without Power Contact	Yes
Passes Terminal Bus Power	No
Passes PE Bus	No
Weight	70g (2.5 oz)
Agency Approvals*	UL/cUL File No. E157382, CE

\* To obtain the most current agency approval information, see the Agency Approval Checklist section on the specific part number's web page.

Terminal Specifications	
Number of Channels	4
Range	-100 to 1370 °C
Resolution	0.1 °C per digit
Input Type	Type K thermocouple
Data Bytes Consumed	PX-MOD: 8-bytes input PX-TCP1/TCP2: 16-bytes in/16-bytes out (not used)
Connection Method	2-wire (Thermocouple extension wire recommended)
Power Supply	Via I/O Bus
Conversion Time	Approx. 250ms
Measuring Current	5mA typical
Linearity Error	± 0.5% (relative to full scale value)
Current Consumption (from I/O Bus)	75mA
Electrical Isolation	500Vms (I/O bus/field potential)
Heat Dissipation	1W max
Status Indicators	4, red, sensor fault/ broken wire

### PX-402:

### Two-channel, 4-20 mA Analog Output Terminal

The PX-402 (type 1) Analog Output Terminal provides two electrically isolated, 4-20 mA outputs with 12-bit resolution and Run LED status.

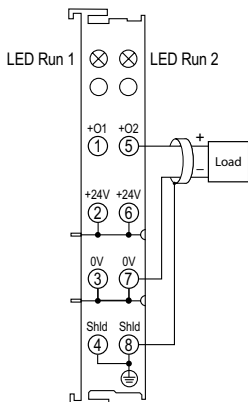

Terminal Specifications	
Number of Channels	2
Output Ranges	4 to 20 mA
Resolution	12 bit
Output Type	Single-ended
Data Format	Decimal: 0-32767
Data Bytes Consumed	PX-MOD: 4-bytes output PX-TCP1/TCP2: 8-bytes out/8-bytes in (not used)
Output Power Source	24VDC via terminal power bus
Current Consumption (from Load Voltage)	50mA + load
Source Load	< 500Ω (short-circuit protected)
Conversion Time	Approx. 1.5 ms
Accuracy	± 0.5 LSB linearity error, ± 0.5 LSB offset error ± 0.1% of the full scale value
I/O Bus current Consumption (5V)	60mA
Electrical Isolation	500Vms (I/O Bus/signal voltage)
Heat Dissipation	1W max
Status Indicators	2, see LED Status chart

General Specifications	
Operating Temp	32 to 131 °F (0 to 55 °C)
Storage Temp	-13 to 185 °F (-25 to 85 °C)
Relative Humidity	5% to 95%, non-condensing
Environment Air	No corrosive gases permitted
Mounting/ Orientation Restrictions	35mm DIN rail/None
Vibration	Conforms to EN 60068-2-6
Shock	Conforms to EN 60068-2-27/ EN 60068-2-29
Noise Immunity	Conforms to EN 61000-6-2/ EN 61000-6-4
Protection Class	IP20
Dimensions (WxHxD)	12 x 100 x 68.8 mm (0.47 x 3.94 x 2.71 in)
Adjacent Mounting on Bus Terminals with Power Contact	Yes, DC only
Adjacent Mounting on Bus Terminals without Power Contact	No
Passes Terminal Bus Power	Yes
Passes PE Bus	No
Weight	80g (2.8 oz)
Agency Approvals*	UL/cUL File No. E157382, CE

\* To obtain the most current agency approval information, see the Agency Approval Checklist section on the specific part number's web page.

LED Status		
LED	LED ON	LED OFF
Green LED: RUN	Normal Operation	Watchdog-timer overflow if no data transmitted within WD set time.

**PX-404:**  
**Four-channel, 4-20 mA Analog Output Terminal**

The PX-404 (type 1) Analog Output Terminal provides four electrically isolated, 4-20 mA outputs with 12-bit resolution and Run LED status.

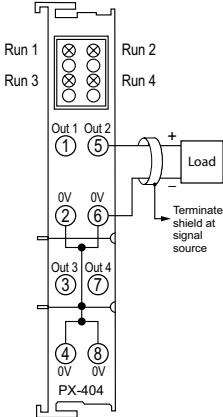

Terminal Specifications	
Number of Channels	4
Output Ranges	4 to 20 mA
Resolution	12 bit
Output Type	Single-ended
Data Format	Decimal: 0-32767
Data Bytes Consumed	PX-MOD: 8-bytes output
	PX-TCP1/TCP2: 16-bytes out/16-bytes in (not used)
Output Power Source	24VDC via terminal power bus
Current Consumption (from Load Voltage)	60mA + load
Source Load	< 350Ω (short-circuit protected)
Conversion Time	Approx. 4ms
Accuracy	± 0.5 LSB linearity error,
	± 0.5 LSB offset error
	± 0.1% of the full scale value
I/O Bus current Consumption (5V)	20mA
Electrical Isolation	500Vms (I/O Bus/signal voltage)
Heat Dissipation	1W max
Status Indicators	4, see LED Status chart

General Specifications	
Operating Temp	32 to 131 °F (0 to 55 °C)
Storage Temp	-13 to 185 °F (-25 to 85 °C)
Relative Humidity	5% to 95%, non-condensing
Environment Air	No corrosive gases permitted
Mounting/ Orientation Restrictions	35mm DIN rail/None
Vibration	Conforms to EN 60068-2-6
Shock	Conforms to EN 60068-2-27/ EN 60068-2-29
Noise Immunity	Conforms to EN 61000-6-2/ EN 61000-6-4
Protection Class	IP20
Dimensions (WxHxD)	12 x 100 x 68.8 mm (0.47 x 3.94 x 2.71 in)
Adjacent Mounting on Bus Terminals with Power Contact	Yes, DC only
Adjacent Mounting on Bus Terminals without Power Contact	No
Passes Terminal Bus Power	Yes
Passes PE Bus	No
Weight	80g (2.8 oz)
Agency Approvals*	UL/cUL File No. E157382, CE

\* To obtain the most current agency approval information, see the Agency Approval Checklist section on the specific part number's web page.

LED Status		
LED	LED ON	LED OFF
Green LED: RUN	Normal Operation	Watchdog-timer overflow if no data transmitted within WD set time.

### PX-408: Eight-channel, 4-20 mA Analog Output Terminal

The PX-408 (type 1) Analog Output Terminal provides eight electrically isolated, 4-20 mA outputs with 12-bit resolution and Run LED status.

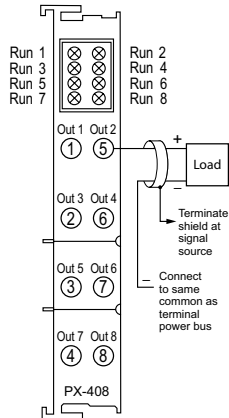

#### Terminal Specifications

Number of Channels	8
Output Ranges	4 to 20 mA
Resolution	12 bit
Output Type	Single-ended
Data Format	Decimal: 0-32767
Data Bytes Consumed	PX-MOD: 16-bytes output PX-TCP1/TCP2: 32-bytes out/32-bytes in (not used)
Output Power Source	24VDC via terminal power bus
Current Consumption (from Load Voltage)	50mA + load
Source Load	< 150Ω (short-circuit protected)
Conversion Time	Approx. 8ms
Accuracy	± 0.5 LSB linearity error, ± 0.5 LSB offset error ± 0.1% of the full scale value
I/O Bus current Consumption (5V)	25mA
Electrical Isolation	500Vms (I/O Bus/signal voltage)
Heat Dissipation	1W max
Status Indicators	8, see LED Status chart

#### General Specifications

Operating Temp	32 to 131 °F (0 to 55 °C)
Storage Temp	-13 to 185 °F (-25 to 85 °C)
Relative Humidity	5% to 95%, non-condensing
Environment Air	No corrosive gases permitted
Mounting/ Orientation Restrictions	35mm DIN rail/None
Vibration	Conforms to EN 60068-2-6
Shock	Conforms to EN 60068-2-27/ EN 60068-2-29
Noise Immunity	Conforms to EN 61000-6-2/ EN 61000-6-4
Protection Class	IP20
Dimensions (WxHxD)	12 x 100 x 68.8 mm (0.47 x 3.94 x 2.71 in)
Adjacent Mounting on Bus Terminals with Power Contact	Yes, DC only
Adjacent Mounting on Bus Terminals without Power Contact	No
Passes Terminal Bus Power	Yes
Passes PE Bus	No
Weight	80g (2.8 oz)
Agency Approvals*	UL/cUL File No. E157382, CE

\* To obtain the most current agency approval information, see the Agency Approval Checklist section on the specific part number's web page.

#### LED Status

LED	LED ON	LED OFF
Green LED: RUN	Normal Operation	Watchdog error if no data transmitted within WD set time.

**PX-412:**

**Two-channel, 0 to 10 VDC Analog Output Terminal**

The PX-412 (type 3) Analog Output Terminal provides two electrically isolated, 0 to 10 VDC outputs with 12-bit resolution, common ground potential, and Run LED status.

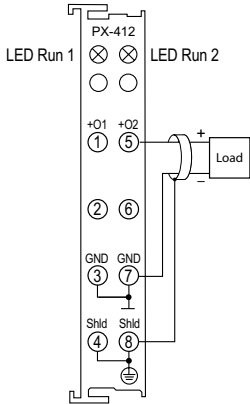

Terminal Specifications	
Number of Channels	2
Output Ranges	0 to 10 VDC
Resolution	12 bit
Output Type	Single-ended
Data Format	Decimal: 0-32767
Data Bytes Consumed	PX-MOD: 4-bytes output
	PX-TCP1/TCP2: 8-bytes out/8-bytes in (not used)
Output Power Source	24VDC via terminal power bus
Current Consumption (from Load Voltage)	50mA + load
Source Load	> 5kV (short-circuit protected)
Conversion Time	Approx. 1.5 ms
Accuracy	± 0.5 LSB linearity error, ± 0.5 LSB offset error ± 0.1% of the full scale value
I/O Bus current Consumption (5V)	75mA
Electrical Isolation	500Vms (I/O Bus/signal voltage)
Heat Dissipation	1W max
Status Indicators	2, see LED Status chart

General Specifications	
Operating Temp	32 to 131 °F (0 to 55 °C)
Storage Temp	-13 to 185 °F (-25 to 85 °C)
Relative Humidity	5% to 95%, non-condensing
Environment Air	No corrosive gases permitted
Mounting/ Orientation Restrictions	35mm DIN rail/None
Vibration	Conforms to EN 60068-2-6
Shock	Conforms to EN 60068-2-27/ EN 60068-2-29
Noise Immunity	Conforms to EN 61000-6-2/ EN 61000-6-4
Protection Class	IP20
Dimensions (WxHxD)	12 x 100 x 68.8 mm (0.47 x 3.94 x 2.71 in)
Adjacent Mounting on Bus Terminals with Power Contact	Yes
Adjacent Mounting on Bus Terminals without Power Contact	Yes
Passes Terminal Bus Power	No
Passes PE Bus	No
Weight	85g (3.0 oz)
Agency Approvals*	UL/cUL File No. E157382, CE

\* To obtain the most current agency approval information, see the Agency Approval Checklist section on the specific part number's web page.

LED Status		
LED	LED ON	LED OFF
Green LED: RUN	Normal Operation	Watchdog error if no data transmitted within WD set time.

### PX-414:

### Four-channel, 0 to 10 VDC Analog Output Terminal

The PX-414 (type 1) Analog Output Terminal provides four electrically isolated, 0 to 10 VDC outputs with 12-bit resolution, common ground potential, and Run LED status.

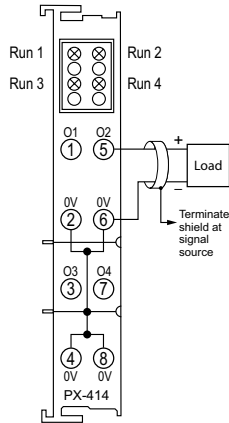

#### Terminal Specifications

Number of Channels	4
Output Ranges	0 to 10 VDC
Resolution	12 bit
Output Type	Single-ended
Data Format	Decimal: 0-32767
Data Bytes Consumed	PX-MOD: 8-bytes output PX-TCP1/TCP2: 16-bytes out/16-bytes in (not used)
Output Power Source	24VDC via terminal power bus
Current Consumption (from Load Voltage)	50mA + load
Source Load	> 5kV (short-circuit protected)
Conversion Time	Approx. 1.5 ms
Accuracy	± 0.5 LSB linearity error, ± 0.5 LSB offset error ± 0.1% of the full scale value
I/O Bus current Consumption (5V)	75mA
Electrical Isolation	500Vms (I/O Bus/signal voltage)
Heat Dissipation	1W max
Status Indicators	2, see LED Status chart

#### General Specifications

Operating Temp	32 to 131 °F (0 to 55 °C)
Storage Temp	-13 to 185 °F (-25 to 85 °C)
Relative Humidity	5% to 95%, non-condensing
Environment Air	No corrosive gases permitted
Mounting/ Orientation Restrictions	35mm DIN rail/None
Vibration	Conforms to EN 60068-2-6
Shock	Conforms to EN 60068-2-27/ EN 60068-2-29
Noise Immunity	Conforms to EN 61000-6-2/ EN 61000-6-4
Protection Class	IP20
Dimensions (WxHxD)	12 x 100 x 68.8 mm (0.47 x 3.94 x 2.71 in)
Adjacent Mounting on Bus Terminals with Power Contact	Yes, DC only
Adjacent Mounting on Bus Terminals without Power Contact	Yes
Passes Terminal Bus Power	No
Passes PE Bus	No
Weight	85g (3.0 oz)
Agency Approvals*	UL/cUL File No. E157382, CE

\* To obtain the most current agency approval information, see the Agency Approval Checklist section on the specific part number's web page.

#### LED Status

LED	LED ON	LED OFF
Green LED: RUN	Normal Operation	Watchdog error if no data transmitted within WD set time.



**PX-418:**  
**Eight-channel, -10 to +10 VDC Analog Output Terminal**

The PX-418 (type 1) Analog Output Terminal provides eight electrically isolated, -10 to +10 VDC outputs with 12-bit resolution, common ground potential, and Run LED status.

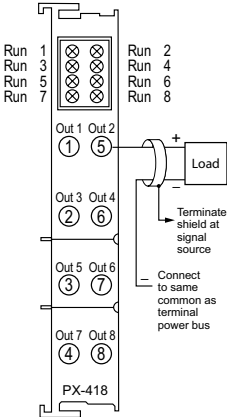

Terminal Specifications	
Number of Channels	8
Output Ranges	-10 to +10 VDC
Resolution	12 bit
Output Type	Single-ended
Data Format	Decimal: 0-32767
Data Bytes Consumed	PX-MOD: 16-bytes output PX-TCP1/TCP2: 32-bytes out/32-bytes in (not used)
Output Power Source	24VDC via terminal power bus
Current Consumption (from Load Voltage)	20mA
Source Load	> 5kV (short-circuit protected)
Conversion Time	Approx. 8ms
Accuracy	± 0.5 LSB linearity error, ± 0.5 LSB offset error ± 0.1% of the full scale value
I/O Bus current Consumption (5V)	20mA
Electrical Isolation	500Vms (I/O Bus/signal voltage)
Heat Dissipation	1W max
Status Indicators	8, see LED Status chart

General Specifications	
Operating Temp	32 to 131 °F (0 to 55 °C)
Storage Temp	-13 to 185 °F (-25 to 85 °C)
Relative Humidity	5% to 95%, non-condensing
Environment Air	No corrosive gases permitted
Mounting/ Orientation Restrictions	35mm DIN rail/None
Vibration	Conforms to EN 60068-2-6
Shock	Conforms to EN 60068-2-27/ EN 60068-2-29
Noise Immunity	Conforms to EN 61000-6-2/ EN 61000-6-4
Protection Class	IP20
Dimensions (WxHxD)	12 x 100 x 68.8 mm (0.47 x 3.94 x 2.71 in)
Adjacent Mounting on Bus Terminals with Power Contact	Yes, DC only
Adjacent Mounting on Bus Terminals without Power Contact	No
Passes Terminal Bus Power	Yes
Passes PE Bus	No
Weight	85g (3.0 oz)
Agency Approvals*	UL/cUL File No. E157382, CE

\* To obtain the most current agency approval information, see the Agency Approval Checklist section on the specific part number's web page.

LED Status		
LED	LED ON	LED OFF
Green LED: RUN	Normal Operation	Watchdog error if no data transmitted within WD set time.

### Protos X Modbus Communication

The Protos X system is designed as a Modbus Server/Client configuration, with Bus Coupler Terminals serving as Servers, and a PLC or PC controller as the Client. Control is through the Client using standard Modbus RTU or TCP protocol via serial or Ethernet communications.

Configuration is done through the Protos X Configuration Software. Modbus addresses are automatically assigned based on I/O Terminal type and placement within an assembly.

The following Modbus functions are supported with the Protos X Bus Couplers.

Supported Modbus Function Codes		
Function Code	Function	Description
1	Read Coil Status	Read input and output bits as an octet string.
2	Read Input Status	Read input bit as an octet string.
3	Read Holding Registers	Read number of input words.
4	Read Input Registers	Read number of input words.
5	Force Single Coil	Write output bit.
6	Preset Single Register	Writes a value in an output word.
15	Force Multiple Coils	Writes a number of output bits.
16	Preset Multiple Registers	Writes a number of output words.

**Protos X EtherNet/IP Communication**

The Protos X EtherNet/IP module uses IO Messaging to communicate as an adapter device. The data that is transported is defined as Input data and Output data. Don't confuse this type of data with what most PLCs define as Inputs and Outputs. In most PLCs, Inputs are typically associated with an Input module that reads values from real word devices. Outputs are typically associated with an Output module that turns real word devices off and on.

In IO Messaging, Input data is data that is sent from the target device back to the Scanner (Originator) or to multiple devices that are listening (multicast messages). Output data is data that is sent from the Adapter (Target) device. This data may or may not be connected to real word devices. That is completely dependent upon the Adapter device. For example, since Protos X is an EtherNet/IP Adapter device, the Input data and Output data is defined in internal registers and does not directly tie to any Input and Output point to the real world. If it is desired to tie these elements to real word devices, that must be accomplished in code in the Scanner device.

**Protos X EtherNet/IP Communication**

The terminology associated with EtherNet/IP may be confusing. To better understand this nomenclature, some of the frequently used terms are listed below with a brief descriptive definition.

**Scanner:** This is the term used to describe the device that initiates the EtherNet/IP sessions. The Scanner is sometimes referred to as the "Originator" as well. In more standard Ethernet terms, the Scanner would often be called the "Client".

**Adapter:** This is the device that responds to the EtherNet/IP communications that are initiated by the Scanner. The Adapter is also known as the "Target" as well. Typically, the Adapter is an Ethernet "Server".

**Connection Point (Assembly Instance):** A Connection Point value is the "Class Code" reference for a data block. This value is required for access to input and output data in IO Messaging. It is typically defined for each input and output data block by the Adapter device manufacturer.

**IO Messaging:** IO Messaging (also called "Implicit Messaging") is a method of reading and writing blocks of data without defining the Connection Point and size for each block transfer. The Connection Point, size and transfer rate (RPI) are defined at the beginning and then the data blocks are transferred at the specified intervals.

Communication Format	
Integer 8 bit Unsigned, Integer 16 bit, or Integer 32 bit	
Assembly Instance	Size
Input: 100	(4xINT 8 (Byte) or 2xINT 16 or 1xINT 32) + terminals
Output: 102	(4xINT 8 (Byte) or 2xINT 16 or 1xINT 32) + terminals
Configuration: 100	0

### Protos X PX-EIP1 Status / Control Words

ProtosX PX-EIP1 Status/Control Words			
	Byte	Bit	Function
Input	0	0	Active if bus error present
	0	1	No function
	0	2	Reserved
	0	3	Reserved
	0	4	No function
	0	5	No function
	0	6	No function
	0	7	No function
	1	-	Bus counter - increments from 0-255 and repeats
	2	-	Bus error code
	3	-	Bus error argument
Output	0	0	0->1 triggers bus reset
	0	1	1->0 reboots bus coupler
	0	2	Reserved
	0	3	Reserved
	0	4	No function
	0	5	No function
	0	6	No function
	0	7	No function
	1	-	No function
	2	-	No function
	3	-	No function

## Protos X PX-EIP1 Error Codes

ProtosX PX-EIP1 Error Codes			
Error Code	Error Argument	Description	Remedy
1	0	EEPROM checksum error	Reload configuration in ProtosX Configuration Software
	1	Code buffer overflow	Insert fewer bus terminals. The programmed configuration has too many entries in the table
	2	Unknown data type	Software update required for bus coupler
2	1	Programmed configuration has an incorrect table entry	Verify configuration matches installation
	n (n>0)	Table comparison (Bus Terminal n)	Incorrect table entry
3	0	Bus command error	No bus terminal installed, or an installed bus terminal is defective and interfering with bus operation
4	0	Bus data error, break behind bus coupler	Verify installation of bus terminals
	n	Break behind Bus Terminal n	Verify installation of bus end terminal
5	n	Bus error in register communication with Bus Terminal n	Replace the nth bus terminal
6	0	Error at initialization	Replace bus coupler
	1	Internal data error	Perform a power cycle on bus coupler
	2	DIP switch changed after software reset	Perform a power cycle on bus coupler
	4	DIP switch incorrect for BootP	Set switches 1 through 8 to OFF if BootP is desired
	8	Internal data error	Perform a power cycle on bus coupler
	16	Error in IP socket	Perform a power cycle on bus coupler
14	n	nth bus terminal has wrong format	Restart bus coupler, and replace unit if error is still present
15	n	Number of bus terminals is no longer correct	Restart bus coupler, and perform configuration with ProtosX Configuration Software if error is still present
16	n	Length of bus data is no longer correct	Restart bus coupler, and perform configuration with ProtosX Configuration Software if error is still present