

ANALOG I/O SPECIFICATIONS



CHAPTER 3

In This Chapter...

Analog I/O Modules Overview.....	3-2
Analog I/O Modules.....	3-3
P3-04ADS Isolated Analog Input.....	3-4
P3-08AD Analog Input.....	3-10
P3-16AD-1 Analog Input.....	3-15
P3-16AD-2 Analog Input.....	3-20
P3-08RTD Analog Input.....	3-25
P3-08THM Analog Input.....	3-30
P3-04DA Analog Output.....	3-35
P3-08DA-1 Analog Output.....	3-41
P3-08DA-2 Analog Output.....	3-46
P3-06DAS-1 Isolated Analog Output (Retired).....	3-51
P3-06DAS-2 Isolated Analog Output (Retired).....	3-56
P3-16DA-1 Analog Output.....	3-61
P3-16DA-2 Analog Output.....	3-66
P3-8AD4DA-1 Analog Input/Output.....	3-71
P3-8AD4DA-2 Analog Input/Output.....	3-77

Analog I/O Modules Overview

A variety of analog I/O modules are available for use in local, expansion, and remote I/O bases.

Each I/O module is identified as an “Input”, “Output”, or “Input/Output” module on its front panel using the color coding scheme listed below. See Chapter 2 for discrete I/O module specifications, Chapter 4 for specialty module specifications and Chapter 5 for valuable system installation and wiring information. The following pages contain the analog I/O module specifications.

There are fifteen analog I/O modules available. The specifications and wiring diagrams, along with configuration and scaling information are in this chapter.

Use the hardware configuration tool in the Productivity Suite programming software to set up the I/O modules. See the Productivity Suite help file.

Analog Input Modules

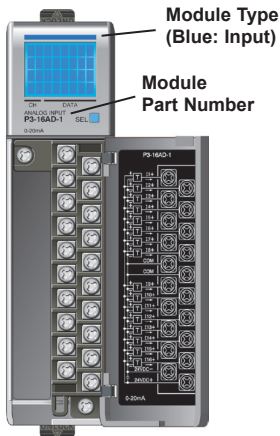

Analog Output Modules

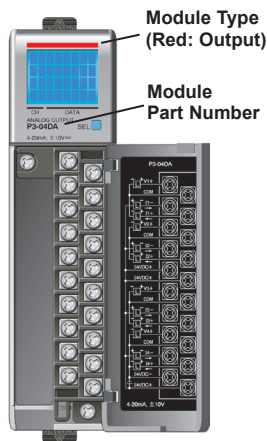

Analog Input/Output Modules

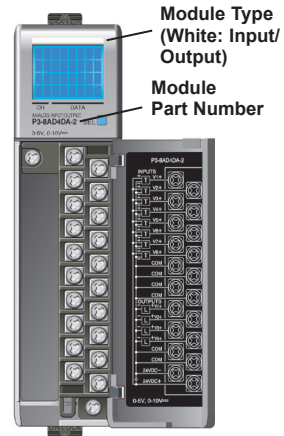

Analog I/O Modules

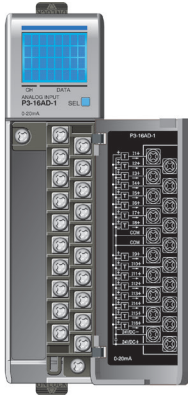

Analog Input Modules

Productivity3000 Analog Input Modules			
Part Number	Number of Channels	Description	See Page
P3-04ADS	4	Isolated Analog Input	3-4
P3-08AD	8	Analog Input	3-10
P3-16AD-1	16	Analog Input (Current)	3-15
P3-16AD-2	16	Analog Input (Voltage)	3-20
P3-08RTD	8	Analog RTD Input	3-25
P3-08THM	8	Analog Thermocouple Input	3-30

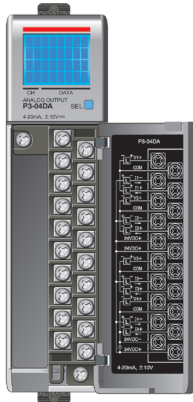

Analog Output Modules

Productivity3000 Analog Output Modules			
Part Number	Number of Channels	Description	See Page
P3-04DA	4	Analog Output	3-35
P3-08DA-1	8	Analog Output (Current)	3-41
P3-08DA-2	8	Analog Output (Voltage)	3-46
P3-06DAS-1	6	Isolated Analog Output (Current)	3-51
P3-06DAS-2	6	Isolated Analog Output (Voltage)	3-56
P3-16DA-1	16	Analog Output (Current)	3-61
P3-16DA-2	16	Analog Output (Voltage)	3-66



Analog Input/Output Modules

Productivity3000 Analog Input/Output Modules			
Part Number	Number of Channels	Description	See Page
P3-8AD4DA-1	8/4	Analog Input/Output (Current)	3-71
P3-8AD4DA-2	8/4	Analog Input/Output (Voltage)	3-77

P3-04ADS Isolated Analog Input

The P3-04ADS Isolated Voltage/Current Analog Input Module provides four isolated channels for receiving $\pm 10\text{VDC}$, 0 to 5VDC, 0 to 10VDC and 0 to 20mA signals.

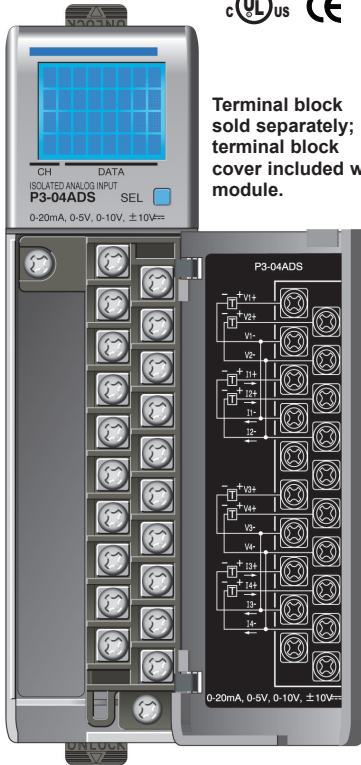

General Specifications

Operating Temperature	0° to 60°C (32° to 140°F),
Storage Temperature	-20° to 70°C (-4° to 158°F)
Humidity	5 to 95% (non-condensing)
Environmental Air	No corrosive gases permitted
Vibration	IEC60068-2-6 (Test Fc)
Shock	IEC60068-2-27 (Test Ea)
Field to Logic Side Isolation	1800VAC applied for 1s
Insulation Resistance	>10MΩ @ 500VDC
Heat Dissipation	2.6 W
Enclosure Type	Open equipment
Module Keying to Backplane	Electronic
Module Location	Any I/O slot in any local, expansion, or remote base in a Productivity3000® system.
Field Wiring	Removable terminal block (not included). Use ZIPLink wiring system or optional terminal block. See Chapter 5.
Terminal Type (not included)	20-position removable terminal block
Weight	61g (2.14 oz)
Agency Approvals	UL508 file E157382, Canada & USA UL1604 file E200031, Canada & USA CE (EN61131-2*) This equipment is suitable for use in Class 1, Division 2, Groups A, B, C and D or non-hazardous locations only.

*Meets EMC and Safety requirements. See the Declaration of Conformity for details.

WARNING: Explosion hazard – Substitution of components may impair suitability for Class I, Division 2.

We recommend using prewired ZIPLink cables and connection modules. See Chapter 5. Terminal block cover included. If you wish to hand-wire your module, a removable terminal block is sold separately. Order part number P3-RTB.



P3-04ADS Isolated Analog Input (continued)

Input Specifications									
Input Channels	4 Channel-to-Channel Isolated								
Module Signal Input Ranges*	± 10 VDC, 0–5 VDC, 0–10 VDC, 0–20 mA								
Resolution	15 bit + sign (0–10 V), 16-bit (all others)								
Value of LSB (least significant bit)	<table border="0"> <tr> <td>± 10V</td> <td>= 305μV</td> </tr> <tr> <td>0–5 V</td> <td>= 152μV</td> </tr> <tr> <td>0–10 V</td> <td>= 305μV</td> </tr> <tr> <td>0–20mA</td> <td>= 0.610μA</td> </tr> </table>	± 10 V	= 305 μ V	0–5 V	= 152 μ V	0–10 V	= 305 μ V	0–20mA	= 0.610 μ A
± 10 V	= 305 μ V								
0–5 V	= 152 μ V								
0–10 V	= 305 μ V								
0–20mA	= 0.610 μ A								
Data Range	0 to 65535 counts unipolar -32768 to +32767 counts bipolar								
Isolated Loop Pwr for Ext. Xmitters	20–30 VDC, current limited to < 30mA								
Input Type	Differential								
Common Mode Rejection Ratio	-75dB min. @ DC, -500kHz								
Maximum Continuous Overload	± 31 mA, current input ± 100 V, voltage input								
Input Impedance	250k Ω $\pm 5\%$ voltage input 250 Ω $\pm 0.1\%$ ¼ W. current input								
Filter Characteristics	Active low pass, -3dB @ 30Hz, -10dB @ 55Hz								
Sample Duration Time	1.28 ms per channel (does not include ladder scan time)								
All Channel Update Rate	5.2 ms								
Open Circuit Detection Time	Zero reading within 1s								
Conversion Method	Successive Approximation								
Accuracy vs. Temperature	± 25 PPM / °C max								
Maximum Inaccuracy	0.1% of range voltage, 0.2% of range current (including temperature drift)								
Linearity Error (End to End)	$\pm 0.025\%$ of range maximum, Monotonic with no missing codes								
Input Stability and Repeatability	$\pm 0.02\%$ of range maximum after 10 min.								
Full Scale Calibration Error (not including Offset)	$\pm 0.05\%$ of range maximum								
Offset Calibration Error	$\pm 0.05\%$ of range maximum								
Max Crosstalk	-96dB 1 LSB								
Channel to Channel Isolation	900VDC applied for 1s								
Recommended Fuse (external)	Edison S500-32-R, 0.032A fuse on current inputs only								
External DC Power Required	NONE for the module								

* Select any two ranges via hardware jumpers. Range setting is for channels 1 and 3; and channels 2 and 4.

Removable Terminal Block Specifications	
Number of Positions	20 screw terminals
Wire Range	22–14 AWG (0.324 to 2.08 sq. mm) Solid / stranded conductor 3/64 in. (1.2 mm) insulation maximum USE COPPER CONDUCTORS , 60°C or equivalent.
Screw Driver Width	1/4 inch (6.5 mm) maximum
Screw Size	M3 size
Screw Torque	Field terminals: 7–9 in./lb (0.882–1.02 N·m) Self-jacking screws: 2.7–3.6 in./lb (0.3–0.4 N·m). Do not over-tighten screws when installing terminal block.

P3-04ADS Isolated Analog Input (continued)

Wiring Diagrams

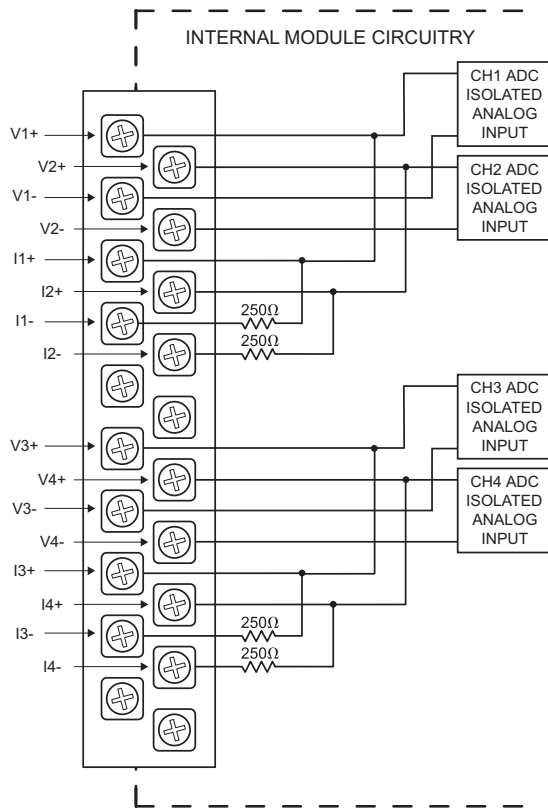

Current Input Circuits

An Edison S500-32-R 0.032A fast-acting fuse is recommended for all 4-20mA current loops.

Unused Circuits

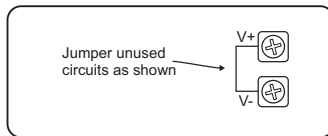

Voltage Input Circuits

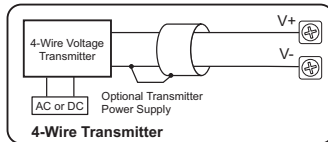

NOTES:

1. Shield connected to signal source common.
2. If current is chosen, I- **MUST** be jumpered to V-. For example, when using 4-20 mA source for Input 3, I3- must be connected to V3-.

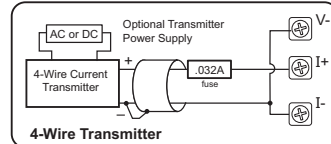
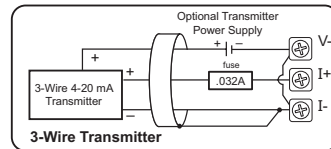
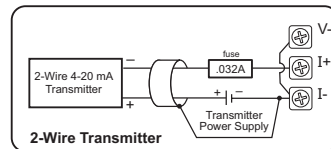

P3-04ADS Isolated Analog Input (continued)

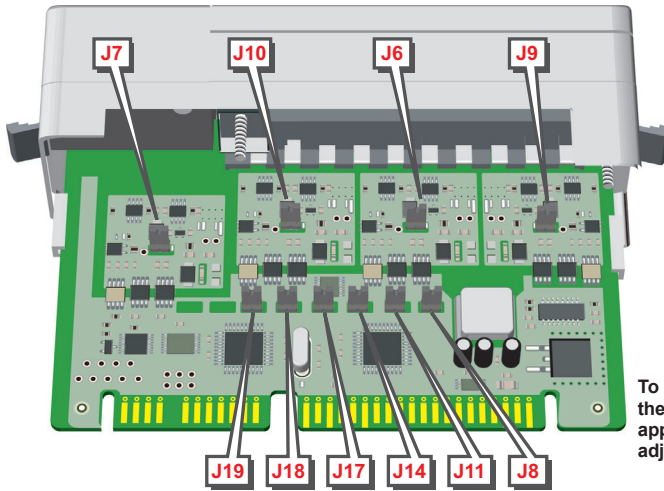

To change the configuration of the P3-04ADS module, select the appropriate jumper position from the adjacent Jumper Orientation Table.

P3-04ADS Jumper Orientation										
J19	J18	J17	J14	J11	J8	J7	J10	J6	J9	Function
N	N	-	-	-	-	-	-	-	-	Enable channel 1
Y	N	-	-	-	-	-	-	-	-	Enable channel 1 & 2
N	Y	-	-	-	-	-	-	-	-	Enable channel 1, 2 & 3
Y	Y	-	-	-	-	-	-	-	-	Enable all channels
-	-	N	N	-	-	Y	-	Y	-	Range 0-5V for channels 1 & 3
-	-	Y	N	-	-	N	-	N	-	Range 0-10V for channels 1 & 3
-	-	N	Y	-	-	N	-	N	-	Range +/-10V for channels 1 & 3
-	-	Y	Y	-	-	Y	-	Y	-	Range 0-20mA for channels 1 & 3
-	-	-	-	N	N	-	Y	-	Y	Range 0-5V for channels 2 & 4
-	-	-	-	Y	N	-	N	-	N	Range 0-10V for channels 2 & 4
-	-	-	-	N	Y	-	N	-	N	Range +/-10V for channels 2 & 4
-	-	-	-	Y	Y	-	Y	-	Y	Range 0-20mA for channels 2 & 4

Legend: N = No jumper installed (open)
Y = Jumper installed

Configuration/Diagnostic Settings	
Number of Channels to Scan	Hardware jumpers per module
Range Selection	Hardware jumpers
Input Under Range Status Bits	1 bit per channel
Output Over Range Status Bits	1 bit per channel
Module Diagnostics Failure	1 bit per module

P3-04ADS Isolated Analog Input (continued)

Module Configuration

Using the Hardware Configuration tool in the Productivity Suite programming software, drag and drop the P3-04ADS module into the base configuration.

Select *Automatic Module Verification* or *No Verification and Enable Hot Swap*. If desired, assign a *User Tagname* to each input point (channel) selected and to each *Status Bit Item*.

4 Channel Isolated 16 Bit Sink Inputs

Automatic Module Verification

No Verification and Enable Hot Swap

Point	User Tagname
1	AIS32-0.2.10.1
2	AIS32-0.2.10.2
3	AIS32-0.2.10.3
4	AIS32-0.2.10.4

Status Bit Item	User Tagname
Module Failed	MST-0.2.10.25
Under Range (ch1)	MST-0.2.10.57
Under Range (ch2)	MST-0.2.10.58
Under Range (ch3)	MST-0.2.10.59
Under Range (ch4)	MST-0.2.10.60
Over Range (ch1)	MST-0.2.10.89
Over Range (ch2)	MST-0.2.10.90
Over Range (ch3)	MST-0.2.10.91

Module Configuration Comments

Monitor Module Info OK Cancel Help

P3-04ADS Isolated Analog Input (continued)

LCD Panel Display

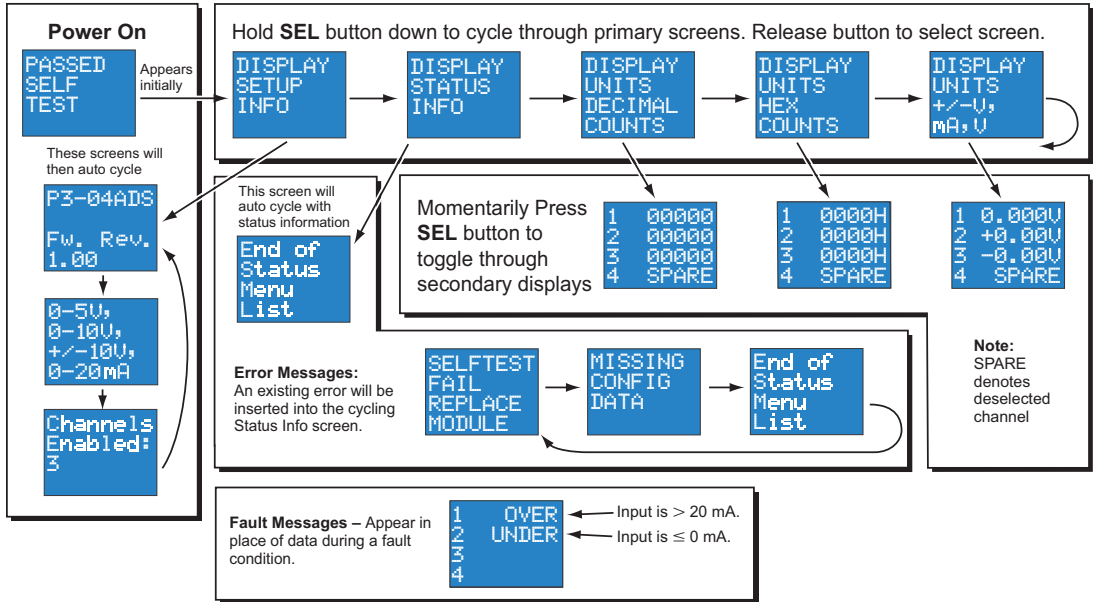

P3-08AD Analog Input

The P3-08AD Voltage/Current Analog Input Module provides 8 channels for receiving $\pm 10\text{VDC}$, $\pm 5\text{VDC}$, 0 to 5VDC, 0 to 10VDC, and 0 to 20mA signals.

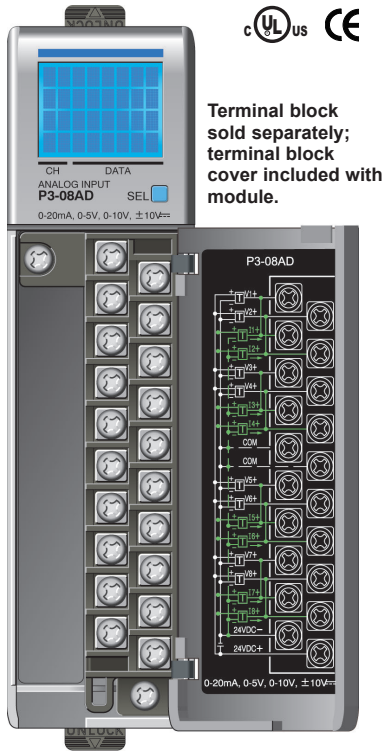

Terminal block sold separately; terminal block cover included with module.

General Specifications

Operating Temperature	0° to 60°C (32° to 140°F),
Storage Temperature	-20° to 70°C (-4° to 158°F)
Humidity	5 to 95% (non-condensing)
Environmental Air	No corrosive gases permitted
Vibration	IEC60068-2-6 (Test Fc)
Shock	IEC60068-2-27 (Test Ea)
Field to Logic Side Isolation	1800VAC applied for 1s
Insulation Resistance	>10M Ω @ 500VDC
Heat Dissipation	1.1 W
Enclosure Type	Open equipment
Module Keying to Backplane	Electronic
Module Location	Any I/O slot in any local, expansion, or remote base in a Productivity3000® system.
Field Wiring	Removable terminal block (not included). Use ZIPLink wiring system or optional terminal block. See Chapter 5.
Terminal Type (not included)	20-position removable terminal block
Weight	105g (3.73 oz)
Agency Approvals	UL508 file E157382, Canada & USA UL1604 file E200031, Canada & USA CE (EN61131-2*) This equipment is suitable for use in Class 1, Division 2, Groups A, B, C and D or non-hazardous locations only.

*Meets EMC and Safety requirements. See the Declaration of Conformity for details.

WARNING: Explosion hazard – Substitution of components may impair suitability for Class 1, Division 2.

We recommend using prewired ZIPLink cables and connection modules. See Chapter 5.

Terminal block cover included. If you wish to hand-wire your module, a removable terminal block is sold separately. Order part number P3-RTB.



P3-08AD Analog Input (continued)

Input Specifications	
Input Channels	8
Module Signal Input Ranges	$\pm 10\text{VDC}$, $\pm 5\text{VDC}$, $0 - 5\text{VDC}$, $0 - 10\text{VDC}$, $0 - 20\text{mA}$
Signal Resolution	16 bit
Resolution Value of LSB (least significant bit)	1 LSB = 1 count $\pm 10\text{V} = 305\mu\text{V}$ $\pm 5\text{V} = 152\mu\text{V}$ $0 - 5\text{V} = 76\mu\text{V}$ $0 - 10\text{V} = 152\mu\text{V}$ $0 - 20\text{mA} = 0.305\mu\text{A}$
Data Range	0 to 65535 counts unipolar -32768 to +32767 counts bipolar
Maximum Continuous Overload	$\pm 31\text{mA}$, current input $\pm 100\text{V}$, voltage input
Input Impedance	$1\text{M}\Omega \pm 10\%$ voltage input $250\Omega \pm 0.1\%$, $1/4\text{ W}$ current input
Hardware Filter Characteristics	Low pass 1st order, $-3\text{dB}@48\text{Hz}$
Sample Duration Time	$455\mu\text{s}$ per channel (does not include ladder scan time)
All Channel Update Rate	4ms
Open Circuit Detection Time	Zero reading within 1s (current input only)
Conversion Method	Successive Approximation
Accuracy vs. Temperature	$\pm 10\text{PPM} / ^\circ\text{C}$ Maximum
Maximum Inaccuracy	0.1% of range voltage, 0.2% of range current (including temperature drift)
Linearity Error (end to end)	$\pm 0.01\%$ of range max., $\pm 10\text{V}$ & $\pm 5\text{V}$ $\pm 0.015\%$ of range max., $0-10\text{ V}$, $0-5\text{ V}$ & $0-20\text{ mA}$ Monotonic with no missing codes
Input Stability and Repeatability	$\pm 0.035\%$ of range (after 10 min. warmup)
Full Scale Calibration Error (not including offset)	$\pm 0.1\%$ of range maximum
Offset Calibration Error	$\pm .065\%$ of range maximum
Max Crosstalk	-96dB
Recommended Fuse (external)	Edison S500-32-R, .032A fuse on current inputs only
External DC Power Required	24VDC (-20% / $+ 25\%$) 33mA

Removable Terminal Block Specifications	
Number of Positions	20 screw terminals
Wire Range	22–14 AWG (0.324 to 2.08 sq. mm) Solid / stranded conductor 3/64 in. (1.2 mm) insulation maximum USE COPPER CONDUCTORS , 60°C or equivalent.
Screw Driver Width	1/4 inch (6.5 mm) maximum
Screw Size	M3 size
Screw Torque	Field terminals: 7–9 in./lb (0.882–1.02 N·m) Self-jacking screws: 2.7–3.6 in./lb (0.3–0.4 N·m). Do not over-tighten screws when installing terminal block.

P3-08AD Analog Input (continued)

Wiring Diagrams

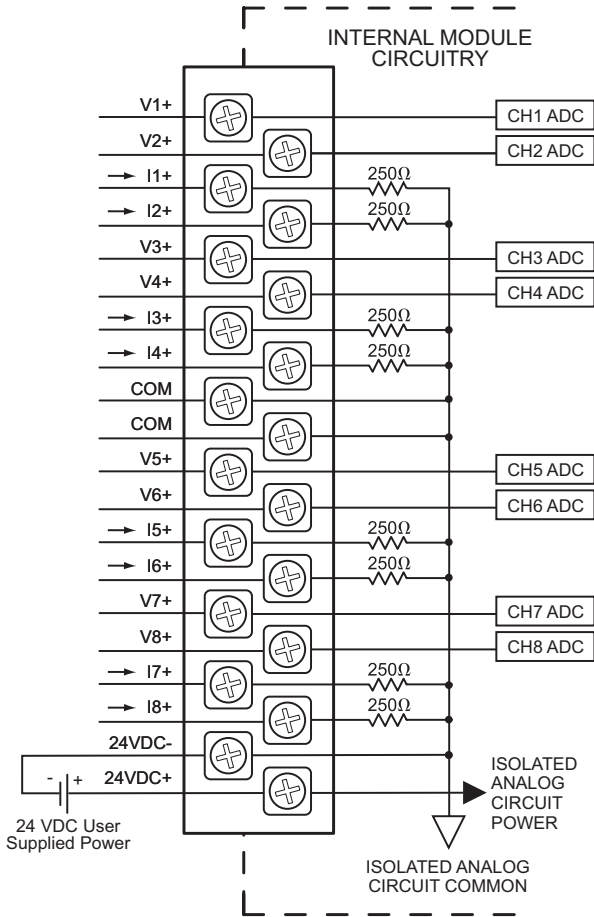

Current Sinking Input Circuits

An Edison S500-32-R 0.032A fast-acting fuse is recommended for all current loops.

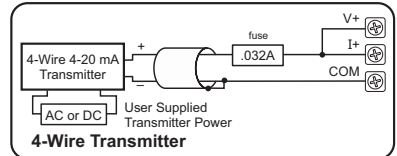
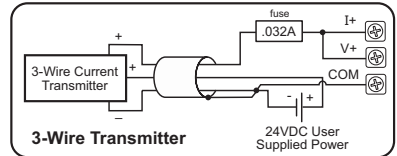
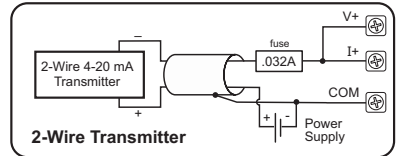

Voltage Input Circuits

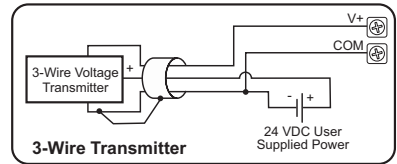
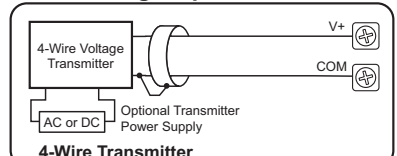

P3-08AD Analog Input (continued)

Module Configuration

Using the Hardware Configuration tool in the Productivity Suite programming software, drag and drop the P3-08AD module into the base configuration.

Select *Automatic Module Verification* or *No Verification and Enable Hot Swap*. Select *Range* type for each input. If desired, assign a *User Tagname* to each input point (channel) selected and to each *Status Bit Item*.

P3-08AD

8 Channel 16 Bit Voltage & Current Sinking Input

Automatic Module Verification
 No Verification and Enable Hot Swap

Point	User Tagname	Ch. Select		Range
		All		
1	AIS32-0.2.11.1	<input checked="" type="checkbox"/>	<input type="checkbox"/>	0-20 ma
2	AIS32-0.2.11.2	<input checked="" type="checkbox"/>	<input type="checkbox"/>	0-20 ma
3	AIS32-0.2.11.3	<input checked="" type="checkbox"/>	<input type="checkbox"/>	0-20 ma
4	AIS32-0.2.11.4	<input checked="" type="checkbox"/>	<input type="checkbox"/>	0-20 ma
5	AIS32-0.2.11.5	<input checked="" type="checkbox"/>	<input type="checkbox"/>	0-20 ma
6	AIS32-0.2.11.6	<input checked="" type="checkbox"/>	<input type="checkbox"/>	0-20 ma
7	AIS32-0.2.11.7	<input checked="" type="checkbox"/>	<input type="checkbox"/>	0-20 ma

Status Bit Item	User Tagname
Module Failed	MST-0.2.11.25
Missing 24V	MST-0.2.11.26
Under Range Error (ch1)	MST-0.2.11.57
Under Range Error (ch2)	MST-0.2.11.58
Under Range Error (ch3)	MST-0.2.11.59
Under Range Error (ch4)	MST-0.2.11.60
Under Range Error (ch5)	MST-0.2.11.61
Under Range Error (ch6)	MST-0.2.11.62

P3-08AD Analog Input (continued)

LCD Panel Display

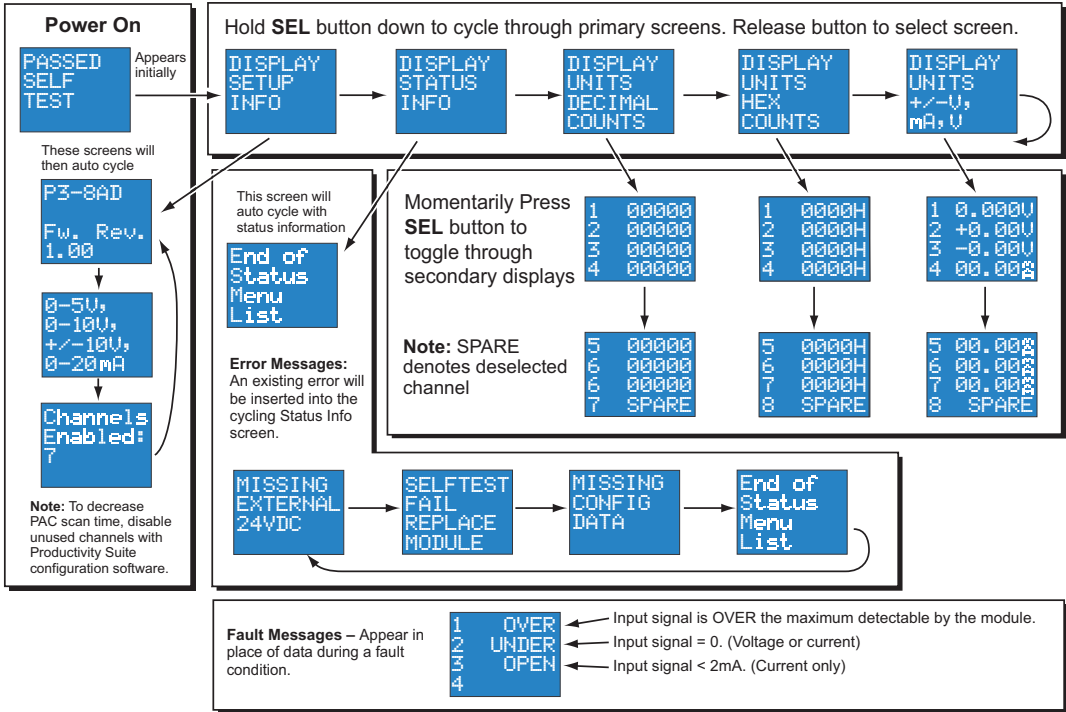

P3-16AD-1 Analog Input

The P3-16AD-1 Current Analog Input Module provides sixteen channels for receiving 0 to 20mA input signals.

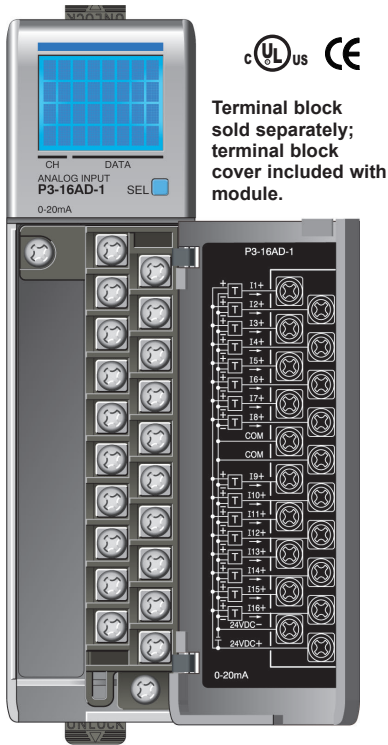

Terminal block sold separately; terminal block cover included with module.

Input Specifications

Input Channels	16 sinking
Module Signal Input Range	0–20 mA
Signal Resolution	16 bit
Resolution Value of LSB (least significant bit)	0–20 mA = 0.305e-9 A per count; nA/ct (1 LSB = 1 count)
Data Range	0-65535 counts
Input Type	Single-ended (1 common)
Maximum Continuous Overload	±31mA
Input Impedance	250Ω ±0.1% ¼W
Filter Characteristics	Low Pass, -3dB @ 100Hz
Sample Duration Time	7ms per channel (ladder scan time not included)
All Channel Update Rate	112ms
Open Circuit Detection Time	Zero reading within 1s
Conversion Method	Successive approximation
Accuracy vs. Temperature	±25PPM / °C maximum
Maximum Inaccuracy	0.1% of range (including temperature drift)
Linearity Error (end to end)	±10 LSB maximum (±0.015% of range) Monotonic with no missing codes
Input Stability and Repeatability	±10 LSB
Full Scale Calibration Error (not including offset)	±10 LSB maximum (±0.015% of range)
Offset Calibration Error	±10 LSB maximum
Max Crosstalk	-76dB, ±10 LSB
Recommended Fuse (external)	Edison S500-32-R, 0.032A fuse
External DC Power Required	24VDC (-20% / +25%), 20mA

Removable Terminal Block Specifications

Number of Positions	20 screw terminals
Wire Range	22–14 AWG (0.324 to 2.08 sq. mm) Solid / stranded conductor 3/64 in. (1.2 mm) insulation maximum USE COPPER CONDUCTORS , 60°C or equivalent.
Screw Driver Width	1/4 inch (6.5 mm) maximum
Screw Size	M3 size
Screw Torque	Field terminals: 7–9 in./lb (0.882–1.02 N-m) Self-jacking screws: 2.7–3.6 in./lb (0.3–0.4 N-m). Do not over-tighten screws when installing terminal block.

We recommend using prewired ZIPLink cables and connection modules. See Chapter 5.

Terminal block cover included. If you wish to hand-wire your module, a removable terminal block is sold separately. Order part number P3-RTB.



P3-16AD-1 Analog Input (continued)

General Specifications	
Operating Temperature	0° to 60°C (32° to 140°F),
Storage Temperature	-20° to 70°C (-4° to 158°F)
Humidity	5 to 95% (non-condensing)
Environmental Air	No corrosive gases permitted
Vibration	IEC60068-2-6 (Test Fc)
Shock	IEC60068-2-27 (Test Ea)
Field to Logic Side Isolation	1800VAC applied for 1s
Insulation Resistance	>10MΩ @ 500VDC
Heat Dissipation	2.1 W
Enclosure Type	Open equipment
Module Keying to Backplane	Electronic
Module Location	Any I/O slot in any local, expansion, or remote base in a Productivity3000® system.
Field Wiring	Removable terminal block (not included). Use ZIP Link wiring system or optional terminal block. See Chapter 5.
Terminal Type (not included)	20-position removable terminal block
Weight	105g (3.73 oz)
Agency Approvals	UL508 file E157382, Canada & USA UL1604 file E200031, Canada & USA CE (EN61131-2*) This equipment is suitable for use in Class 1, Division 2, Groups A, B, C and D or non-hazardous locations only.

*Meets EMC and Safety requirements. See the Declaration of Conformity for details.

WARNING: Explosion hazard – Substitution of components may impair suitability for Class I, Division 2.

P3-16AD-1 Analog Input (continued)

Wiring Diagrams

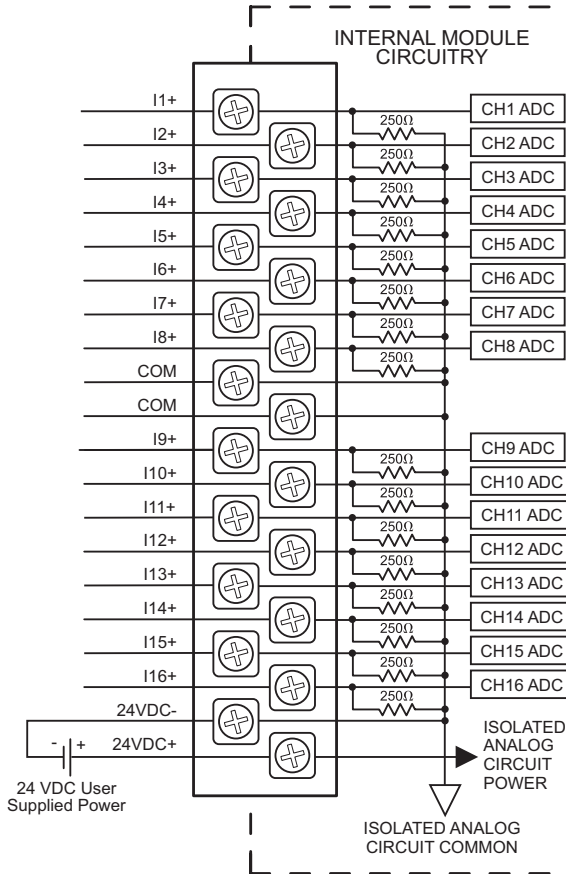

Current Input Circuits

An Edison S500-32-R 0.032A fast-acting fuse is recommended for current loops.

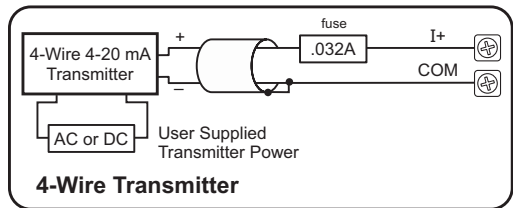
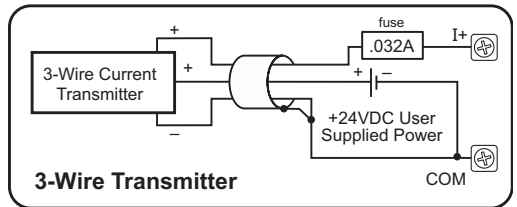
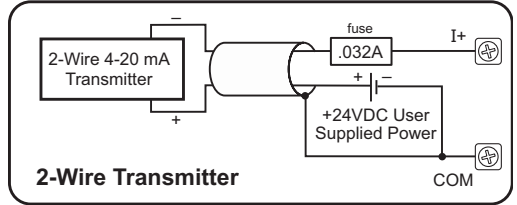

Note: Do not connect both ends of shield.

P3-16AD-1 Analog Input (continued)

Module Configuration

Using the Hardware Configuration tool in the Productivity Suite programming software, drag and drop the P3-16AD-1 module into the base configuration.

Select *Automatic Module Verification* or *No Verification and Enable Hot Swap*. If desired, assign a *User Tagname* to each input point (channel) selected and to each *Status Bit Item*.

Automatic Module Verification
 No Verification and Enable Hot Swap

Point	User Tagname	Ch. Select
		All <input checked="" type="checkbox"/>
1	AI532-0.1.1.1	<input checked="" type="checkbox"/>
2	AI532-0.1.1.2	<input checked="" type="checkbox"/>
3	AI532-0.1.1.3	<input checked="" type="checkbox"/>
4	AI532-0.1.1.4	<input checked="" type="checkbox"/>
5	AI532-0.1.1.5	<input checked="" type="checkbox"/>
6	AI532-0.1.1.6	<input checked="" type="checkbox"/>
7	AI532-0.1.1.7	<input checked="" type="checkbox"/>
8	AI532-0.1.1.8	<input checked="" type="checkbox"/>
9	AI532-0.1.1.9	<input checked="" type="checkbox"/>

Status Bit Item	User Tagname
Module Failed	MST-0.1.1.25
Missing 24V	MST-0.1.1.26
Under Range Error (ch1)	MST-0.1.1.57
Under Range Error (ch2)	MST-0.1.1.58
Under Range Error (ch3)	MST-0.1.1.59
Under Range Error (ch4)	MST-0.1.1.60
Under Range Error (ch5)	MST-0.1.1.61
Under Range Error (ch6)	MST-0.1.1.62
Under Range Error (ch7)	MST-0.1.1.63
Under Range Error (ch8)	MST-0.1.1.64

P3-16AD-1 Analog Input (continued)

LCD Panel Display

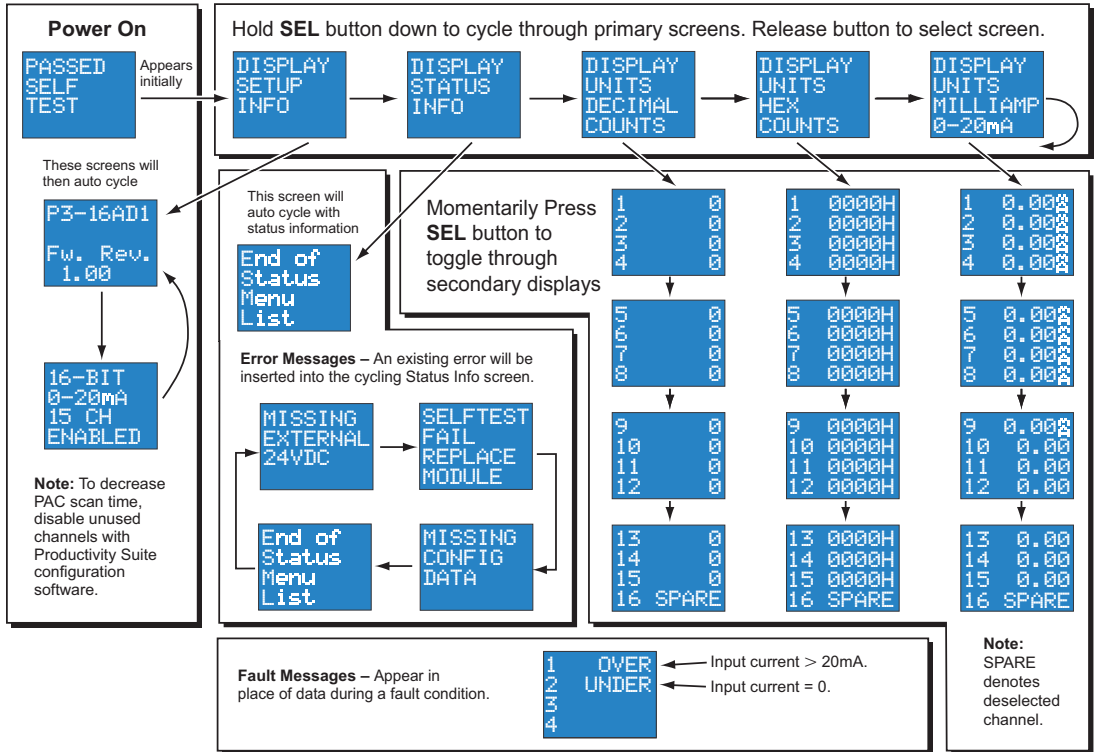

P3-16AD-2 Analog Input

The P3-16AD-2 Voltage Analog Input Module provides sixteen channels for receiving 0 to 10 VDC signals.

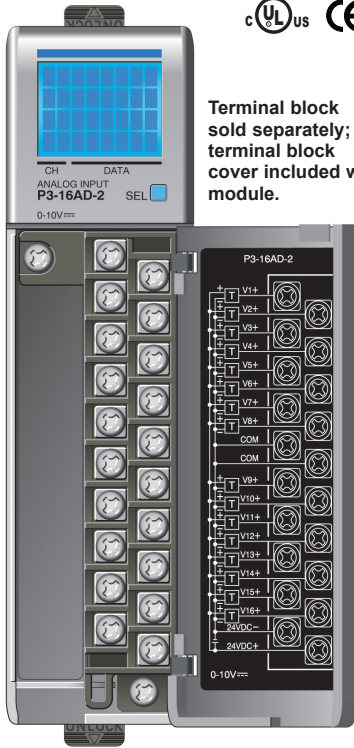

Terminal block sold separately; terminal block cover included with module.



Input Specifications	
Input Channels	16
Module Signal Input Range	0–10 VDC
Signal Resolution	16 bit
Resolution Value of LSB (least significant bit)	0–10 VDC = 152µV per count (1 LSB = 1 count)
Data Range	0 to 65535 counts
Input Type	Single-ended (one common)
Maximum Continuous Overload	±100V
Input Impedance	250kΩ (typical)
Filter Characteristics	Low Pass, -3dB @ 100Hz
Sample Duration Time	7ms per channel (ladder scan time not included)
All Channel Update Rate	112ms
Open Circuit Detection Time	Zero reading within 1s
Conversion Method	Successive approximation
Accuracy vs. Temperature	±25PPM / °C maximum
Maximum Inaccuracy	0.1% of range (including temperature drift)
Linearity Error (end to end)	±10 LSB maximum (±0.015% of range) Monotonic with no missing codes
Input Stability and Repeatability	±10 LSB
Full Scale Calibration Error (not including offset)	±10 LSB maximum (±0.015% of range)
Offset Calibration Error	±10 LSB maximum
Max Crosstalk	-76dB, 10 LSB
External DC Power Required	24VDC (-20% / +25%), 41mA maximum

Removable Terminal Block Specifications	
Number of Positions	20 screw terminals
Wire Range	22–14 AWG (0.324 to 2.08 sq. mm) Solid / stranded conductor 3/64 in. (1.2 mm) insulation maximum USE COPPER CONDUCTORS , 60°C or equivalent.
Screw Driver Width	1/4 inch (6.5 mm) maximum
Screw Size	M3 size
Screw Torque	Field terminals: 7–9 in./lb (0.882–1.02 N·m) Self-jacking screws: 2.7–3.6 in./lb (0.3–0.4 N·m). Do not over-tighten screws when installing terminal block.

We recommend using prewired ZIPLink cables and connection modules. See Chapter 5.

Terminal block cover included. If you wish to hand-wire your module, a removable terminal block is sold separately. Order part number P3-RTB.



P3-16AD-2 Analog Input (continued)

General Specifications	
Operating Temperature	0° to 60°C (32° to 140°F),
Storage Temperature	-20° to 70°C (-4° to 158°F)
Humidity	5 to 95% (non-condensing)
Environmental Air	No corrosive gases permitted
Vibration	IEC60068-2-6 (Test Fc)
Shock	IEC60068-2-27 (Test Ea)
Field to Logic Side Isolation	1800 VAC applied for 1s
Insulation Resistance	>10MΩ @ 500 VDC
Heat Dissipation	1.4 W
Enclosure Type	Open equipment
Module Keying to Backplane	Electronic
Module Location	Any I/O slot in any local, expansion, or remote base in a Productivity3000® system.
Field Wiring	Removable terminal block (not included). Use ZIPLink wiring system or optional terminal block. See Chapter 5.
Terminal Type (not included)	20-position removable terminal block
Weight	105g (3.73 oz)
Agency Approvals	UL508 file E157382, Canada & USA UL1604 file E200031, Canada & USA CE (EN61131-2*) This equipment is suitable for use in Class 1, Division 2, Groups A, B, C and D or non-hazardous locations only.

*Meets EMC and Safety requirements. See the Declaration of Conformity for details.

WARNING: Explosion hazard – Substitution of components may impair suitability for Class 1, Division 2.

P3-16AD-2 Analog Input (continued)

Wiring Diagrams

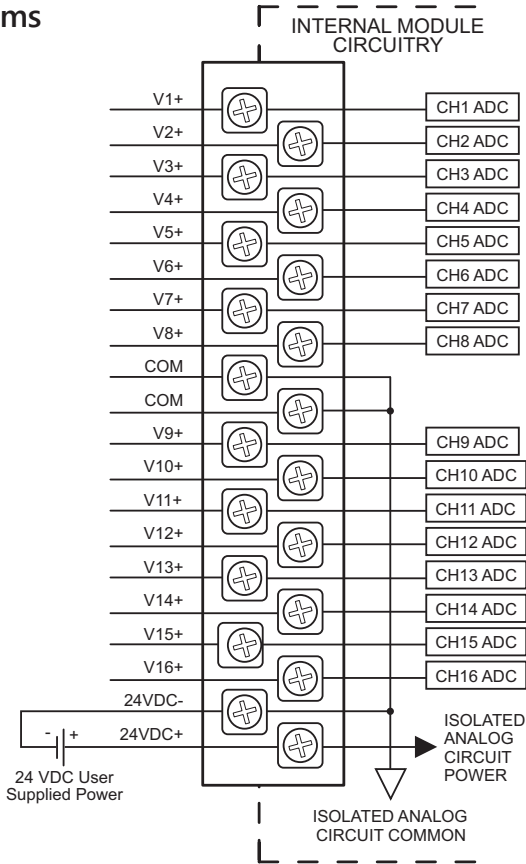

Voltage Input Circuits

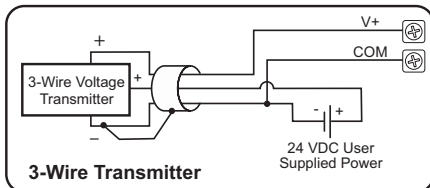
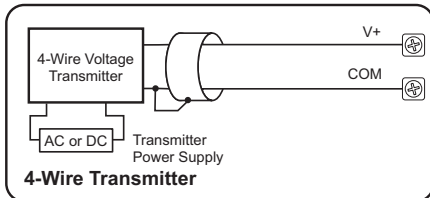

Notes for maximum accuracy:
1. Jumper unused inputs to common.

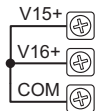

P3-16AD-2 Analog Input (continued)

Module Configuration

Using the Hardware Configuration tool in the Productivity Suite programming software, drag and drop the P3-16AD-2 module into the base configuration.

Select *Automatic Module Verification* or *No Verification and Enable Hot Swap*. If desired, assign a *User Tagname* to each input point (channel) selected and to each *Status Bit Item*.

P3-1

Qty. 16 Channel 14 Bit Voltage Sink Inputs

Automatic Module Verification
 No Verification and Enable Hot Swap

Point	User Tagname	Ch. Select
1	AIS32-0.1.1.1	All <input checked="" type="checkbox"/>
2	AIS32-0.1.1.2	<input checked="" type="checkbox"/>
3	AIS32-0.1.1.3	<input checked="" type="checkbox"/>
4	AIS32-0.1.1.4	<input checked="" type="checkbox"/>
5	AIS32-0.1.1.5	<input checked="" type="checkbox"/>
6	AIS32-0.1.1.6	<input checked="" type="checkbox"/>
7	AIS32-0.1.1.7	<input checked="" type="checkbox"/>
8	AIS32-0.1.1.8	<input checked="" type="checkbox"/>
9	AIS32-0.1.1.9	<input checked="" type="checkbox"/>

Status Bit Item	User Tagname
Module Failed	MST-0.1.1.25
Missing 24V	MST-0.1.1.26
Under Range Error (ch1)	MST-0.1.1.57
Under Range Error (ch2)	MST-0.1.1.58
Under Range Error (ch3)	MST-0.1.1.59
Under Range Error (ch4)	MST-0.1.1.60
Under Range Error (ch5)	MST-0.1.1.61
Under Range Error (ch6)	MST-0.1.1.62
Under Range Error (ch7)	MST-0.1.1.63
Under Range Error (ch8)	MST-0.1.1.64

Monitor Module Info OK Cancel Help

P3-16AD-2 Analog Input (continued)

LCD Panel Display

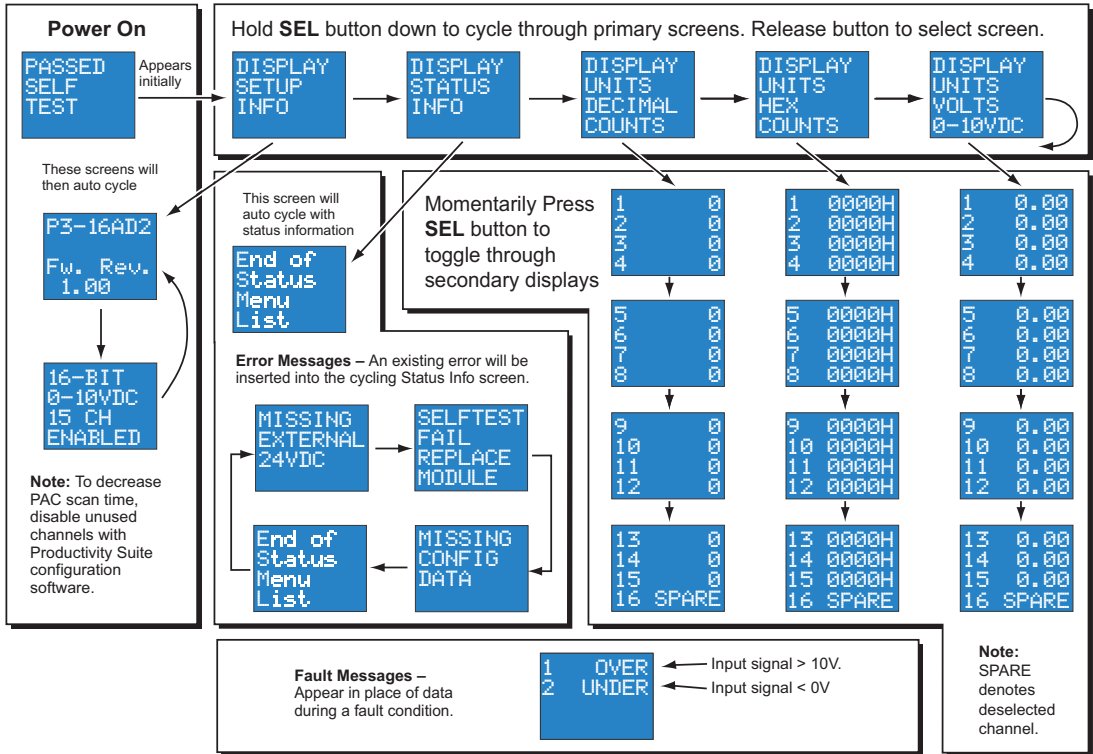

P3-08RTD Analog Input

The P3-08RTD input module provides eight differential channels for receiving RTD and resistance input signals.



Terminal block sold separately; terminal block cover included with module.

RTD Input Specifications	
Input Channels	8 Differential
Max. Common Mode Voltage	5VDC
Data Format	Floating Point
Common Mode Rejection	-90dB min. @ DC, -150dB min. @ 50/60Hz
Absolute Maximum Ratings	Fault protected input, ±50V
Internal Resolution	16 bit, ± 0.1°C or °F (up to 100 Hz filter)
Input Ranges (RTD Types)	Pt100 -200°C/850°C (-328°F/1562°F) Pt1000 -200°C/595°C (-328°F/1103°F) JPt100 -100°C/450°C (-148°F/ 842°F) 10Ω Cu. -200°C/260°C (-328°F/ 500°F) 25Ω Cu. -200°C/260°C (-328°F/ 500°F) 120Ω Ni. -80°C/260°C (-112°F/ 500°F)
RTD Linearization	Automatic
Excitation Current (all ranges)	200µA
Accuracy vs. Temperature	±5ppm per °C (maximum)
Full Scale Calibration	±1°C
Offset Calibration Error	±1 count (negligible)
Linearity Error (end to end)	±0.5°C maximum, ±0.01°C typical, Monotonic with no missing codes
Maximum Inaccuracy	±1°C maximum (excluding RTD error) (including temperature drift)
Warm-up Time	2 minutes for ±0.2% repeatability
Sample Duration (Single channel update rate)	Dependent on Digital Filter Settings -- 488ms @ 10Hz, 88ms @ 50 Hz, 75ms @ 60Hz, 56ms @ 100Hz, 48ms @ 250Hz
Filter Characteristics	Digital filter cutoff frequencies: 10Hz, 50Hz, 60Hz, 100Hz, or 250Hz
All Channel Update Rate	Single channel update rate times the number of enabled channels
Open Circuit Detection Time	Positive full scale reading within 2s
Conversion Method	Sigma-Delta
External DC Power Required	None

Resistance Input Specifications	
Internal Resolution	16 bit, .0015% of full scale range in ohms (up to 100Hz filter)
Resistance Input Ranges and CPU Resolution	0-10,000Ω, Resolution 1Ω 0-6,250Ω, Resolution 0.1 Ω 0-3,125Ω, Resolution 0.1 Ω 0-1,562.5 Ω, Resolution 0.1 Ω 0-781.25 Ω, Resolution 0.1 Ω 0-390.625 Ω, Resolution 0.01 Ω 0-195.3125 Ω, Resolution 0.01 Ω
Accuracy vs. Temperature	±25ppm per °C (maximum)
Full Scale Calibration	±0.02% of full scale range
Offset Calibration Error	±0.0015% of full scale range in ohms
Linearity Error (end to end)	±0.0015% of full scale range maximum at 25°C, Monotonic with no missing codes
Maximum Inaccuracy	±0.10% of full scale range

P3-08RTD Analog Input (continued)

General Specifications	
Operating Temperature	0° to 60°C (32° to 140°F),
Storage Temperature	-20° to 70°C (-4° to 158°F)
Humidity	5 to 95% (non-condensing)
Environmental Air	No corrosive gases permitted
Vibration	IEC60068-2-6 (Test Fc)
Shock	IEC60068-2-27 (Test Ea)
Heat Dissipation	0.33 W
Enclosure Type	Open equipment
Module Keying to Backplane	Electronic
Module Location	Any I/O slot in any local, expansion, or remote base in a Productivity3000® system.
Field Wiring	Removable terminal block (included). The P3-08RTD module is not compatible with the ZIPLink wiring system.
Terminal Type	20-position removable terminal block (included)
Weight	107.8g (3.79 oz)
Agency Approvals	UL508 file E157382, Canada & USA UL1604 file E200031, Canada & USA CE (EN61131-2*) This equipment is suitable for use in Class 1, Division 2, Groups A, B, C and D or non-hazardous locations only.

*Meets EMC and Safety requirements. See the Declaration of Conformity for details.

WARNING: Explosion hazard – Substitution of components may impair suitability for Class I, Division 2.

Removable Terminal Block Specifications	
Number of Positions	20 screw terminals
Wire Range	22–14 AWG (0.324 to 2.08 sq. mm) Solid / stranded conductor 3/64 in. (1.2 mm) insulation maximum USE COPPER CONDUCTORS , 60°C or equivalent.
Screw Driver Width	1/4 inch (6.5 mm) maximum
Screw Size	M3 size
Screw Torque	Field terminals: 7–9 in./lb (0.882–1.02 N·m) Self-jacking screws: 2.7–3.6 in./lb (0.3–0.4 N·m). Do not over-tighten screws when installing terminal block.

Diagnostics	
Module Diagnostics Failure	1 bit per module
Module Not Ready	1 bit per module
Channel Burn-out (RTD only)	1 bit per channel
Under-range (RTD only)	1 bit per channel
Over-range	1 bit per channel

P3-08RTD Analog Input (continued)

Wiring Diagrams

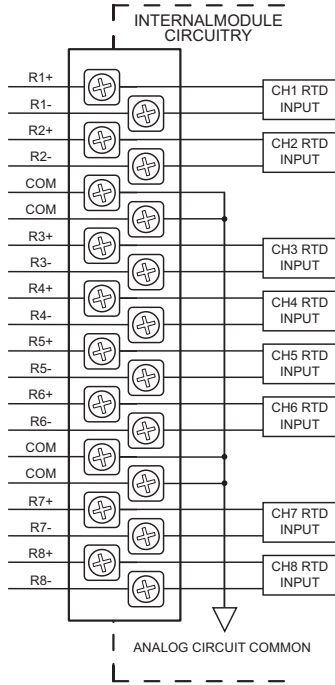

Notes for maximum accuracy:

1. For 2-wire RTD, attach third wire to module common.
2. R+, R-, and COM wires to an RTD must be equal length and type. Refer to RTD manufacturer's recommendations.
3. Do not use cable shield as sensing wire.
4. When applicable, connect shield to RTD common only, otherwise connect to module common only. Do not connect shield at both ends.
5. Jumper unused inputs to common.

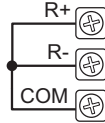

Resistance Input

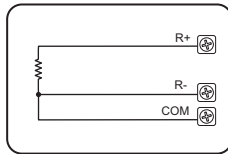

RTD Input Circuits

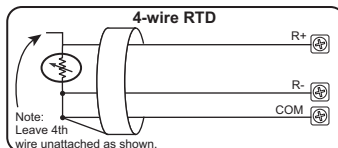
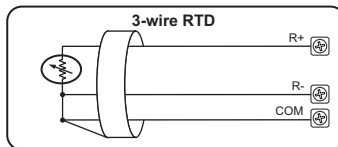
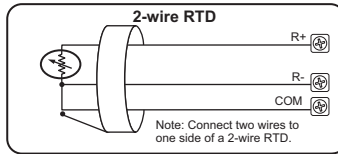

P3-08RTD Analog Input (continued)

Module Configuration

Using the Hardware Configuration tool in the Productivity Suite programming software, drag and drop the P3-08RTD module into the base configuration.

Select *Automatic Module Verification* or *No Verification and Enable Hot Swap*. Then select *Input Range*, *Digital Filter*, *Temperature Scale* and *Burnout Detection*. If desired, assign a *User Tagname* to each input point (channel) selected and to each *Status Bit Item*.

8 Channels 16 Bit Resistance Temperature Device

Automatic Module Verification
 No Verification and Enable Hot Swap

Input Range: PT100

Digital Filter: 75 msec

Temperature Scale: Degrees F

Burnout Detection: Low Side Burnout Detection

Point	User Tagname	Ch. Select	Burnout Error	Under Range Error	Over Range Error
1	AIF32-0.3.3.1	<input checked="" type="checkbox"/>	MST-0.3.3.41	MST-0.3.3.57	MST-0.3.3.89
2	AIF32-0.3.3.2	<input checked="" type="checkbox"/>	MST-0.3.3.42	MST-0.3.3.58	MST-0.3.3.90
3	AIF32-0.3.3.3	<input checked="" type="checkbox"/>	MST-0.3.3.43	MST-0.3.3.59	MST-0.3.3.91
4	AIF32-0.3.3.4	<input checked="" type="checkbox"/>	MST-0.3.3.44	MST-0.3.3.60	MST-0.3.3.92
5	AIF32-0.3.3.5	<input checked="" type="checkbox"/>	MST-0.3.3.45	MST-0.3.3.61	MST-0.3.3.93
6	AIF32-0.3.3.6	<input checked="" type="checkbox"/>	MST-0.3.3.46	MST-0.3.3.62	MST-0.3.3.94
7	AIF32-0.3.3.7	<input checked="" type="checkbox"/>	MST-0.3.3.47	MST-0.3.3.63	MST-0.3.3.95
8	AIF32-0.3.3.8	<input checked="" type="checkbox"/>	MST-0.3.3.48	MST-0.3.3.64	MST-0.3.3.96

Status Bit Item	User Tagname
Module Failed	MST-0.3.3.25
Module Not Ready	MST-0.3.3.27

Monitor Module Info OK Cancel Help

P3-08RTD Analog Input (continued)

LCD Panel Display

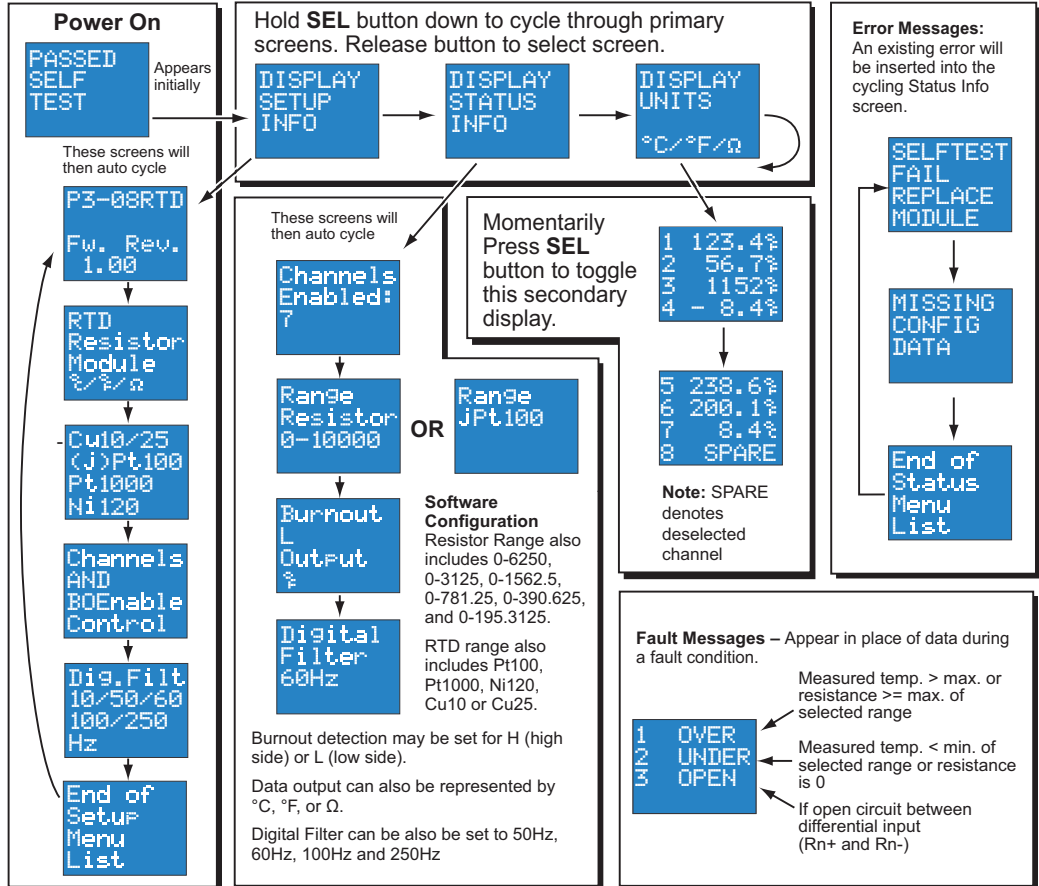

P3-08THM Analog Input

The P3-08THM Thermocouple Input Module provides eight differential channels for receiving thermocouple and voltage input signals.

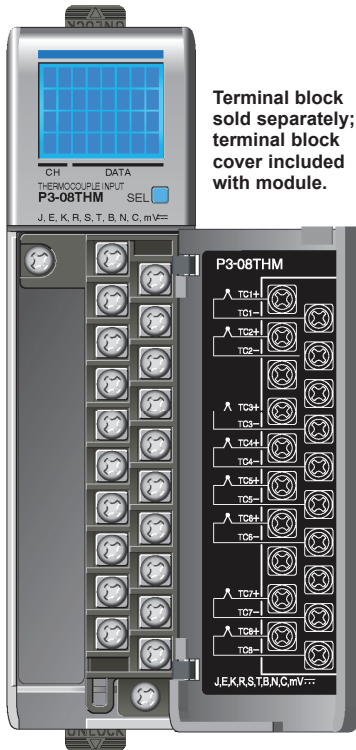

Terminal block sold separately; terminal block cover included with module.

T/C Input Specifications

Input channels	8 differential
CPU Data Format	Floating point
Common Mode Range	±1.25 V
Common Mode Rejection	100dB @ DC and 130dB @ 60Hz
Input Impedance	>5M ohms
Maximum Ratings	Fault-protected inputs to ±50VDC
Resolution	16-bit, ±0.1°C or °F
Thermocouple Input Ranges	Type J -190° to 760°C (-310° to 1400°F); Type E -210° to 1000°C (-346° to 1832°F); Type K -150° to 1372°C (-238° to 2502°F); Type R 65° to 1768°C (149° to 3214°F); Type S 65° to 1768°C (149° to 3214°F); Type T -230° to 400°C (-382° to 752°F); Type B 529° to 1820°C (984° to 3308°F); Type N -70° to 1300°C (-94° to 2372°F); Type C 65° to 2320°C (149° to 4208°F);
Cold Junction Compensation	Automatic
Thermocouple Linearization	Automatic
Accuracy vs. Temperature	±50PPM / °C maximum
Linearity Error	±1°C Maximum (±0.5°C typical), Monotonic with no missing codes
Maximum Inaccuracy	±3°C Max (excluding thermocouple error) (including temperature drift)
Warm-up Time	30 Minutes for ±1°C Repeatability 2 minutes to reach voltage specifications
Sample Duration Time	270ms
All Channel Update Rate	2.16 s
Open Circuit Detection Time	10-15 secs typical, 20 secs max.
Conversion Method	Sigma-Delta
External DC Power	None

Voltage Input Specifications

Linear mV Device Input Ranges	0–39.0625 mVDC, ±39.0625 mVDC, ±78.125 mVDC, 0–156.25 mVDC, ±156.25 mVDC, 0–1250 mVDC
Max Voltage Input Offset Error	0.05% @ 0° -60°C, typical 0.04% @ 25°C
Max Voltage Input Gain Error	0.06% @ 25°C
Max Voltage Input Linearity Error	0.05% @ 0° -60°C, typical 0.03% @ 25°C
Max Voltage Input Inaccuracy	0.2% @ 0° -60°C, typical 0.06% @ 25°C

P3-08THM Analog Input (continued)

General Specifications	
Operating Temperature	0° to 60°C (32° to 140°F),
Storage Temperature	-20° to 70°C (-4° to 158°F)
Humidity	5 to 95% (non-condensing)
Environmental Air	No corrosive gases permitted
Vibration	IEC60068-2-6 (Test Fc)
Shock	IEC60068-2-27 (Test Ea)
Field to Logic Side Isolation	1800VAC applied for 1s
Insulation Resistance	>10M Ω @ 500VDC
Heat Dissipation	0.36 W
Enclosure Type	Open equipment
Module Keying to Backplane	Electronic
Module Location	Any I/O slot in any local, expansion, or remote base in a Productivity3000® system.
Field Wiring	Removable terminal block (included). The P3-08THM module is not compatible with the ZIP Link wiring system.
Terminal Type	20-position removable terminal block (included)
Weight	150g (5.3 oz)
Agency Approvals	UL508 file E157382, Canada & USA UL1604 file E200031, Canada & USA CE (EN61131-2*) This equipment is suitable for use in Class 1, Division 2, Groups A, B, C and D or non-hazardous locations only.

* Meets EMC and Safety requirements. See the Declaration of Conformity for details.

WARNING: Explosion hazard – Substitution of components may impair suitability for Class I, Division 2.

Removable Terminal Block Specifications	
Number of Positions	20 screw terminals
Wire Range	22–14 AWG (0.324 to 2.08 sq. mm) Solid / stranded conductor 3/64 in. (1.2 mm) insulation maximum USE COPPER CONDUCTORS , 60°C or equivalent.
Screw Driver Width	1/4 inch (6.5 mm) maximum
Screw Size	M3 size
Screw Torque	Field terminals: 7–9 in./lb (0.882–1.02 N·m) Self-jacking screws: 2.7–3.6 in./lb (0.3–0.4 N·m). Do not over-tighten screws when installing terminal block.

* Use shielded, twisted thermocouple wire that matches the thermocouple type.

Configuration/Diagnostics	
Burn-out Detection: High Side/Disable	1-bit per module
°C/°F (T/C only)	1 bit per module
Module Diagnostics Failure	1 bit per module
Burn-out (on if T/C input is open – no connection between TCn+ and TCn-)	1 bit per channel
Channel Under-range (T/C only)	1 bit per channel
Channel Over-range (T/C only)	1 bit per channel

P3-08THM Analog Input (continued)

Wiring Diagrams

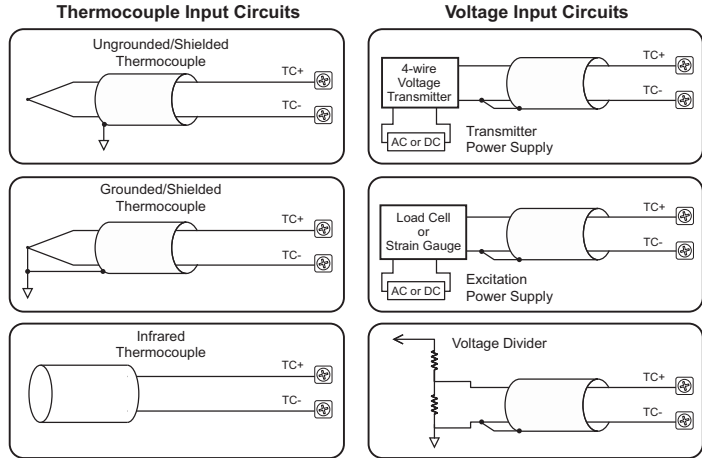

NOTES:

1. Connect shield to thermocouple signal/ground only. Do not connect to both ends.
2. Install jumper wire on each unused input, TC+ to TC-.
3. With grounded thermocouples, take precautions to prevent having a voltage potential between thermocouple tips. A voltage of 1.25V or greater between tips will skew measurements.
4. Use shielded, twisted thermocouple extension wire that matches the thermocouple type. Use thermocouple-compatible junction blocks.

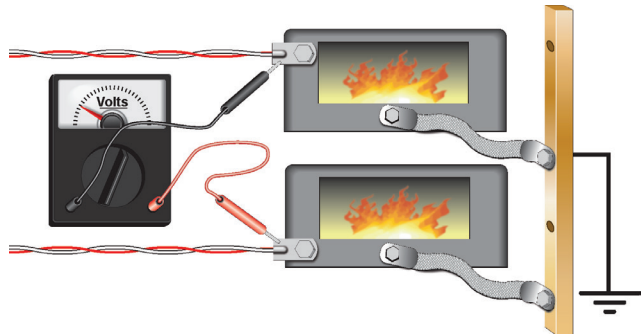
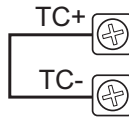
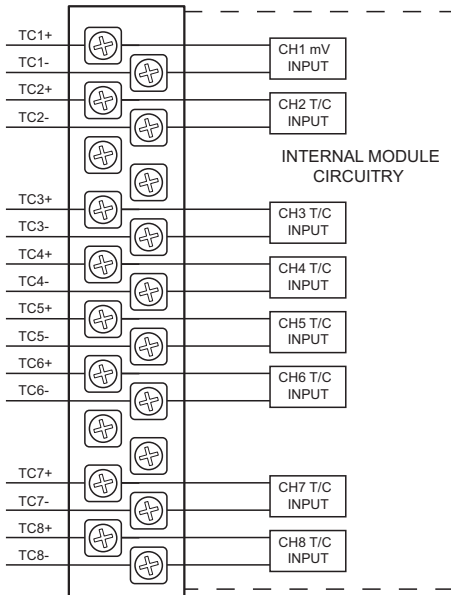

P3-08THM Analog Input (continued)

Module Configuration

Using the Hardware Configuration tool in the Productivity Suite programming software, drag and drop the P3-08THM module into the base configuration.

Select *Automatic Module Verification* or *No Verification and Enable Hot Swap*. Specify *Temperature Scale* and *Burnout Detection*, and use the drop down menu to select module range and resolution, if desired, assign a *User Tagname* to each input point (channel) selected and to each *Status Bit Item*.

8 Channel 16 Bit Thermocouple Input

Automatic Module Verification
 No Verification and Enable Hot Swap

Temperature Scale: Degrees F

Burnout Detection: High Side Burnout Detection

P...	User Tagname	Ch. ...	Range	Burnout Error	Under Range Error	Over Range Error
1	AIF32-0.3.4.1	All <input checked="" type="checkbox"/>	Type J	MST-0.3.4.41	MST-0.3.4.57	MST-0.3.4.89
2	AIF32-0.3.4.2	<input checked="" type="checkbox"/>	Type J	MST-0.3.4.42	MST-0.3.4.58	MST-0.3.4.90
3	AIF32-0.3.4.3	<input checked="" type="checkbox"/>	Type J	MST-0.3.4.43	MST-0.3.4.59	MST-0.3.4.91
4	AIF32-0.3.4.4	<input checked="" type="checkbox"/>	Type J	MST-0.3.4.44	MST-0.3.4.60	MST-0.3.4.92
5	AIF32-0.3.4.5	<input checked="" type="checkbox"/>	Type J	MST-0.3.4.45	MST-0.3.4.61	MST-0.3.4.93
6	AIF32-0.3.4.6	<input checked="" type="checkbox"/>	Type J	MST-0.3.4.46	MST-0.3.4.62	MST-0.3.4.94
7	AIF32-0.3.4.7	<input checked="" type="checkbox"/>	Type J	MST-0.3.4.47	MST-0.3.4.63	MST-0.3.4.95
8	AIF32-0.3.4.8	<input checked="" type="checkbox"/>	Type J	MST-0.3.4.48	MST-0.3.4.64	MST-0.3.4.96

Status Bit Item	User Tagname
Module Failed	MST-0.3.4.25
Module Not Ready	MST-0.3.4.27

P3-08THM Analog Input (continued)

LCD Panel Display

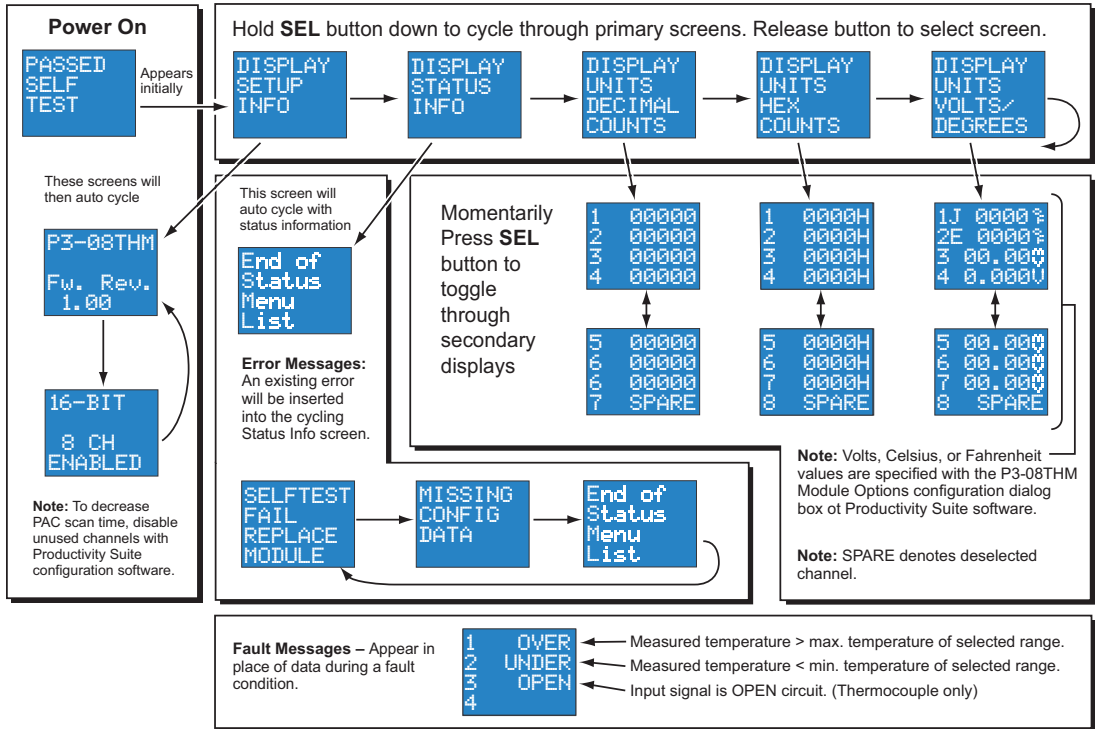

P3-04DA Analog Output

The P3-04DA Voltage/Current Analog Output Module provides four channels of $\pm 10\text{VDC}$ or 4–20 mA sink/source selectable outputs.

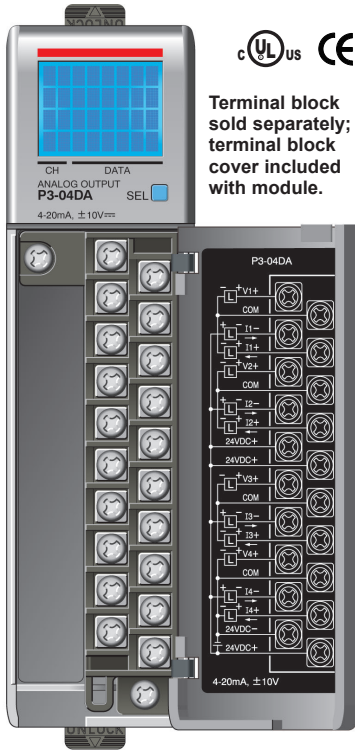

Terminal block sold separately; terminal block cover included with module.

Output Specifications	
Output Channels	4
Module signal output range	$\pm 10\text{V}$ or 4–20 mA sink or source selectable each channel
Signal Resolution	16-bit
Resolution Value of LSB (least significant bit)	$\pm 10\text{V} = 305\mu\text{V}/\text{count}$ 4–20 mA = 0.244 $\mu\text{A}/\text{count}$ 1 LSB = 1 count
Data Range	0–65535 counts unipolar and -32768 to +32767 counts bi-polar
Output Type	Voltage outputs sourcing/sinking at 10mA max, or Current outputs sink or source at 20mA max.
Output Value in Fault Mode	Voltage outputs 0V or 0mA current outputs
Load Impedance (Minimum External Power Supply)	>1000 Ω voltage outputs (19.2–30 VDC) 0–755 Ω Sinking, 0–600 Ω Sourcing (19.2 VDC) 0–875 Ω Sinking, 0–700 Ω Sourcing (21.6 VDC) 0–1000 Ω Sinking, 0–855 Ω Sourcing (24.0 VDC) 0–1110 Ω Sinking, 0–970 Ω Sourcing (26.4 VDC) 0–1350 Ω Sinking, 0–1150 Ω Sourcing (30VDC)
Maximum Capacitive Load	.01 μF maximum voltage outputs
Maximum Inductive Load	1 mH maximum current outputs
Allowed Load Type	Grounded
Maximum Inaccuracy (% of range)	0.1% voltage, 0.1% current (including temperature drift)
Maximum Full Scale Calibration Error (not including offset error)	$\pm 0.025\%$ of range maximum voltage outputs $\pm 0.025\%$ of range maximum current outputs
Accuracy vs. Temperature	± 25 ppm/ $^{\circ}\text{C}$ max f.s. calibration change ($\pm 0.0025\%$ of range / $^{\circ}\text{C}$)
Max Crosstalk	-80dB, 6 LSB
Linearity Error (End to End)	± 16 LSB maximum ($\pm 0.025\%$ of full scale) Monotonic with no missing codes
Output Stability and Repeatability	± 10 LSB after 10 minute warm-up (typical)
Output Ripple	0.05% of Full Scale
Output Settling Time	0.3 ms max, 5 μs min (full scale change)
All Channel Update Rate	0.6ms
Maximum Continuous Overload	Voltage Outputs current limited to 35mA typical. Current Outputs open circuit protected
Type of Output Protection	15VDC Peak Output Voltage Current outputs current limited to $\leq 20\text{mA}$
Output Signal (power-up, -down)	0V voltage outputs, 0mA current outputs
External DC Power Required	94mA voltage operation 4 channels 126mA current operation 4 channels 24VDC -20% / +25%

We recommend using prewired ZIPLink cables and connection modules. See Chapter 5.

Terminal block cover included. If you wish to hand-wire your module, a removable terminal block is sold separately. Order part number P3-RTB.



P3-04DA Analog Output (continued)

General Specifications	
Operating Temperature	0° to 60°C (32° to 140°F),
Storage Temperature	-20° to 70°C (-4° to 158°F)
Humidity	5 to 95% (non-condensing)
Environmental Air	No corrosive gases permitted
Vibration	IEC60068-2-6 (Test Fc)
Shock	IEC60068-2-27 (Test Ea)
Field to Logic Side Isolation	1800VAC applied for 1s
Insulation Resistance	>10MΩ @ 500 VDC
Heat Dissipation	2.6 W voltage outputs 3.4 W current outputs
Enclosure Type	Open equipment
Module Keying to Backplane	Electronic
Module Location	Any I/O slot in any local, expansion, or remote base in a Productivity3000® system.
Field Wiring	Removable terminal block (not included). Use ZIPLink wiring system or optional terminal block. See Chapter 5.
Terminal Type (not included)	20-position removable terminal block
Weight	105g (3.73 oz)
Agency Approvals	UL508 file E157382, Canada & USA UL1604 file E200031, Canada & USA CE (EN61131-2*) This equipment is suitable for use in Class 1, Division 2, Groups A, B, C and D or non-hazardous locations only.

*Meets EMC and Safety requirements. See the Declaration of Conformity for details.

WARNING: Explosion hazard – Substitution of components may impair suitability for Class I, Division 2.

Removable Terminal Block Specifications	
Number of Positions	20 screw terminals
Wire Range	22–14 AWG (0.324 to 2.08 sq. mm) Solid / stranded conductor 3/64 in. (1.2 mm) insulation maximum USE COPPER CONDUCTORS , 60°C or equivalent.
Screw Driver Width	1/4 inch (6.5 mm) maximum
Screw Size	M3 size
Screw Torque	Field terminals: 7–9 in./lb (0.882–1.02 N·m) Self-jacking screws: 2.7–3.6 in./lb (0.3–0.4 N·m). Do not over-tighten screws when installing terminal block.

P3-04DA Analog Output (continued)

Wiring Diagrams

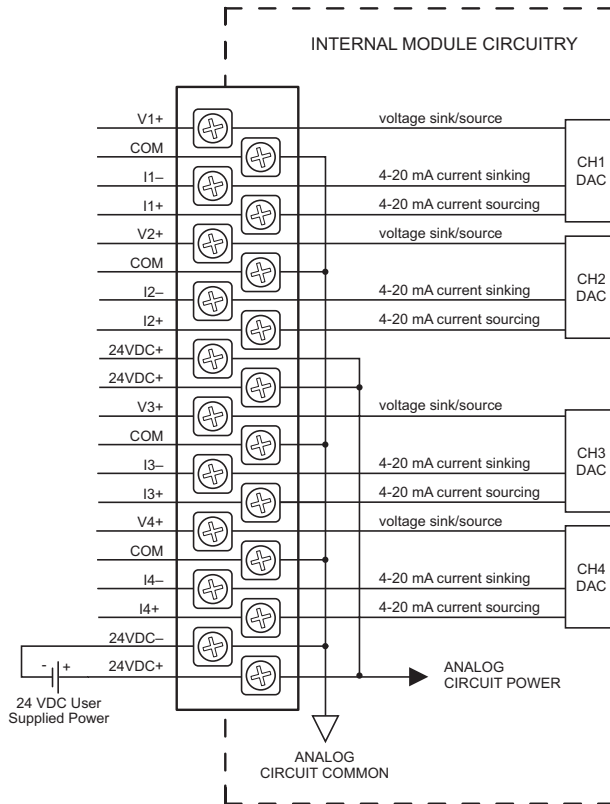

P3-04DA Analog Output (continued)

Wiring Diagrams (continued)

Voltage Output

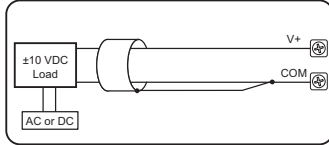
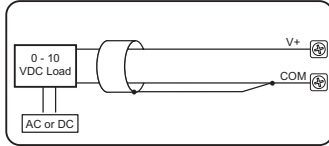

Current Source Output
(Field device is sinking)

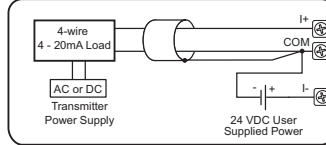
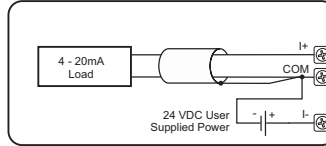

Current Sink Output
(Field device is sourcing)

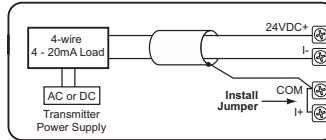
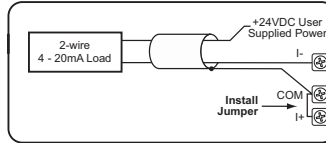

NOTE: Shield is connected to common at the source device.

P3-04DA Analog Output (continued)

Configuration Settings

Using the Hardware Configuration tool in the Productivity Suite programming software, drag and drop the P3-04DA module into the base configuration.

Select *Automatic Module Verification* or *No Verification and Enable Hot Swap*. If desired, assign a *User Tagname* to each output point (channel) selected and to each *Status Bit Item*. *Range* with sink/source option and *Stop Mode Value* may also be assigned.

P3-04DA

4 Channel 16 Bit Bipolar Voltage or Current Sink/Source

Automatic Module Verification
 No Verification and Enable Hot Swap

Point	User Tagname	Select Range	Stop Mode Value
1	AOS32-0.3.5.1	+/-10 V	0
2	AOS32-0.3.5.2	+/-10 V	0
3	AOS32-0.3.5.3	+/-10 V	0
4	AOS32-0.3.5.4	+/-10 V	0

Status Bit Item	User Tagname
Module Failed	MST-0.3.5.25
Missing 24V	MST-0.3.5.26

Monitor Module Info OK Cancel Help

P3-04DA Analog Output (continued)

LCD Panel Display

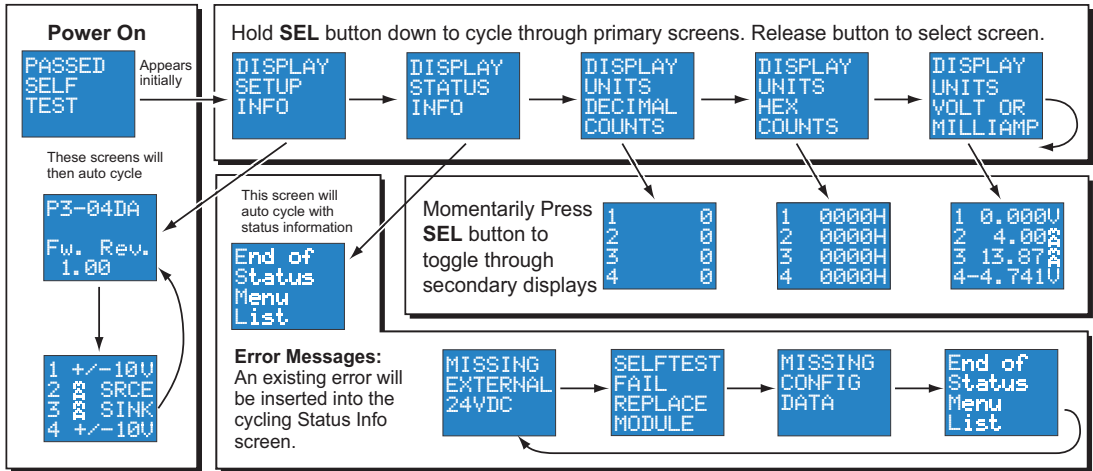

P3-08DA-1 Analog Output

The P3-08DA-1 Current Analog Output Module provides eight channels of 4 to 20mA sourcing outputs.

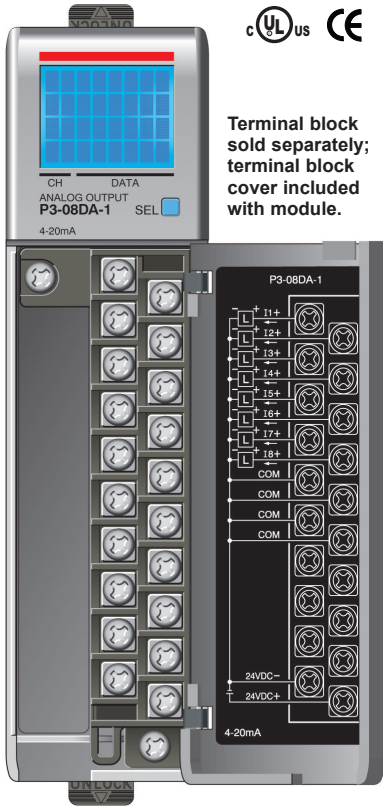

Output Specifications	
Output Channels (commons)	8
Module Signal Output Range	4–20 mA
Output Signal Resolution	16-bit
Resolution Value of LSB (least significant bit)	4–20 mA = 0.244 μ A / count 1 LSB = 1 count
Data Range	0 to 65535 counts
Output Type (sourcing)	Current: 20mA max
Output Value in Fault Mode	Near 0mA
Load Impedance	0–570 Ω (19.2 VDC) 0–690 Ω (21.6 VDC) 0–810 Ω (24.0 VDC) 0–930 Ω (26.4 VDC) 0–1100 Ω (30.0 VDC) Minimum Load 0 Ω @ 0–45°C 125 Ω @ 45–60°C
Maximum Inductive Load	1mH
Allowed Load Type	Grounded
Maximum Inaccuracy	0.1% of range (including temperature drift)
Maximum Full Scale Calibration Error (not including offset error)	\pm 0.025% of range maximum
Maximum Offset Calibration Error	\pm 0.025% of range maximum
Accuracy vs. Temperature	\pm 25ppm/ °C maximum full-scale calibration change (\pm 0.0025% of range / °C)
Max Crosstalk	-96dB, 1 LSB
Linearity Error (end to end)	\pm 16 LSB maximum (\pm 0.025% of full scale) monotonic with no missing codes
Output Stability and Repeatability	\pm 10 count after 10 min. warm-up (typical)
Output Ripple	0.05% of full scale
Output Settling Time	0.3 ms max, 5 μ s min (full scale change)
All channel Update Rate	0.6 ms
Maximum Continuous Overload	Outputs open circuit protected
Type of Output Protection	Electronically current limited to 20mA or less
Output Signal at Power-up and Power-down	4mA
External DC Power Required	24VDC (-20% / + 25%), 180mA

We recommend using prewired ZIPLink cables and connection modules. See Chapter 5.

Terminal block cover included. If you wish to hand-wire your module, a removable terminal block is sold separately. Order part number P3-RTB.



P3-08DA-1 Analog Output (continued)

General Specifications	
Operating Temperature	0° to 60°C (32° to 140°F),
Storage Temperature	-20° to 70°C (-4° to 158°F)
Humidity	5 to 95% (non-condensing)
Environmental Air	No corrosive gases permitted
Vibration	IEC60068-2-6 (Test Fc)
Shock	IEC60068-2-27 (Test Ea)
Field to Logic Side Isolation	1800VAC applied for 1s
Insulation Resistance	>10MΩ @ 500VDC
Heat Dissipation	4.7 W
Enclosure Type	Open equipment
Module Keying to Backplane	Electronic
Module Location	Any I/O slot in any local, expansion, or remote base in a Productivity3000® system.
Field Wiring	Removable terminal block (not included). Use ZIP Link wiring system or optional terminal block. See Chapter 5.
Terminal Type (not included)	20-position removable terminal block
Weight	105g (3.73 oz)
Agency Approvals	UL508 file E157382, Canada & USA UL1604 file E200031, Canada & USA CE (EN61131-2*) This equipment is suitable for use in Class 1, Division 2, Groups A, B, C and D or non-hazardous locations only.

*Meets EMC and Safety requirements. See the Declaration of Conformity for details.

WARNING: Explosion hazard – Substitution of components may impair suitability for Class I, Division 2.

Removable Terminal Block Specifications	
Number of Positions	20 screw terminals
Wire Range	22–14 AWG (0.324 to 2.08 sq. mm) Solid / stranded conductor 3/64 in. (1.2 mm) insulation maximum USE COPPER CONDUCTORS , 60°C or equivalent.
Screw Driver Width	1/4 inch (6.5 mm) maximum
Screw Size	M3 size
Screw Torque	Field terminals: 7–9 in./lb (0.882–1.02 N·m) Self-jacking screws: 2.7–3.6 in./lb (0.3–0.4 N·m). Do not over-tighten screws when installing terminal block.

P3-08DA-1 Analog Output (continued)

Wiring Diagrams

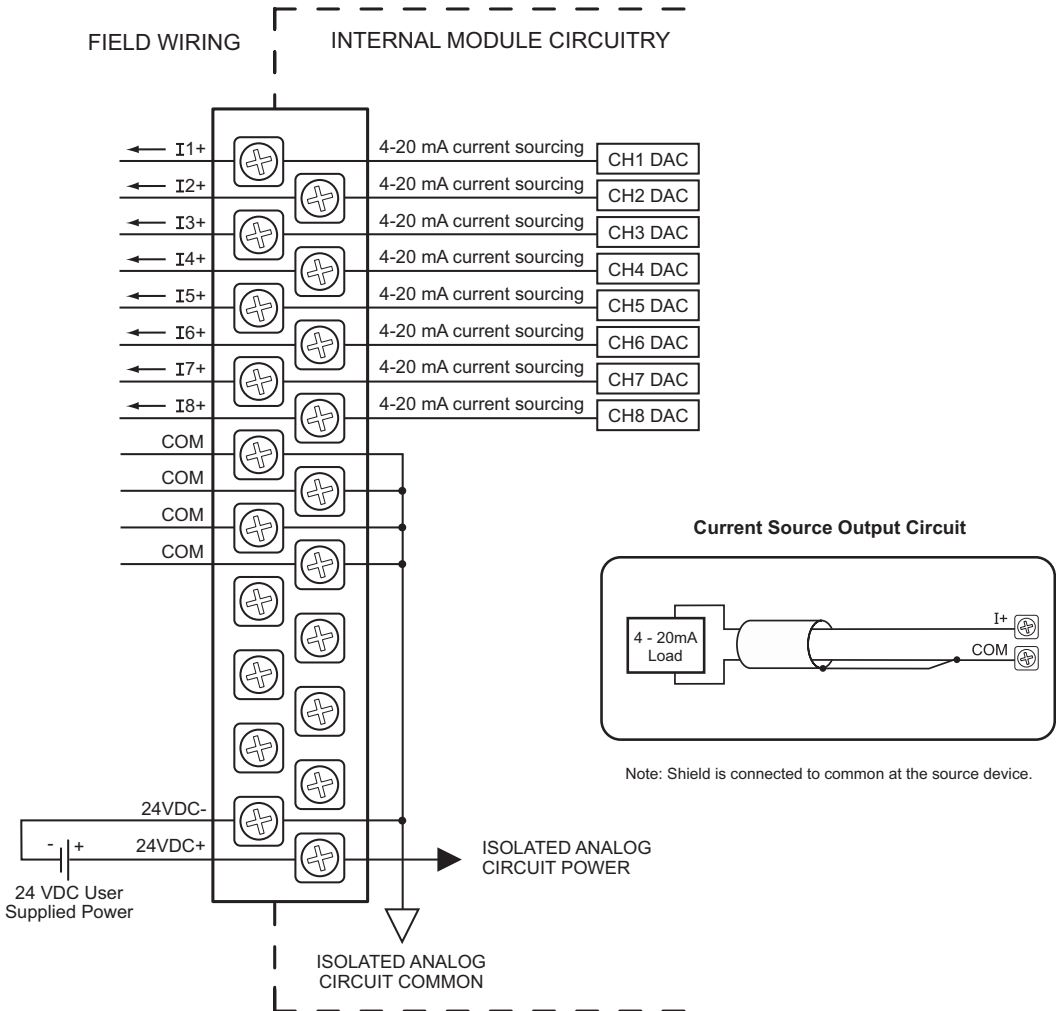

P3-08DA-1 Analog Output (continued)

Module Configuration

Using the Hardware Configuration tool in the Productivity Suite programming software, drag and drop the P3-08DA-1 module into the base configuration.

Select *Automatic Module Verification* or *No Verification and Enable Hot Swap*. If desired, assign a *User Tagname* to each output point (channel) selected and to each *Status Bit Item*. A *Stop Mode Value* may also be assigned.

8 Channel 16 Bit Current Sourcing Analog Out

Automatic Module Verification

No Verification and Enable Hot Swap

Point	User Tagname	Stop Mode Value
1	AOS32-0.3.6.1	0
2	AOS32-0.3.6.2	0
3	AOS32-0.3.6.3	0
4	AOS32-0.3.6.4	0
5	AOS32-0.3.6.5	0
6	AOS32-0.3.6.6	0
7	AOS32-0.3.6.7	0
8	AOS32-0.3.6.8	0

Status Bit Item	User Tagname
Module Failed	MST-0.3.6.25
Missing 24V	MST-0.3.6.26

Monitor Module Info OK Cancel Help

P3-08DA-1 Analog Output (continued)

LCD Panel Display

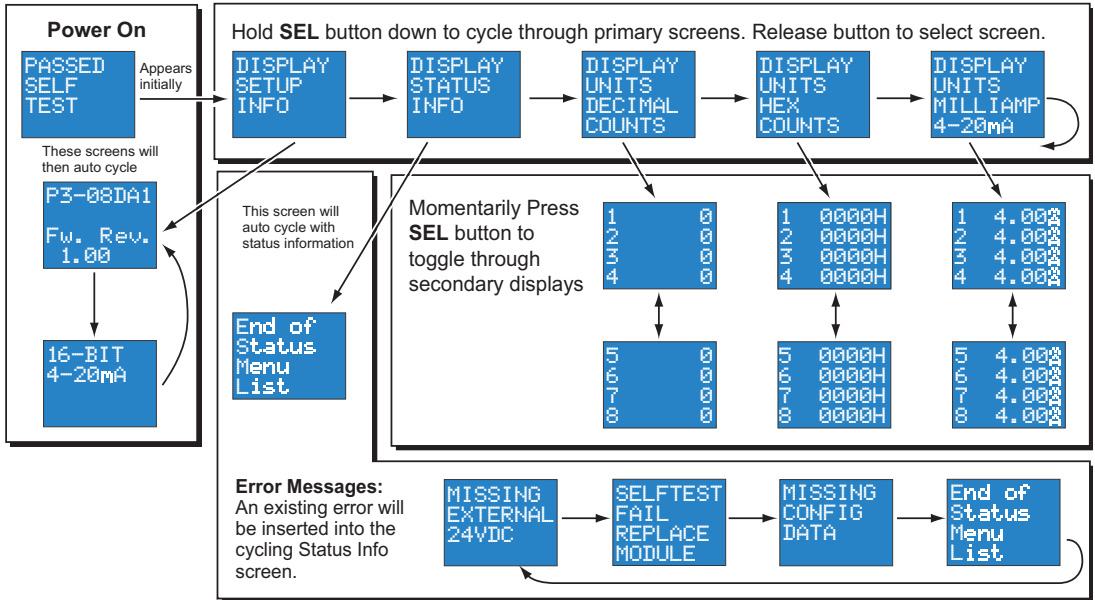

P3-08DA-2 Analog Output

The P3-08DA-2 Voltage Analog Output Module provides eight channels of ± 10 VDC outputs.

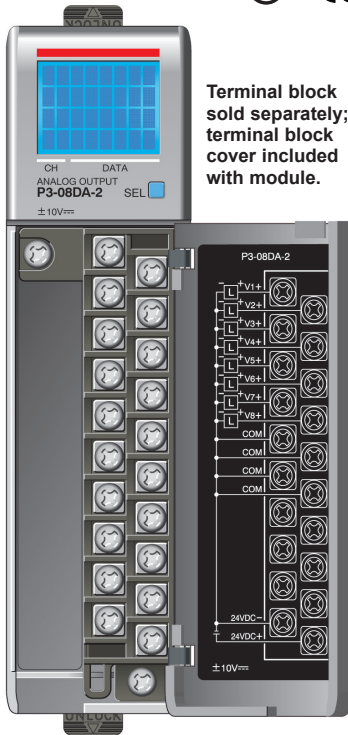

Terminal block sold separately; terminal block cover included with module.

Output Specifications	
Output Channels	8
Module Signal Output Range	± 10 VDC
Output Signal Resolution	16-bit
Resolution Value of LSB (least significant bit)	± 10 V = $305 \mu\text{V}/\text{count}$ 1 LSB = 1 count
Data range	-32768 to +32767
Output Type (sourcing/sinking)	Voltage (10mA max current)
Output Value in Fault Mode	0V
Load Impedance	$\leq 1000 \Omega$
Maximum Capacitive Load	0.01 μF maximum
Allowed Load Type	Grounded
Maximum Inaccuracy	0.1% of range (including temperature drift)
Maximum Full Scale Calibration Error (not including offset error)	$\pm 0.025\%$ of range maximum
Maximum Offset Calibration Error	$\pm 0.025\%$ of range maximum
Accuracy vs. Temperature	$\pm 25 \text{ppm}/^\circ\text{C}$ maximum full scale calibration change ($\pm .0025\%$ of range / $^\circ\text{C}$)
Max Crosstalk	-96 dB, 1 LSB
Linearity Error (End to End)	± 16 LSB maximum ($\pm 0.025\%$ of full scale) Monotonic with no missing codes
Output Stability and Repeatability	± 10 LSB after 10 min. warm-up (typical)
Output Ripple	0.05% of full-scale
Output Settling Time	0.3 ms max, 5 μs min (full scale change)
All Channel Update Rate (typical)	0.6ms
Maximum Continuous Overload	Outputs current limited to 40mA typical Continuous overloads on multiple outputs can damage the module.
Type of Output Protection	0.1 μF Transient Suppressor
Output Signal (power-up, -down)	0V
External DC Power Required	24VDC (-20% / + 25%), 120mA

We recommend using prewired ZIPLink cables and connection modules. See Chapter 5.

Terminal block cover included. If you wish to hand-wire your module, a removable terminal block is sold separately. Order part number P3-RTB.



P3-08DA-2 Analog Output (continued)

General Specifications	
Operating Temperature	0° to 60°C (32° to 140°F),
Storage Temperature	-20° to 70°C (-4° to 158°F)
Humidity	5 to 95% (non-condensing)
Environmental Air	No corrosive gases permitted
Vibration	IEC60068-2-6 (Test Fc)
Shock	IEC60068-2-27 (Test Ea)
Field to Logic Side Isolation	1800 VAC applied for 1s
Insulation Resistance	>10MΩ @ 500VDC
Heat Dissipation	3.3 W
Enclosure Type	Open equipment
Module Keying to Backplane	Electronic
Module Location	Any I/O slot in any local, expansion, or remote base in a Productivity3000® system.
Field Wiring	Removable terminal block (not included). Use ZIP Link wiring system or optional terminal block. See Chapter 5.
Terminal Type (not included)	20-position removable terminal block
Weight	105g (3.73 oz)
Agency Approvals	UL508 file E157382, Canada & USA UL1604 file E200031, Canada & USA CE (EN61131-2*) This equipment is suitable for use in Class 1, Division 2, Groups A, B, C and D or non-hazardous locations only.

*Meets EMC and Safety requirements. See the Declaration of Conformity for details.

WARNING: Explosion hazard – Substitution of components may impair suitability for Class I, Division 2.

Removable Terminal Block Specifications	
Number of Positions	20 screw terminals
Wire Range	22–14 AWG (0.324 to 2.08 sq. mm) Solid / stranded conductor 3/64 in. (1.2 mm) insulation maximum USE COPPER CONDUCTORS , 60°C or equivalent.
Screw Driver Width	1/4 inch (6.5 mm) maximum
Screw Size	M3 size
Screw Torque	Field terminals: 7–9 in./lb (0.882–1.02 N·m) Self-jacking screws: 2.7–3.6 in./lb (0.3–0.4 N·m). Do not over-tighten screws when installing terminal block.

P3-08DA-2 Analog Output (continued)

Wiring Diagrams

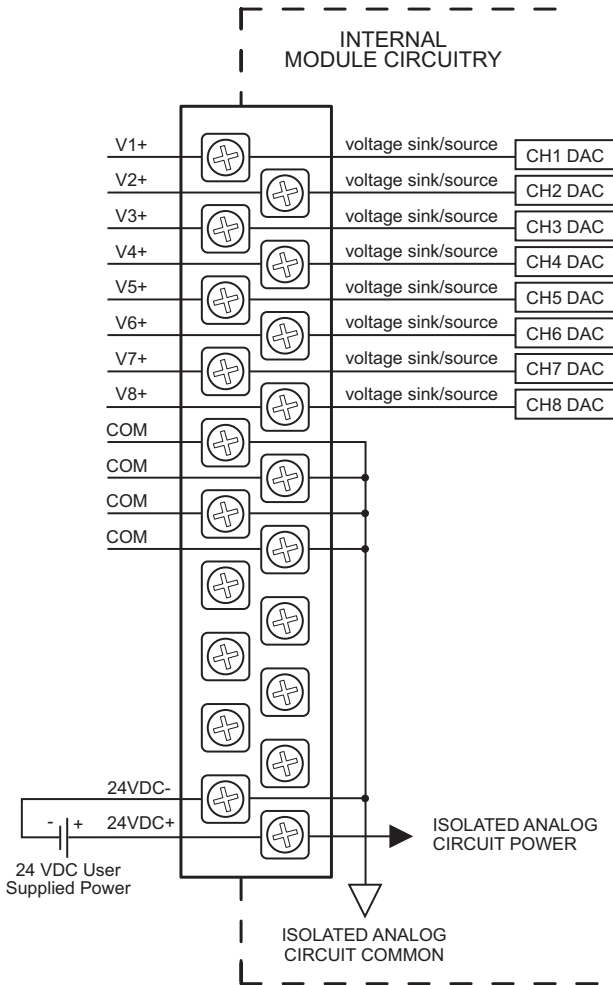

Voltage Output Circuits

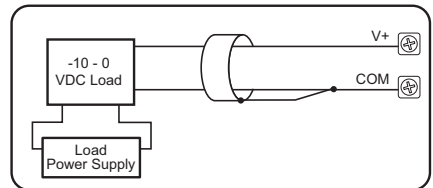
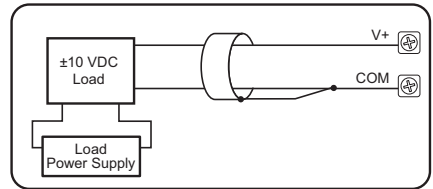
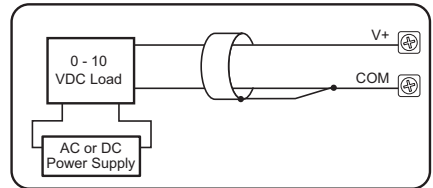

P3-08DA-2 Analog Output (continued)

Module Configuration

Using the Hardware Configuration tool in the Productivity Suite programming software, drag and drop the P3-08DA-2 module into the base configuration.

Select *Automatic Module Verification* or *No Verification and Enable Hot Swap* and *Stop Mode Values*. If desired, assign a *User Tagname* to each output point (channel) selected and to each *Status Bit Item*.

P3-08DA-2

8 Channel 16 Bit Voltage Analog Out

Automatic Module Verification
 No Verification and Enable Hot Swap

Point	User Tagname	Stop Mode Value
1	AOS32-0.3.7.1	0
2	AOS32-0.3.7.2	0
3	AOS32-0.3.7.3	0
4	AOS32-0.3.7.4	0
5	AOS32-0.3.7.5	0
6	AOS32-0.3.7.6	0
7	AOS32-0.3.7.7	0
8	AOS32-0.3.7.8	0

Status Bit Item	User Tagname
Module Failed	MST-0.3.7.25
Missing 24V	MST-0.3.7.26

P3-08DA-2 Analog Output (continued)

LCD Panel Display

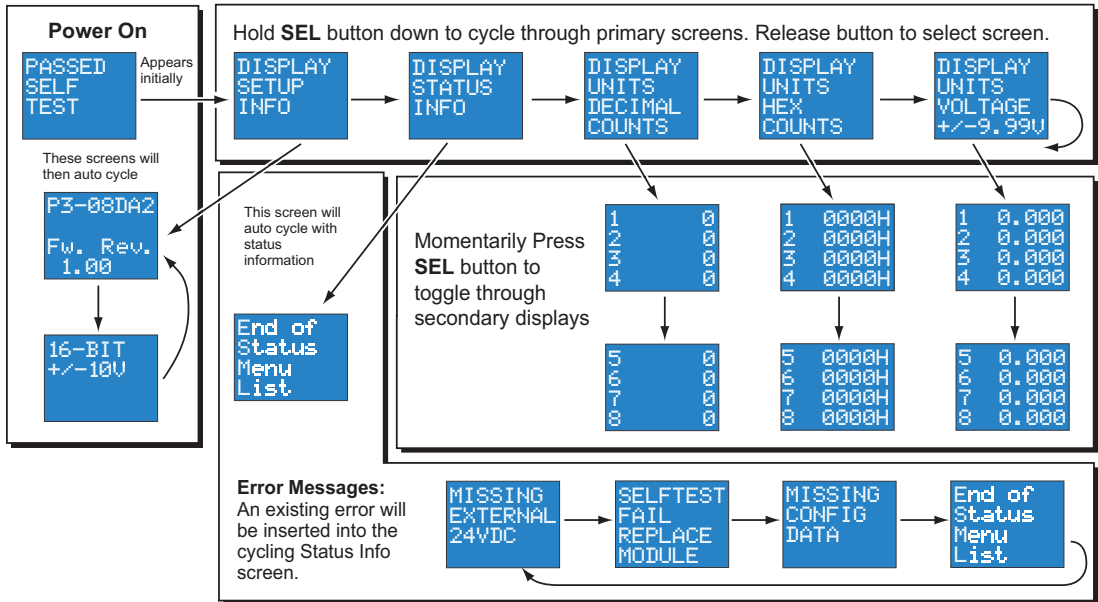

P3-06DAS-1 Isolated Analog Output (Retired)

The P3-06DAS-1 Current Analog Output Module provides six channel-to-channel isolated 4–20 mA outputs.

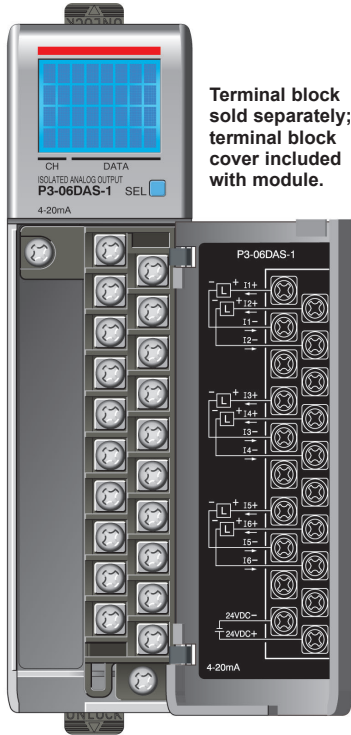

Terminal block sold separately; terminal block cover included with module.

Output Specifications	
Output channels (commons)	6 (6 isolated)
Module Signal Output Range	4–20 mA
Signal Resolution	16-bit
Resolution Value of LSB (least significant bit)	4–20mA = 0.244 μ A/count 1 LSB = 1 count
Data Range	0 to 65535 counts
Output Type (sourcing)	Current: 20mA max (isolated)*
Channel to AUX Power Isolation	1800VDC applied for 1.8 second (100% tested)
Channel to Channel Isolation	900VDC applied for 1.8 second (100% tested)
Output Value in Fault Mode	Less than 4mA
Load Impedance	0–750 Ω
Maximum Inductive Load	1mH
Allowed Load Type	Floating or Grounded
Maximum Inaccuracy	0.1% of range
Maximum Full Scale Calibration Error (not including offset error)	\pm 0.065% of range maximum
Maximum Offset Calibration Error	\pm 0.065% of range maximum
Accuracy vs. Temperature	\pm 25 ppm/ $^{\circ}$ C maximum full scale calibration change (\pm 0.0025% of range / $^{\circ}$ C)
Max Crosstalk (DC, 50 Hz, 60 Hz)	-96dB, 1 LSB**
Linearity Error (end to end)	\pm 16 LSB maximum (\pm 0.025% of full scale) monotonic with no missing codes
Output Stability and Repeatability	\pm 16 LSB after 10 min. warm-up (typical)
Output Settling Time	0.3 ms maximum, 5 μ s minimum (full scale change)
All Channel Update Rate	0.6 ms
Type of Output Protection	Electronically current limited to 20mA or less
Output Signal (power-up, -down)	Less than or equal to 4mA***
External DC Power Required	24VDC (-20% / + 25%), 250mA

*Module generates isolated loop power for each channel
 **To achieve maximum crosstalk per spec, isolation must be maintained, all commons have to be separated
 ***Less than 4mA, if the module is not configured or in the RESET stage

We recommend using prewired ZIPLink cables and connection modules. See Chapter 5.

Terminal block cover included. If you wish to hand-wire your module, a removable terminal block is sold separately. Order part number P3-RTB.



P3-06DAS-1 was retired 09/2023

P3-06DAS-1 Isolated Analog Output (continued)

General Specifications	
Operating Temperature	0° to 60°C (32° to 140°F)
Storage Temperature	-20° to 70°C (-4° to 158°F)
Humidity	5 to 95% (non-condensing)
Environmental Air	No corrosive gases permitted
Vibration	IEC60068-2-6 (Test Fc)
Shock	IEC60068-2-27 (Test Ea)
Field to Logic Side Isolation	1800 VDC applied for 1.8 seconds (100% tested)
Insulation Resistance	>10MΩ @ 500VDC
Heat Dissipation	3.38 W
Enclosure Type	Open equipment
Module Keying to Backplane	Electronic
Module Location	Any I/O slot in any local, expansion, or remote base in a Productivity3000® system.
Field Wiring	Removable terminal block (not included). Use ZIP Link wiring system or optional terminal block. See Chapter 5.
Terminal Type (not included)	20-position removable terminal block
Weight	108.8 g (3.82 oz)
Agency Approvals	UL508 file E157382, Canada & USA UL1604 file E200031, Canada & USA CE (EN61131-2*) This equipment is suitable for use in Class 1, Division 2, Groups A, B, C and D or non-hazardous locations only.

*Meets EMC and Safety requirements. See the Declaration of Conformity for details.

Removable Terminal Block Specifications	
Number of Positions	20 screw terminals
Wire Range	22–14 AWG (0.324 to 2.08 sq. mm) Solid / stranded conductor 3/64 in. (1.2 mm) insulation maximum USE COPPER CONDUCTORS , 60°C or equivalent.
Screw Driver Width	1/4 inch (6.5 mm) maximum
Screw Size	M3 size
Screw Torque	Field terminals: 7–9 in./lb (0.882–1.02 N·m) Self-jacking screws: 2.7–3.6 in./lb (0.3–0.4 N·m). Do not over-tighten screws when installing terminal block.

P3-06DAS-1 Isolated Analog Output (continued)

Wiring Diagrams

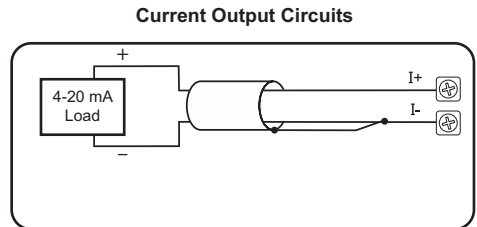
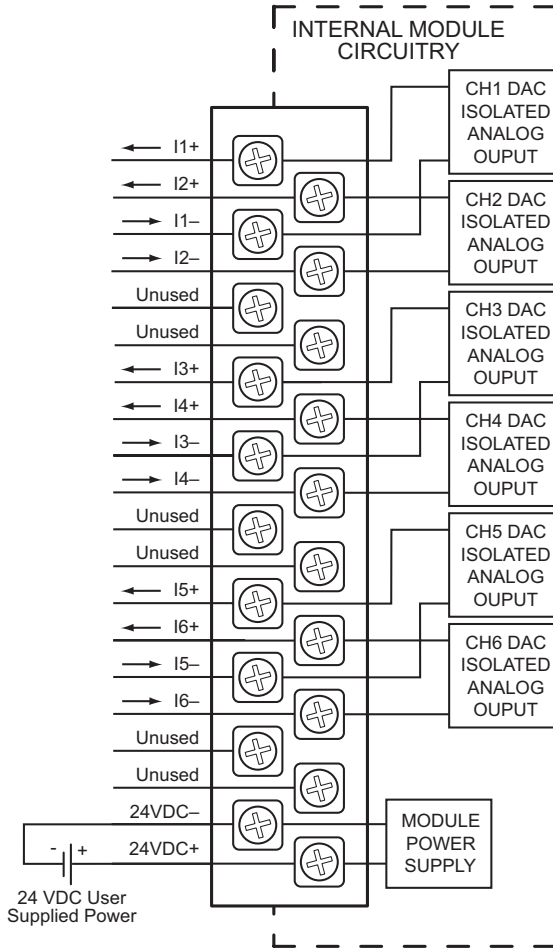

- NOTES:
1. Shield connected to signal source common.
 2. Isolated analog outputs can work with sinking and sourcing field devices.

P3-06DAS-1 Isolated Analog Output (continued)

Module Configuration

Using the Hardware Configuration tool in the Productivity Suite programming software, drag and drop the P3-06DAS-1 module into the base configuration.

Select *Automatic Module Verification* or *No Verification and Enable Hot Swap* and *Enable Hot Swap* and *Stop Mode Values*. If desired, assign a *User Tagname* to each output point (channel) selected and to each *Status Bit Item*.

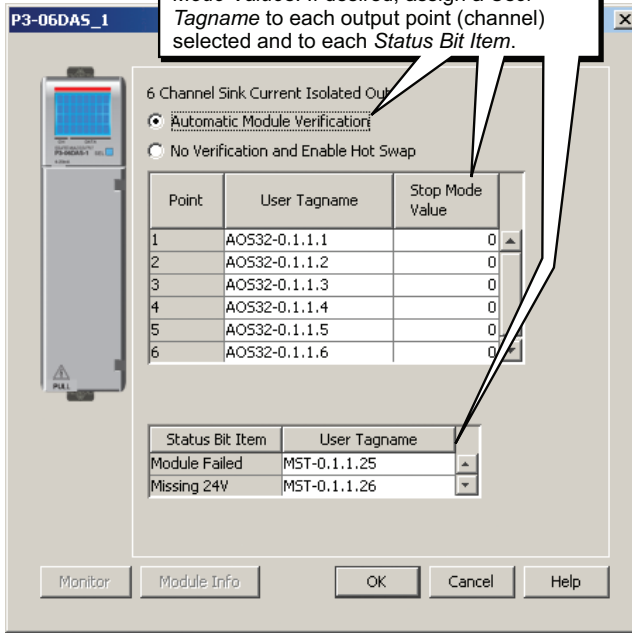

P3-06DAS-1 Isolated Analog Output (continued)

LCD Panel Display

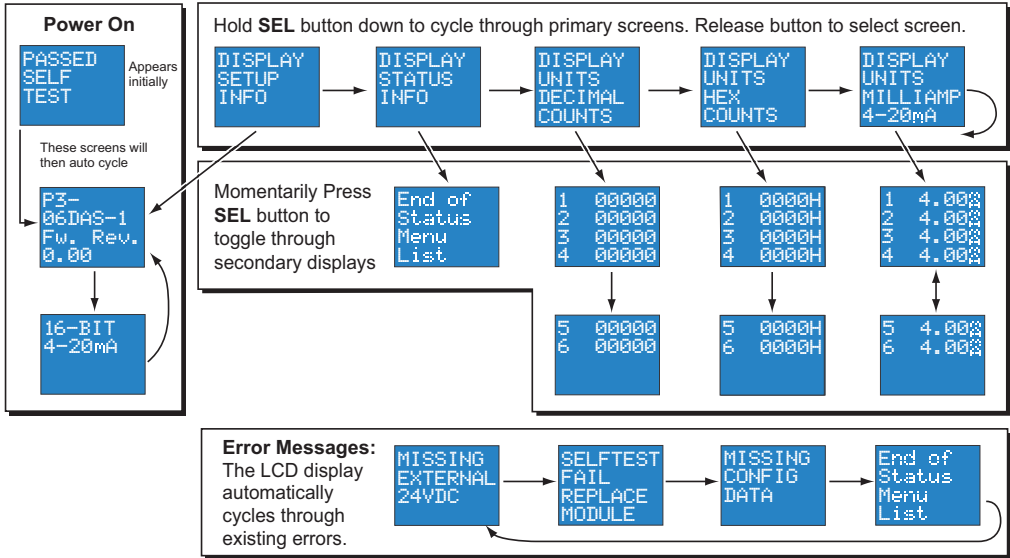

P3-06DAS-2 Isolated Analog Output (Retired)

The P3-06DAS-2 Voltage Analog Output Module provides six channel-to-channel isolated $\pm 10\text{VDC}$ outputs.

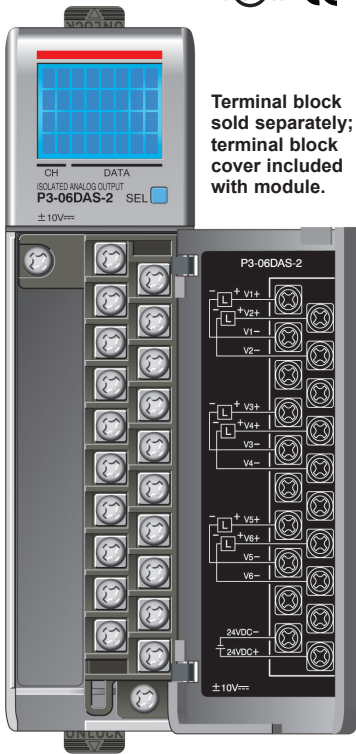

Terminal block sold separately; terminal block cover included with module.

Output Specifications	
Output channels	6 (6 isolated)
Module Signal Output Range	$\pm 10\text{V}$
Signal Resolution	16 bit
Resolution Value of LSB (least significant bit)	16 Bit Resolution $\pm 10\text{V} = 305\mu\text{V}$
Data Range	-32768 to +32767 counts
Output Type (sourcing/sinking)	Voltage (10mA max current)
Channel to AUX Power Isolation	1800VDC applied for 1.8 second (100% tested)
Channel to Channel Isolation	900VDC applied for 1.8 second (100% tested)
Output Value in Fault Mode	0V
Load Impedance	$\leq 1000\Omega$
Maximum Capacitive Load	0.01 μF maximum
Allowed Load Type	Floating or grounded
Maximum Inaccuracy	$\pm 0.1\%$ of range
Maximum Full Scale Calibration Error (not including offset error)	$\pm 0.065\%$ of range maximum voltage
Maximum Offset Calibration Error	$\pm 0.065\%$ of range maximum
Accuracy vs. Temperature	± 25 ppm/ $^{\circ}\text{C}$ maximum f.s. calibration change ($\pm 0.0025\%$ of range / $^{\circ}\text{C}$)
Maximum Crosstalk	-96dB, 1 LSB
Linearity Error (End to End)	± 16 LSB maximum ($\pm 0.025\%$ of full scale) Monotonic with no missing codes
Output Stability and Repeatability	± 10 LSB after 10 min. warm-up (typical)
Output Ripple	0.01% of full scale
Output Settling Time	0.100 μs max, 40 μs min (full scale change)
All Channel Update Rate	1.05 ms
Maximum Continuous Overload	Outputs current limited to 15mA typical
Type of Output Protection	15VDC Peak Output Voltage
Output Signal (power-up, -down)	0V
External DC Power Required	24VDC (-20% / + 25%), 287mA

P3-06DAS-2 was retired 03/2024

We recommend using prewired ZIPLink cables and connection modules. See Chapter 5.

Terminal block cover included. If you wish to hand-wire your module, a removable terminal block is sold separately. Order part number P3-RTB.



P3-06DAS-2 Isolated Analog Output (continued)

General Specifications	
Operating Temperature	0° to 60°C (32° to 140°F),
Storage Temperature	-20° to 70°C (-4° to 158°F)
Humidity	5 to 95% (non-condensing)
Environmental Air	No corrosive gases permitted
Vibration	IEC60068-2-6 (Test Fc)
Shock	IEC60068-2-27 (Test Ea)
Field to Logic Side Isolation	1800 VDC applied for 1.8 seconds (100% tested)
Insulation Resistance	>10MΩ @ 500VDC
Heat Dissipation	5.8 W
Enclosure Type	Open equipment
Module Keying to Backplane	Electronic
Module Location	Any I/O slot in any local, expansion, or remote base in a Productivity3000® system.
Field Wiring	Removable terminal block (not included). Use ZIPL ink wiring system or optional terminal block. See Chapter 5.
Terminal Type (not included)	20-position removable terminal block
Weight	108.8g (3.82 oz)
Agency Approvals	UL508 file E157382, Canada & USA UL1604 file E200031, Canada & USA CE (EN61131-2*) This equipment is suitable for use in Class 1, Division 2, Groups A, B, C and D or non-hazardous locations only.

*Meets EMC and Safety requirements. See the Declaration of Conformity for details.

WARNING: Explosion hazard – Substitution of components may impair suitability for Class I, Division 2.

Removable Terminal Block Specifications	
Number of Positions	20 screw terminals
Wire Range	22–14 AWG (0.324 to 2.08 sq. mm) Solid / stranded conductor 3/64 in. (1.2 mm) insulation maximum USE COPPER CONDUCTORS , 60°C or equivalent.
Screw Driver Width	1/4 inch (6.5 mm) maximum
Screw Size	M3 size
Screw Torque	Field terminals: 7–9 in./lb (0.882–1.02 N·m) Self-jacking screws: 2.7–3.6 in./lb (0.3–0.4 N·m). Do not over-tighten screws when installing terminal block.

P3-06DAS-2 Isolated Analog Output (continued)

Wiring Diagrams

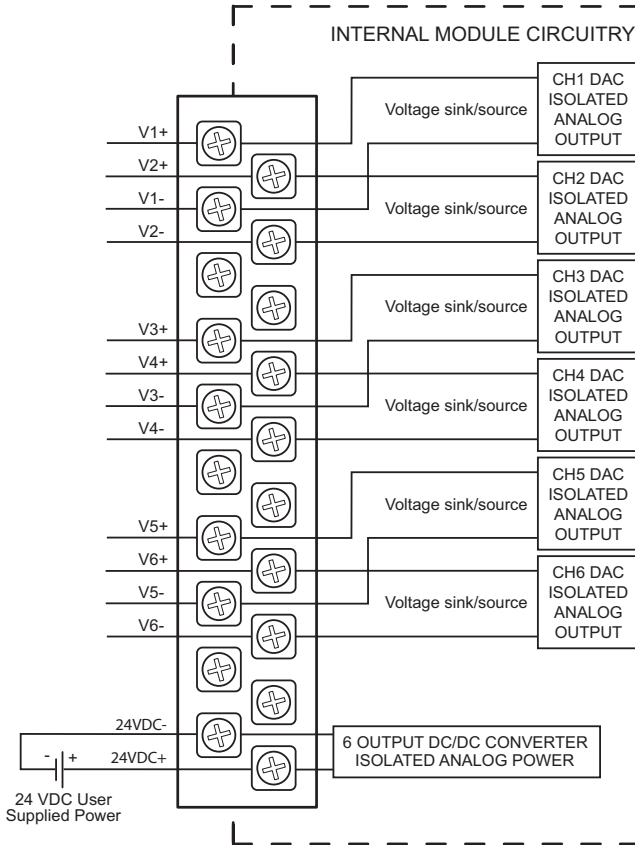

Voltage Output Circuits

V- can be either isolated or grounded.

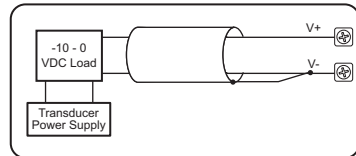
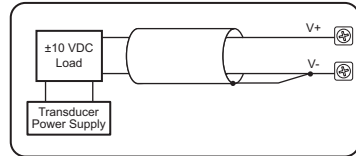
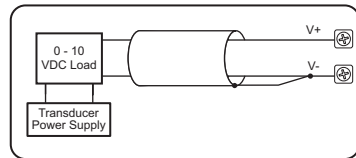

NOTES: Shield connected to signal source common.

P3-06DAS-2 Isolated Analog Output (continued)

Module Configuration

Using the Hardware Configuration tool in the Productivity Suite programming software, drag and drop the P3-06DAS-2 module into the base configuration.

Select *Automatic Module Verification* or *No Verification and Enable Hot Swap* and *Stop Mode Values*. If desired, assign a *User Tagname* to each output point (channel) selected and to each *Status Bit Item*.

6 Channel 16 Bit Isolated Voltage Out

Automatic Module Verification
 No Verification and Enable Hot Swap

Point	User Tagname	Stop Mode Value
1	AOS32-0.3.9.1	0
2	AOS32-0.3.9.2	0
3	AOS32-0.3.9.3	0
4	AOS32-0.3.9.4	0
5	AOS32-0.3.9.5	0
6	AOS32-0.3.9.6	0

Status Bit Item	User Tagname
Module Failed	MST-0.3.9.25
Missing 24V	MST-0.3.9.26

P3-06DAS-2 Isolated Analog Output (continued)

LCD Panel Display

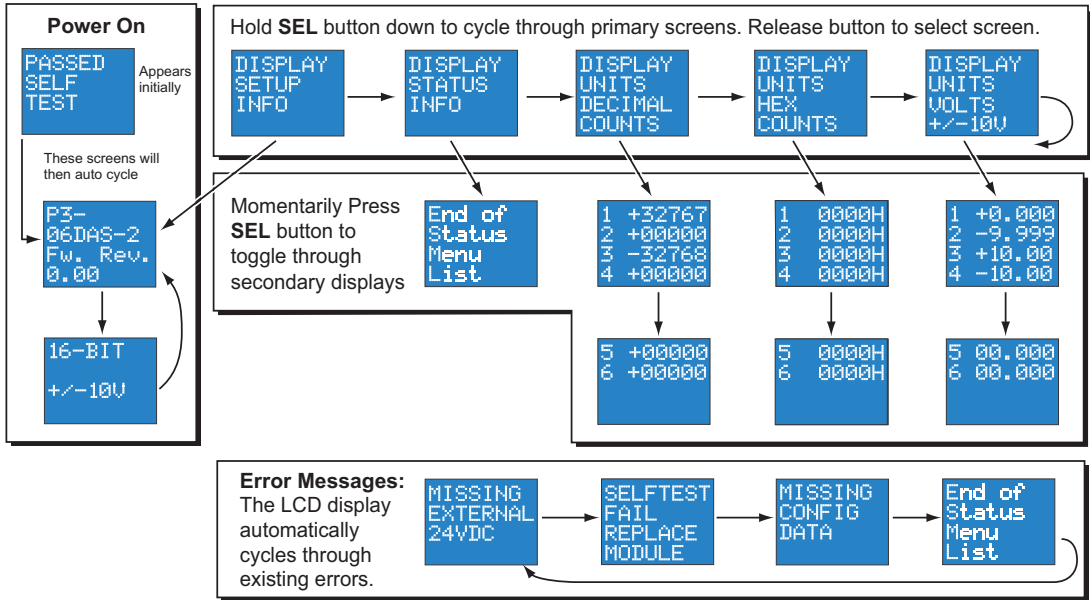

P3-16DA-1 Analog Output

The P3-16DA-1 Current Analog Output Module provides sixteen channels of 4–20 mA sourcing outputs.

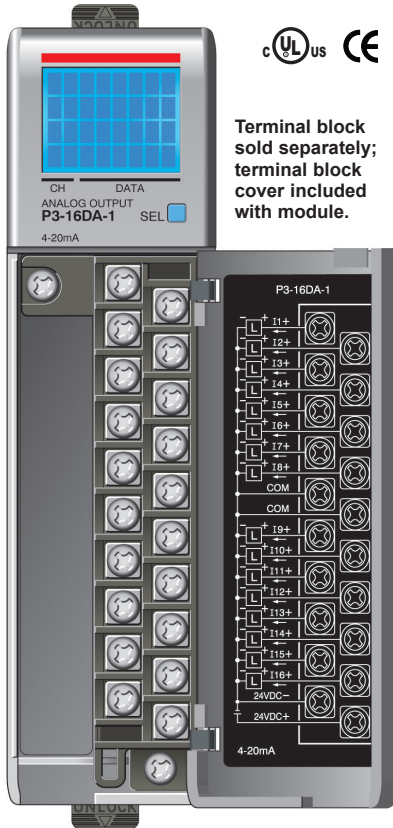

Terminal block sold separately; terminal block cover included with module.

Output Specifications

Output Channels	16 (non-isolated)
Module Signal Output Range	4–20 mA
Output Signal Resolution	16-bit
Resolution Value of LSB (least significant bit)	4–20 mA = 0.244 μ A/count 1 LSB = 1 count
Data Range	0 to 65535 counts
Output Value in Fault Mode	Less than 4mA
Load Impedance (Minimum External Power Supply)	0–570 Ω (19.2 VDC) 0–690 Ω (21.6 VDC) 0–810 Ω (24.0 VDC) 0–930 Ω (26.4 VDC) 0–1100 Ω (30.0 VDC) Minimum Load 0 Ω @ 0–45°C, 125 Ω @45–60°C, ambient
Maximum Inductive Load	1mH
Allowed Load Type	Grounded
Maximum Inaccuracy	0.1% of range (including temperature drift)
Maximum Full Scale Calibration Error (not including offset error)	\pm 0.025% of range maximum
Maximum Offset Calibration Error	\pm 0.025% of range maximum
Accuracy vs. Temperature	\pm 25ppm/°C maximum full scale calibration change (\pm .0025% of range / °C)
Max Crosstalk	-96dB, 1 LSB
Linearity Error (end to end)	\pm 16 LSB maximum (\pm 0.025% of full scale) monotonic with no missing codes
Output Stability and Repeatability	\pm 10 LSB after 10 min. warm-up (typical)
Output Ripple	0.05% of full scale
Output Settling Time	0.3 ms max, 5 μ s min (full scale change)
All Channel Update Rate	0.6 ms
Maximum Continuous Overload	Outputs open circuit protected
Type of Output Protection	Electronically current limited to 20mA or less
Output Signal at Power-up and Power-down	4mA
External DC Power Required	24VDC (-20% / + 25%), 356mA

We recommend using prewired ZIPLink cables and connection modules. See Chapter 5.

Terminal block cover included. If you wish to hand-wire your module, a removable terminal block is sold separately. Order part number P3-RTB.



P3-16DA-1 Analog Output (continued)

General Specifications	
Operating Temperature	0° to 60°C (32° to 140°F),
Storage Temperature	-20° to 70°C (-4° to 158°F)
Humidity	5 to 95% (non-condensing)
Environmental Air	No corrosive gases permitted
Vibration	IEC60068-2-6 (Test Fc)
Shock	IEC60068-2-27 (Test Ea)
Field to Logic Side Isolation	1800VAC applied for 1s
Insulation Resistance	>10MΩ @ 500VDC
Heat Dissipation	9.0 W
Enclosure Type	Open equipment
Module Keying to Backplane	Electronic
Module Location	Any I/O slot in any local, expansion, or remote base in a Productivity3000® system.
Field Wiring	Removable terminal block (not included). Use ZIPL ink wiring system or optional terminal block. See Chapter 5.
Terminal Type (not included)	20-position removable terminal block
Weight	105g (3.73 oz)
Agency Approvals	UL508 and UL1604 (Certified for Canada and USA) CE (EN61131-2:2003) This equipment is suitable for use in Class I, Division 2/Zone 2, Groups A, B, C, and D or non-hazardous locations only.

**Meets EMC and Safety requirements. See the Declaration of Conformity for details.*

WARNING: Explosion hazard – Substitution of components may impair suitability for Class I, Division 2.

Removable Terminal Block Specifications	
Number of Positions	20 screw terminals
Wire Range	22–14 AWG (0.324 to 2.08 sq. mm) Solid / stranded conductor 3/64 in. (1.2 mm) insulation maximum USE COPPER CONDUCTORS , 60°C or equivalent.
Screw Driver Width	1/4 inch (6.5 mm) maximum
Screw Size	M3 size
Screw Torque	Field terminals: 7–9 in./lb (0.882–1.02 N·m) Self-jacking screws: 2.7–3.6 in./lb (0.3–0.4 N·m). Do not over-tighten screws when installing terminal block.

P3-16DA-1 Analog Output (continued)

Wiring Diagrams

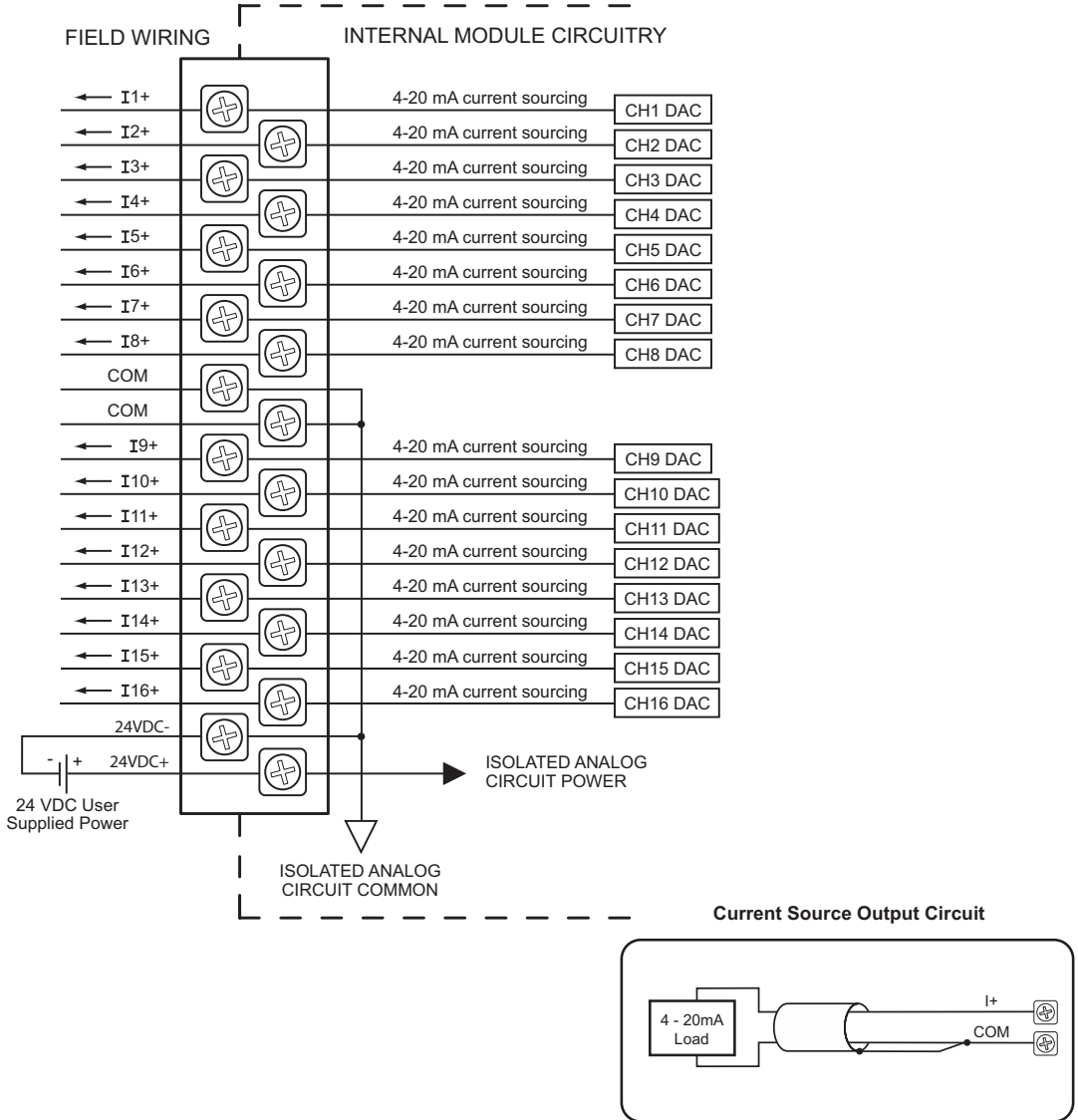

NOTE: Shield is connected to common at the source device.

P3-16DA-1 Analog Output (continued)

Module Configuration

Using the Hardware Configuration tool in the Productivity Suite programming software, drag and drop the P3-16DA-1 module into the base configuration.

Select *Automatic Module Verification* or *No Verification and Enable Hot Swap* and *Stop Mode Values*. If desired, assign a *User Tagname* to each output point (channel) selected and to each *Status Bit Item*.

Point	User Tagname	Stop Mode Value
1	AOS32-0.3.10.1	0
2	AOS32-0.3.10.2	0
3	AOS32-0.3.10.3	0
4	AOS32-0.3.10.4	0
5	AOS32-0.3.10.5	0
6	AOS32-0.3.10.6	0
7	AOS32-0.3.10.7	0
8	AOS32-0.3.10.8	0

Status Bit Item	User Tagname
Module Failed	MST-0.3.10.25
Missing 24V	MST-0.3.10.26

P3-16DA-1 Analog Output (continued)

LCD Panel Display

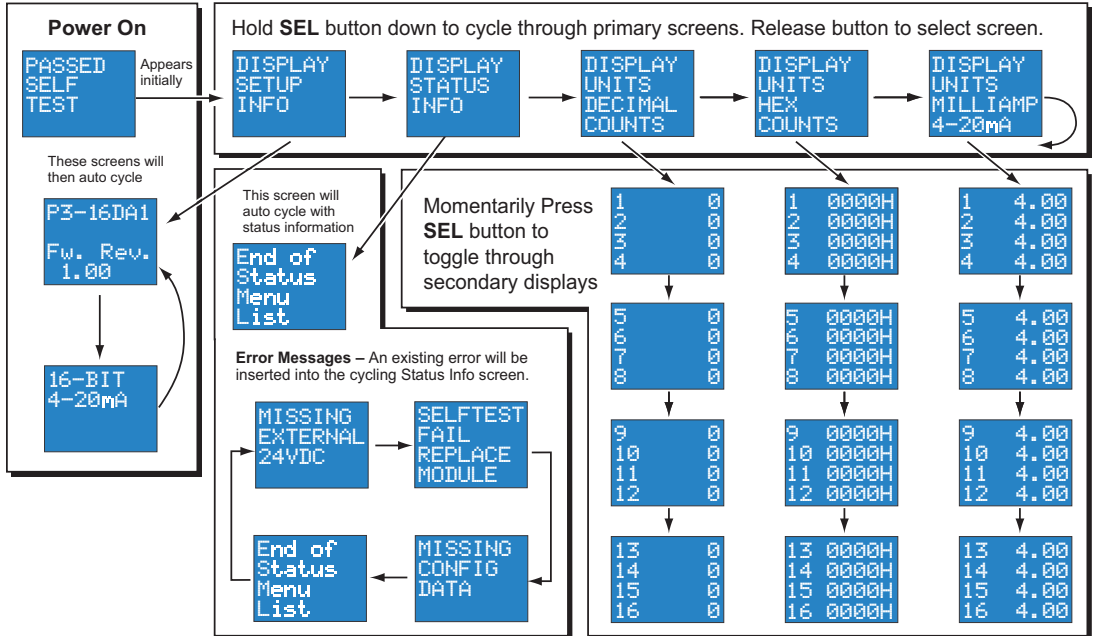

P3-16DA-2 Analog Output

The P3-16DA-2 Voltage Analog Output Module provides sixteen channels of $\pm 10\text{VDC}$ outputs.

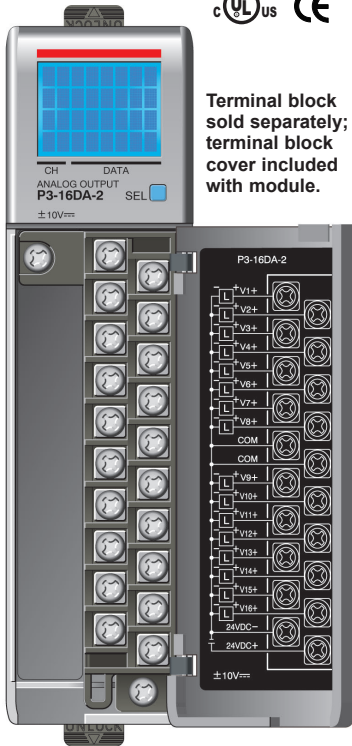

Terminal block sold separately; terminal block cover included with module.

Output Specifications

Output Channels	16
Module Signal Output Range	$\pm 10\text{VDC}$
Output Signal Resolution	16-bit
Resolution Value of LSB (least significant bit)	$\pm 10\text{V} = 305\mu\text{V}/\text{count}$ 1 LSB = 1 count
Data Range	-32768 to +32767
Output type (sourcing/sinking)	Voltage (10mA max current)
Output Value in Fault Mode	0V
Output Impedance	0.2 Ω typical
Load Impedance	$\leq 1000\Omega$
Maximum Capacitive Load	0.01 μF maximum
Allowed Load Type	Grounded
Maximum Inaccuracy	0.1% of range (including temperature drift)
Maximum Full Scale Calibration Error (not including offset error)	$\pm 0.025\%$ of range maximum
Maximum Offset Calibration Error	$\pm 0.025\%$ of range maximum
Accuracy vs. Temperature	$\pm 25 \text{ ppm}/^\circ\text{C}$ maximum f.s. calibration change ($\pm 0.0025\%$ of range / $^\circ\text{C}$)
Max Crosstalk	-96dB, 1 LSB
Linearity Error (end to end)	± 16 LSB maximum ($\pm 0.025\%$ of full scale) Monotonic with no missing codes
Output Stability and Repeatability	± 10 LSB after 10 min. warm-up (typical)
Output Ripple	0.05% of full scale
Output Settling Time	0.3 ms max, 5 μs min (full scale change)
All Channel Update Rate	0.6 ms
Maximum Continuous Overload	Outputs current limited to 40mA typical Continuous overloads on multiple outputs can damage the module.
Type of Output Protection	0.1 μF Transient Suppressor
External DC Power Required	24VDC (-20% / + 25%), 252mA

We recommend using prewired ZIPLink cables and connection modules. See Chapter 5.

Terminal block cover included. If you wish to hand-wire your module, a removable terminal block is sold separately. Order part number P3-RTB.



P3-16DA-2 Analog Output (continued)

General Specifications	
Operating Temperature	0° to 60°C (32° to 140°F),
Storage Temperature	-20° to 70°C (-4° to 158°F)
Humidity	5 to 95% (non-condensing)
Environmental Air	No corrosive gases permitted
Vibration	IEC60068-2-6 (Test Fc)
Shock	IEC60068-2-27 (Test Ea)
Field to Logic Side Isolation	1800VAC applied for 1s
Insulation Resistance	>10MΩ @ 500VDC
Heat Dissipation	6.4 W
Enclosure Type	Open equipment
Module Keying to Backplane	Electronic
Module Location	Any I/O slot in any local, expansion, or remote base in a Productivity3000® system.
Field Wiring	Removable terminal block (not included). Use ZIPLink wiring system or optional terminal block. See Chapter 5.
Terminal Type (not included)	20-position removable terminal block
Weight	105g (3.73 oz)
Agency Approvals	UL508 and UL1604 (Certified for Canada and USA) CE (EN61131-2*) This equipment is suitable for use in Class I, Division 2/Zone 2, Groups A, B, C, and D or non-hazardous locations only.

*Meets EMC and Safety requirements. See the Declaration of Conformity for details.

WARNING: Explosion hazard – Substitution of components may impair suitability for Class I, Division 2.

Removable Terminal Block Specifications	
Number of Positions	20 screw terminals
Wire Range	22–14 AWG (0.324 to 2.08 sq. mm) Solid / stranded conductor 3/64 in. (1.2 mm) insulation maximum USE COPPER CONDUCTORS , 60°C or equivalent.
Screw Driver Width	1/4 inch (6.5 mm) maximum
Screw Size	M3 size
Screw Torque	Field terminals: 7–9 in./lb (0.882–1.02 N·m) Self-jacking screws: 2.7–3.6 in./lb (0.3–0.4 N·m). Do not over-tighten screws when installing terminal block.

P3-16DA-2 Analog Output (continued)

Wiring Diagrams

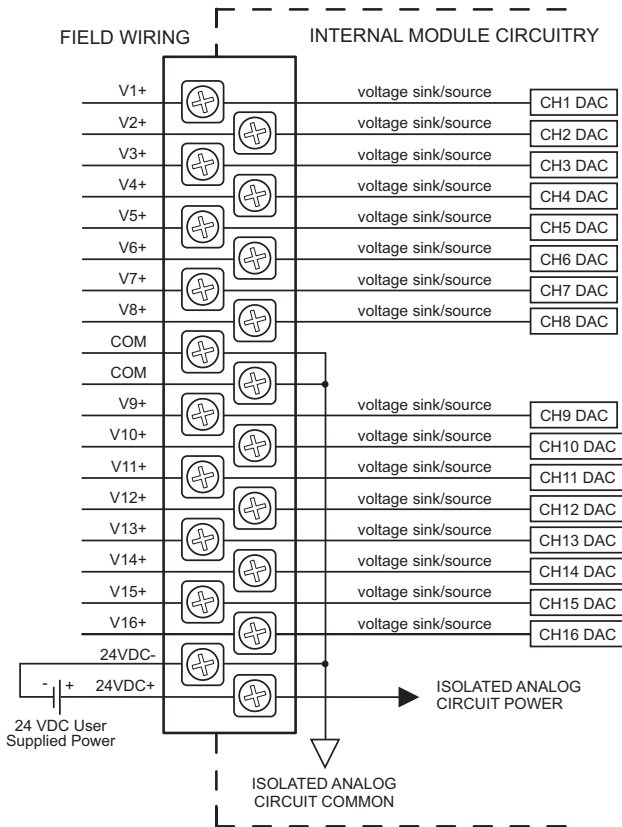

Voltage Output Circuits

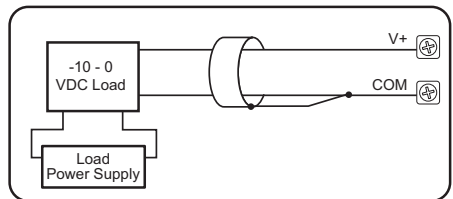
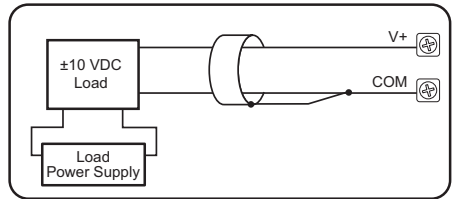
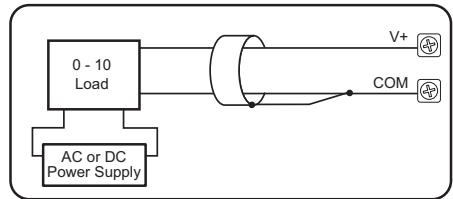

P3-16DA-2 Analog Output (continued)

Module Configuration

Using the Hardware Configuration tool in the Productivity Suite programming software, drag and drop the P3-16DA-2 module into the base configuration.

Select *Automatic Module Verification* or *No Verification and Enable Hot Swap* and *Stop Mode Values*. If desired, assign a *User Tagname* to each output point (channel) selected and to each *Status Bit Item*.

16 Channel 16 Bit Voltage Analog Out

Automatic Module Verification
 No Verification and Enable Hot Swap

Point	User Tagname	Stop Mode Value
1	AOS32-0.3.11.1	0
2	AOS32-0.3.11.2	0
3	AOS32-0.3.11.3	0
4	AOS32-0.3.11.4	0
5	AOS32-0.3.11.5	0
6	AOS32-0.3.11.6	0
7	AOS32-0.3.11.7	0
8	AOS32-0.3.11.8	0

Status Bit Item	User Tagname
Module Failed	MST-0.3.11.25
Missing 24V	MST-0.3.11.26

P3-16DA-2 Analog Output (continued)

LCD Panel Display

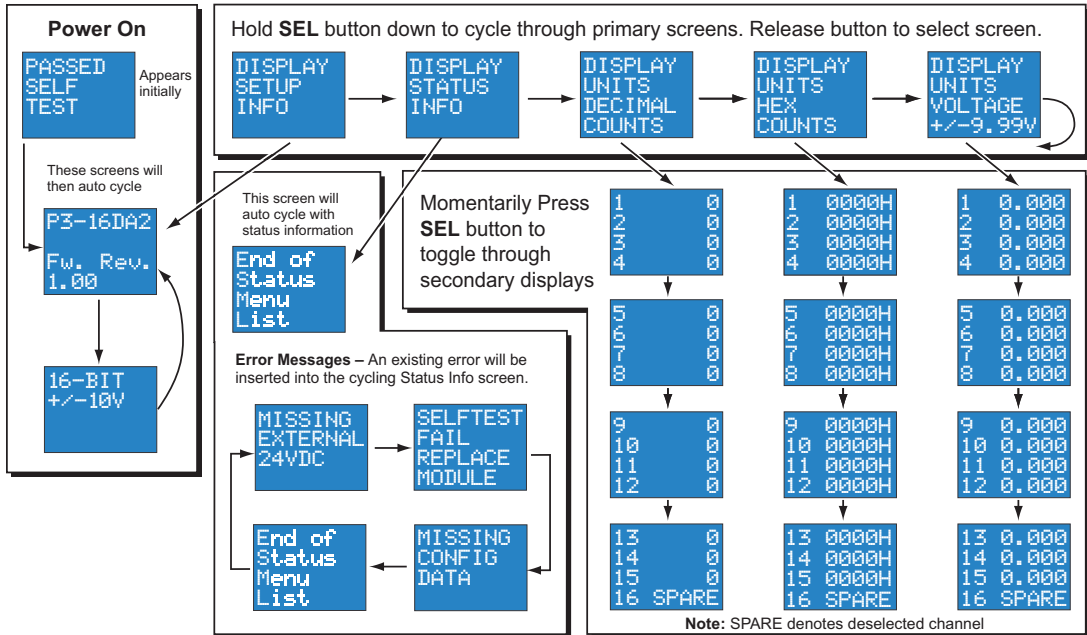

P3-8AD4DA-1 Analog Input/Output

The P3-8AD4DA-1 Current Analog Input/Output Module provides eight channels of current sinking 0–20 mA inputs and four channels of current sourcing 4–20 mA outputs.

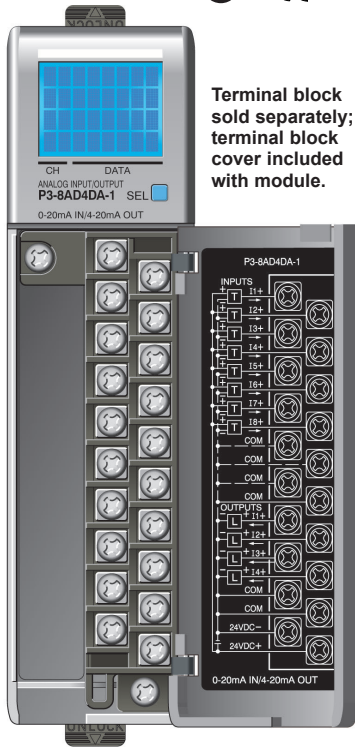

Terminal block sold separately; terminal block cover included with module.

Input Specifications

Input channels	8 (1 common)
Module Signal Input Range	0–20 mA
Signal Resolution	12–16 bit, depending on Input Resolution
Input Resolution & Update Rate <i>See Note 1</i>	Fine: 7.1 ms, 0.305 μ A, 16 bit Medium: 1.78 ms, 1.22 μ A, 14 bit Coarse: 444 μ s, 4.88 μ A, 12 bit
Data Range	0-65535 counts
Input Type	Single Ended (one common)
Maximum Continuous Overload	\pm 31mA
Input Impedance	250 Ω \pm 0.1% $\frac{1}{2}$ W
Hardware Filter Characteristics	Low pass 1st order, -3dB @ 48Hz
All Channel Update Rate <i>See Note 2</i>	Fine: 56.8 ms Medium: 14.24 ms Coarse: 3.55 ms
All Channel Update Rate	56.8 ms
Open Circuit Detection Time	Zero reading within 1s
Conversion Method	Successive approximation
Accuracy vs. Temperature	\pm 15PPM / $^{\circ}$ C maximum
Maximum Inaccuracy	0.1% of range
Linearity Error (end to end)	0.015% of range maximum Monotonic with no missing codes
Input Stability and Repeatability	\pm 0.015% of range (after 10 min. warm up)
Full Scale Calibration Error (not including offset)	\pm 0.05% of range maximum
Offset Calibration Error	\pm 0.005% of range maximum
Maximum Crosstalk	-96dB \pm 1–0.015% of full scale maximum
Recommended Fuse (external)	Edison S500-32-R, 0.032A fuse
External DC Power Required	24VDC (-20% / + 25%), 183mA maximum

Note 1: The Input Resolution of Fine returns 16 bit resolution. Medium and Coarse are 14 and 12 bit respectively. The 12 and 14 bit input values are scaled to 0-65535.

Note 2: Valid when all channels are set for the same Input Resolution.

We recommend using prewired ZIPLink cables and connection modules. See Chapter 5. Terminal block cover included. If you wish to hand-wire your module, a removable terminal block is sold separately. Order part number P3-RTB.



P3-8AD4DA-1 Analog Input/Output (continued)

Output Specifications	
Outputs per module	4 (1 common)
Module signal output range	4–20 mA
Output Signal resolution	16-bit
Resolution Value of LSB (least significant bit)	0.244 μ A/count 1 LSB = 1 count
Data Range	0–65535 counts
Output Type	Current sourcing, 20mA max
Output Value in Fault Mode	\leq 4mA
Load Impedance (Minimum Ext. Power Supply)	0–480 Ω (19.2 VDC) 0–600 Ω (21.6 VDC) 0–715 Ω (24.0 VDC) 0–840 Ω (26.4 VDC) 0–1010 Ω (30.0 VDC)
Maximum Inductive Load	1mH
Allowed Load Type	Grounded
Maximum Inaccuracy	\pm 0.1% of range
Maximum Full Scale Calibration Error (not including offset error)	\pm 0.065% of full scale
Maximum Offset Calibration Error	\pm 0.065% of full scale
Accuracy vs. Temperature	\pm 15ppm/ $^{\circ}$ C maximum full scale calibration change (\pm 0.025% of range / $^{\circ}$ C)
Maximum Crosstalk	-96dB
Linearity Error (end to end)	\pm 0.015% of range maximum Monotonic with no missing codes
Output Stability and Repeatability	\pm 0.15% after 10 min. warm-up typical
Output Ripple	0.01% of Full Scale at 50/60 Hz
Output Settling Time	Rising Time 200 μ s Falling Time 135 μ s (full scale change)
All Channel Update Rate	3.55 ms
Maximum Continuous Overload	Outputs open circuit protected
Type of Output Protection	Electronically current limited to 20mA or less
Output Signal (power-up, -down)	\leq 4mA

Removable Terminal Block Specifications	
Number of Positions	20 screw terminals
Wire Range	22–14 AWG (0.324 to 2.08 sq. mm) Solid / stranded conductor 3/64 in. (1.2 mm) insulation maximum USE COPPER CONDUCTORS , 60 $^{\circ}$ C or equivalent.
Screw Driver Width	1/4 inch (6.5 mm) maximum
Screw Size	M3 size
Screw Torque	Field terminals: 7–9 in./lb (0.882–1.02 N·m) Self-jacking screws: 2.7–3.6 in./lb (0.3–0.4 N·m). Do not over-tighten screws when installing terminal block.

P3-8AD4DA-1 Analog Input/Output (continued)

General Specifications	
Operating Temperature	0° to 60°C (32° to 140°F),
Storage Temperature	-20° to 70°C (-4° to 158°F)
Humidity	5 to 95% (non-condensing)
Environmental Air	No corrosive gases permitted
Vibration	IEC60068-2-6 (Test Fc)
Shock	IEC60068-2-27 (Test Ea)
Field to Logic Side Isolation	1800VAC applied for 1s
Insulation Resistance	>10MV @ 500VDC
Heat Dissipation	3.8 W
Enclosure Type	Open equipment
Module Keying to Backplane	Electronic
Module Location	Any I/O slot in any local, expansion, or remote base in a Productivity3000® system.
Field Wiring	Removable terminal block (not included). Use ZIPLink wiring system or optional terminal block. See Chapter 5.
Terminal Type (not included)	20-position removable terminal block
Weight	106.9g (3.76 oz)
Agency Approvals	UL508 file E157382, Canada & USA UL1604 file E200031, Canada & USA CE (EN61131-2*) This equipment is suitable for use in Class 1, Division 2, Groups A, B, C and D or non-hazardous locations only.

*Meets EMC and Safety requirements. See the Declaration of Conformity for details.

WARNING: Explosion hazard – Substitution of components may impair suitability for Class I, Division 2.

P3-8AD4DA-1 Analog Input/Output (continued)

Wiring Diagrams

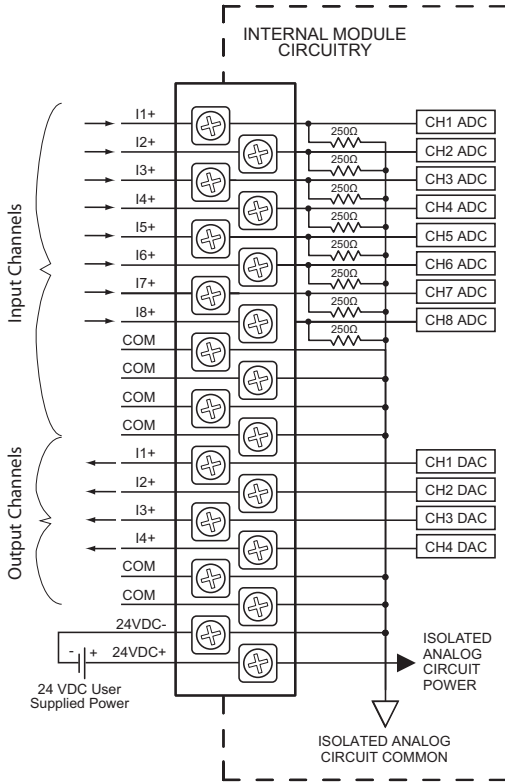

Note: This module includes input and output channels. Before connecting field wiring, verify that you are connecting to the appropriate terminals.

Current Input Circuits

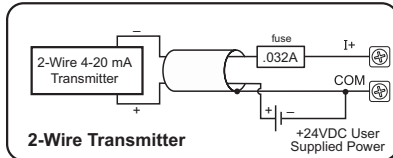

An Edison S500-32-R 0.032A fast-acting fuse is recommended for all 4-20 mA current loops.

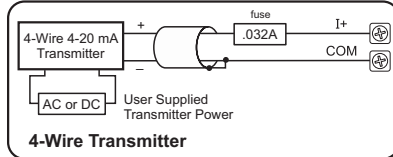
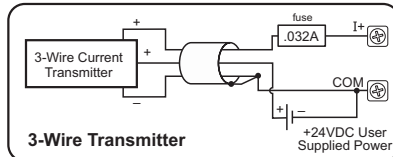

Note: Do not connect both ends of shield.

Current Output Circuits

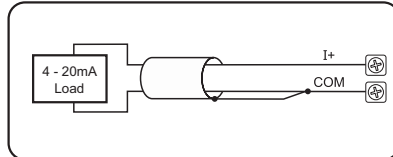

Note: Shield is connected to common at the source device.

P3-8AD4DA-1 Analog Input/Output (continued)

Module Configuration

Using the Hardware Configuration tool in the Productivity Suite programming software, drag and drop the P3-8AD4DA-1 module into the base configuration.

Select *Automatic Module Verification* or *No Verification and Enable Hot Swap*. Also specify *Input Resolution* for inputs and *Stop Mode Value* for outputs. If desired, assign a *User Tagname* to each input and output point (channel) selected and to each *Status Bit Item*.

P3-8AD4DA-1

8 Channel 16 Bit Current Sink In &
4 Channel 16 Bit Current Source Out

Automatic Module Verification
 No Verification and Enable Hot Swap

Point	Input User Tagname	Input Ch. Select	Input Resolution	Point	Output User Tagname	Stop Mode Value
1	AI532-0.4.1.1	<input checked="" type="checkbox"/>	Fine	1	AOS32-0.4.1.1	0
2	AI532-0.4.1.2	<input checked="" type="checkbox"/>	Fine	2	AOS32-0.4.1.2	0
3	AI532-0.4.1.3	<input checked="" type="checkbox"/>	Fine	3	AOS32-0.4.1.3	0
4	AI532-0.4.1.4	<input checked="" type="checkbox"/>	Fine		AOS32-0.4.1.4	0
5	AI532-0.4.1.5	<input checked="" type="checkbox"/>	Fine			
6	AI532-0.4.1.6	<input checked="" type="checkbox"/>	Fine			
7	AI532-0.4.1.7	<input checked="" type="checkbox"/>	Fine			
8	AI532-0.4.1.8	<input checked="" type="checkbox"/>	Fine			

Status Bit Item	User Tagname
Module Failed	MST-0.4.1.25
Missing 24V	MST-0.4.1.26
Under Range Error (ch1)	MST-0.4.1.57
Under Range Error (ch2)	MST-0.4.1.58
Under Range Error (ch3)	MST-0.4.1.59
Under Range Error (ch4)	MST-0.4.1.60
Under Range Error (ch5)	MST-0.4.1.61
Under Range Error (ch6)	MST-0.4.1.62

P3-8AD4DA-1 Analog Input/Output (continued)

LCD Panel Display

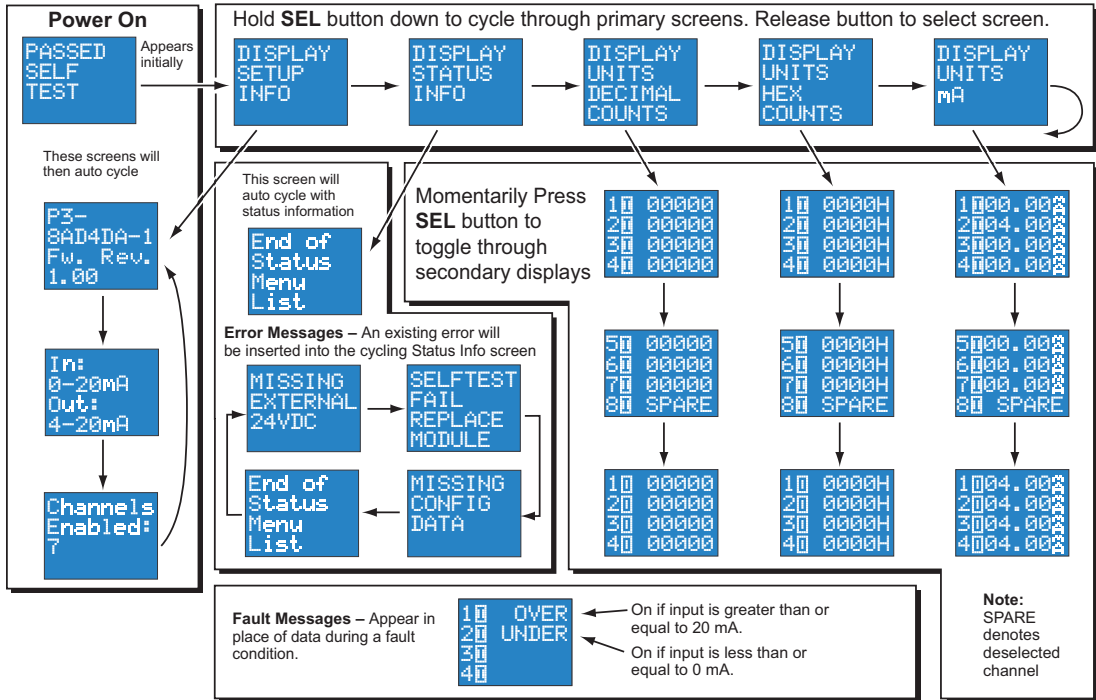

P3-8AD4DA-2 Analog Input/Output

The P3-8AD4DA-2 Voltage Analog Input/Output Module provides eight channels of 0–5 VDC and 0–10 VDC inputs and four channels of 0–5 VDC and 0–10 VDC outputs.



Terminal block sold separately; terminal block cover included with module.

Input Specifications	
Input channels	8 inputs (1 common)
Input ranges	0–5V, 0–10V
Signal resolution	12–16 bit, depending on Input Resolution
0-5V Input Resolution & Update Rate <i>See Note 1</i>	Fine: 7.1ms, 76µV, 16 bit Medium: 1.78 ms, 305µV, 14 bit Coarse: 444µs, 1.22 mV, 12 bit
0-10V Input Resolution & Update Rate <i>See Note 1</i>	Fine: 7.1 ms, 152µV, 16 bit Medium: 1.78 ms, 610µV, 14 bit Coarse: 444µs, 2.44 mV, 12 bit
Data Range	0–65535 counts
Maximum continuous overload	±100V, voltage input
Input impedance	1MV (± 10%) voltage input
Hardware Filter Characteristics	Low pass 1st order, -3dB @ 80Hz
All Channel Update Rate <i>See Note 2</i>	Fine: 56.8 ms Medium: 14.24 ms Coarse: 3.55 ms
Conversion Method	Successive approximation
Accuracy vs. Temperature	±15PPM / °C Maximum
Maximum Inaccuracy	0.1% of range
Linearity Error (end to end)	±0.015% of range maximum Monotonic with no missing codes
Input Stability and Repeatability	±0.025% of range (after 10 min. warm up)
Full Scale Calibration Error (minus offset)	±0.05% of range maximum
Offset Calibration Error	±0.05% of range maximum
Max Crosstalk	-96dB
External DC Power Required	24VDC (-20% / +25%), 90mA maximum

Note 1: The Input Resolution of Fine returns 16 bit resolution. Medium and Coarse are 14 and 12 bit respectively. The 12 and 14 bit input values are scaled to 0-65535.

Note 2: Valid when all channels are set for the same Input Resolution.

We recommend using prewired ZIPLink cables and connection modules. See Chapter 5.

Terminal block cover included. If you wish to hand-wire your module, a removable terminal block is sold separately. Order part number P3-RTB.



P3-8AD4DA-2 Analog Input/Output (continued)

Output Specifications	
Output channels	4 (1 common)
Output ranges	0–10V, 0–5V
Output Signal resolution	16-bit
Resolution Value of LSB (least significant bit)	0–5V = 76 μ V/count 0–10V = 152 μ V/count 1 LSB = 1 count
Data Range	0–65535 counts
Output Type	Voltage sourcing/sinking at 10mA max.
Output Value in Fault Mode	0V
Load Impedance	\leq 1125 Ω
Maximum capacitive load	0.01 μ F maximum
Allowed Load Type	Grounded
Maximum Inaccuracy	0.1% of range
Maximum Full Scale Calibration Error (not including offset error)	\pm 0.065% of range maximum
Maximum Offset Calibration Error	\pm 0.065% of range maximum
Accuracy vs. Temperature	\pm 25ppm/ $^{\circ}$ C maximum full scale calibration change (\pm 0.0025% of range / $^{\circ}$ C)
Max Crosstalk	-96dB
Linearity Error (end to end)	0.015% of full scale Monotonic with no missing codes
Output Stability and Repeatability	\pm 0.015% after 10 min. warm-up typical
Output Ripple	0.01% of Full Scale at 50/60 Hz
Output Settling Time	0.5 ms max, 5 μ s min (full scale change)
All Channel Update Rate	5ms
Maximum Continuous Overload	Outputs current limited to 15mA typical
Type of Output Protection	15VDC peak output voltage
Output Signal (power-up, -down)	0V

Removable Terminal Block Specifications	
Number of Positions	20 screw terminals
Wire Range	22–14 AWG (0.324 to 2.08 sq. mm) Solid / stranded conductor 3/64 in. (1.2 mm) insulation maximum USE COPPER CONDUCTORS , 60 $^{\circ}$ C or equivalent.
Screw Driver Width	1/4 inch (6.5 mm) maximum
Screw Size	M3 size
Screw Torque	Field terminals: 7–9 in./lb (0.882–1.02 N·m) Self-jacking screws: 2.7–3.6 in./lb (0.3–0.4 N·m). Do not over-tighten screws when installing terminal block.

P3-8AD4DA-2 Analog Input/Output (continued)

General Specifications	
Operating Temperature	0° to 60°C (32° to 140°F),
Storage Temperature	-20° to 70°C (-4° to 158°F)
Humidity	5 to 95% (non-condensing)
Environmental Air	No corrosive gases permitted
Vibration	IEC60068-2-6 (Test Fc)
Shock	IEC60068-2-27 (Test Ea)
Field to Logic Side Isolation	1800VAC applied for 1s
Insulation Resistance	>10MΩ @ 500VDC
Heat Dissipation	2.5 W
Enclosure Type	Open equipment
Module Keying to Backplane	Electronic
Module Location	Any I/O slot in any local, expansion, or remote base in a Productivity3000® system.
Field Wiring	Removable terminal block (not included). Use ZIPLink wiring system or optional terminal block. See Chapter 5.
Terminal Type (not included)	20-position removable terminal block
Weight	105g (3.73 oz)
Agency Approvals	UL508 file E157382, Canada & USA UL1604 file E200031, Canada & USA CE (EN61131-2*) This equipment is suitable for use in Class 1, Division 2, Groups A, B, C and D or non-hazardous locations only.

*Meets EMC and Safety requirements. See the Declaration of Conformity for details.

WARNING: Explosion hazard – Substitution of components may impair suitability for Class I, Division 2.

P3-8AD4DA-2 Analog Input/Output (continued)

Wiring Diagrams

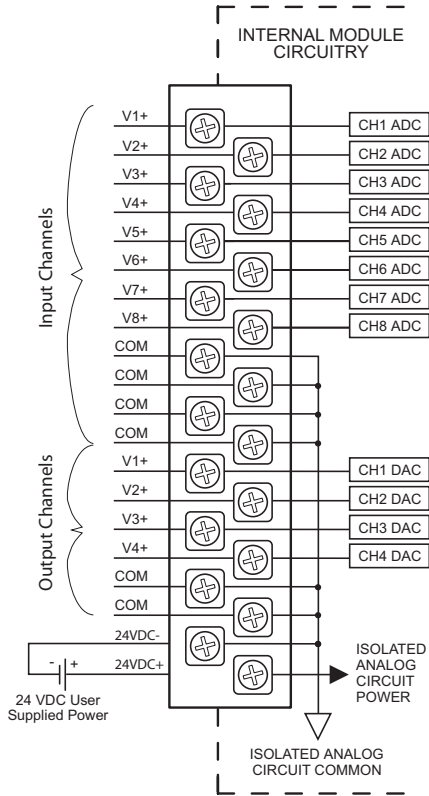

Voltage Input Circuits

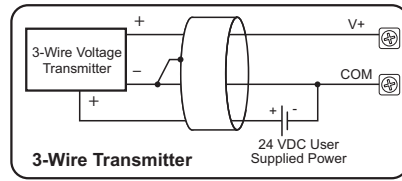
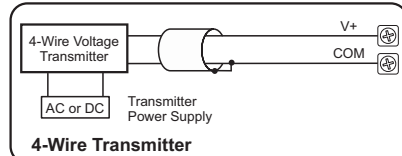

Voltage Output Circuits

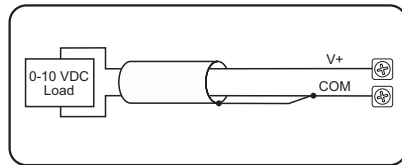
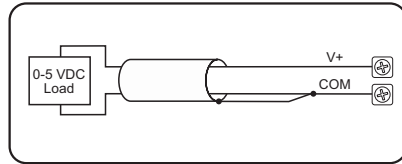

Note: This module includes input and output channels. Before connecting field wiring, verify that you are connecting to the appropriate terminals.

P3-8AD4DA-2 Analog Input/Output (continued)

Module Configuration

Using the Hardware Configuration tool in the Productivity Suite programming software, drag and drop the P3-8AD4DA-2 module into the base configuration.

Select *Automatic Module Verification* or *No Verification and Enable Hot Swap*. Also specify *Input Range* and *Input Resolution* for inputs along with *Output Range* and *Stop Mode Value* for outputs. If desired, assign a *User Tagname* to each input and output point (channel) selected and to each *Status Bit Item*.

8 Channel 16 Bit Voltage Sink In &
4 Channel 16 Bit Voltage Source Out

Automatic Module Verification
 No Verification and Enable Hot Swap

Point	Input User Tagname	Input Ch. Select	Input Range	Input Resolution
1	AI332-0.4.2.1	<input checked="" type="checkbox"/>	0-10 V	Fine
2	AI332-0.4.2.2	<input checked="" type="checkbox"/>	0-10 V	Fine
3	AI332-0.4.2.3	<input checked="" type="checkbox"/>	0-10 V	Fine
4	AI332-0.4.2.4	<input checked="" type="checkbox"/>	0-10 V	Fine
5	AI332-0.4.2.5	<input checked="" type="checkbox"/>	0-10 V	Fine
6	AI332-0.4.2.6	<input checked="" type="checkbox"/>	0-10 V	Fine
7	AI332-0.4.2.7	<input checked="" type="checkbox"/>	0-10 V	Fine
8	AI332-0.4.2.8	<input checked="" type="checkbox"/>	0-10 V	Fine

Point	Output User Tagname	Stop Mode Value
1	AO532-0.4.2.1	0
2	AO532-0.4.2.2	0
3	AO532-0.4.2.3	0
4	AO532-0.4.2.4	0

Output Range Selection: 0-5 V

Status Bit Item	User Tagname
Module Failed	MST-0.4.2.25
Missing 24V	MST-0.4.2.26
Under Range Error (ch1)	MST-0.4.2.57
Under Range Error (ch2)	MST-0.4.2.58
Under Range Error (ch3)	MST-0.4.2.59
Under Range Error (ch4)	MST-0.4.2.60
Under Range Error (ch5)	MST-0.4.2.61
Under Range Error (ch6)	MST-0.4.2.62

Monitor Module Info OK Cancel Help

P3-8AD4DA-2 Analog Input/Output (continued)

LCD Panel Display

