

GETTING STARTED!



CHAPTER 1

In This Chapter...

Introduction	1-2
Purpose of this Manual	1-2
About Getting Started.....	1-2
Online Help Files and Other Documentation	1-2
Technical Support.....	1-2
Conventions Used	1-3
Key Topics for Each Chapter.....	1-3
Before you begin.....	1-4
Productivity Suite System Requirements.....	1-5
Step 1: Install Programming Software.....	1-6
Step 2: Launch Programming Software	1-10
Online Help.....	1-11
Step 3: Install Hardware	1-12
Step 4: Apply Power to CPU.	1-15
Step 5: Establish PC to CPU Communications.....	1-16
Step 6: Open/Read Hardware Configuration.....	1-17
Step 7: Create a Project.....	1-19
Rung #1.....	1-19
Rung #2	1-23
Step 8: Save Project.....	1-25
Step 9: Write Project to CPU.....	1-26
Step 10: Place CPU in RUN Mode.....	1-27
Step 11: Test the Project Using Monitor Mode.....	1-28

Introduction

Purpose of this Manual

Thank you for purchasing the AutomationDirect Productivity3000® family of system control products. This hardware user manual provides information that will help you install, set up, program, troubleshoot, and maintain your Productivity3000 system. The manual includes information that is critical to the safety of the personnel who will install and use the controller and for safe operation of the machinery, processes, and equipment controlled by the Productivity3000 system.

The manual also includes important information about power and signal wiring, mounting of the CPU and its modules, and configuration of the CPU system.

About Getting Started

If you are familiar with Programmable Controllers in general, then following the simple steps in this first chapter may be all you require to start being productive using a Productivity3000 CPU system. After you have completed the steps, your Productivity3000 controller will be running the ladder logic project that you programmed.

Online Help Files and Other Documentation

The Productivity3000 programming software, Productivity Suite, is available as a download from our website.

See <http://www.aboutplcs.com/>

The Productivity Suite software includes searchable online help topics covering all aspects of the software, instruction set, module setup, and communications.

In addition an informative installation insert is included with each base, power supply, CPU, and I/O module packaging.

Technical Support

We strive to make our manuals the best in the industry. We rely on your feedback to let us know if we are reaching our goal. If you cannot find the solution to your particular application, or, if for any reason you need technical assistance, please call us at:

770-844-4200

Our technical support group will work with you to answer your questions. They are available Monday through Friday from 9:00 A.M. to 6:00 P.M. Eastern Time. We also encourage you to visit our web site where you can find technical and non-technical information about our products and our company.

<http://www.automationdirect.com>

Conventions Used



NOTE: When you see the "note pad" icon in the left-hand margin, the paragraph to its immediate right will be a special note. Notes represent information that may make your work quicker or more efficient. The word NOTE: in boldface will mark the beginning of the text.



WARNING: When you see the "exclamation point" icon in the left-hand margin, the paragraph to its immediate right will be a warning. This information could prevent injury, loss of property, or even death in extreme cases. Any warning in this manual should be regarded as critical information that should be read in its entirety. The word WARNING in boldface will mark the beginning of the text.

Key Topics for Each Chapter

The beginning of each chapter will list the key topics that can be found in that chapter.

Getting Started!

CHAPTER 1

In This Chapter...

Introduction	1-2
Purpose of this Manual	1-2
About Getting Started!.....	1-2
Supplemental Manuals and Other Help	1-2
Technical Support	1-2
Conventions Used	1-3

Before you begin...

It is recommended that the following items be available to make this short step-by-step introduction to the Productivity3000® CPU go smoothly.

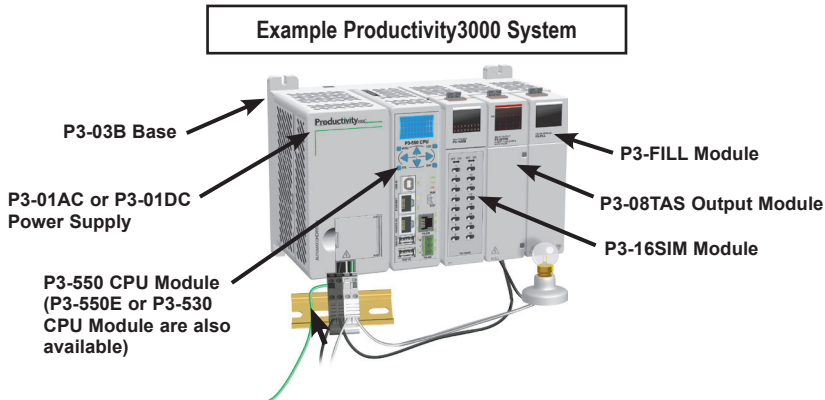

PC Running Windows OS



Not available from Automationdirect.com.

Productivity Suite Programming Software PS-PGMSW



Download software from our website at: www.productivityCPU.com

USB-A to USB-B Programming Cable (P3-550 only)



If using the P3-530(E) CPU, then use an Ethernet cable for programming. Refer to the help file for information on Ethernet communication set up procedures

Screwdriver TW-SD-VSL-1



Wire Strippers DN-WS



Hookup Wire



AC Power Cord



Not available from Automationdirect.com.

Productivity Suite System Requirements



Productivity Suite, a Windows-based programming software, is available as a FREE download at <http://www.automationdirect.com/support/software-downloads?itemcode=Productivity%20Suite> > Please check our website for current operating systems requirements.



NOTE: USB or Ethernet cable is also required for communications between PC and CPU.

Step 1: Install Programming Software



1. Download the latest version of the Productivity Suite Programming Software from the Automationdirect website, or insert the Productivity Suite Programming Software USB thumb drive into your PC USB port.
2. By default Productivity Suite will be saved in the "Download" folder as a ".zip" file.
 - Right Click on the ProSuite_xxx.zip file in the Download folder.
 - Choose "Extract All" from the drop-down menu. A popup box will open.
 - Select the "Browse" button and navigate to the folder where you prefer to store the program, or accept the default location.
 - Click on "Select Folder" button and in the next box choose "Extract".



NOTE: See the *Productivity Suite Installation* and *Productivity Suite Startup* topics for additional details if needed.

3. Navigate to the chosen folder and double click on the ProSuite ".exe" file.
4. The "Setup Wizard" window (shown below) will appear. Select Next.

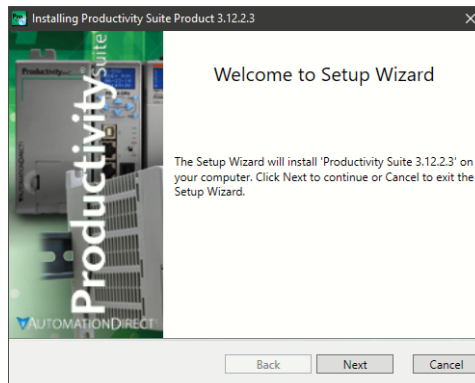

5. Carefully read the software license agreement. If you agree to the terms and conditions of this agreement, select the “I accept the terms of the License Agreement” and then the “Next” button.
6. The “Destination Folder” window will open next. The default location will appear in the text box: C:\Program Files\AutomationDirect\Productivity Suite <Software Version>. Should you desire a different folder choose:

- a. Browse: This option allows you to select another folder for installation.

If the installer detects a previous version of Productivity Suite on your PC, there is another option available with this window:

- b. Replace Existing Instance: This option allows you to uninstall the previous version of the software and install the new version in its place. If you check this option, select the version in the window that you want to delete. Click “Next” to continue.

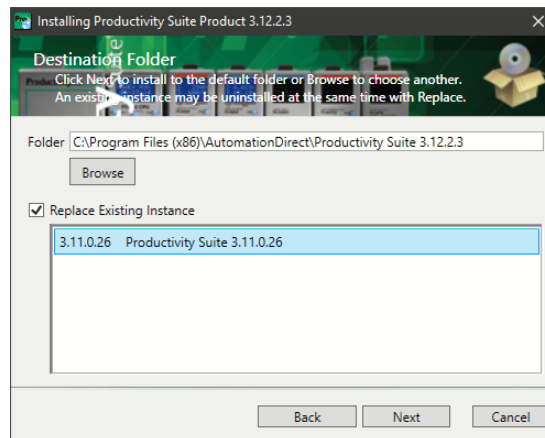
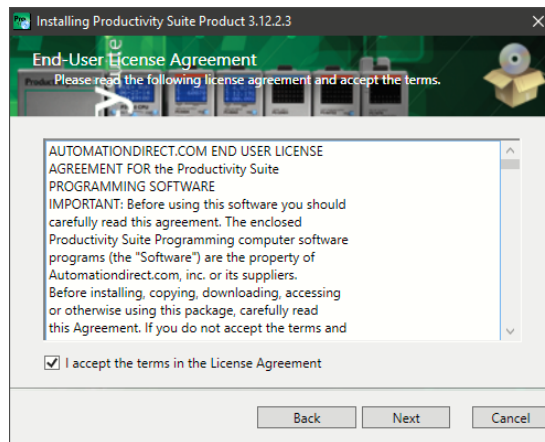

Chapter 1: Getting Started

7. Once you have selected the install folder or after deleting any previous instances, click "Install" to begin the installation.

A status window will appear displaying the status of the installation.

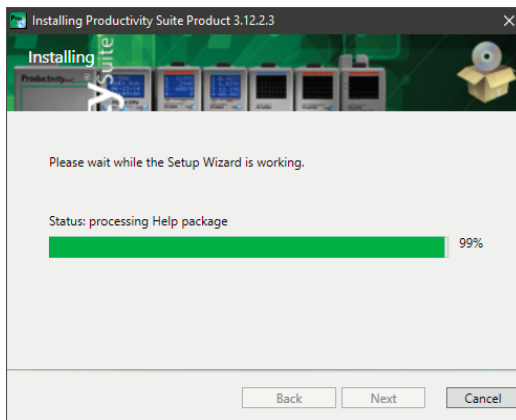
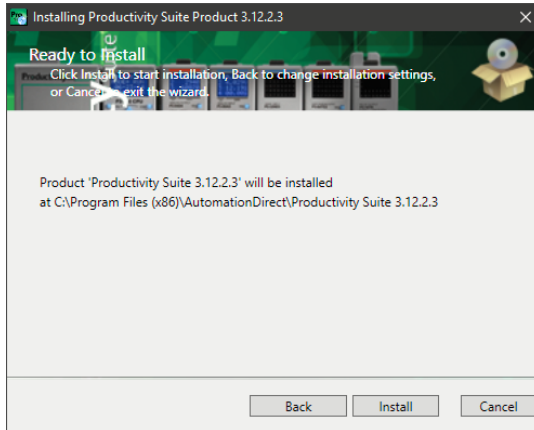

A shortcut icon will automatically be placed on the Desktop during installation.

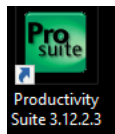

- The next screen to appear contains the Release Notes for this version of the Productivity Suite software. This is an opportunity to review the software version release notes. You may read these before selecting the "Next" button.
- The Installation is now complete. Select "Done".

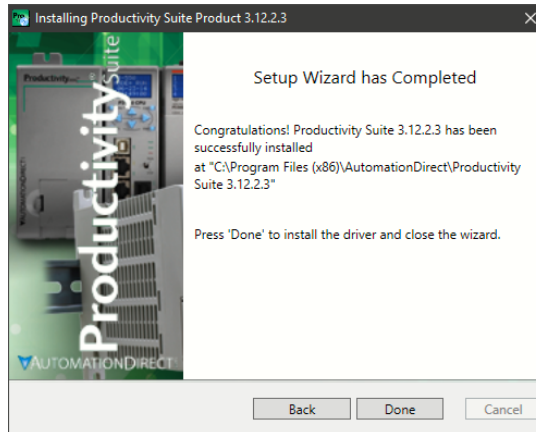
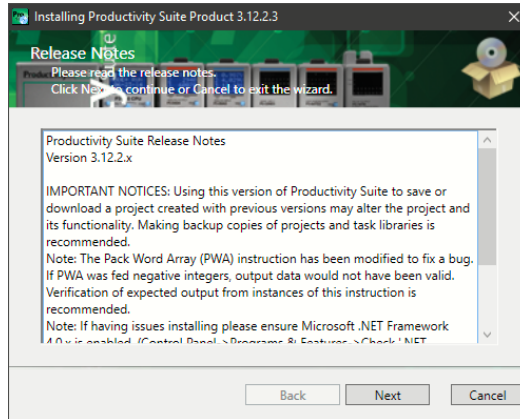

Step 2: Launch Programming Software

After installing the Productivity Suite Programming Software, PS-PGMSW, launch the software by double clicking the desktop Productivity Suite Icon. Or from the PC's 'Start' menu, select Productivity Suite x.x.x.x.

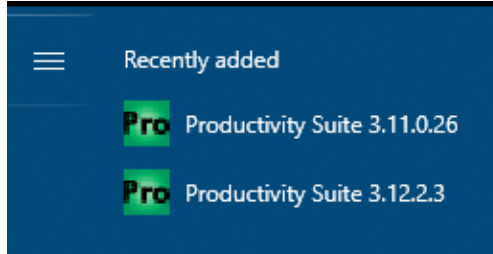

The Productivity Suite Programming Software will start up and display the Main Window as shown below.



NOTE: The recommended minimum screen size for the Productivity Suite Software is 1920 X 1080 pixels.

Click on the 'Start a New Project' in the Start Productivity dialog box to open a programming window.

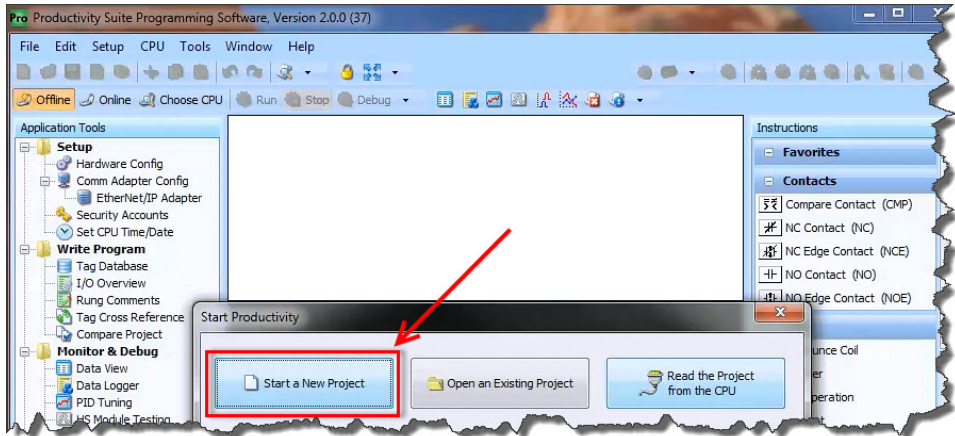

The Programming Window is divided into menus and toolbars that work together to make project development as simple as possible.

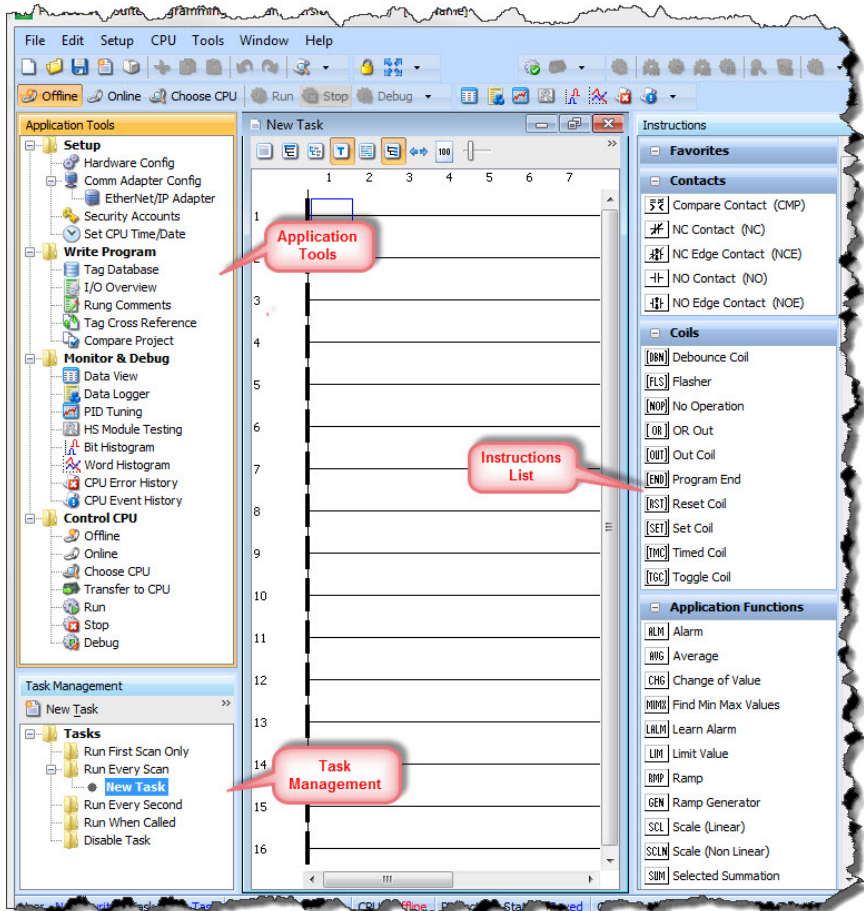

Online Help

It is essential that you use the Productivity Suite online Help to familiarize yourself with the software. Keep it open on your desktop and refer to it frequently as you build your system. Click on the toolbar Help button to open the Help file.

Step 3: Install Hardware

The Productivity3000® CPU system components snap together to form a configured CPU in minutes. See Chapter 5, Installation and Wiring, for more detailed hardware installation information, but these are the basic steps:

1. Install power supply in the base and engage locking tabs.

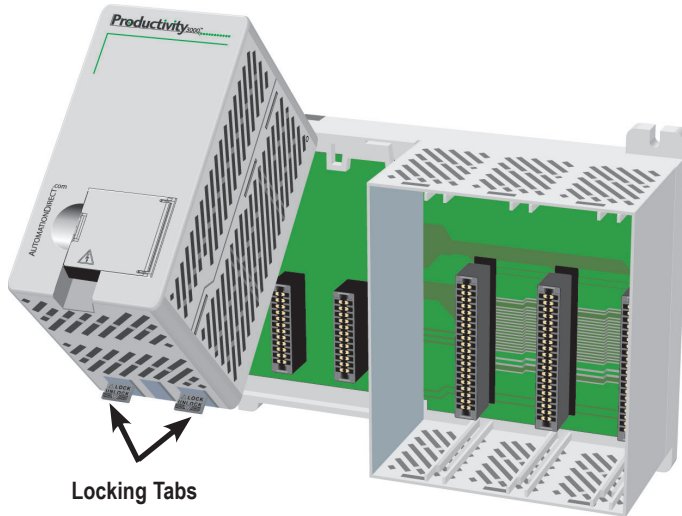

2. Install CPU in the base and engage locking tab.

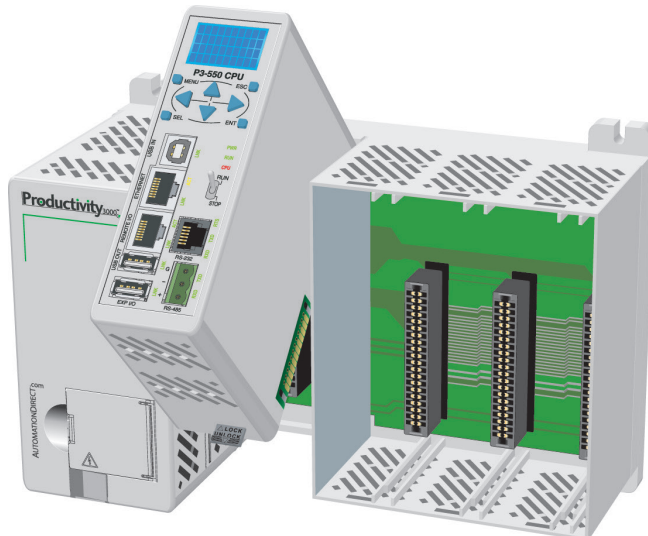

3. Install I/O Modules and engage locking tabs.

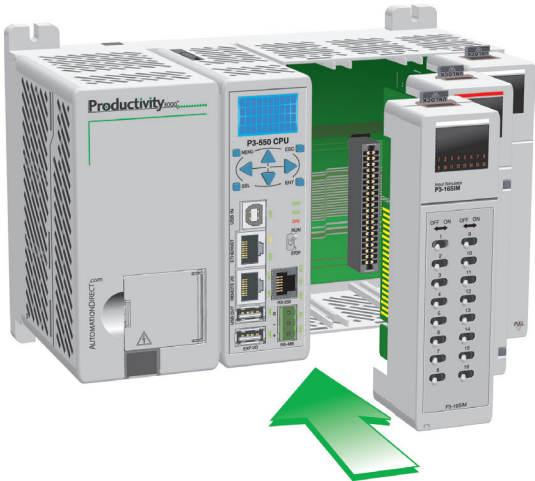

4. Connect appropriate wiring to power supply and I/O, a P3-01AC and P3-08TAS in this example.



In this case, The power supply and load are being connected to an AC current source.

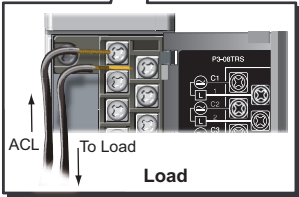
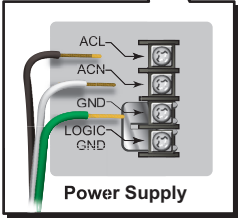

Chapter 1: Getting Started

5. Connect USB cable (P3-550 only). Use a standard USB cable with Type A and Type B connectors as shown below.

If using the P3-530 or P3-550E, connect a standard Ethernet cable from the PC to the CPU.

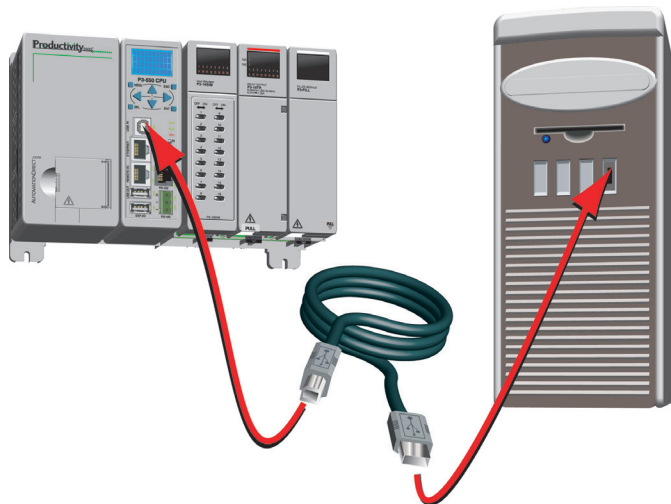

Step 4: Apply Power to CPU.

Ensure proper wiring has been made to the CPU and the correct voltage is available before applying power to the CPU. Once this is verified, apply power to the CPU. The CPU will perform a self evaluation and verification when power is applied. See Chapters 2 and 5 of this manual for more power supply and input wiring information.

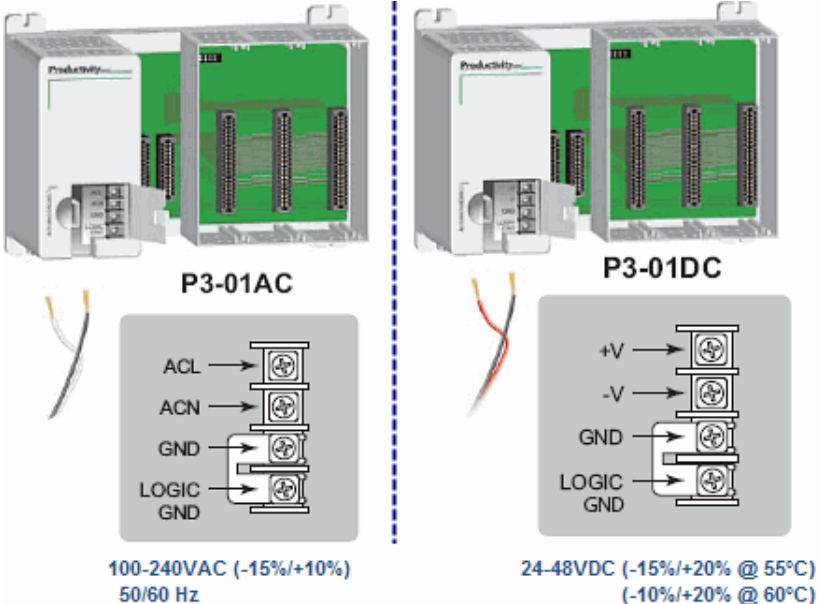

Step 5: Establish PC to CPU Communications

Select the Choose CPU Icon on the Control CPU Toolbar and the dialog shown below will appear.

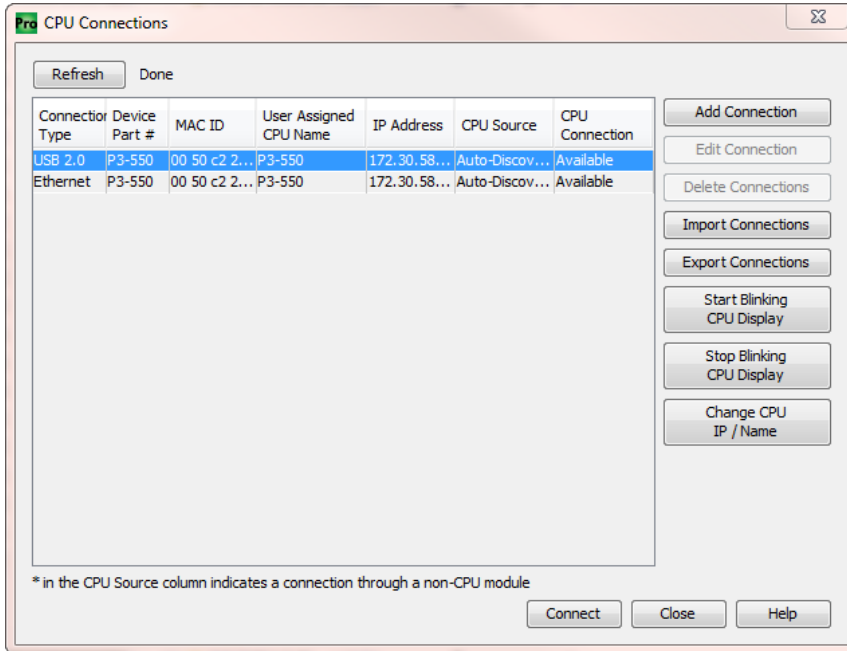

Highlight the CPU listed in the dialog box and select “Connect”.

When initially going Online with the CPU, a popup window will notify you of a project difference between the CPU and the PC. Select “No, Use PC Project”.

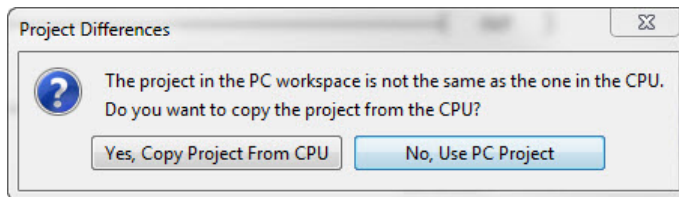

Step 6: Open/Read Hardware Configuration

Before we create a project we must configure the hardware so we'll have the input and output tags. With the CPU in STOP Mode, select Hardware Configuration under Application Tools and the following screen opens.

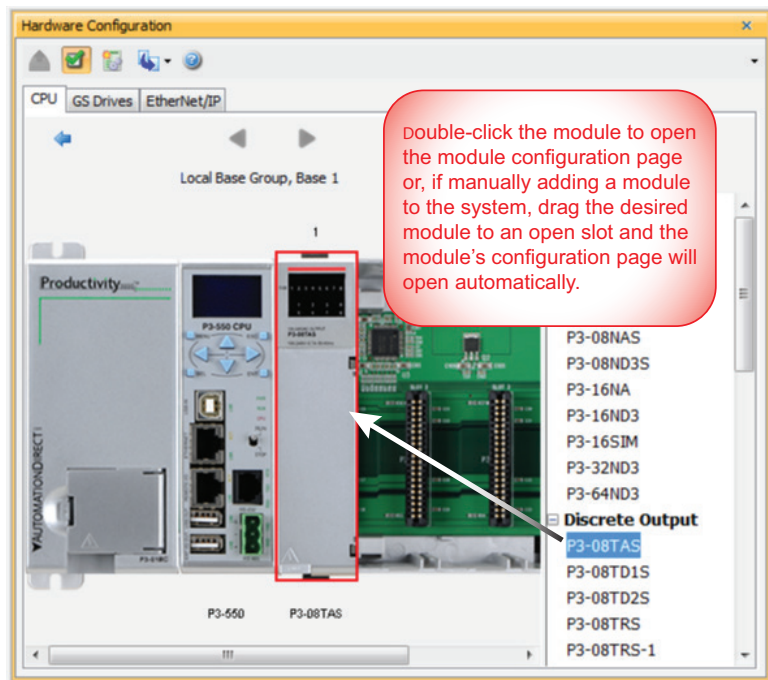
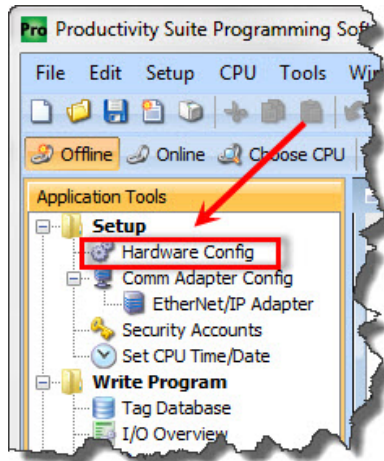

This screen shows the user tag names for all eight I/O points. Select OK.

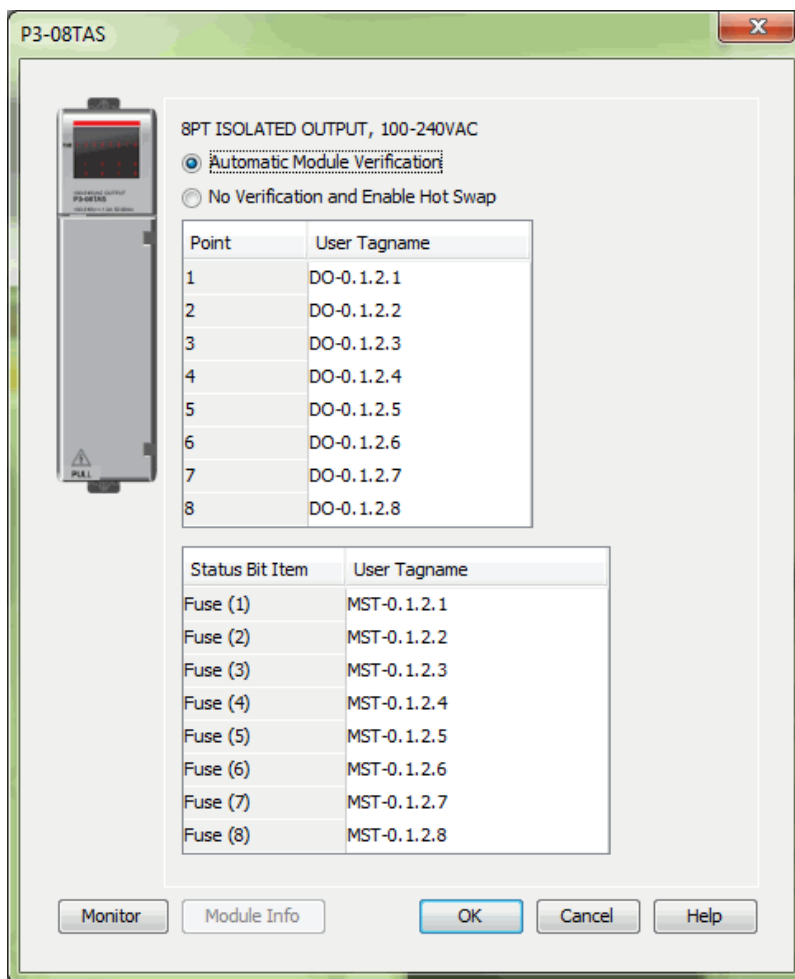

Step 7: Create a Project

We're going to start entering a simple example ladder logic program in the order that follows.

Rung #1

Place the box cursor on the END position on Rung #1 as shown below. From the Instructions List, scroll down to Counters/Timers and click & drag a Simple Timer (STMR) into the box. A Simple Timer (STMR) dialog box pops up.

1. Click on text box at Preset Value. Enter '300' (0.01 sec timebase) for a 3 second preset (T1_SP).
2. Enter 'T1_CURVAL' into the Current Value test box.

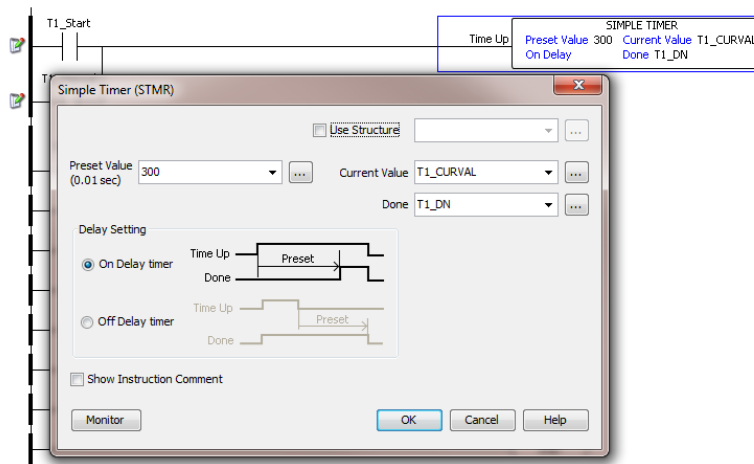

3. Enter 'T1_DN' into the Done text box.
4. Select OK.

The Define Tags dialog box opens. Select OK.

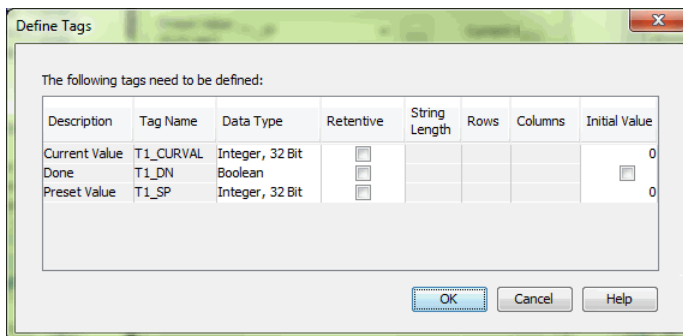

Chapter 1: Getting Started

Place the Box Cursor on the first position on Rung #1 as shown below. From the Instruction List, scroll to Contact and click & drag a Contact (NO) into the box. A NO Contact (NO) dialog box pops up.

1. Enter 'T1_Start' into the text box.
2. Select OK.

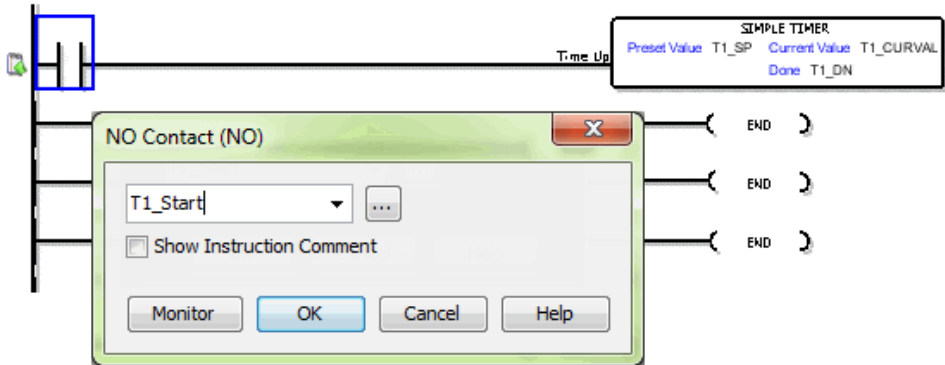

The Define Tags dialog box opens. Select OK.

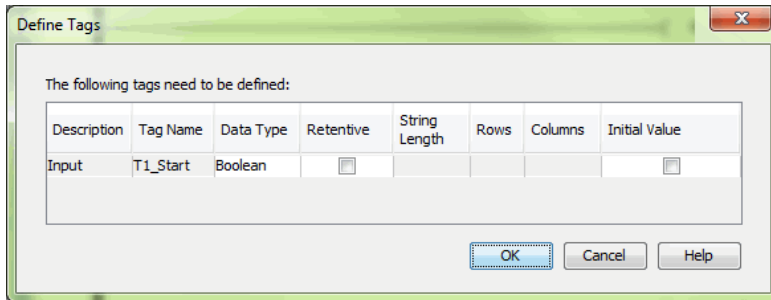

With the cursor in the position to the right of contact 'T1_Start', we are going to begin drawing a branch circuit. Under the Edit drop down menu, select Wire, then select Down. Notice that a wire has been added.

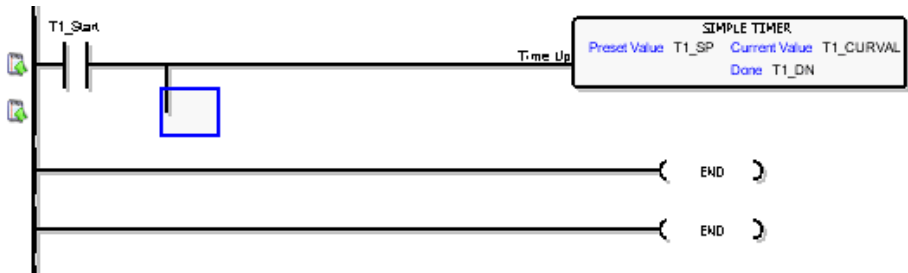
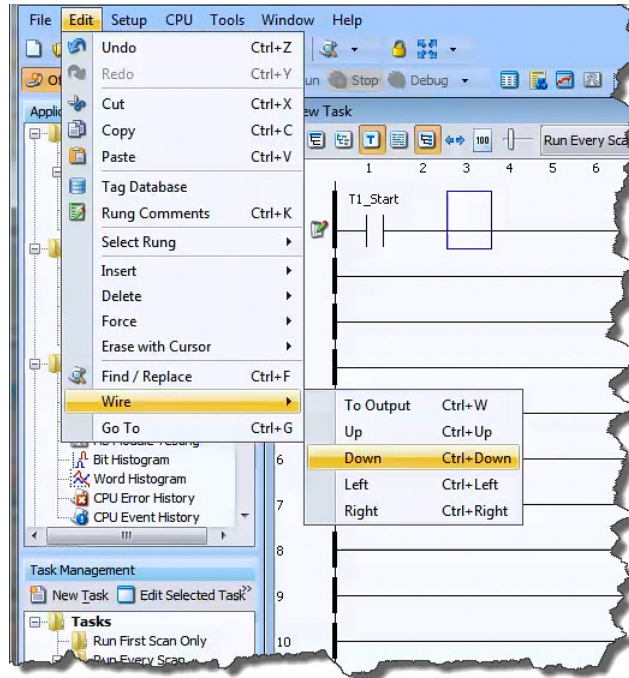

NOTE: There is a wire Erase With Cursor tool in the Edit drop down menu that is used to erase any lines that were created using the Wire tools.

Chapter 1: Getting Started

Next we'll draw a wire to the left. Under the Edit drop down menu, select Wire, then select Left.

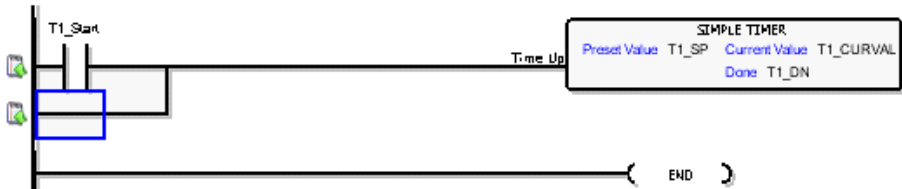

Next we'll add another normally-open contact. Place the box cursor on the first position on Rung #1.1. From the Instruction List click & drag a Contact (NO) into this box. A NO Contact (NO) dialog box pops up.

1. Enter 'T1_Manual' into the text box.
2. Select OK.

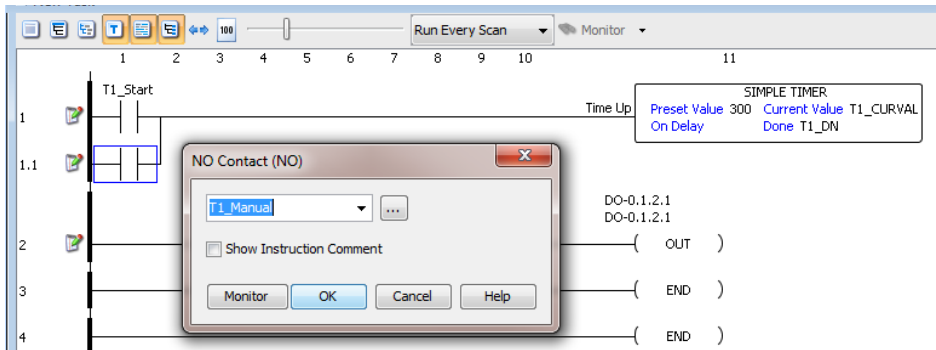

The Define Tags dialog box opens. Select OK.

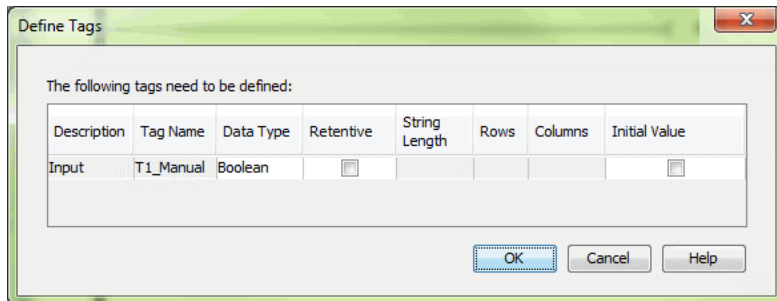

Rung #2

Next we'll add another normally-open contact at the start of rung 2. Click & drag a Contact (NO) into this box. A NO Contact (NO) dialog box pops up.

1. In the text box scroll down and select 'T1_DN'.
2. Select OK.

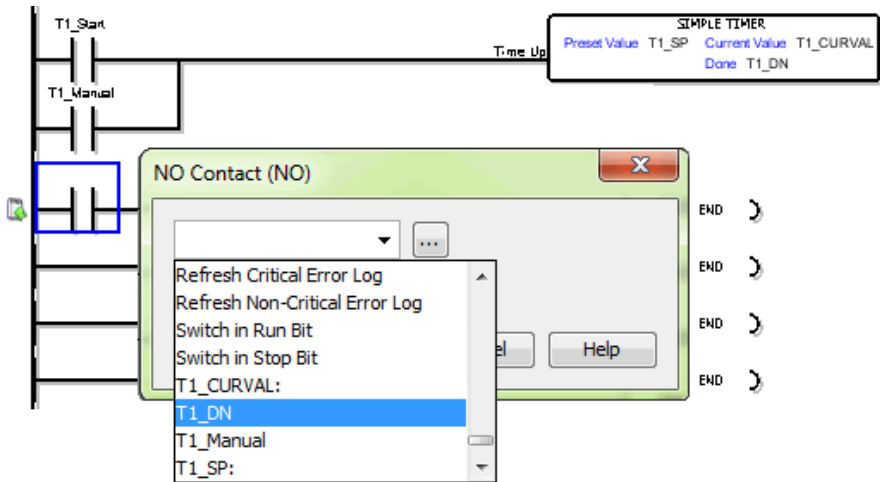

Next we'll add an Out coil at the end of the rung. Place the cursor at the end of the rung and from the Instructions list drag & drop an Out Coil (OUT). An Out Coil (OUT) dialog box pops up.

1. In the text box scroll down and select 'DO-0.1.2.1'.
2. Select OK.

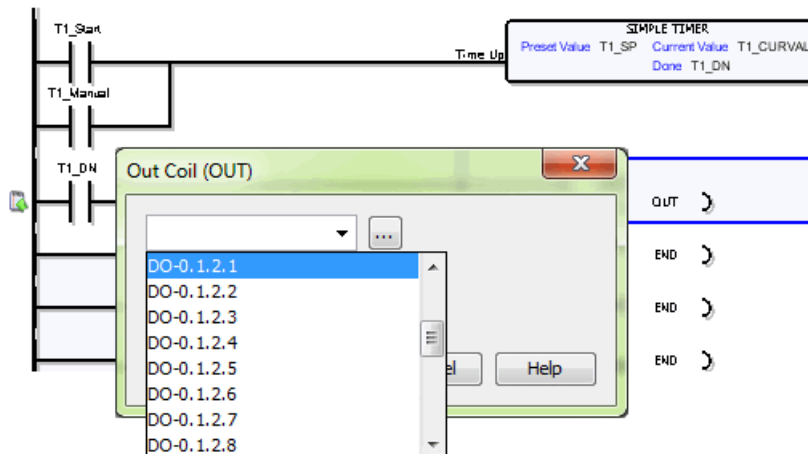

Chapter 1: Getting Started

The ladder program now looks like this. When either of the T1 contacts are energized, the timer starts. When it times out, contact T1_DN energizes and turns on the rung 2 output.

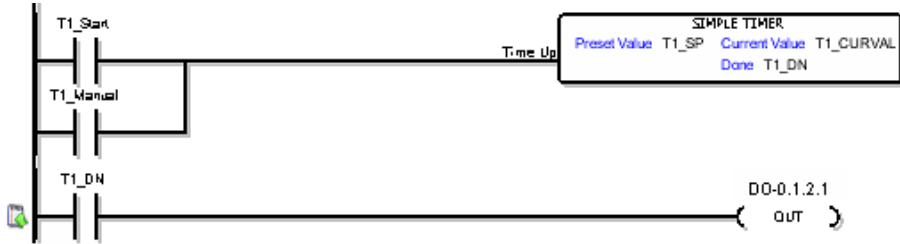

Step 8: Save Project

Save the project by opening the File drop down menu and selecting Save Project.

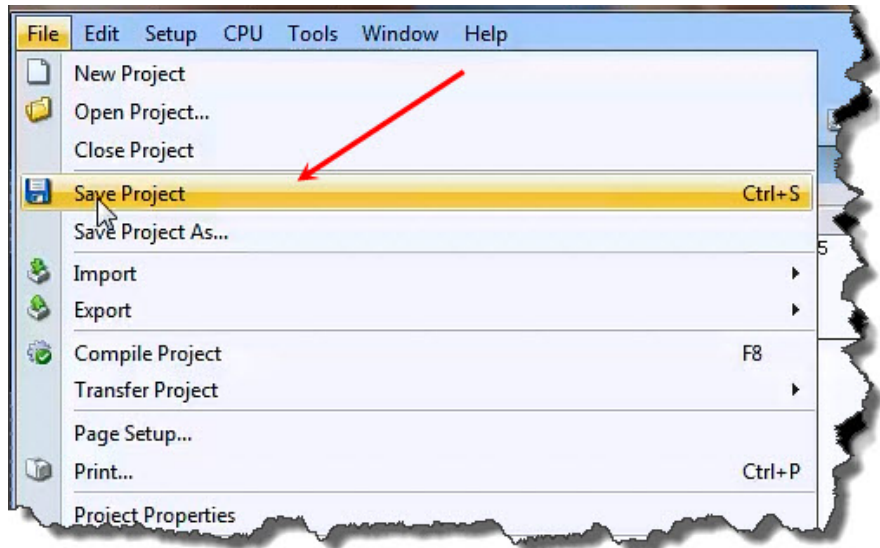

Step 9: Write Project to CPU

Next we will transfer the project to the CPU. Transfer Project is accessed by selecting Transfer Project from the File Menu of the Main Menu.

Select "To CPU" from the Transfer Project menu.

The project will then be Transferred to the CPU from the PC. During the transfer a status window will open displaying the process.

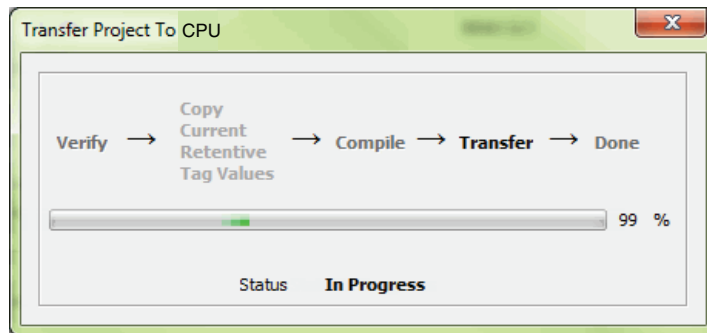
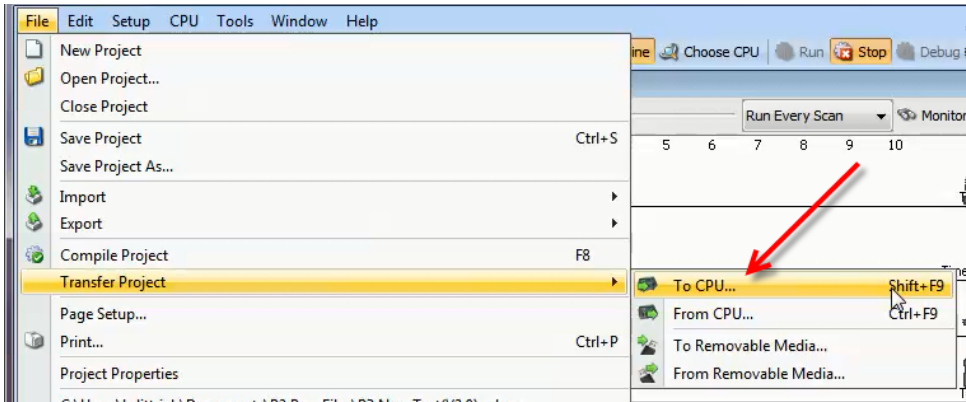

Step 10: Place CPU in RUN Mode

Next, verify the Run/Stop switch on the CPU is placed to the Run position and then place the CPU in RUN mode on the Control CPU Toolbar so the ladder logic program executes.

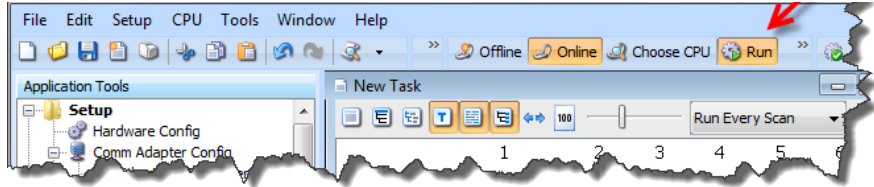

NOTE: If the Run/Stop switch on the CPU is in the Stop position, the Run button on the Control CPU Toolbar will be disabled.

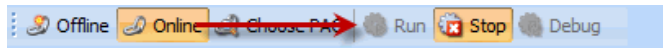

Step 11: Test the Project Using Monitor Mode

In this next step, use the Monitor Mode and Data View to test the ladder logic program. Select Monitor Mode from the top of the Ladder Logic screen to display the status of Boolean and Integer Tags.

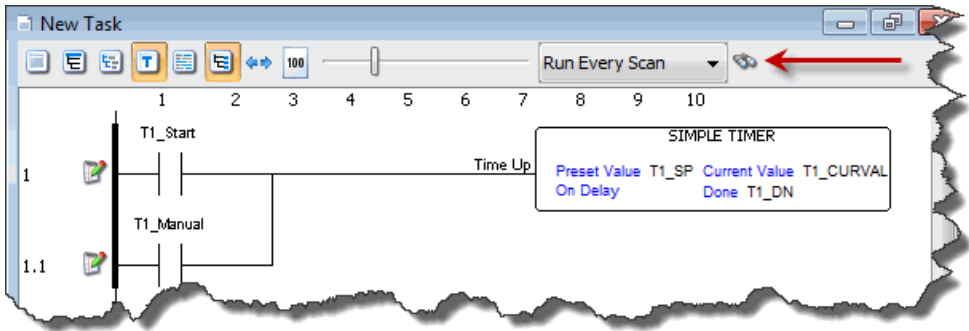

Using Data View, the Tag values can be viewed or manipulated for testing the project. The Data View window can be accessed by selecting Data View from the Tools Menu of the Main Menu.

For the Simple Timer Instruction, a Monitor button is provided that, when selected, will load the tags associated with the instruction into Data View.

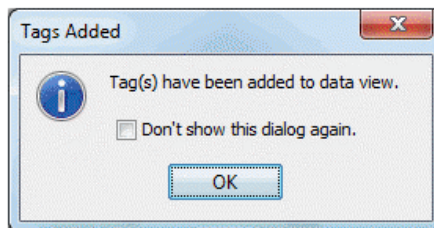
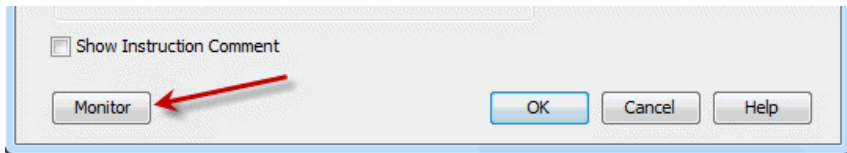

The tags will be placed in a separate Tab titled New Task - STMR as seen below.

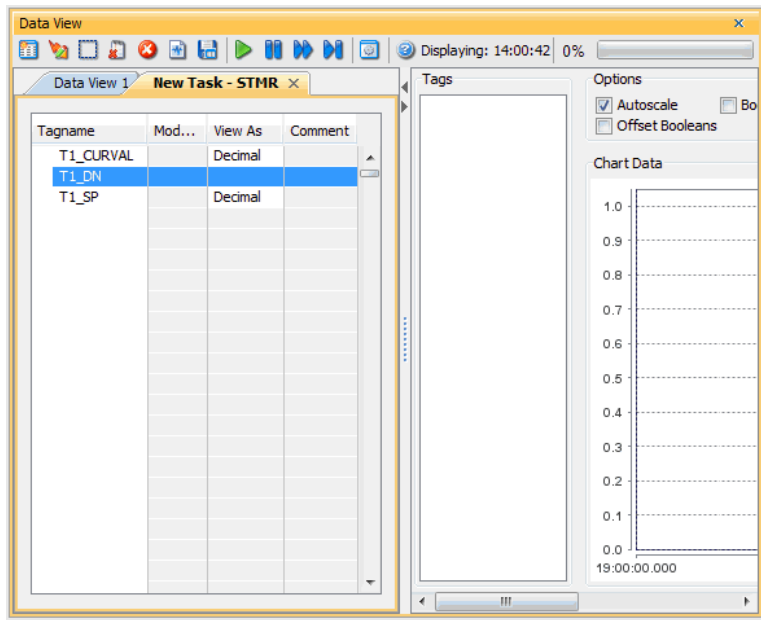

The remaining tagnames in the Ladder Logic can be added to the Data View window by clicking on a blank area in the Tagname column. This will display a drop down menu where the tags can be selected. Scroll down the list and select the tags to be added.

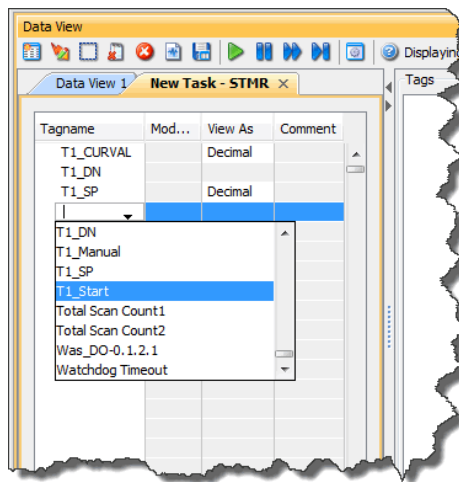

Chapter 1: Getting Started

Once all of the tagnames have been added, they may now be monitored and manipulated. See the Data View help file topic for additional details if needed.



NOTE: Force must be enabled for a Tag in the Tag Database, before Force can be used in Data View.

