



IRONHORSE®

GENERAL PURPOSE AC MOTORS

Manual Number: IH-MT-AC_UMW

Motor Series:

MTR

MTR2

MTRP

MTRJ

MTDP

MTF2

MTSS

MTCP2



**BLANK
PAGE**

~ WARNING ~

Thank you for purchasing automation equipment from Automationdirect.com™, doing business as AutomationDirect. We want your new automation equipment to operate safely. Anyone who installs or uses this equipment should read this publication (and any other relevant publications) before installing or operating the equipment.

To minimize the risk of potential safety problems, you should follow all applicable local and national codes that regulate the installation and operation of your equipment. These codes vary from area to area and usually change with time. It is your responsibility to determine which codes should be followed, and to verify that the equipment, installation, and operation are in compliance with the latest revision of these codes.

At a minimum, you should follow all applicable sections of the National Fire Code, National Electrical Code, and the codes of the National Electrical Manufacturer's Association (NEMA). There may be local regulatory or government offices that can also help determine which codes and standards are necessary for safe installation and operation.

Equipment damage or serious injury to personnel can result from the failure to follow all applicable codes and standards. We do not guarantee the products described in this publication are suitable for your particular application, nor do we assume any responsibility for your product design, installation, or operation.

Our products are not fault-tolerant and are not designed, manufactured or intended for use or resale as on-line control equipment in hazardous environments requiring fail-safe performance, such as in the operation of nuclear facilities, aircraft navigation or communication systems, air traffic control, direct life support machines, or weapons systems, in which the failure of the product could lead directly to death, personal injury, or severe physical or environmental damage ("High Risk Activities"). AutomationDirect specifically disclaims any expressed or implied warranty of fitness for High Risk Activities.

For additional warranty and safety information, see the Terms and Conditions section of our catalog. If you have any questions concerning the installation or operation of this equipment, or if you need additional information, please call us at 770-844-4200.

This publication is based on information that was available at the time it was printed. At AutomationDirect we constantly strive to improve our products and services, so we reserve the right to make changes to the products and/or publications at any time without notice and without any obligation. This publication may also discuss features that may not be available in certain revisions of the product.

TRADEMARKS

This publication may contain references to products produced and/or offered by other companies. The product and company names may be trademarked and are the sole property of their respective owners. AutomationDirect disclaims any proprietary interest in the marks and names of others.

**Copyright 2007–2020 Automationdirect.com™ Incorporated
All Rights Reserved**

No part of this manual shall be copied, reproduced, or transmitted in any way without the prior, written consent of Automationdirect.com™ Incorporated. AutomationDirect retains the exclusive rights to all information included in this document.

~ AVERTISSEMENT ~

Nous vous remercions d'avoir acheté l'équipement d'automatisation de Automationdirect.com™, en faisant des affaires comme AutomationDirect. Nous tenons à ce que votre nouvel équipement d'automatisation fonctionne en toute sécurité. Toute personne qui installe ou utilise cet équipement doit lire la présente publication (et toutes les autres publications pertinentes) avant de l'installer ou de l'utiliser.

Afin de réduire au minimum le risque d'éventuels problèmes de sécurité, vous devez respecter tous les codes locaux et nationaux applicables régissant l'installation et le fonctionnement de votre équipement. Ces codes diffèrent d'une région à l'autre et, habituellement, évoluent au fil du temps. Il vous incombe de déterminer les codes à respecter et de vous assurer que l'équipement, l'installation et le fonctionnement sont conformes aux exigences de la version la plus récente de ces codes.

Vous devez, à tout le moins, respecter toutes les sections applicables du Code national de prévention des incendies, du Code national de l'électricité et des codes de la National Electrical Manufacturer's Association (NEMA). Des organismes de réglementation ou des services gouvernementaux locaux peuvent également vous aider à déterminer les codes ainsi que les normes à respecter pour assurer une installation et un fonctionnement sûrs.

L'omission de respecter la totalité des codes et des normes applicables peut entraîner des dommages à l'équipement ou causer de graves blessures au personnel. Nous ne garantissons pas que les produits décrits dans cette publication conviennent à votre application particulière et nous n'assumons aucune responsabilité à l'égard de la conception, de l'installation ou du fonctionnement de votre produit.

Nos produits ne sont pas insensibles aux défaillances et ne sont ni conçus ni fabriqués pour l'utilisation ou la revente en tant qu'équipement de commande en ligne dans des environnements dangereux nécessitant une sécurité absolue, par exemple, l'exploitation d'installations nucléaires, les systèmes de navigation aérienne ou de communication, le contrôle de la circulation aérienne, les équipements de survie ou les systèmes d'armes, pour lesquels la défaillance du produit peut provoquer la mort, des blessures corporelles ou de graves dommages matériels ou environnementaux («activités à risque élevé»). La société AutomationDirect nie toute garantie expresse ou implicite d'aptitude à l'emploi en ce qui a trait aux activités à risque élevé.

Pour des renseignements additionnels touchant la garantie et la sécurité, veuillez consulter la section Modalités et conditions de notre documentation. Si vous avez des questions au sujet de l'installation ou du fonctionnement de cet équipement, ou encore si vous avez besoin de renseignements supplémentaires, n'hésitez pas à nous téléphoner au 770-844-4200.

Cette publication s'appuie sur l'information qui était disponible au moment de l'impression. À la société AutomationDirect, nous nous efforçons constamment d'améliorer nos produits et services. C'est pourquoi nous nous réservons le droit d'apporter des modifications aux produits ou aux publications en tout temps, sans préavis ni quelque obligation que ce soit. La présente publication peut aussi porter sur des caractéristiques susceptibles de ne pas être offertes dans certaines versions révisées du produit.

MARQUES DE COMMERCE

La présente publication peut contenir des références à des produits fabriqués ou offerts par d'autres entreprises. Les désignations des produits et des entreprises peuvent être des marques de commerce et appartiennent exclusivement à leurs propriétaires respectifs. AutomationDirect nie tout intérêt dans les autres marques et désignations.

**Copyright 2007–2020 Automationdirect.com™ Incorporated
Tous droits réservés**

Nulle partie de ce manuel ne doit être copiée, reproduite ou transmise de quelque façon que ce soit sans le consentement préalable écrit de la société Automationdirect.com™ Incorporated. AutomationDirect conserve les droits exclusifs à l'égard de tous les renseignements contenus dans le présent document.



USER MANUAL REVISION HISTORY

PUBLICATION HISTORY

Please include the Manual Number and the Manual Issue, both shown below, when communicating with Technical Support regarding this publication.

MANUAL NUMBER: **IH-MT-AC_UMW**
ISSUE: **11TH EDITION, REVISION D**
ISSUE DATE: **AUGUST 26, 2024**

Publication History		
Issue	Date	Description of Changes
First Edition	09/2007	Original Issue
1st Ed., Rev. A	11/2007	Chapter 2 wiring diagrams
Second Edition	12/2008	User manual name change (previously "IH-USER-M"). Deleted obsolete motor MTR-002-1AB18. Added MTC-xxx-xxxxCK cast iron TC-frame motors. Revised specs for existing MTC-xxx-xxxx cast iron T-frame motors.
Third Edition	06/2009	Added 1200 and 3600 rpm motors
Fourth Edition	06/2011	Added Premium Efficiency motors and replacement parts for cast-iron motors. Some minor specification changes for existing motors.
Fifth Edition	06/2012	Added MTSS stainless-steel motors & accessories. Added MTR-1P5-1AB36 motor & accessories.
5th Ed., Rev. A	08/2012	Revised MTSS rotor inertia data (chapter 1)
Sixth Edition	10/2014	User manual name change (previously "IH-USER-M-WO"). Added MTF & MTR2 motors. Added MTCP motor 50Hz specs (chapter 1). Added single-phase motor reversing wiring diagrams (chapter 2).
6th Ed., Rev. A	07/17/2015	Ch1, MTF specification table note. Ch2, MTR2 wiring diagram.
7th Edition	01/12/2017	User manual name change (previously "IH-MT-AC-USER-M-WO"). Ch1, Added MTRP (Premium) Motors. Ch2, "Inspection Before Startup," "Motor Mounting Orientation." Ch4, Added MTR2 accessory.
8th Edition	01/18/2018	Ch1, Added MTR2 Motors. Ch2, Added MTR2 mounting dimensions. Ch5, Added performance curves for MTR2 motors.
8th Ed., Rev. A	05/23/2018	Ch3, Bearing #s Ch5, Added additional performance curves for MTR2 motors, added curves for MTRP motors
9th Edition	12/05/2018	Replaced MTCP motors with MTCP2 throughout manual. Added new Chapter 6 for legacy motors and moved MTC, MTCP, MTR, and MTSS motors info to Chapter 6.
9th Ed., Rev. A	03/22/2019	Ch2, Revised shaft diameter dimensions for MTCP2 254T(C)- & 256T(C)-Frame motors. Ch5, Consolidated Shipping Crate Dimensions table. Ch6, Consolidated and rearranged legacy motors spec and performance data tables.

Publication History		
<i>Issue</i>	<i>Date</i>	<i>Description of Changes</i>
10th Ed.	09/02/2020	MTF Motors moved to Legacy Motors, Chapter 6. MTF2 Farm Duty Motors added. MTDP Open Drip-proof motors added.
10th Ed., Rev. A	01/06/2021	MTDP specification changes (affects motors manufactured after September 2020), Chapter 1
11th Ed.	06/29/2022	MTRJ Jet Pump motors added
11th Ed. Rev. A	02/17/2023	Ch2: MTRJ Jet Pump motors Wiring Diagram updated
11th Ed. Rev. B	01/08/2024	Ch2: MTDP motors Wiring Diagram updated
11th Ed. Rev. C	07/22/2024	Ch2: MTCP2 motors Wiring Diagram added
11th Ed. Rev. D	08/26/2024	Ch1: Removed 50Hz ratings from MTR series 1 phase motors

BLANK
PAGE

USER MANUAL TABLE OF CONTENTS



CONTENTS OF THIS USER MANUAL

<u>IRONHORSE GENERAL PURPOSE AC MOTORS USER MANUAL</u>	<u>CF-1</u>
<u>WARNINGS</u>	<u>W-1</u>
~ WARNING ~.....	W-1
Trademarks.....	W-1
~ AVERTISSEMENT ~.....	W-2
Marques de commerce.....	W-2
<u>USER MANUAL REVISION HISTORY</u>	<u>H-1</u>
<u>IRONHORSE GENERAL PURPOSE AC MOTORS USER MANUAL TABLE OF CONTENTS</u>	<u>TOC-1</u>
<u>CHAPTER 1: GETTING STARTED</u>	<u>1-1</u>
Manual Overview.....	1-2
Overview of this Publication.....	1-2
Who Should Read This Manual.....	1-2
Technical Support.....	1-2
Special Symbols.....	1-2
Available Models.....	1-3
MTF2 Conveyor/Farm-Duty T-Frame Single-Phase Motors – Features and Specifications.....	1-3
MTR2 Rolled-Steel 56C/56HC-Frame Single-Phase Motors – Features and Specifications.....	1-4
MTRJ Centrifugal Jet Pump One-Phase Motors – Features and Specifications.....	1-6
MTDP Open Drip-Proof AC Three-Phase Motors – Features and Specifications.....	1-7
MTR2 and MTRP Rolled-Steel 56C/56HC-Frame Three-Phase Motors – Features and Specifications.....	1-10
MTRJ Centrifugal Jet Pump Three-Phase Motors – Features and Specifications.....	1-12
MTCP2 Premium-Efficiency Cast-Iron Three-Phase Motors – Features and Specifications.....	1-13
Receiving and Inspection.....	1-26
Unpacking.....	1-26
IronHorse® Part Number Explanation.....	1-26
Reshipping.....	1-27
Long Term Storage.....	1-27
Warranty.....	1-27
<u>CHAPTER 2: MOUNTING AND INITIAL STARTUP</u>	<u>2-1</u>
Safety Information.....	2-2
Danger!.....	2-2
Wiring Notes: PLEASE READ PRIOR TO INSTALLATION.....	2-2
Applicable Codes.....	2-2
Motor Dimensions.....	2-3
(Dimensions = inches).....	2-3

<i>MTF2 T-Frame Single-phase Farm-Duty Motor Dimensions</i>	2-3
<i>MTR2 56(H)C-Frame Single-phase Rolled-steel Motor Dimensions</i>	2-3
<i>MTR2 56C-Frame Three-phase Rolled-steel Motor Dimensions</i>	2-4
<i>MTRP 56HC-Frame Three-phase Rolled-steel Motor Dimensions</i>	2-5
<i>MTDP Open Drip-Proof Three-phase Rolled-steel Motor Dimensions</i>	2-6
<i>MTCP2 Premium-Efficiency T-Frame Three-Phase Motor Dimensions</i>	2-7
<i>MTCP2 Premium-Efficiency TC-Frame Three-Phase Motor Dimensions</i>	2-11
<i>Terminal and Wiring Diagrams</i>	2-13
<i>IronHorse® Single-Phase Motors</i>	2-13
<i>IronHorse® Three-Phase Motors</i>	2-14
<i>Single-Phase Motors Reversing Diagrams</i>	2-16
<i>Motor Mounting</i>	2-18
<i>General Mounting Information</i>	2-18
<i>Motor Mounting Orientation</i>	2-18
<i>Proper Installation Conditions</i>	2-19
<i>Coupling Alignment</i>	2-19
<i>Motor Nameplate & Starter Information</i>	2-20
<i>Typical IronHorse® Motor Nameplate</i>	2-20
<i>Motor Starter Information</i>	2-20
<i>Locked Rotor Amps</i>	2-20
<i>Inspection Before Startup</i>	2-21
<i>Initial Startup Inspection</i>	2-21
<u>CHAPTER 3: MAINTENANCE</u>	3-1
<i>Routine Maintenance</i>	3-2
<i>Bearing Size Information</i>	3-3
<u>CHAPTER 4: ACCESSORIES</u>	4-1
<i>Replacement Parts</i>	4-2
<i>Junction boxes, c-flanges, Drive Bells, and Current Diverter Rings for IronHorse® MTDP Drip-Proof Three-Phase Motors</i>	4-2
<i>Capacitors and Centrifugal Switches for IronHorse® Single-Phase Motors</i>	4-4
<i>Spare/Replacement Parts for MTF2 Single-Phase Farm-Duty Motors</i>	4-4
<i>Spare/Replacement Parts for MTR2/MTRJ Single-Phase Motors</i>	4-6
<i>Spare/Replacement Parts for MTR2/MTRP/MTRJ Three-Phase Motors</i>	4-7
<i>Spare/Replacement Parts for MTCP2 Premium-Efficiency Three-Phase Motors</i>	4-8
<i>C-Flange Kits</i>	4-10
<i>C-Flange Kits for MTCP2 Premium-Efficiency Three-Phase Motors</i>	4-10
<i>STABLE™ Slide Bases</i>	4-12
<i>Slide Base Selection</i>	4-13
<i>Slide Base Dimensions</i>	4-14
<u>CHAPTER 5: REFERENCE INFORMATION</u>	5-1
<i>Using IronHorse® Motors with AC Drives</i>	5-2
<i>Voltage Spike Considerations for AC Drive Control</i>	5-3
<i>Radial Overhung Load</i>	5-4
<i>F1 and F2 Mounting</i>	5-5
<i>Junction Box Dimensions</i>	5-6
<i>Minimum Sheave Diameters</i>	5-7
<i>Decibel Levels</i>	5-8

<i>Shipping Crate Dimensions</i>	5-10
<i>Performance Curves for MTF2 Motors</i>	5-11
<i>Performance Curves for MTR2 Motors</i>	5-16
<i>Performance Curves for MTDP Motors</i>	5-34
<i>Performance Curves for MTRP Motors</i>	5-50
<i>Speed/Torque Curves for MTCP2 Motors (1800 RPM)</i>	5-57
<i>Speed/Torque Curves for MTCP2 Motors (1200 RPM)</i>	5-64
<i>Speed/Torque Curves for MTCP2 Motors (3600 RPM)</i>	5-68
CHAPTER 6: LEGACY MOTORS	6-1
Chapter Overview.....	6-3
MTCP Series Motors.....	6-3
MTCP Features and Specifications.....	6-3
MTCP Specifications.....	6-4
MTCP Motor Performance Data.....	6-6
MTCP Motor Dimensions.....	6-10
MTCP Junction Box Dimensions.....	6-16
MTCP Decibel Levels.....	6-17
Spare/Replacement Parts for MTCP Premium-Efficiency Three-Phase Motors.....	6-18
MTCP Bearing Size Information.....	6-20
MTR Series Motors.....	6-21
MTR Features and Specifications (Single-Phase Motors).....	6-21
MTR Features and Specifications (Three-Phase Motors).....	6-22
MTR Motor Dimensions.....	6-24
MTR Junction Box Dimensions.....	6-25
MTR Terminal and Wiring Diagrams.....	6-25
MTR Motors Decibel Levels.....	6-25
Spare/Replacement Parts for MTR Single-Phase Motors.....	6-26
MTR Bearing Size Information.....	6-26
MTSS Series Motors.....	6-27
MTSS Features and Specifications.....	6-27
MTSS Motor Dimensions.....	6-29
MTSS Junction Box Dimensions.....	6-30
MTSS Decibel Levels.....	6-30
MTSS Motor Mounting.....	6-31
Spare/Replacement Parts for MTSS Stainless-Steel Three-Phase Motors.....	6-32
MTSS Bearing Size Information.....	6-32
MTC EAct Series Motors.....	6-33
MTC Features and Specifications.....	6-33
MTC Motor Dimensions.....	6-41
MTC Junction Box Dimensions.....	6-46
MTC Motors Decibel Levels.....	6-47
C-Flange Kits for MTC EAct Three-Phase Motors.....	6-47
MTC Motors Bearing Size Information.....	6-49
MTF Farm-Duty T-Frame Single-Phase Motors – Features and Specifications.....	6-50
Motor Dimensions.....	6-51
MTF T-Frame Single-phase Farm-Duty Motor Dimensions.....	6-51
Terminal and Wiring Diagrams.....	6-51
Replacement Parts.....	6-52

<i>Capacitors and Centrifugal Switches for IronHorse® Single-Phase Motors</i>	6-52
<i>Spare/Replacement Parts for MTF Single-Phase Farm-Duty Motors</i>	6-52
<i>Junction Box Dimensions</i>	6-53

GETTING STARTED



CHAPTER

1

TABLE OF CONTENTS

<i>Manual Overview</i>	1-2
<i>Overview of this Publication</i>	1-2
<i>Who Should Read This Manual</i>	1-2
<i>Technical Support</i>	1-2
<i>Special Symbols</i>	1-2
<i>Available Models</i>	1-3
<i>MTF2 Conveyor/Farm-Duty T-Frame Single-Phase Motors – Features and Specifications</i>	1-3
<i>MTR2 Rolled-Steel 56C/56HC-Frame Single-Phase Motors – Features and Specifications</i>	1-4
<i>MTRJ Centrifugal Jet Pump One-Phase Motors – Features and Specifications</i>	1-6
<i>MTDP Open Drip-Proof AC Three-Phase Motors – Features and Specifications</i>	1-7
<i>MTR2 and MTRP Rolled-Steel 56C/56HC-Frame Three-Phase Motors – Features and Specifications</i> .1-10	
<i>MTRJ Centrifugal Jet Pump Three-Phase Motors – Features and Specifications</i>	1-12
<i>MTCP2 Premium-Efficiency Cast-Iron Three-Phase Motors – Features and Specifications</i>	1-13
<i>Receiving and Inspection</i>	1-26
<i>Unpacking</i>	1-26
<i>IronHorse® Part Number Explanation</i>	1-26
<i>Reshipping</i>	1-27
<i>Long Term Storage</i>	1-27
<i>Warranty</i>	1-27

MANUAL OVERVIEW

OVERVIEW OF THIS PUBLICATION

The IronHorse® General Purpose AC Motor User Manual describes the installation, maintenance and use of all IronHorse General Purpose Motors.

WHO SHOULD READ THIS MANUAL

This manual contains important information for those who will install, maintain, use and/or resell any of the IronHorse motors.

TECHNICAL SUPPORT

By Telephone: **770-844-4200** (Mon.-Fri., 9:00 a.m.-6:00 p.m. E.T.)

On the Web: **support.automationdirect.com**

Our technical support group is glad to work with you in answering your questions. If you cannot find the solution to your particular application, or, if for any reason you need additional technical assistance, please call technical support at 770-844-4200. We are available weekdays from 9:00 a.m. to 6:00 p.m. Eastern Time.

We also encourage you to visit our web site where you can find technical and non-technical information about our products and our company. Visit us at **www.automationdirect.com**.

SPECIAL SYMBOLS



NOTE: When you see the “notepad” icon in the left-hand margin, the paragraph to its immediate right will be a special note.



WARNING: WHEN YOU SEE THE “EXCLAMATION MARK” ICON IN THE LEFT-HAND MARGIN, THE PARAGRAPH TO ITS IMMEDIATE RIGHT WILL BE A WARNING. THIS INFORMATION COULD PREVENT INJURY, LOSS OF PROPERTY, OR EVEN DEATH (IN EXTREME CASES).

AVAILABLE MODELS

This manual covers Ironhorse series AC motor models:

MTR, MTR2, MTRP, MTRJ - Black TEFC motors

MTF2 - Green TEFC Farm Duty motors

MTDP - Blue ODP (Open Drip Proof) motors

MTSS - Stainless Steel IP56 TEFC motors

MTCP2 - Gray Cast Iron TEFC motors



NOTE: For the MTSP MTSN Stainless Steel IP69K series, see [the technical specifications pages](#). These are not included in this manual.

MTF2 CONVEYOR/FARM-DUTY T-FRAME SINGLE-PHASE MOTORS – FEATURES AND SPECIFICATIONS



IronHorse® single-phase farm-duty motor available ratings are 2hp to 10hp. All models have a TEFC housing (steel frame with iron end bells) that is fully gasketed for use in dirty environments. Motors are NEMA H, J, K and L design. All models include a class-10 manual-reset locked-rotor thermal protector (motor thermal overload protection must be provided separately).

WE RECOMMEND DISCONNECTING POWER TO THE MOTOR BEFORE RESETTING THE THERMAL PROTECTOR. DO NOT RESET MORE THAN TWICE IN SUCCESSION. THE MOTOR MUST COOL TO 40°C (104°F) BEFORE A THIRD RESET.

CAST-IRON T-FRAME 1-PHASE FARM-DUTY MOTOR SPECIFICATIONS

Motor Specifications – Single-Phase Farm-Duty Motors (60Hz)									
Part Number	HP	Base RPM	Voltage*	Service Factor	NEMA Design	NEMA Frame	Housing	F.L. Amps @208/230VAC	Approx Weight (lb)
MTF2-002-1B18-182	2	1800	208 / 230VAC ±10%	1.15 @ 230VAC 1.0 @ 208VAC	L	182T	TEFC IP55	9.3 / 8.5	67
MTF2-003-1B18	3					184T		13.5 / 12.5	76
MTF2-005-1B18	5					215T		22.2 / 20.2	100
MTF2-7P5-1B18-215	7.5					31.5 / 28.7		134	
MTF2-010-1B18	10					45.2 / 38.8		149	

* Operate on 230VAC +/- 10% (1.15 @ 230VAC; 1.0 S.F. @ 208V), single-phase power only.

CAST-IRON T-FRAME 1-PHASE FARM-DUTY MOTOR PERFORMANCE DATA

Performance Data – Single-Phase Farm-Duty Motors (60Hz)											
Part Number	HP	F.L. RPM	Current @ 230V (Amps)			Torque (lb-ft)			F.L. Efficiency (%)	F.L. Power Factor	Rotor Inertia (lb-ft ²)
			230V No Load	Full Load	Locked Rotor	Full Load	Locked Rotor	Break down			
MTF2-002-1B18-182	2	1764	3.0	8.5	78.6	6.01	21.8	22.1	84.0	0.92	0.27
MTF2-003-1B18	3	1769	4.2	12.5	89.2	8.76	24.9	24.3	84.4	0.91	0.34
MTF2-005-1B18	5	1769	6.3	20.2	170.7	14.7	57.2	57.3	86.4	0.92	0.49
MTF2-7P5-1B18-215	7.5	1767	8.2	28.7	238.5	21.91	82.8	82.1	86.6	0.96	0.74
MTF2-010-1B18	10	1765	11.79	38.8	365.8	29.93	119.6	122.6	87.5	0.96	0.85

MTR2 ROLLED-STEEL 56C/56HC-FRAME SINGLE-PHASE MOTORS – FEATURES AND SPECIFICATIONS



IronHorse® single-phase 56C/56HC-frame* motors available ratings are 1/3 hp to 2 hp. All models have a TEFC rolled steel frame, cast aluminum end bell and removable mounting bases.

SPECIFICATIONS – ROLLED-STEEL 56C-FRAME 1-PHASE MOTOR

Motor Specifications – Single-Phase 56C/56HC-Frame Motors									
Part Number	HP	Base RPM	Voltage	Service Factor	NEMA Design	NEMA Frame	Housing	F.L. Amps @115V/230V 60Hz	Approx Weight (lb)
	@ 60Hz								
1800 RPM									
MTR2-P33-1AB18	1/3	1800	115/230	1.15	N	56C flange mount	IP43 TEFCrolled steel frame Cast AL end bell F1 conduit box location	5.2 / 2.6	22
MTR2-P50-1AB18	1/2							7.2 / 3.6	25
MTR2-P75-1AB18	3/4							10.0 / 5.0	29
MTR2-001-1AB18	1				13.0 / 6.5	36			
MTR2-1P5-1AB18	1-1/2				14.5 / 7.3	37			
MTR2-002-1AB18	2				19.6 / 9.8	44			
3600 RPM									
MTR2-P33-1AB36	1/3	3600	115/230	1.15	N	56C	IP43 TEFCrolled steel frame Cast AL end bell F1 conduit box location	5.4 / 2.7	21
MTR2-P50-1AB36	1/2							6.5 / 3.3	23
MTR2-P75-1AB36	3/4							9.2 / 4.6	27
MTR2-001-1AB36	1				11.5 / 5.8	30			
MTR2-1P5-1AB36	1-1/2				13.0 / 6.5	31			
MTR2-002-1AB36	2				17.0 / 8.5	37			

Note: Please review the AutomationDirect Terms & Conditions for warranty and service on this product.



NOTE: *56HC are suitable for 56C C-face mounting or 56, 143T, or 145T frame foot mounting dimensions.

MTR2 ROLLED-STEEL 56C/56HC-FRAME SINGLE-PHASE MOTORS FEATURES AND SPECIFICATIONS (CONTINUED)

PERFORMANCE DATA – ROLLED-STEEL 56C-FRAME 1-PHASE MOTOR

Performance Data – Single-Phase 56C/56HC-Frame Motors											
Part Number	HP	F.L. RPM	Current @ 115V/230V (Amps)			Torque (lb·ft)			F.L. Efficiency (%)	F.L. Power Factor	Rotor Inertia (lb·ft ²)
	@60Hz	230V No Load	Full Load	Locked Rotor	Full Load	Locked Rotor	Break down				
1800 RPM											
MTR2-P33-1AB18	1/3	1725	2.05	5.2 / 2.6	33 / 16	1.01	3.54	2.57	63.0	0.58	0.048
MTR2-P50-1AB18	1/2		2.74	7.2 / 3.6	44 / 21	1.49	5.09	3.54	64.5	0.68	0.059
MTR2-P75-1AB18	3/4		3.14	10.0 / 5.0	62 / 30	2.26	7.06	5.16	67.0	0.71	0.074
MTR2-001-1AB18	1		4.39	13.0 / 6.5	80 / 40	3.03	9.30	8.23	70.0	0.69	0.095
MTR2-1P5-1AB18	1-1/2		5.23	14.5 / 7.3	110 / 55	4.46	8.70	10.45	77.0	0.84	0.095
MTR2-002-1AB18	2		8.07	19.6 / 9.8	152 / 76	6.06	12.17	13.81	79.0	0.82	0.121
3600 RPM											
MTR2-P33-1AB36	1/3	3450	2.14	5.4 / 2.7	37 / 19	0.50	2.18	1.96	59.5	0.72	0.031
MTR2-P50-1AB36	1/2		2.23	6.5 / 3.3	47 / 23	0.74	2.59	2.42	63.0	0.74	0.034
MTR2-P75-1AB36	3/4		2.82	9.2 / 4.6	66 / 33	1.12	4.62	3.44	66.5	0.78	0.041
MTR2-001-1AB36	1		3.04	11.5 / 5.8	82 / 41	1.50	4.48	3.83	69.5	0.80	0.047
MTR2-1P5-1AB36	1-1/2		3.90	13.0 / 6.5	109 / 55	2.21	3.22	5.08	77.0	0.94	0.047
MTR2-002-1AB36	2		4.51	17.0 / 8.5	131 / 65	3.02	4.45	6.82	79.5	0.94	0.060

MTRJ CENTRIFUGAL JET PUMP ONE-PHASE MOTORS – FEATURES AND SPECIFICATIONS



IronHorse® MTRJ Jet Pump motors range in size from 1/3 - 2 HP at 3600 RPM. All models come in a 56J frame size in a Totally Enclosed Fan Cooled (TEFC) Enclosure with IP43 protection.

SPECIFICATIONS - CENTRIFUGAL JET PUMP AC ONE-PHASE MOTOR

Motor Specifications – 1-phase										
Part Number	HP*	Base RPM *	Volts*	Encl.	NEMA Frame	Service Factor*	F.L. Amps*	Sound Power (dB)	Weight (lb)	Drawing Links
Removable Rigid Base With C-face										
MTRJ-P33-1AB36J	1/3	3600	115/230 VAC	TEFC	NEMA 56J	1.15	5.0/2.5	80 dB(A)	19.4	PDF
MTRJ-P50-1AB36J	1/2						6.6/ 3.3		21	PDF
MTRJ-P75-1AB36J	3/4						9.0 / 4.5		25.5	PDF
MTRJ-001-1AB36J	1						11.4/5.7		28.3	PDF
MTRJ-1P5-1AB36J	1 1/2						13.0 / 6.5	85 dB(A)	30.7	PDF
MTRJ-002-1AB36J	2						17.2 / 8.6		36.6	PDF

Performance Data - 1-phase													
Part Number	HP*	F.L. RPM*	NEMA Design	F.L. Effic. %	Current			Torque			F.L. Power Factor	Moment of Inertia (lb·ft ²)	
					Full Load Amps	Locked Rotor Amps	No Load Current	Full Load (lb·ft)	Locked Rotor	Breakdown			Pull Up
Removable Rigid Base With C-face - 3600 RPM													
MTRJ-P33-1AB36J	1/3	3450	N	55.0	5.0/2.5	19.51	2.64	0.51	145	250	95	85.00	0.02450
MTRJ-P50-1AB36J	1/2			59.5	6.6/ 3.3	25.22	3.19	0.76	130	265	90		0.02770
MTRJ-P75-1AB36J	3/4			66.0	9.0 / 4.5	47.22	4.95	1.12		220	100	81.00	0.03820
MTRJ-001-1AB36J	1			70.0	11.4/5.7	61.78	5.97	1.53	125	225	75	82.00	0.04580
MTRJ-1P5-1AB36J	1 1/2			78.5	13.0 / 6.5	82.74	8.34	2.25	115	220	110	94.00	0.04720
MTRJ-002-1AB36J	2			80.0	17.2 / 8.6	116.2	8.64	3.06	140	205	95	95.00	0.06020

MTDP OPEN DRIP-PROOF AC THREE-PHASE MOTORS – FEATURES AND SPECIFICATIONS



IronHorse® MTDP, open drip-proof motors range in size from 1hp to 50hp at 1800 rpm and 3hp, 5hp, and 7.5 hp at 3600 rpm. Frame sizes are available from 143T to 326T. All models have a rolled steel frame; frames sizes up to 256T have cast aluminum end bells, while frame sizes of 284T or larger have cast iron end bells. All frame sizes have a fixed base. 15 - 50 horsepower models made after June 2023 have 12 motor leads for high-voltage, Wye/Delta starting.

SPECIFICATIONS – OPEN DRIP-PROOF AC THREE-PHASE MOTOR

Motor Specifications – MTDP Open Drip-Proof Three-Phase Motors (60Hz except as indicated)									
Part Number	HP	Base RPM	Voltage	Service Factor	NEMA Design	NEMA Frame	Housing	F.L. Amps @ 208/230V/460V 60Hz	Approx Weight (lb)
1800 RPM									
MTDP-001-3BD18	1	1800	208–230/460 VAC	1.15 (sine), 1.0 (drive)	BB	NEMA 143T	ODP IP23ODP	2.9 / 2.6 / 1.3	33.1
MTDP-1P5-3BD18	1 1/2	1800	208–230/460 VAC			NEMA 145T		3.1/2.8/1.4*	
MTDP-002-3BD18	2	1800	208–230/460 VAC			NEMA 145T		4.6 / 4.2 / 2.1	34.2
MTDP-003-3BD18	3	1800	208–230/460 VAC			NEMA 182T		5.9 / 5.4 / 2.7	38.6
MTDP-005-3BD18	5	1800	208–230/460 VAC			NEMA 184T		7.9 / 7.6 / 3.8	68.3
MTDP-7P5-3BD18	7 1/2	1800	208–230/460 VAC			NEMA 213T		8.7/7.8/3.9*	
MTDP-010-3BD18	10	1800	208–230/460 VAC			NEMA 215T		13.6 / 12.4 / 6.2	91.5
MTDP-015-3BD18	15	1800	208–230/460 VAC			NEMA 254T		13.7/12.4/6.2*	
MTDP-020-3BD18	20	1800	208–230/460 VAC			NEMA 256T		20.7 / 18.8 / 9.4	140.2
MTDP-025-3BD18	25	1800	208–230/460 VAC			NEMA 284T		21.7/19.6/9.8*	
MTDP-030-3BD18	30	1800	208–230/460 VAC			NEMA 286T		28.3 / 25.6/12.8	156.0
MTDP-040-3BD18	40	1800	208–230/460 VAC			NEMA 324T		37.6 / 34.2 / 17.1	214.9
MTDP-050-3BD18	50	1800	208–230/460 VAC			NEMA 326T		38.5/34.8/17.4*	
								51.5/46.6/23.3*	
								66.3 / 60.0 / 30.0	300.0
								79.4 / 71.8 / 35.9	330.0
								77.6/70.2/35.1*	
								105.6 / 95.8 / 47.9	440
								130.3 / 117.4 / 58.7	470
								131.2/118.6/59.3*	
3600 RPM									
MTDP-003-3BD36	3	3600	208–230/460 VAC	1.15 (sine), 1.0 (drive)	B	NEMA 145T	ODP IP23	7.9 / 7.2 / 3.6	39.7
MTDP-005-3BD36	5	3600	208–230/460 VAC			NEMA 182T		8.2/7.4/3.7*	
MTDP-7P5-3BD36	7.5	3600	208–230/460 VAC			NEMA 184T		12.3 / 11.8 / 5.9	64.9
								18.9 / 17.2 / 8.6	78.1
								19.2/17.4/8.7*	

*These specifications apply to motors manufactured after September 2020
 Note: Please review the AutomationDirect Terms & Conditions for warranty and service on this product.

MTDP ROLLED-STEEL THREE-PHASE DRIP-PROOF MOTORS FEATURES AND SPECIFICATIONS

PERFORMANCE DATA (FOR MOTORS MANUFACTURED AFTER SEPTEMBER 2020)

Performance Data – MTDP Rolled Steel Three-Phase Drip-Proof Motors (230V / 60Hz data except as indicated)											
Part Number	HP	F.L. RPM	Current @ 230/460V (Amps)			Torque (lb-ft)			F.L. Efficiency (%)	F.L. Power Factor	Rotor Inertia (lb-ft ²)
	@ 60Hz (50Hz)	230/ 460V No Load	Full Load	Locked Rotor	Full Load	Locked Rotor	Break down				
1800 RPM											
MTDP-001-3BD18	1	1742	1.40/0.70	2.8/1.4	21.18/10.59	3.03	9.51	10.03	85.5	0.81	0.09
MTDP-1P5-3BD18	1.5	1747	2.44 / 1.22	4.2 / 2.1	34.52 / 17.26	4.44	15.63	16.56	88.5	0.76	0.09
MTDP-002-3BD18	2	1744	2.96 / 1.48	5.4 / 2.7	47.24 / 23.62	6.06	21.15	23.45	86.5	0.79	0.10
MTDP-003-3BD18	3	1753	3.74/1.87	7.8/3.9	63.64/31.82	8.80	30.36	31.68	89.5	0.8	0.36
MTDP-005-3BD18	5	1745	4.46 / 2.23	12.4 / 6.2	93.34/46.67	14.90	40.83	46.04	89.5	0.84	0.48
MTDP-7P5-3BD18	7.5	1758	10.56/5.28	19.6/9.8	118.62/59.31	22.02	78.39	81.03	91	0.78	0.95
MTDP-010-3BD18	10	1753	10.24 / 5.12	24.4 / 12.2	160.8 / 80.4	30.14	97.35	100.67	91.7	0.81	1.16
MTDP-015-3BD18	15	1774	11.4/5.7	34.8/17.4	235.6/117.8	43.6	113.36	120.30	93	0.85	2.03
MTDP-020-3BD18	20	1769	13.96/6.98	46.6/23.3	303.4/151.7	59.67	154.54	178.40	93	0.86	2.44
MTDP-025-3BD18	25	1775	24.6 / 12.3	30.0 / 15.0	380 / 190	72.30	175.69	184.37	93.6	0.83	3.25
MTDP-030-3BD18	30	1775	24.8/12.4	70.2/35.1	433/216.5	87.47	252.79	291.28	94.1	0.84	3.69
MTDP-040-3BD18	40	1778	36.8 / 18.4	95.8 / 47.9	630 / 315	118.10	419.26	457.05	94.1	0.84	7.35
MTDP-050-3BD18	50	1781	46.2/23.1	118.6/59.3	771/385.5	146.7	476.78	517.85	94.5	0.83	8.99
MTDP-003-3BD36	3	3441	3.02/1.51	7.4/3.7	63.26/31.63	4.5	18.09	22.28	85.5	0.86	0.07
MTDP-005-3BD36	5	3509	3.64 / 1.82	11.8 / 5.9	94.02 / 47.01	7.43	25.26	26.15	86.5	0.89	0.15
MTDP-7P5-3BD36	7.5	3499	4.86/2.43	17.36/8.68	132.26/66.13	11.02	33.17	41.99	88.5	0.89	0.20

Performance Data – MTDP Rolled Steel Three-Phase Drip-Proof Motors (190/380V / 50Hz data)											
Part Number	HP	F.L. RPM	Current @ 115V/230V (Amps)			Torque (lb-ft)			F.L. Efficiency (%)	F.L. Power Factor	Rotor Inertia (lb-ft ²)
	@ 50Hz	190/380V No Load	Full Load	Locked Rotor	Full Load	Locked Rotor	Break down				
1500 RPM											
MTDP-001-3BD18	1	1449	1.32/0.66	3.2/1.6	20.4/10.2	3.65	8.21	10.13	84.3	0.82	0.09
MTDP-1P5-3BD18	1.5	1450	2.44/1.22	4.8/2.4	32.6/16.3	5.35	15.69	16.63	85.7	0.78	0.09
MTDP-002-3BD18	2	1448	2.96/1.48	6.4/3.2	44.6/22.3	7.31	21.26	23.57	85.7	0.81	0.1
MTDP-003-3BD18	3	1437	3.7/1.85	9.4/4.7	59.8/29.9	10.8	28.87	30.11	88.7	0.84	0.36
MTDP-005-3BD18	5	1445	4.4/2.2	14.9/7.5	87.0/43.5	18	51.77	58.37	88.7	0.87	0.45
MTDP-7P5-3BD18	7.5	1445	8.2/4.1	23.6/11.8	112/56	26.8	72.9	117.14	90.2	0.84	0.95
MTDP-010-3BD18	10	1455	10.24/5.12	29.4/14.7	152.2/76.1	36.4	97.99	101.3	91.2	0.87	1.16
MTDP-015-3BD18	15	1455	10.0/5.0	41.8/20.9	221.8/110.9	53.3	92	113.96	92.4	0.87	2.03
MTDP-020-3BD18	20	1455	13.8/6.9	56.0/28.0	285.2/142.6	72.7	142.72	235.91	92.4	0.87	2.44
MTDP-025-3BD18	25	1455	24.6/12.3	72.0/36.0	359.6/179.8	88.3	178.81	187.64	93.2	0.84	3.25
MTDP-030-3BD18	30	1455	23.8/11.9	84.2/42.1	406.2/203.1	106.6	221.94	232.6	93.7	0.85	3.69
MTDP-040-3BD18	40	1460	36.8/18.4	115.0/57.5	596/298	142.5	421.66	459.56	93.8	0.86	7.35
MTDP-050-3BD18	50	1460	44.6/22.3	142.7/71.2	710.6/355.3	178.6	407.92	442.75	94.1	0.85	8.99
MTDP-003-3BD36	3	2850	2.82/1.41	8.8/4.4	47.0/23.5	5.44	17.71	21.83	84.1	0.89	0.07
MTDP-005-3BD36	5	2919	3.64/1.82	13.6/6.8	91.8/45.9	8.99	25.47	26.37	85.6	0.89	0.15
MTDP-7P5-3BD36	7.5	2870	4.6/2.3	21.0/10.5	128.2/64.1	13.37	32.52	41.11	87.7	0.9	0.2

PERFORMANCE DATA (FOR MOTORS MANUFACTURED PRIOR TO SEPTEMBER 2020)

Performance Data – MTDP Rolled Steel Three-Phase Drip-Proof Motors (230V / 60Hz data except as indicated)											
Part Number	HP	F.L. RPM	Current @ 230/460V (Amps)			Torque (lb-ft)			F.L. Efficiency (%)	F.L. Power Factor	Rotor Inertia (lb-ft ²)
	@ 60Hz (50Hz)	230/ 460V No Load	Full Load	Locked Rotor	Full Load	Locked Rotor	Break down				
1800 RPM											
MTDP-001-3BD18	1	1745	1.32 / 0.66	2.6 / 1.3	21.46 / 10.73	3.03	8.18	10.09	85.5	0.81	0.09
MTDP-1P5-3BD18	1.5	1747	2.44 / 1.22	4.2 / 2.1	34.52 / 17.26	4.44	15.63	16.56	88.5	0.76	0.09
MTDP-002-3BD18	2	1744	2.96 / 1.48	5.4 / 2.7	47.24 / 23.62	6.06	21.15	23.45	86.5	0.79	0.10
MTDP-003-3BD18	3	1759	3.38 / 1.69	7.6 / 3.8	69.90 / 34.95	8.80	32.12	37.58	89.5	0.82	0.36
MTDP-005-3BD18	5	1749	4.46 / 2.23	12.4 / 6.2	105.76 / 52.88	14.90	50.21	57.07	89.5	0.83	0.48
MTDP-7P5-3BD18	7.5	1763	9.52 / 4.76	18.8 / 9.4	141.26 / 70.63	21.98	101.11	87.04	91.0	0.81	0.95
MTDP-010-3BD18	10	1753	10.24 / 5.12	24.4 / 12.2	160.8 / 80.4	30.14	97.35	100.67	91.7	0.81	1.16
MTDP-015-3BD18	15	1776	10.2 / 5.1	34.2 / 17.1	261.8 / 130.9	43.63	101.22	128.27	93.0	0.87	2.03
MTDP-020-3BD18	20	1765	11.06 / 5.53	45.0 / 22.5	325.2 / 162.6	59.84	175.93	166.36	93.0	0.90	2.44
MTDP-025-3BD18	25	1775	24.6 / 12.3	30.0 / 15.0	380 / 190	72.30	175.69	184.37	93.6	0.83	3.25
MTDP-030-3BD18	30	1780	31.4 / 15.7	71.8 / 35.9	499.6 / 249.8	86.67	240.94	276.48	94.1	0.82	3.69
MTDP-040-3BD18	40	1778	36.8 / 18.4	95.8 / 47.9	630 / 315	118.10	419.26	457.05	94.1	0.84	7.35
MTDP-050-3BD18	50	1776	46.0 / 23.0	117.6 / 58.8	818 / 409	145.20	512.56	441.41	94.5	0.84	8.99
MTDP-003-3BD36	3	3439	2.82 / 1.41	7.2 / 3.6	68.62 / 34.31	4.51	17.27	18.67	85.5	0.87	0.07
MTDP-005-3BD36	5	3509	3.64 / 1.82	11.8 / 5.9	94.02 / 47.01	7.43	25.26	26.15	86.5	0.89	0.15
MTDP-7P5-3BD36	7.5	3502	4.6 / 2.3	17.2 / 8.6	135.06 / 67.53	11.06	33.73	38.38	88.5	0.90	0.20

Performance Data – MTDP Rolled Steel Three-Phase Drip-Proof Motors (190/380V / 50Hz data)											
Part Number	HP	F.L. RPM	Current @ 115V/230V (Amps)			Torque (lb-ft)			F.L. Efficiency (%)	F.L. Power Factor	Rotor Inertia (lb-ft ²)
	@ 50Hz	190/380V No Load	Full Load	Locked Rotor	Full Load	Locked Rotor	Break down				
1500 RPM											
MTDP-001-3BD18	1	1449	1.32 / 0.66	3.2 / 1.6	20.4 / 10.2	3.65	8.21	10.11	84.30	0.82	0.09
MTDP-1P5-3BD18	1.5	1450	2.44 / 1.22	4.8 / 2.4	32.6 / 16.3	5.35	15.68	16.64	85.70	0.78	0.09
MTDP-002-3BD18	2	1448	2.96 / 1.48	6.4 / 3.2	44.6 / 22.3	7.31	21.27	23.54	85.70	0.81	0.10
MTDP-003-3BD18	3	1460	3.38 / 1.69	8.6 / 4.3	66.2 / 33.1	10.6	32.25	37.74	88.70	0.84	0.36
MTDP-005-3BD18	5	1452	4.46 / 2.23	14.4 / 7.2	100.0 / 50.0	18.0	50.58	57.60	88.70	0.85	0.48
MTDP-7P5-3BD18	7.5	1464	8.52 / 4.76	21.6 / 10.8	133.8 / 66.9	26.5	101.50	87.45	90.50	0.83	0.95
MTDP-010-3BD18	10	1455	10.24 / 5.12	29.4 / 14.7	152.2 / 76.1	36.4	97.92	101.19	91.20	0.87	1.16
MTDP-015-3BD18	15	1475	10.2 / 5.1	39.4 / 19.7	247.5 / 123.9	52.6	101.52	128.87	92.60	0.88	2.03
MTDP-020-3BD18	20	1465	11.6 / 5.53	51.8 / 25.9	307.6 / 153.8	72.2	176.89	167.50	92.50	0.91	2.44
MTDP-025-3BD18	25	1455	24.6 / 12.3	72.0 / 36.0	359.6 / 179.8	88.3	178.37	187.20	93.20	0.84	3.25
MTDP-030-3BD18	30	1457	31.4 / 15.7	86.2 / 43.1	472.6 / 236.3	104.5	242.44	277.97	93.80	0.85	3.69
MTDP-040-3BD18	40	1460	36.8 / 18.4	115.0 / 57.5	596 / 298	142.5	421.80	458.85	93.80	0.86	7.35
MTDP-050-3BD18	50	1460	46.0 / 23.0	142.4 / 71.2	773.8 / 386.9	175.2	515.09	443.26	94.30	0.85	8.99
MTDP-003-3BD36	3	2860	2.82/1.41	8.6/4.3	67.0/33.5	5.45	17.44	18.80	84.30	0.88	0.07
MTDP-005-3BD36	5	2919	3.64/1.82	13.6/6.8	91.8/45.9	8.99	25.44	26.34	85.60	0.89	0.15
MTDP-7P5-3BD36	7.5	2913	4.6/2.3	20.0/10.0	131.8/65.9	13.37	33.96	38.64	87.60	0.91	0.20

MTR2 AND MTRP ROLLED-STEEL 56C/56HC-FRAME THREE-PHASE MOTORS – FEATURES AND SPECIFICATIONS



IronHorse® rolled steel 56C/56HC-frame* three-phase motors available ratings are from 1/3 hp to 3 hp. All models have a TEFC frame, cast aluminum end bell and removable mounting bases.

SPECIFICATIONS – ROLLED-STEEL 56C/56HC-FRAME 3-PHASE MOTOR – 1800 & 3600 RPM

Motor Specifications – MTR/MTR2 & MTRP 3-Phase 56C/56HC-Frame Motors – 1800 & 3600 rpm									
Part Number	HP	Base RPM	Voltage	Service Factor	NEMA Design	NEMA Frame	Housing	F.L. Amps @ 230V/460V	Approx Weight (lb)
1800 RPM									
MTR2-P33-3BD18	1/3	1800	230/460	1.15	B	56C flange mount (MTRP = 56HC)	TEFC rolled steel frame	1.4 / 0.7	18
MTR2-P50-3BD18	1/2						1.9 / 0.95	19	
MTR2-P75-3BD18	3/4						2.6 / 1.3	22	
MTRP-001-3BD18	1		208-230/460				Cast aluminum end bell	3.2 / 1.6	35
MTRP-1P5-3BD18	1-1/2						4.5 / 2.3	43	
MTRP-002-3BD18	2						F1 conduit box location	6.0 / 3.0	49
3600 RPM									
MTR2-P33-3BD36	1/3	3600	230/460	1.15	B	56C flange mount (MTRP = 56HC)	TEFC rolled steel frame	1.3 / 0.65	18
MTR2-P50-3BD36	1/2						1.7 / 0.85	19	
MTR2-P75-3BD36	3/4						2.4 / 1.2	21	
MTRP-001-3BD36	1		208-230/460				Cast aluminum end bell	3.0 / 1.50	23
MTRP-1P5-3BD36	1-1/2						4.0 / 2.0	31	
MTRP-002-3BD36	2						F1 conduit box location	5.2 / 2.6	33
MTRP-003-3BD36	3	7.4 / 3.7	39						

Note: Please review the AutomationDirect Terms & Conditions for warranty and service on this product.



NOTE: *56HC are suitable for 56C C-face mounting or 56, 143T, or 145T frame foot mounting dimensions.

MTR2 AND MTRP ROLLED-STEEL 56C/56HC-FRAME THREE-PHASE MOTORS FEATURES AND SPECIFICATIONS (CONTINUED)

PERFORMANCE DATA – ROLLED-STEEL 56C/56HC-FRAME 3-PHASE MOTOR – 1800 RPM

Performance Data – MTR/MTR2 Three-Phase 56C/56HC-Frame Motors – 1800 rpm (460V data except as indicated)									
Part Number	HP	F.L. RPM	Minimum Speed (rpm)		Maximum Speed (rpm)		Current @ 230V/460V (Amps)		
			CT	VT	CHP*	Safe	No Load	Full Load	Locked Rotor
MTR2-P33-3BD18	1/3	1725	431	172	2700	5400	1.10 / 0.55	1.4 / 0.7	7 / 3.5
MTR2-P50-3BD18	1/2						1.36 / 0.68	1.9 / 0.95	10 / 5
MTR2-P75-3BD18	3/4						1.60 / 0.80	2.6 / 1.3	12.2 / 6.6
MTRP-001-3BD18	1	1760	440	176	2700	2700	2.2 / 1.1	3.2 / 1.6	31 / 16
MTRP-1P5-3BD18	1-1/2	1760	440	176	2700	2700	2.8 / 1.4	4.5 / 2.3	47 / 24
MTRP-002-3BD18	2	1760	440	176	2700	2700	3.6 / 1.8	6.0 / 3.0	61 / 31
Part Number	HP		Torque (lb-ft)			F.L. Efficiency (%)	F.L. Power Factor	Rotor Inertia (lb-ft ²)	
			Full Load	Locked Rotor	Break -down				
MTR2-P33-3BD18	1/3	N/A	1.03	2.93	3.77	N/A	67.0	0.65	0.0329
MTR2-P50-3BD18	1/2		1.53	3.81	4.96		70.0	0.69	0.038
MTR2-P75-3BD18	3/4		2.31	5.41	7.17		73.0	0.73	0.048
MTRP-001-3BD18	1		3	12.35	14.51		85.0	0.69	0.107
MTRP-1P5-3BD18	1-1/2		4.4	21.68	21.76		86.5	0.72	0.135
MTRP-002-3BD18	2		6.03	27.3	27.46		86.5	0.74	0.158

* Maximum Constant HP rpm is for direct-coupled loads.

PERFORMANCE DATA – ROLLED-STEEL 56C/56HC-FRAME 3-PHASE MOTOR – 3600 RPM

Performance Data – Three-Phase 56C/56HC-Frame Motors – 3600 rpm (460V data except as indicated)									
Part Number	HP	F.L. RPM	Minimum Speed (rpm)		Maximum Speed (rpm)		Current @ 230V/460V (Amps)		
			CT	VT	CHP*	Safe	No Load	Full Load	Locked Rotor
MTR2-P33-3BD36	1/3	3450	862	345	5400	5400	0.8 / 0.4	1.3 / 0.65	7.6 / 3.8
MTR2-P50-3BD36	1/2						1.0 / 0.5	1.7 / 0.85	10.8 / 5.4
MTR2-P75-3BD36	3/4						1.3 / 0.7	2.4 / 1.2	16 / 8
MTRP-001-3BD36	1	3500	875	350	5400	5400	1.52 / 0.76	3.00 / 1.50	22 / 11
MTRP-1P5-3BD36	1-1/2	3500	875	350	5400	5400	1.8 / 0.9	3.96 / 1.98	38 / 19
MTRP-002-3BD36	2	3500	875	350	5400	5400	2.28 / 1.14	5.22 / 2.61	53 / 27
MTRP-003-3BD36	3	3500	875	350	5400	5400	3.54 / 1.77	7.38 / 3.69	89 / 45
Part Number	HP		Torque (lb-ft)			F.L. Efficiency (%)	F.L. Power Factor	Rotor Inertia (lb-ft ²)	
			Full Load	Locked Rotor	Break -down				
MTR2-P33-3BD36	1/3	N/A	0.50	1.14	1.99	N/A	60.0	0.75	0.0245
MTR2-P50-3BD36	1/2		0.74	1.81	2.96		67.5	0.74	0.0277
MTR2-P75-3BD36	3/4		1.14	2.95	4.25		71.5	0.78	0.031
MTRP-001-3BD36	1		1.51	3.98	4.93		77	0.83	0.034
MTRP-1P5-3BD36	1-1/2		2.21	7.94	9.03		84.0	0.85	0.048
MTRP-002-3BD36	2		3.02	12.23	12.8		85.5	0.86	0.056
MTRP-003-3BD36	3	4.49	19.44	20.39	86.5	0.85	0.069		

* Maximum Constant HP rpm is for direct-coupled loads.

MTRJ CENTRIFUGAL JET PUMP THREE-PHASE MOTORS – FEATURES AND SPECIFICATIONS



IronHorse® MTRJ Jet Pump motors range in size from 1/3 - 3 HP at 3600 RPM. All models come in a 56J frame size in a Totally Enclosed Fan Cooled (TEFC) Enclosure with IP43 protection.

SPECIFICATIONS - CENTRIFUGAL JET PUMP AC ONE-PHASE MOTOR

Motor Specifications – 3-phase										
Part Number	HP	Base RPM	Volts	Encl.	NEMA Frame	Service Factor	F.L. Amps	Sound Power (dB)	Weight (lb)	Drawing Links
Removable Rigid Base With C-face - 3600 RPM										
MTRJ-P33-3BD36J	1/3	3600	230/460 VAC (190/380)	TEFC	NEMA 56J	1.15	1.3 / 0.65	80 dB(A)	18	PDF
MTRJ-P50-3BD36J	1/2						1.7 / 0.85		19	PDF
MTRJ-P75-3BD36J	3/4						2.4 / 1.2		21.6	PDF
MTRJP-001-3BD36J	1		208–230/460 VAC (190/380)				3.00/1.50	22.9	PDF	
MTRJP-1P5-3BD36J	1 1/2						3.96/1.98	30.5	PDF	
MTRJP-002-3BD36J	2						5.22/2.61	33.4	PDF	
MTRJP-003-3BD36J	3						7.38/3.69	38.8	PDF	

Performance Data - 3-phase													
Part Number	HP*	F.L. RPM*	NEMA Design	F.L. Effic. %	Current			Torque				F.L. Power Factor	Moment of Inertia (lb-ft ²)
					Full Load Amps	Locked Rotor Amps	No Load Current	Full Load (lb-ft)	Locked Rotor	Breakdown	Pull Up		
Removable Rigid Base With C-face - 3600 RPM													
MTRJ-P33-3BD36J	1/3 (1/4)	3450 (2850)	B	62.0	1.3 / 0.65	3.63	0.44	0.51	180	355	215	79.00	0.02450
MTRJ-P50-3BD36J	1/2 (1/3)			66.0	1.7 / 0.85	3.85	0.43	0.76	150	255	155	86.00	
MTRJ-P75-3BD36J	3/4 (1/2)			74.0	2.4 / 1.2	8.27	0.69	1.12	230	380	275	81.00	
MTRJP-001-3BD36J	1 (3/4)	3500 (2915)		77.0	3.00/1.50	11.37	0.78	1.51	255	325	220	83.00	0.03420
MTRJP-1P5-3BD36J	1 1/2 (1)			84.0	3.96/1.98	25.1	1.08	2.21	495	600	485	82.00	0.04730
MTRJP-002-3BD36J	2 (1)			85.5	5.22/2.61	27.38	1.12	3.02	385	415	315	85.00	0.05610
MTRJP-003-3BD36J	3 (2)			86.5	7.38/3.69	44.55	1.77	4.50	430	450	300		0.06910

*@ 60Hz (@ 50Hz)

MTCP2 PREMIUM-EFFICIENCY CAST-IRON THREE-PHASE MOTORS – FEATURES AND SPECIFICATIONS

Premium Efficiency
Cast-Iron T-Frame

Premium Efficiency
Cast-Iron TC-Frame



IronHorse cast-iron industrial-duty Premium Efficiency motors are available in T-frame housings at speeds of 1200, 1800, and 3600 rpm, and in TC-frame housings at speeds of 1800 rpm. Optional C-face kits are available for IronHorse T-frame Premium Efficiency motors. (Premium Efficiency C-face kits are NOT compatible with EPAct motors.) All models have a TEFC frame and full length mounting feet.



NOTE: For MTCP2 motors shipped with a shaft lock in place, remove the shaft lock after the motor is installed and before coupling and turning the shaft.

SPECIFICATIONS – CAST-IRON T-FRAME AND TC-FRAME MOTOR – 60HZ / 1800 RPM (50HZ / 1500 RPM)

Motor Specifications Premium-Efficiency T & TC Frame Three-Phase Motors 60Hz / 1800 rpm (50Hz / 1500 rpm)										
Part Number	HP ⁽²⁾	NEMA Frame	Voltage @ 60Hz (50Hz)	Housing	Shaft Material	Conduit Box Location (1)	Holes / Foot	Service Factor (3) (@ 50Hz)	F.L. Amps @ 208-230V/460V	Product Weight (lb)
MTCP2-001-3BD18	1	143T	208-230/460 – 3-phase (200/400 – 3-phase)	TEFC cast iron	1045 carbon steel	F1 (F2)	2	1.25 (1.0)	3.61-3.27 / 1.63	41
MTCP2-001-3BD18C		143TC								
MTCP2-1P5-3BD18	1-1/2	145T					4		4.92-4.45 / 2.22	56
MTCP2-1P5-3BD18C		145TC								
MTCP2-002-3BD18	2	145T					2		6.56-5.93 / 2.97	58.5
MTCP2-002-3BD18C		145TC								
MTCP2-003-3BD18	3	182T				2	9.01-8.16 / 4.08		86	
MTCP2-003-3BD18C		182TC								
MTCP2-005-3BD18	5	184T				F1	4		13.9-12.6 / 6.3	104
MTCP2-005-3BD18C		184TC								
MTCP2-7P5-3BD18	7-1/2	213T				F1 (F2)	2		20.4-18.5 / 9.23	172
MTCP2-7P5-3BD18C		213TC								

1) F1(F2) indicates F1 conduit box mounting location, field convertible to F2 (as shown on dimensional diagram).

2) For warranty on motors 50 hp and above, motors must be inspected by an EASA motor repair or service center. See AutomationDirect Terms & Conditions for details.

3) The service factor changes from 1.25 to 1.0 under the following conditions:

- When running the motor at 208VAC @ 60Hz
- When running the motor at 200/400VAC @ 50Hz
- When used with a VFD

***** Table Continued Next Page (for 10–300 hp motors) *****

MTCP2 PREMIUM-EFFICIENCY CAST-IRON THREE-PHASE MOTORS FEATURES AND SPECIFICATIONS (CONTINUED)

SPECIFICATIONS – CAST-IRON T-FRAME AND TC-FRAME MOTOR – 60HZ / 1800 RPM (50HZ / 1500 RPM)

***** Table Continued From Previous Page (for 1–7.5hp motors) *****

Motor Specifications Premium-Efficiency T & TC Frame Three-Phase Motors 60Hz / 1800 rpm (50Hz / 1500 rpm)																																						
Part Number	HP (2)	NEMA Frame	Voltage @ 60Hz (50Hz)	Housing	Shaft Material	Conduit Box Location (1)	Holes / Foot	Service Factor (4) (@50Hz)	F.L. Amps @ 208-230V/460V	Product Weight (lb)																												
MTCP2-010-3BD18	10	215T	208-230/460 – 3-phase (200/400 – 3-phase)	TEFC cast iron	1045 carbon steel	F1 (F2)	4	1.25 (1.0)	26.9-24.3 / 12.2	193																												
MTCP2-010-3BD18C		215TC					2																															
MTCP2-015-3BD18	15	254T					TEFC cast iron		1045 carbon steel	F1 (F2)	2	1.25 (1.0)	40.0-36.2 / 18.1	265																								
MTCP2-015-3BD18C		254TC									4																											
MTCP2-020-3BD18	20	256T									TEFC cast iron		1045 carbon steel	F1 (F2)	4	1.25 (1.0)	52.4-47.4 / 23.7	304																				
MTCP2-020-3BD18C		256TC													2																							
MTCP2-025-3BD18	25	284T													TEFC cast iron		1045 carbon steel	F1 (F2)	2	1.25 (1.0)	65.1-58.8 / 29.4	385																
MTCP2-025-3BD18C		284TC																	4																			
MTCP2-030-3BD18	30	286T																	TEFC cast iron		1045 carbon steel	F1 (F2)	4	1.25 (1.0)	78.1-70.6 / 35.3	430												
MTCP2-030-3BD18C		286TC																					2															
MTCP2-040-3BD18	40	324T																					TEFC cast iron		1045 carbon steel	F1 (F2)	2	1.25 (1.0)	104-93.7 / 46.8	531								
MTCP2-050-3BD18(2)	50	326T																									4											
MTCP2-060-3BD18(2)	60	364T																									TEFC cast iron		1045 carbon steel	F1 (F2)	2	1.25 (1.0)	158-142 / 71.2	769				
MTCP2-075-3BD18(2)	75	365T																													4							
MTCP2-100-3BD18(2)	100	405T																													TEFC cast iron		1045 carbon steel	F1 (F2)	4	1.25 (1.0)	252-228 / 114	1131
MTCP2-125-3BD18(2)	125	444T																																	2			
MTCP2-150-3BD18(2)	150	445T	TEFC cast iron	1045 carbon steel	F1 (F2)	4		1.25 (1.0)																											323-292 / 146		1429	
MTCP2-200-3BD18(2)	200	445/7T				4																																
MTCP2-250-3D18(2)	250	449T				460V	4140 carbon steel		F1	2		1.15																							280 (3)		2508	
MTCP2-300-3D18(2)	300	449T								2																									336 (3)		2728	

1) F1(F2) indicates F1 conduit box mounting location, field convertible to F2 (as shown on dimensional diagram).

2) For warranty on motors 50 hp and above, motors must be inspected by an EASA motor repair or service center. See AutomationDirect Terms & Conditions for details.

3) F.L. Amps @460V only.

4) The service factor changes from 1.25 to 1.0 under the following conditions:

- When running the motor at 208VAC @ 60Hz
- When running the motor at 200/400VAC @ 50Hz
- When used with a VFD

MTCP2 PREMIUM-EFFICIENCY CAST-IRON THREE-PHASE MOTORS FEATURES AND SPECIFICATIONS (CONTINUED)

**SPECIFICATIONS – CAST-IRON T-FRAME AND TC-FRAME MOTOR
– 60Hz / 1200 & 3600 RPM (50Hz / 1500 RPM)**

Motor Specifications Premium Efficiency T-Frame Three-Phase Motors 60Hz / 1200 & 3600 rpm (50Hz / 1000 & 3000 rpm)										
Part Number	HP	NEMA Frame	Voltage @ 60Hz (50Hz)	Housing	Shaft Material	Conduit Box Location (1)	Holes / Foot	Service Factor (2) (@50Hz)	F.L. Amps @ 208-230V/460V	Product Weight (lb)
1200 rpm Base Speed @ 60Hz (1000 rpm Base Speed @ 50Hz)										
MTCP2-001-3BD12	1	145T	208-230/460 – 3-phase (200/400 – 3-phase)	TEFC cast iron	1045 carbon steel	F1 (F2)	4	1.25 (1.0)	3.86-3.49 / 1.75	53
MTCP2-1P5-3BD12	1-1/2	182T					2		5.22-4.72 / 2.36	91.5
MTCP2-002-3BD12	2	184T					4		6.59-5.96 / 2.98	100
MTCP2-003-3BD12	3	213T					2		9.92-8.97 / 4.48	166
MTCP2-005-3BD12	5	215T					4		16.1-14.5 / 7.27	179
MTCP2-7P5-3BD12	7-1/2	254T					2		20.8-18.8 / 9.41	247
MTCP2-010-3BD12	10	256T					4		27.8-25.1 / 12.5	258
MTCP2-015-3BD12	15	284T					2		42.9-38.8 / 19.4	366
MTCP2-020-3BD12	20	286T					4		56.5-51.1 / 25.5	419
3600 rpm Base Speed (3000 rpm Base Speed @ 50Hz)										
MTCP2-1P5-3BD36	1-1/2	143T	208-230/460 – 3-phase (200/400 – 3-phase)	TEFC cast iron	1045 carbon steel	F1	2	1.25 (1.0)	4.62-4.18 / 2.09	45.2
MTCP2-002-3BD36	2	145T				(F2)	4		6.05-5.48 / 2.74	50.7
MTCP2-003-3BD36	3	182T				F1	2		6.45-7.64 / 3.82	80.5
MTCP2-005-3BD36	5	184T				4	13.3-12.0 / 6.01		96	
MTCP2-7P5-3BD36	7-1/2	213T				2	20.9-18.9 / 9.45		160	
MTCP2-010-3BD36	10	215T				F1	4		27.0-24.4 / 12.2	180
MTCP2-015-3BD36	15	254T				(F2)	2		38.8-35.1 / 17.5	261
MTCP2-020-3BD36	20	256T				4	51.1-46.2 / 23.1		297	
1) F1(F2) indicates F1 conduit box mounting location, field convertible to F2 (as shown on dimensional diagram). 2) The service factor changes from 1.25 to 1.0 under the following conditions: <ul style="list-style-type: none"> • When running the motor at 208VAC @ 60Hz • When running the motor at 200/400VAC @ 50Hz • When used with a VFD 										

MTCP2 PREMIUM-EFFICIENCY CAST-IRON THREE-PHASE MOTORS FEATURES AND SPECIFICATIONS (CONTINUED)

PERFORMANCE DATA – CAST-IRON T-FRAME AND TC-FRAME MOTOR – 60Hz / 1800 RPM

Performance Data @ 60Hz Premium-Efficiency T & TC Frame Three-Phase Motors – 1800 rpm (460 Volt except as indicated)										
Part Number	HP	NEMA Design	F.L. RPM	Minimum Speed (rpm)		Maximum Speed (rpm)		F.L. Efficiency (%)	F.L. Power Factor	Rotor Inertia (lb·ft ²)
				CT (10:1)	VT (20:1)	CHP	Safe			
MTCP2-001-3BD18(C)	1	B	1755	175.5	87.75	2700	3600	85.5	0.67	0.089
MTCP2-1P5-3BD18(C)	1-1/2		1755	175.5	87.75		3600	86.5	0.73	0.105
MTCP2-002-3BD18(C)	2		1755	175.5	87.75		3600	86.5	0.73	0.116
MTCP2-003-3BD18(C)	3		1755	175.5	87.75		3600	89.5	0.77	0.23
MTCP2-005-3BD18(C)	5		1755	175.5	87.75		3600	89.5	0.83	0.326
MTCP2-7P5-3BD18(C)	7-1/2		1760	176	88		3600	91.7	0.83	0.689
MTCP2-010-3BD18(C)	10		1760	176	88		3600	91.7	0.84	0.814
MTCP2-015-3BD18(C)	15		1765	176.5	88.25		3600	92.4	0.84	1.89
MTCP2-020-3BD18(C)	20		1765	176.5	88.25		3600	93	0.85	2.33
MTCP2-025-3BD18(C)	25		1770	177	88.5		2700	93.6	0.85	3.36
MTCP2-030-3BD18(C)	30		1770	177	88.5		2700	93.6	0.85	3.83
MTCP2-040-3BD18	40		1775	177.5	88.75		2700	94.1	0.85	6.11
MTCP2-050-3BD18	50		1775	177.5	88.75		2700	94.5	0.86	6.89
MTCP2-060-3BD18	60		1780	178	89		2700	95	0.83	14.7
MTCP2-075-3BD18	75		1780	178	89		2700	95.4	0.83	17.5
MTCP2-100-3BD18	100		1785	178.5	89.25		2700	95.4	0.86	31.2
MTCP2-125-3BD18	125		1790	179	89.5		2700	95.4	0.84	40.1
MTCP2-150-3BD18	150		1790	179	89.5		2700	95.8	0.84	48.5
MTCP2-200-3BD18	200		1790	179	89.5		2250	96.2	0.85	64.3
MTCP2-250-3D18	250		1790	179	89.5		2250	96.2	0.87	78.8
MTCP2-300-3D18	300	1790	179	89.5	2250	96.2	0.87	94.1		

*** TABLE CONTINUED NEXT PAGE ***

MTCP2 PREMIUM-EFFICIENCY CAST-IRON THREE-PHASE MOTORS FEATURES AND SPECIFICATIONS (CONTINUED)

PERFORMANCE DATA – CAST-IRON T-FRAME AND TC-FRAME MOTOR – 60HZ / 1800 RPM (CONTINUED)

***** Table Continued From Previous Page *****

Performance Data @ 60Hz Premium-Efficiency T & TC Frame Three-Phase Motors – 1800 rpm (460 Volt except as indicated)							
Part Number	HP	Current @ 230V/460V (Amps)			Torque (lb-ft)		
		No Load	Full Load	Locked Rotor	Full Load	Locked Rotor	Break-down
MTCP2-001-3BD18(C)	1	2.2/1.1	3.27/1.63	30/15	2.99	8.37	11.96
MTCP2-1P5-3BD18(C)	1-1/2	2.9/1.45	4.45/2.22	40/20	4.49	12.57	17.51
MTCP2-002-3BD18(C)	2	3.9/1.95	5.93/2.97	50/25	5.98	16.15	20.93
MTCP2-003-3BD18(C)	3	4.6/2.3	8.16/4.08	64/32	9	19.80	28.80
MTCP2-005-3BD18(C)	5	5.4/2.7	12.6/6.3	92/46	15	30.00	42.00
MTCP2-7P5-3BD18(C)	7-1/2	8.0/4.0	18.5/9.23	127/63.5	22.3	41.26	60.21
MTCP2-010-3BD18(C)	10	9.8/4.9	24.3/12.2	162/81	29.7	51.98	77.22
MTCP2-015-3BD18(C)	15	15/7.5	36.2/18.1	232/116	44.6	84.74	120.42
MTCP2-020-3BD18(C)	20	18/9	47.4/23.7	290/145	59.5	107.10	148.75
MTCP2-025-3BD18(C)	25	21.2/10.6	58.8/29.4	365/182.5	74.2	111.30	178.08
MTCP2-030-3BD18(C)	30	24/12	70.6/35.3	435/217.5	89	133.50	213.60
MTCP2-040-3BD18	40	34/17	93.7/46.8	580/290	118	188.80	306.80
MTCP2-050-3BD18	50	41/20.5	115/57.6	725/362.5	148	236.80	384.80
MTCP2-060-3BD18	60	56/28	142/71.2	870/435	177	362.85	442.50
MTCP2-075-3BD18	75	74/37	177/88.7	1085/542.5	221	397.80	508.30
MTCP2-100-3BD18	100	70/35	228/114	1450/725	294	470.40	735.00
MTCP2-125-3BD18	125	104/52	292/146	1815/907	367	587.20	880.80
MTCP2-150-3BD18	150	113/56.5	349/175	2170/1085	440	704.00	1056.00
MTCP2-200-3BD18	200	144/72	458/229	2900/1450	587	997.90	1467.50
MTCP2-250-3D18 ¹⁾	250	91.9 ⁽¹⁾	280 ⁽¹⁾	1825 ⁽¹⁾	773	1546.00	2009.80
MTCP2-300-3D18 ¹⁾	300	103 ⁽¹⁾	336 ⁽¹⁾	2200 ⁽¹⁾	880	1760.00	2200.00

1) Current @460V (Amps) only.

*** TABLE CONTINUED NEXT PAGE ***

MTCP2 PREMIUM-EFFICIENCY CAST-IRON THREE-PHASE MOTORS FEATURES AND SPECIFICATIONS (CONTINUED)

PERFORMANCE DATA – CAST-IRON T-FRAME AND TC-FRAME MOTOR – 60Hz / 1800 RPM (CONTINUED)

***** Table Continued From Previous Page *****

Performance Data @ 60Hz Premium-Efficiency T & TC Frame Three-Phase Motors 1800 rpm – (460 Volt except as indicated)				
Part Number	HP	Slip (%)	Max Time @ Locked Rotor Current (hot) (seconds)	Temperature Rise @ Full Load
MTCP2-001-3BD18(C)	1	2.5	12	80°C [176°F]
MTCP2-1P5-3BD18(C)	1-1/2	2.5	10	
MTCP2-002-3BD18(C)	2	2.5	12	
MTCP2-003-3BD18(C)	3	2.5	12	
MTCP2-005-3BD18(C)	5	2.5	10	
MTCP2-7P5-3BD18(C)	7-1/2	1.94	14	
MTCP2-010-3BD18(C)	10	1.94	12	
MTCP2-015-3BD18(C)	15	1.94	13	
MTCP2-020-3BD18(C)	20	1.94	12	
MTCP2-025-3BD18(C)	25	1.67	16	
MTCP2-030-3BD18(C)	30	1.67	14	
MTCP2-040-3BD18	40	1.40	12	
MTCP2-050-3BD18	50	1.40	7	
MTCP2-060-3BD18	60	1.10	16	
MTCP2-075-3BD18	75	1.10	12	
MTCP2-100-3BD18	100	0.83	10	
MTCP2-125-3BD18	125	0.55	11	
MTCP2-150-3BD18	150	0.55	12	
MTCP2-200-3BD18	200	0.55	10	
MTCP2-250-3D18	250	0.56	12	
MTCP2-300-3D18	300	0.56	14	

MTCP2 PREMIUM-EFFICIENCY THREE-PHASE MOTORS FEATURES & SPECS (CONTINUED)

PERFORMANCE DATA – CAST-IRON T-FRAME MOTOR – 60HZ / 1200 RPM

Performance Data @ 60Hz – Premium Efficiency T-Frame 3-Phase Motors – 1200 rpm – (460 Volt except as indicated)							
Part Number	HP	NEMA Design	F.L. RPM	Minimum Speed (rpm)		Maximum Speed (rpm)	
				Constant Torque (10:1)	Variable Torque (20:1)	CHP	Safe
MTCP2-001-3BD12	1	B	1160	116	58	1800	2400
MTCP2-1P5-3BD12	1-1/2		1180	118	59		
MTCP2-002-3BD12	2		1175	118	59		
MTCP2-003-3BD12	3		1175	117.5	58.75		
MTCP2-005-3BD12	5		1175	117.5	58.75		
MTCP2-7P5-3BD12	7-1/2		1175	117.5	58.75		
MTCP2-010-3BD12	10		1175	117.5	58.75		
MTCP2-015-3BD12	15		1185	118.5	59.25		
MTCP2-020-3BD12	20		1185	118.5	59.25		
Part Number	HP	Current @ 230V/460V (Amps)			Torque (lb-ft)		
		No Load	Full Load	Locked Rotor	Full Load	Locked Rotor	Break-down
MTCP2-001-3BD12	1	2.3/1.5	3.49/1.75	30/15	4.53	8.15	12.00
MTCP2-1P5-3BD12	1-1/2	3.1/1.55	4.72/2.36	40/20	6.67	16.68	24.01
MTCP2-002-3BD12	2	3.7/1.85	5.96/2.98	50/25	8.9	20.47	29.37
MTCP2-003-3BD12	3	5/2.5	8.97/4.48	64/32	13.3	20.62	31.92
MTCP2-005-3BD12	5	7.1/3.55	14.5/7.27	92/46	22.2	35.52	53.28
MTCP2-7P5-3BD12	7-1/2	8.4/4.2	18.8/9.41	127/63.5	33.5	60.30	93.80
MTCP2-010-3BD12	10	11.6/5.8	25.1/12.5	162/81	44.7	80.46	125.16
MTCP2-015-3BD12	15	17/8.5	38.8/19.4	232/116	66.5	96.43	152.95
MTCP2-020-3BD12	20	49.2/24.6	51.1.2/25.5	290/145	88.6	124.04	194.92
Part Number	HP	Temperature Rise @ Full Load	Max Time Locked Rotor (Hot) (seconds)	F.L. Efficiency (%)	F.L. Power Factor	Rotor Inertia (lb-ft ²)	Slip (%)
MTCP2-001-3BD12	1	80°C [176°F]	18	82.5	0.65	0.118	3.3
MTCP2-1P5-3BD12	1-1/2		8	86.8	0.68	0.401	1.67
MTCP2-002-3BD12	2		8	88.5	0.71	0.462	1.67
MTCP2-003-3BD12	3		26	89.5	0.7	0.646	1.67
MTCP2-005-3BD12	5		22	89.5	0.72	0.946	1.67
MTCP2-7P5-3BD12	7-1/2		22	91	0.82	2.03	2.08
MTCP2-010-3BD12	10		12	91	0.82	2.27	2.10
MTCP2-015-3BD12	15		10	91.7	0.79	4.09	1.25
MTCP2-020-3BD12	20		8	91.7	0.80	5	1.25

MTCP2 PREMIUM-EFFICIENCY THREE-PHASE MOTORS FEATURES & SPECS (CONTINUED)

PERFORMANCE DATA – CAST-IRON T-FRAME MOTOR – 60Hz / 3600 RPM

Performance Data @ 60Hz – Premium Efficiency T-Frame 3-Phase Motors – 3600 rpm – (460 Volt except as indicated)							
Part Number	HP	NEMA Design	F.L. RPM	Minimum Speed (rpm)		Maximum Speed (rpm)	
				Constant Torque (10:1)	Variable Torque (20:1)	CHP	Safe
MTCP2-1P5-3BD36	1-1/2	B	3490	348.5	174.25	5400	7200
MTCP2-002-3BD36	2		3495	349	174.5		
MTCP2-003-3BD36	3		3490	350.5	175.25		
MTCP2-005-3BD36	5		3490	350.5	175.25		
MTCP2-7P5-3BD36	7-1/2		3505	350.5	175.25	5400	5400
MTCP2-010-3BD36	10		3500	350	175		
MTCP2-015-3BD36	15		3540	354.5	177.25		
MTCP2-020-3BD36	20		3540	354	177		
Part Number	HP	Current @ 230V/460V (Amps)			Torque (lb-ft)		
		No Load	Full Load	Locked Rotor	Full Load	Locked Rotor	Break-down
MTCP2-1P5-3BD36	1-1/2	2.1/1.05	4.18/2.09	40/20	2.26	4.97	7.01
MTCP2-002-3BD36	2	2.5/1.25	5.48/2.74	50/25	3.01	6.92	9.63
MTCP2-003-3BD36	3	3.52/1.7	7.64/3.82	64/32	4.49	9.43	15.72
MTCP2-005-3BD36	5	3.1/1.55	12.0/6.01	92/46	7.49	16.48	26.22
MTCP2-7P5-3BD36	7-1/2	6.4/3.2	18.9/9.45	127/63.5	11.2	17.92	33.60
MTCP2-010-3BD36	10	7.3/3.7	24.4/12.2	162/81	14.9	22.35	41.72
MTCP2-015-3BD36	15	9.8/4.9	35.1/17.5	232/116	22.2	37.74	55.50
MTCP2-020-3BD36	20	46.2/23.1	46.2/23.1	290/145	29.7	47.52	68.31
Part Number	HP	Temperature Rise @ Full Load	Max Time Locked Rotor (Hot) (seconds)	F.L. Efficiency (%)	F.L. Power Factor	Rotor Inertia (lb-ft ²)	Slip (%)
MTCP2-1P5-3BD36	1-1/2	80°C [176°F]	8	84	0.80	0.043	3.2
MTCP2-002-3BD36	2		6	85.5	0.80	0.05	3.05
MTCP2-003-3BD36	3		8	86.5	0.85	0.133	2.64
MTCP2-005-3BD36	5		7	88.5	0.88	0.178	2.64
MTCP2-7P5-3BD36	7-1/2		26	89.5	0.83	11.2	2.36
MTCP2-010-3BD36	10		20	90.2	0.85	0.369	2.22
MTCP2-015-3BD36	15		15	91	0.88	1.06	1.53
MTCP2-020-3BD36	20		12	91	0.89	1.26	1.66

MTCP2 PREMIUM-EFFICIENCY CAST-IRON THREE-PHASE MOTORS FEATURES AND SPECIFICATIONS (CONTINUED)

PERFORMANCE DATA – CAST-IRON T-FRAME AND TC-FRAME MOTOR – 50Hz / 1500RPM

Performance Data @ 50Hz Premium-Efficiency T & TC Frame Three-Phase Motors – 1500 rpm (400 Volt except as indicated)										
Part Number	HP	NEMA Design	F.L. RPM	Minimum Speed (rpm)		Maximum Speed (rpm)		F.L. Efficiency (%)	F.L. Power Factor	Rotor Inertia (lb-ft ²)
				CT (10:1)	VT (20:1)	CHP	Safe			
MTCP2-001-3BD18(C)	1	B	1450	146	73	2700	3600	79.6	0.67	0.089
MTCP2-1P5-3BD18(C)	1-1/2		1450				3600	81.4	0.73	0.105
MTCP2-002-3BD18(C)	2		1450				3600	82.8	0.73	0.116
MTCP2-003-3BD18(C)	3		1450				3600	84.3	0.77	0.23
MTCP2-005-3BD18(C)	5		1450				3600	86.6	0.83	0.326
MTCP2-7P5-3BD18(C)	7-1/2		1455	146.5	73.25		3600	87.7	0.83	0.689
MTCP2-010-3BD18(C)	10		1455				3600	88.7	0.84	0.814
MTCP2-015-3BD18(C)	15		1460	147	73.5		3600	89.8	0.84	1.89
MTCP2-020-3BD18(C)	20		1460				3600	90.6	0.85	2.33
MTCP2-025-3BD18(C)	25		1465	147.5	73.75		2700	91.2	0.85	3.36
MTCP2-030-3BD18(C)	30		1465				2700	91.6	0.85	3.83
MTCP2-040-3BD18	40		1475	148	74		2700	92.3	0.85	6.11
MTCP2-050-3BD18	50		1475				2700	92.7	0.86	6.89
MTCP2-060-3BD18	60		1480				2700	93.1	0.83	14.7
MTCP2-075-3BD18	75		1480				2700	93.5	0.83	17.5
MTCP2-100-3BD18	100		1485				148.5	74.25	2700	94.0
MTCP2-125-3BD18	125		1490	149	74.5		2700	94.2	0.84	40.1
MTCP2-150-3BD18	150		1490				2700	94.5	0.84	48.5
MTCP2-200-3BD18	200		1490				2250	94.9	0.85	64.3
MTCP2-250-3D18	250		n/a							
MTCP2-300-3D18	300	n/a								

*** TABLE CONTINUED NEXT PAGE ***

MTCP2 PREMIUM-EFFICIENCY CAST-IRON THREE-PHASE MOTORS FEATURES AND SPECIFICATIONS (CONTINUED)

PERFORMANCE DATA – CAST-IRON T-FRAME AND TC-FRAME MOTOR – 50Hz / 1500RPM (CONTINUED)

***** Table Continued From Previous Page *****

Performance Data @ 50Hz Premium-Efficiency T & TC Frame Three-Phase Motors – 1500 rpm (400 Volt except as indicated)							
Part Number	HP	Current @ 200V/400V (Amps)			Torque (lb-ft)		
		No Load	Full Load	Locked Rotor	Full Load	Locked Rotor	Break -down
MTCP2-001-3BD18(C)	1	2.54/1.27	4.04/2.02	26.3/13.1	2.99	9.41	12.7
MTCP2-1P5-3BD18(C)	1-1/2	3.10/1.55	5.44/2.72	31.6/15.8	4.49	13.0	17.4
MTCP2-002-3BD18(C)	2	4.24/2.12	7.13/3.56	43.9/21.9	5.98	16.7	22.4
MTCP2-003-3BD18(C)	3	5.56/2.78	9.95/4.98	61.6/30.8	9	20.6	30.4
MTCP2-005-3BD18(C)	5	5.86/2.93	15.0/7.49	89.6/44.8	15	31.7	48.0
MTCP2-7P5-3BD18(C)	7-1/2	8.40/4.2	22.2/11.1	127/63.4	22.3	40.6	64.9
MTCP2-010-3BD18(C)	10	10.6/5.3	28.9/14.5	172/85.9	29.7	54.1	93.8
MTCP2-015-3BD18(C)	15	17.0/8.5	42.8/21.4	225/112	44.6	80.9	119
MTCP2-020-3BD18(C)	20	19.0/9.5	55.9/28.0	289/144	59.5	108	158
MTCP2-025-3BD18(C)	25	24.0/12	69.5/34.7	370/185	74.2	130	197
MTCP2-030-3BD18(C)	30	30.0/15	83.0/41.5	467/233	89	156	237
MTCP2-040-3BD18	40	39.0/19.5	110/54.9	612/306	118	221	313
MTCP2-050-3BD18	50	46.0/23	135/67.5	757/378	148	276	409
MTCP2-060-3BD18	60	55.0/27.5	167/83.6	1044/522	177	362	490
MTCP2-075-3BD18	75	68.0/34	208/104	1082/541	221	452	612
MTCP2-100-3BD18	100	76.0/38	266/133	1534/767	294	530	778
MTCP2-125-3BD18	125	110/55	340/170	1699/850	367	573	881
MTCP2-150-3BD18	150	126/63	407/203	2107/1054	440	687	1110
MTCP2-200-3BD18	200	160/80	534/267	2834/1417	587	916	1480
MTCP2-250-3D18	250	n/a					
MTCP2-300-3D18	300	n/a					

*** TABLE CONTINUED NEXT PAGE ***

MTCP2 PREMIUM-EFFICIENCY CAST-IRON THREE-PHASE MOTORS FEATURES AND SPECIFICATIONS (CONTINUED)

PERFORMANCE DATA – CAST-IRON T-FRAME AND TC-FRAME MOTOR – 50Hz / 1500 RPM (CONTINUED)

***** Table Continued From Previous Page *****				
Performance Data @ 50Hz Premium-Efficiency T & TC Frame Three-Phase Motors 1500 rpm – (400 Volt except as indicated)				
Part Number	HP	Slip (%)	Max Time @ Locked Rotor Current (hot)	Temperature Rise @ Full Load
MTCP2-001-3BD18(C)	1	2.5	12	80°C [176°F]
MTCP2-1P5-3BD18(C)	1-1/2	2.5	10	
MTCP2-002-3BD18(C)	2	2.5	12	
MTCP2-003-3BD18(C)	3	2.5	12	
MTCP2-005-3BD18(C)	5	2.5	10	
MTCP2-7P5-3BD18(C)	7-1/2	1.94	14	
MTCP2-010-3BD18(C)	10	1.94	12	
MTCP2-015-3BD18(C)	15	1.94	13	
MTCP2-020-3BD18(C)	20	1.94	12	
MTCP2-025-3BD18(C)	25	1.67	16	
MTCP2-030-3BD18(C)	30	1.67	14	
MTCP2-040-3BD18	40	1.40	12	
MTCP2-050-3BD18	50	1.40	7	
MTCP2-060-3BD18	60	1.10	16	
MTCP2-075-3BD18	75	1.10	12	
MTCP2-100-3BD18	100	0.83	10	
MTCP2-125-3BD18	125	0.55	11	
MTCP2-150-3BD18	150	0.55	12	
MTCP2-200-3BD18	200	0.55	10	
MTCP2-250-3D18	250	n/a		
MTCP2-300-3D18	300	n/a		

MTCP2 PREMIUM-EFFICIENCY CAST-IRON THREE-PHASE MOTORS FEATURES & SPECS (CONTINUED)

PERFORMANCE DATA – CAST-IRON T-FRAME MOTOR – 50Hz / 1000 RPM

Performance Data @ 50Hz – Premium Efficiency T-Frame 3-Phase Motors – 1000 rpm – (400 Volt except as indicated)							
Part Number	HP	NEMA Design	F.L. RPM	Minimum Speed (rpm)		Maximum Speed (rpm)	
				Constant Torque (10:1)	Variable Torque (20:1)	CHP	Safe
MTCP2-001-3BD12	1	B	955	96.5	48.25	1800	2400
MTCP2-1P5-3BD12	1-1/2		970	98	49		
MTCP2-002-3BD12	2		970				
MTCP2-003-3BD12	3		970				
MTCP2-005-3BD12	5		970				
MTCP2-7P5-3BD12	7-1/2		970	97.5	48.25		
MTCP2-010-3BD12	10		970				
MTCP2-015-3BD12	15		980	98.5	49.25		
MTCP2-020-3BD12	20		980				
Part Number	HP		Current @ 200V/400V (Amps)				
		No Load	Full Load	Locked Rotor	Full Load	Locked Rotor	Break-down
MTCP2-001-3BD12	1	2.76/1.38	4.37/2.18	18/9.13	4.53	9.90	13.2
MTCP2-1P5-3BD12	1-1/2	3.34/1.67	6.08/3.04	32/16.2	6.67	14.6	22.7
MTCP2-002-3BD12	2	3.80/1.9	7.60/3.80	39/19.5	8.9	18.4	28.1
MTCP2-003-3BD12	3	5.50/2.75	11.3/5.64	54/27.1	13.3	24.4	37.3
MTCP2-005-3BD12	5	7.60/3.8	17.7/8.84	79/39.4	22.2	39.2	59.5
MTCP2-7P5-3BD12	7-1/2	9.00/4.5	22.9/11.5	106/53.2	33.5	58.9	97.4
MTCP2-010-3BD12	10	12.8/6.4	30.11/15.1	158/79.1	44.7	81.2	130
MTCP2-015-3BD12	15	20.0/10	46.1/23.7	231/116	66.5	113	169
MTCP2-020-3BD12	20	25.0/12.5	60.0/30.0	292/146	88.6	139	204
Part Number	HP	Temperature Rise @ Full Load	Max Time Locked Rotor (Hot)	F.L. Efficiency (%)	F.L. Power Factor	Rotor Inertia (lb-ft ²)	Slip (%)
MTCP2-001-3BD12	1	80°C [176°F]	18	75.9	0.65	0.118	3.3
MTCP2-1P5-3BD12	1-1/2		8	78.1	0.68	0.401	1.67
MTCP2-002-3BD12	2		8	79.8	0.71	0.462	1.67
MTCP2-003-3BD12	3		26	81.8	0.70	0.646	1.67
MTCP2-005-3BD12	5		22	84.6	0.72	0.946	1.67
MTCP2-7P5-3BD12	7-1/2		22	86.0	0.82	2.03	2.08
MTCP2-010-3BD12	10		12	87.2	0.82	2.27	2.10
MTCP2-015-3BD12	15		10	88.7	0.79	4.09	1.25
MTCP2-020-3BD12	20		8	89.7	0.80	5	1.25

MTCP2 PREMIUM-EFFICIENCY CAST-IRON THREE-PHASE MOTORS FEATURES & SPECS (CONTINUED)

PERFORMANCE DATA – CAST-IRON T-FRAME MOTOR – 50Hz / 3000 RPM

Performance Data @ 50Hz – Premium Efficiency T-Frame 3-Phase Motors – 3000 rpm – (400 Volt except as indicated)							
Part Number	HP	NEMA Design	F.L. RPM	Minimum Speed (rpm)		Maximum Speed (rpm)	
				Constant Torque (10:1)	Variable Torque (20:1)	CHP	Safe
MTCP2-1P5-3BD36	1-1/2	B	2875	290	145	5400	7200
MTCP2-002-3BD36	2		2880	290.5	145.25		
MTCP2-003-3BD36	3		2885	292	146		
MTCP2-005-3BD36	5		2885				
MTCP2-7P5-3BD36	7-1/2		2900	2900	291.5	145.75	5400
MTCP2-010-3BD36	10		2900	291.5	145.75		
MTCP2-015-3BD36	15		2935	295.5	147.75		
MTCP2-020-3BD36	20		2935	295	147.5		
Part Number	HP	Current @ 200V/400V (Amps)			Torque (lb-ft)		
		No Load	Full Load	Locked Rotor	Full Load	Locked Rotor	Break-down
MTCP2-1P5-3BD36	1-1/2	3.46/1.73	5.07/2.54	44.1/22.1	2.26	7.29	10.21
MTCP2-002-3BD36	2	3.46/1.73	6.62/3.31	44.1/22.1	3.01	7.29	10.21
MTCP2-003-3BD36	3	3.90/1.95	9.14/4.57	50.5/25.3	4.49	9.28	14.7
MTCP2-005-3BD36	5	4.70/2.35	14.3/7.13	87.7/43.9	7.49	16.4	24.6
MTCP2-7P5-3BD36	7-1/2	7.40/3.7	22.4/11.2	127/63.5	11.2	19.7	33.9
MTCP2-010-3BD36	10	9.20/4.6	28.8/14.4	151/75.5	14.9	26.3	45.3
MTCP2-015-3BD36	15	10.2/5.1	41.1/20.5	201/101	22.2	34.9	53.7
MTCP2-020-3BD36	20	12.0/6	53.6/26.8	280/140	29.7	46.5	71.6
Part Number	HP	Temperature Rise @ Full Load	Max Time Locked Rotor (Hot)	F.L. Efficiency (%)	F.L. Power Factor	Rotor Inertia (lb-ft ²)	Slip (%)
MTCP2-1P5-3BD36	1-1/2	80°C [176°F]	8	81.3	0.80	0.043	3.2
MTCP2-002-3BD36	2		6	81.3	0.80	0.05	3.05
MTCP2-003-3BD36	3		8	83.2	0.85	0.133	2.64
MTCP2-005-3BD36	5		7	85.8	0.88	0.178	2.64
MTCP2-7P5-3BD36	7-1/2		26	87.0	0.83	11.2	2.36
MTCP2-010-3BD36	10		20	88.1	0.85	0.369	2.22
MTCP2-015-3BD36	15		15	89.4	0.88	1.06	1.53
MTCP2-020-3BD36	20		12	90.3	0.89	1.26	1.66

RECEIVING AND INSPECTION

UNPACKING

After receiving an IronHorse motor, please check for the following:

- Open the motor packaging and inspect for damage during shipment.
- Make sure the part number indicated on the motor nameplate corresponds with the part number on your order.
- For all 56C and 56HC framed motors, make sure that the shipment contains the motor, the removable mounting foot and mounting foot bolts.
- Read the enclosed Product Advisory.

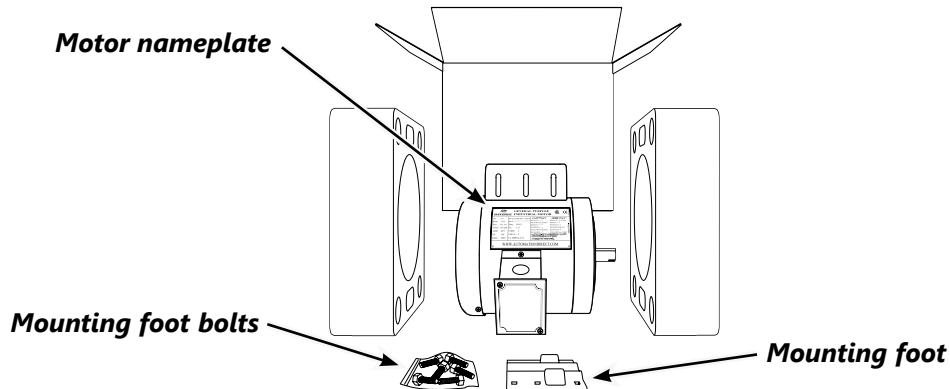

IRONHORSE® PART NUMBER EXPLANATION

MT CP - 7P5 - 3 BD 18 C - 14

■ **Additional Frame Size**

Blank: Standard Frame
 14: 143/145 Frame
 18: 182/184 Frame

■ **Optional Identifier**

C: C-face cast-iron motor
 R: Round body (no mounting feet)

■ **Nominal RPM**

12: 1200 rpm
 18: 1800 rpm
 36: 3600 rpm

■ **Voltage Class (multiple letters possible)**

A: 115 VAC	D: 460 VAC
B: 208-230 VAC	L: 90 VDC
C: 230 VAC	M: 180 VDC

■ **Phase**

1: Single phase
 3: Three phase

■ **Rated Horsepower**

P: Decimal Point
 # left of P: Rated full hp
 # right of P: Rated fractional hp

■ **Motor type**

A: Motor Accessory
 AP: Motor Accessory for Premium-efficiency motor
 C: AC EPAct motor with Cast-iron frame
 CP2: AC Premium-efficiency motor with Cast-iron frame
 DP: Open Drip Proof

F(2): Farm Duty
 R(2): AC Motor w Rolled-steel frame
 RP: AC Premium-efficiency motor with Rolled-steel frame
 PM: DC Permanent Magnet
 RJ(P): Jet Pump
 SS: AC Motor w Stainless-steel frame
 SP: AC Motor IP69K SS TEFC
 SN: AC Motor IP69K SS TENV

■ **IronHorse Motors Series Designation**

RESHIPING

If an IronHorse motor needs to be reshipped from the initial shipping point, the following procedures should be followed to protect the motor from damage.

- 1) If the original packaging is to be used for reshipment, inspect the packaging for previous shipping damage and repackage if necessary. Take care to protect the motor body, fan cover and shaft.
- 2) It is a good idea to bolt the motor to a platform that fits securely in the bottom of the shipping crate or box. This helps prevent the motor from shifting during transport and thus protects the bearings from damage.
- 3) A shaft lock device should be installed on motors from 100 to 300 hp prior to shipment. The shaft lock helps prevent bearing damage.
- 4) Motors should only be lifted by the the eyebolt(s) provided on the motor. When lifting motors with more than one eyebolt, use every bolt provided.

LONG TERM STORAGE

The following preventative measures should be taken when storing IronHorse motors for a long period of time.

- 1) Store motors in a controlled temperature, dry atmosphere free of excess dirt, dust and airborne particles.
- 2) Rotate the motor shaft every sixty days to prevent hardening of the bearing grease.
- 3) Warehoused motors should have the bearing grease purged and replaced every six months. Use only Mobil POLYREX® EM Polyurea grease. For MTCP2 motors, use SKF, LGHP2 grease. For MTF2 and MTDP motors, use Multemp, SRL grease or equivalent.

WARRANTY

- *IronHorse MTSS stainless steel motors carry a one year warranty from the date of invoice.*
- *All other IronHorse motors (except MTSS) carry a two year warranty from the date of invoice.*

For motors 40hp and smaller, valid warranty claims will be resolved by product replacement. Motors 50hp and larger must be evaluated by an authorized Electrical Apparatus Service Association (EASA) service center. Valid warranty claims will be resolved by repair or replacement at the discretion of AutomationDirect. See AutomationDirect Terms and Conditions in our current catalog or online at <http://www.automationdirect.com/static/specs/adpolicy.pdf> for complete details.

Authorized EASA service centers are available nationwide. Visit the EASA website at www.easa.com to find the nearest authorized service center. These shops may also be able to assist with non-warranty service.

MOUNTING AND INITIAL STARTUP

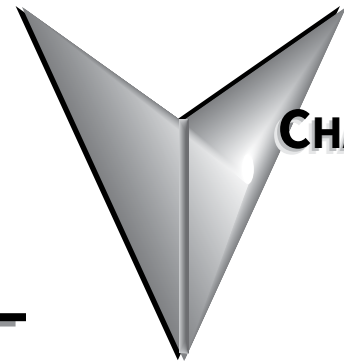

CHAPTER 2

TABLE OF CONTENTS

<i>Safety Information</i>2-2
<i>Danger!</i>2-2
<i>Wiring Notes: PLEASE READ PRIOR TO INSTALLATION</i>	2-2
<i>Applicable Codes</i>	2-2
<i>Motor Dimensions</i>2-3
<i>(Dimensions = inches)</i>2-3
<i>MTF2 T-Frame Single-phase Farm-Duty Motor Dimensions</i>	2-3
<i>MTR2 56(H)C-Frame Single-phase Rolled-steel Motor Dimensions</i>	2-3
<i>MTR2 56C-Frame Three-phase Rolled-steel Motor Dimensions</i>	2-4
<i>MTRP 56HC-Frame Three-phase Rolled-steel Motor Dimensions</i>	2-5
<i>MTDP Open Drip-Proof Three-phase Rolled-steel Motor Dimensions</i>	2-6
<i>MTCP2 Premium-Efficiency T-Frame Three-Phase Motor Dimensions</i>	2-7
<i>MTCP2 Premium-Efficiency TC-Frame Three-Phase Motor Dimensions</i>2-11
<i>Terminal and Wiring Diagrams</i>	2-13
<i>IronHorse® Single-Phase Motors</i>2-13
<i>IronHorse® Three-Phase Motors</i>2-14
<i>Single-Phase Motors Reversing Diagrams</i>2-16
<i>Motor Mounting</i>	2-18
<i>General Mounting Information</i>2-18
<i>Motor Mounting Orientation</i>2-18
<i>Proper Installation Conditions</i>2-19
<i>Coupling Alignment</i>2-19
<i>Motor Nameplate & Starter Information</i>	2-20
<i>Typical IronHorse® Motor Nameplate</i>2-20
<i>Motor Starter Information</i>2-20
<i>Locked Rotor Amps</i>2-20
<i>Inspection Before Startup</i>	2-21
<i>Initial Startup Inspection</i>	2-21

SAFETY INFORMATION**DANGER!**

HAZARDOUS VOLTAGE! BEFORE MAKING ANY CONNECTION TO THE MOTOR, DISCONNECT ALL POWER TO THE MOTOR.



WARNING: ANY ELECTRICAL OR MECHANICAL MODIFICATION TO THIS EQUIPMENT WITHOUT PRIOR WRITTEN CONSENT OF AUTOMATIONDIRECT.COM, INC. WILL VOID ALL WARRANTIES, MAY RESULT IN A SAFETY HAZARD, AND MAY VOID THE cCSA_{US} OR cUR_{US} LISTING.



WARNING: TO AVOID PHYSICAL INJURY, KEEP YOUR HANDS AND CLOTHING AWAY FROM ALL MOVING PARTS.

WIRING NOTES: PLEASE READ PRIOR TO INSTALLATION.

- 1) During installation, follow all local electrical, construction, and safety codes for the country in which the motor is to be installed.
- 2) Make sure the appropriate protective devices (circuit breaker or fuses) are connected between the power source and motor controller.
- 3) Make sure that the leads are connected correctly and the motor is properly grounded. (Ground resistance should not exceed 0.1Ω.)
- 4) Use ground leads that comply with AWG/MCM standards and keep them as short as possible.
- 5) Make sure that the power source is capable of supplying the correct voltage and required current to the motor.
- 6) Do not attach or remove wiring when power is applied to the motor.

APPLICABLE CODES

Most IronHorse® motors are cCSA_{US} listed, and therefore comply with the requirements of the National Electrical Code (NEC) and the Canadian Electrical Code (CEC).

IronHorse MTDP, open drip proof and MTF2, farm duty motors are cUR_{US} recognized and comply with the requirements of the National Electrical Code (NEC) and the Canadian Electrical Code (CEC).

Because IronHorse, MTDP and MTF2 motors are UL recognized, it is the responsibility of the user to insure that the installation complies with the conditions of acceptability as specified in the UR file.

Installation intended to meet the cCSA_{US} requirements must follow the instructions provided in the “Wiring Notes” as a minimum standard. Follow all local codes that exceed cCSA_{US} requirements. Refer to the technical data on the motor nameplate for electrical and performance data.

MOTOR DIMENSIONS

(DIMENSIONS = INCHES)

MTF2 T-FRAME SINGLE-PHASE FARM-DUTY MOTOR DIMENSIONS

PART NUMBER	DIM. C	U	R	S	ES
MTF2-002-1B18-182	18.6	1.125	0.986	0.25	1.78
MTF2-003-1B18	18.6	1.125	0.986	0.25	1.78
MTF2-005-1B18	18.6	1.125	0.986	0.25	1.78
MTF2-7P5-1B18-215	20.46	1.375	1.201	0.312	2.41
MTF2-010-1B18	20.46	1.375	1.201	0.312	2.41

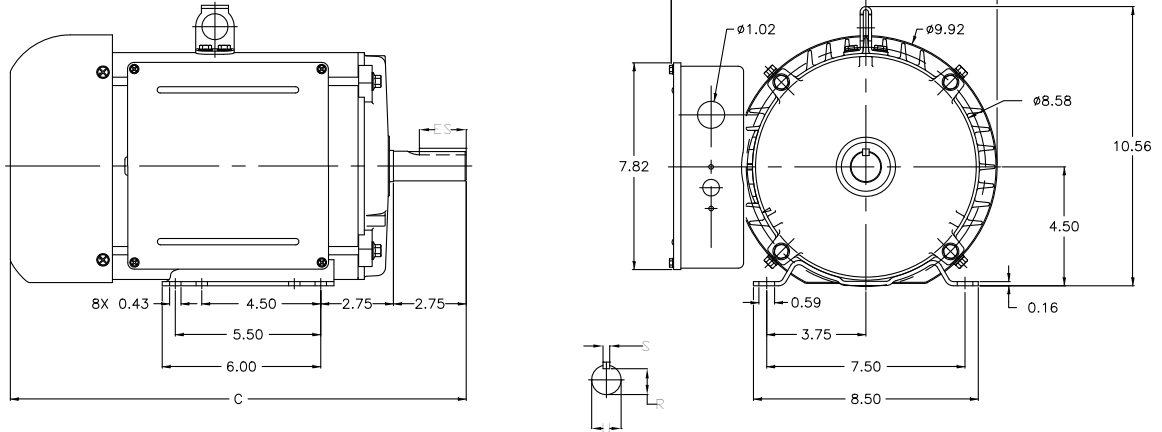

MTR2 56(H)C-FRAME SINGLE-PHASE ROLLED-STEEL MOTOR DIMENSIONS

MTR2 56C-FRAME SINGLE-PHASE MOTOR DIMENSIONS, 1/3 – 1 HP

PART NUMBER	DIM. C	PART NUMBER	DIM. C
MTR2-P33-1AB18	11.90	MTR2-P75-1AB18	12.40
MTR2-P33-1AB36	11.90	MTR2-P75-1AB36	11.90
MTR2-P50-1AB18	11.90	MTR2-001-1AB18	12.90
MTR2-P50-1AB36	11.90	MTR2-001-1AB36	12.40

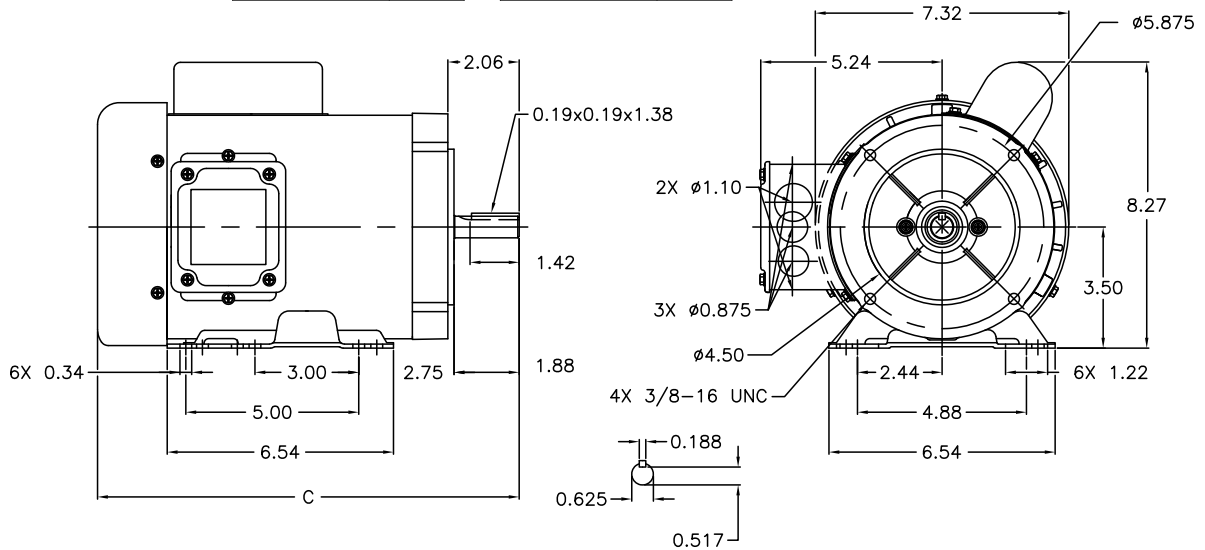

MTR2 56(H)C-FRAME SINGLE-PHASE ROLLED-STEEL MOTOR DIMENSIONS (CONTINUED)

(DIMENSIONS = INCHES)

MTR2 56(H)C-FRAME SINGLE-PHASE MOTOR DIMENSIONS, 1-1/2 – 2 HP

PART NUMBER	DIM. C
MTR2-1P5-1AB18	12.90
MTR2-002-1AB18	13.90
MTR2-1P5-1AB36	12.40
MTR2-002-1AB36	12.90

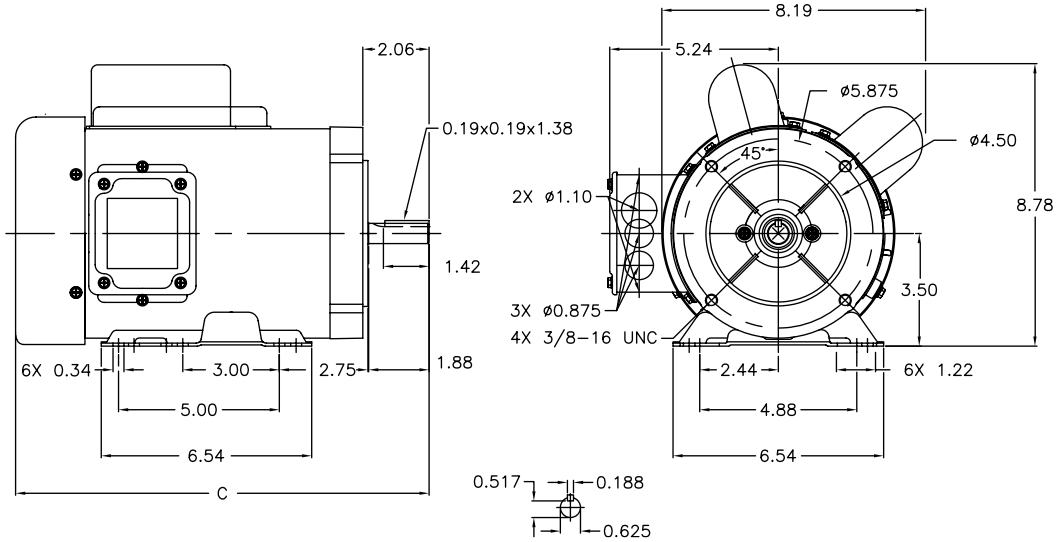

MTR2 56C-FRAME THREE-PHASE ROLLED-STEEL MOTOR DIMENSIONS

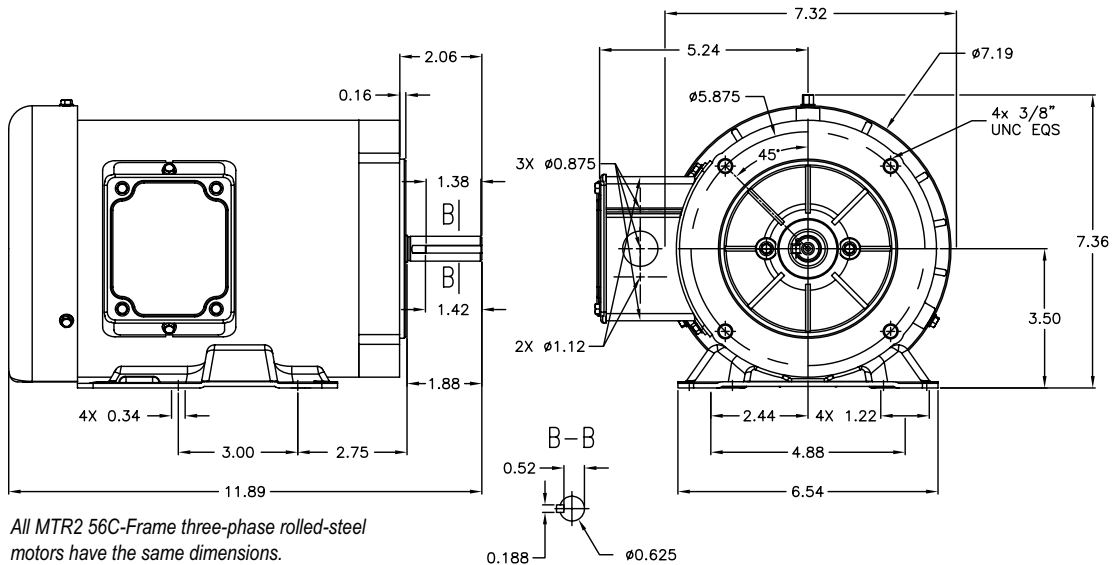

All MTR2 56C-Frame three-phase rolled-steel motors have the same dimensions.

MOTOR DIMENSIONS (CONTINUED)

(DIMENSIONS = INCHES)

MTRP 56HC-FRAME THREE-PHASE ROLLED-STEEL MOTOR DIMENSIONS

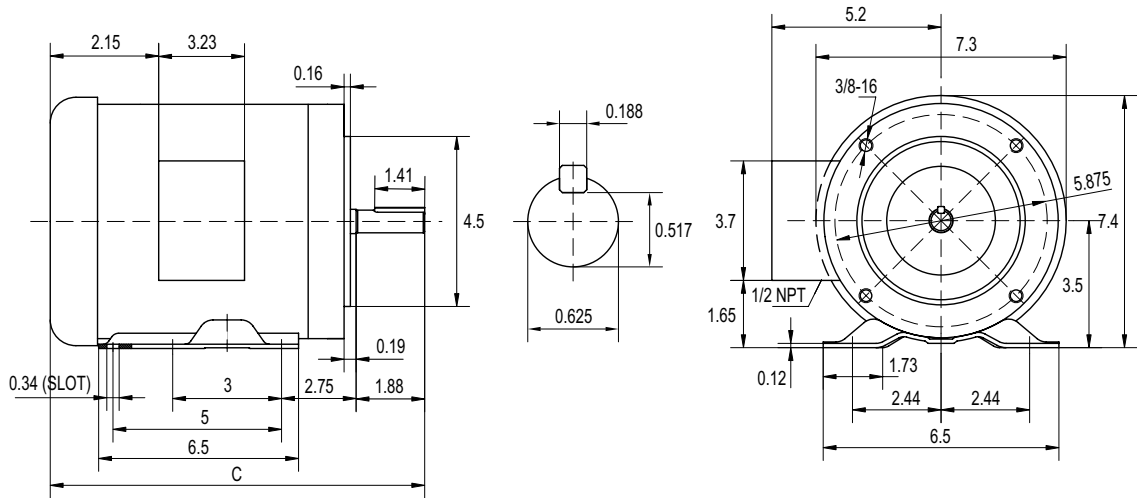

- C = 12.4 in; 1.0hp MTRP-001-3BD18
- C = 13.4 in; 1.5hp MTRP-1P5-3BD18
- C = 13.9 in; 2hp MTRP-002-3BD18
- C = 11.9 in; 1 to 2 hp MTRP-xxx-3BD36
- C = 12.9 in; 3hp MTRP-003-3BD36

UNITS = INCHES

MTRP-xxx-3BDxx IronHorse Motors
(3-phase rolled steel)

MTDP OPEN DRIP-PROOF THREE-PHASE ROLLED-STEEL MOTOR DIMENSIONS

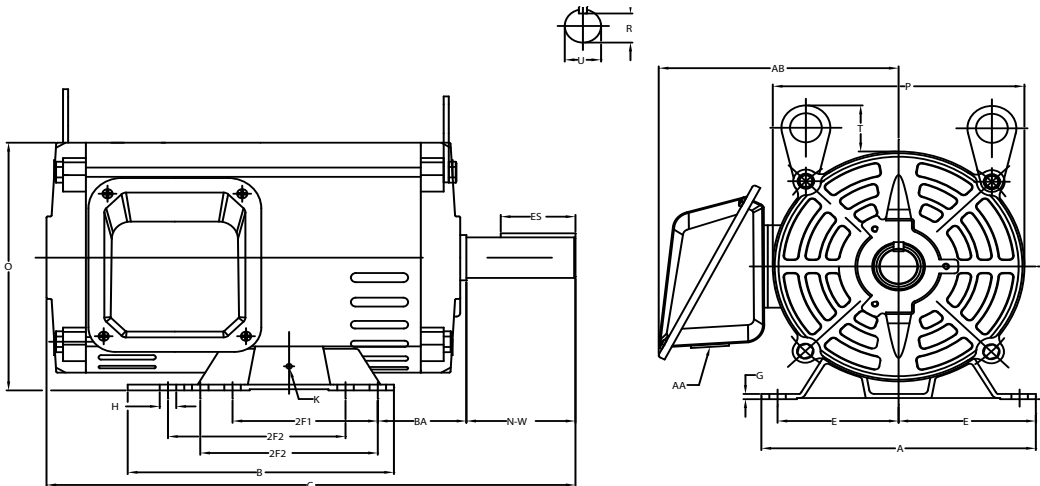

PART #	FRAME #	"E"	"2F1"	"2F2"	"H"	"BA"	"A"	"B"	"C"	"D"	"G"	"K"
MTDP-001-3BD18	143T	2.75	4.00	5.00	0.34	2.25	6.50	6.50	11.97	3.50	0.12	M5
MTDP-1P5-3BD18	145T	2.75	4.00	5.00	0.34	2.25	6.50	6.50	11.97	3.50	0.12	M5
MTDP-002-3BD18	145T	2.75	4.00	5.00	0.34	2.25	6.50	6.50	11.97	3.50	0.12	M5
MTDP-003-3BD36	145T	2.75	4.00	5.00	0.34	2.25	6.50	6.50	11.97	3.50	0.12	M5
MTDP-003-3BD18	182T	3.75	4.50	5.50	0.41	2.75	8.50	6.50	16.40	4.50	0.41	M5
MTDP-005-3BD36	182T	3.75	4.50	5.50	0.41	2.75	8.50	6.50	16.40	4.50	0.41	M5
MTDP-005-3BD18	184T	3.75	4.50	5.50	0.41	2.75	8.50	6.50	16.40	4.50	0.41	M5
MTDP-7P5-3BD36	184T	3.75	4.50	5.50	0.41	2.75	8.50	6.50	16.40	4.50	0.41	M5
MTDP-7P5-3BD18	213T	4.25	5.50	7.00	0.43	3.50	9.69	8.18	17.80	5.25	0.18	M5
MTDP-010-3BD18	215T	4.25	5.50	7.00	0.43	3.50	9.69	8.18	17.80	5.25	0.18	M5
MTDP-015-3BD18	254T	5.00	8.25	10.00	0.53	4.25	12.05	11.57	22.30	6.25	0.24	M6
MTDP-020-3BD18	256T	5.00	8.25	10.00	0.53	4.25	12.05	11.57	22.30	6.25	0.24	M6
MTDP-025-3BD18	284T	5.50	9.50	11.00	0.53	4.75	12.80	12.80	25.00	7.00	0.24	M6
MTDP-030-3BD18	286T	5.50	9.50	11.00	0.53	4.75	12.80	12.80	25.00	7.00	0.24	M6
MTDP-040-3BD18	324T	6.25	10.50	12.00	0.66	5.25	15.08	14.00	27.80	8.00	0.28	M8
MTDP-050-3BD18	326T	6.25	10.50	12.00	0.66	5.25	15.08	14.00	27.80	8.00	0.28	M8
PART #	FRAME #	"R"	"ES"	"S"	"U"	"N-W"	"P"	"AB"	"AA"	"O"	"T"	
MTDP-001-3BD18	143T	0.771	1.41	0.188	0.875	2.25	6.40	5.38	1.09	6.70	--	
MTDP-1P5-3BD18	145T	0.771	1.41	0.188	0.875	2.25	6.40	5.38	1.09	6.70	--	
MTDP-002-3BD18	145T	0.771	1.41	0.188	0.875	2.25	6.40	5.38	1.09	6.70	--	
MTDP-003-3BD36	145T	0.771	1.41	0.188	0.875	2.25	6.40	5.38	1.09	6.70	--	
MTDP-003-3BD18	182T	0.986	1.78	0.250	1.125	2.75	7.72	7.55	1.09	8.40	1.60	
MTDP-005-3BD36	182T	0.986	1.78	0.250	1.125	2.75	7.72	7.55	1.09	8.40	1.60	
MTDP-005-3BD18	184T	0.986	1.78	0.250	1.125	2.75	7.72	7.55	1.09	8.40	1.60	
MTDP-7P5-3BD36	184T	0.986	1.78	0.250	1.125	2.75	7.72	7.55	1.09	8.40	1.60	
MTDP-7P5-3BD18	213T	1.201	2.41	0.312	1.375	3.38	8.98	8.16	1.38	9.74	1.50	
MTDP-010-3BD18	215T	1.201	2.41	0.312	1.375	3.38	8.98	8.16	1.38	9.74	1.50	
MTDP-015-3BD18	254T	1.416	2.91	0.375	1.625	4.00	10.63	9.70	1.38	11.60	2.48	
MTDP-020-3BD18	256T	1.416	2.91	0.375	1.625	4.00	10.63	9.70	1.38	11.60	2.36	
MTDP-025-3BD18	284T	1.591	3.28	0.500	1.875	4.62	12.20	11.10	2.00	13.10	2.36	
MTDP-030-3BD18	286T	1.591	3.28	0.500	1.875	4.62	12.20	11.10	2.00	13.10	2.36	
MTDP-040-3BD18	324T	1.845	3.88	0.500	2.125	5.25	14.00	13.10	2.50	15.00	2.36	
MTDP-050-3BD18	326T	1.845	3.88	0.500	2.125	5.25	14.00	13.10	2.50	15.00	2.36	

MOTOR DIMENSIONS (CONTINUED)

(DIMENSIONS = INCHES)

MTCP2 PREMIUM-EFFICIENCY T-FRAME THREE-PHASE MOTOR DIMENSIONS

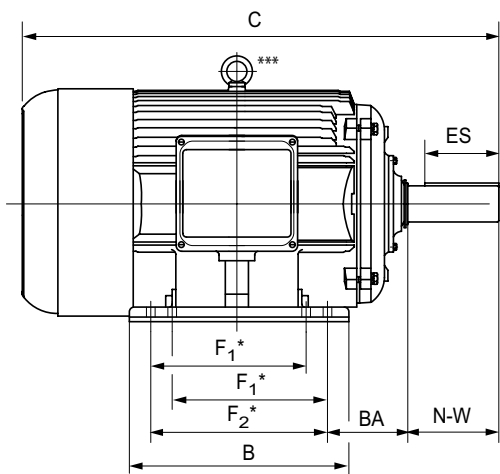

* Various frame sizes have 2 or 4 mounting holes per mounting foot (one mounting foot per side).

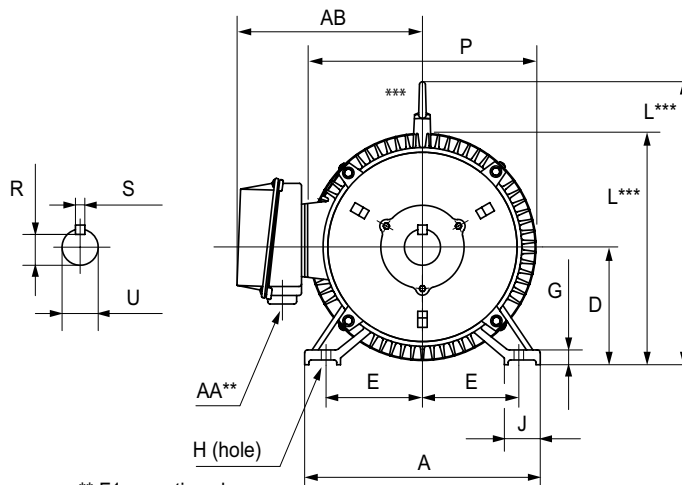

** F1 mounting shown.
 ** Some frame sizes are F1/F2 convertible.
 *** Frames 143T & 145T have no lifting eyelet.

Dimensions [inches, except as noted] Premium-Efficiency Three-Phase T-Frame Motors – 1800 rpm											
Part Number	HP	NEMA Frame	A	AA**	AB	B	BA	C	D	E	ES
MTCP2-001-3BD18	1	143T	7	3/4" NPT	6.7	5.6	2.25	12.47	3.5	2.75	1.41
MTCP2-1P5-3BD18	1-1/2	145T	7	3/4" NPT	6.7	6.6	2.25	13.47	3.5	2.75	1.41
MTCP2-002-3BD18	2		7	3/4" NPT	6.7	6.6	2.25	13.47	3.5	2.75	1.41
MTCP2-003-3BD18	3	182T	9	1" NPT	7.2	6	2.75	15	4.5	3.75	1.78
MTCP2-005-3BD18	5	184T	9	1" NPT	8.2	7	2.75	16	4.5	3.75	1.78
MTCP2-7P5-3BD18	7-1/2	213T	10.5	1" NPT	8.5	7.5	3.5	19.5	5.25	4.25	2.41
MTCP2-010-3BD18	10	215T	10.5	1" NPT	8.5	9	3.5	21	5.25	4.25	2.41
MTCP2-015-3BD18	15	254T	12.5	1.5" NPT	10.5	10.3	4.25	23.3	6.25	5	2.91
MTCP2-020-3BD18	20	256T	12.5	1.5" NPT	10.5	12	4.25	25.3	6.25	5	2.91
MTCP2-025-3BD18	25	284T	14	1.5" NPT	11.5	12.4	4.75	26.63	7	5.5	3.28
MTCP2-030-3BD18	30	286T	14	1.5" NPT	11.5	13.9	4.75	28.1	7	5.5	3.28
MTCP2-040-3BD18	40	324T	16	2" NPT	14.5	13.5	5.25	29.6	8	6.25	3.91
MTCP2-050-3BD18	50	326T	16	2" NPT	14.5	15	5.25	31.2	8	6.25	3.91
MTCP2-060-3BD18	60	364T	17	3" NPT	16.5	15	5.88	32.58	9	7	4.28
MTCP2-075-3BD18	75	365T	17	3" NPT	16.5	16	5.88	33.6	9	7	4.28
MTCP2-100-3BD18	100	405T	20	3" NPT	19	17	6.62	38.1	10	8	5.65
MTCP2-125-3BD18	125	444T	22	2x3" NPT	20	18.5	7.5	41.9	11	9	6.91
MTCP2-150-3BD18	150	445T	22	2x3" NPT	20	20.5	7.5	44	11	9	6.91
MTCP2-200-3BD18	200	445/7T	22	2x3" NPT	20	24	7.5	47.4	11	9	6.91
MTCP2-250-3D18	250	449T	22	2x3" NPT	19.5	31	7.5	58	11	9	6.91
MTCP2-300-3D18	300	449T	22	2x3" NPT	19.5	31	7.5	58	11	9	6.91

* Various frame sizes have 2 or 4 mounting holes per mounting foot.
 ** AA dimension is conduit fitting size. F1 mounting shown; some frame sizes are F1/F2 convertible; refer to T-frame "Motor Specifications" table.
 (F2 mounting = conduit entrance on right side facing shaft.)
 *** Frame sizes 143T(C) and 145T(C) have no lifting eyelet.

**** TABLE CONTINUED NEXT PAGE (for dimensions F1-U) ****

MTCP2 PREMIUM-EFFICIENCY T-FRAME THREE-PHASE MOTOR DIMENSIONS (CONTINUED)

(DIMENSIONS = INCHES)

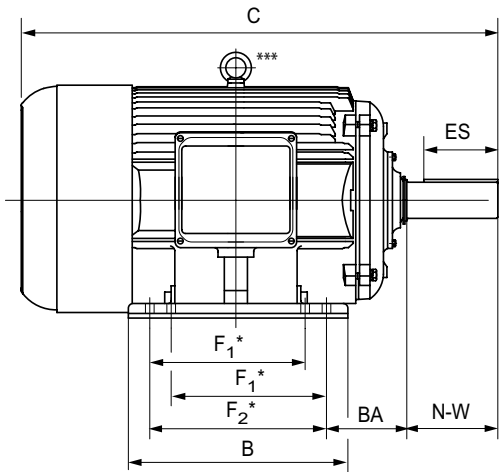

* Various frame sizes have 2 or 4 mounting holes per mounting foot (one mounting foot per side).

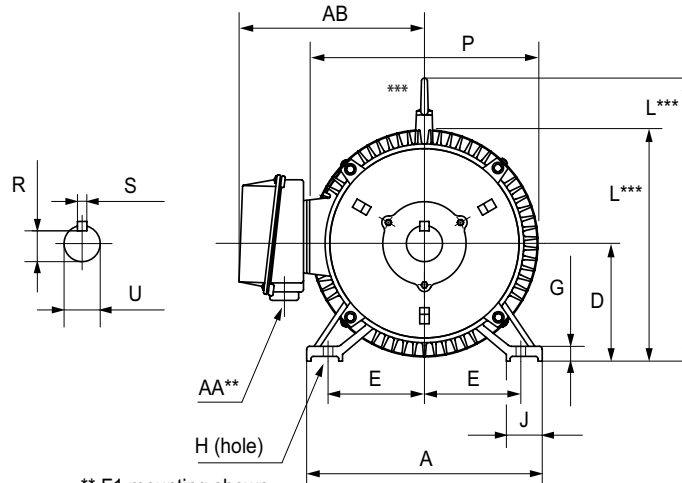

** F1 mounting shown.
 ** Some frame sizes are F1/F2 convertible.
 *** Frames 143T & 145T have no lifting eyelet.

**** TABLE CONTINUED FROM PREVIOUS PAGE (for dimensions A-ES) ****

Dimensions [inches, except as noted]													
Premium-Efficiency Three-Phase T-Frame Motors – 1800 rpm													
Part Number	HP	Frame	F ₁ *	F ₂ *	G	H	J	N-W	L	P	R	S	U
MTCP2-001-3BD18	1	143T	n/a	4	0.47	0.34	1.45	2.25	7.6	7.8	0.771	0.188	0.8759
MTCP2-1P5-3BD18	1-1/2	145T	4	5	0.47	0.34	1.45	2.25	7.8	8	0.771	0.188	0.8759
MTCP2-002-3BD18	2		4	5	0.43	0.34	1	2.25	7.8	8	0.771	0.188	0.8759
MTCP2-003-3BD18	3	182T	n/a	4.5	0.6	0.41	2	2.75	9.5	9.7	0.986	0.25	1.125
MTCP2-005-3BD18	5	184T	4.5	5.5	0.6	0.41	2	2.75	9.5	9.7	0.986	0.25	1.125
MTCP2-7P5-3BD18	7-1/2	213T	n/a	5.5	0.71	0.41	2.4	3.38	10.6	10.6	1.201	0.312	1.375
MTCP2-010-3BD18	10	215T	5.5	7	0.71	0.41	2.4	3.38	10.6	10.4	1.201	0.312	1.375
MTCP2-015-3BD18	15	254T	n/a	8.25	0.79	0.53	2.40	4	12.9	12.6	1.416	0.375	1.625
MTCP2-020-3BD18	20	256T	8.25	10	0.79	0.53	2.40	4	12.9	12.6	1.416	0.375	1.625
MTCP2-025-3BD18	25	284T	n/a	9.5	0.87	0.53	2.8	4.62	14.3	14	1.591	0.5	1.875
MTCP2-030-3BD18	30	286T	9.5	11	0.87	0.53	2.8	4.62	14.3	14	1.591	0.5	1.875
MTCP2-040-3BD18	40	324T	n/a	10.5	0.99	0.66	2.8	5.25	16	15.7	1.845	0.5	2.125
MTCP2-050-3BD18	50	326T	10.5	12	0.99	0.66	2.8	5.25	16	15.7	1.845	0.5	2.125
MTCP2-060-3BD18	60	364T	n/a	11.25	1.18	0.66	3	5.88	18.8	19.1	2.021	0.625	2.375
MTCP2-075-3BD18	75	365T	11.25	12.25	1.18	0.66	3	5.88	18.8	19.1	2.021	0.625	2.375
MTCP2-100-3BD18	100	405T	12.25	13.75	1.18	0.81	3.2	7.25	21.1	21.6	2.45	0.75	2.875
MTCP2-125-3BD18	125	444T	n/a	14.5	1.38	0.81	3.35	8.5	23	23.5	2.88	0.875	3.375
MTCP2-150-3BD18	150	445T	14.5	16.5	1.38	0.81	3.35	8.5	23	23.5	2.88	0.875	3.375
MTCP2-200-3BD18	200	445/7T	16.5	20	1.38	0.81	3.35	8.5	23	23.5	2.88	0.875	3.375
MTCP2-250-3D18	250	449T	n/a	25	1.58	0.81	3.4	8.500	23	24	2.88	0.875	3.375
MTCP2-300-3D18	300	449T	n/a	25	1.58	0.81	3.4	8.500	23	24	2.88	0.875	3.375

* Various frame sizes have 2 or 4 mounting holes per mounting foot.
 ** AA dimension is conduit fitting size. F1 mounting shown; some frame sizes are F1/F2 convertible; refer to T-frame "Motor Specifications" table.
 (F2 mounting = conduit entrance on right side facing shaft.)
 *** Frame sizes 143T(C) and 145T(C) have no lifting eyelet.

MTCP2 PREMIUM-EFFICIENCY T-FRAME THREE-PHASE MOTOR DIMENSIONS (CONTINUED)

(DIMENSIONS = INCHES)

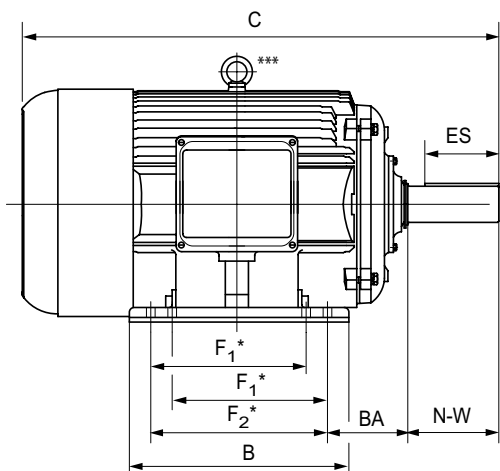

* Various frame sizes have 2 or 4 mounting holes per mounting foot (one mounting foot per side).

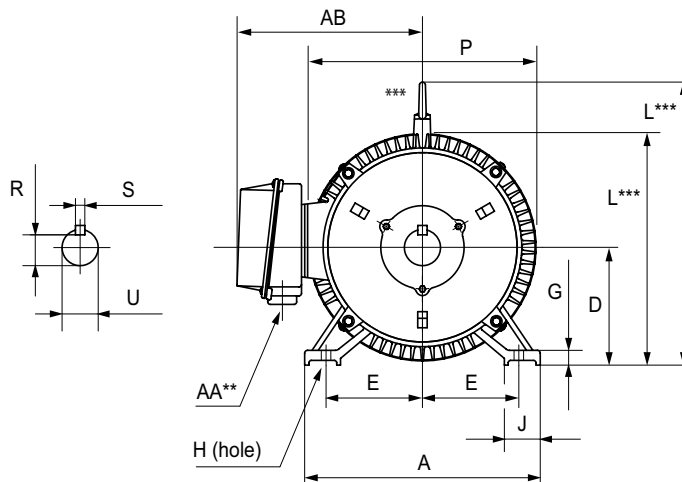

** F1 mounting shown.
 ** Some frame sizes are F1/F2 convertible.
 *** Frames 143T & 145T have no lifting eyelet.

Dimensions [inches, except as noted]											
Premium-Efficiency Three-Phase T-Frame Motors – 1200 & 3600 rpm											
Part Number	HP	NEMA Frame	A	AA**	AB	B	BA	C	D	E	ES
1200 rpm Motors											
MTCP2-001-3BD12	1	145T	7	3/4" NPT	6.7	6.6	2.25	13.47	3.5	2.75	1.41
MTCP2-1P5-3BD12	1-1/2	182T	9	1" NPT	7.2	6	2.75	15	4.5	3.75	1.78
MTCP2-002-3BD12	2	184T	9	1" NPT	8.2	7	2.75	16	4.5	3.75	1.78
MTCP2-003-3BD12	3	213T	10.5	1" NPT	8.5	7.5	3.5	19.5	5.25	4.25	2.41
MTCP2-005-3BD12	5	215T	10.5	1" NPT	8.5	9	3.5	21	5.25	4.25	2.41
MTCP2-7P5-3BD12	7-1/2	254T	12.5	1.5" NPT	10.5	10.3	4.25	23.3	6.25	5	2.91
MTCP2-010-3BD12	10	256T	12.5	1.5" NPT	10.5	12	4.25	25.3	6.25	5	2.91
MTCP2-015-3BD12	15	284T	14	1.5" NPT	11.5	12.4	4.75	26.63	7	5.5	3.28
MTCP2-020-3BD12	20	286T	14	1.5" NPT	11.5	13.9	4.75	28.1	7	5.5	3.28
3600 rpm Motors											
MTCP2-1P5-3BD36	1-1/2	143T	7	3/4" NPT	6.7	5.6	2.25	12.47	3.5	2.75	1.41
MTCP2-002-3BD36	2	145T	7	3/4" NPT	6.7	6.6	2.25	13.47	3.5	2.75	1.41
MTCP2-003-3BD36	3	182T	9	1" NPT	7.2	6	2.75	15	4.5	3.75	1.78
MTCP2-005-3BD36	5	184T	9	1" NPT	8.2	7	2.75	16	4.5	3.75	1.78
MTCP2-7P5-3BD36	7-1/2	213T	10.5	1" NPT	8.5	7.5	3.5	19.5	5.25	4.25	2.41
MTCP2-010-3BD36	10	215T	10.5	1" NPT	8.5	9	3.5	21	5.25	4.25	2.41
MTCP2-015-3BD36	15	254T	12.5	1.5" NPT	10.5	10.3	4.25	23.3	6.25	5	2.91
MTCP2-020-3BD36	20	256T	12.5	1.5" NPT	10.5	12	4.25	25.3	6.25	5	2.91
* Various frame sizes have 2 or 4 mounting holes per mounting foot.											
** AA dimension is conduit fitting size. F1 mounting shown; some frame sizes are F1/F2 convertible; refer to T-frame "Motor Specifications" table. (F2 mounting = conduit entrance on right side facing shaft.)											
*** Frame sizes 143T(C) and 145T(C) have no lifting eyelet.											
**** TABLE CONTINUED NEXT PAGE (for dimensions F1-U) ****											

MTCP2 PREMIUM-EFFICIENCY T-FRAME THREE-PHASE MOTOR DIMENSIONS (CONTINUED)

(DIMENSIONS = INCHES)

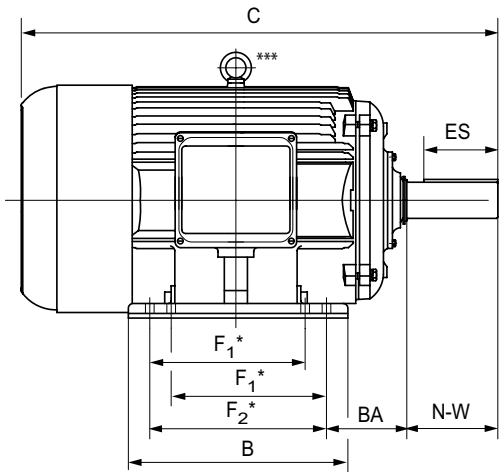

* Various frame sizes have 2 or 4 mounting holes per mounting foot (one mounting foot per side).

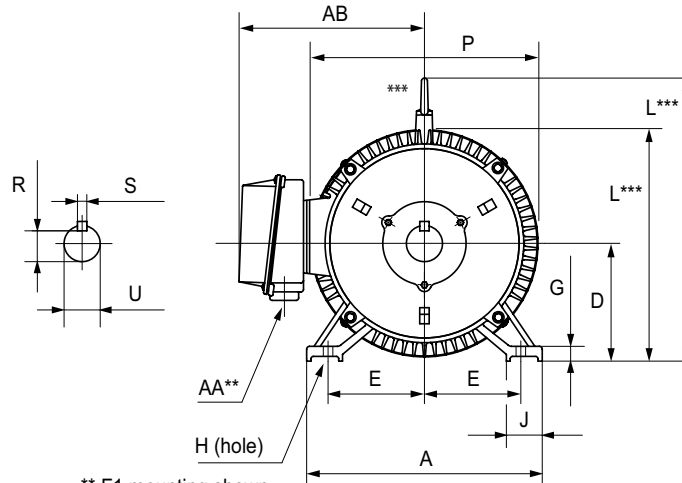

** F1 mounting shown.
 ** Some frame sizes are F1/F2 convertible.
 *** Frames 143T & 145T have no lifting eyelet.

**** TABLE CONTINUED FROM PREVIOUS PAGE (for dimensions A-ES) ****

Dimensions [inches, except as noted]

Premium-Efficiency Three-Phase T-Frame Motors – 1200 & 3600 rpm

Part Number	HP	Frame	F ₁ *	F ₂ *	G	H	J	N-W	L	P	R	S	U
1200 rpm Motors													
MTCP2-001-3BD12	1	145T	4	5	0.43	0.34	1	2.25	7.8	8	0.771	0.188	0.8759
MTCP2-1P5-3BD12	1-1/2	182T	n/a	4.5	0.6	0.41	2	2.75	9.5	9.7	0.986	0.25	1.125
MTCP2-002-3BD12	2	184T	4.5	5.5	0.6	0.41	2	2.75	9.5	9.7	0.986	0.25	1.125
MTCP2-003-3BD12	3	213T	n/a	5.5	0.71	0.41	2.4	3.38	10.6	10.6	1.201	0.312	1.375
MTCP2-005-3BD12	5	215T	5.5	7	0.71	0.41	2.4	3.38	10.6	10.4	1.201	0.312	1.375
MTCP2-7P5-3BD12	7-1/2	254T	n/a	8.25	0.79	0.53	2.40	4	12.9	12.6	1.416	0.375	1.625
MTCP2-010-3BD12	10	256T	8.25	10	0.79	0.53	2.40	4	12.9	12.6	1.416	0.375	1.625
MTCP2-015-3BD12	15	284T	n/a	9.5	0.87	0.53	2.8	4.62	14.3	14	1.591	0.5	1.875
MTCP2-020-3BD12	20	286T	9.5	11	0.87	0.53	2.8	4.62	14.3	14	1.591	0.5	1.875
3600 rpm Motors													
MTCP2-1P5-3BD36	1-1/2	143T	n/a	4	0.47	0.34	1	2.25	7.6	7.8	0.771	0.188	0.8759
MTCP2-002-3BD36	2	145T	4	5	0.43	0.34	1	2.25	7.8	8	0.771	0.188	0.8759
MTCP2-003-3BD36	3	182T	n/a	4.5	0.6	0.41	2	2.75	9.5	9.7	0.986	0.25	1.125
MTCP2-005-3BD36	5	184T	4.5	5.5	0.6	0.41	2	2.75	9.5	9.7	0.986	0.25	1.125
MTCP2-7P5-3BD36	7-1/2	213T	n/a	5.5	0.71	0.41	2.4	3.38	10.6	10.6	1.201	0.312	1.375
MTCP2-010-3BD36	10	215T	5.5	7	0.71	0.41	2.4	3.38	10.6	10.4	1.201	0.312	1.375
MTCP2-015-3BD36	15	254T	n/a	8.25	0.79	0.53	2.40	4	12.9	12.6	1.416	0.375	1.625
MTCP2-020-3BD36	20	256T	8.25	10	0.79	0.53	2.40	4	12.9	12.6	1.416	0.375	1.625

* Various frame sizes have 2 or 4 mounting holes per mounting foot.

** AA dimension is conduit fitting size. F1 mounting shown; some frame sizes are F1/F2 convertible; refer to T-frame "Motor Specifications" table.
 (F2 mounting = conduit entrance on right side facing shaft.)

*** Frame sizes 143T(C) and 145T(C) have no lifting eyelet.

MTCP2 PREMIUM-EFFICIENCY TC-FRAME THREE-PHASE MOTOR DIMENSIONS

(DIMENSIONS = INCHES)

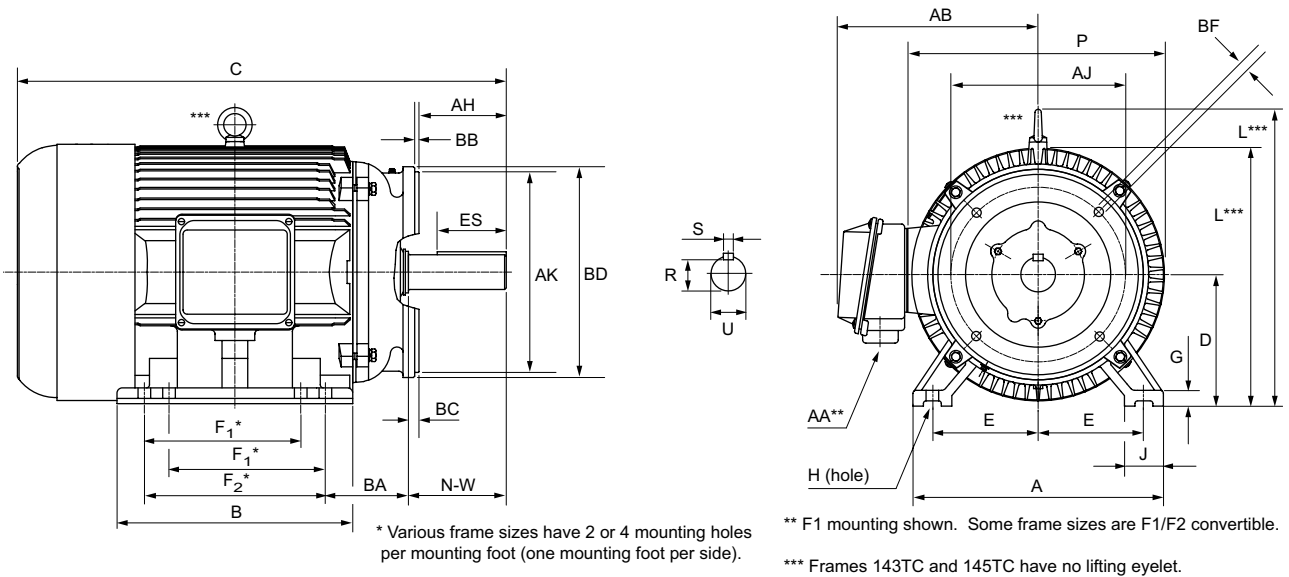

Dimensions [inches, except as noted] Premium-Efficiency Three-Phase TC-Frame Motors – 1800 rpm															
Part # MTCP2- xxx- 3BD18C	HP	NEMA Frame	A	AA**	AB	AH	AJ	AK	B	BA	BB	BC	BD	BF	C
-001-	1	143TC	7	3/4"NPT	6.7	1.96	5.875	4.5	5.6	2.25	0.16	0.29	6.5	3/8-16	12.5
-1P5-	1-1/2	145TC	7	3/4"NPT	6.7	1.96	5.875	4.5	6.6	2.25	0.16	0.29	6.5	3/8-16	13.5
-002-	2		7		6.6										
-003-	3	182TC	9	1" NPT	7.2	2.37	7.25	8.5	6	2.75	0.25	0.38	9	1/2-13	15
-005-	5	184TC	9	1" NPT	8.2	2.37	7.25	8.5	7	2.75	0.25	0.38	9	1/2-13	16
-7P5-	7-1/2	213TC	10.5	1" NPT	8.5	2.87	7.25	8.5	7.5	3.5	0.25	0.51	9	1/2-13	20.3
-010-	10	215TC	10.5	1" NPT	8.5	2.87	7.25	8.5	9	3.5	0.25	0.51	9	1/2-13	21.8
-015-	15	254TC	12.5	1.5"NPT	10.5	3.75	7.25	8.5	10.3	4.25	0.25	0.25	10	1/2-13	23.3
-020-	20	256TC	12.5	1.5"NPT	10.5	3.75	7.25	8.5	12	4.25	0.25	0.25	10	1/2-13	25.3
-025-	25	284TC	14	1.5"NPT	11.5	4.38	9	10.5	12.4	4.75	0.25	0.25	11.25	1/2-13	26.6
-030-	30	286TC	14	1.5"NPT	11.5	4.38	9	10.5	13.9	4.75	0.25	0.24	11.25	1/2-13	28.1

* Various frame sizes have 2 or 4 mounting holes per mounting foot.

** AA dimension is conduit fitting size. F1 mounting shown; some frame sizes are F1/F2 convertible; refer to T-frame "Motor Specifications" table.
(F2 mounting = conduit entrance on right side facing shaft.)

*** Frame sizes 143T(C) and 145T(C) have no lifting eyelet.

**** TABLE CONTINUED NEXT PAGE (for dimensions D-U) ****

MTCP2 PREMIUM-EFFICIENCY TC-FRAME THREE-PHASE MOTOR DIMENSIONS (CONTINUED)

(DIMENSIONS = INCHES)

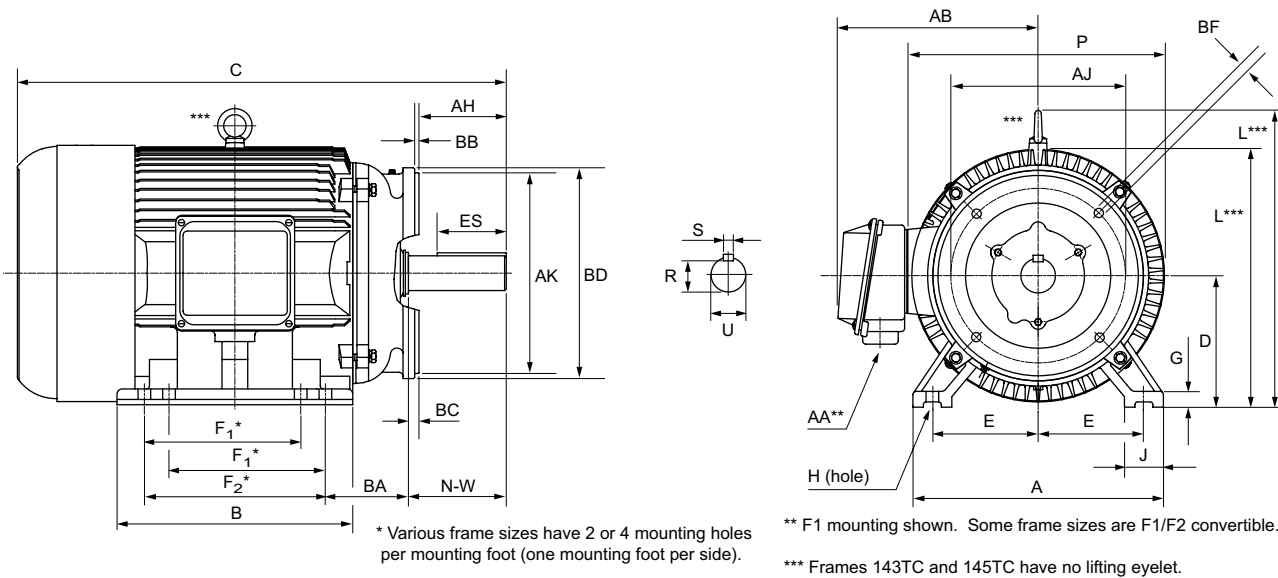

**** TABLE CONTINUED FROM PREVIOUS PAGE (for dimensions A-C) ****

Dimensions [inches, except as noted]
Premium-Efficiency Three-Phase TC-Frame Motors – 1800 rpm

Part # MTCP2- xxx- 3BD18C	HP	NEMA Frame	D	E	ES	F1*	F2*	G	H	J	N-W	L	P	R	S	U
-001-	1	143TC	3.5	2.75	1.41	n/a	4	0.47	0.34	1	2.25	7.6	7.8	0.771	0.188	0.8759
-1P5-	1-1/2	145TC	3.5	2.75	1.41	4	5	0.43	0.34	1.2	2.25	7.8	8	0.771	0.188	0.8759
-002-	2				1.41			0.43		1.2		7.8	8	0.771	0.188	0.8759
-003-	3	182TC	4.5	3.75	1.78	n/a	4.5	0.6	0.41	2	2.75	9.5	9.7	0.986	0.25	1.125
-005-	5	184TC	4.5	3.75	1.78	4.5	5.5	0.6	0.41	2	2.75	9.5	9.7	0.986	0.25	1.125
-7P5-	7-1/2	213TC	5.25	4.25	2.41	n/a	5.5	0.71	0.41	2.4	3.38	10.6	10.4	1.201	0.312	1.375
-010-	10	215TC	5.25	4.25	2.41	5.5	7	0.71	0.41	2.4	3.38	10.6	10.4	1.201	0.312	1.375
-015-	15	254TC	6.25	5	2.91	n/a	8.25	0.79	0.53	2.40	4	12.9	12.6	1.416	0.375	1.625
-020-	20	256TC	6.25	5	2.91	8.25	10	0.79	0.53	2.40	4	12.9	12.6	1.416	0.375	1.625
-025-	25	284TC	7	5.5	3.28	n/a	9.5	0.87	0.53	2.8	4.62	14.3	14	1.591	0.5	1.875
-030-	30	286TC	7	5.5	3.28	9.5	11	0.87	0.53	2.8	4.62	14.3	14	1.591	0.5	1.875

* Various frame sizes have 2 or 4 mounting holes per mounting foot.

** AA dimension is conduit fitting size. F1 mounting shown; some frame sizes are F1/F2 convertible; refer to T-frame "Motor Specifications" table.
(F2 mounting = conduit entrance on right side facing shaft.)

*** Frame sizes 143T(C) and 145T(C) have no lifting eyelet.

TERMINAL AND WIRING DIAGRAMS

IRONHORSE® SINGLE-PHASE MOTORS

MTR2 GENERAL-PURPOSE MOTORS

1/3 hp – 1.5hp 1Ø MTR2 models
6-Lead, 115/208-230 VAC

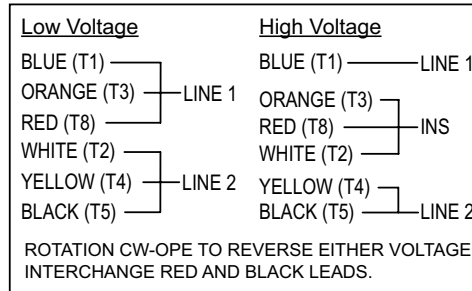

MTF2 FARM-DUTY MOTORS

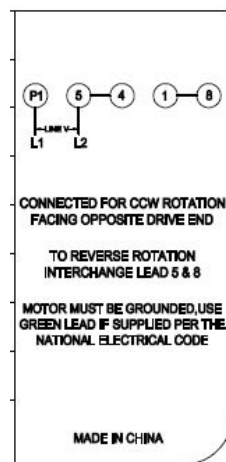

MTRJ JET PUMP MOTORS

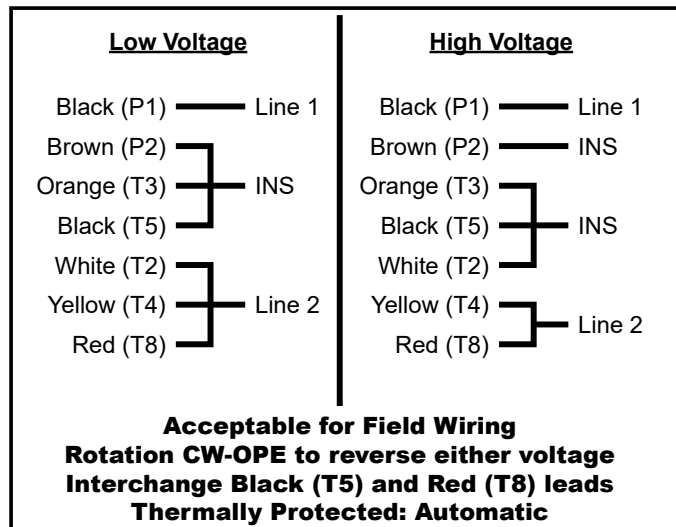

IRONHORSE® THREE-PHASE MOTORS

MTDP OPEN DRIP PROOF MOTORS

MTDP 1-50 hp 3Ø models

- T1 = Blue
- T2 = White
- T3 = Orange
- T4 = Yellow
- T5 = Black
- T6 = Purple
- T7 = Pink
- T8 = Red
- T9 = Grey

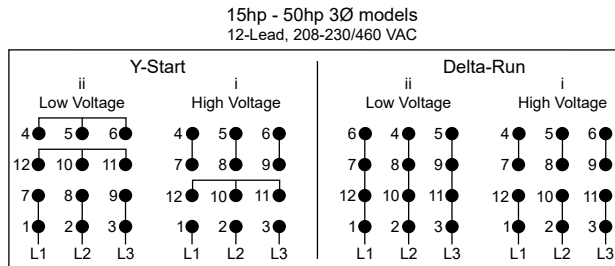
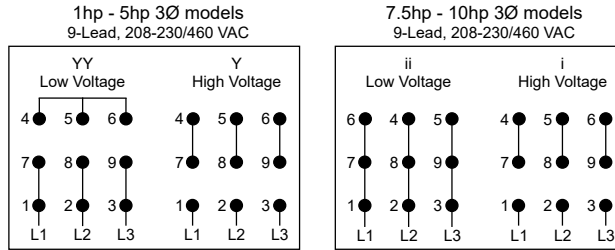

Nameplate / Wiring Diagram abbreviations:

- 1) "INS" = The wires are to be connected and then insulated.
- 2) "ODE" = Opposite Drive End.
- 3) "OPE" = Opposite Pulley End.

MTCP2 MOTORS

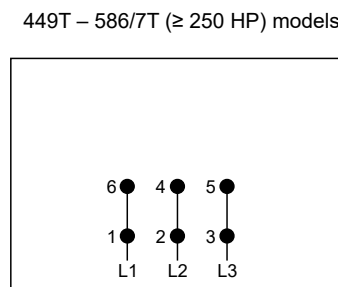
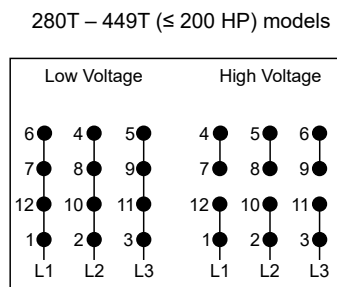
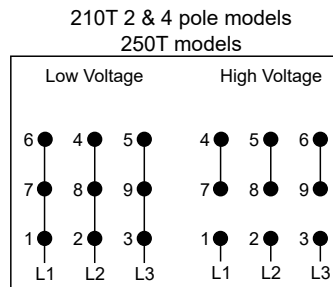
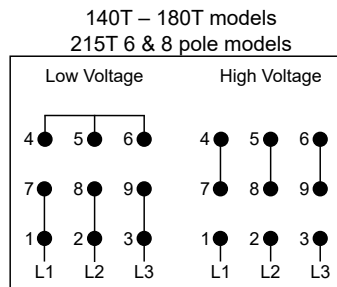

MTRJ JET PUMP MOTORS

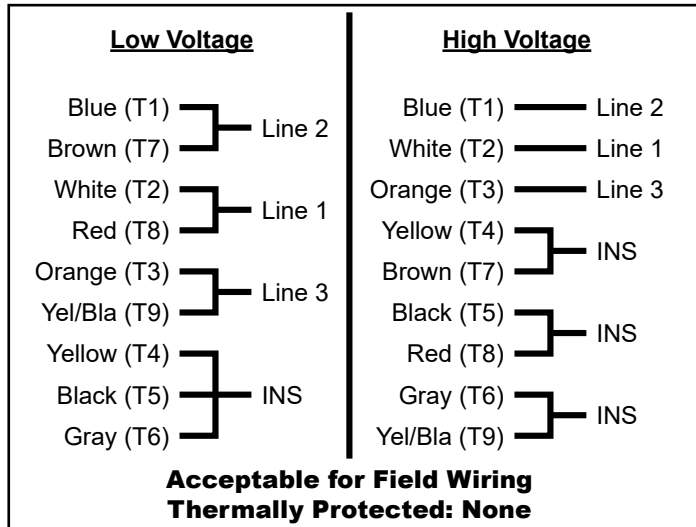

TERMINAL AND WIRING DIAGRAMS (CONTINUED)

SINGLE-PHASE MOTORS REVERSING DIAGRAMS

FOR 115VAC POWER CIRCUIT (115VAC CONTROL CIRCUIT)

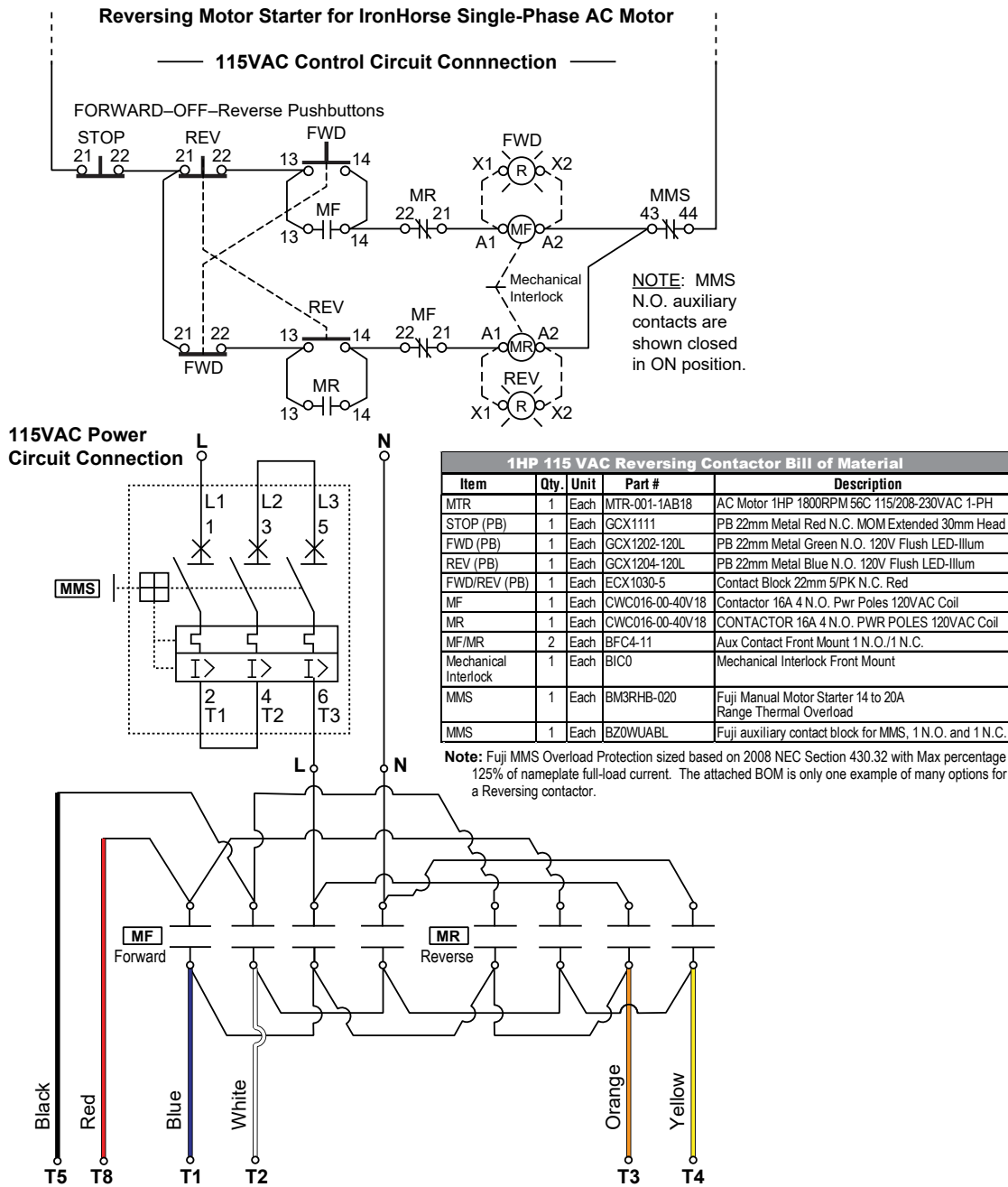

Note: To reverse motor direction the wiring of T5 Black and T8 Red should be swapped. Always check the motor manufacturer's wiring diagrams (or nameplate) for proper reversing of 1-phase motors.



WARNING: THIS WIRING DIAGRAM DOES NOT PREVENT PLUGGING OR INSTANT REVERSING OF THE MOTOR, WHICH IS VERY STRESSFUL TO THE MOTOR AND MAY TRIP ANY OVERCURRENT/OVERLOAD PROTECTION.

TERMINAL AND WIRING DIAGRAMS – SINGLE-PHASE MOTORS REVERSING DIAGRAMS (CONTINUED)

FOR 208-230VAC POWER CIRCUIT (115VAC CONTROL CIRCUIT)

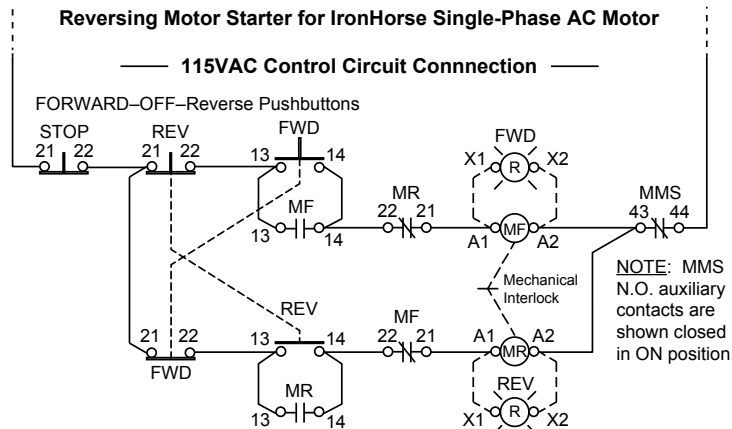

208-230VAC Power Circuit Connection

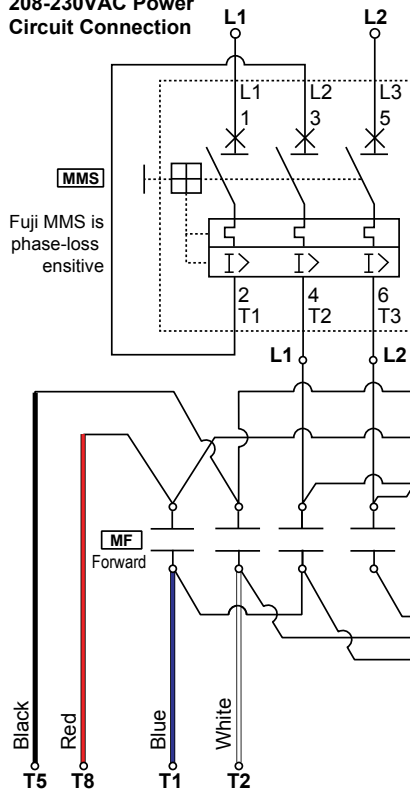

1HP 208 VAC Reversing Contactor Bill of Material				
Item	Qty.	Unit	Part #	Description
MTR	1	Each	MTR-001-1AB18	AC Motor 1HP 1800RPM 56C 115/208-230VAC 1-PH
STOP (PB)	1	Each	GCX1111	PB 22mm Metal Red N.C. MOM Extended 30mm Head
FWD (PB)	1	Each	GCX1202-120L	PB 22mm Metal Green N.O. 120V Flush LED-Illum
REV (PB)	1	Each	GCX1204-120L	PB 22mm Metal Blue N.O. 120V Flush LED-Illum
FWD/REV (PB)	1	Each	ECX1030-5	Contact Block 22mm 5/PK N.C. Red
MF	1	Each	CWC016-00-40V18	Contact 16A 4 N.O. Pwr Poles 120VAC Coil
MR	1	Each	CWC016-00-40V18	CONTACTOR 16A 4 N.O. PWR POLES 120VAC Coil
MF/MR	2	Each	BFC4-11	Aux Contact Front Mount 1 N.O./1 N.C.
Mechanical Interlock	1	Each	BIC0	Mechanical Interlock Front Mount
MMS	1	Each	BM3RHB-020	Fuji Manual Motor Starter 14 to 20A Range Thermal Overload
MMS	1	Each	BZ0WUABL	Fuji auxiliary contact block for MMS, 1 N.O. and 1 N.C.

Note: Fuji MMS Overload Protection sized based on 2008 NEC Section 430.32 with Max percentage 125% of nameplate full-load current. The attached BOM is only one example of many options for a Reversing contactor.



Note: In applications involving Direct coupling of the motor, drive end, bearing life, may be increased by replacing roller bearings with equivalent ball bearings. Consult your EASA authorized motor shop for details. Reminder: To maintain motor warranty, any motor work must be accomplished by your local EASA authorized shop.



Note: To reverse motor direction, the wiring of T5 Black and T8 Red should be swapped. Always check the motor manufacturer's wiring diagrams (or nameplate) for proper reversing of 1-phase motors.



WARNING: THIS WIRING DIAGRAM DOES NOT PREVENT PLUGGING OR INSTANT REVERSING OF THE MOTOR, WHICH IS VERY STRESSFUL TO THE MOTOR AND MAY TRIP ANY OVERCURRENT/OVERLOAD PROTECTION.

MOTOR MOUNTING

GENERAL MOUNTING INFORMATION

IronHorse® motors should be properly mounted to prevent premature motor and/or bearing failure. When necessary, use motor shims to level the motor at all mounting bolt holes. Use proper diameter bolts of the highest grade material available for the application. Use the chart below to select the correct size bolt for each frame size.

A mounted motor must operate vibration free. Each motor installation should be checked for potential vibration situations. On motors 100hp and up, we recommend that foundation studs be used to secure the motor or slide base. Base shims should also be used when necessary for level mounting.

Motor Mounting Bolt Sizes				
Frame Size	Bolt Diameter	Minimum Useable Thread Length (A)	Minimum Exposed Anchor Length (B)	
56				
143T	5/16 in	0.45 in	0.88 in	
145T				
182T				
184T	3/8 in	0.53 in	1.50 in	
213T				
215T				
254T			1.44 in	
256T	1/2 in	0.69 in	1.69 in	
284T				
286T				
324T			2.19 in	
326T	5/8 in	0.85 in	2.06 in	
364T				
365T				
404T			2.50 in	
405T	3/4 in	0.95 in	3.00 in	
444T				
445T				
447T				
449T				

MOTOR MOUNTING ORIENTATION

MTF MOTORS

MTF motors can be mounted *only* in a horizontal orientation.

MTF2, MTR2, MTRP AND MTDP MOTORS

MTF2, MTR2, MTRP and MTDP motors can be mounted in any horizontal or vertical orientation.

MTCP2 MOTORS

MTCP2 motors can be mounted in horizontal or vertical, shaft-down orientations.

PROPER INSTALLATION CONDITIONS

Care should be taken to make sure that an IronHorse® motor is mounted at least thirty inches from a wall or structure that would prevent proper ventilation of the motor. The installation area should be free of dust and smoke particles. Any air contaminate could inhibit proper operation of the motor fan.

If an IronHorse motor is to be installed in a high altitude or in a low temperature location, use the Altitude / Ambient Temperature Derating chart below for proper motor sizing.

		Altitude / Ambient Temperature Derating Chart						
		Altitude - Meters (Feet) Above Sea Level						
		1000 (3281)	1500 (4921)	2000 (6562)	2500 (8202)	3000 (9842)	3500 (11,483)	4000 (13,123)
Temperature - °C (°F)	10°C (50°F)	-	-	-	-	-	-	1.50
	15°C (59°F)	-	-	-	-	-	1.05	0.99
	20°C (68°F)	-	-	-	-	1.05	0.99	0.93
	25°C (77°F)	-	-	-	1.05	0.98	0.93	0.88
	30°C (86°F)	-	-	1.05	0.97	0.92	0.87	0.82
	40°C (104°F)	1.00	0.94	0.89	0.85	0.80	0.76	0.72
	50°C (122°F)	0.85	0.8	0.76	0.72	0.68	0.65	0.62
	60°C (140°F)	0.71	0.67	0.64	0.60	0.57	0.55	0.52

Example: 100hp @ 60°C and 2000 Meters
 100 / 0.64 = 156hp
 The motor should be a 200hp motor.

COUPLING ALIGNMENT

Correct coupling alignment is very important to the life of the motor. Coupling misalignment is the major cause of motor bearing failure. In belt driven applications, pulleys should be installed correctly. Belt tension, alignment, and wear should be checked at installation and at regular maintenance intervals. Install motor couplings per the manufacturers instructions. Whenever possible, direct couple or flange mount IronHorse motors in their application. Doing so can extend the bearing life greatly.

AutomationDirect offers C-face mounting kits for all PE and EAct T-frame IronHorse motors. For a complete list of mounting kits, see Chapter 4 (Accessories).

MOTOR NAMEPLATE & STARTER INFORMATION

TYPICAL IRONHORSE® MOTOR NAMEPLATE

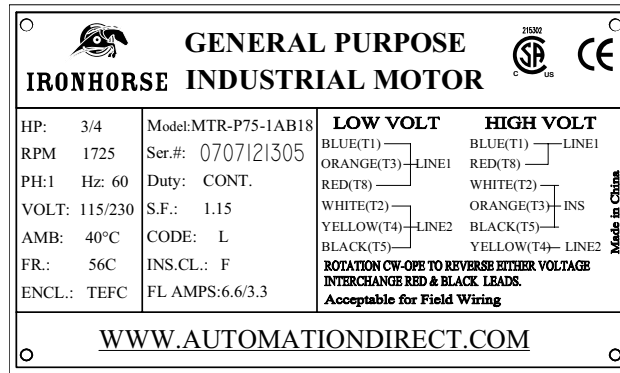

MOTOR STARTER INFORMATION

IronHorse® general purpose motors can be controlled by across-the-line starters such as contactors and manual motor starters. Under certain circumstances, three phase IronHorse motors can also be controlled by AC drives. Refer to Chapter 5 (Reference) for more information about using AC drives with IronHorse motors.

Use the following chart to help determine the appropriate across-the-line starter.

Starting System Information						
Frame Size *	Number of Internal Leads	Internal Lead Size	Internal Lead Length	Voltage	Winding Type	
56C (1Ø)	6	16 AWG	6 in	115/208-230	N/A	
56C (3Ø)	9		14 AWG		9-1/2 in	Wye
143T – 145T						Delta
182T – 184T						
213T		12		10 AWG		10-5/8 in
215T						
254T – 256T	12 AWG					
284T – 286T	8 AWG					
324T – 326T	6 AWG					
364T – 365T	4 AWG					
404T – 405T	3 AWG		13 in			
444T – 445T		13-3/4 in				
447T						
449T	6	1 AWG	14 in	460		

* TC-frame motors have the same starting system characteristics as the comparable T-frame motors.

LOCKED ROTOR AMPS

All electrical components used in an IronHorse motor installation must be able to handle the maximum current draw of the motor. When using a typical across-the-line starter, current is highest when power is first applied to the motor. This is commonly referred to as locked rotor amps. Every IronHorse motor has a locked rotor amperage code letter stamped on the motor nameplate either as “CODE” or “kVA Code”. This letter applies to the locked rotor amp range value. See the motor “Performance Data” tables in Chapter 1 (Getting Started) for specific locked rotor amperage information.

INSPECTION BEFORE STARTUP

- 1) Remove the shaft lock device if the motor was supplied with one.
- 2) Turn the shaft by hand and make sure the shaft turns freely. Listen for any unusual noises and feel for any interruption in the shaft as it turns.
- 3) In all motors with serviceable bearings, check the grease level on both drive end and opposite drive end bearings. Make sure the bearing cavities are filled with Mobil POLYREX® EM Polyurea grease. MTCP2 motors should be greased using SKF, LGHP2 grease. Motors of frame size 250 and above have grease fittings at the 12:00 o'clock position and relief ports at the 7:00 o'clock position. For these motors, remove the plugs from the relief ports, and pump 12 to 13 pumps of grease into the grease fittings. Some grease may come out of the relief port; this is normal. Reinstall the plug in the relief port.



When replacing a T-frame end bell with a C-face end bell, transfer the grease fitting and plug from the original to the new end bell.

- 4) Perform a final check on the installation of all parts in the assembly. Check the motor mounting bolts, coupling, belt drive, C-face mount, alignment, etc.
- 5) Verify all electrical connections for the motor and starter. Refer to the motor diagram on the motor nameplate. Make sure all terminal screws are tightened properly.
- 6) Make sure that all electrical components used in the installation are rated for the locked rotor amperage.
- 7) Make sure the motor is properly grounded. Use the grounding lug provided in the motor terminal box or on the mounting foot.

INITIAL STARTUP INSPECTION

- 1) At initial startup monitor the start-up voltage and the running voltage of the motor. The full load voltage should never exceed the line voltage on the motor nameplate multiplied by the service factor of the motor.
Example: 230 VAC x 1.15 = 264.5 VAC.
- 2) Check the full load running amperage (FLA) of the motor. The full load running amperage should not be more than the amount indicated on the motor nameplate
- 3) Listen for any unusual noises at motor start-up and in the first hour of operation. Listen for any unusual bearing noise in the drive end and opposite drive end of the motor. Abnormal bearing noise can be an indication of a defective bearing or the motor grease could be low. If there is abnormal noise in motors with serviceable bearings, shut down the motor and check the grease level on both the drive end and opposite drive end.



DO NOT OVER GREASE THE BEARINGS. OVER GREASING MOTOR BEARINGS IS A COMMON CAUSE OF MOTOR FAILURE.



Large horsepower motors with roller bearings will typically be noisier than ball bearing motors at initial motor start-up and in normal operation.

MAINTENANCE



CHAPTER

3

TABLE OF CONTENTS

<i>Routine Maintenance</i>3-2
<i>Bearing Size Information</i>3-3

ROUTINE MAINTENANCE

A routine maintenance schedule should be developed for every IronHorse® motor installation based on the individual application. Motors installed in a harsh running environment should be serviced more frequently than those installed in a clean, climate controlled area. Use the following to create a schedule.

- 1) Clean the motor housing using a brush, soft cloth or compressed air. Pay special attention to the cooling ribs on cast iron motors. Remove any dirt and dust from the fan and fan cover vents.
- 2) Frequently monitor the bearing temperature on the motor. It should not exceed 60°C (140°F).
- 3) Have the insulation checked periodically by an authorized motor specialist.
- 4) (Applicable only for certain motors, per Note 1 of table shown below):
Lubricate the bearings using the schedule shown below.
- 5) (Applicable only for certain motors, per Note 1 of table shown below):
Purge the bearing grease at least every six months on all motors with serviceable bearings. Replace both the drive end and opposite drive end bearings at the end of their recommended running hour life. Motors used in belt drive applications have a bearing life expectancy of 50,000 hours. Direct coupled application motors have a bearing life expectancy of 100,000 hours.

Bearing Lubrication Schedule				
HP(1)	Drive End Bearing Lubrication(2)	Grease Amount(3)	Opposite Drive End Bearing Lubrication(2)	Grease Amount(3)(4)
15	9000	0.46 oz	9000	0.29 oz
20				
25	7500	0.64 oz		
30				
40	7000	0.75 oz	7500	0.64 oz
50				
60	6500	0.86 oz	7000	0.75 oz
75				
100	3000	1.22 oz	6500	0.86 oz
125	2500	1.47 oz	6500	
150				
200	2300	1.61 oz	2300	1.61 oz
250	2100	1.82 oz		
300				

1) Motors from 1/3 hp to 10 hp, and all MTSS stainless-steel motors have non-serviceable permanently-sealed bearings.
 2) Running time in hours.
 3) Use only Mobil POLYREX® EM Polyurea grease.
 4) For MTCP2 motors, use only SKF LGHP2 grease.
 5) For MTDP motors, use Multemp SRL grease or equivalent.

- 6) MTSS stainless-steel motor bearings should be replaced between 15,000 and 20,000 hours of use (depending upon the severity of use).

BEARING SIZE INFORMATION

All IronHorse® cast-iron motors use premium name-brand bearings (NSK, NTN, or SKF). Below is a bearing size chart listing the type of bearings used in each frame size of IronHorse motors. The bearing types are also listed on the motor nameplate.

Bearing Size Chart									
Frame Size *	Drive End Bearing				Opposite Drive End Bearing				
	MTF Motors	Other IronHorse Motors (Except MTF)	MTF2	MTDP	MTF Motors	MTR2/MTRP /MTRJ Motors	MTCP2 Motors	MTF2	MTDP
56(H)C		6203-ZZ or 6205				6203-ZZ	-		-
143T	-	6205-ZZ	-	6205	-	-	6205-ZZ	-	6204
145T				6205					
182T	6206-ZZ	6306-ZZ	6306	6306	6205-ZZ		6206-ZZ	6206	6305
184T	6206-ZZ			6306	6306			6206-ZZ	6205
213T	-	6308-ZZ	-	6308			6207-ZZ		6306
215T				6308	6308				6206
254T		6309		6309			6209		6307
256T					6309				
284T		6311		6311			6309		6310
286T					6311				
324T		6312		6314			6311		6212
326T					6314				
364T	-	6313	-		-		6312	-	
365T									
404T		NU316					6313		-
405T									
444T		NU318							
445T									
445/7T		NU319							
449T		NU320				6320			

* TC-frame motors have the same bearings as the comparable T-frame motors.

BLANK
PAGE

ACCESSORIES



CHAPTER

4

TABLE OF CONTENTS

<i>Replacement Parts</i>	4-2
<i>Junction boxes, c-flanges, Drive Bells, and Current Diverter Rings for IronHorse® MTDP Drip-Proof Three-Phase Motors</i>	4-2
<i>Capacitors and Centrifugal Switches for IronHorse® Single-Phase Motors</i>	4-4
<i>Spare/Replacement Parts for MTF2 Single-Phase Farm-Duty Motors</i>	4-4
<i>Spare/Replacement Parts for MTR2/MTRJ Single-Phase Motors</i>	4-6
<i>Spare/Replacement Parts for MTR2/MTRP/MTRJ Three-Phase Motors</i>	4-7
<i>Spare/Replacement Parts for MTCP2 Premium-Efficiency Three-Phase Motors</i>	4-8
<i>C-Flange Kits</i>	4-10
<i>C-Flange Kits for MTCP2 Premium-Efficiency Three-Phase Motors</i>	4-10
<i>STABLE™ Slide Bases</i>	4-12
<i>Slide Base Selection</i>	4-13
<i>Slide Base Dimensions</i>	4-14

REPLACEMENT PARTS

JUNCTION BOXES, C-FLANGES, DRIVE BELLS, AND CURRENT DIVERTER RINGS FOR IRONHORSE® MTDP DRIP-PROOF THREE-PHASE MOTORS

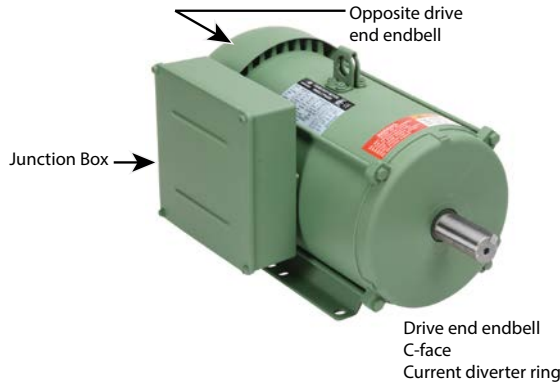

There are a variety of spare / replacement parts for the IronHorse, MTDP, open drip-proof motors. Replacement junction boxes, c-face kits, drive end and opposite drive end bells are available for all frame sizes. "CDR" current diverter rings are also available for use with these motors.

MTDP Three-Phase Motor Spare/Replacement Parts			
Part Number	Accessory Type	For Use With	Motor HP
MTADP-JBOX-140	Junction Box	56 and 140T frame ODP motors	1, 1.5, 2, 3 HP
MTADP-JBOX-180		180T frame ODP motors	3, 5, 7.5HP
MTADP-JBOX-210		210T frame ODP motors	7.5, 10HP
MTADP-JBOX-250		250T frame ODP motors	15, 20HP
MTADP-JBOX-280		280T frame ODP motors	25, 30HP
MTADP-JBOX-320		320T frame ODP motors	40, 50HP
MTADP-CFACE-140TC	C-face	140T frame ODP motors	1, 1.5, 2 HP
MTADP-CFACE-180TC		180T frame ODP motors	3, 5
MTADP-CFACE-210TC		210T frame ODP motors	7.5, 10
MTADP-CFACE-250TC		250T frame ODP motors	15, 20
MTADP-CFACE-280TC		280T frame ODP motors	25, 30
MTADP-CFACE-320TC		320T frame ODP motors	40, 50
MTADP-DEB-140	Drive end endbell	140T frame ODP motors	1, 1.5, 2 HP
MTADP-DEB-180		180T frame ODP motors	3, 5
MTADP-DEB-210		210T frame ODP motors	7.5, 10
MTADP-DEB-250		250T frame ODP motors	15, 20
MTADP-DEB-280		280T frame ODP motors	25, 30
MTADP-DEB-320		320T frame ODP motors	40, 50
MTADP-OEB-140	Opposite drive end endbell	140T frame ODP motors	1, 1.5, 2 HP
MTADP-OEB-180		180T frame ODP motors	3, 5
MTADP-OEB-210		210T frame ODP motors	7.5, 10
MTADP-OEB-250		250T frame ODP motors	15, 20
MTADP-OEB-280		280T frame ODP motors	25, 30
MTADP-OEB-320		320T frame ODP motors	40, 50
*** TABLE CONTINUED NEXT PAGE ***			

*** TABLE CONTINUED FROM PREVIOUS PAGE ***

MTDP Three-Phase Motor Spare/Replacement Parts			
Part Number	Accessory Type	For Use With	Motor HP
MTADP-CDR-140	Current diverter ring	140T frame ODP motors	1, 1.5, 2
MTADP-CDR-180		180T frame ODP motors	3, 5
MTADP-CDR-210		210T frame ODP motors	7.5, 10
MTADP-CDR-250		250T frame ODP motors	15, 20
MTADP-CDR-280		280T frame ODP motors	25, 30
MTADP-CDR-320		320T frame ODP motors	40, 50



Current Diverter Ring

CAPACITORS AND CENTRIFUGAL SWITCHES FOR IRONHORSE® SINGLE-PHASE MOTORS

Single-phase motors use capacitors to provide starting torque when power is first applied to the motor. When the motor begins to turn, the start capacitor is no longer needed and is taken out of the circuit by a centrifugal switch. In addition to the start capacitor, 1-1/2 hp and larger IronHorse single-phase motors have run capacitors to allow the motor to develop higher running torque and greater efficiency. Run capacitors also help improve the motor power factor.

MTF2 ACCESSORY LOCATIONS

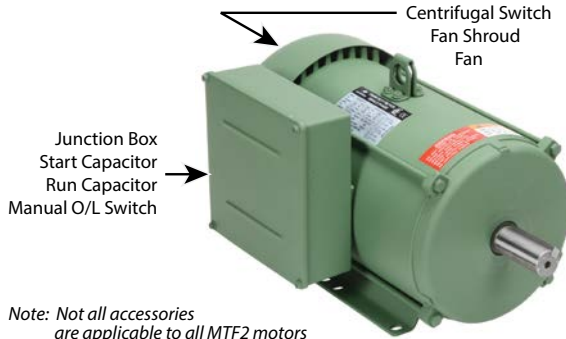

Note: Not all accessories are applicable to all MTF2 motors

MTR2/MTRJ ACCESSORY LOCATIONS

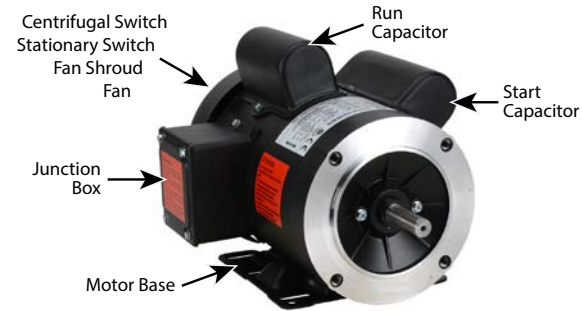

Note: Not all accessories are applicable to all MTR and MTR2 motors

SPARE/REPLACEMENT PARTS FOR MTF2 SINGLE-PHASE FARM-DUTY MOTORS

MTF2 Single-Phase Motor Spare/Replacement Parts						
Part Number	Accessory Type	Capacitance (µF)	Rated Voltage	Dimension Height x Ø (in[mm])	Applicable Motor Number	Motor HP
MTAF2-CAP-16	Start capacitor	250	300	3.39 x 1.81 [86.1 x 46.0]	MTF2-002-1B18-182, MTF2-003-1B18	2, 3
MTAF2-CAP-17		550		3.39 x 1.81 [86.1 x 46.0]	MTF2-005-1B18	5
MTAF2-CAP-18		400	330	4.33 x 1.97 [110.0 x 50.0]	MTF2-7P5-1B18	7.5
MTAF2-CAP-19	Run capacitor	550	330	3.96 x 1.77 [100.6 x 45.0]	MTF2-010-1B18-182	10
MTAF2-CAP-20		25	450	3.96 x 1.97 [100.6 x 50.0]	MTF2-002-1B18	2
MTAF2-CAP-21		30	450	4.17 x 1.97 [106.0 x 50.0]	MTF2-003-1B18	3
MTAF2-CAP-22		50	450	3.54 x 2.00 [90 x 51]	MTF2-005-1B18	5
MTAF2-CAP-23		45	500	4.25 x 2.12 [105 x 54]	MTF2-7P5-1B18-215	7.5
MTAF2-CAP-24		60	500	4.72 x 1.95 [120 x 50]	MTF2-010-1B18	10
MTAF2-CSW-05		Centrifugal switch	n/a	n/a	n/a	MTF2-002-1B18-182, MTF2-003-1B18, MTF2-005-1B18
MTAF2-CSW-06	250					MTF2-7P5-1B18-215
MTAF2-SSW-05	Stationary Switch	n/a	n/a	n/a	MTF2-002-1B18-182, MTF2-003-1B18, MTF2-005-1B18	2,3, 5
MTAF2-SSW-06					n/a	MTF2-7P5-1B18-215, MTF2-010-1B18
MTAF2-MOL-1	Manual overload switch	n/a	n/a	n/a	MTF2-002-1B18-182	2
MTAF2-MOL-2					MTF2-003-1B18	3
MTAF2-MOL-3					MTF2-005-1B18	5
MTAF2-MOL-4					MTF2-7P5-1B18-215	7.5
MTAF2-MOL-5					MTF2-010-1B18	10

*** TABLE CONTINUED NEXT PAGE ***

*** TABLE CONTINUED FROM PREVIOUS PAGE ***

MTF2 Single-Phase Motor Spare/Replacement Parts						
Part Number	Accessory Type	Capacitance (μF)	Rated Voltage	Dimension Height x Ø (in[mm])	Applicable Motor Number	Motor HP
MTF2-CFACE-180TC	C-face kit	n/a	n/a	n/a	MTF2-002-1B18-182 MTF2-003-1B18 MTF2-005-1B18	2, 3, 5
MTF2-CFACE-210TC		n/a	n/a	n/a	MTF2-7P5-1B18-215 MTF2-010-1B18	7.5, 10
MTAF2-JBOX-180	Junction box	n/a	n/a	n/a	MTF2-002-1B18-182 MTF2-003-1B18 MTF2-005-1B18	2, 3, 5
MTAF2-JBOX-210		n/a	n/a	n/a	MTF2-7P5-1B18-215 MTF2-010-1B18	7.5, 10
MTAF2-FAN-180	Fan		n/a	n/a	MTF2-002-1B18-182 MTF2-003-1B18 MTF2-005-1B18	2, 3, 5
MTAF2-FAN-210			n/a	n/a	MTF2-7P5-1B18-215 MTF2-010-1B18	7.5, 10
MTAF2-SHROUD-180	Fan shroud		n/a	n/a	MTF2-002-1B18-182 MTF2-003-1B18 MTF2-005-1B18	2, 3, 5
MTAF2-SHROUD-210			n/a	n/a	MTF2-7P5-1B18-215 MTF2-010-1B18	7.5, 10

MTF2 Single-Phase Motor Spare/Replacement Parts						
ADC Part Number	Manufacturer Part Number	Temperature Rating - Deg C		Current	Short Time Rating	
		Open +/-5	Closed +/-9		Min (Sec)	Max (Sec)
MTAF2-MOL-1	BEH-70KB 79A 60/230V KWE	120	74	59	6.5	16
MTAF2-MOL-2	BEH-42KB 89A 60/230V KWE	120	74	70.6	6.5	16
MTAF2-MOL-3	LEH-31JD 171A 60/230V KWE	135	96	129	6.5	16
MTAF2-MOL-4	LEH-28KD 238A 60/230V KWE	135	96	190	11	20.5
MTAF2-MOL-5	LEH-00BB 366A 60/230V KWE	120	74	203	10	21.5

CAPACITORS AND CENTRIFUGAL SWITCHES FOR IRONHORSE SINGLE-PHASE MOTORS (CONTINUED)

SPARE/REPLACEMENT PARTS FOR MTR2/MTRJ SINGLE-PHASE MOTORS

MTR2/MTRJ Single-Phase Motor Spare/Replacement Parts (NOT for MTR Motors)*							
Part Number	Accessory Type	Capacitance (μF)	Rated Voltage	Dimension Height x Ø (in [mm])	Applicable MTR2 Motor Number	MTR2 Motor HP ; RPM	
MTA-CAP-10	Start Capacitor	200	165	2.80 x 1.46 [71.1 x 37.1]	MTR2-P33-1AB36 MTRJ-001-1AB36J	1/3 : 3600 1 : 3600	
MTA-CAP-11	Start Capacitor	300		3.39 x 1.85 [86.1 x 47.0]	MTR2-P33-1AB18 MTR2-P50-1AB36 MTRJ-1P5-1AB36J	1/3: 1800 1/2 : 3600 1 1/2 : 3600	
MTA-CAP-12	Start Capacitor	400			MTR2-P50-1AB18 MTR2-P75-1AB36 MTRJ-002-1AB36J	1/2: 1800 3/4 : 3600 2 : 3600	
MTA-CAP-13	Start Capacitor	500			MTR2-P75-1AB18 MTR2-001-1AB18 MTR2-001-1AB36	3/4: 1800 1: 1800 1 : 3600	
MTA-CAP-14	Run Capacitor	40	250	3.38 x 1.81 [85.9 x 46.0]	MTR2-1P5-1ABxx MTR2-002-1ABxx	1 1/2 : all 2 : all	
MTA-CAP-15	Start Capacitor	800	165	4.41 x 1.85 [112.0 x 47.0]	MTRJ-1P5-1AB36J MTRJ-002-1AB36J	1 1/2 : 3600 2 : 3600	
MTA-CAP-22	Start Capacitor	900	165	4.375 x 1.8125 [111.1 x 46.0]	MTR2-1P5-1AB18	1-1/2 : 1800	
MTA-CAP-31	Start Capacitor	150	165	3.39 x 1.85 [86.1 x 47.0]	MTRJ-P33-1AB36J MTRJ-P50-1AB36J MTRJ-P75-1AB36J	1/3 : 3600 1/2 : 3600 3/4 : 3600	
MTA-CSW-03	Centrifugal Switch	n/a	125	n/a	MTR2-xxx-1AB36	all 3600 rpm	
MTA-CSW-04	Stationary Switch				MTR2-xxx-1ABxx	all	
MTA-CSW-08	Centrifugal Switch				MTR2-xxx-1AB18	all 1800 rpm	
MTA2-BASE-56	Motor Base		n/a		n/a	MTR2-xxx-1ABxx MTRJ-xxx-1ABxx	all
MTA2-FAN-56	Fan						
MTA2-JBOX-56	Junction Box						
MTA2-SHROUD-56	Fan Shroud						

* These accessories are spare/replacement components only for MTR2 series IronHorse motors. Accessories for MTR2 series motors are NOT compatible with MTR series motors.

SPARE/REPLACEMENT PARTS FOR MTR2/MTRP/MTRJ THREE-PHASE MOTORS

IronHorse bases, fans, and fan shrouds are available as direct replacement parts for MTR2, and MTRP motors.

These parts are field installable, and include installation instructions.



Fan



Fan Shroud



Junction Box



Motor Base



Fan

MTR2/MTRP/MTRJ Series Three-Phase Motor Spare/ Replacement Part*			
Part Number	Description	Applicable MTRP Motor Number	MTR2/MTRP Motor HP : RPM
MTA2-BASE-56	Motor base	MTRP-xxx-3BDxx MTR2-Pxx-3BDxx MTRJ-Xxx-3BDxx	All
MTA2-JBOX-56	Junction box		
MTA2-SHROUD-56	Fan shroud		
MTA2-FAN-56	Fan	MTR2-Pxx-3BDxx MTRJ-Xxx-3BDxx	
MTA2-FAN-56-1	Fan	MTRP-xxx-3BDxx MTRJP-Xxx-3BDxx	

* These accessories are spare/replacement components only for MTR2/ MTRP series IronHorse motors.

SPARE/REPLACEMENT PARTS FOR MTCP2 PREMIUM-EFFICIENCY THREE-PHASE MOTORS

IronHorse junction boxes, TEFC fans, and TEFC fan shrouds are available as direct replacement parts for MTCP2 motors.

These parts are field installable, and include installation instructions.



Fan



Fan Shroud



Junction Box

MTCP2 Premium-Efficiency Three-Phase Motor Replacement Parts					
Part Number (1)	Description (2)(3)(4)	Fits Frame	Fits PE Motor Number (1)	Motor HP	Product Weight (lb)
MTAP2-FAN-140	Replacement Fan	143 & 145	MTCP2-001-3BD12	1	0.029
MTAP2-SHROUD-140	Replacement Fan Shroud		MTCP2-001-3BD18(C)	1	
MTAP2-JBOX-140	Replacement Junction Box		MTCP2-1P5-3BD18(C)	1-1/2	1.04
		MTCP2-1P5-3BD36	1-1/2		
MTAP2-FAN-180	Replacement Fan	182 & 184	MTCP2-002-3BD18(C)	2	2.54
	MTAP2-SHROUD-180		Replacement Fan Shroud	MTCP2-002-3BD36	
MTAP2-FAN-180	Replacement Fan		MTCP2-003-3BD18(C)	3	0.053
			MTCP2-003-3BD36	3	
MTAP2-SHROUD-180	Replacement Fan Shroud	MTCP2-005-3BD18(C)	5	2.23	
		MTCP2-005-3BD36	5		
MTAP2-JBOX-180	Replacement Junction Box				3.28
MTAP2-FAN-210-2	Replacement Fan (for 2-pole motors)	213 & 215	MTCP2-7P5-3BD36	7-1/2	0.075
MTAP2-FAN-210	Replacement Fan (4&6-pole)		MTCP2-010-3BD36	10	
MTAP2-SHROUD-210	Replacement Fan Shroud		MTCP2-003-3BD12	3	0.075
			MTCP2-005-3BD12	5	
MTAP2-JBOX-210	Replacement Junction Box	MTCP2-7P5-3BD18(C)	7-1/2	4.98	
		MTCP2-010-3BD18(C)	10		

1) These MTAP2 replacement components fit only MTCP2 Premium-Efficiency motors; they will NOT fit MTC EPart motors.
 2) Replacement fans include fan, snap ring, and instructions.
 3) Replacement fan shrouds include shroud, bolts w/washers, rubber plug, and instructions.
 4) Replacement junction boxes include gasketed base & cover assembly, base gasket, base bolts, and instructions.

*** TABLE CONTINUED NEXT PAGE ***

SPARE/REPLACEMENT PARTS FOR MTCP2 PREMIUM-EFFICIENCY 3-PHASE MOTORS (CONTINUED)

*** TABLE CONTINUED FROM PREVIOUS PAGE ***					
MTCP2 Premium-Efficiency Three-Phase Motor Replacement Parts					
Part Number (1)	Description (2)(3)(4)	Fits Frame	Fits PE Motor Number (1)	Motor HP	Product Weight (lb)
MTAP2-FAN-250-2	Replacement Fan (for 2-pole motors)	254 & 256	MTCP2-015-3BD36 MTCP2-020-3BD36	15 20	0.090
MTAP2-FAN-250	Replacement Fan (4&6-pole)		MTCP2-7P5-3BD12	7-1/2	0.104
MTAP2-SHROUD-250	Replacement Fan Shroud		MTCP2-010-3BD12	10	8.27
MTAP2-JBOX-250	Replacement Junction Box		MTCP2-015-3BD18(C) MTCP2-020-3BD18(C)	15 20	8.16
MTAP2-FAN-280	Replacement Fan	284 & 286	MTCP2-015-3BD12	15	0.090
MTAP2-SHROUD-280	Replacement Fan Shroud		MTCP2-020-3BD12	20	10.03
MTAP2-JBOX-280	Replacement Junction Box		MTCP2-025-3BD18(C) MTCP2-030-3BD18(C)	25 30	8.16
MTAP2-FAN-320	Replacement Fan	324 & 326	MTCP2-040-3BD18 MTCP2-050-3BD18	40 50	0.126
MTAP2-SHROUD-320	Replacement Fan Shroud				12.50
MTAP2-JBOX-320	Replacement Junction Box				23.59
MTAP2-FAN-360	Replacement Fan	364 & 365	MTCP2-060-3BD18 MTCP2-075-3BD18	60 75	0.126
MTAP2-SHROUD-360	Replacement Fan Shroud				13.76
MTAP2-JBOX-360	Replacement Junction Box				21.05
MTAP2-FAN-400	Replacement Fan	405	MTCP2-100-3BD18	100	0.150
MTAP2-SHROUD-400	Replacement Fan Shroud				16.67
MTAP2-JBOX-400	Replacement Junction Box				32.74
MTAP2-FAN-440	Replacement Fan	444 & 445 & 447	MTCP2-125-3BD18 MTCP2-150-3BD18 MTCP2-200-3BD18	125 150 200	0.150
MTAP2-SHROUD-440	Replacement Fan Shroud				17.97
MTAP2-JBOX-440	Replacement Junction Box				36.49
MTAP2-FAN-449	Replacement Fan (250hp)	449	MTCP2-250-3D18 MTCP2-300-3D18	250 300	0.205
MTAP2-FAN-449-1	Replacement Fan (300hp)				0.174
MTAP2-SHROUD-449	Replacement Fan Shroud				22.27
MTAP2-JBOX-449	Replacement Junction Box				36.49

1) These MTAP2 replacement components fit only MTCP2 Premium-Efficiency motors; they will NOT fit MTC EPart motors.
 2) Replacement fans include fan, snap ring, and instructions.
 3) Replacement fan shrouds include shroud, bolts w/washers, rubber plug, and instructions.
 4) Replacement junction boxes include gasketed base & cover assembly, base gasket, base bolts, and instructions.

C-FLANGE KITS

C-FLANGE KITS FOR MTCP2 PREMIUM-EFFICIENCY THREE-PHASE MOTORS

C-FLANGE KITS

Any IronHorse MTCP2 Premium-Efficiency T-frame cast-iron motor from 1–300 hp can be converted to C-face mounting by using a cast iron C-flange kit. These kits are field installable and include the C-faces and mounting bolts.



MTAP2 T-Frame C-Flange Kit

C-FLANGE DIMENSIONS

C-flange dimensions are shown in Chapter 2 (Mounting & Initial Startup) along with TC-frame motor dimensions.



Authorized EASA service centers are equipped with the necessary equipment to quickly and inexpensively install C-Face kits. Visit the EASA website at www.easa.com to find the nearest authorized service center.

C-faces must be installed by an EASA motor shop in order to maintain the motor warranty.

MTCP2 Premium-Efficiency T-frame Three-Phase Motor C-Flange Kits				
Part Number (1)	Fits Frame	Fits Motor (1)	Motor HP	Product Weight (lb)
MTAP2-CFACE-140TC	143T & 145T	MTCP2-001-3BD12	1	5.62
		MTCP2-001-3BD18	1	
		MTCP2-1P5-3BD18	1-1/2	
		MTCP2-1P5-3BD36	1-1/2	
		MTCP2-002-3BD18	2	
		MTCP2-002-3BD36	2	
MTAP2-CFACE-180TC	182T & 184T	MTCP2-1P5-3BD12	1-1/2	10.36
		MTCP2-002-3BD12	2	
		MTCP2-003-3BD18	3	
		MTCP2-003-3BD36	3	
		MTCP2-005-3BD18	5	
		MTCP2-005-3BD36	5	
MTAP2-CFACE-210TC	213T & 215T	MTCP2-003-3BD12	3	12.68
		MTCP2-005-3BD12	5	
		MTCP2-7P5-3BD18	7-1/2	
		MTCP2-7P5-3BD36	7-1/2	
		MTCP2-010-3BD18	10	
		MTCP2-010-3BD36	10	
MTAP2-CFACE-250TC	254T & 256T	MTCP2-7P5-3BD12	7-1/2	31.20
		MTCP2-010-3BD12	10	
		MTCP2-015-3BD18	15	
		MTCP2-015-3BD36	15	
		MTCP2-020-3BD18	20	
		MTCP2-020-3BD36	20	
1) MTAP2-CFACE C-flange kits will NOT fit MTC EPAAct motors.				
*** TABLE CONTINUED NEXT PAGE ***				

C-FLANGE KITS FOR MTCP2 PREMIUM-EFFICIENCY THREE-PHASE MOTORS (CONTINUED)

*** TABLE CONTINUED FROM PREVIOUS PAGE ***				
MTCP2 Premium-Efficiency T-frame Three-Phase Motor C-Flange Kits				
Part Number (1)	Fits Frame	Fits Motor (1)	Motor HP	Product Weight (lb)
MTAP2-CFACE-280TC	284T & 286T	MTCP2-015-3BD12 MTCP2-020-3BD12 MTCP2-025-3BD18 MTCP2-030-3BD18	15 20 25 30	31.20
MTAP2-CFACE-320TC	324T & 326T	MTCP2-040-3BD18 MTCP2-050-3BD18	40 50	47.40
MTAP2-CFACE-360TC	364T & 365T	MTCP2-060-3BD18 MTCP2-075-3BD18	60 75	48.70
MTAP2-CFACE-400TC	405T	MTCP2-100-3BD18	100	132.17
MTAP2-CFACE-444TC	444T & 445T	MTCP2-125-3BD18 MTCP2-150-3BD18	125 150	137.44
MTAP2-CFACE-447TC	445/7T	MTCP2-200-3BD18	200	134.83
MTAP2-CFACE-449TC	449T	MTCP2-250-3D18 MTCP2-300-3D18	250 300	162.50
1) MTAP2-CFACE C-flange kits will NOT fit MTC EPAct motors.				

STABLE™ SLIDE BASES

AutomationDirect offers STABLE AC motor adjustable slide bases for mounting most AC motor brands with frame sizes from 56 to 449. These heavy duty steel bases are primed with an oven-baked primer ready for painting. The motor mounting bolts are welded to the exact motor foot pattern to prevent the bolts from spinning.



SLIDE BASE SELECTION

STABLE™ Motor Slide Bases			
Part Number	Fits Frame Type	Product Weight (lb)	IronHorse Model
MTA-BASE-W56*	56C*	2.8	MTR2-xxx-xxxxx*, MTRP-xxx-xxxxx
MTA-BASE-W143T	143T/TC	4.6	MTCP2-001-3BD18(C)(CK), MTCP2-1P5-3BD36 MTDP-001-3BD18
MTA-BASE-W145T	145T/TC	5.1	MTCP2-001-3BD12 MTCP2-1P5-3BD18(C)(CK) MTCP2-002-3BD18(C)(CK) MTCP2-002-3BD36, MTDP-1P5-3BD18 MTDP-002-3BD18, MTDP-003-3BD36
MTA-BASE-W182T	182T/TC	9.2	MTCP2-1P5-3BD12 MTCP2-003-3BD18(C)(CK) MTCP2-003-3BD36, MTF-002-1C18-182 MTF2-002-1B18-182, MTDP-003-3BD18 MTDP-005-3BD36, MTF2-002-1B18-182
MTA-BASE-W184T	184T/TC	10	MTCP2-002-3BD12 MTCP2-005-3BD18(C)(CK) MTCP2-005-3BD36 MTF-00x-1C18, MTF2-002-1B18-182 MTDP-005-3BD18, MTDP-7P5-3BD36 MTF2-003-1B18, MTF2-005-1B18
MTA-BASE-W213T	213T/TC	13	MTCP2-003-3BD12 MTCP2-7P5-3BD18(C)(CK) MTCP2-7P5-3BD36 MTDP-7P5-3BD18
MTA-BASE-W215T	215T/TC	15	MTCP2-005-3BD12 MTCP2-010-3BD18(C)(CK) MTCP2-010-3BD36 MTF2-010-1818, MTDP-010-3BD18 MTF2-7P5-1B18-215, MTF-010-1B18
MTA-BASE-W254T	254T/TC	18	MTCP2-7P5-3BD12 MTCP2-015-3BD18(C)(CK) MTCP2-015-3BD36, MTDP-015-3BD18
MTA-BASE-W256T	256T/TC	19	MTCP2-010-3BD12 MTCP2-020-3BD18(C)(CK) MTCP2-020-3BD36, MTDP-020-3BD18
MTA-BASE-W284T	284T/TC	20	MTCP2-015-3BD12 MTCP2-025-3BD18(C)(CK) MTDP-025-3BD18
MTA-BASE-W286T	286T/TC	21	MTCP2-020-3BD12 MTCP2-030-3BD18(C)(CK) MTDP-030-3BD18
MTA-BASE-W324T	324T/TC	30	MTCP2-040-3BD18(C)(CK), MTDP-040-3BD18
MTA-BASE-W326T	326T/TC	31	MTCP2-050-3BD18(C)(CK), MTDP-050-3BD18
MTA-BASE-W364T	364T/TC	43	MTCP2-060-3BD18(C)(CK)
MTA-BASE-W365T	365T/TC	43	MTCP2-075-3BD18(C)(CK)
MTA-BASE-W404T	404T/TC	58	-
MTA-BASE-W405T	405T/TC	60	MTCP2-100-3BD18(C)(CK)
MTA-BASE-W444T	444T	63	MTCP2-125-3BD18
MTA-BASE-W445T	445T	65	MTCP2-150-3BD18
MTA-BASE-W447T	447T	89	MTCP2-200-3BD18
MTA-BASE-W449T	449T	94	MTCP2-250-3D18 MTCP2-300-3D18

* IronHorse MTR2 and MTRP 56HC motors have double-punched bases to mount on slide base MTA-BASE-W56

SLIDE BASE DIMENSIONS

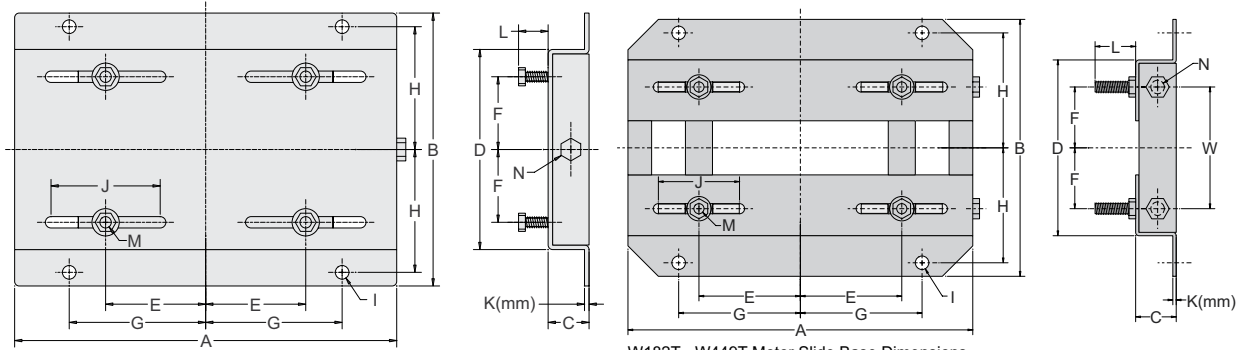

W56 - W145T Motor Slide Base Dimensions

W182T - W449T Motor Slide Base Dimensions
(W182T-W215T bases have one-piece top plates, similar to W56-W145T)

Dimensions [inches, except as noted] - STABLE™ Motor Slide Bases							
MTA-BASE-Wxxxx	A	B	C	D	E	F	G
56	10-5/8	6-1/2	1-1/8	4-1/2	2-7/16	1-1/2	3-13/16
143T	10-1/2	7-1/2	1-1/8	5-1/2	2-3/4	2	3-3/4
145T	10-1/2	8-1/2	1-1/8	6-1/2	2-3/4	2-1/2	3-3/4
182T	12-3/4	9-1/2	1-1/2	6-1/2	3-3/4	2-1/4	4-1/2
184T	12-3/4	10-1/2	1-1/2	7-1/2	3-3/4	2-3/4	4-1/2
213T	15	11	1-3/4	7-1/2	4-1/4	2-3/4	5-1/4
215T	15	12-1/2	1-3/4	9	4-1/4	3-1/2	5-1/4
254T	17-3/4	15-1/8	2	10-3/4	5	4-1/8	6-1/4
256T	17-3/4	16-7/8	2	12-1/2	5	5	6-1/4
284T	19-3/4	16-7/8	2	12-1/2	5-1/2	4-3/4	7
286T	19-3/4	18-3/8	2	14	5-1/2	5-1/2	7
324T	22-3/4	19-1/4	2-1/2	14	6-1/4	5-1/4	8
326T	22-3/4	20-3/4	2-1/2	15-1/2	6-1/4	6	8
364T	25-1/2	20-1/2	2-1/2	15-1/2	7	5-5/8	9
365T	25-1/2	21-1/2	2-1/2	16-1/2	7	6-1/8	9
404T	28-3/4	22-3/8	3	16-1/2	8	6-1/8	10
405T	28-3/4	23-7/8	3	18	8	6-7/8	10
444T	31-1/4	24-5/8	3	19-1/4	9	7-1/4	11
445T	31-1/4	26-5/8	3	21-1/4	9	8-1/4	11
447T	31-1/4	30-1/8	3	24-3/4	9	10	11
449T	31-1/4	35-1/8	3	29-3/4	9	12-1/2	11

**** Table Continued Next Page for Dimensions H-W ****

SLIDE BASE DIMENSIONS (CONTINUED)

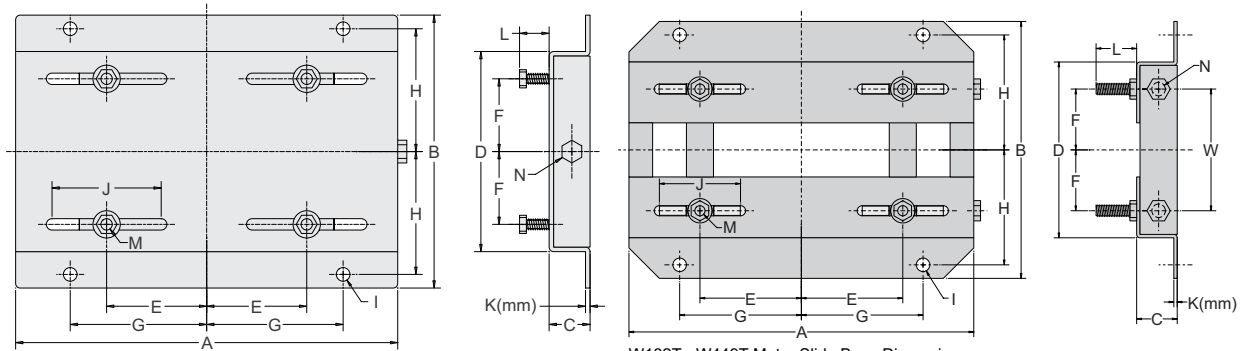

W56 - W145T Motor Slide Base Dimensions

W182T - W449T Motor Slide Base Dimensions
(W182T-W215T bases have one-piece top plates, similar to W56-W145T)

**** Table Continued from Previous Page for Dimensions A-G ****

Dimensions [inches, except as noted] - STABLE™ Motor Slide Bases (continued)								
MTA-BASE-Wxxxx	H	I	J	K(mm)	L	M	N	W
56	2-7/8	3/8	3	2 mm	7/8	5/16 x 1	3/8 x 4	n/a
143T	3-3/8	3/8	3	3 mm	13/16	5/16 x 1	3/8 x 4	n/a
145T	3-7/8	3/8	3	3 mm	13/16	5/16 x 1	3/8 x 4	n/a
182T	4-1/4	1/2	3	3.5 mm	1-1/2	3/8 x 1-3/4	1/2 x 6	4-1/2
184T	4-3/4	1/2	3	3.5 mm	1-1/2	3/8 x 1-3/4	1/2 x 6	5-1/2
213T	4-3/4	1/2	3-1/2	3.8 mm	1-1/2	3/8 x 1-3/4	1/2 x 6	5-1/2
215T	5-1/2	1/2	3-1/2	3.8 mm	1-1/2	3/8 x 1-3/4	1/2 x 6	7
254T	6-5/8	5/8	4	4.6 mm	1-7/16	1/2 x 1-3/4	5/8 x 6	5-5/16
256T	7-1/2	5/8	4	4.6 mm	1-7/16	1/2 x 1-3/4	5/8 x 6	7
284T	7-1/2	5/8	4-1/2	4.6 mm	1-11/16	1/2 x 2	5/8 x 6	7
286T	8-1/4	5/8	4-1/2	4.6 mm	1-11/16	1/2 x 2	5/8 x 6	8
324T	8-1/2	3/4	5-1/4	4.6 mm	2-3/16	5/8 x 2-1/2	3/4 x 9	7
326T	9-1/4	3/4	5-1/4	4.6 mm	2-3/16	5/8 x 2-1/2	3/4 x 9	8-1/2
364T	9-1/8	3/4	6	5.8 mm	2-1/16	5/8 x 2-1/2	3/4 x 9	7-3/4
365T	9-5/8	3/4	6	5.8 mm	2-1/16	5/8 x 2-1/2	3/4 x 9	8-3/4
404T	9-7/8	7/8	7	5.8 mm	2-1/2	3/4 x 3	3/4 x 11	8-3/4
405T	10-5/8	7/8	7	5.8 mm	2-1/2	3/4 x 3	3/4 x 11	10-1/4
444T	11	7/8	7-1/2	5.8 mm	2-1/2	3/4 x 3	3/4 x 11	11
445T	12	7/8	7-1/2	5.8 mm	2-1/2	3/4 x 3	3/4 x 11	13
447T	13-3/4	7/8	7-1/2	8 mm	3	3/4 x 3-1/2	3/4 x 11	16-1/2
449T	16-1/4	7/8	7-1/2	8 mm	3	3/4 x 3-1/2	3/4 x 11	21-1/2

Blank
PAGE

REFERENCE INFORMATION

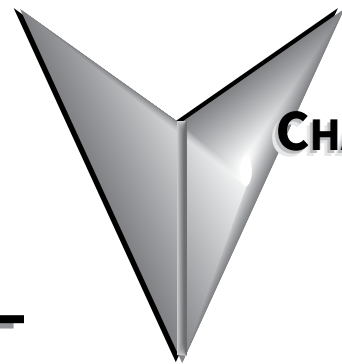

CHAPTER

5

TABLE OF CONTENTS

<i>Using IronHorse® Motors with AC Drives.</i>	<i>.5-2</i>
<i> Voltage Spike Considerations for AC Drive Control.</i>	<i>5-3</i>
<i>Radial Overhung Load</i>	<i>.5-4</i>
<i>F1 and F2 Mounting.</i>	<i>.5-5</i>
<i>Junction Box Dimensions</i>	<i>.5-6</i>
<i>Minimum Sheave Diameters</i>	<i>.5-7</i>
<i>Decibel Levels</i>	<i>.5-8</i>
<i>Shipping Crate Dimensions.</i>	<i>5-10</i>
<i>Performance Curves for MTF2 Motors.</i>	<i>5-11</i>
<i>Performance Curves for MTR2 Motors</i>	<i>5-16</i>
<i>Performance Curves for MTDP Motors</i>	<i>5-34</i>
<i>Performance Curves for MTRP Motors</i>	<i>5-50</i>
<i>Speed/Torque Curves for MTCP2 Motors (1800 RPM)</i>	<i>5-57</i>
<i>Speed/Torque Curves for MTCP2 Motors (1200 RPM)</i>	<i>5-64</i>
<i>Speed/Torque Curves for MTCP2 Motors (3600 RPM)</i>	<i>5-68</i>

USING IRONHORSE® MOTORS WITH AC DRIVES

IronHorse® general purpose motors can be controlled by across-the-line starters such as contactors and manual motor starters. Under certain circumstances, it can be more desirable to control a three-phase IronHorse motor with an AC drive.



Single phase AC motors cannot be controlled by typical AC drives.

The advantages of using an AC drive include:

- *Lower inrush current at motor startup.*
- *Ability to change motor speed at any time.*
- *Greater efficiency in some applications. Fan and Pump applications can use an AC drive to provide motor flow control by varying the motor speed.*
- *Solid state power delivery meaning minimum maintenance.*

There are a few considerations to take into account when an AC drive is chosen for motor control. Fan cooled motors are designed to provide sufficient insulation cooling when the motor is running at the rated speed. The cooling ability of the fan is reduced when motors run at lower speeds. Therefore, there are limitations on how slowly general purpose motors can be continuously run without prematurely causing insulation failure.

- *Constant torque (CT) applications:*
 MTCP and MTRP motors 4:1 (down to 1/4 rated speed); MTC, MTR, & MTSS motors 2:1 (1/2 rated speed); MTCP2, MTDP motors 10:1 (1/10 rated speed):
 The CT minimum continuous speed for an IronHorse general purpose motor is one quarter or one half of its rated speed, as shown in the motor Performance Data tables.
 (Constant torque loads require the same amount of torque from the motor regardless of speed; e.g., conveyors, cranes, machine tools.)
- *Variable Torque (VT) applications:*
 MTCP and MTRP motors 10:1 (1/10 rated speed); MTC, MTR, & MTSS motors 5:1 (1/5 rated speed), MTCP2, MTDP motors 20:1 (1/20 rated speed):
 The VT minimum continuous speed for an IronHorse general purpose motor is one tenth or one fifth of its rated speed, as shown in the motor Performance Data tables.
 (Variable torque loads require less torque at lower speeds, resulting in less heat generated by the motor; e.g., fans, centrifugal pumps.)

The insulation of IronHorse motors in both of the above applications can withstand voltage stress per NEMA Part 30 having a value of:

- *Base Voltage Rating* ≤ 600V
- V_{pk} = 1kV
- *Rise Time* = 2μs



AutomationDirect offers a line of AC Drives that are suitable for operating IronHorse motors per the above specs and NEMA part 30.

VOLTAGE SPIKE CONSIDERATIONS FOR AC DRIVE CONTROL

All AC drives can cause voltage spikes between the drive and the motor. Long cable lengths can increase these spikes. Therefore, there are maximum cable lengths that can be run between the drive and the motor. Line (load) reactors can also be installed near the drive output to reduce the voltage spikes.

- 230V & 460V without reactor: 25ft maximum cable length between the drive and motor.
- 230V & 460V with reactor: Motor dependent - 100ft maximum cable length between the drive and motor.



TO AVOID OVERHEATING, THE AC DRIVE CARRIER FREQUENCY MUST BE SET AT OR BELOW 6KHZ.

Double Punched Motors

Several IronHorse® motor models have mounting feet that are double punched so that additional motors can be mounted using the same dimensions of different size frame motors. This can be helpful when replacing a motor with a different frame size. See Chapter 2: Mounting and Initial Startup for complete motor dimensions.

Motor Mounting Feet		
Frame Size *	Double Punched	Punched for Additional Frame Size
56 **	Yes	56H
143T	No	–
145T	Yes	143T
182T ***	Yes	184T
184T	Yes	182T
213T	No	–
215T	Yes	213T
254T	No	–
256T	Yes	254T
284T	No	–
286T	Yes	284T
324T	No	–
326T	Yes	324T
364T	No	–
365T	Yes	364T
405T	Yes	404T
444T	No	–
445T	Yes	444T
445/7T	Yes	445T
449T	No	–

* TC-frame motors have the same mounting foot punching as the comparable T-frame motors.
 ** MTSS-xxx-xxxxR round-body motors do not have mounting feet.
 *** MTF-002-1C18-182 only

RADIAL OVERHUNG LOAD

The table below lists the maximum overhung radial load for MTCP, MTCP2, and MTC cast-iron motors. Values listed are in pounds (lbs) at the center of the N-W dimension.

Shaft Loading for AC Induction Horizontal Motors with Ball Bearings				
Frame Size	Synchronous Speed			
	3600	1800	1200	900
143T	106	154	179	192
145T	109	154	176	196
182T	180	227	260	287
184T	180	227	260	289
213T	230	300	350	380
215T	230	300	350	380
254T	470	593	703	774
256T	470	589	705	776
284T	570	735	838	929
286T	570	735	838	929
324T	660	860	990	1100
326T	660	850	980	1090
364T	820	1080	1240	1390
365T	820	1080	1240	1370
404T	-	1270	1450	1600
405T	-	1290	1480	1630
444T	-	1560	1760	1970
445T	-	1520	1760	1970
447T	-	1450	1660	1880
449T	-	1490	1660	1880

Notes:

- All belt loads are considered to act in vertically downward direction.
- Overhung loads include belt tension and weight of sheave.
- For load at end of the shaft, subtract 15%.
- Radial overhung load limits based on bearing L-10 life of 26,280 hours.
- Overhung load limits do not include any effect of unbalanced magnetic pull.
- In applications involving over hung load, drive end, bearing life, may be increased by replacing ball bearings with equivalent roller bearings. Consult your EASA authorized motor shop for details.

F1 AND F2 MOUNTING

F1 and F2 mounting refers to the location of the junction box on an AC motor. Several models of IronHorse® motors can be converted from F1 to F2 mounting.

F1 to F2 Mounting Convertibility	
Frame Size *	Ability to be Converted
56	No (F1 only)
143T	MTC Motors: Yes (F1, convertible to F2) MTCP(2) Motors: Yes (F1, convertible to F2) MTF Motors: No (F1 only) MTF2 Motors: No (F1 only) MTDP Motors: No (F1 only)
145T	
182T	
184T**	
213T	
215T	
254T	
256T	
284T	
286T	
324T	
326T	
364T	
365T	MTC Motors: No (F1 only) MTCP(2) Motors: No (F1 only)
405T	
444T	MTC Motors: Yes (F1, convertible to F2) MTCP(2) Motors: Yes (F1, convertible to F2)
445T	
445/7T	
449T	No (F1 only)

* TC-frame motors have the same convertibility as the comparable T-frame motors.
 ** The MTCP2 184T frame motor is F1 only.

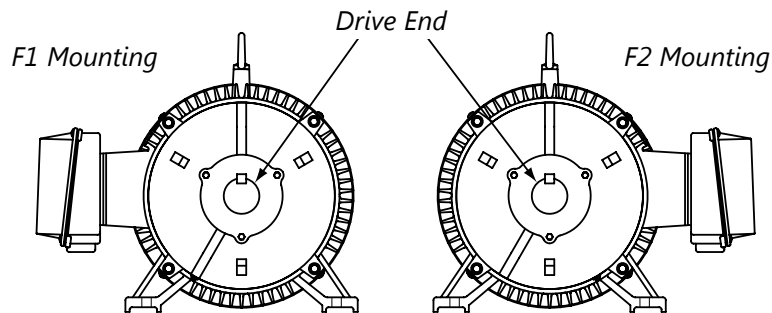

TO MINIMIZE THE POTENTIAL OF DAMAGE TO ANY INTERNAL COMPONENT, USE CAUTION WHEN PULLING THE ROTOR FROM THE FRAME WHEN CONVERTING AN IRONHORSE® MOTOR FROM F1 TO F2 MOUNTING. AUTHORIZED EASA SERVICE CENTERS ARE EQUIPPED WITH THE NECESSARY EQUIPMENT TO QUICKLY AND INEXPENSIVELY CONVERT MOTOR MOUNTING. VISIT THE EASA WEBSITE AT WWW.EASA.COM TO FIND THE NEAREST AUTHORIZED SERVICE CENTER. CONVERSION FROM F1 TO F2 MOUNTING MUST BE PERFORMED BY AN EASA MOTOR SHOP IN ORDER TO MAINTAIN THE MOTOR WARRANTY.

JUNCTION BOX DIMENSIONS

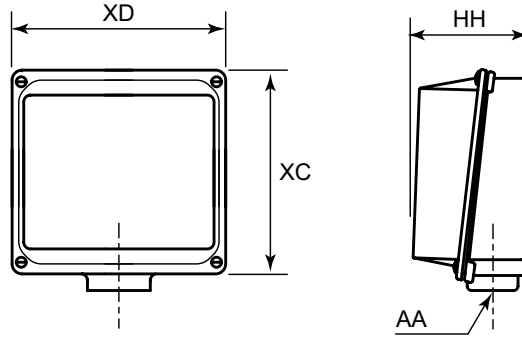

Junction Box Dimensions (in)																			
Frame Size *	XD (Width)			XC (Height)			HH (Depth)			AA (Conduit Hole) (NPT)									
	MTF2	MTR2 MTRP	MTCP2	MTF2	MTR2 MTRP	MTCP2	MTF2	MTR2 MTRP	MTCP2										
56	n/a	3.2	n/a	n/a	3.7	n/a	n/a	1.6	n/a	1/2									
143T		4.1	4.1		4.5	4.5		2.3	2.4	3/4									
145T																			
182T	7.8	4.6	4.6	7.8	5.0	5.0	2.7	2.6	2.8	1									
184T																			
213T	n/a	6.3	6.3	n/a	7.2	7.3	n/a	3.3	3.7	1-1/2									
215T																			
254T																			
256T																			
284T																			
286T																			
324T																			
326T											9	9.0	n/a	10.6	10.6	n/a	5.3	5.7	2
364T																			3
365T											11.3	11.3	n/a	11.7	11.8	n/a	7.1	7.2	7.2
405T	9.8	9.8	11.8	7.2															
444T																			
445T																			
445/7T																			
449T	11.3	11.3	12.4	7.3															

* TC-frame motors have the same junction boxes as the comparable T-frame motors.

MINIMUM SHEAVE DIAMETERS

The table below illustrates the minimum practical V-belt sheave diameter that can be used with each IronHorse® motor frame size.

Minimum Sheave Diameters		
Frame Size (1)	V-Belt Sheave (2)	
	Conventional A, B, C, D and E (3)	Narrow 3V, 5V and 8V (4)
	Minimum Pitch Diameter (in)	Minimum Outside Diameter (in)
143T	2.2	2.2
145T	2.4	2.4
182T	2.4	2.4
184T	3.0	3.0
213T	3.0	3.0
215T	3.8	3.8
254T	4.4	4.4
256T	4.6	4.4
284T	5.0	4.4
286T	5.4	5.2
324T	6.0	6.0
326T	6.8	6.8
364T	7.4	7.4
365T	9.0	8.6
405T	10.0	8.6
444T	11.0	9.5
445T	–	10.5
449T	–	13.2

1) TC-frame motors have the same minimum sheave diameters as the comparable T-frame motors.
 2) Sheave dimensions are based on the following:
 a) Motor nameplate horsepower and speed.
 b) Belt service factor of 1.6 with belts tightened to the belt manufacturers recommendations.
 c) Speed reduction of 5:1.
 d) Mounting of sheave on motor according to sheave manufacturers instructions.
 e) Center-to-center distance between sheaves approximately equal to the diameter of the larger sheave.
 f) Calculations covered by the standards listed in notes 3 & 4 below.
 3) As covered by IP-20; Specifications for Drives Using Classical V-Belts and Sheaves. Go to www.mpta.org and www.rma.org for details.
 4) As covered by IP-22; Specifications for Drives Using Narrow V-Belts and Sheaves. Go to www.mpta.org and www.rma.org for details.

DECIBEL LEVELS

The decibel (sound) level of an IronHorse® motor should be measured after initial startup, after 30 days, and after six months of use. Decibel levels should remain fairly consistent and can be an indication of misalignment and premature bearing wear. If the measured decibel level for your IronHorse model exceeds the value listed below by more than 10%, contact AutomationDirect or a local motor service technician found at www.easa.com.

Average T-Frame Decibel Levels								
Frame Size *	HP	Noise Level: Lw dB(A) @ 1m						
		MTF	MTCP2			MTDP		MTF2
			1200 RPM	1800 RPM	3600 RPM	1800	3600	
143T	1	-	-	60	-	50	-	-
	1-1/2	-	-	-	62	-	-	-
145T	1	-	58	-	-	-	-	-
	1-1/2	-	-	62	-	50	-	-
	2	-	-	62	62	51	-	-
	3	-	-	-	-	-	56	-
182T	1-1/2	-	62	-	-	-	-	-
	2	76.0	-	-	-	-	-	54
	3	-	-	63	64	52	-	-
	5	-	-	-	-	-	67	-
184T	2	-	62	-	-	-	-	-
	3	-	-	-	-	-	-	56
	5	76.0	-	63	64	53	-	58
	7.5	-	-	-	-	-	67	-
213T	3	-	64	-	-	-	-	56
	7-1/2	-	-	63	65	55	-	-
215T	5	-	64	-	-	-	-	-
	7-1/2	-	-	-	-	-	-	62
	10	-	-	64	67	56	-	65
254T	7-1/2	-	66	-	-	-	-	-
	15	-	-	67	70	60	-	-
256T	10	-	68	-	-	-	-	-
	20	-	-	68	72	63	-	-
284T	15	-	70	-	-	-	-	-
	25	-	-	70	-	66	-	-
286T	20	-	70	-	-	-	-	-
	30	-	-	70	-	67	-	-
324T	40	-	-	71	-	69	-	-
326T	50	-	-	72	-	70	-	-
364T	60	-	-	73	-	-	-	-
365T	75	-	-	74	-	-	-	-
405T	100	-	-	74	-	-	-	-
444T	125	-	-	76	-	-	-	-
445T	150	-	-	77	-	-	-	-
445/7T	200	-	-	78	-	-	-	-
449T	250	-	-	93	-	-	-	-
	300	-	-	93	-	-	-	-

* TC-frame motors have the same sound ratings as the comparable T-frame motors.

(CONTINUED ON NEXT PAGE)

Average 56C Frame Decibel Levels									
MTR2						MTRP			
Noise Level: Lw dB(A) @ 1m						Noise Level: Lw dB(A) @ 1m			
Frame Size	HP	1800 RPM		3600 RPM		Frame Size	HP	1800 RPM	3600 RPM
		1Ø	3Ø	1Ø	3Ø			3Ø	3Ø
56C	1/3	70.0	70.0	80.0	80.0	56CH	1/3	-	-
	1/2								
	3/4								
	1			80.0	80.0				
	1-1/2			85.0	85.0				
	2			74.0	85.0		85.0		
	3	-	-	-	88.0				
							70.0	80.0	
								85.0	
								85.0	
								88.0	

* TC-frame motors have the same sound ratings as the comparable T-frame motors.

SHIPPING CRATE DIMENSIONS

Nominal Shipping Crate Dimensions								
Frame Size *	HP	Width x Depth x Height (in)						
		MTF	MTR2	MTRP	MTCP2	MTDP	MTF2	
56C	1/3	-	13.5 x 11 x 11	-	-	-	-	
	1/2							
	3/4							
	1							
	1-1/2							
	2							
56HC	1	-	-	14 x 11 x 11.5	-	-	-	
	1-1/2		14.5 x 11 x 11	15 x 11 x 11.5 (1800 RPM) 14 x 11 x 15 (3600 RPM)				
	2		16 x 11 x 11	15.5 x 11 x 11.5 (1800 RPM) 14 x 11 x 15.5 (3600 RPM)				
	3			15 x 11 x 11.5				
143T	1	-	-	-	-	-	-	
143T	1-1/2							
145T	1-1/2							
145T	2							
182T	1-1/2							
182T	2							18 x 14 x 14
182T	3							
184T	2							
184T	3							19 x 14 x 14
184T	5							21.5 x 14 x 14
213T	3							
213T	7-1/2							
215T	5							
215T	10							
254T	1-1/2							
254T	15							
256T	10							
256T	20							
284T	15							
284T	25							
286T	20							
286T	30							
324T	40							
326T	50							
364T	60							
365T	75							
405T	100							
444T	125							
445T	150							
445/7T	200							
449T	250							
	300							
		18.9 x 12.99 x 10.63	14.4 x 11.4 x 11	-	-	-		
		21.46 x 15.55 x 12.99	-	-	-	-		
		21.46 x 15.55 x 12.99	18.1 x 13 x 11	20.685 x 14.972 x 15.169	-	-		
		21.46 x 15.55 x 12.99	-	-	-	-		
		26.38 x 17.91 x 14.96	19.3 x 14.6 x 14.6	23.443 x 17.73 x 16.942	-	-		
		32.68 x 22.05 x 19.09	26.1 x 20.1 x 17.7	-	-	-		
		34.65 x 23.23 x 21.46	27.4 x 21.9 x 20.3	-	-	-		
		34.65 x 23.23 x 21.46						
		37.80 x 26.77 x 22.83	30.7 x 22.8 x 22.2	-	-	-		
		41.73 x 28.74 x 25.98	-	-	-	-		
		43.70 x 34.25 x 29.13	-	-	-	-		
		49.61 x 35.83 x 32.68	-	-	-	-		
		53.54 x 35.83 x 32.68	-	-	-	-		
		62.99 x 36.22 x 33.86	-	-	-	-		

* TC-frame motors ship in the same crates as the comparable T-frame motors.

Shipping weights are listed in the Motor Specifications tables in "Chapter 1: Getting Started."

PERFORMANCE CURVES FOR MTF2 MOTORS

MTF2-002-1B18-182

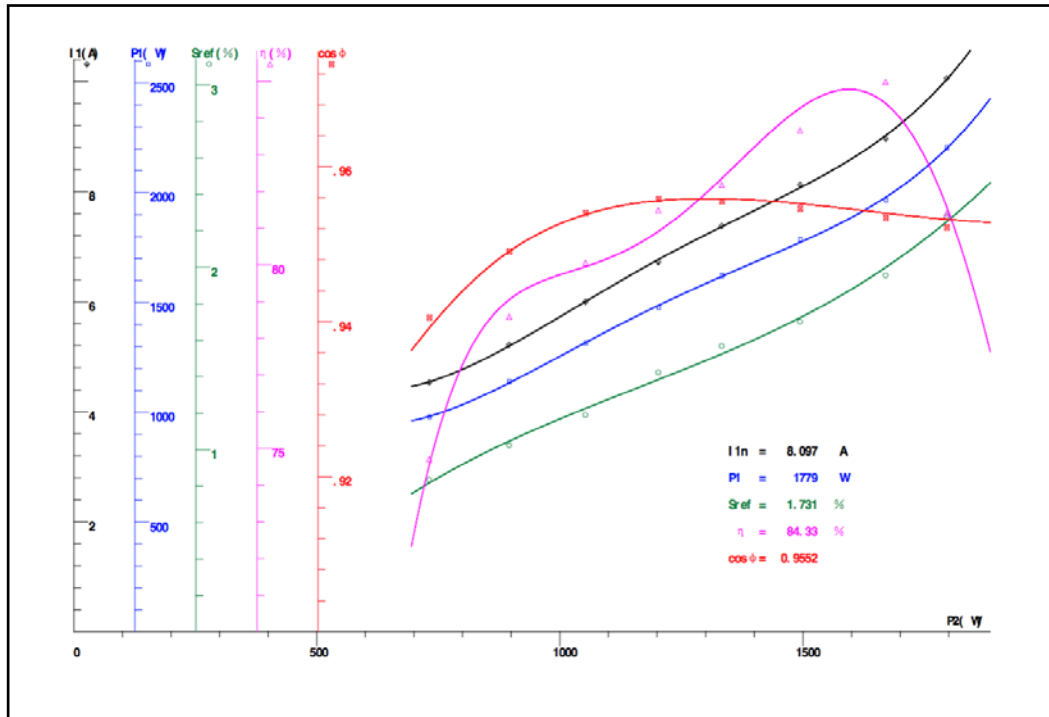

Tc (N.m.)	s (%)	sj (%)	P2 (W)	P1j (W)	I 1j (A)	η (%)	η j (%)	cos Φ	cosj Φ
9.749	2.278	2.250	1796	2201	10.04	81.40	81.58	0.9522	0.9532
9.037	1.956	1.999	1670	1979	9.018	84.99	84.40	0.9534	0.9540
8.064	1.700	1.732	1494	1773	8.07	83.66	84.27	0.9546	0.9552
7.184	1.567	1.524	1333	1618	7.362	82.18	82.35	0.9556	0.9559
6.473	1.422	1.383	1203	1487	6.763	81.49	80.91	0.9558	0.9556
5.652	1.189	1.226	1053	1317	6.002	80.05	79.95	0.9540	0.9538
4.802	1.022	1.046	895.9	1133	5.192	78.59	79.05	0.9491	0.9490
3.913	0.8333	0.8162	731.4	981.3	4.543	74.70	74.54	0.9405	0.9392

I 1 = 8.097 A
 n = 1768.8 r/min
 P1n = 1779 W
 η = 84.33%
 Sn = 1.731%
 cos Φ = 0.9552

Rated Power	P1 (W)	I 1 (A)	S (%)	n (speed)	P2 (W)	T (N.m.)	η (%)	cos Φ
150%	4478	20.42	3.725	1732.9	2250	12.4	50.25	0.9534
125%	2398	10.94	2.437	1756.1	1875	10.2	78.17	0.9529
100%	1779	8.097	1.731	1768.8	1500	8.099	84.33	0.9552
75%	1401	6.377	1.302	1776.8	1125	6.048	80.32	0.9550
50%	994.1	4.595	0.8450	1784.8	750	4.013	75.44	0.9406
25%	1238	5.875	0.0541	1799.0	375	1.991	30.29	0.9163

MTF2-003-1B18

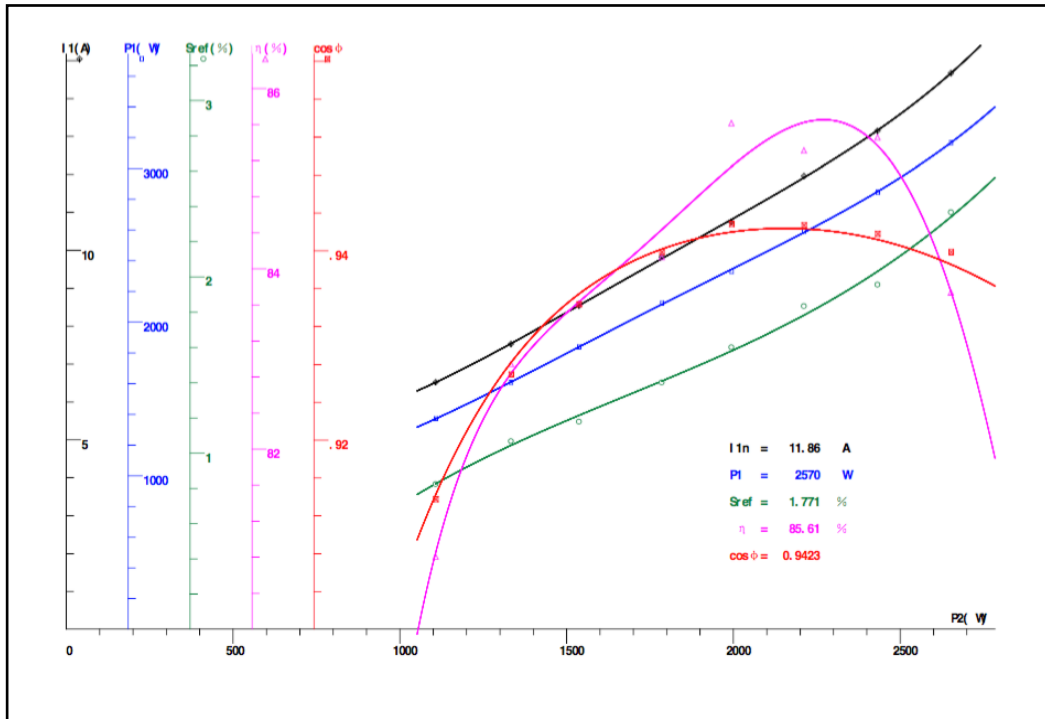

Tc (N.m.)	s (%)	sj (%)	P2 (W)	P1j (W)	I 1j (A)	η (%)	η j (%)	cos Φ	cosj Φ
14.41	2.367	2.340	2652	3167	14.67	83.74	83.75	0.9398	0.9386
13.16	1.956	2.031	2432	2849	13.16	85.46	85.37	0.9418	0.9412
11.95	1.833	1.782	2211	2583	11.92	85.31	85.62	0.9427	0.9423
10.75	1.600	1.579	1994	2342	10.81	85.61	85.13	0.9428	0.9420
9.606	1.400	1.408	1785	2114	9.778	84.13	84.43	0.9399	0.9402
8.251	1.178	1.213	1537	1838	8.541	83.62	83.63	0.9343	0.9354
7.148	1.067	1.043	1333	1609	7.537	82.94	82.84	0.9269	0.9282
5.922	0.8222	0.8246	1107	1369	6.513	80.81	80.84	0.9137	0.9142

$I 1 = 11.86 \text{ A}$ $P1n = 2570 \text{ W}$ $S_n = 1.771\%$
 $n = 1768.1 \text{ r/min}$ $\eta = 85.61\%$ $\cos \Phi = 0.9423$

Rated Power	P1 (W)	I 1 (A)	S (%)	n (speed)	P2 (W)	T (N.m.)	η (%)	cos Φ
150%	4854	22.85	3.781	1731.9	3300	18.20	67.98	0.9235
125%	3336	15.48	2.503	1755.0	2750	14.96	82.45	0.9369
100%	2570	11.86	1.771	1768.1	2200	11.88	85.61	0.9423
75%	1965	9.106	1.303	1776.6	1650	8.870	83.99	0.9380
50%	1362	6.484	0.8171	1785.3	1100	5.884	80.74	0.9136
25%	1042	5.388	0.0320	1799.4	550	2.919	52.80	0.8404

MTF2-005-1B18

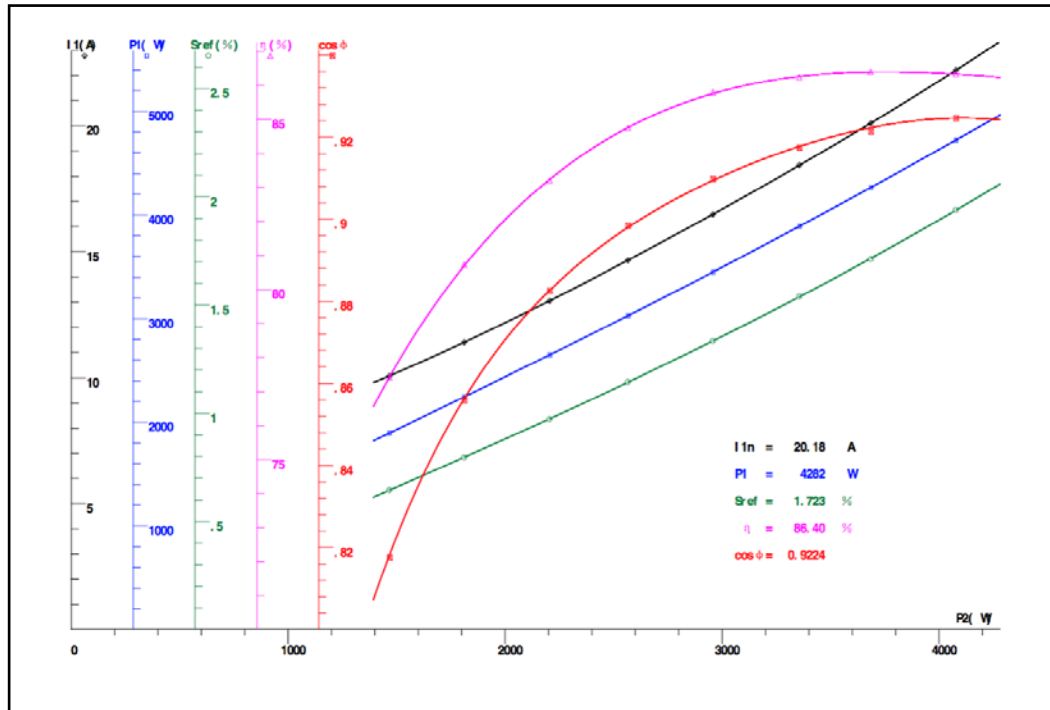

I1n = 20.18 A
 P1 = 4282 W
 Sref = 1.723 %
 η = 86.40 %
 cos φ = 0.9224

Tc (N.m.)	s (%)	sj (%)	P2 (W)	P1j (W)	I1j (A)	η (%)	ηj (%)	cos Φ	cosj Φ
22.06	1.939	1.938	4078	4723	22.21	86.34	86.34	0.9246	0.9246
19.89	1.711	1.714	3685	4265	20.11	86.41	86.40	0.9214	0.9223
18.08	1.539	1.537	3356	3890	18.43	86.25	86.27	0.9174	0.9177
15.9	1.333	1.333	2957	3448	16.49	85.80	85.76	0.9098	0.9094
13.77	1.144	1.143	2566	3028	14.66	84.75	84.76	0.8984	0.8980
11.81	0.9722	0.9735	2205	2649	13.05	83.20	83.23	0.8825	0.8826
9.688	0.7944	0.7956	1811	2245	11.40	80.73	80.69	0.8558	0.8562
7.833	0.6444	0.6436	1467	1895	10.07	77.41	77.42	0.8175	0.8180

I1 = 20.18 A P1n = 4282 W Sn = 1.723%
 n = 1769.0 r/min η = 86.40% cos Φ = 0.9224

Rated Power	P1 (W)	I1 (A)	S (%)	n (speed)	P2 (W)	T (N.m.)	η (%)	cos Φ
150%	6483	31.90	2.917	1747.5	5550	30.33	85.60	0.8837
125%	5376	25.40	2.273	1759.1	4625	25.11	86.04	0.9203
100%	4282	20.18	1.723	1769.0	3700	19.97	86.40	0.9224
75%	3251	15.62	1.243	1777.6	2775	14.91	85.37	0.9046
50%	2284	11.56	0.8128	1785.4	1850	9.896	80.99	0.8595
25%	1341	8.285	0.4092	1792.6	925	4.928	68.97	0.7038

MTF2-7P5-1B18-215

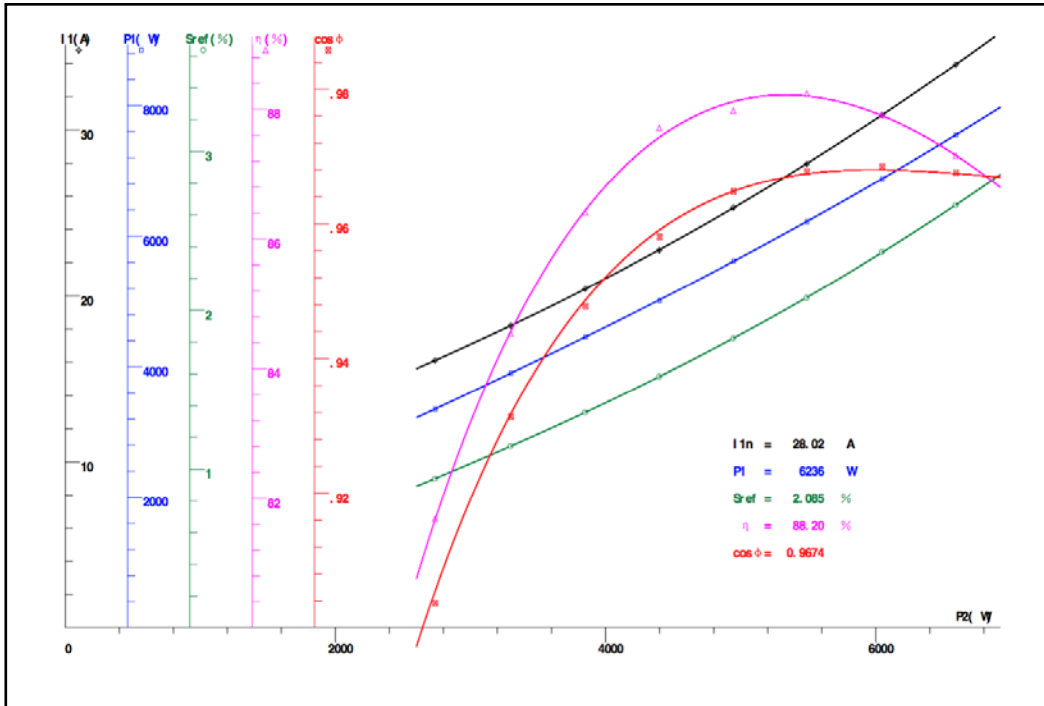

Tc (N.m.)	s (%)	sj (%)	P2 (W)	P1j (W)	I 1j (A)	η (%)	η j (%)	cos Φ	cosj Φ
35.93	2.661	2.662	6593	7552	33.94	87.28	87.29	0.9676	0.9675
32.85	2.367	2.363	6046	6878	30.89	87.91	87.90	0.9685	0.9680
29.74	2.078	2.080	5490	6224	27.97	88.24	88.20	0.9677	0.9674
26.72	1.822	1.823	4945	5612	25.29	87.98	88.12	0.9648	0.9648
23.71	1.583	1.582	4399	5023	22.77	87.71	87.57	0.9580	0.9590
20.70	1.356	1.356	3849	4453	20.41	86.40	86.44	0.9477	0.8486
17.70	1.144	1.143	3299	3901	18.20	84.54	84.57	0.9313	0.9317
14.66	0.9389	0.9394	2738	3353	16.10	81.68	81.66	0.9036	0.9054

I 1 = 28.02 A P1n = 6236 W Sn = 2.085%
 n = 1762.5 r/min η = 88.20% cos Φ = 0.9674

Rated Power	P1 (W)	I 1 (A)	S (%)	n (speed)	P2 (W)	T (N.m.)	η (%)	cos Φ
150%	9813	44.19	3.719	1733.1	8250	45.46	84.07	0.9655
125%	7914	35.58	2.826	1749.1	6875	37.54	86.87	0.9670
100%	6236	28.02	2.085	1762.5	5500	29.80	88.20	0.9674
75%	4737	21.58	1.468	1773.6	4125	22.21	87.09	0.9545
50%	3364	16.14	0.9437	1783.0	2750	14.73	81.74	0.9061
25%	2056	11.48	0.4838	1791.3	1375	7.331	66.89	0.7784

MTF2-010-1B18

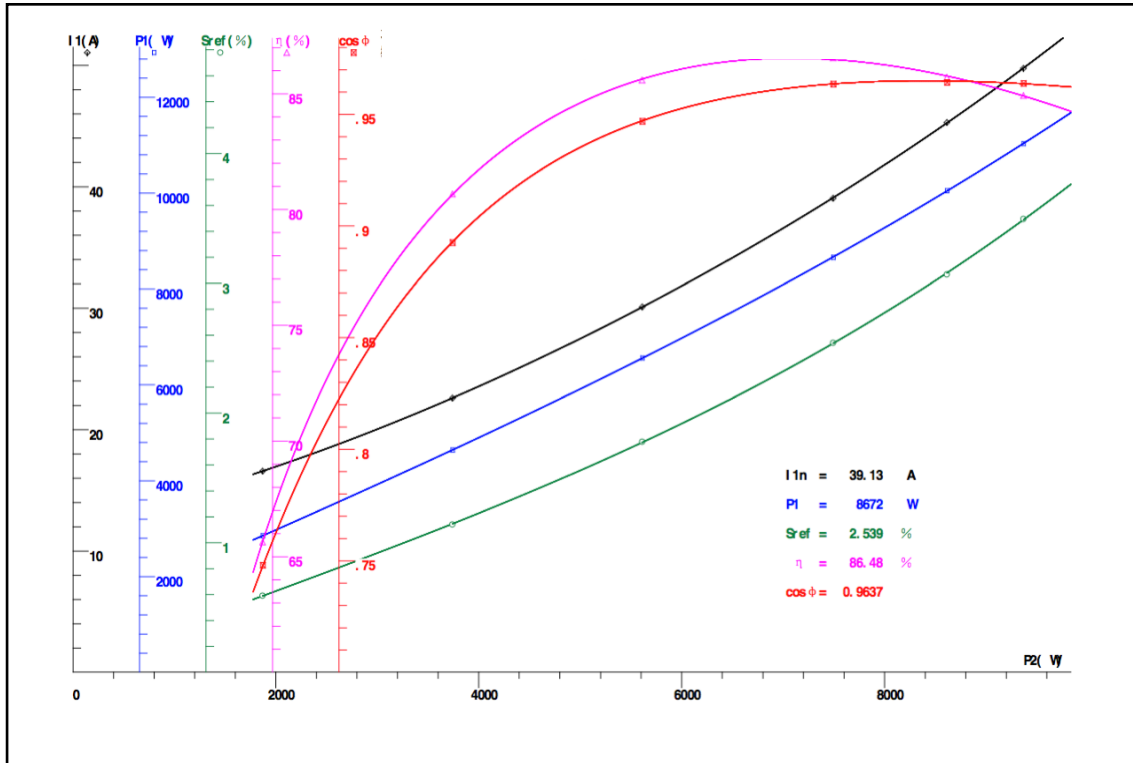

Tc (N.m.)	s (%)	sj (%)	P2 (W)	P1j (W)	I 1j (A)	η (%)	η j (%)	cos Φ	cosj Φ
51.50	3.494	3.488	9368	11034	49.78	84.93	84.91	0.9638	0.9637
47.14	3.067	3.078	8613	10042	45.25	85.71	85.77	0.9643	0.9650
40.78	2.539	2.536	7492	8663	39.08	86.55	86.48	0.9636	0.9637
30.30	1.778	1.772	5610	6551	30.07	85.59	85.64	0.9468	0.9471
20.07	1.139	1.144	3741	4639	22.59	80.67	80.64	0.8925	0.8928
9.975	0.5889	0.5873	1869	2848	16.57	65.63	65.63	0.7479	0.7473

$I_1 = 39.13 \text{ A}$ $P_{1n} = 8672 \text{ W}$ $S_n = 2.539\%$
 $n = 1754.3 \text{ r/min}$ $\eta = 86.48\%$ $\cos \Phi = 0.9637$

Rated Power	P1 (W)	I 1 (A)	S (%)	n (speed)	P2 (W)	T (N.m.)	η (%)	cos Φ
150%	13771	62.67	4.695	1715.5	11250	62.63	81.70	0.9553
125%	11042	49.82	3.492	1737.1	9375	51.54	84.90	0.9637
100%	8672	39.13	2.539	1754.3	7500	40.83	86.48	0.9637
75%	6567	30.14	1.777	1768.0	5625	30.38	85.66	0.9473
50%	4648	22.62	1.147	1779.3	3750	20.13	80.68	0.8932
25%	2853	16.58	0.5891	1789.4	1875	10.01	65.71	0.7480

PERFORMANCE CURVES FOR MTR2 MOTORS

MTR2-P33-1AB18

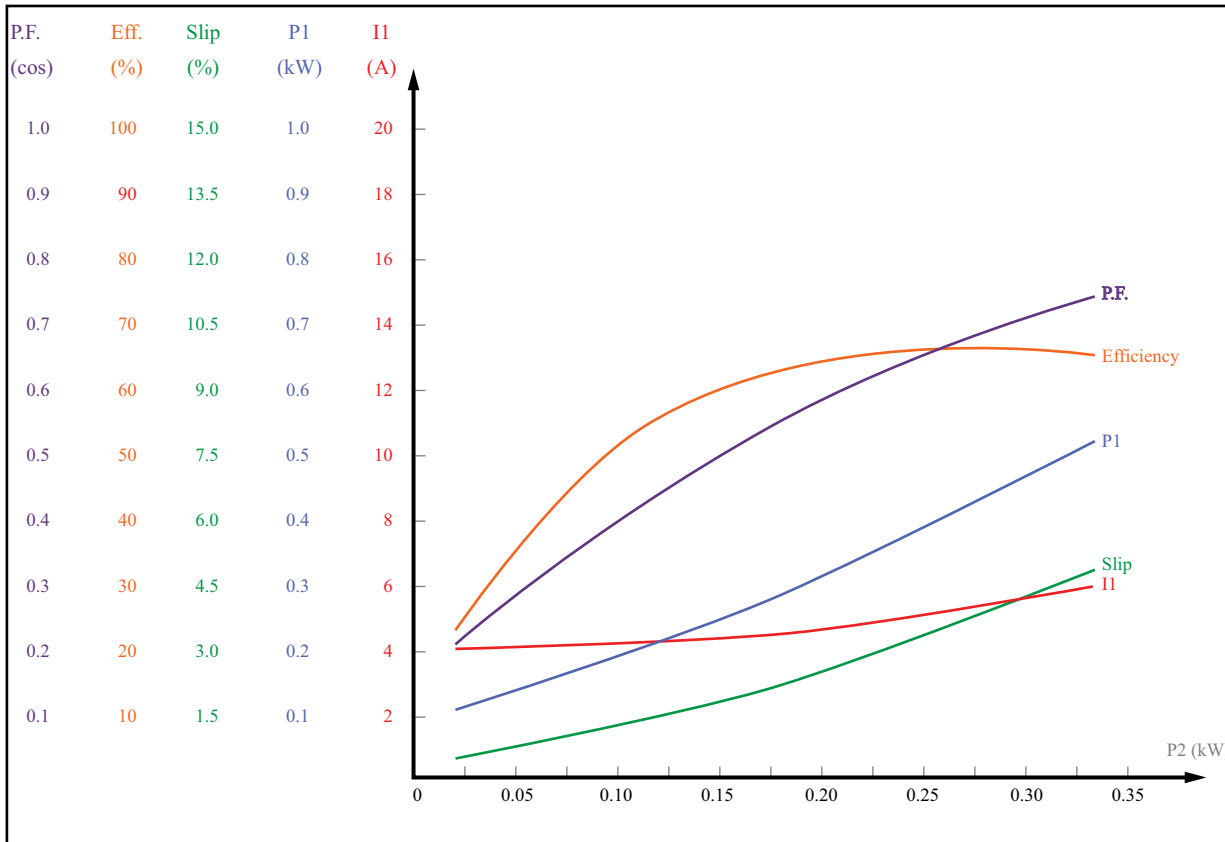

Performance Data - MTR2-P33-1AB18							
P2 (kW)	U (V)	I1 (A)	P1 (kW)	Torque (N·m)	Speed (RPM)	EFF (%)	P.F. (cos)
0.0672	116.0	4.10	0.1574	0.36	1783	42.72	0.33
0.1170	115.8	4.23	0.2123	0.63	1773	55.12	0.43
0.1371	115.7	4.32	0.2362	0.74	1769	58.06	0.47
0.1716	115.6	4.49	0.2761	0.93	1761	62.16	0.53
0.2057	115.5	4.69	0.3169	1.12	1753	64.92	0.59
0.2429	115.3	5.01	0.3696	1.33	1743	65.73	0.64
0.2865	115.1	5.42	0.4322	1.58	1730	66.28	0.69
0.3172	114.9	5.78	0.4808	1.76	1719	65.97	0.72

Load Performance Data - MTR2-P33-1AB18						
Load (%)	Current (A)	Input (kW)	Slip (%)	EFF (%)	P.F. (cos)	Output (kW)
25	4.10	0.1540	0.89	40.60	0.327	0.06
50	4.26	0.2204	1.53	56.73	0.450	0.13
75	4.58	0.2956	2.32	63.43	0.561	0.19
100	5.07	0.3796	3.23	65.85	0.651	0.25
125	5.72	0.4725	4.28	66.13	0.718	0.31

MTR2-P33-1AB36

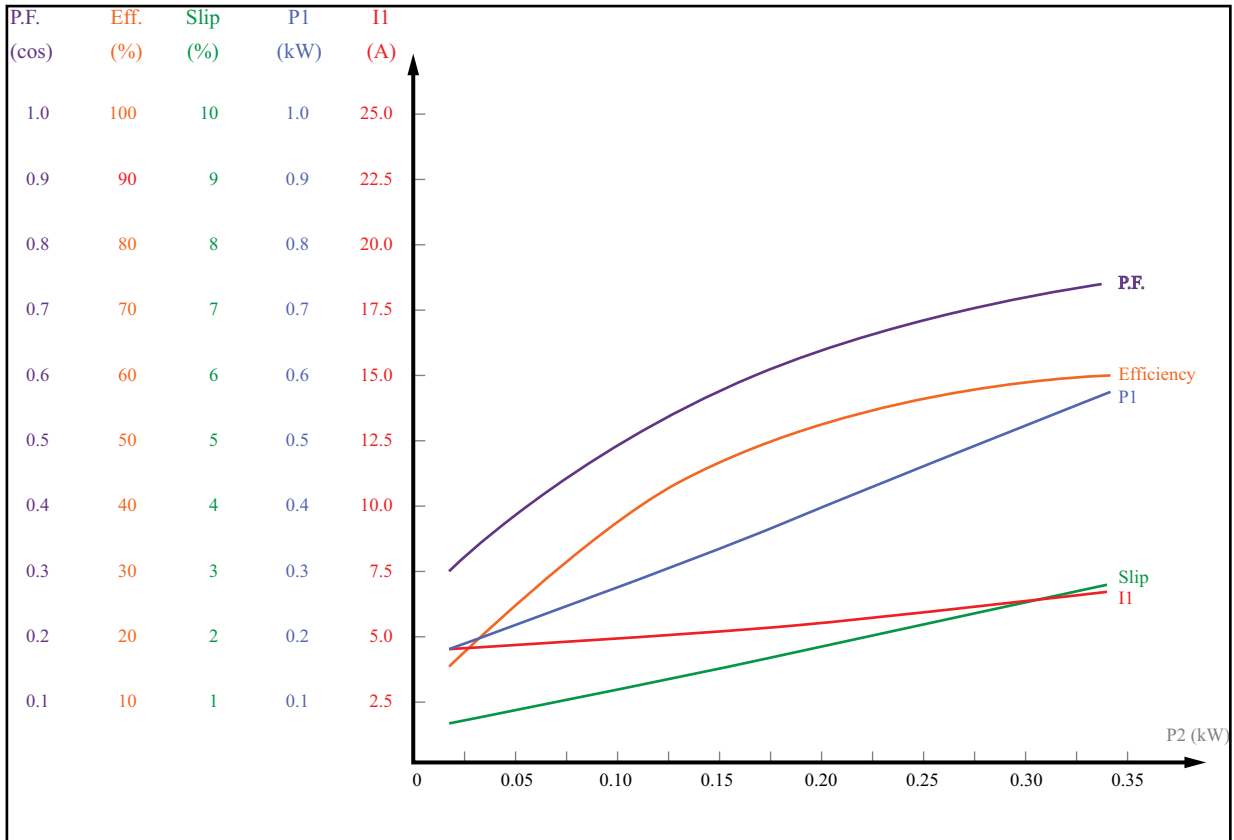

Performance Data - MTR2-P33-1AB36							
P2 (kW)	U (V)	I1 (A)	P1 (kW)	Torque (N·m)	Speed (RPM)	EFF (%)	P.F. (cos)
0.0858	115.2	4.67	0.2505	0.23	3564.3	34.27	0.47
0.0970	115.2	4.73	0.2665	0.26	3561.3	36.38	0.49
0.1302	115.1	4.90	0.3056	0.35	3554.1	42.63	0.54
0.1744	115.0	5.16	0.3576	0.47	3543.7	48.76	0.60
0.2073	115.0	5.39	0.3967	0.56	3535.6	52.26	0.64
0.2437	114.9	5.66	0.4387	0.66	3526.8	55.55	0.67
0.2763	114.8	5.93	0.4798	0.75	3519.2	57.59	0.70
0.3195	115.7	6.37	0.5389	0.87	3508.2	59.29	0.73

Load Performance Data - MTR2-P33-1AB36						
Load (%)	Current (A)	Input (kW)	Slip (%)	EFF (%)	P.F. (cos)	Output (kW)
25	4.58	0.2264	0.86	27.60	0.430	0.06
50	4.87	0.2979	1.26	41.96	0.532	0.13
75	5.25	0.3720	1.67	50.40	0.616	0.19
100	5.72	0.4487	2.09	55.71	0.682	0.25
125	6.29	0.5280	2.53	59.19	0.730	0.31

MTR2-P33-3BD18

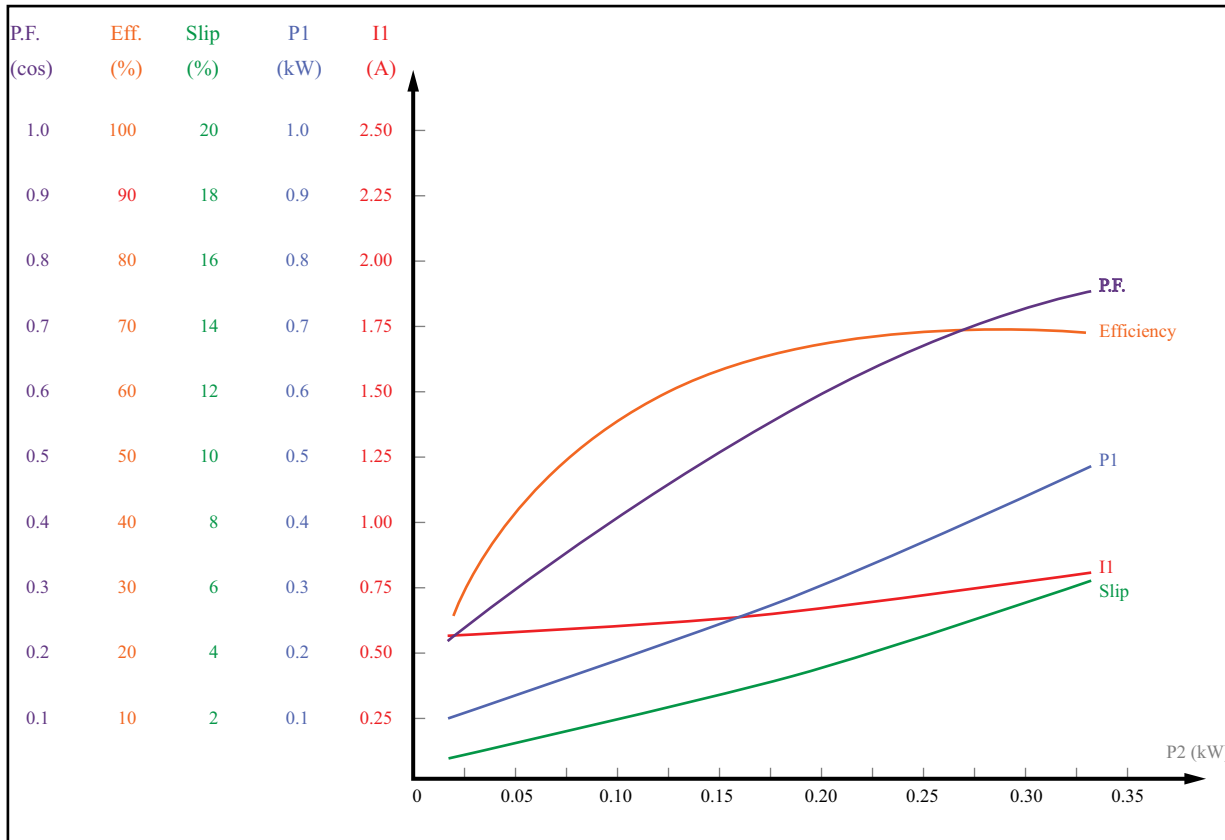

Performance Data - MTR2-P33-3BD18							
P2 (kW)	U (V)	I1 (A)	P1 (kW)	Torque (N·m)	Speed (RPM)	EFF (%)	P.F. (cos)
0.0582	460.9	0.56	0.1350	0.30	1780	43.15	0.31
0.1112	460.8	0.58	0.1940	0.61	1764	57.30	0.42
0.1320	460.8	0.59	0.5180	0.74	1758	60.56	0.47
0.1591	460.8	0.61	0.2500	0.90	1749	63.63	0.52
0.2072	460.7	0.65	0.3090	1.17	1734	67.05	0.60
0.2384	460.7	0.68	0.3490	1.35	1723	68.32	0.65
0.2682	460.7	0.71	0.3890	1.54	1712	68.95	0.69
0.3075	460.6	0.76	0.4440	1.78	1696	69.25	0.73

Load Performance Data - MTR2-P33-3BD18						
Load (%)	Current (A)	Input (kW)	Slip (%)	EFF (%)	P.F. (cos)	Output (kW)
25	0.56	0.1400	1.28	44.66	0.315	0.06
50	0.58	0.2095	2.19	59.67	0.450	0.13
75	0.63	0.2845	3.24	65.91	0.569	0.19
100	0.69	0.3648	4.42	68.62	0.664	0.25
125	0.77	0.4506	5.74	69.35	0.735	0.31

MTR2-P33-3BD36

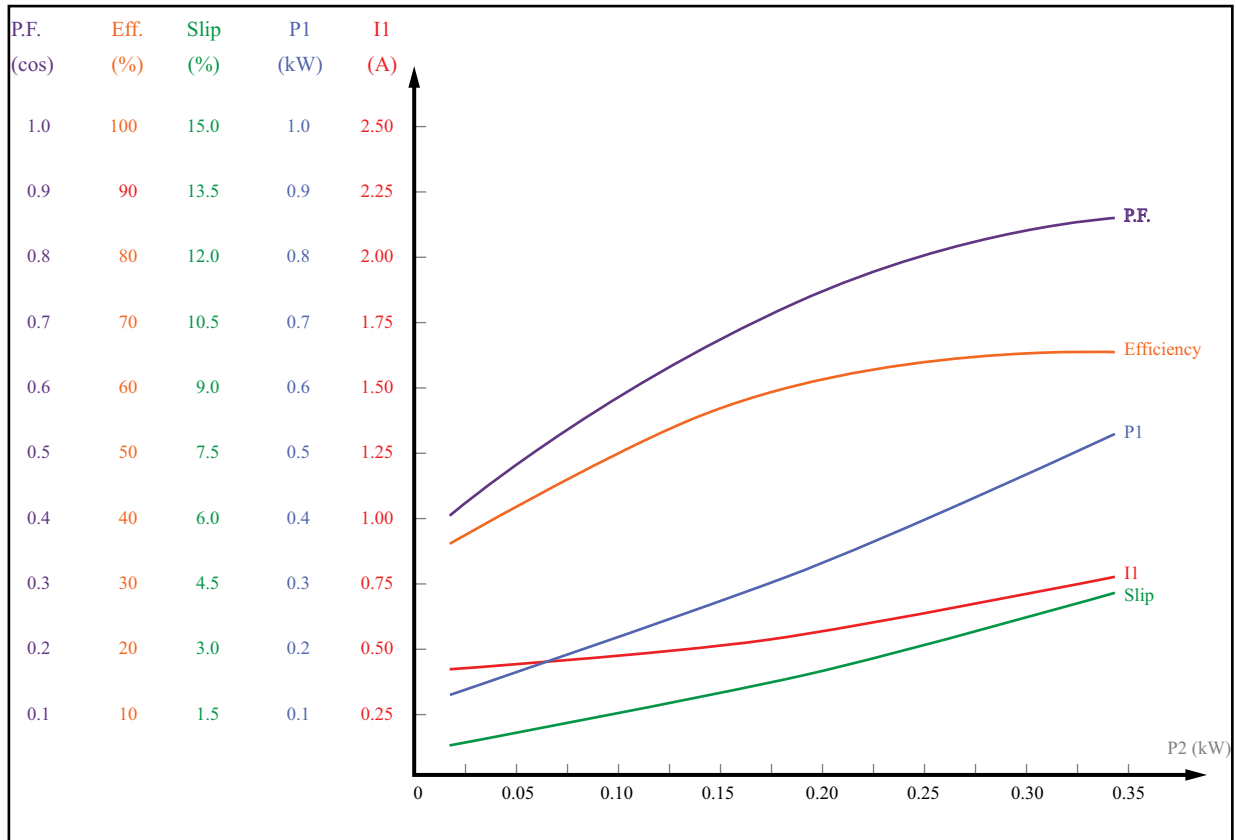

Performance Data - MTR2-P33-3BD36							
P2 (kW)	U (V)	I1 (A)	P1 (kW)	Torque (N·m)	Speed (RPM)	EFF (%)	P.F. (cos)
0.1375	460.6	0.49	0.2530	0.34	3536	54.36	0.65
0.1452	460.6	0.50	0.2620	0.35	3534	55.43	0.66
0.1551	460.6	0.51	0.2740	0.38	3530	56.61	0.68
0.1790	460.5	0.53	0.3030	0.46	3520	59.08	0.72
0.2017	460.5	0.56	0.3310	0.52	3512	60.93	0.75
0.2499	460.5	0.62	0.3930	0.66	3491	63.60	0.80
0.2871	460.4	0.67	0.4430	0.78	3474	64.81	0.83
0.3180	460.4	0.72	0.4860	0.87	3459	65.44	0.85

Load Performance Data - MTR2-P33-3BD36						
Load (%)	Current (A)	Input (kW)	Slip (%)	EFF (%)	P.F. (cos)	Output (kW)
25	0.43	0.1687	1.07	37.05	0.495	0.06
50	0.48	0.2385	1.61	52.42	0.627	0.13
75	0.54	0.3133	2.24	59.85	0.726	0.19
100	0.62	0.3932	2.94	63.58	0.797	0.25
125	0.71	0.4782	3.74	65.35	0.844	0.31

MTR2-P50-1AB18

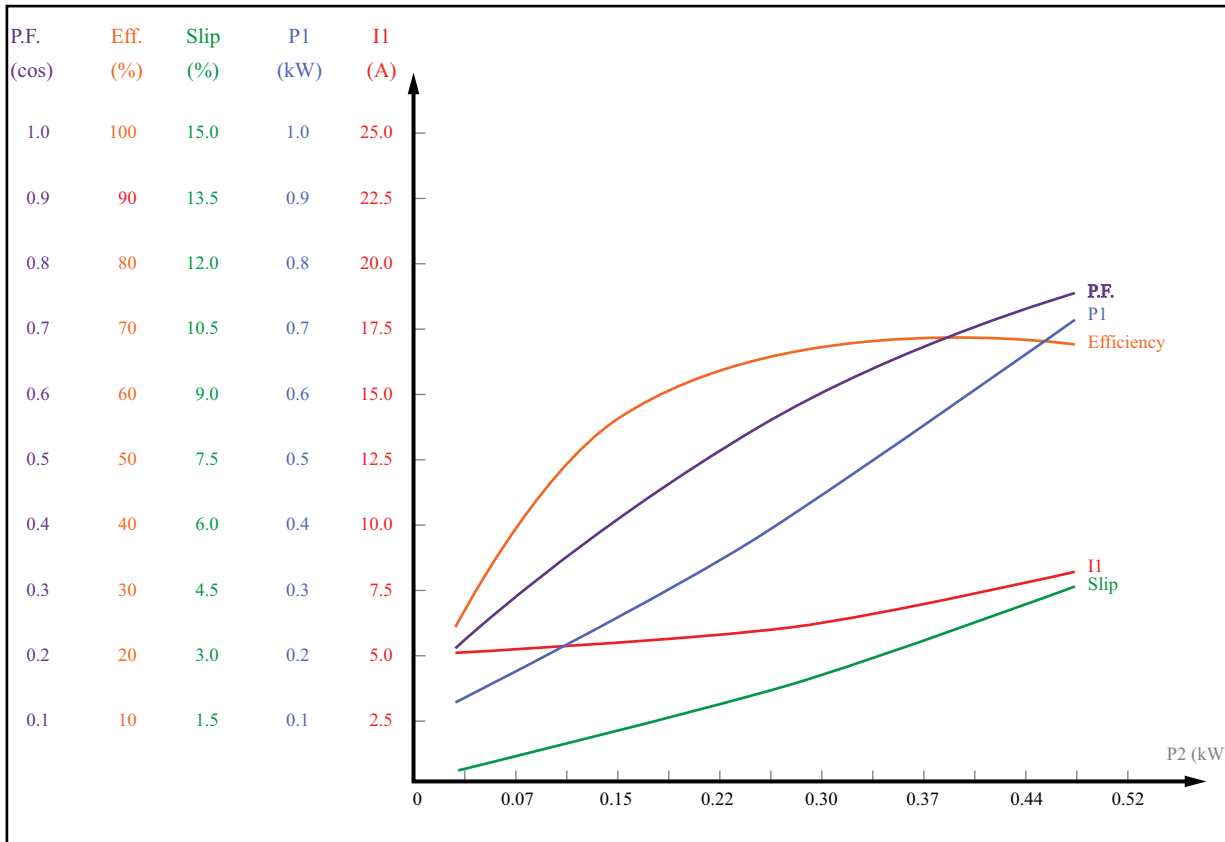

Performance Data - MTR2-P50-1AB18							
P2 (kW)	U (V)	I1 (A)	P1 (kW)	Torque (N·m)	Speed (RPM)	EFF (%)	P.F. (cos)
0.0916	115.9	5.39	0.2005	0.49	1784	45.66	0.32
0.1562	115.7	5.58	0.2725	0.84	1775	57.32	0.42
0.2037	115.6	5.79	0.3264	1.10	1768	62.41	0.49
0.2364	115.4	5.96	0.3644	1.28	1763	64.87	0.53
0.3100	115.2	6.47	0.4573	1.69	1751	67.78	0.61
0.3614	116.0	6.91	0.5252	1.98	1743	68.82	0.66
0.4258	115.6	7.53	0.6160	2.35	1730	69.13	0.71
0.4532	115.5	7.85	0.6589	2.51	1724	68.78	0.73

Load Performance Data - MTR2-P50-1AB18						
Load (%)	Current (A)	Input (kW)	Slip (%)	EFF (%)	P.F. (cos)	Output (kW)
25	5.39	0.2026	0.89	45.66	0.327	0.09
50	5.70	0.3038	1.58	60.89	0.464	0.19
75	6.23	0.4156	2.38	66.76	0.580	0.28
100	6.98	0.5381	3.28	68.76	0.670	0.37
125	7.95	0.6712	4.29	68.91	0.734	0.46

MTR2-P50-1AB36

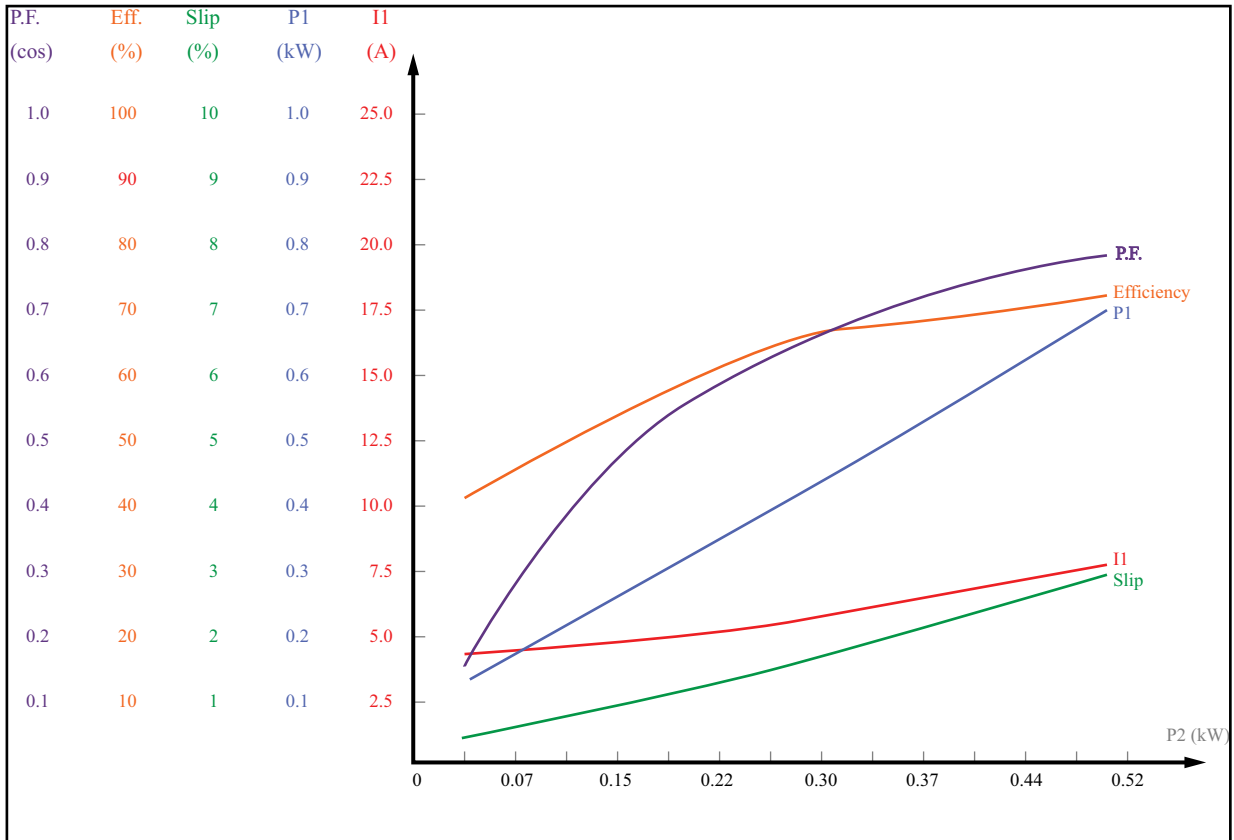

Performance Data - MTR2-P50-1AB36							
P2 (kW)	U (V)	I1 (A)	P1 (kW)	Torque (N·m)	Speed (RPM)	EFF (%)	P.F. (cos)
0.1420	115.2	4.72	0.2625	0.38	3567	54.09	0.48
0.1494	115.2	4.75	0.2695	0.40	3566	55.44	0.49
0.1974	115.1	5.04	0.3294	0.53	3557	59.94	0.57
0.2489	115.0	5.37	0.3873	0.67	3547	64.27	0.63
0.3148	115.8	5.86	0.4632	0.85	3536	67.97	0.68
0.3510	115.7	6.20	0.5131	0.95	3527	68.41	0.72
0.4266	115.5	6.91	0.6069	1.16	3511	70.30	0.76
0.4694	115.4	7.32	0.6587	1.28	3501	71.27	0.78

Load Performance Data - MTR2-P50-1AB36						
Load (%)	Current (A)	Input (kW)	Slip (%)	EFF (%)	P.F. (cos)	Output (kW)
25	4.46	0.2059	0.68	44.92	0.401	0.09
50	4.95	0.3122	1.10	59.27	0.548	0.19
75	5.58	0.4217	1.58	65.80	0.657	0.28
100	6.35	0.5346	2.10	69.21	0.732	0.37
125	7.26	0.6508	2.67	71.07	0.779	0.46

MTR2-P50-3BD18

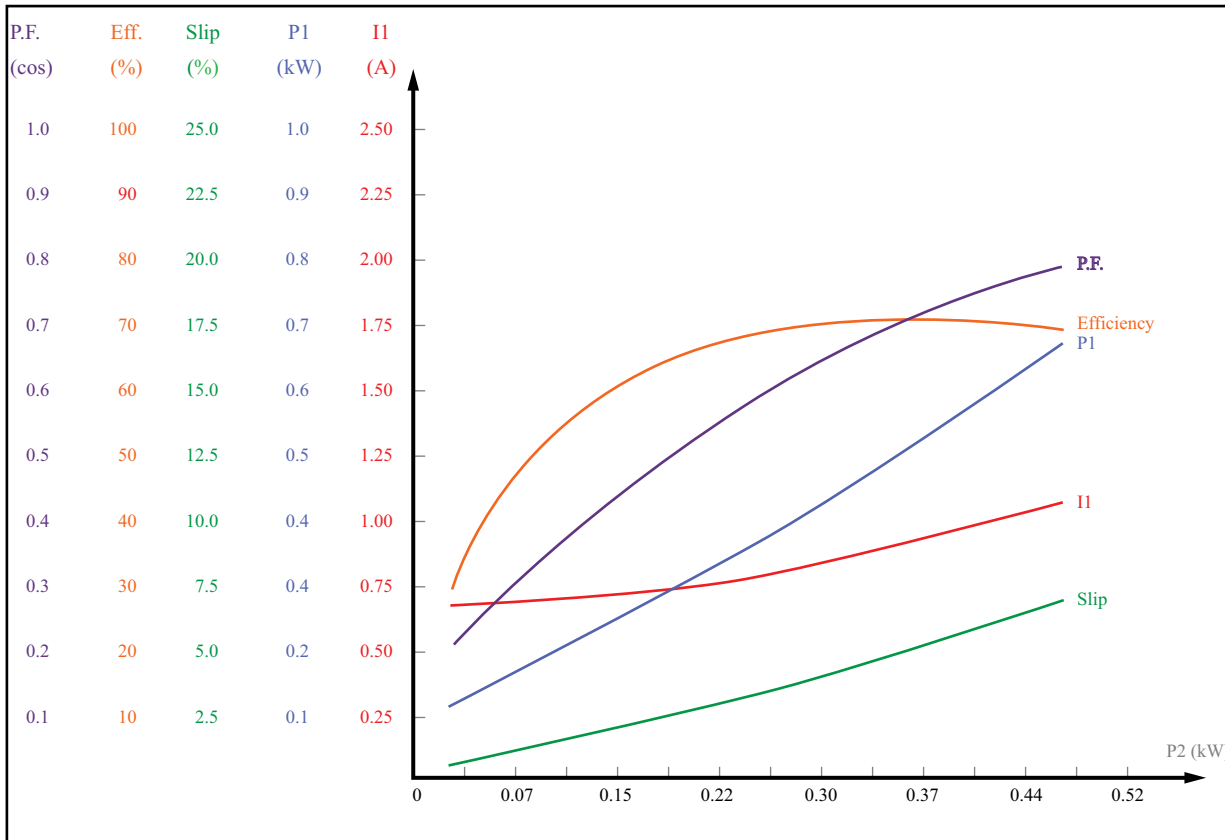

Performance Data - MTR2-P50-3BD18							
P2 (kW)	U (V)	I1 (A)	P1 (kW)	Torque (N·m)	Speed (RPM)	EFF (%)	P.F. (cos)
0.0784	460.5	0.68	0.1670	0.41	1780	46.97	0.31
0.1388	460.4	0.70	0.2340	0.76	1767	59.33	0.42
0.1898	460.2	0.74	0.2930	1.06	1755	64.78	0.50
0.2368	460.3	0.77	0.3490	1.32	1744	67.84	0.57
0.2947	460.2	0.82	0.4220	1.70	1728	60.84	0.64
0.3471	460.1	0.88	0.4910	2.01	1713	70.70	0.70
0.3957	460.1	0.95	0.5580	2.29	1698	70.91	0.74
0.4363	459.9	1.01	0.6180	2.55	1685	70.59	0.77

Load Performance Data - MTR2-P50-3BD18						
Load (%)	Current (A)	Input (kW)	Slip (%)	EFF (%)	P.F. (cos)	Output (kW)
25	0.69	0.1826	1.25	50.65	0.335	0.09
50	0.73	0.2866	2.37	64.56	0.492	0.19
75	0.81	0.4000	3.64	69.37	0.623	0.28
100	0.91	0.5230	5.07	70.74	0.719	0.37
125	1.05	0.6555	6.66	70.55	0.784	0.46

MTR2-P50-3BD36

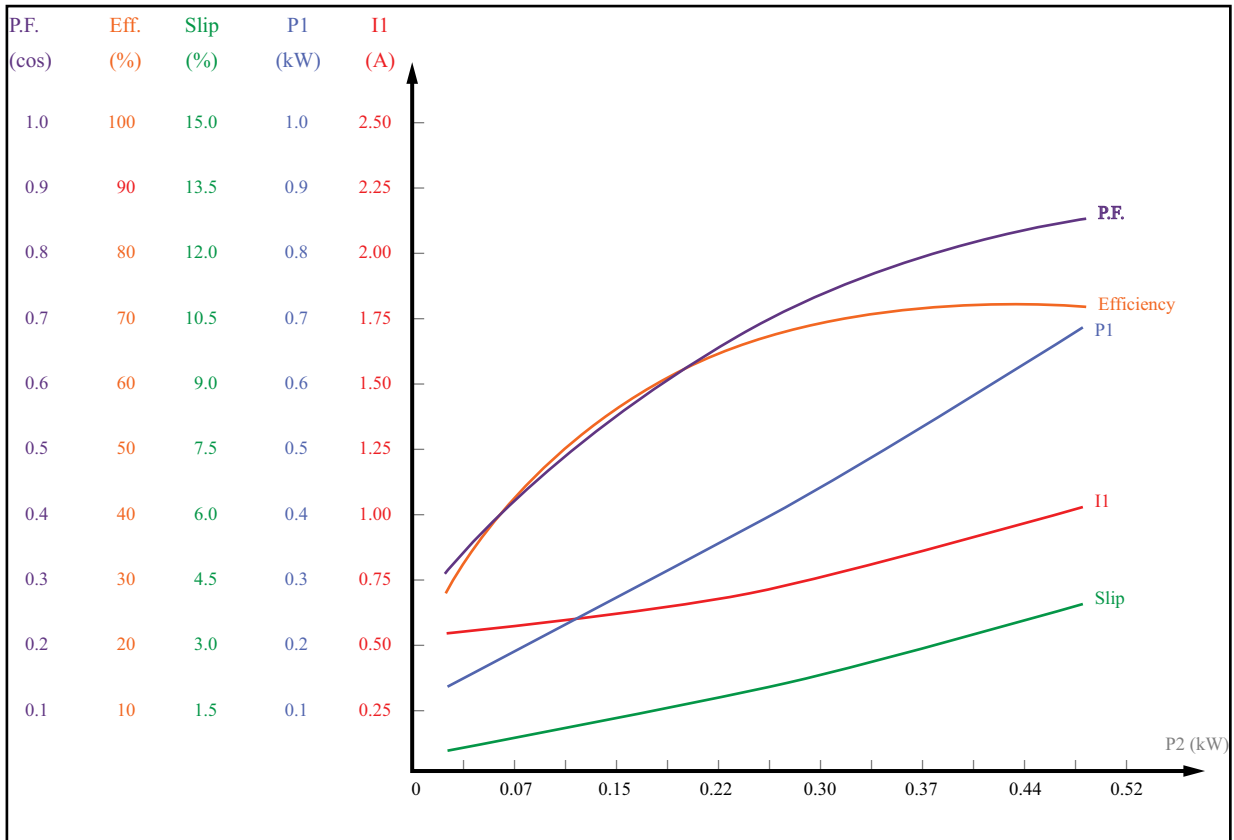

Performance Data - MTR2-P50-3BD36							
P2 (kW)	U (V)	I1 (A)	P1 (kW)	Torque (N·m)	Speed (RPM)	EFF (%)	P.F. (cos)
0.1263	460.2	0.58	0.2360	0.34	3560	53.50	0.51
0.1486	460.2	0.60	0.2610	0.41	3554	56.93	0.55
0.1752	460.1	0.62	0.2910	0.49	3548	60.21	0.59
0.2471	460.1	0.69	0.3740	0.69	3530	66.08	0.68
0.2957	460.0	0.74	0.4320	0.83	3517	68.45	0.73
0.3455	459.9	0.80	0.4930	0.96	3503	70.09	0.77
0.4075	459.9	0.89	0.5720	1.15	3484	71.24	0.81
0.4540	459.8	0.95	0.6330	1.28	3469	71.72	0.83

Load Performance Data - MTR2-P50-3BD36						
Load (%)	Current (A)	Input (kW)	Slip (%)	EFF (%)	P.F. (cos)	Output (kW)
25	0.56	0.1997	0.89	46.33	0.446	0.09
50	0.63	0.3019	1.45	61.29	0.601	0.19
75	0.72	0.4100	2.09	67.68	0.714	0.28
100	0.83	0.5241	2.80	70.60	0.790	0.37
125	0.97	0.6441	3.59	71.80	0.836	0.46

MTR2-P75-1AB18

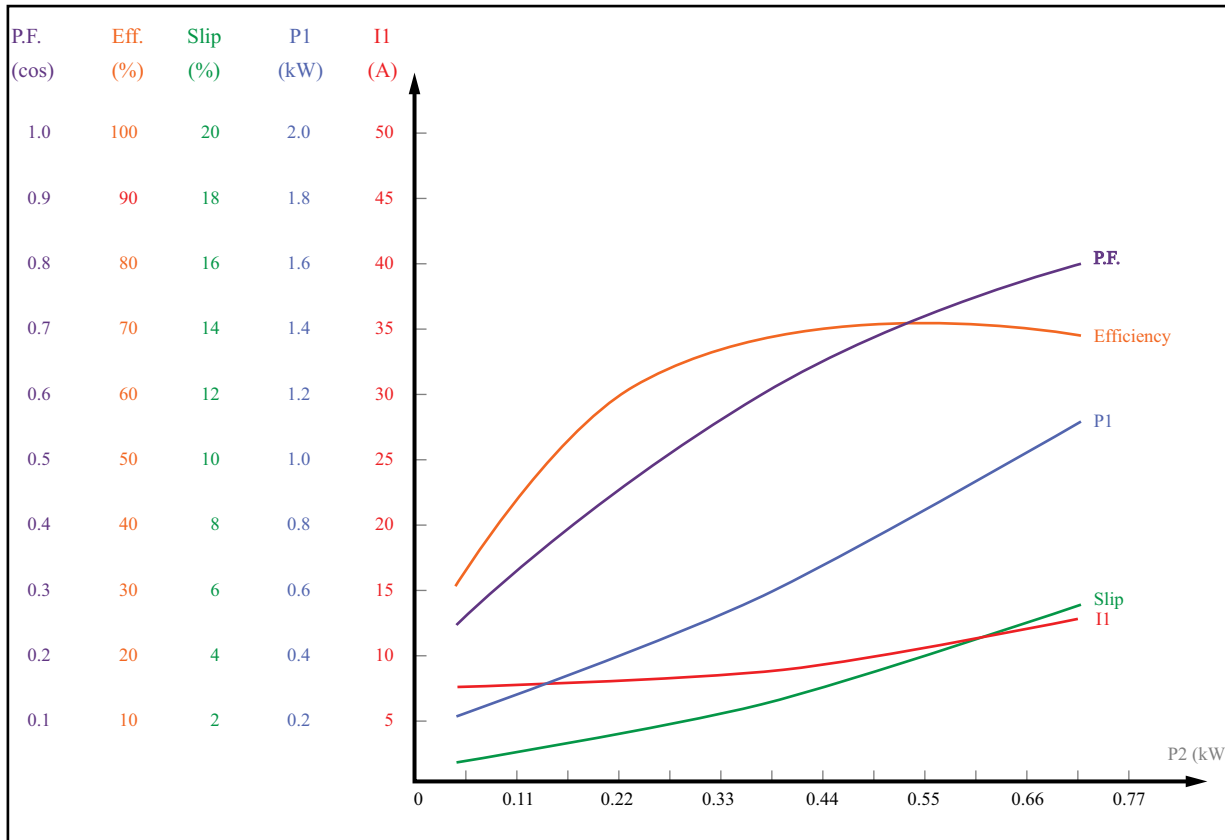

Performance Data - MTR2-P75-1AB18							
P2 (kW)	U (V)	I1 (A)	P1 (kW)	Torque (N·m)	Speed (RPM)	EFF (%)	P.F. (cos)
0.1456	115.2	7.15	0.2919	0.78	1782	49.87	0.35
0.2120	115.9	7.42	0.3668	1.14	1775	57.81	0.43
0.2943	115.6	7.79	0.4595	1.59	1766	64.04	0.51
0.3666	115.4	8.20	0.5433	1.99	1758	67.48	0.57
0.4576	115.0	8.89	0.6628	2.50	1746	69.04	0.65
0.5352	115.7	9.60	0.7693	2.94	1737	69.57	0.70
0.6332	115.3	10.69	0.9174	3.51	1720	69.02	0.74
0.6855	115.0	11.37	1.0017	3.82	1711	68.43	0.77

Load Performance Data - MTR2-P75-1AB18						
Load (%)	Current (A)	Input (kW)	Slip (%)	EFF (%)	P.F. (cos)	Output (kW)
25	7.16	0.2866	0.96	47.97	0.348	0.14
50	7.66	0.4344	1.68	63.30	0.493	0.28
75	8.52	0.6032	2.56	68.39	0.615	0.41
100	9.77	0.7928	3.60	69.37	0.706	0.55
125	11.37	1.0035	4.80	68.51	0.767	0.69

MTR2-P75-1AB36

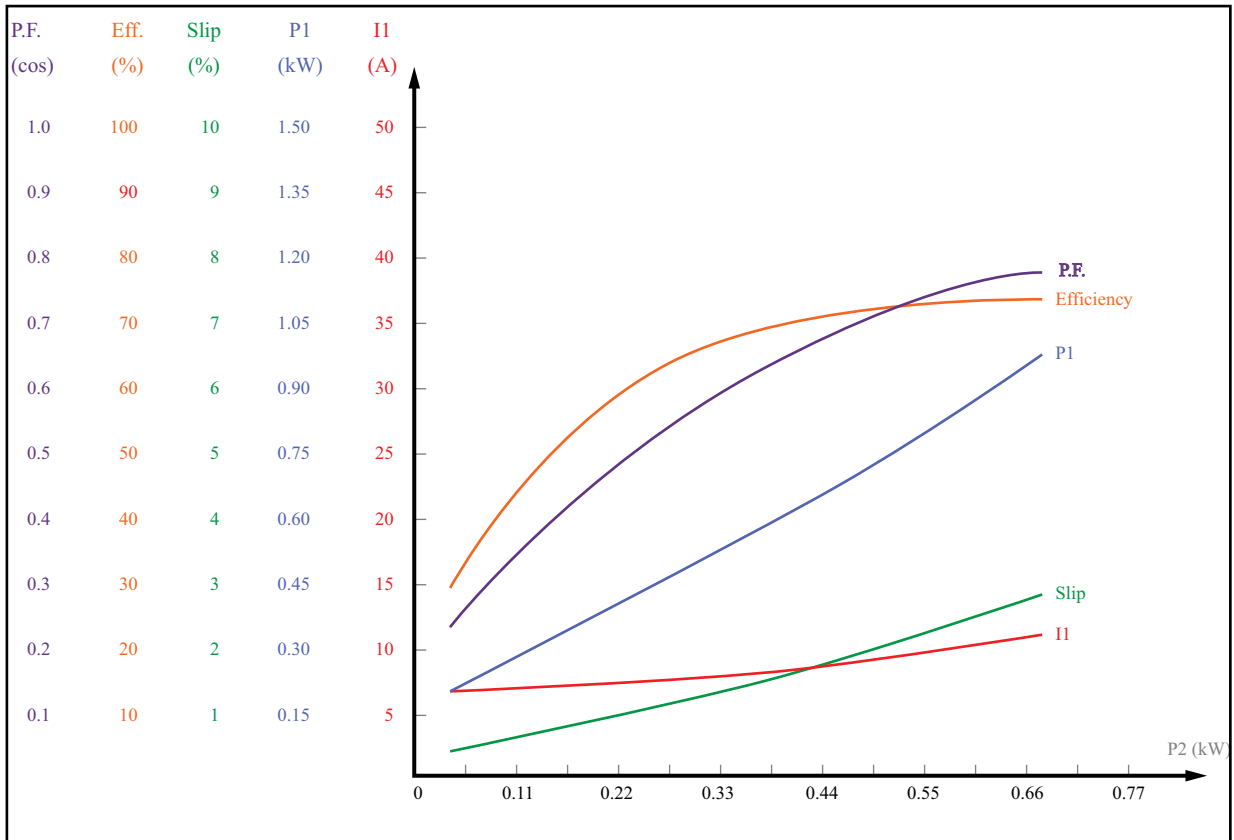

Performance Data - MTR2-P75-1AB36							
P2 (kW)	U (V)	I1 (A)	P1 (kW)	Torque (N·m)	Speed (RPM)	EFF (%)	P.F. (cos)
0.1386	115.9	6.65	0.2901	0.37	3578	47.79	0.38
0.1945	115.8	6.85	0.3550	0.52	3571	54.79	0.45
0.2650	115.7	7.14	0.4249	0.71	3563	62.35	0.52
0.3608	115.6	7.69	0.5328	0.97	3551	67.72	0.60
0.4485	115.4	8.31	0.6375	1.21	3539	70.35	0.66
0.5320	115.2	9.00	0.7403	1.44	3527	71.87	0.71
0.6326	115.0	9.97	0.8719	1.72	3511	72.55	0.76
0.6541	115.0	10.19	0.8988	1.78	3507	72.77	0.77

Load Performance Data - MTR2-P75-1AB36						
Load (%)	Current (A)	Input (kW)	Slip (%)	EFF (%)	P.F. (cos)	Output (kW)
25	6.64	0.2916	0.61	47.15	0.382	0.14
50	7.20	0.4370	1.04	62.93	0.528	0.28
75	8.04	0.5943	1.53	69.41	0.643	0.41
100	9.16	0.7635	2.08	72.04	0.725	0.55
125	10.56	0.9446	2.68	72.78	0.778	0.69

MTR2-P75-3BD18

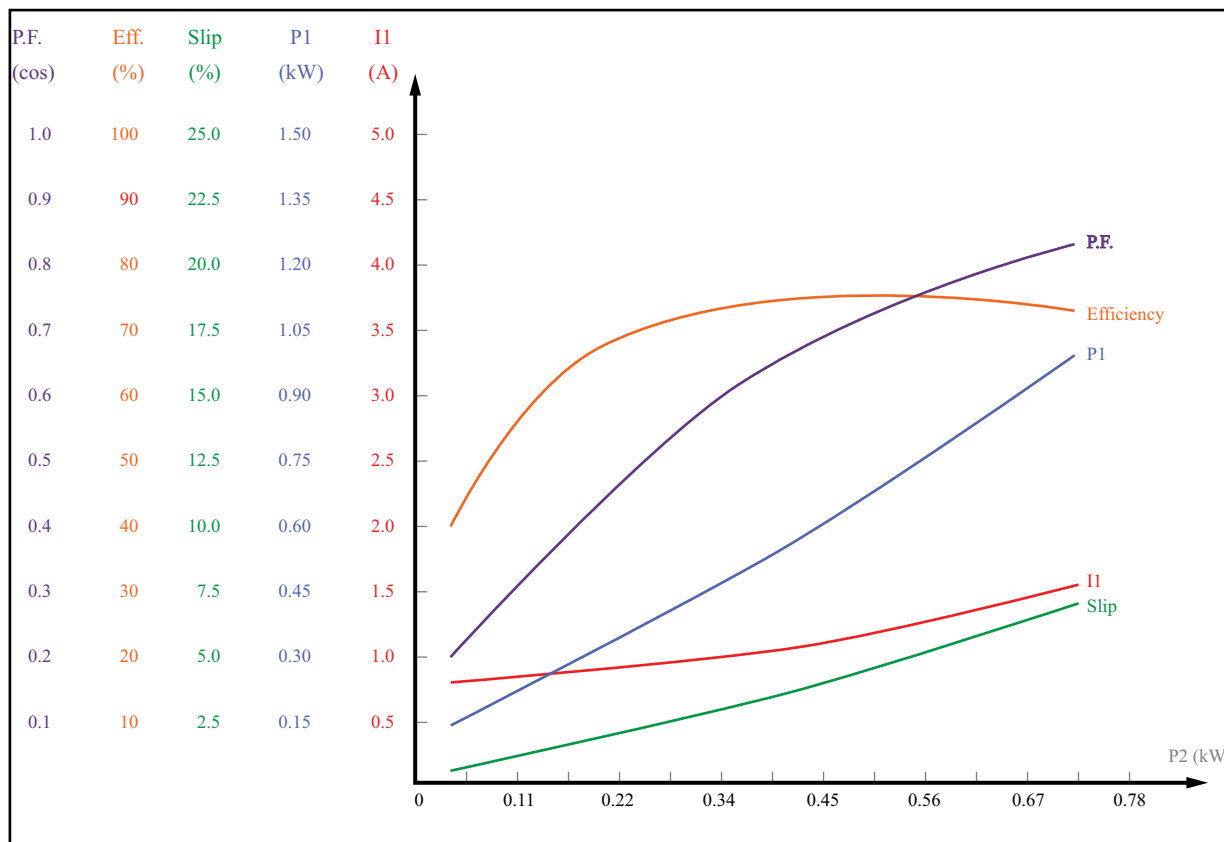

Performance Data - MTR2-P75-3BD18							
P2 (kW)	U (V)	I1 (A)	P1 (kW)	Torque (N·m)	Speed (RPM)	EFF (%)	P.F. (cos)
0.1144	460.9	0.83	0.2060	0.62	1782	55.56	0.31
0.2075	460.8	0.87	0.3090	1.16	1769	67.15	0.45
0.2857	460.7	0.92	0.3990	1.60	1757	71.61	0.54
0.3585	460.6	0.99	0.4860	2.02	1745	73.77	0.62
0.4412	460.6	1.08	0.5890	2.49	1731	74.91	0.69
0.5204	460.4	1.18	0.6930	2.98	1716	75.10	0.74
0.5971	460.3	1.29	0.7990	3.45	1701	74.74	0.78
0.6675	460.2	1.40	0.9020	3.90	1686	74.00	0.81

Load Performance Data - MTR2-P75-3BD18						
Load (%)	Current (A)	Input (kW)	Slip (%)	EFF (%)	P.F. (cos)	Output (kW)
25	0.84	0.2342	1.28	59.77	0.352	0.14
50	0.92	0.3911	2.31	71.58	0.534	0.28
75	1.05	0.5625	3.55	74.67	0.671	0.42
100	1.23	0.7482	4.99	74.84	0.762	0.56
125	1.46	0.9484	6.63	73.81	0.815	0.70

MTR2-P75-3BD36

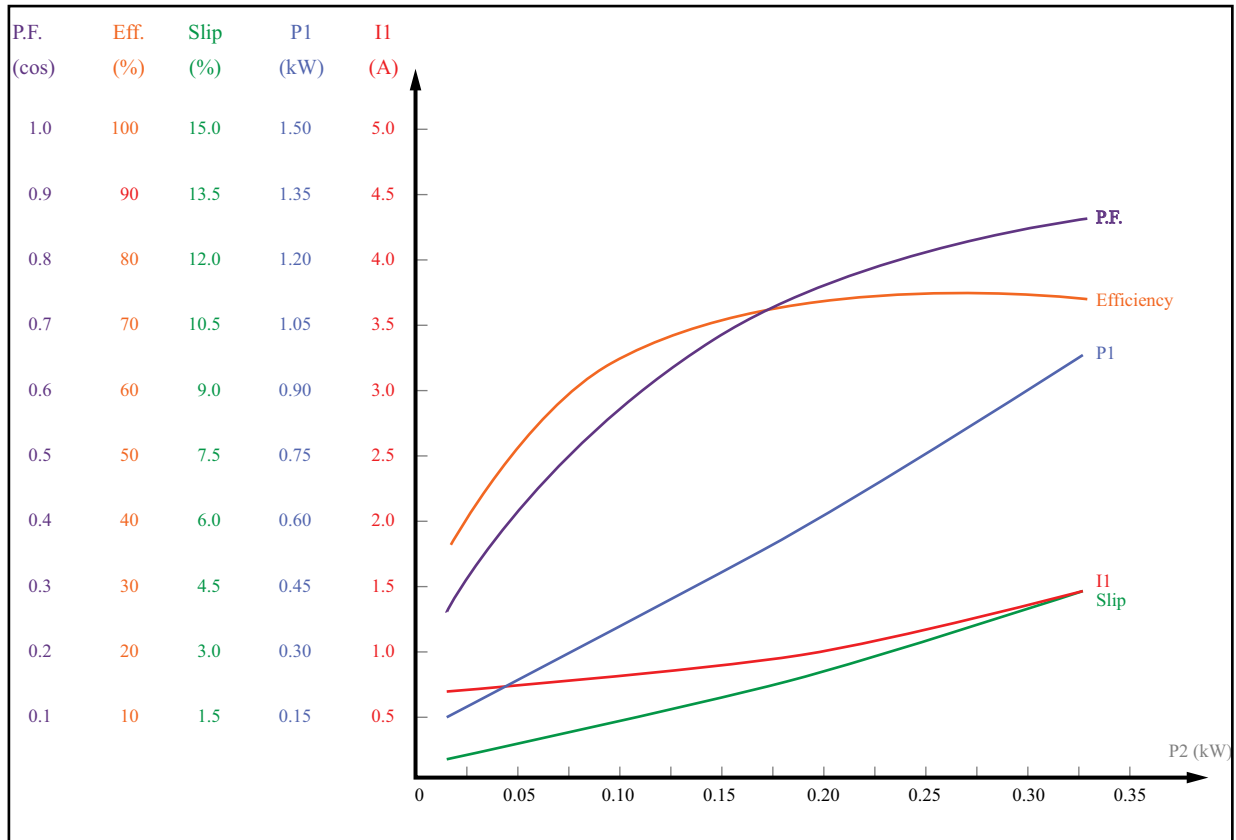

Performance Data - MTR2-P75-3BD36							
P2 (kW)	U (V)	I1 (A)	P1 (kW)	Torque (N·m)	Speed (RPM)	EFF (%)	P.F. (cos)
0.1569	460.4	0.73	0.2730	0.41	3564	57.46	0.47
0.2434	460.3	0.79	0.3690	0.65	3549	65.98	0.59
0.2986	460.2	0.84	0.4320	0.81	3538	69.12	0.64
0.3545	460.1	0.90	0.4970	0.97	3527	71.33	0.70
0.4555	460.0	1.01	0.6180	1.25	3506	73.71	0.77
0.5293	460.9	1.11	0.7100	1.46	3489	74.55	0.80
0.6055	460.8	1.22	0.8080	1.68	3471	74.94	0.83
0.6800	459.7	1.34	0.9080	1.89	3453	74.89	0.85

Load Performance Data - MTR2-P75-3BD36						
Load (%)	Current (A)	Input (kW)	Slip (%)	EFF (%)	P.F. (cos)	Output (kW)
25	0.72	0.2554	0.92	54.82	0.446	0.14
50	0.83	0.4102	1.58	68.27	0.624	0.28
75	0.70	0.5749	2.33	73.06	0.744	0.42
100	1.15	0.7496	3.17	74.70	0.818	0.56
125	1.37	0.9344	4.10	74.92	0.856	0.70

MTR2-001-1AB18

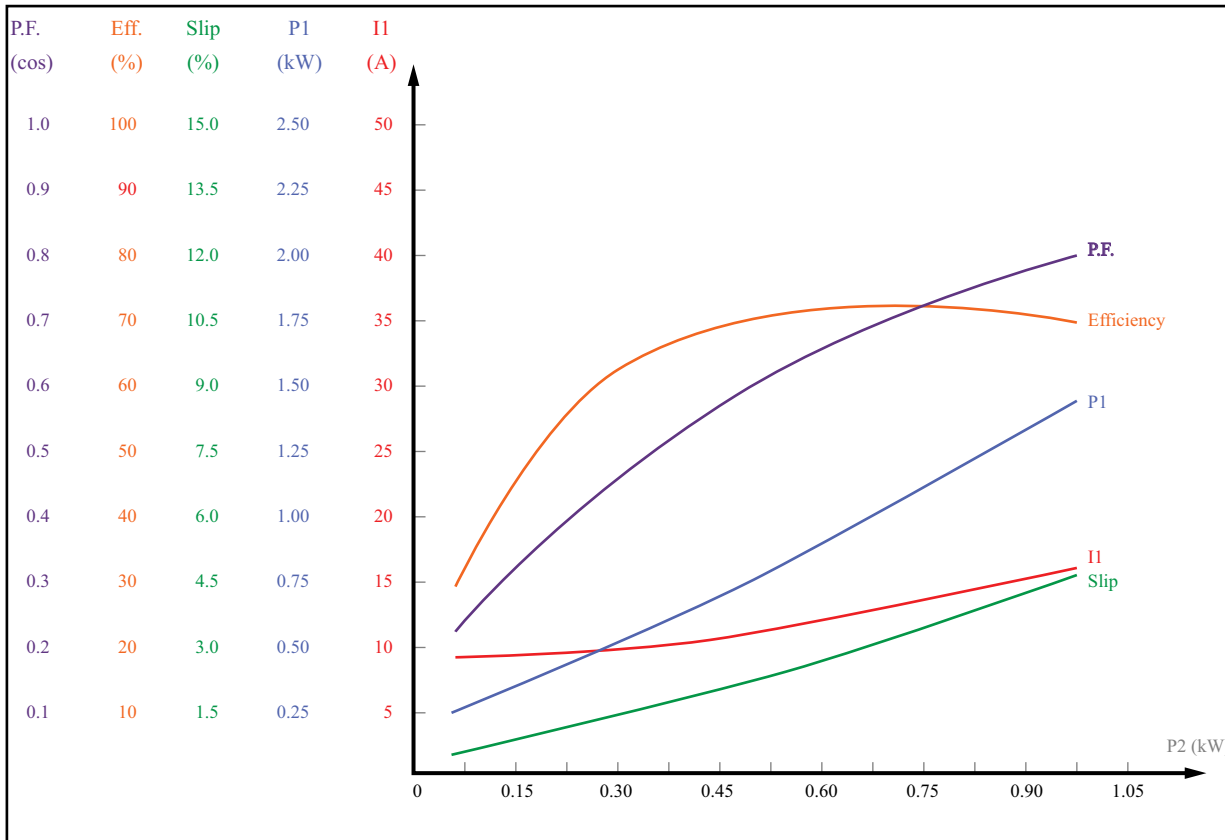

Performance Data - MTR2-001-1AB18							
P2 (kW)	U (V)	I1 (A)	P1 (kW)	Torque (N·m)	Speed (RPM)	EFF (%)	P.F. (cos)
0.2110	115.6	9.16	0.3910	1.13	1784	53.97	0.37
0.2960	115.5	9.47	0.4820	1.59	1778	61.42	0.44
0.4042	115.3	9.99	0.6040	2.18	1771	66.91	0.53
0.5023	115.1	10.62	0.7220	2.72	1763	69.56	0.59
0.6193	115.8	11.57	0.8720	3.37	1755	71.02	0.65
0.7223	115.7	12.47	1.0060	3.95	1746	71.79	0.70
0.8290	115.5	13.56	1.1540	4.56	1736	71.84	0.74
0.9342	115.2	14.85	1.3171	5.18	1726	70.93	0.77

Load Performance Data - MTR2-001-1AB18						
Load (%)	Current (A)	Input (kW)	Slip (%)	EFF (%)	P.F. (cos)	Output (kW)
25	9.08	0.3675	0.86	51.02	0.352	0.19
50	9.85	0.5702	1.51	65.76	0.504	0.38
75	11.07	0.7964	2.27	70.63	0.626	0.56
100	12.75	1.0460	3.15	71.70	0.714	0.75
125	14.88	1.3191	4.14	71.07	0.771	0.94

MTR2-001-1AB36

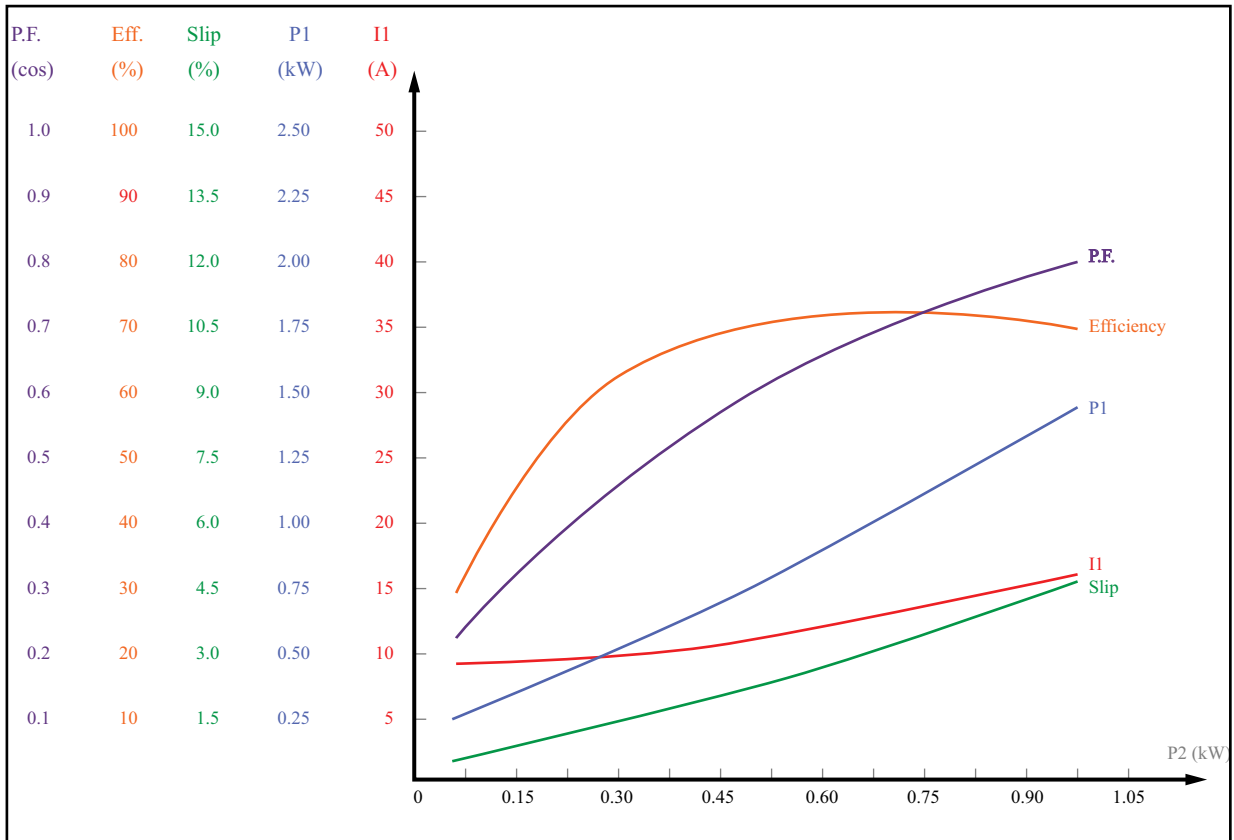

Performance Data - MTR2-001-1AB36							
P2 (kW)	U (V)	I1 (A)	P1 (kW)	Torque (N·m)	Speed (RPM)	EFF (%)	P.F. (cos)
0.1760	114.9	6.28	0.3174	0.47	3577	0.1760	0.44
0.2727	115.8	6.79	0.4202	0.73	3567	0.2727	0.53
0.4093	115.5	7.64	0.5720	1.10	3552	0.4093	0.65
0.5080	115.3	8.43	0.6908	1.37	3540	0.5080	0.71
0.6280	116.1	9.50	0.8375	1.70	3527	0.6280	0.76
0.7250	115.9	10.51	0.9692	1.97	3513	0.7250	0.80
0.8635	115.6	12.13	1.1626	2.36	3492	0.8635	0.83
0.9335	115.4	13.03	1.2652	2.56	3480	0.9335	0.84

Load Performance Data - MTR2-001-1AB36						
Load (%)	Current (A)	Input (kW)	Slip (%)	EFF (%)	P.F. (cos)	Output (kW)
25	6.34	0.3300	0.68	56.82	0.452	0.19
50	7.41	0.5324	1.19	70.44	0.624	0.38
75	8.89	0.7567	1.79	74.34	0.740	0.56
100	10.78	1.0028	2.49	74.79	0.809	0.75
125	13.08	1.2708	3.27	73.77	0.845	0.94

MTR2-002-1AB18

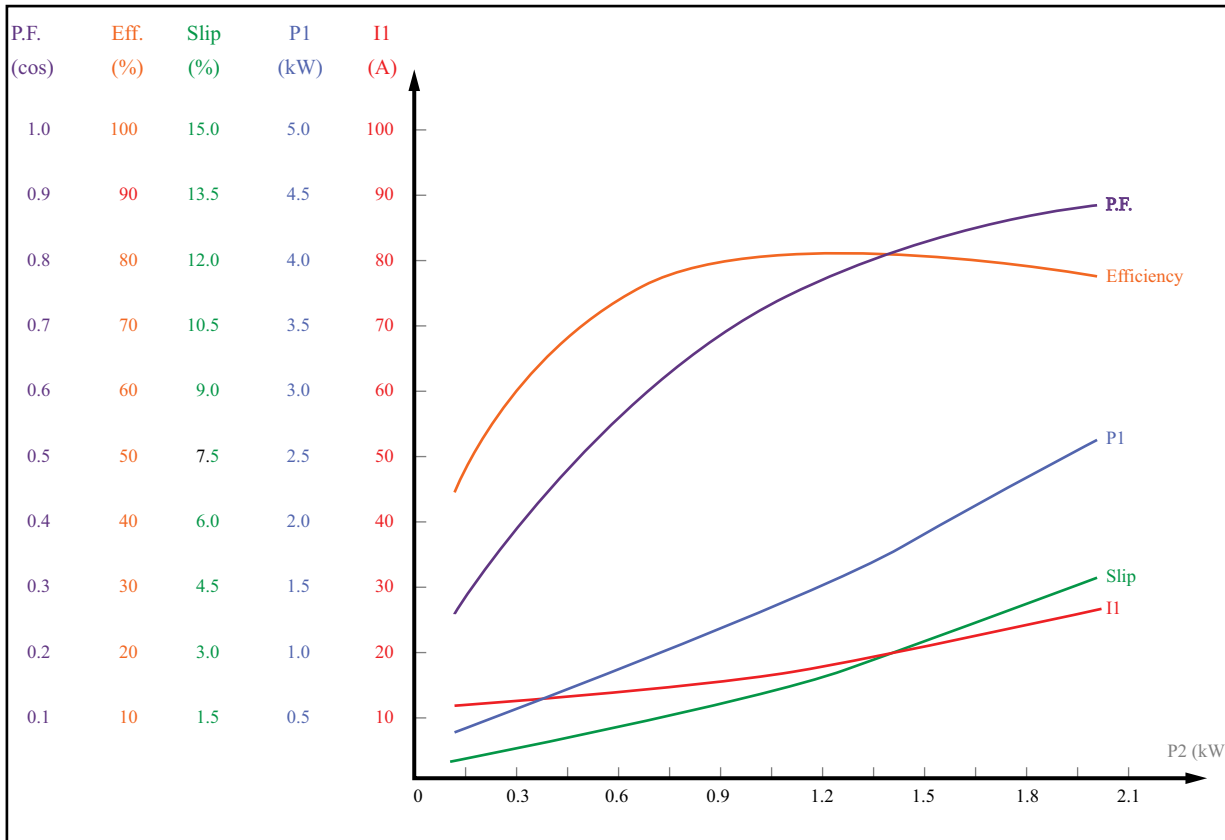

Performance Data - MTR2-002-1AB18							
P2 (kW)	U (V)	I1 (A)	P1 (kW)	Torque (N·m)	Speed (RPM)	EFF (%)	P.F. (cos)
0.3760	115.1	11.68	0.5858	2.01	1786	64.19	0.44
0.5816	115.7	12.63	0.7988	3.12	1780	72.81	0.55
0.8182	115.4	13.85	1.0457	4.41	1771	78.25	0.65
1.0346	116.1	15.45	1.2924	5.60	1764	80.05	0.72
1.2680	115.7	17.38	1.5732	6.90	1754	80.60	0.78
1.4453	115.4	19.07	1.7969	7.90	1746	80.43	0.82
1.7366	114.9	22.23	2.1852	9.57	1732	79.47	0.86
1.8752	114.7	23.98	2.3878	10.38	1724	78.53	0.87

Load Performance Data - MTR2-002-1AB18						
Load (%)	Current (A)	Input (kW)	Slip (%)	EFF (%)	P.F. (cos)	Output (kW)
25	11.69	0.5882	0.77	63.76	0.438	0.38
50	13.49	0.9717	1.41	77.19	0.626	0.75
75	16.14	1.3988	2.18	80.43	0.754	1.13
100	19.63	1.8695	3.10	80.23	0.828	1.50
125	23.96	2.3839	4.14	78.65	0.865	1.88

MTR2-002-1AB36

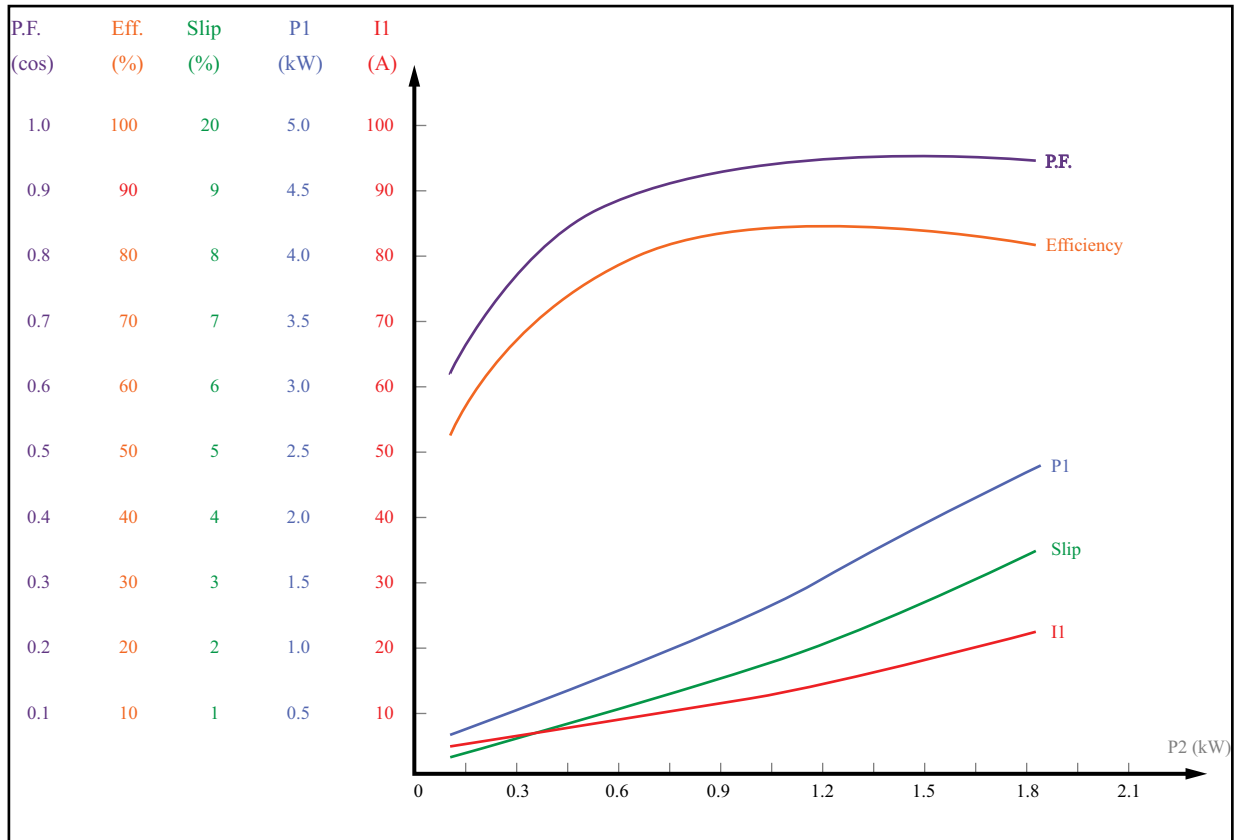

Performance Data - MTR2-002-1AB36							
P2 (kW)	U (V)	I1 (A)	P1 (kW)	Torque (N·m)	Speed (RPM)	EFF (%)	P.F. (cos)
0.3748	116.0	5.86	0.5413	1.00	3578	69.23	0.80
0.6236	115.6	7.80	0.7952	1.67	3565	78.42	0.88
0.8115	115.3	9.45	0.9960	2.18	3554	81.47	0.91
1.0057	116.0	11.24	1.2086	2.71	3543	83.20	0.93
1.2451	115.6	13.69	1.4854	3.37	3527	83.82	0.94
1.4601	115.2	16.18	1.7620	3.97	3510	82.87	0.95
1.7225	115.7	19.22	2.1052	4.71	3490	81.82	0.95
1.7682	115.6	19.79	2.1650	4.84	3487	81.67	0.95

Load Performance Data - MTR2-002-1AB36						
Load (%)	Current (A)	Input (kW)	Slip (%)	EFF (%)	P.F. (cos)	Output (kW)
25	5.85	0.5440	0.60	68.94	0.809	0.38
50	8.89	0.9259	1.14	81.00	0.905	0.75
75	12.46	1.3481	1.78	83.45	0.941	1.13
100	16.56	1.8105	2.51	82.85	0.951	1.50
125	21.17	2.3130	3.34	81.06	0.950	1.88

MTR2-1P5-1AB18

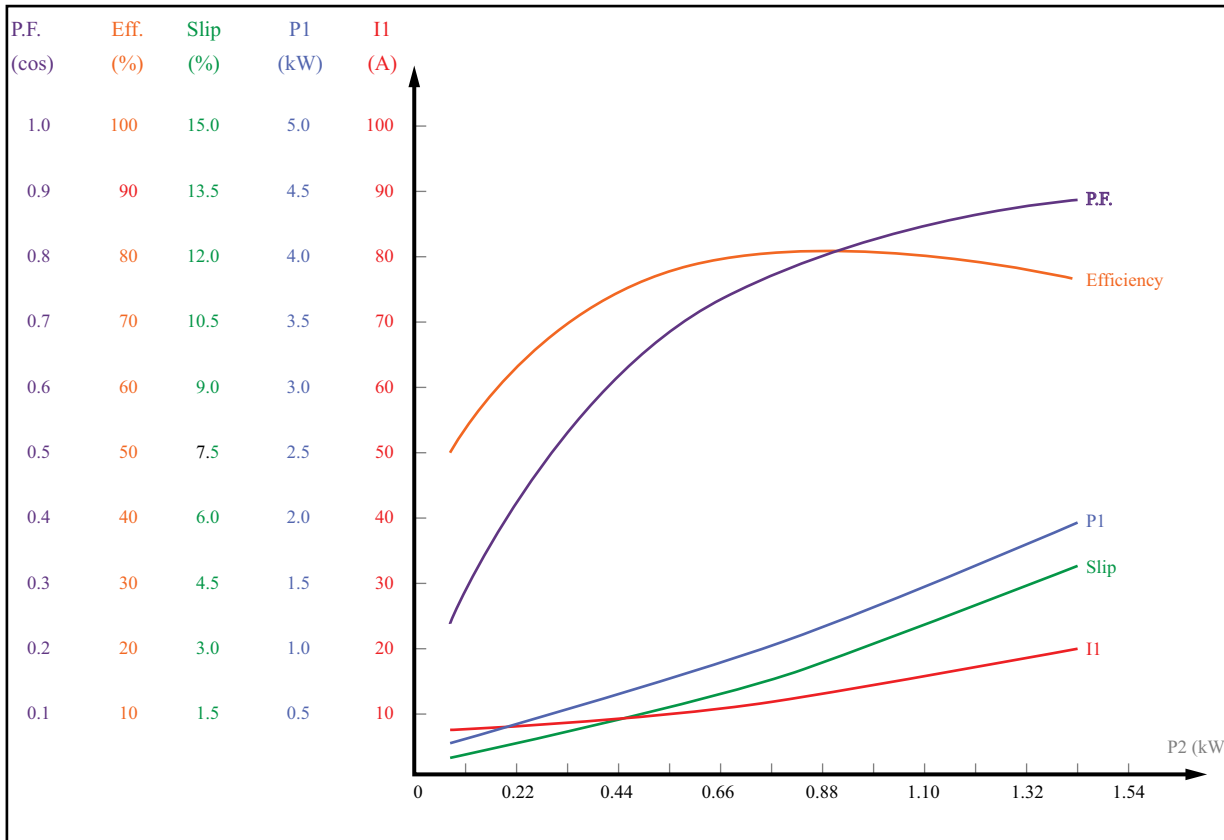

Performance Data - MTR2-1P5-1AB18							
P2 (kW)	U (V)	I1 (A)	P1 (kW)	Torque (N·m)	Speed (RPM)	EFF (%)	P.F. (cos)
0.2750	115.7	7.75	0.4180	1.47	1786	65.78	0.47
0.3982	115.5	8.33	0.5490	2.13	1780	72.35	0.57
0.5880	115.2	9.57	0.7568	3.17	1771	77.69	0.69
0.7278	115.0	10.64	0.9147	3.94	1763	79.56	0.75
0.9236	115.7	12.43	1.1484	5.03	1753	80.43	0.80
1.0843	115.4	14.09	1.3550	5.94	1742	80.02	0.83
1.2648	115.1	16.22	1.6034	6.98	1729	78.88	0.86
1.3773	114.8	17.70	1.7690	7.64	1720	77.86	0.87

Load Performance Data - MTR2-1P5-1AB18						
Load (%)	Current (A)	Input (kW)	Slip (%)	EFF (%)	P.F. (cos)	Output (kW)
25	7.74	0.4223	0.78	65.11	0.475	0.28
50	9.30	0.7101	1.47	77.46	0.664	0.55
75	11.48	1.0282	2.29	80.16	0.780	0.83
100	14.27	1.3799	3.24	79.72	0.841	1.10
125	17.67	1.7619	4.33	78.04	0.867	1.38

MTR2-1P5-1AB36

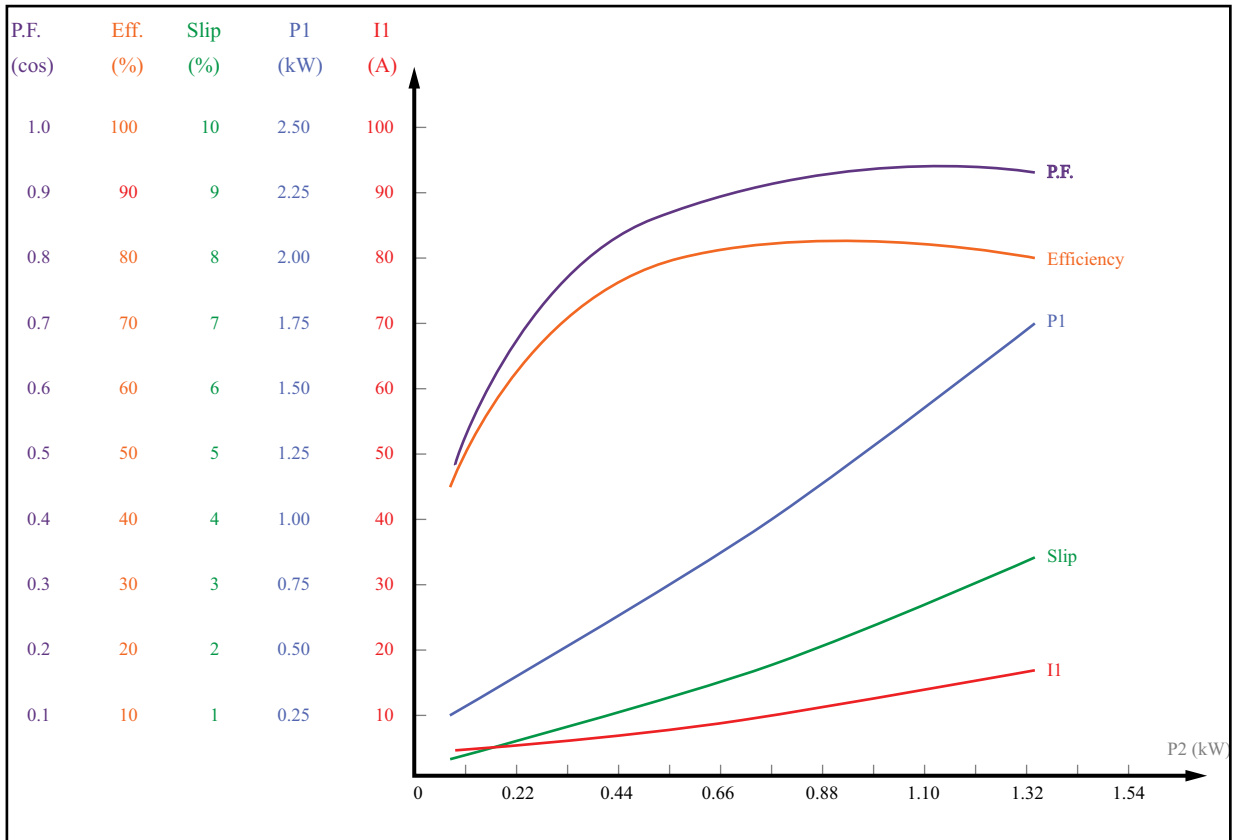

Performance Data - MTR2-1P5-1AB36							
P2 (kW)	U (V)	I1 (A)	P1 (kW)	Torque (N·m)	Speed (RPM)	EFF (%)	P.F. (cos)
0.2996	116.3	5.23	0.4448	0.80	3577	67.37	0.73
0.4407	116.1	6.22	0.5908	1.18	3566	74.60	0.82
0.6177	115.8	7.65	0.7767	1.66	3553	79.52	0.88
0.7238	115.6	8.61	0.8937	1.95	3544	80.99	0.90
0.9196	115.3	10.66	1.1335	2.49	3526	81.13	0.92
1.0630	115.0	12.18	1.3044	2.89	3512	81.49	0.93
1.2126	115.8	13.85	1.5002	3.31	3498	80.83	0.94
1.2830	115.6	14.74	1.5962	3.51	3490	80.38	0.94

Load Performance Data - MTR2-1P5-1AB36						
Load (%)	Current (A)	Input (kW)	Slip (%)	EFF (%)	P.F. (cos)	Output (kW)
25	5.03	0.4214	0.60	65.25	0.729	0.28
50	7.11	0.7039	1.16	78.13	0.861	0.55
75	9.62	1.0148	1.79	81.30	0.917	0.83
100	12.56	1.3540	2.51	81.24	0.937	1.10
125	15.92	1.7215	3.32	79.87	0.940	1.38

PERFORMANCE CURVES FOR MTDP MOTORS

MTDP-001-3BD18

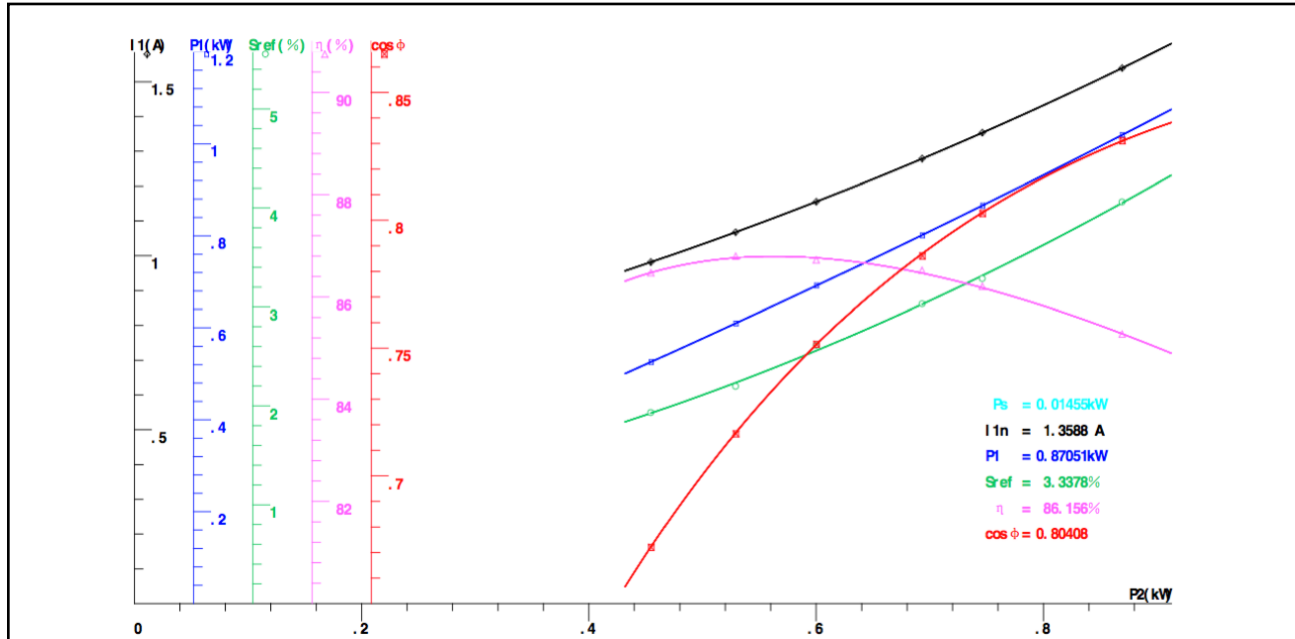

I 1j (A)	Pcu1s(kW)	Pcu2s(kW)	Sref (%)	Srefj (%)	Ps (kW)	P2 (kW)	nref(r/min)	Tref(N.m.)	η (%)	η j (%)	cos Φ	cosj Φ
1.539	0.0624	0.0379	4.060	4.050	0.0195	0.8691	1726.8	4.768	85.27	85.28	0.8311	0.8310
1.353	0.0482	0.0261	3.286	3.316	0.0144	0.7462	1740.8	4.102	86.21	86.18	0.8027	0.8030
1.279	0.0431	0.0223	3.030	3.027	0.0118	0.6932	1745.4	3.717	86.52	86.47	0.7860	0.7869
1.155	0.0352	0.0165	2.610	2.558	0.0091	0.6001	1753.0	3.260	86.72	86.76	0.7515	0.7514
1.068	0.0300	0.0122	2.197	2.234	0.0070	0.5291	1760.4	2.854	86.80	86.77	0.7164	0.7168
0.9818	0.0254	0.0092	1.931	1.926	0.0050	0.4547	1765.2	2.428	86.47	86.47	0.6720	0.6722

Rated Power	P1 (kW)	I 1 (A)	Sref (%)	n (speed)	Pcu1(kW)	Pcu2(kW)	Ps(kW)	P2 (kW)	T (N.m.)	η (%)	cos Φ
150%	1.107	1.651	4.496	1719.1	0.0718	0.0455	0.0224	0.9375	5.110	84.67	0.8419
125%	1.011	1.529	4.008	1727.9	0.0615	0.0371	0.0192	0.8625	4.734	85.34	0.8297
100%	0.8705	1.359	3.338	1739.9	0.0486	0.0267	0.0146	0.7500	4.123	86.16	0.8041
75%	0.6481	1.108	2.383	1757.1	0.0323	0.0141	0.0079	0.5625	3.044	86.79	0.7339
50%	0.4377	0.8961	1.631	1770.6	0.0211	0.0064	0.0034	0.3750	1.995	85.68	0.6131
25%	0.2365	0.7191	1.082	1780.5	0.0136	0.0021	0.0010	0.1875	1.100	79.27	0.4128

MTDP-1P5-3BD18

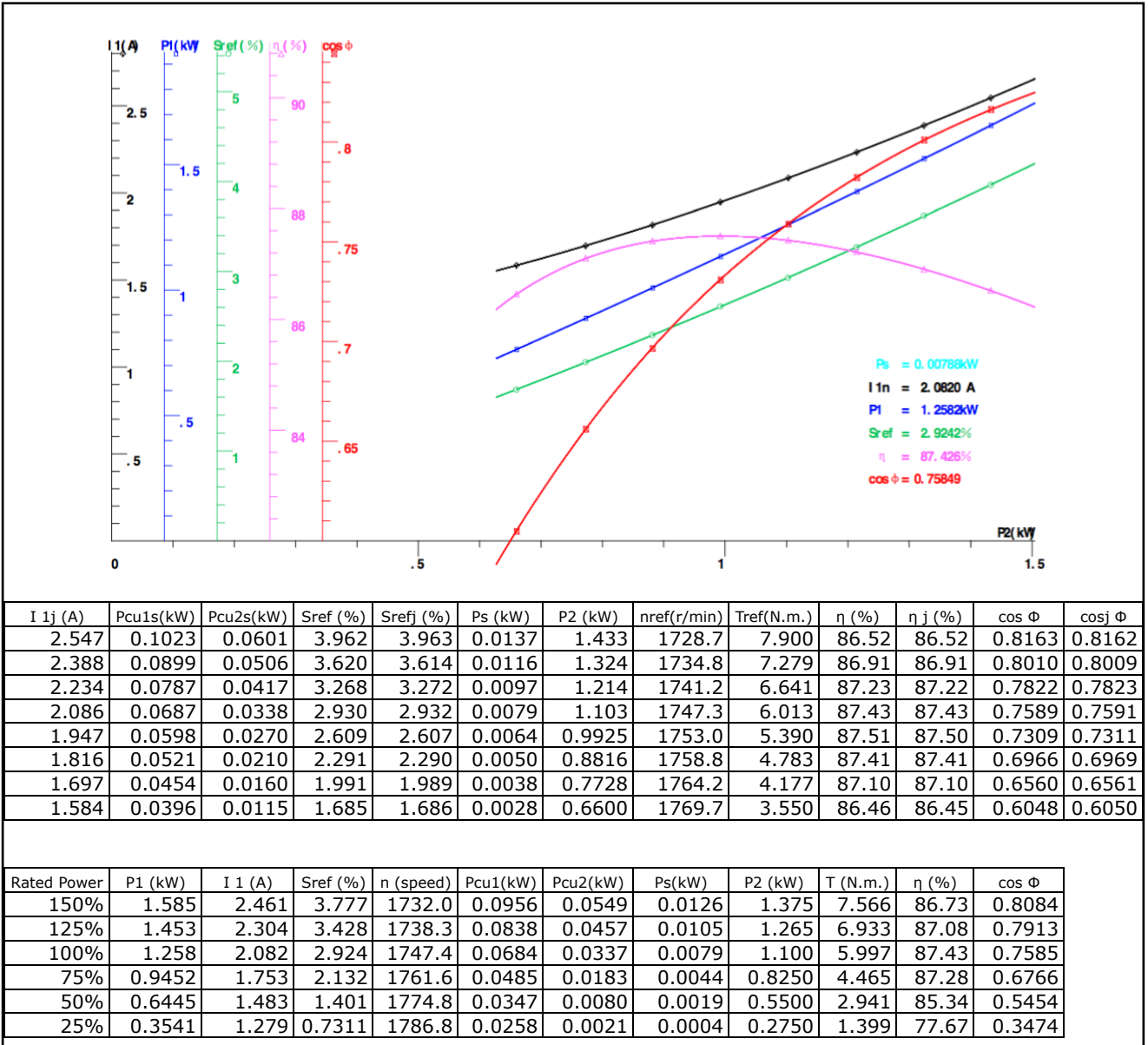

MTDP-002-3BD18

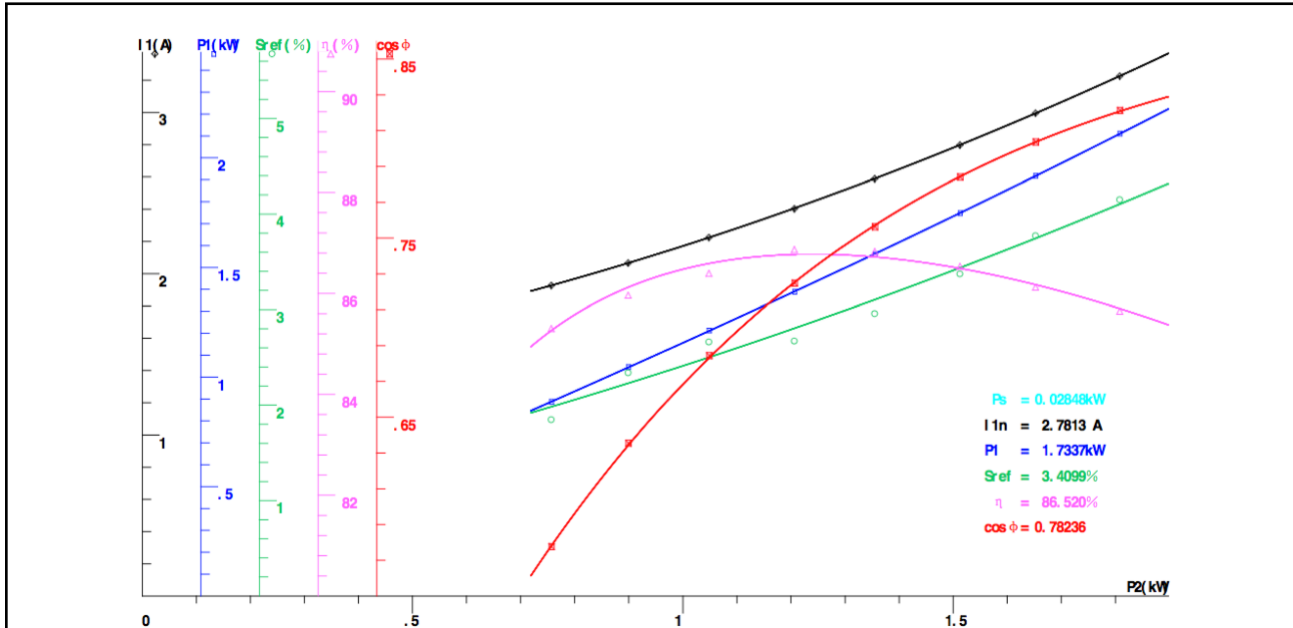

I 1j (A)	Pcu1s(kW)	Pcu2s(kW)	Sref (%)	Srefj (%)	Ps (kW)	P2 (kW)	nref(r/min)	Tref(N.m.)	η (%)	η j (%)	cos Φ	cosj Φ
3.226	0.1186	0.0805	4.150	4.104	0.0420	1.808	1725.2	9.946	85.65	85.70	0.8212	0.8207
2.994	0.1023	0.0665	3.772	3.745	0.0349	1.652	1732.0	9.070	86.12	86.17	0.8036	0.8036
2.798	0.0892	0.0541	3.372	3.437	0.0289	1.513	1739.2	8.260	86.53	86.50	0.7840	0.7843
2.589	0.0764	0.0422	2.958	3.103	0.0231	1.355	1746.7	7.380	86.83	86.72	0.7563	0.7571
2.406	0.0659	0.0338	2.671	2.804	0.0183	1.206	1751.8	6.569	86.87	86.77	0.7248	0.7252
2.224	0.0564	0.0293	2.662	2.500	0.0137	1.048	1752.0	5.692	86.40	86.59	0.6844	0.6830
2.066	0.0486	0.0220	2.339	2.229	0.0101	0.8992	1757.8	4.875	85.96	86.12	0.6354	0.6343
1.927	0.0423	0.0145	1.848	1.983	0.0069	0.7567	1766.7	4.036	85.31	85.26	0.5776	0.5780

Rated Power	P1 (kW)	I 1 (A)	Sref (%)	n (speed)	Pcu1(kW)	Pcu2(kW)	Ps(kW)	P2 (kW)	T (N.m.)	η (%)	cos Φ
150%	2.194	3.330	4.263	1723.3	0.1263	0.0859	0.0454	1.875	10.35	86.46	0.8270
125%	2.007	3.101	3.911	1729.6	0.1096	0.0721	0.0380	1.725	9.471	85.97	0.8121
100%	1.734	2.781	3.410	1738.6	0.0881	0.0543	0.0285	1.500	8.195	86.52	0.7824
75%	1.297	2.311	2.646	1752.4	0.0608	0.0312	0.0159	1.125	6.122	86.71	0.7047
50%	0.8802	1.921	1.971	1764.5	0.0421	0.0154	0.0068	0.7500	4.005	85.21	0.5751
25%	0.4788	1.615	1.386	1775.1	0.0297	0.0054	0.0012	0.3750	1.713	78.32	0.3722

MTDP-003-3BD18

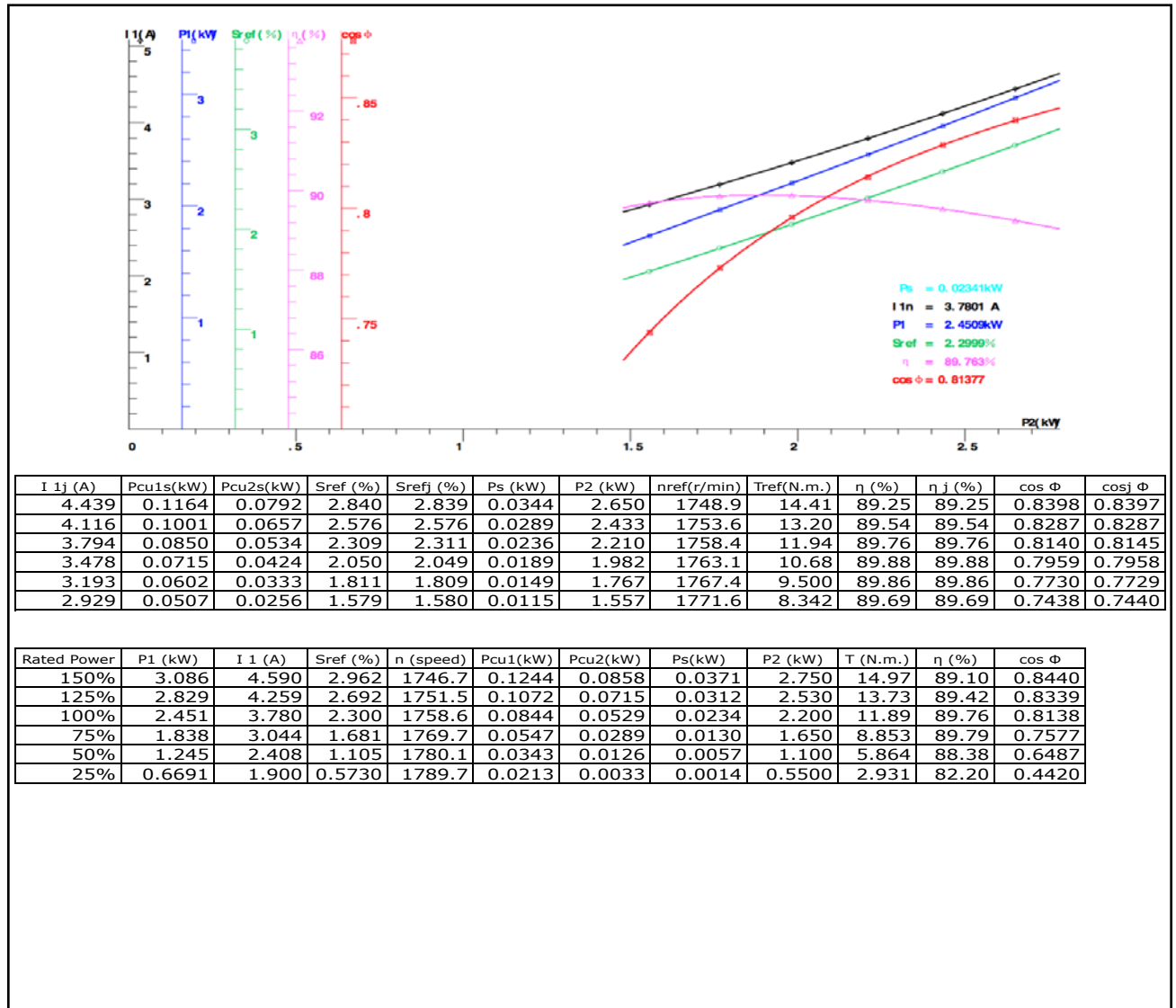

MTDP-005-3BD18

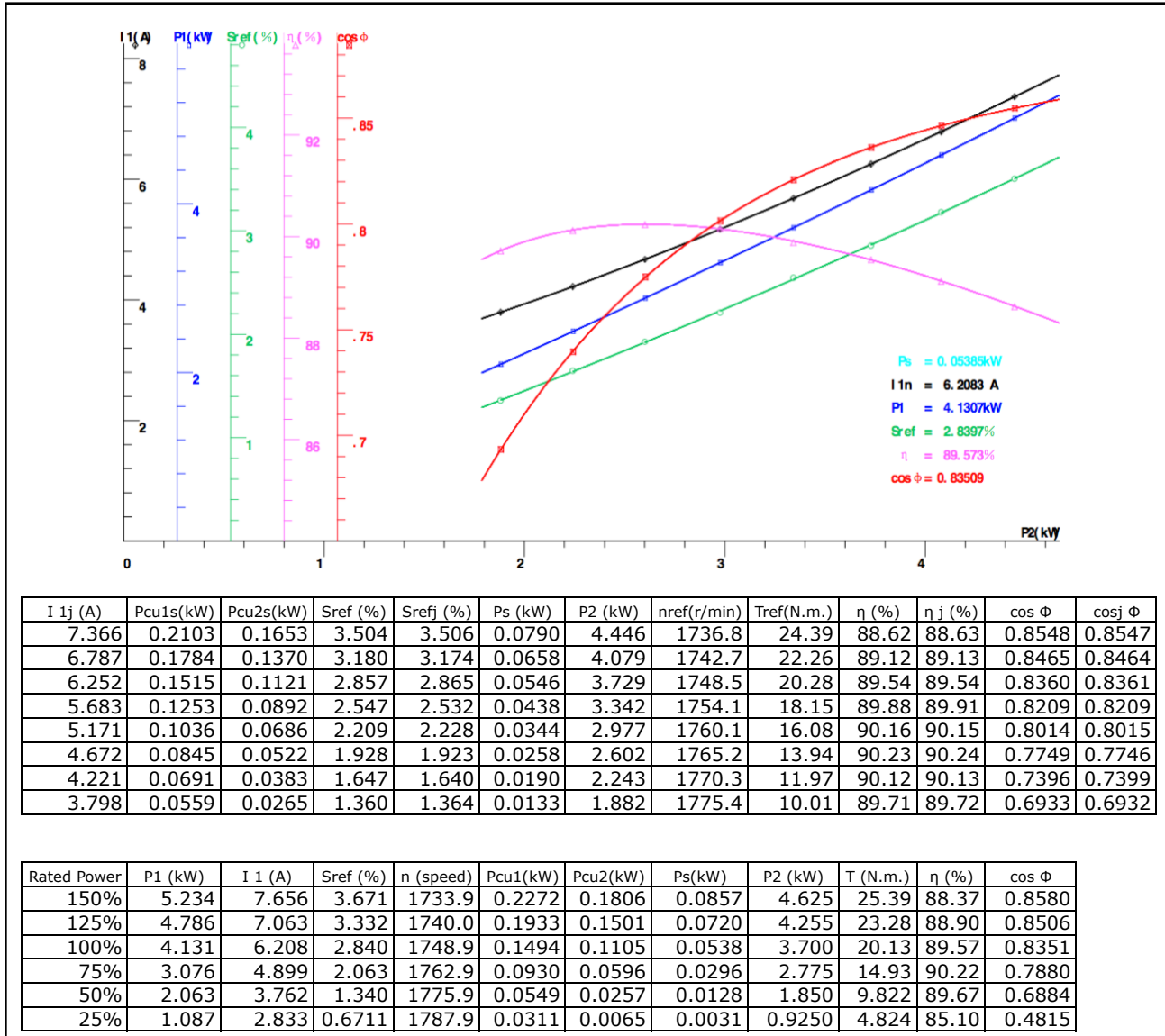

MTDP-7P5-3BD18

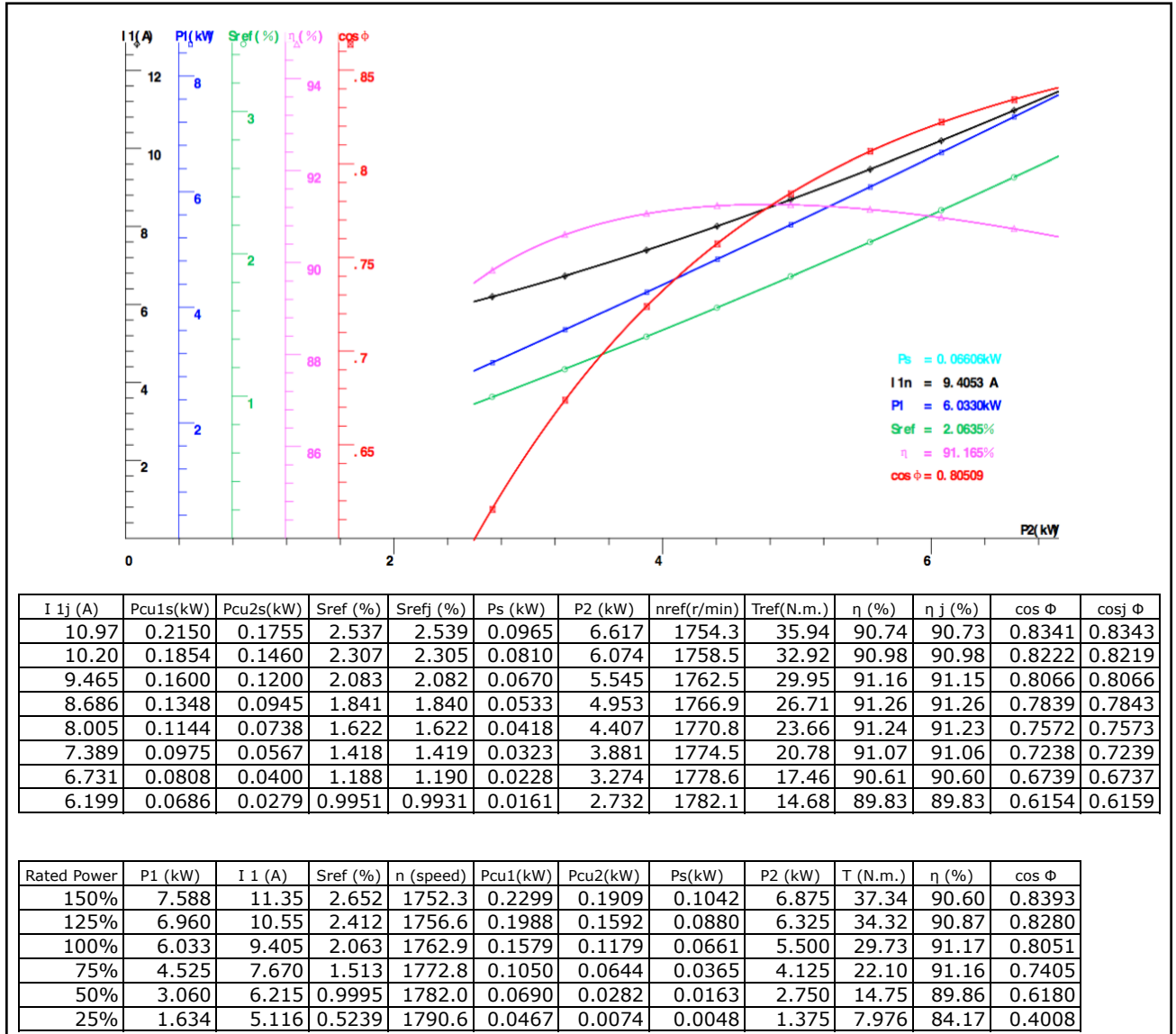

MTDP-010-3BD18

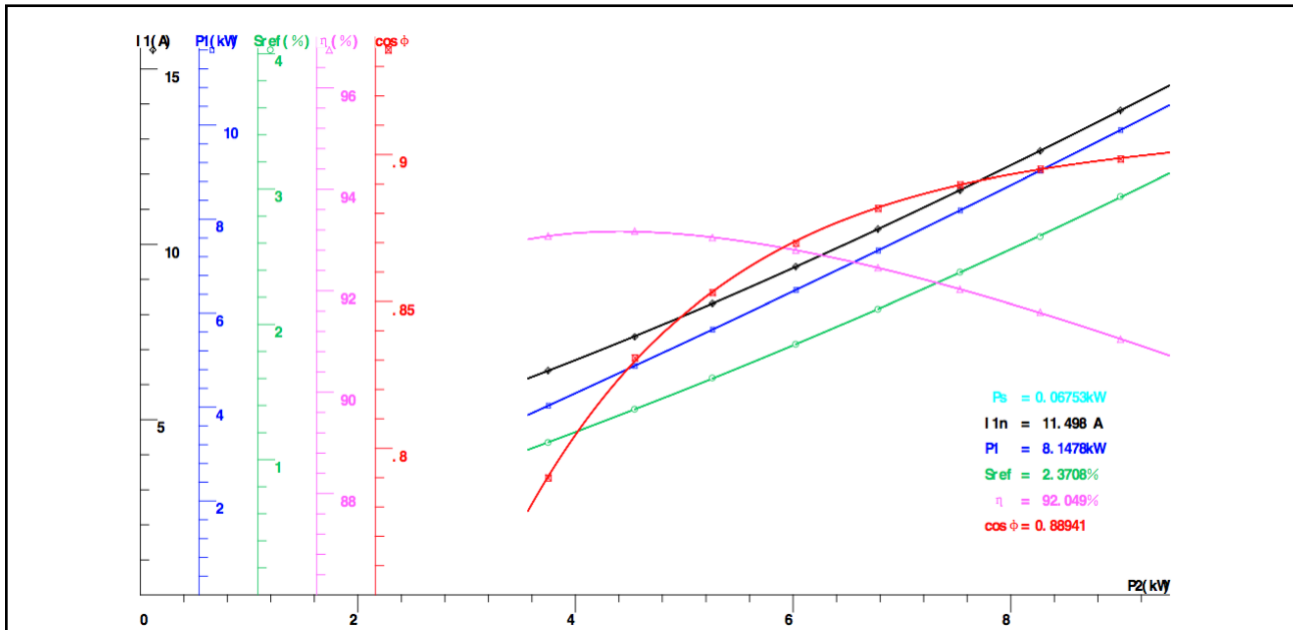

I 1j (A)	Pcu1s(kW)	Pcu2s(kW)	Sref (%)	Srefj (%)	Ps (kW)	P2 (kW)	nref(r/min)	Tref(N.m.)	η (%)	η j (%)	cos Φ	cosj Φ
13.82	0.3752	0.2770	2.944	2.938	0.0988	9.008	1747.0	49.18	91.05	91.05	0.8984	0.8988
12.67	0.3150	0.2278	2.647	2.656	0.0824	8.270	1752.3	44.91	91.58	91.56	0.8950	0.8949
11.55	0.2619	0.1863	2.385	2.383	0.0683	7.533	1757.1	40.90	92.03	92.03	0.8897	0.8897
10.43	0.2140	0.1480	2.112	2.113	0.0549	6.779	1762.0	36.65	92.45	92.45	0.8817	0.8820
9.360	0.1724	0.1150	1.853	1.853	0.0431	6.024	1766.6	32.48	92.80	92.80	0.8698	0.8705
8.311	0.1359	0.0867	1.604	1.599	0.0327	5.257	1771.1	28.28	93.05	93.05	0.8530	0.8532
7.381	0.1066	0.0639	1.372	1.372	0.0242	4.545	1775.3	24.36	93.17	93.17	0.8307	0.8296
6.397	0.0806	0.0432	1.127	1.129	0.0165	3.749	1779.7	20.08	93.08	93.08	0.7899	0.7904

Rated Power	P1 (kW)	I 1 (A)	Sref (%)	n (speed)	Pcu1(kW)	Pcu2(kW)	Ps(kW)	P2 (kW)	T (N.m.)	η (%)	cos Φ
150%	10.33	14.40	3.083	1744.5	0.4072	0.3024	0.1072	9.375	51.24	90.78	0.9004
125%	9.444	13.22	2.791	1749.8	0.3432	0.2509	0.0902	8.625	46.99	91.32	0.8969
100%	8.148	11.50	2.371	1757.3	0.2598	0.1844	0.0675	7.500	40.66	92.05	0.8894
75%	6.052	8.808	1.720	1769.0	0.1524	0.0995	0.0375	5.625	30.29	92.95	0.8624
50%	4.029	6.398	1.129	1779.7	0.0804	0.0433	0.0165	3.750	20.07	93.08	0.7904
25%	2.068	4.340	0.5989	1789.2	0.0370	0.0115	0.0041	1.875	9.979	90.68	0.5979

MTDP-015-3BD18

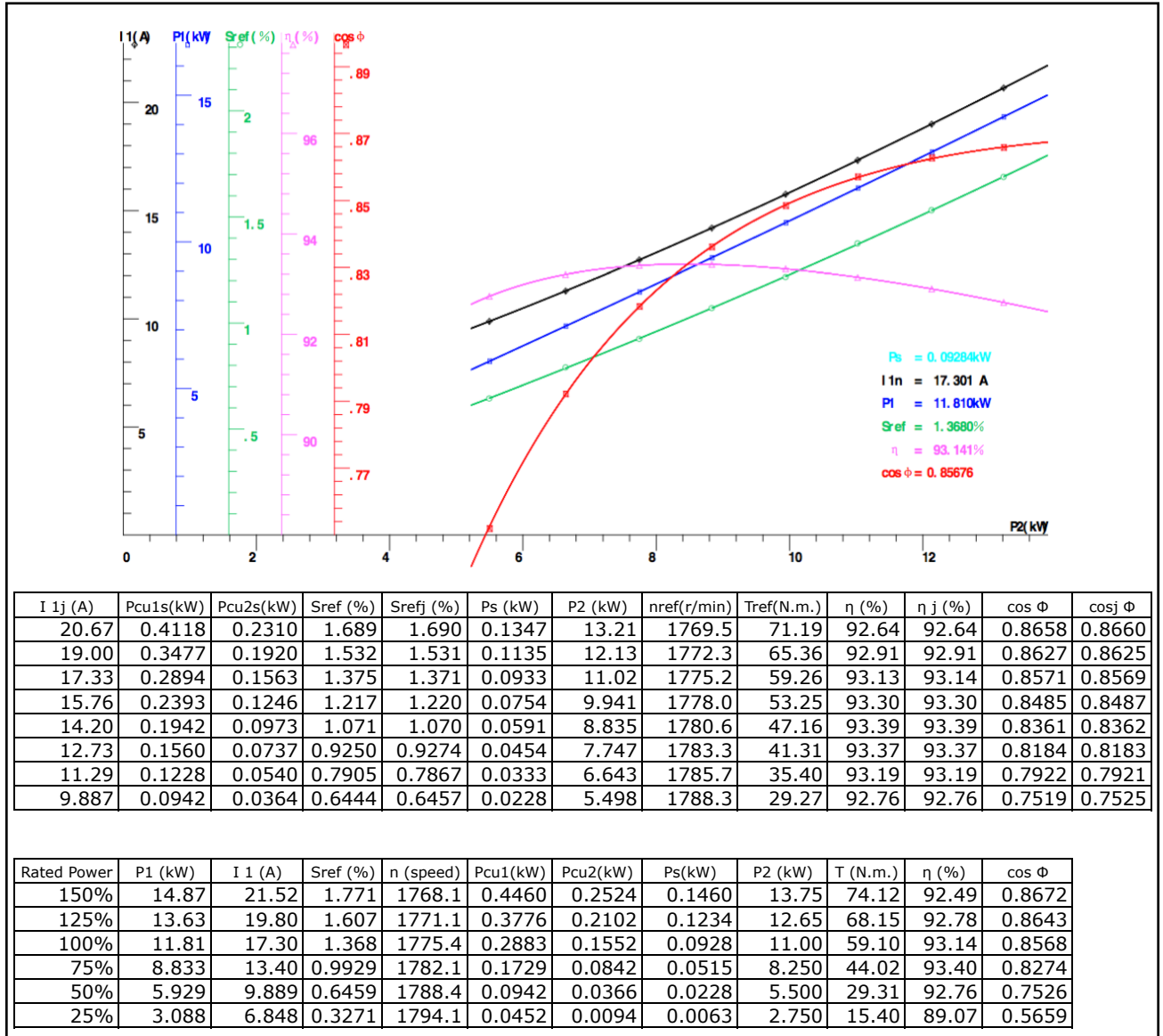

MTDP-020-3BD18

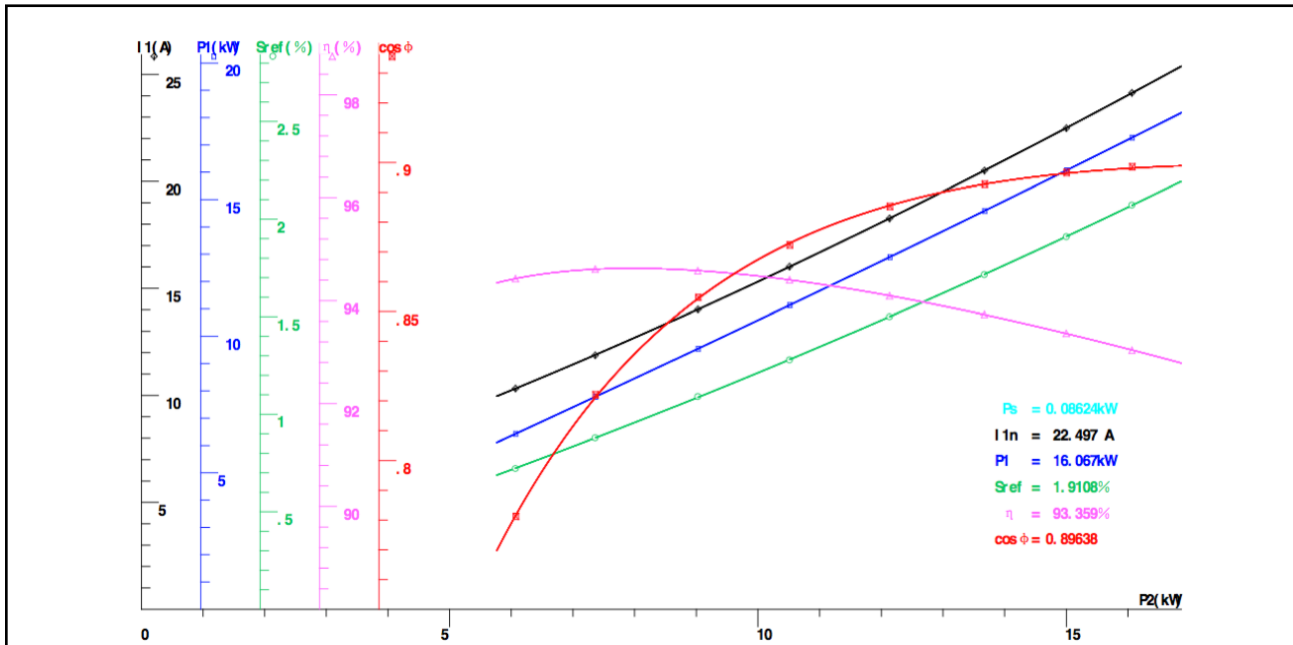

I 1j (A)	Pcu1s(kW)	Pcu2s(kW)	Sref (%)	Srefj (%)	Ps (kW)	P2 (kW)	nref(r/min)	Tref(N.m.)	η (%)	η j (%)	cos Φ	cosj Φ
24.13	0.5684	0.3432	2.072	2.070	0.0992	16.06	1762.7	86.89	93.04	93.04	0.8986	0.8981
22.50	0.4932	0.2949	1.910	1.911	0.0862	15.00	1765.6	81.02	93.37	93.36	0.8966	0.8964
20.51	0.4101	0.2409	1.715	1.717	0.0714	13.67	1769.1	73.71	93.73	93.73	0.8927	0.8927
18.27	0.3260	0.1865	1.500	1.500	0.0560	12.13	1773.0	65.28	94.10	94.10	0.8853	0.8856
16.01	0.2504	0.1374	1.278	1.280	0.0417	10.51	1777.0	56.31	94.41	94.40	0.8723	0.8729
14.02	0.1916	0.1005	1.090	1.086	0.0308	9.025	1780.4	48.39	94.58	94.58	0.8547	0.8543
11.90	0.1378	0.0661	0.8796	0.8790	0.0203	7.364	1784.2	39.34	94.61	94.61	0.8221	0.8211
10.32	0.1041	0.0447	0.7222	0.7238	0.0138	6.069	1787.0	32.37	94.43	94.43	0.7812	0.7814

Rated Power	P1 (kW)	I 1 (A)	Sref (%)	n (speed)	Pcu1(kW)	Pcu2(kW)	Ps(kW)	P2 (kW)	T (N.m.)	η (%)	cos Φ
150%	20.35	28.39	2.490	1755.2	0.7862	0.4839	0.1362	18.75	101.8	92.16	0.8996
125%	18.62	25.99	2.253	1759.4	0.6588	0.4016	0.1148	17.25	93.48	92.66	0.8991
100%	16.07	22.50	1.911	1765.6	0.4938	0.2951	0.0862	15.00	81.02	93.36	0.8964
75%	11.93	17.03	1.379	1775.2	0.2829	0.1588	0.0480	11.25	60.43	94.28	0.8795
50%	7.927	12.07	0.8957	1783.9	0.1421	0.0685	0.0211	7.500	40.08	94.62	0.8245
25%	4.027	7.690	0.4603	1791.7	0.0577	0.0176	0.0052	3.750	19.99	93.12	0.6573

MTDP-025-3BD18

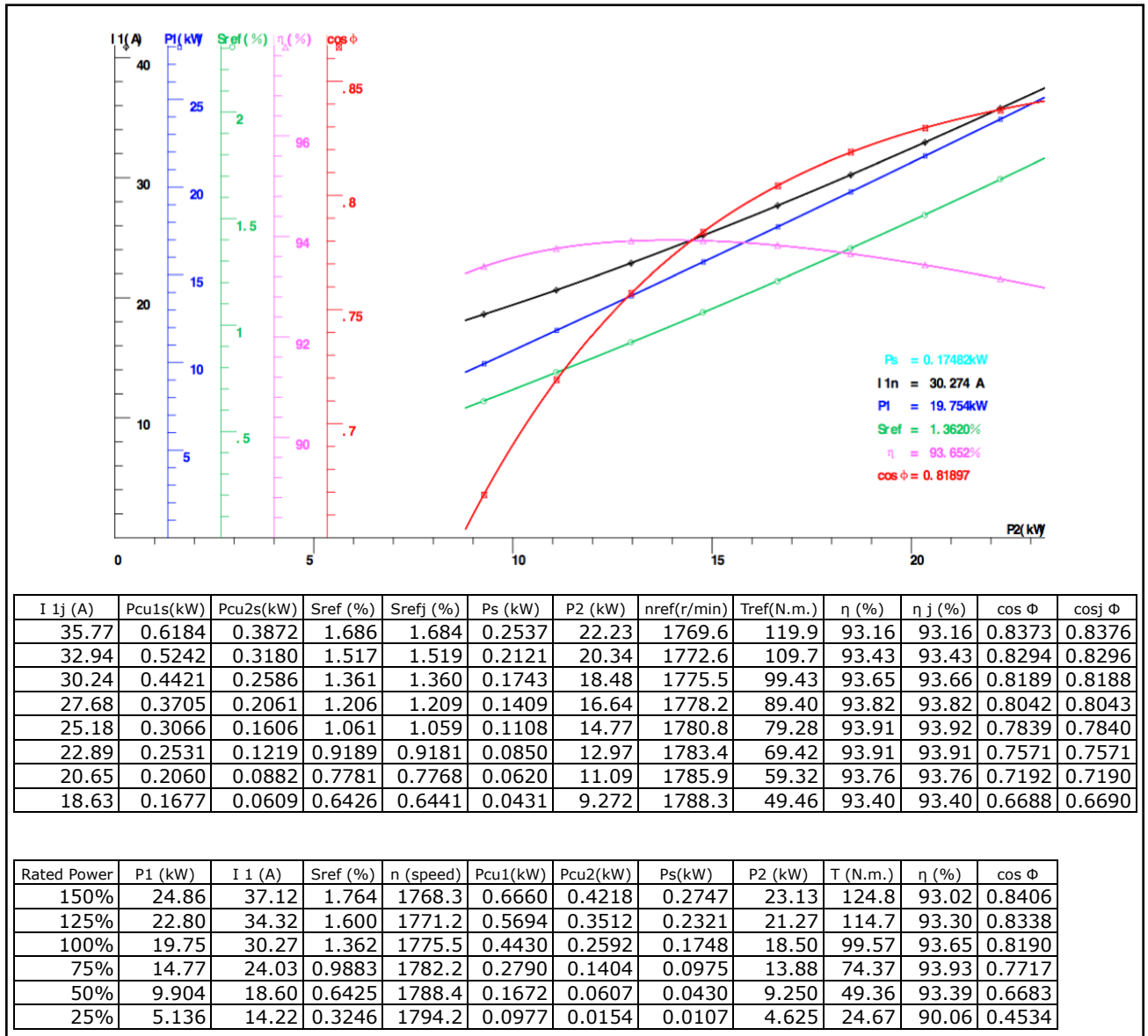

MTDP-030-3BD18

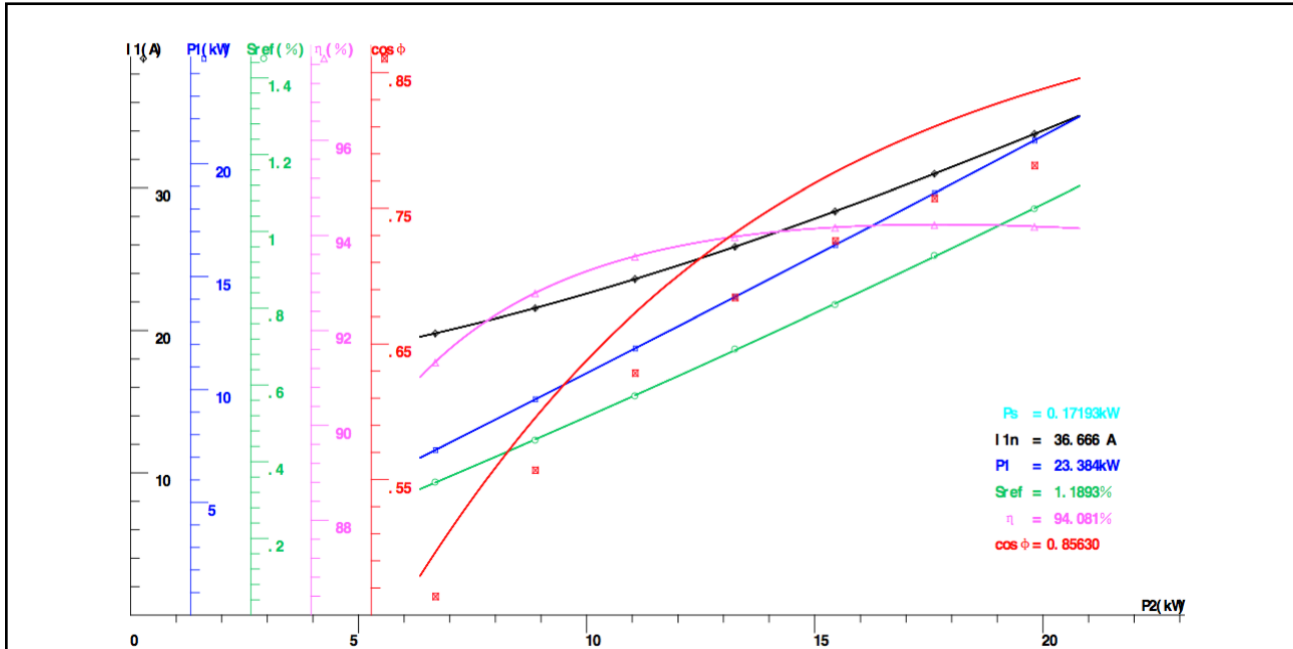

I 1j (A)	Pcu1s(kW)	Pcu2s(kW)	Sref (%)	Srefj (%)	Ps (kW)	P2 (kW)	nref(r/min)	Tref(N.m.)	η (%)	η j (%)	cos Φ	cosj Φ
33.78	0.4290	0.2148	1.059	1.060	0.1384	19.81	1780.8	106.1	94.18	94.19	0.7814	0.8360
30.99	0.3610	0.1687	0.9369	0.9341	0.1088	17.62	1783.0	94.06	94.21	94.23	0.7572	0.8101
28.36	0.3024	0.1276	0.8089	0.8117	0.0833	15.45	1785.3	82.28	94.16	94.17	0.7259	0.7766
25.87	0.2515	0.0938	0.6937	0.6906	0.0611	13.25	1787.4	70.48	93.96	93.97	0.6841	0.7317
23.60	0.2095	0.0645	0.5716	0.5729	0.0424	11.06	1789.6	58.74	93.55	93.56	0.6286	0.6727
21.56	0.1746	0.0413	0.4560	0.4578	0.0271	8.872	1791.7	46.90	92.78	92.79	0.5569	0.5954
19.80	0.1475	0.0237	0.3469	0.3456	0.0152	6.683	1793.7	35.17	91.32	91.33	0.4637	0.4961

Rated Power	P1 (kW)	I 1 (A)	Sref (%)	n (speed)	Pcu1(kW)	Pcu2(kW)	Ps(kW)	P2 (kW)	T (N.m.)	η (%)	cos Φ
150%	29.38	44.13	1.525	1772.5	0.7321	0.4320	0.2758	27.50	149.7	93.62	0.8938
125%	26.96	41.13	1.389	1775.0	0.6360	0.3612	0.2306	25.30	136.9	93.83	0.8802
100%	23.38	36.67	1.189	1778.6	0.5054	0.2682	0.1719	22.00	118.2	94.08	0.8563
75%	17.51	29.62	0.8707	1784.3	0.3298	0.1468	0.0952	16.50	87.99	94.22	0.7939
50%	11.76	23.54	0.5696	1789.7	0.2083	0.0639	0.0419	11.00	58.38	93.54	0.6708
25%	6.110	18.98	0.2861	1794.9	0.1354	0.0161	0.0102	5.500	28.74	90.01	0.4323

MTDP-040-3BD18

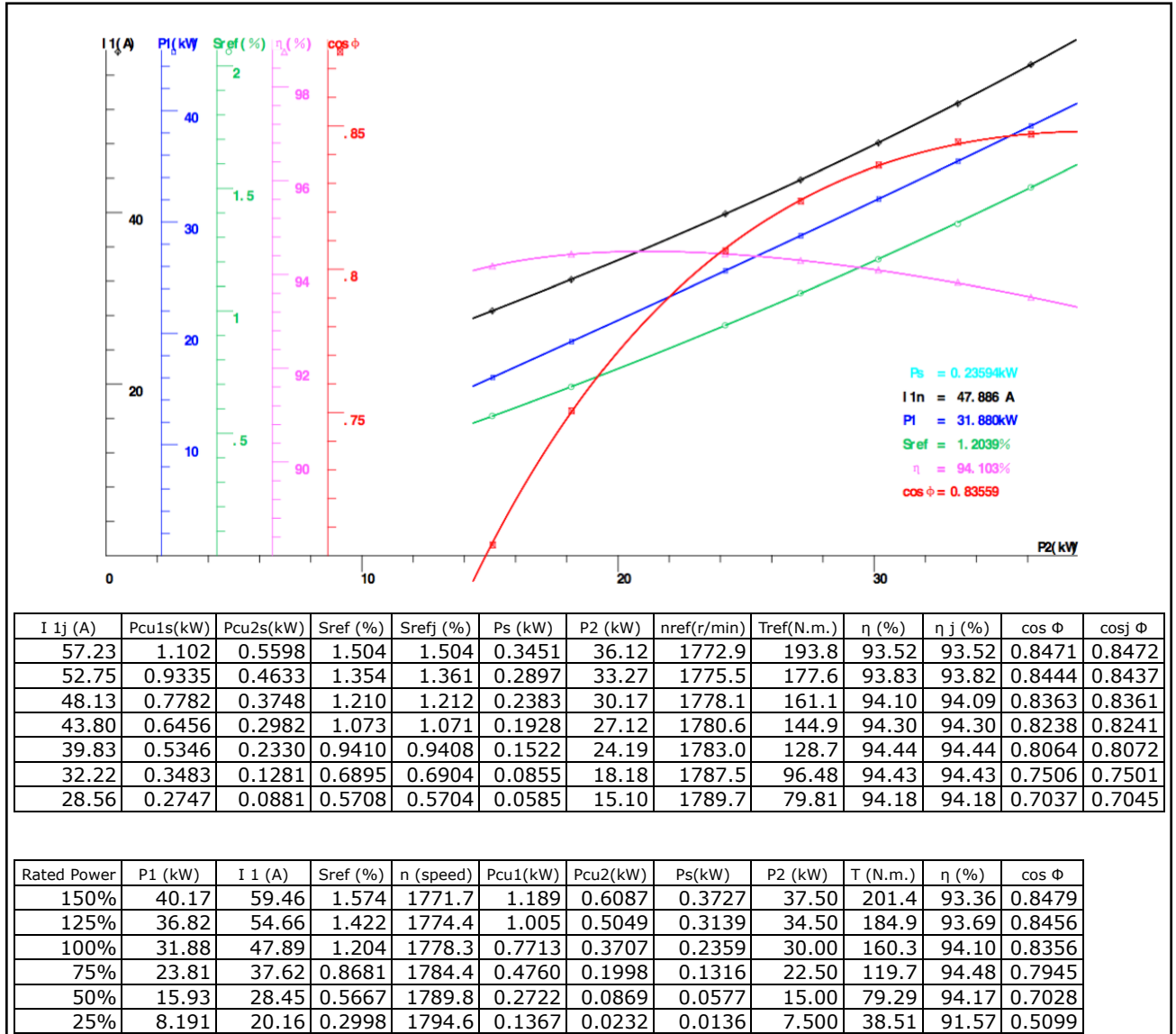

MTDP-050-3BD18

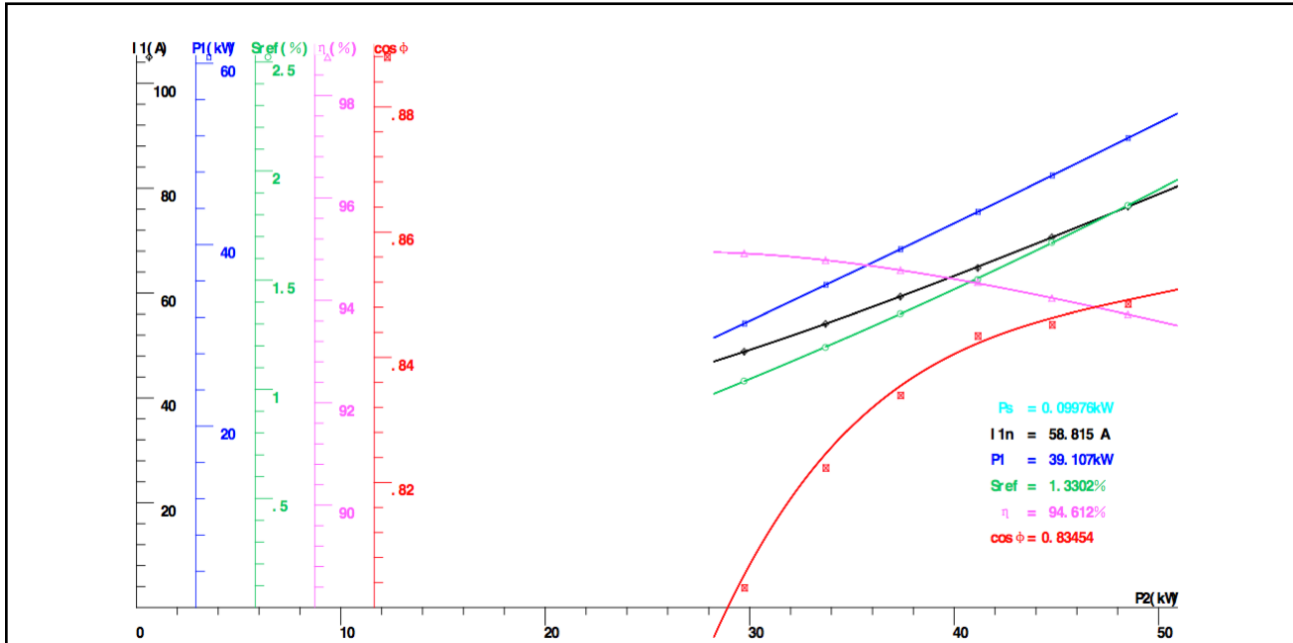

I 1j (A)	Pcu1s(kW)	Pcu2s(kW)	Sref (%)	Srefj (%)	Ps (kW)	P2 (kW)	nref(r/min)	Tref(N.m.)	η (%)	η j (%)	cos Φ	cosj Φ
76.48	1.607	0.9166	1.842	1.843	0.1743	48.50	1766.7	260.4	93.73	93.73	0.8485	0.8492
70.62	1.370	0.7670	1.673	1.671	0.1483	44.78	1769.8	240.2	94.04	94.05	0.8452	0.8463
65.01	1.153	0.6521	1.502	1.509	0.1233	41.15	1772.9	219.0	94.35	94.33	0.8434	0.8422
59.35	0.9671	0.5135	1.346	1.346	0.1018	37.36	1775.7	199.0	94.59	94.59	0.8339	0.8354
54.15	0.8059	0.4099	1.192	1.195	0.0824	33.72	1778.4	179.0	94.78	94.78	0.8223	0.8246
48.83	0.6549	0.3143	1.038	1.037	0.0641	29.73	1781.2	157.9	94.91	94.92	0.8031	0.8052

Rated Power	P1 (kW)	I 1 (A)	Sref (%)	n (speed)	Pcu1(kW)	Pcu2(kW)	Ps(kW)	P2 (kW)	T (N.m.)	η (%)	cos Φ
150%	49.24	72.93	1.738	1768.7	1.461	0.8239	0.1584	46.25	248.3	93.92	0.8475
125%	45.16	67.15	1.570	1771.7	1.239	0.6836	0.1335	42.55	227.9	94.23	0.8440
100%	39.11	58.81	1.330	1776.1	0.9503	0.5024	0.0998	37.00	197.0	94.61	0.8345
75%	29.23	46.35	0.9609	1782.7	0.5901	0.2714	0.0562	27.75	147.8	94.94	0.7915
50%	19.58	36.60	0.6305	1788.7	0.3680	0.1186	0.0292	18.50	106.5	94.47	0.6715
25%	10.13	30.65	0.3390	1793.9	0.2580	0.0321	0.0160	9.250	78.89	91.32	0.4148

MTDP-003-3BD36

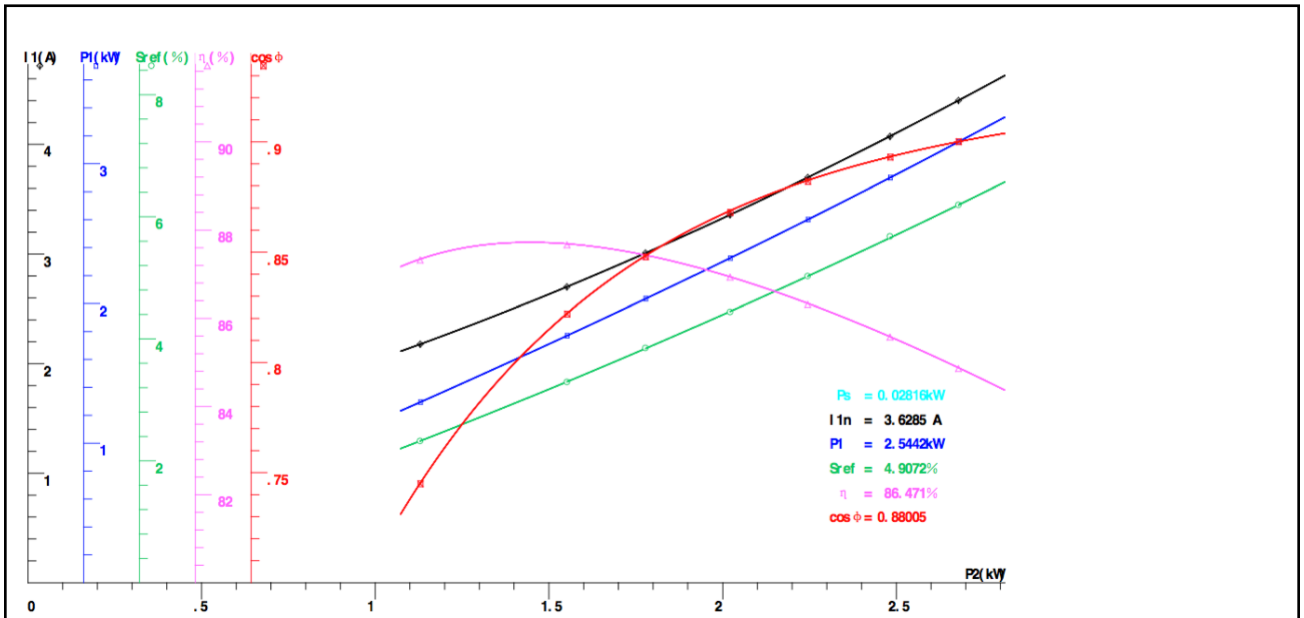

I 1j (A)	Pcu1s(kW)	Pcu2s(kW)	Sref (%)	Srefj (%)	Ps (kW)	P2 (kW)	nref(r/min)	Tref(N.m.)	η (%)	η j (%)	cos Φ	cosj Φ
4.401	0.1697	0.1817	6.194	6.194	0.0431	2.679	3376.8	7.503	84.86	84.88	0.9001	0.9000
4.074	0.1454	0.1533	5.678	5.654	0.0356	2.482	3395.4	6.822	85.57	85.58	0.8930	0.8932
3.698	0.1198	0.1220	5.026	5.025	0.0296	2.245	3418.9	6.217	86.31	86.34	0.8820	0.8825
3.359	0.0988	0.0964	4.439	4.448	0.0233	2.021	3440.0	5.516	86.93	86.94	0.8680	0.8688
3.009	0.0794	0.0731	3.851	3.842	0.0178	1.778	3461.2	4.816	87.40	87.43	0.8478	0.8484
2.702	0.0639	0.0543	3.293	3.296	0.0133	1.552	3481.3	4.176	87.67	87.69	0.8219	0.8222
2.178	0.0416	0.0278	2.326	2.326	0.0067	1.130	3516.1	2.968	87.32	87.34	0.7449	0.7452

Rated Power	P1 (kW)	I 1 (A)	Sref (%)	n (speed)	Pcu1(kW)	Pcu2(kW)	Ps(kW)	P2 (kW)	T (N.m.)	η (%)	cos Φ
150%	3.250	4.522	6.392	3369.9	0.1791	0.1929	0.0456	2.750	7.721	84.61	0.9021
125%	2.962	4.154	5.785	3391.7	0.1511	0.1595	0.0381	2.530	7.056	85.42	0.8950
100%	2.544	3.628	4.907	3423.3	0.1153	0.1165	0.0282	2.200	6.065	86.47	0.8801
75%	1.883	2.833	3.530	3472.9	0.0703	0.0620	0.0151	1.650	4.448	87.61	0.8345
50%	1.261	2.144	2.261	3518.6	0.0403	0.0263	0.0064	1.100	2.888	87.25	0.7380
25%	0.6691	1.574	1.099	3560.5	0.0217	0.0065	0.0015	0.5500	1.408	82.20	0.5337

MTDP-005-3BD36

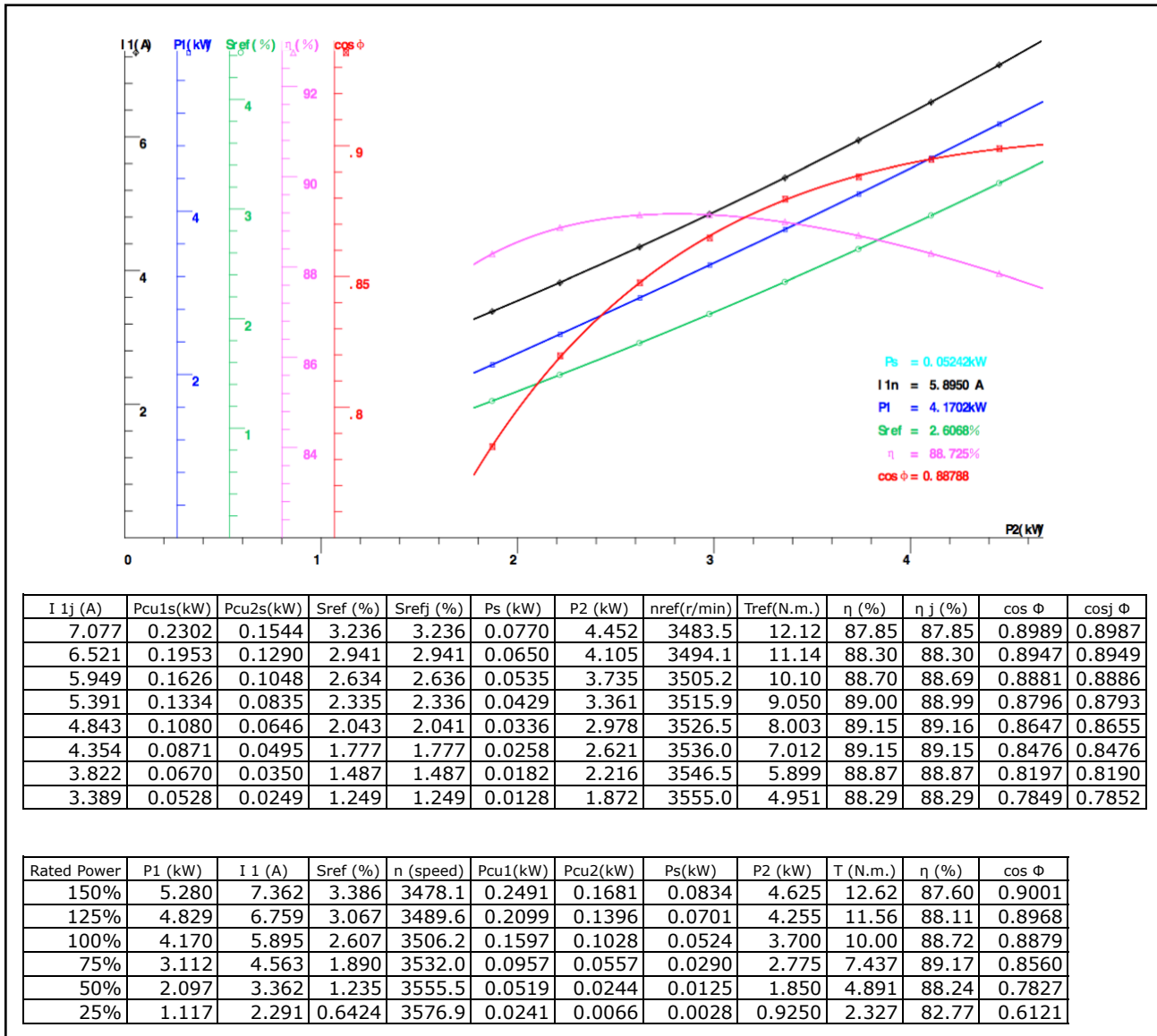

MTDP-7P5-3BD36

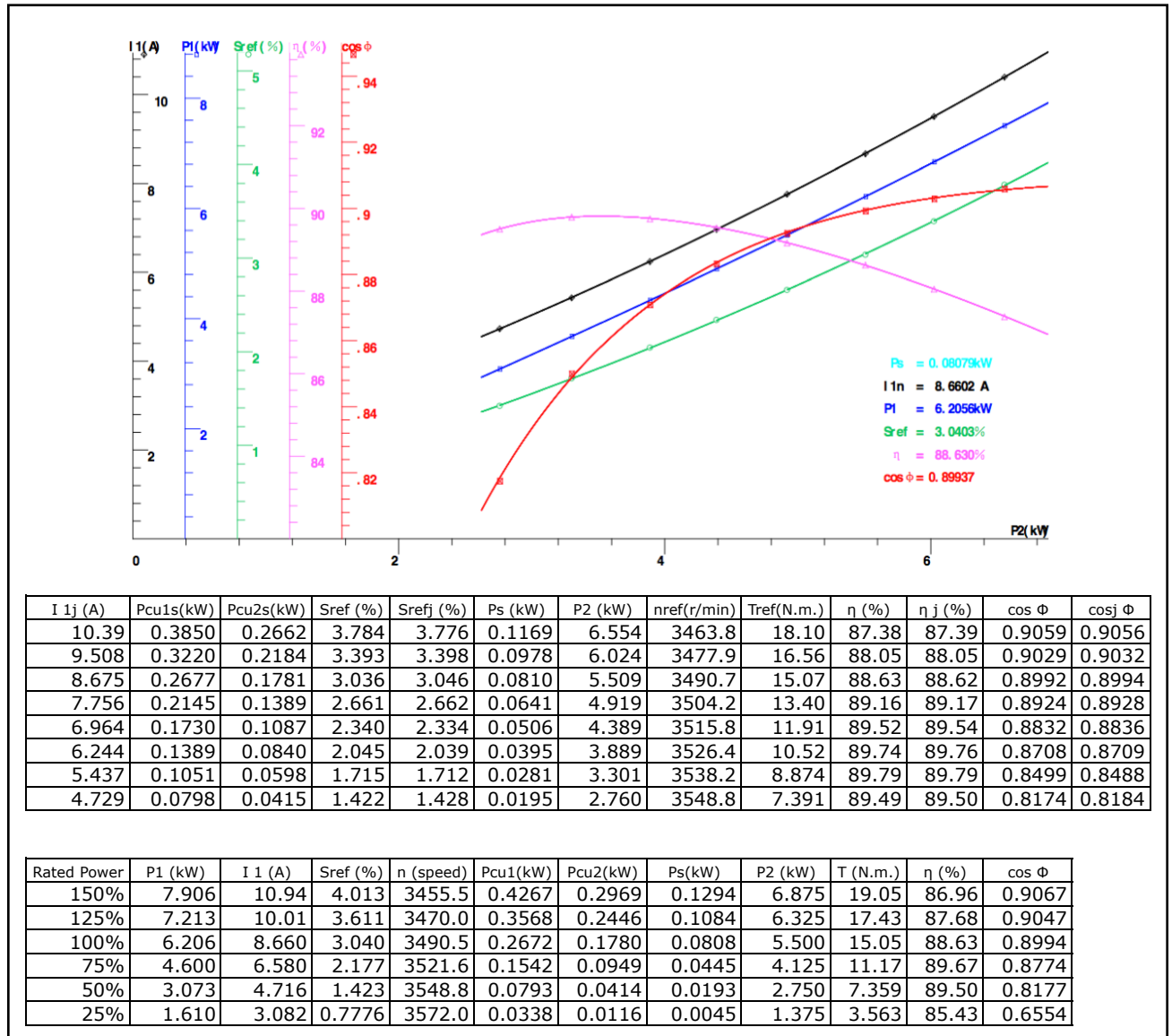

PERFORMANCE CURVES FOR MTRP MOTORS

MTRP-001-3BD18

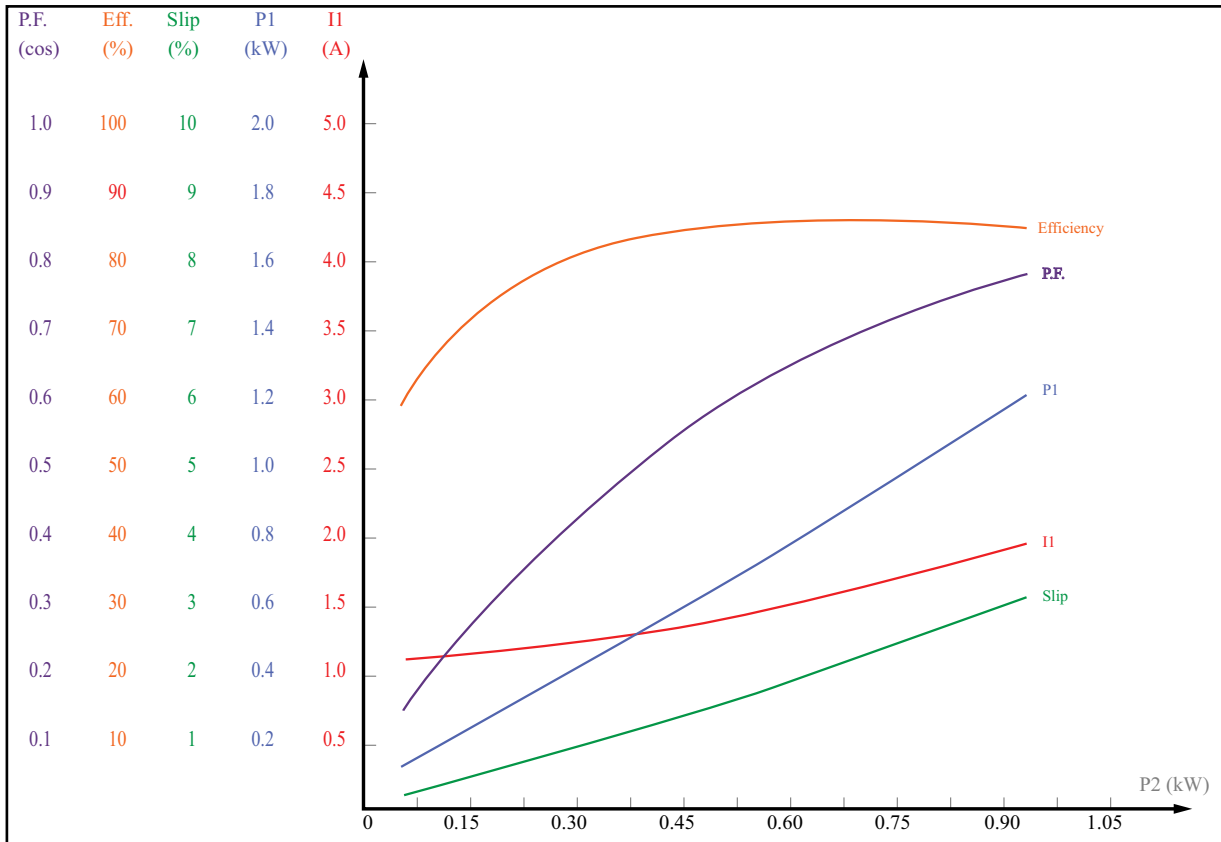

Performance Data - MTRP-001-3BD18							
P2 (kW)	U (V)	I1 (A)	P1 (kW)	Torque (N·m)	Speed (RPM)	EFF (%)	P.F. (cos)
0.2011	456.5	1.143	0.2726	1.045	1789.9	73.76	0.299
0.3868	453.1	1.251	0.4689	2.035	1780.7	82.49	0.470
0.5777	449.7	1.410	0.6782	3.065	1770.9	85.18	0.603
0.7636	445.7	1.607	0.8903	4.105	1760.5	85.76	0.696
0.8470	444.5	1.707	0.9882	4.565	1756.0	85.71	0.727
0.9483	443.2	1.834	1.1101	5.145	1749.4	85.42	0.759

Load Performance Data - MTRP-001-3BD18						
Load (%)	Current (A)	Input (kW)	Slip (%)	EFF (%)	P.F. (cos)	Output (kW)
25	1.138	0.2585	0.541	72.74	0.285	0.1875
50	1.242	0.4563	1.040	82.14	0.460	0.3750
75	1.396	0.6612	1.570	85.11	0.594	0.5625
100	1.592	0.8744	2.142	85.73	0.690	0.7500
125	1.821	1.0970	2.770	85.48	0.755	0.9375

MTRP-001-3BD36

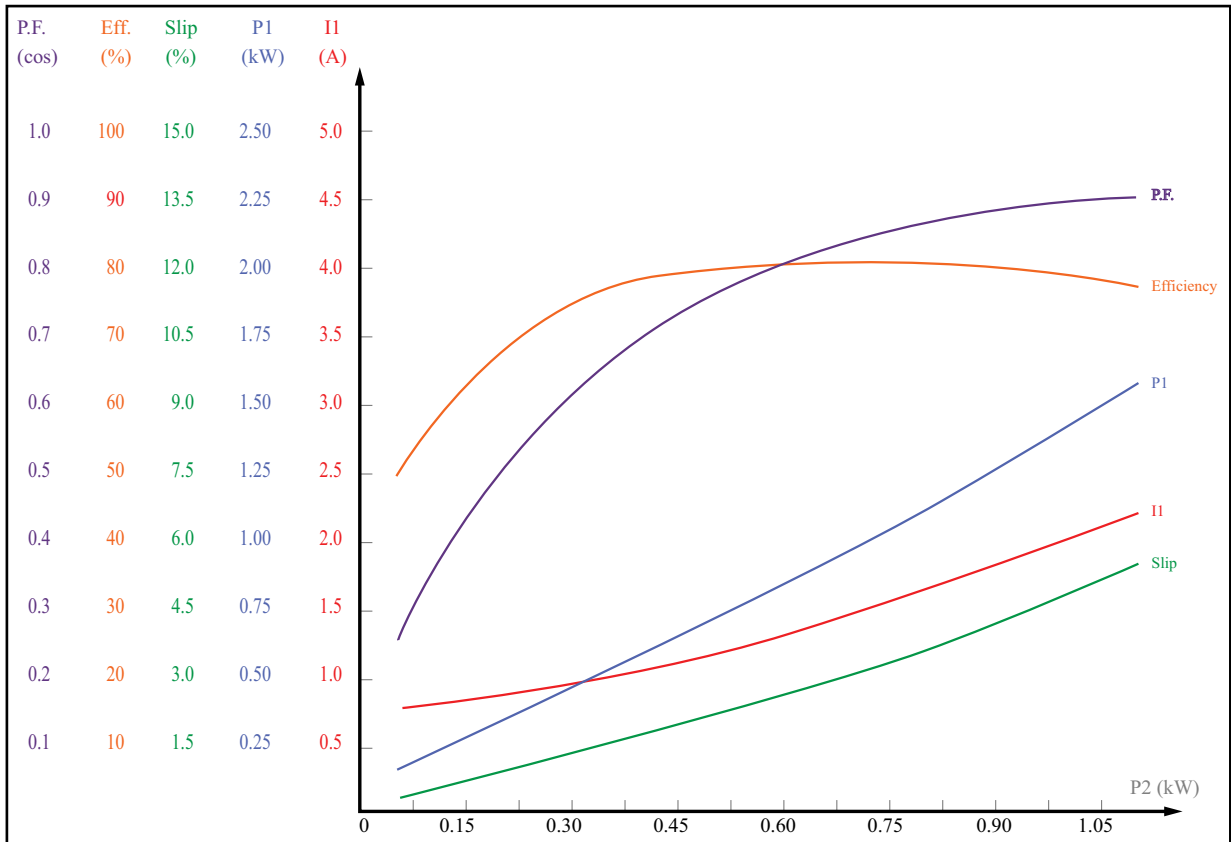

Performance Data - MTRP-001-3BD36							
P2 (kW)	U (V)	I1 (A)	P1 (kW)	Torque (N·m)	Speed (RPM)	EFF (%)	P.F. (cos)
0.2011	452.0	0.827	0.3058	0.527	3571.5	65.77	0.464
0.3880	446.7	0.973	0.5079	1.037	3547.3	76.40	0.654
0.5748	440.4	1.175	0.7204	1.557	3521.2	79.79	0.768
0.7628	434.2	1.424	0.9468	2.077	3493.5	80.56	0.833
0.9527	426.9	1.713	1.1912	2.617	3461.2	79.98	0.872
1.1374	419.5	2.035	1.4490	3.167	3423.7	78.49	0.894

Load Performance Data - MTRP-001-3BD36						
Load (%)	Current (A)	Input (kW)	Slip (%)	EFF (%)	P.F. (cos)	Output (kW)
25	0.817	0.2912	0.738	64.56	0.446	0.1875
50	0.963	0.4938	1.428	75.93	0.644	0.3750
75	1.160	0.7059	2.131	79.77	0.762	0.5625
100	1.404	0.9306	2.899	80.45	0.830	0.7500
125	1.690	1.1713	3.784	80.11	0.870	0.9375

MTRP-002-3BD18

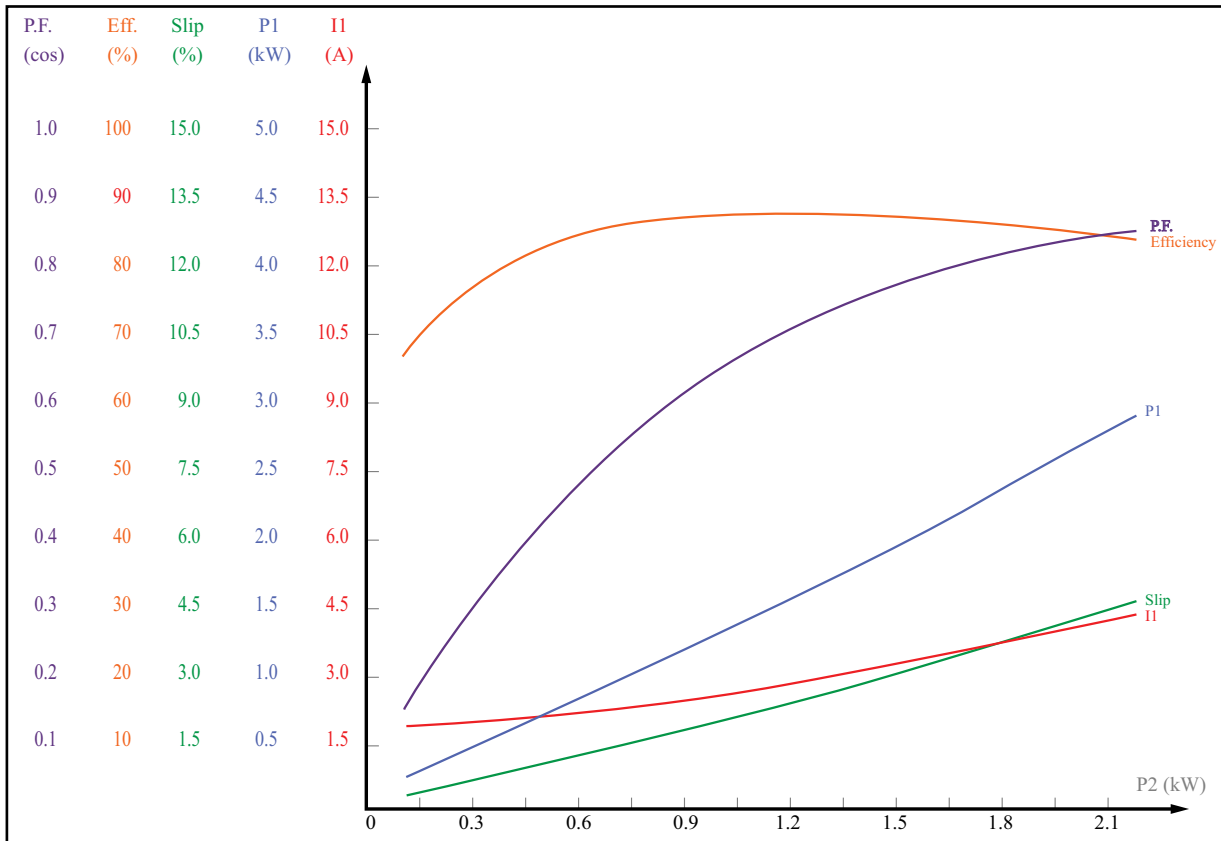

Performance Data - MTRP-002-3BD18							
P2 (kW)	U (V)	I1 (A)	P1 (kW)	Torque (N·m)	Speed (RPM)	EFF (%)	P.F. (cos)
0.3884	456.5	1.920	0.4977	2.031	1788.3	78.03	0.325
0.7659	453.7	2.171	0.8982	4.051	1777.0	85.27	0.519
1.1395	450.2	2.520	1.3113	6.111	1764.7	86.90	0.653
1.5144	447.9	2.953	1.7434	8.191	1752.4	86.86	0.740
1.8893	443.6	3.457	2.1959	10.311	1738.8	86.04	0.798
2.2565	440.6	4.007	2.6628	12.471	1724.4	84.74	0.834

Load Performance Data - MTRP-002-3BD18						
Load (%)	Current (A)	Input (kW)	Slip (%)	EFF (%)	P.F. (cos)	Output (kW)
25	1.913	0.4837	0.657	77.63	0.317	0.3750
50	2.159	0.8814	1.255	85.06	0.513	0.7500
75	2.504	1.2947	1.911	86.97	0.648	1.1250
100	2.935	1.7263	2.621	86.79	0.738	1.5000
125	3.437	2.1786	3.379	86.12	0.795	1.8750

MTRP-002-3BD36

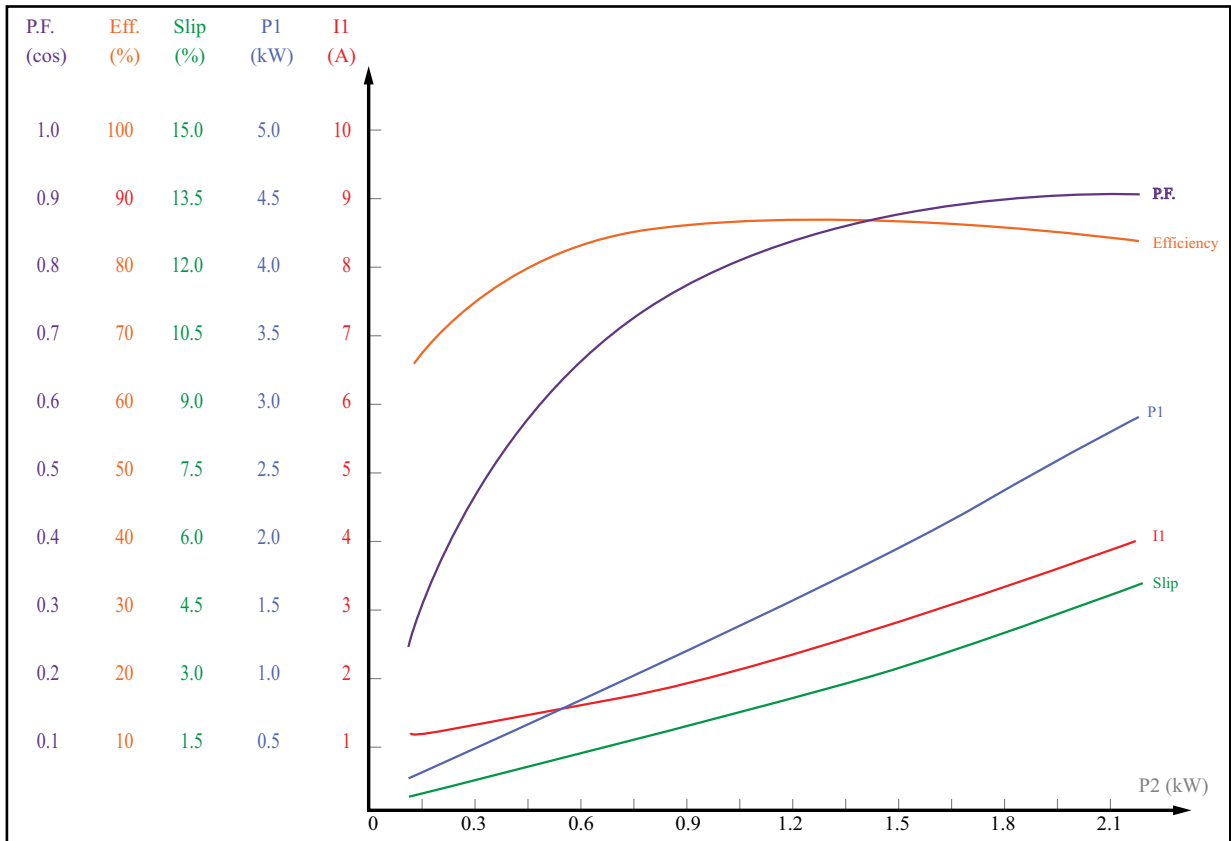

Performance Data - MTRP-002-3BD36							
P2 (kW)	U (V)	I1 (A)	P1 (kW)	Torque (N·m)	Speed (RPM)	EFF (%)	P.F. (cos)
0.3901	455.7	1.301	0.5100	1.050	3573.5	76.49	0.492
0.7636	453.1	1.625	0.9066	2.070	3549.8	84.23	0.699
1.1381	449.1	2.059	1.3200	3.100	3524.8	86.22	0.804
1.5113	445.8	2.558	1.7497	4.140	3497.9	86.38	0.857
1.8859	441.3	3.116	2.2030	5.210	3468.4	85.61	0.887
2.2572	437.9	3.714	2.6759	6.290	3437.4	84.35	0.903

Load Performance Data - MTRP-002-3BD36						
Load (%)	Current (A)	Input (kW)	Slip (%)	EFF (%)	P.F. (cos)	Output (kW)
25	1.289	0.4943	0.712	76.00	0.481	0.3750
50	1.615	0.8919	1.368	84.03	0.693	0.7500
75	2.039	1.3050	2.056	86.29	0.802	1.1250
100	2.541	1.7366	2.798	86.28	0.856	1.5000
125	3.102	2.1894	3.617	85.69	0.887	1.8750

MTRP-003-3BD36

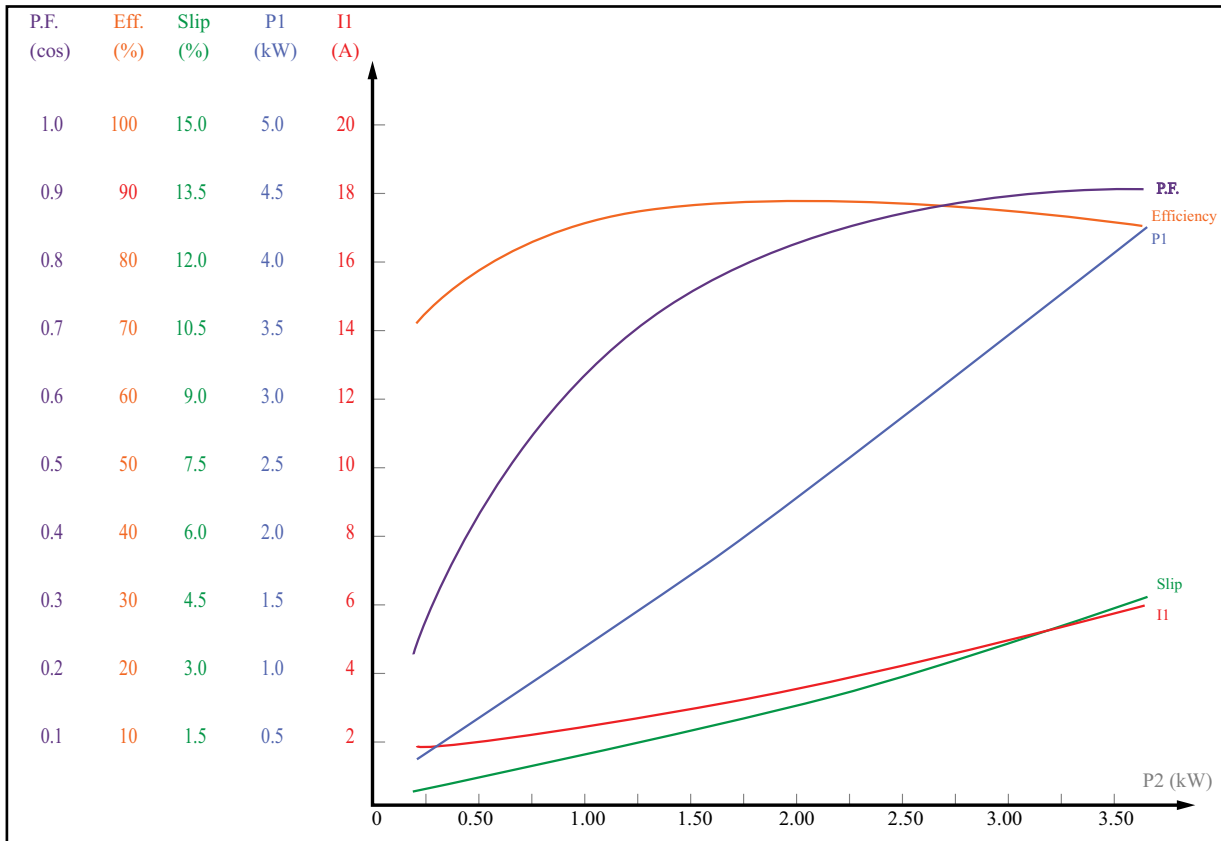

Performance Data - MTRP-003-3BD36							
P2 (kW)	U (V)	I1 (A)	P1 (kW)	Torque (N·m)	Speed (RPM)	EFF (%)	P.F. (cos)
0.5814	455.8	1.974	0.7255	1.539	3576.6	80.14	0.462
1.1407	453.5	2.445	1.3155	3.049	3555.0	86.72	0.675
1.6975	450.0	3.064	1.9239	4.569	3532.0	88.23	0.788
2.2630	446.4	3.797	2.5673	6.139	3507.2	88.15	0.848
2.8224	442.9	4.604	3.2325	7.729	3480.0	87.31	0.880
3.3716	438.7	5.473	3.9200	9.329	3450.6	86.01	0.899

Load Performance Data - MTRP-003-3BD36						
Load (%)	Current (A)	Input (kW)	Slip (%)	EFF (%)	P.F. (cos)	Output (kW)
25	1.957	0.7031	0.627	79.75	0.451	0.5600
50	2.430	1.2934	1.197	86.54	0.669	1.1200
75	3.039	1.9044	1.819	88.30	0.785	1.6800
100	3.762	2.5402	2.507	88.09	0.846	2.2400
125	4.575	3.2056	3.277	87.38	0.880	2.8000

MTRP-1P5-3BD18

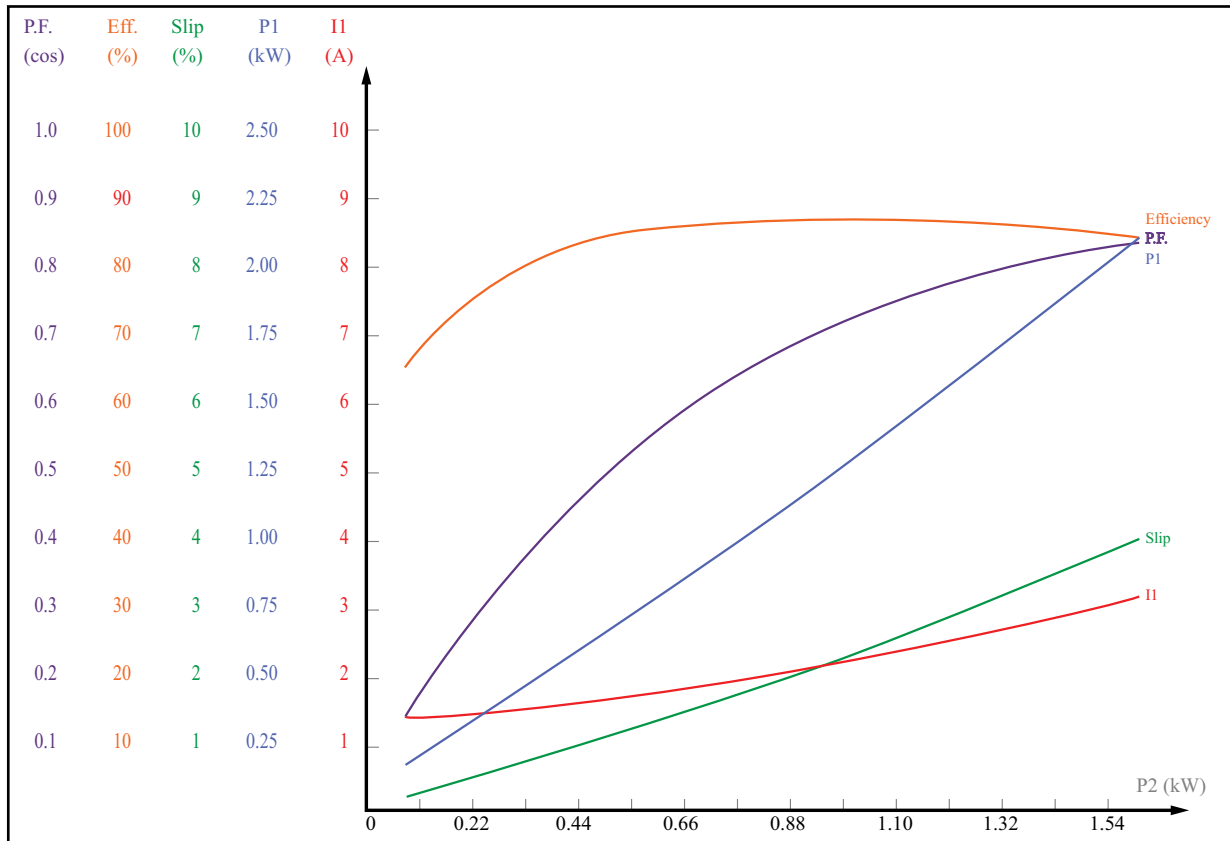

Performance Data - MTRP-1P5-3BD18							
P2 (kW)	U (V)	I1 (A)	P1 (kW)	Torque (N·m)	Speed (RPM)	EFF (%)	P.F. (cos)
0.2882	457.0	1.486	0.3750	1.485	1789.6	76.86	0.317
0.5680	454.9	1.666	0.6709	2.985	1779.7	84.67	0.505
0.8415	452.4	1.917	0.9713	4.475	1769.4	86.63	0.635
1.1180	449.3	2.232	1.2873	5.995	1758.2	86.85	0.723
1.3873	446.8	2.581	1.6073	7.525	1747.0	86.31	0.780
1.6625	443.5	2.983	1.9508	9.105	1733.6	85.22	0.820

Load Performance Data - MTRP-1P5-3BD18						
Load (%)	Current (A)	Input (kW)	Slip (%)	EFF (%)	P.F. (cos)	Output (kW)
25	1.479	0.3612	0.545	76.28	0.306	0.2750
50	1.653	0.6517	1.095	84.33	0.495	0.5500
75	1.900	0.9528	1.673	86.68	0.628	0.8250
100	2.208	1.2660	2.287	86.79	0.719	1.1000
125	2.566	1.5927	2.943	86.37	0.778	1.3750

MTRP-1P5-3BD36

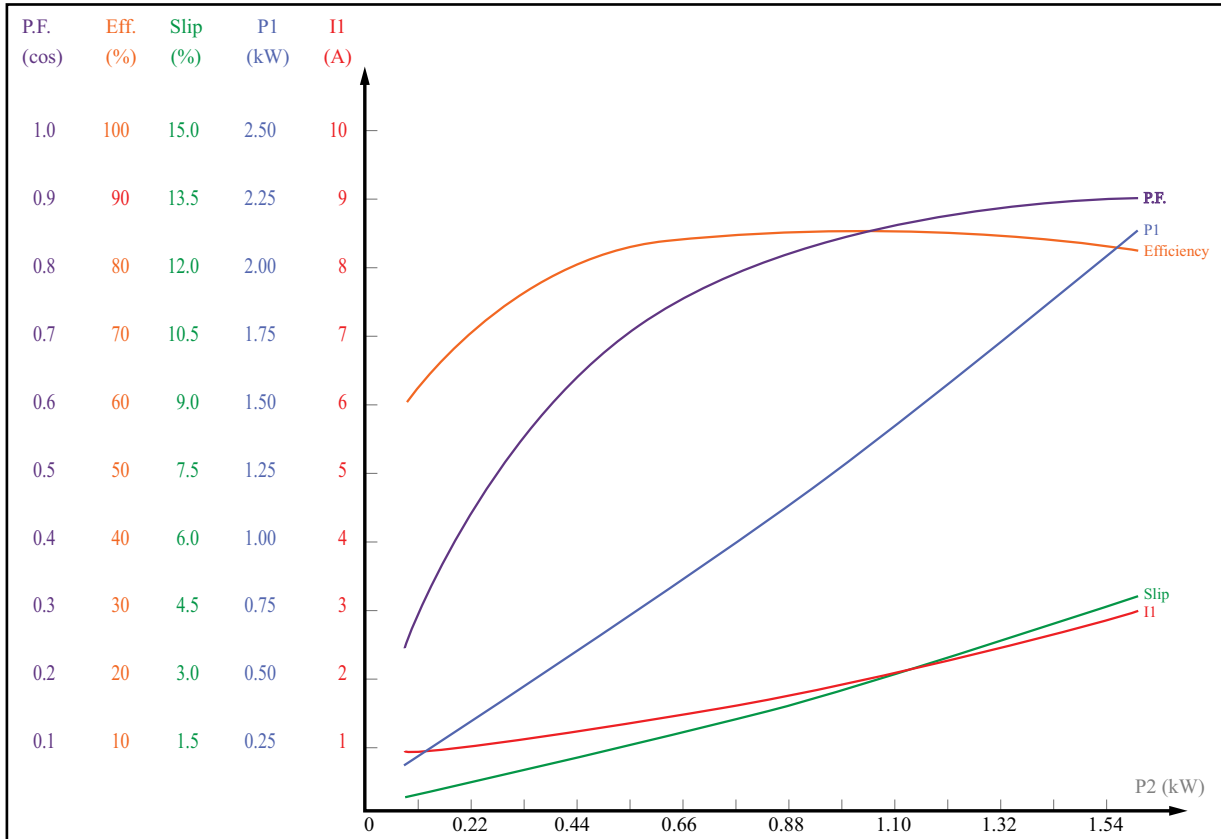

Performance Data - MTRP-1P5-3BD36							
P2 (kW)	U (V)	I1 (A)	P1 (kW)	Torque (N·m)	Speed (RPM)	EFF (%)	P.F. (cos)
0.2892	455.7	1.028	0.3944	0.776	3572.9	73.34	0.481
0.5620	452.6	1.255	0.6837	1.516	3551.4	82.20	0.683
0.8366	448.9	1.562	0.9867	2.266	3527.3	84.78	0.792
1.1114	445.2	1.928	1.3034	3.036	3501.2	85.27	0.848
1.3898	441.0	2.338	1.6387	3.816	3472.9	84.81	0.879
1.6550	437.2	2.766	1.9768	4.606	3443.0	83.72	0.897

Load Performance Data - MTRP-1P5-3BD36						
Load (%)	Current (A)	Input (kW)	Slip (%)	EFF (%)	P.F. (cos)	Output (kW)
25	1.018	0.3794	0.715	72.64	0.467	0.2750
50	1.245	0.6710	1.340	81.91	0.676	0.5500
75	1.547	0.9736	1.995	84.83	0.789	0.8250
100	1.910	1.2895	2.700	85.20	0.847	1.1000
125	2.318	1.6209	3.475	84.87	0.878	1.3750

SPEED/TORQUE CURVES FOR MTCP2 MOTORS (1800 RPM)

MTCP2-001-3BD18(C)

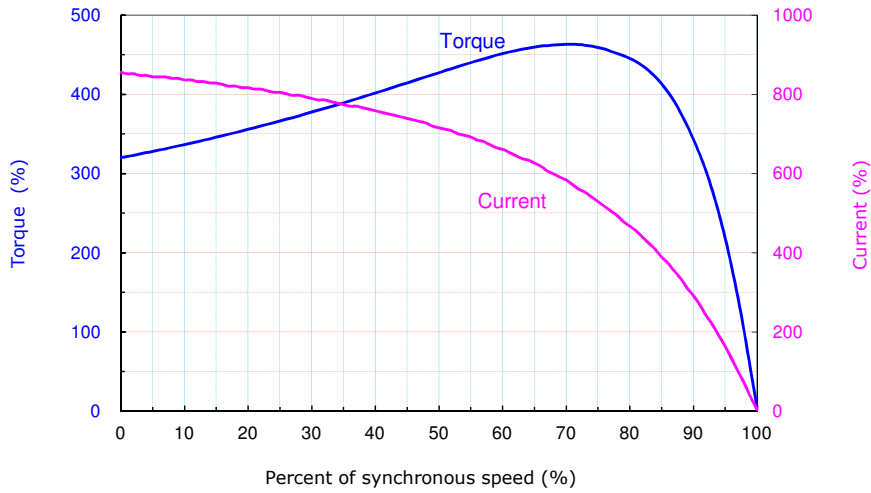

Rated Torque = 2.99 Lb.ft Synchronous Speed = 1800 r/min Rated Current = 1.63A(460V)

MTCP2-1P5-3BD18(C)

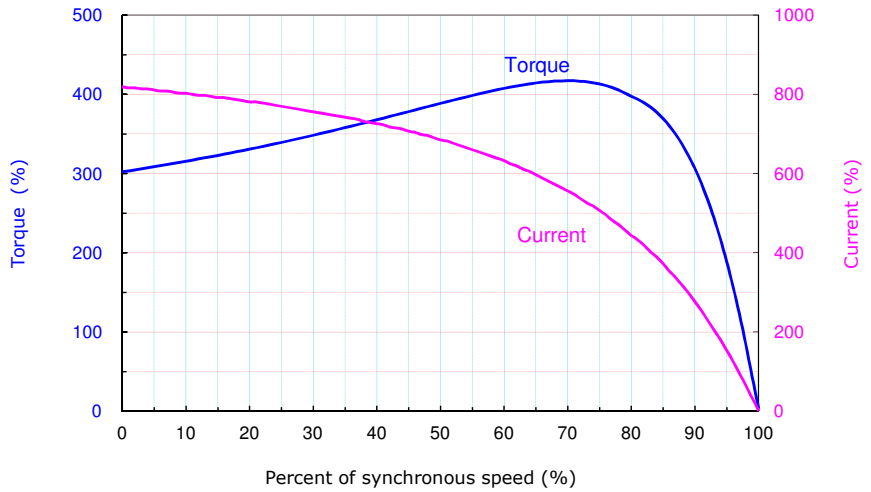

Rated Torque = 4.49 Lb.ft Synchronous Speed = 1800 r/min Rated Current = 2.22A(460V)

MTCP2-002-3BD18(C)

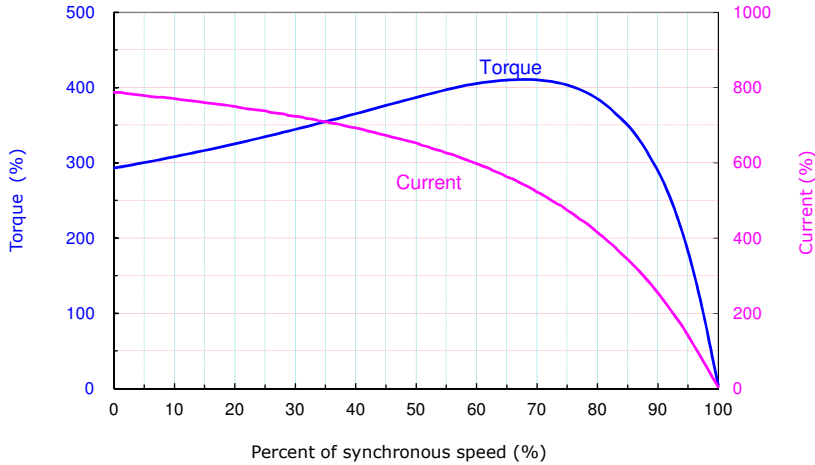

Rated Torque = 5.98 Lb.ft Synchronous Speed = 1800 r/min Rated Current = 2.97A(460V)

MTCP2-003-3BD18(C)

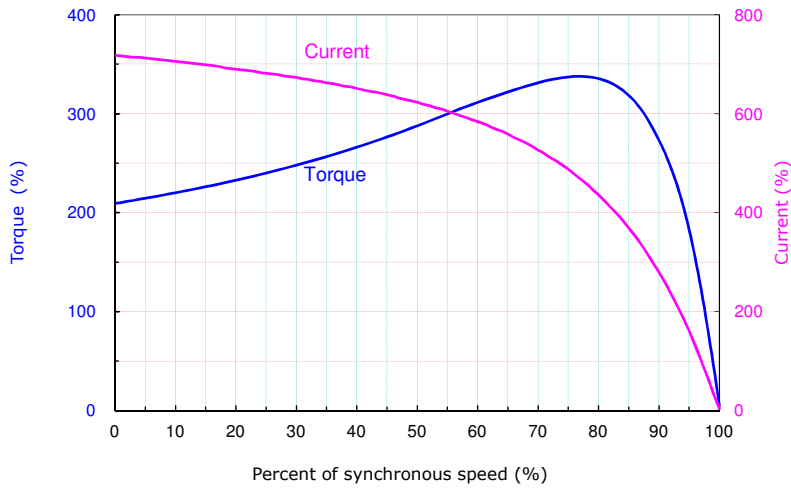

Rated Torque = 8.97 Lb.ft Synchronous Speed = 1800 r/min Rated Current = 4.08A(460V)

MTCP2-005-3BD18(C)

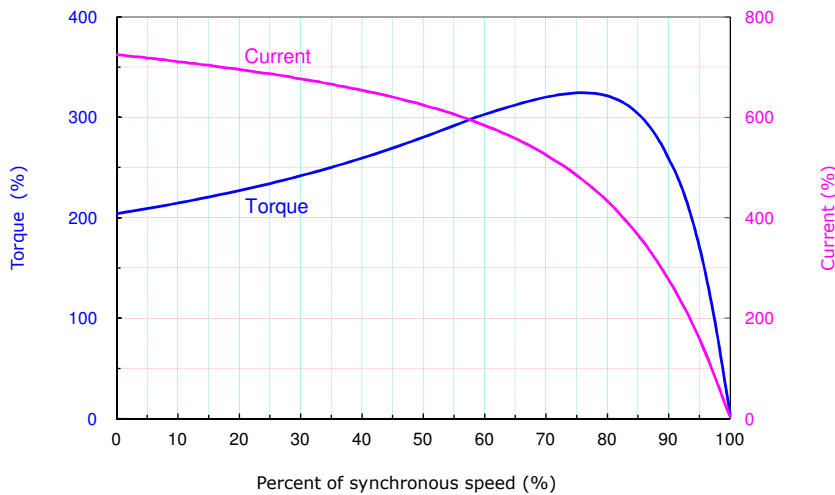

Rated Torque = 15 Lb.ft Synchronous Speed = 1800 r/min Rated Current = 6.3A(460V)

MTCP2-7P5-3BD18(C)

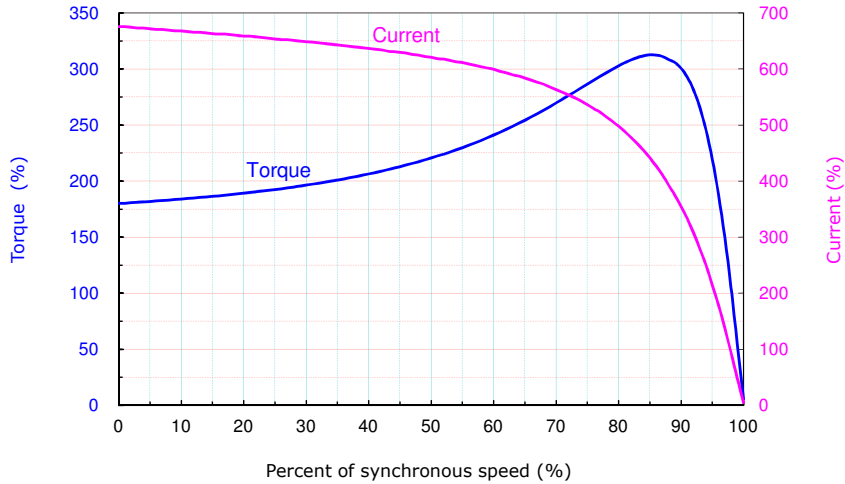

Rated Torque = 22.4 Lb.ft Synchronous Speed = 1800 r/min Rated Current = 9.23 A(460V)

MTCP2-010-3BD18(C)

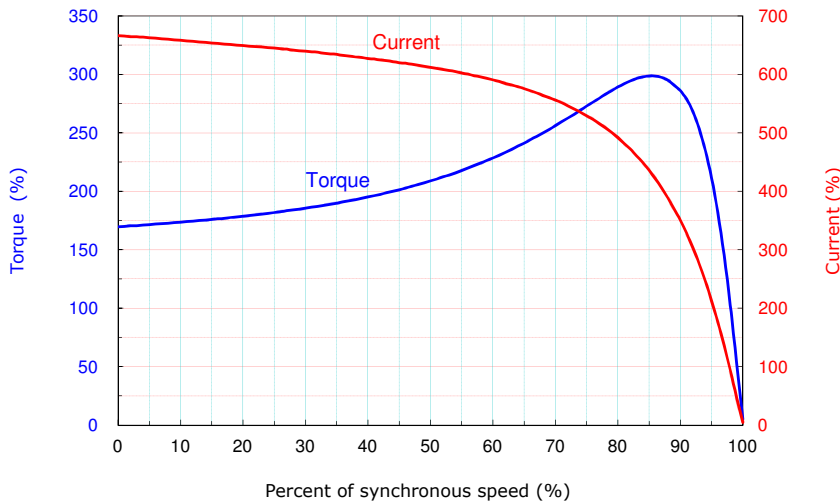

Rated Torque = 29.8 Lb.ft Synchronous Speed = 1800 r/min Rated Current = 12.2A(460V)

MTCP2-020-3BD18(C)

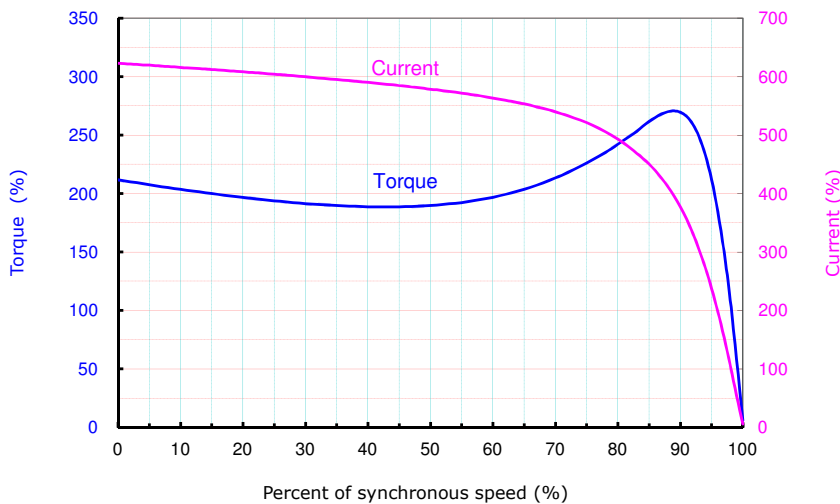

Rated Torque = 59.5 Lb.ft Synchronous Speed = 1800 r/min Rated Current = 23.7A(460V)

MTCP2-025-3BD18(C)

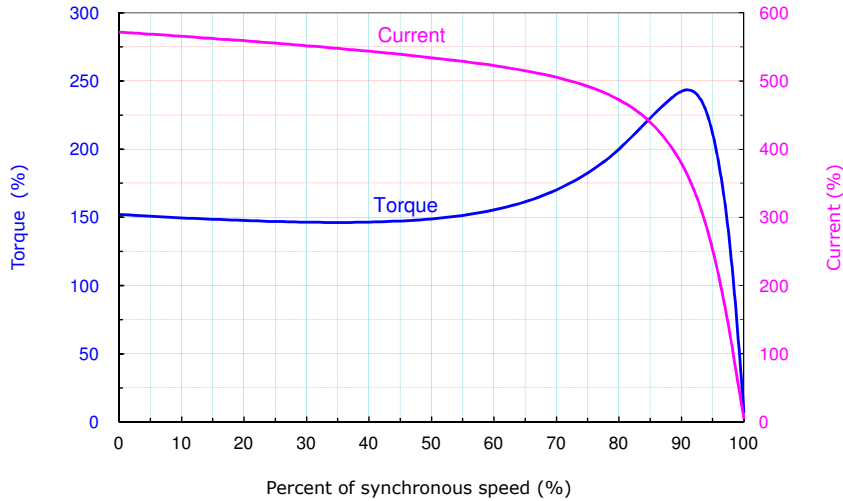

Rated Torque = 74.2 Lb.ft Synchronous Speed = 1800 r/min Rated Current = 29.4 A(460V)

MTCP2-030-3BD18(C)

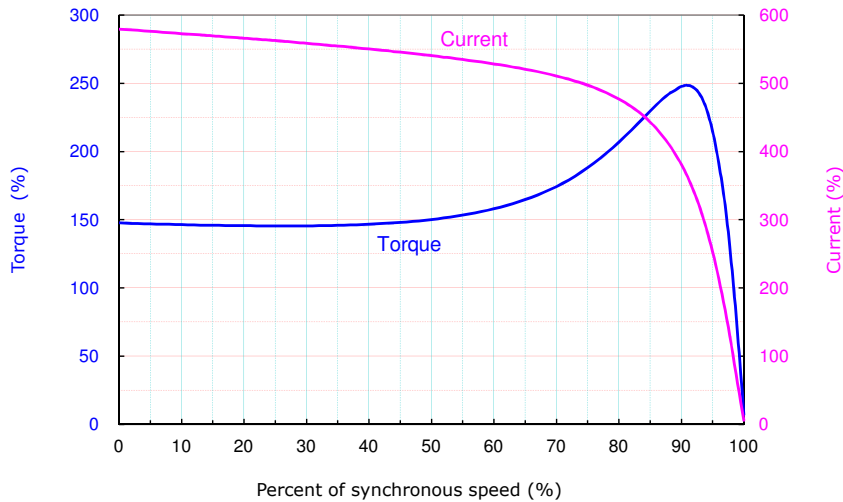

Rated Torque = 89 Lb.ft Synchronous Speed = 1800 r/min Rated Current = 35.3A(460V)

MTCP2-040-3BD18

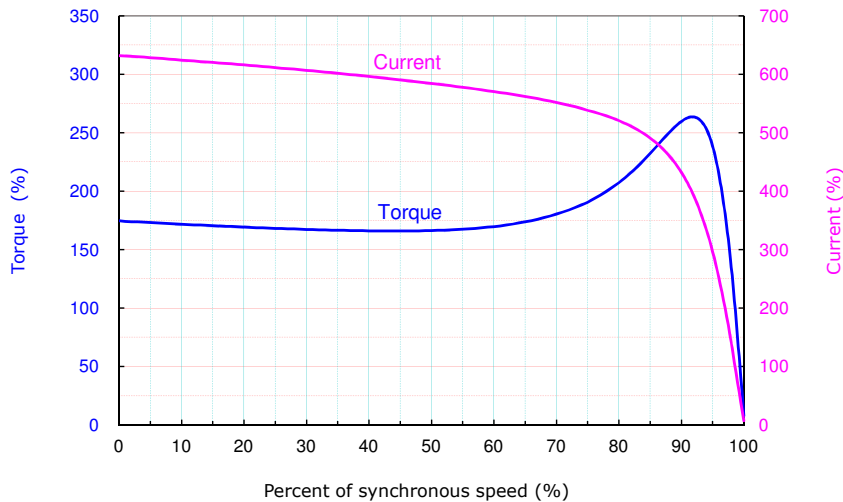

Rated Torque = 118 Lb.ft Synchronous Speed = 1800 r/min Rated Current = 46.3 A(460V)

MTCP2-050-3BD18

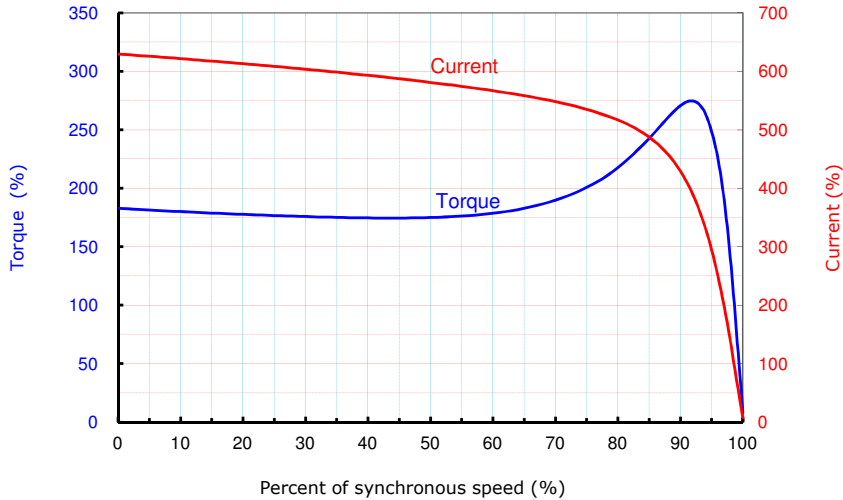

Rated Torque = 148 Lb.ft Synchronous Speed = 1800 r/min Rated Current = 57.6A(460V)

MTCP2-060-3BD18

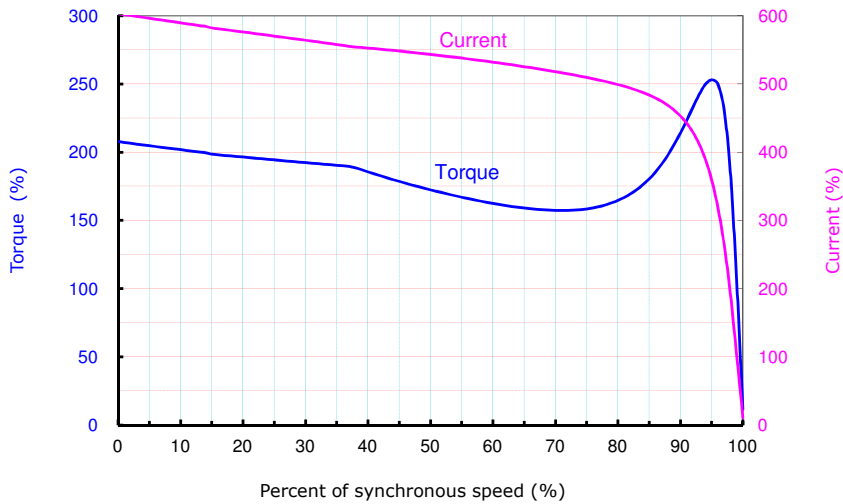

Rated Torque = 177 Lb.ft Synchronous Speed = 1800 r/min Rated Current = 72.1A(460V)

MTCP2-075-3BD18

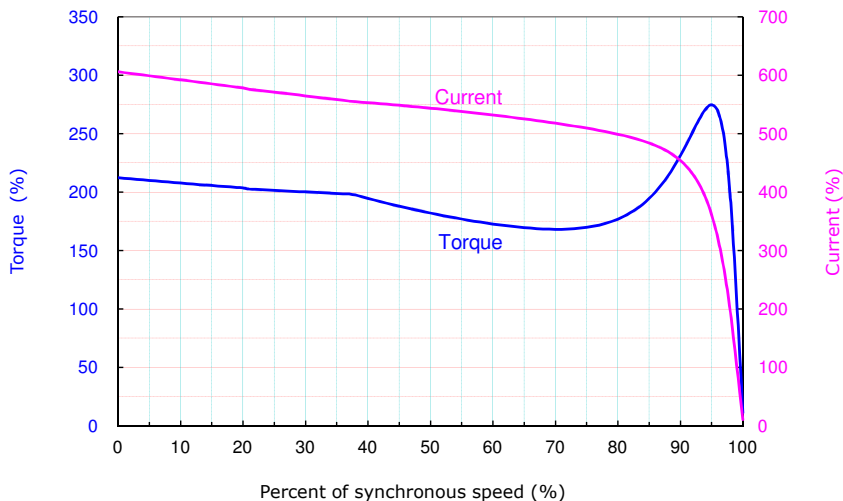

Rated Torque = 221 Lb.ft Synchronous Speed = 1800 r/min Rated Current = 88.7A(460V)

MTCP2-100-3BD18

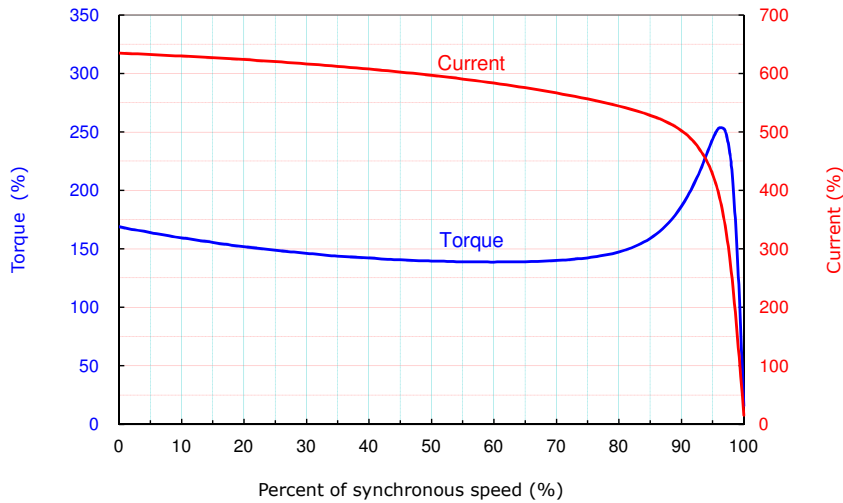

Rated Torque = 294 Lb.ft Synchronous Speed = 1800 r/min Rated Current = 114A(460V)

MTCP2-125-3BD18

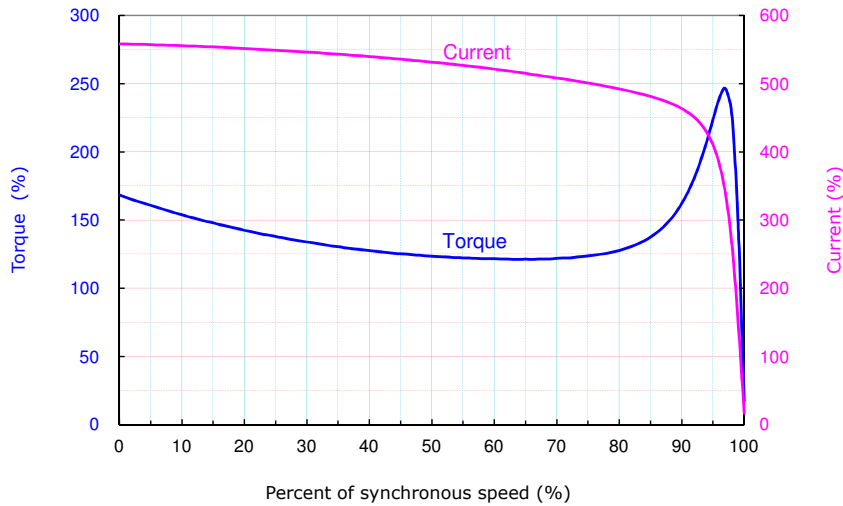

Rated Torque = 367 Lb.ft Synchronous Speed = 1800 r/min Rated Current = 116 A(460V)

MTCP2-150-3BD18

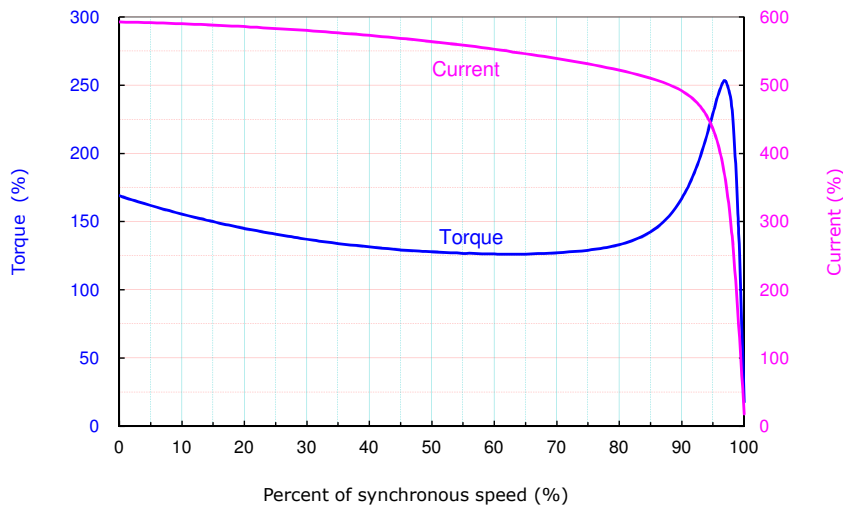

Rated Torque = 440 Lb.ft Synchronous Speed = 1800 r/min Rated Current = 172A(460V)

MTCP2-200-3BD18

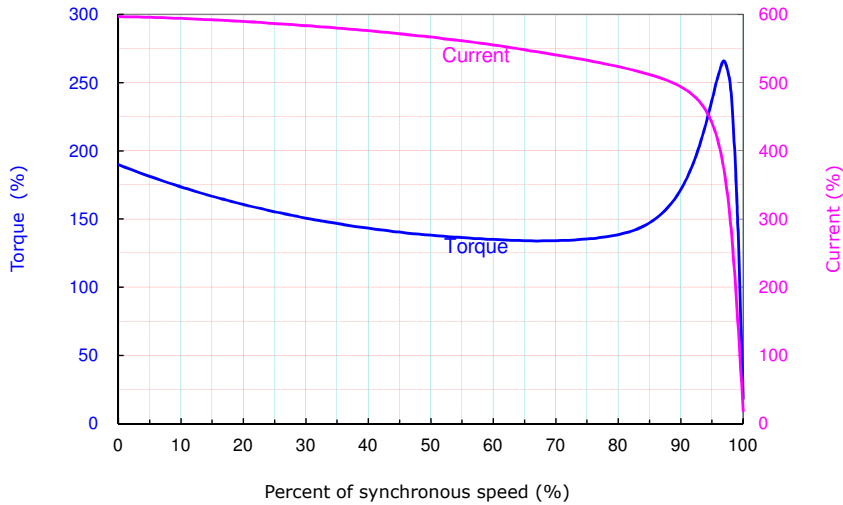

Rated Torque = 587 Lb.ft Synchronous Speed = 1800 r/min Rated Current = 229 A(460V)

MTCP2-250-3D18

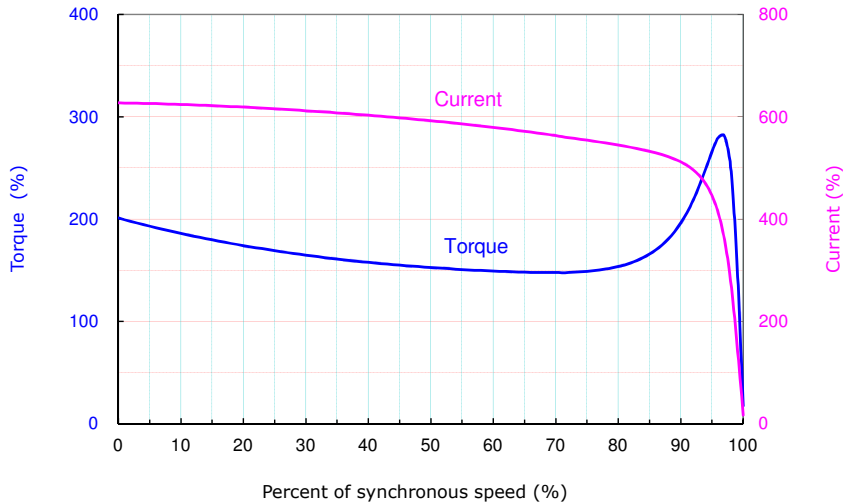

Rated Torque = 773 Lb.ft Synchronous Speed = 1800 r/min Rated Current = 280 A(460V)

MTCP2-300-3D18

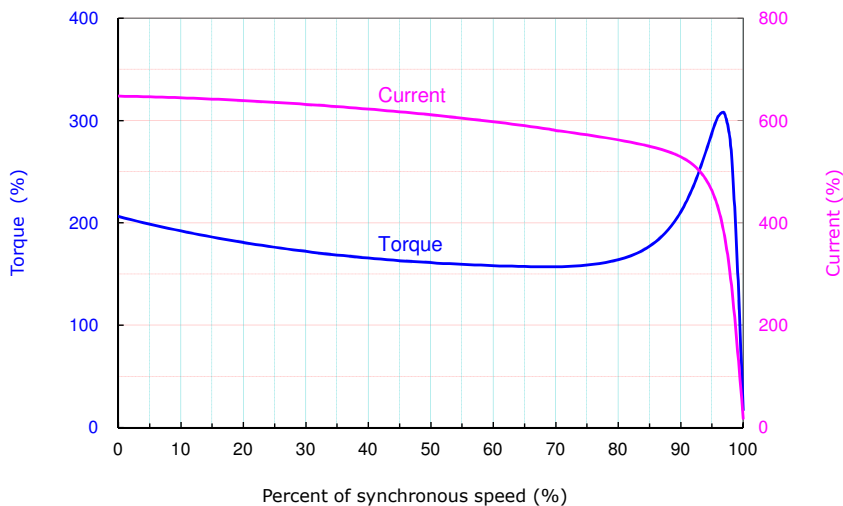

Rated Torque = 880 Lb.ft Synchronous Speed = 1800 r/min Rated Current = 336 A(460V)

SPEED/TORQUE CURVES FOR MTCP2 MOTORS (1200 RPM)

MTCP2-001-3BD12

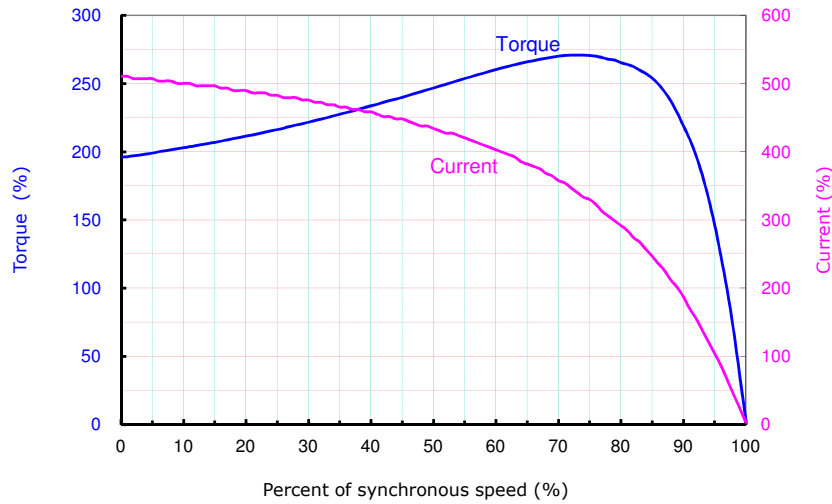

Rated Torque = 4.53 Lb.ft Synchronous Speed = 1200 r/min Rated Current = 1.67A(460V)

MTCP2-1P5-3BD12

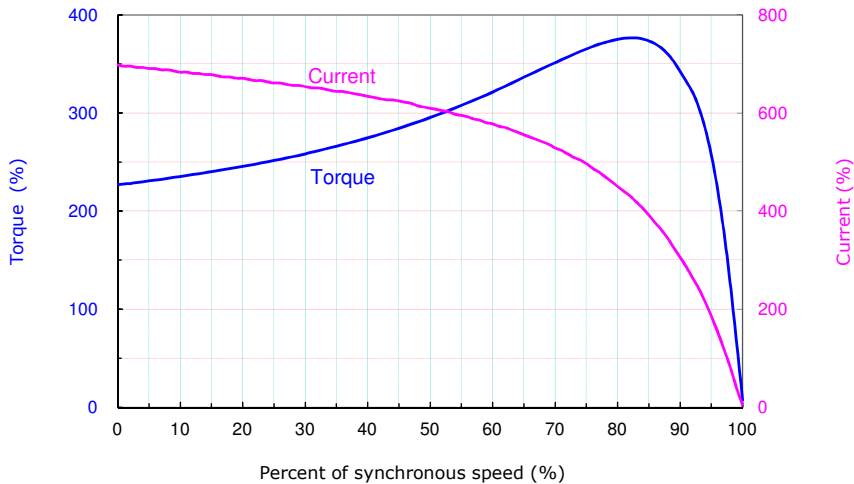

Rated Torque = 6.67 Lb.ft Synchronous Speed = 1200 r/min Rated Current = 2.36A(460V)

MTCP2-002-3BD12

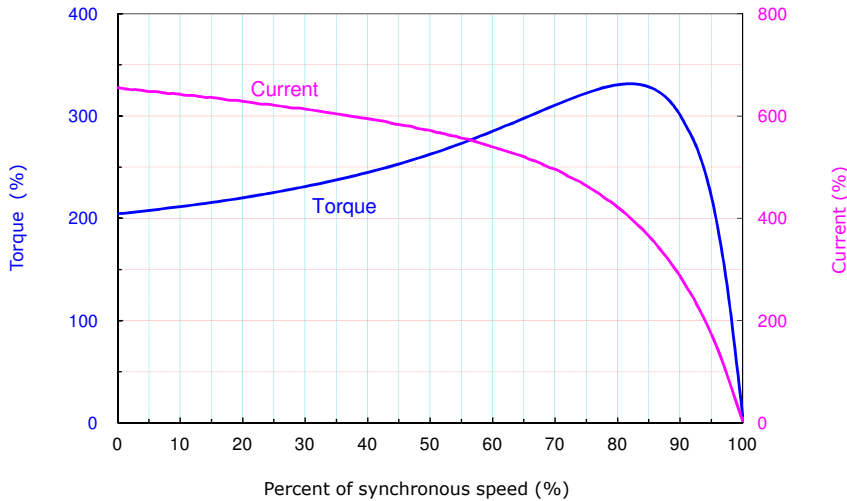

Rated Torque = 8.94 Lb.ft Synchronous Speed = 1200 r/min Rated Current = 2.98A(460V)

MTCP2-003-3BD12

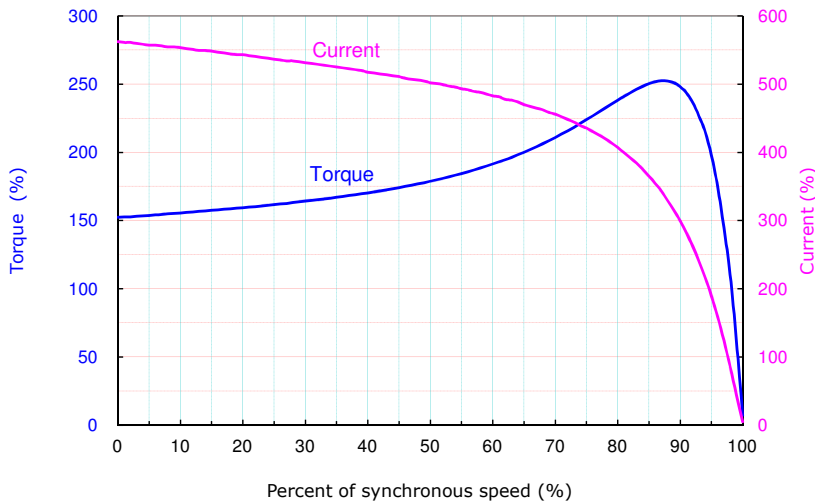

Rated Torque = 13.3 Lb.ft Synchronous Speed = 1200 r/min Rated Current = 4.36 A(460V)

MTCP2-005-3BD12

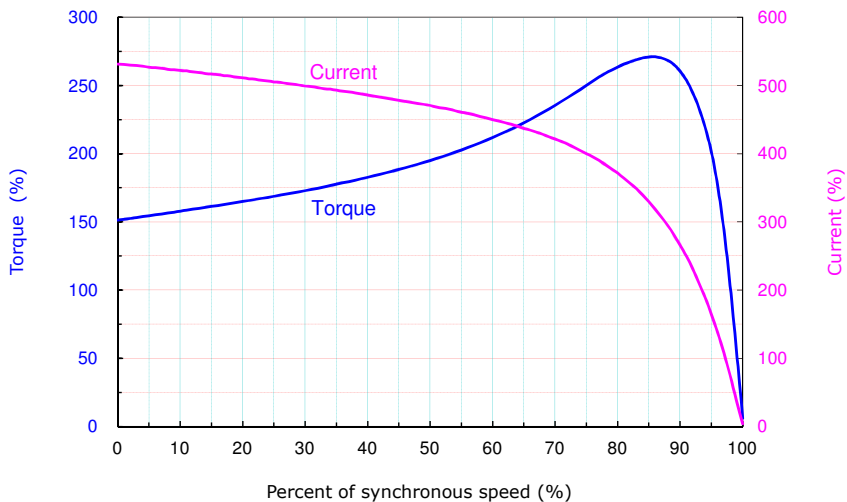

Rated Torque = 22.3 Lb.ft Synchronous Speed = 1200 r/min Rated Current = 7.27 A(460V)

MTCP2-7P5-3BD12

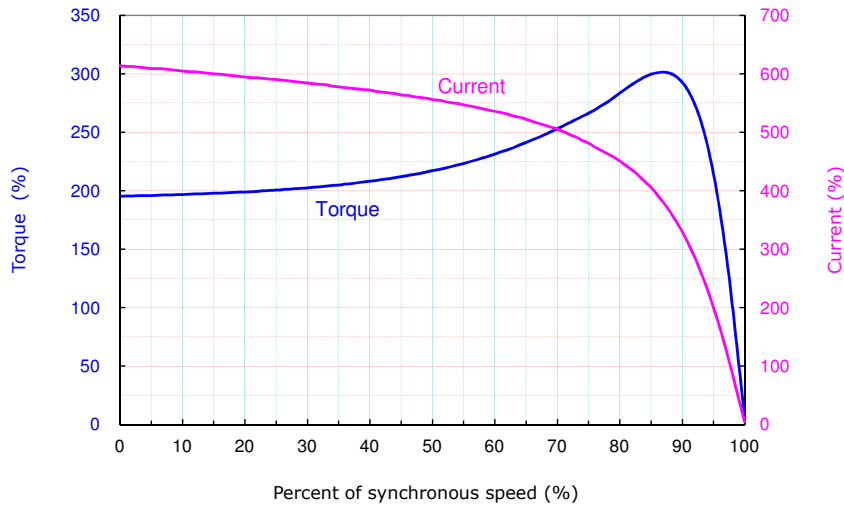

Rated Torque = 33.5 Lb.ft Synchronous Speed = 1200 r/min Rated Current = 9.41 A(460V)

MTCP2-010-3BD12

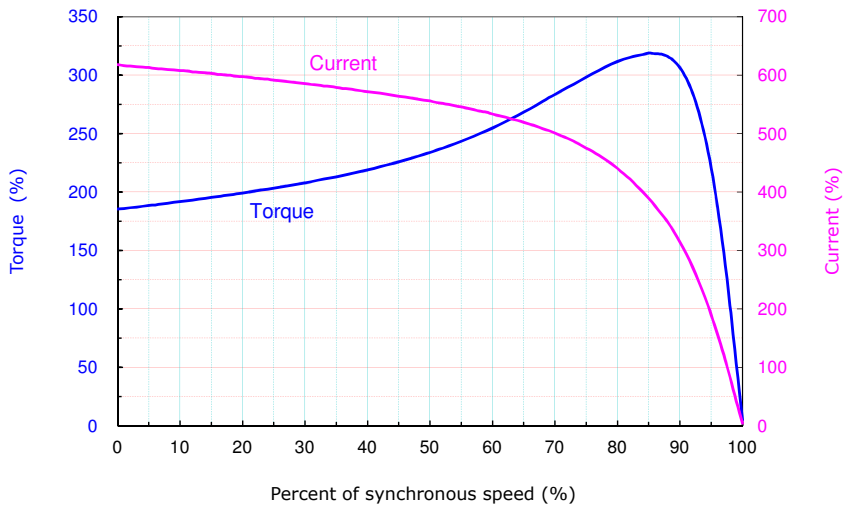

Rated Torque = 44.7 Lb.ft Synchronous Speed = 1200 r/min Rated Current = 12.5 A(460V)

MTCP2-015-3BD12

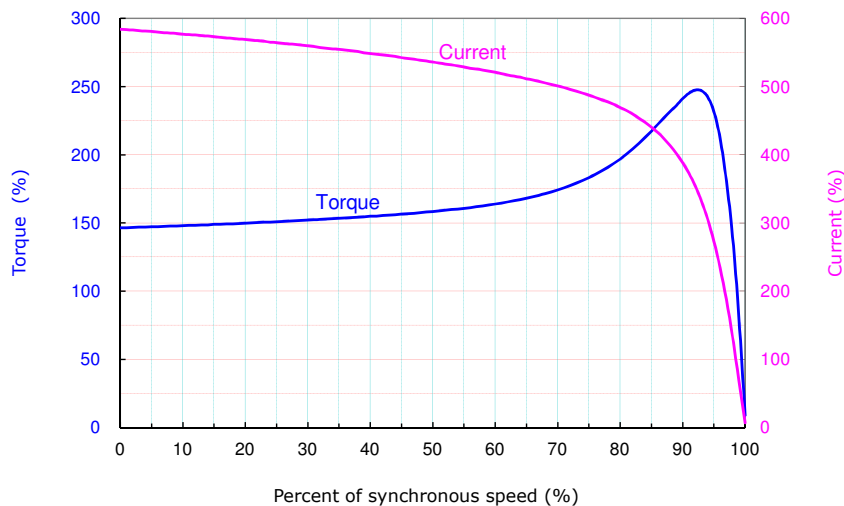

Rated Torque = 66.5 Lb.ft Synchronous Speed = 1200 r/min Rated Current = 18.7 A(460V)

MTCP2-020-3BD12

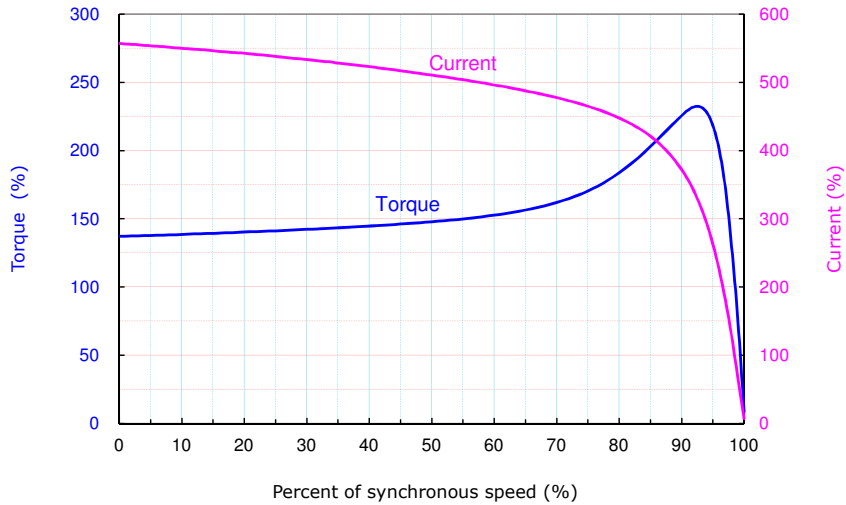

Rated Torque = 88.6 Lb.ft Synchronous Speed = 1200 r/min Rated Current = 24.6 A(460V)

SPEED/TORQUE CURVES FOR MTCP2 MOTORS (3600 RPM)

MTCP2-1P5-3BD36

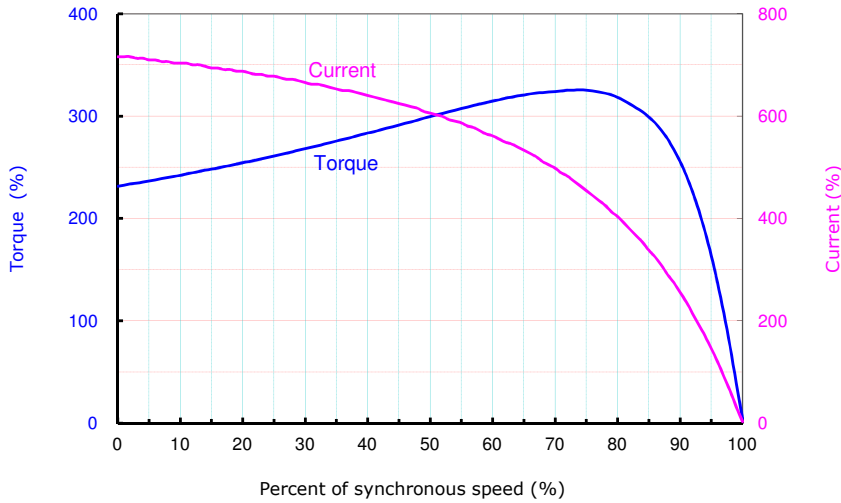

Rated Torque = 2.26 Lb.ft Synchronous Speed = 3600 r/min Rated Current = 2.26A(460V)

MTCP2-002-3BD36

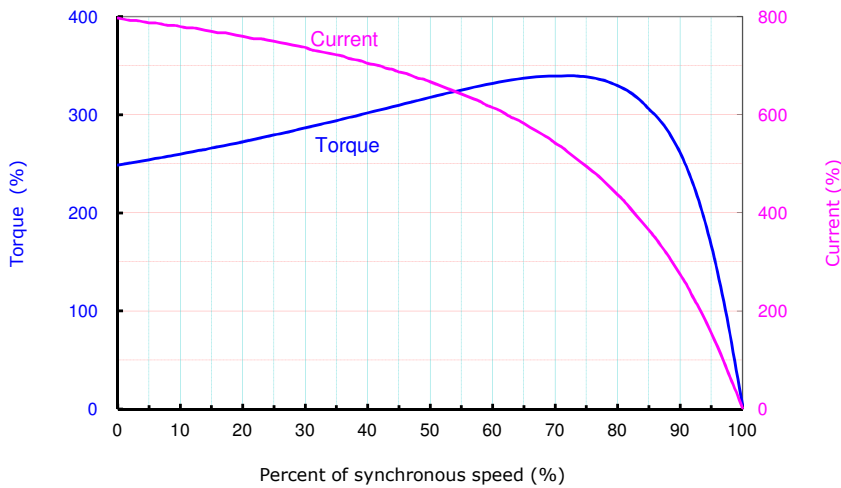

Rated Torque = 3.01 Lb.ft Synchronous Speed = 3600 r/min Rated Current = 2.61A(460V)

MTCP2-003-3BD36

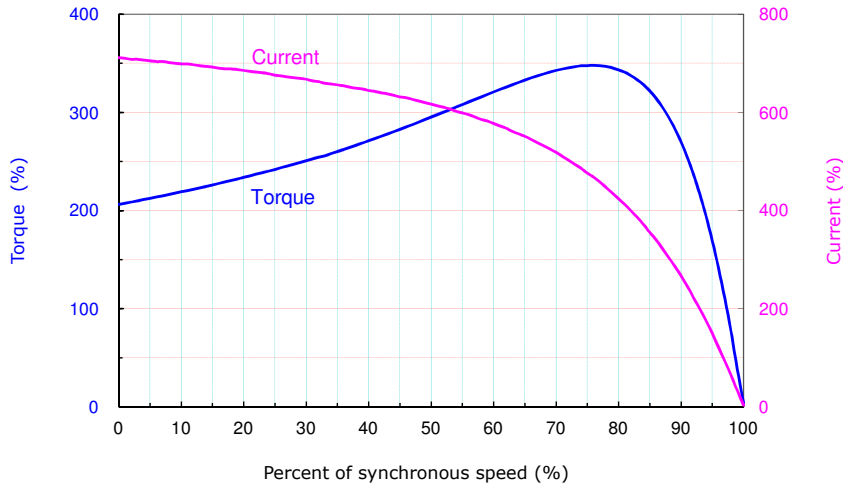

Rated Torque = 4.51 Lb.ft Synchronous Speed = 3600 r/min Rated Current = 3.82A(460V)

MTCP2-005-3BD36

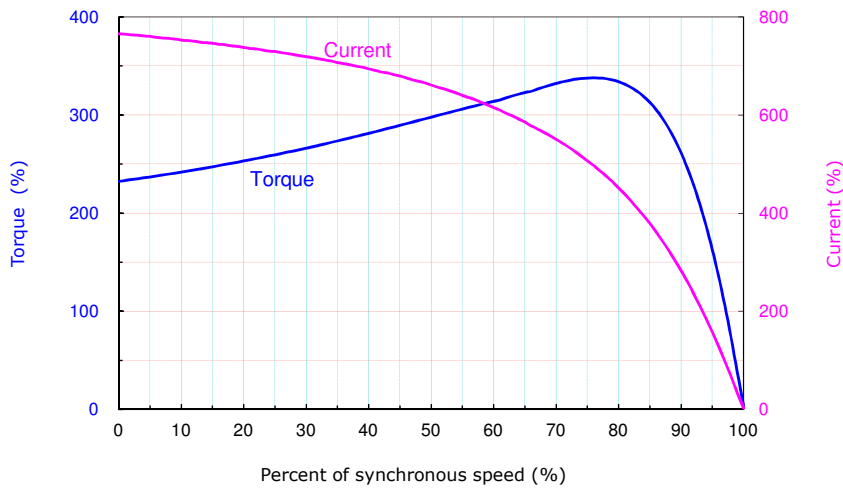

Rated Torque = 7.52 Lb.ft Synchronous Speed = 3600 r/min Rated Current = 6.01A(460V)

MTCP2-7P5-3BD36

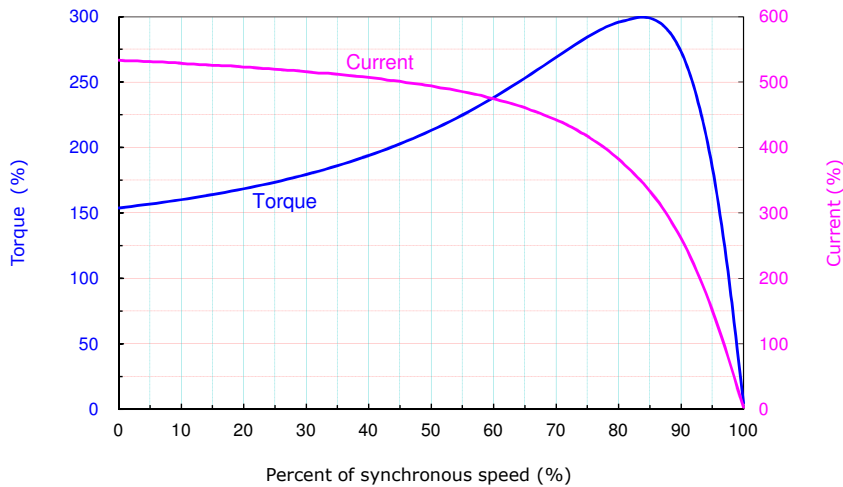

Rated Torque = 11.2 Lb.ft Synchronous Speed = 3600 r/min Rated Current = 9.45 A(460V)

MTCP2-010-3BD36

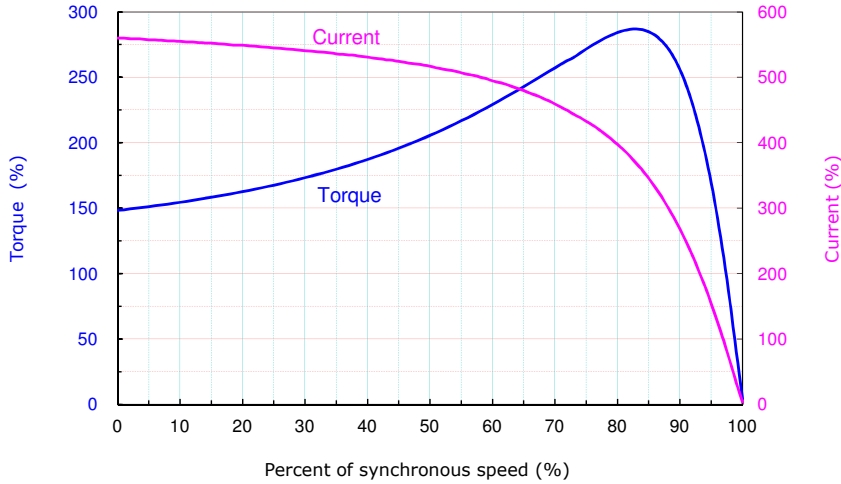

Rated Torque = 15.0 Lb.ft Synchronous Speed = 3600 r/min Rated Current = 12.2 A(460V)

MTCP2-015-3BD36

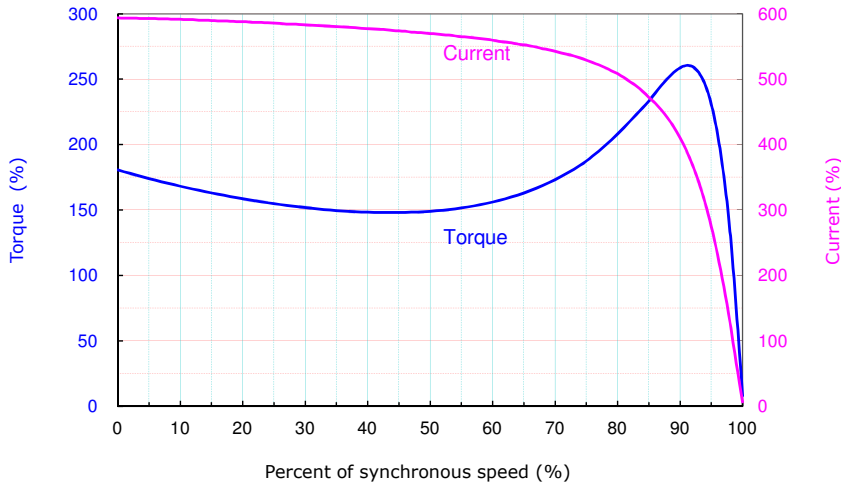

Rated Torque = 22.2 Lb.ft Synchronous Speed = 3600 r/min Rated Current = 17.3 A(460V)

MTCP2-020-3BD36

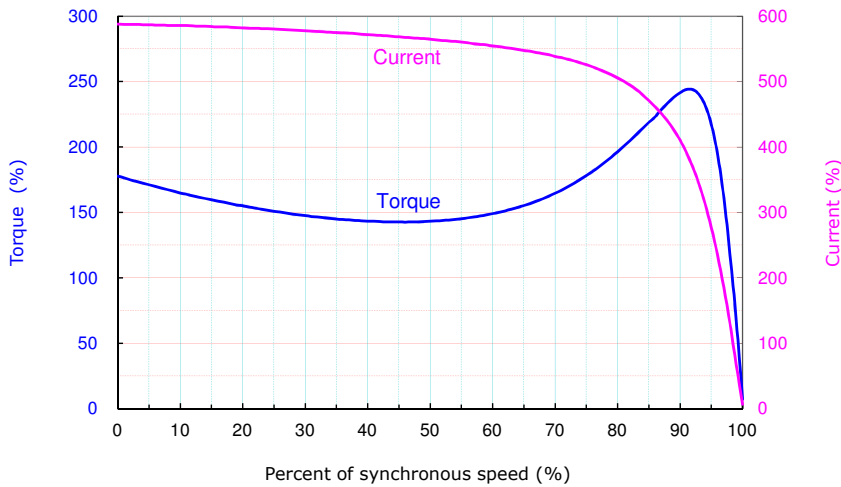

Rated Torque = 29.7 Lb.ft Synchronous Speed = 3600 r/min Rated Current = 22.9 A(460V)

BLANK
PAGE

LEGACY MOTORS

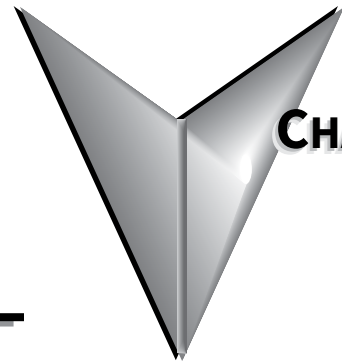

CHAPTER

6

TABLE OF CONTENTS

Chapter Overview	6-3
MTCP Series Motors.	6-3
MTCP Features and Specifications	6-3
MTCP Specifications.	6-4
MTCP Motor Performance Data	6-6
MTCP Motor Dimensions	6-10
MTCP Junction Box Dimensions	6-16
MTCP Decibel Levels.	6-17
Spare/Replacement Parts for MTCP Premium-Efficiency Three-Phase Motors	6-18
MTCP Bearing Size Information	6-20
MTR Series Motors	6-21
MTR Features and Specifications (Single-Phase Motors).	6-21
MTR Features and Specifications (Three-Phase Motors)	6-22
MTR Motor Dimensions.	6-24
MTR Junction Box Dimensions	6-25
MTR Terminal and Wiring Diagrams	6-25
MTR Motors Decibel Levels.	6-25
Spare/Replacement Parts for MTR Single-Phase Motors.	6-26
MTR Bearing Size Information	6-26
MTSS Series Motors.	6-27
MTSS Features and Specifications	6-27
MTSS Motor Dimensions	6-29
MTSS Junction Box Dimensions	6-30
MTSS Decibel Levels.	6-30
MTSS Motor Mounting	6-31
Spare/Replacement Parts for MTSS Stainless-Steel Three-Phase Motors.	6-32
MTSS Bearing Size Information.	6-32
MTC EAct Series Motors	6-33
MTC Features and Specifications.	6-33
MTC Motor Dimensions.	6-41
MTC Junction Box Dimensions	6-46
MTC Motors Decibel Levels.	6-47
C-Flange Kits for MTC EAct Three-Phase Motors	6-47
MTC Motors Bearing Size Information.	6-49
MTF Farm-Duty T-Frame Single-Phase Motors – Features and Specifications	6-50

(CONTINUED ON NEXT PAGE)

LEGACY MOTORS



CHAPTER

6

<i>Motor Dimensions</i>	6-51
<i>MTF T-Frame Single-phase Farm-Duty Motor Dimensions</i>	6-51
<i>Terminal and Wiring Diagrams</i>	6-51
<i>Replacement Parts</i>	6-52
<i>Capacitors and Centrifugal Switches for IronHorse® Single-Phase Motors</i>	6-52
<i>Spare/Replacement Parts for MTF Single-Phase Farm-Duty Motors</i>	6-52
<i>Junction Box Dimensions</i>	6-53

CHAPTER OVERVIEW

This chapter provides technical information for Ironhorse AC motors that have been retired by ADC. *These legacy models are no longer sold by AutomationDirect*, but are detailed in this chapter to keep motor data available during the motors' lifetime.

We also encourage you to visit our web site where you can find technical and non-technical information about our products and our company. Visit us at www.automationdirect.com.

MTCP SERIES MOTORS

MTCP FEATURES AND SPECIFICATIONS

Premium Efficiency Cast-Iron T-Frame



Premium Efficiency Cast-Iron TC-Frame



IronHorse cast-iron industrial-duty Premium Efficiency motors are available in T-frame housings in speeds of 1200, 1800, and 3600 rpm, and in TC-frame housings in speeds of 1800 rpm. Optional C-face kits are available for IronHorse T-frame Premium Efficiency motors. (Premium Efficiency C-face kits are NOT compatible with EPAct motors.) All models have a TEFC frame and full length mounting feet.



NOTE: For MTCP motors shipped with a shaft lock in place, remove the shaft lock after the motor is installed and before coupling and turning the shaft.

MTCP SPECIFICATIONS

MTCP SPECIFICATIONS – CAST-IRON T-FRAME AND TC-FRAME – 60Hz/1800RPM (50Hz/1500RPM)

Motor Specifications Premium-Efficiency T & TC Frame Three-Phase Motors 60Hz/1800rpm (50Hz/1500rpm)										
Part Number	HP(2)	NEMA Frame	Voltage @ 60Hz (50Hz)	Housing	Shaft Material	Conduit Box Location (1)	Holes / Foot	Service Factor	F.L. Amps @ 230V/460V (200V/400V)	Product Weight (lb)
MTCP-001-3BD18	1	143T	208-230/460 – 3-phase (200/400 – 3-phase)	TEFC cast iron	1045 carbon steel	F1(F2)	1.15 (1.0)		3.22 / 1.61 (3.70 / 1.85)	41
MTCP-001-3BD18C		143TC							45	
MTCP-1P5-3BD18	1-1/2	145T							4.64 / 2.32 (5.34 / 2.67)	47
MTCP-1P5-3BD18C		145TC							50	
MTCP-002-3BD18	2	145T							6.00 / 3.00 (6.90 / 3.50)	56
MTCP-002-3BD18C		145TC							60	
MTCP-003-3BD18	3	182T							8.05 / 4.02 (9.26 / 4.63)	84
MTCP-003-3BD18C		182TC							92	
MTCP-005-3BD18	5	184T							13.4 / 6.71 (15.4 / 7.71)	99
MTCP-005-3BD18C		184TC							107	
MTCP-7P5-3BD18	7-1/2	213T							18.7 / 9.34 (21.5 / 10.7)	150
MTCP-7P5-3BD18C		213TC							154	
MTCP-010-3BD18	10	215T							24.9 / 12.5 (28.6 / 14.3)	186
MTCP-010-3BD18C		215TC							190	
MTCP-015-3BD18	15	254T							35.8 / 17.9 (41.2 / 20.6)	329
MTCP-015-3BD18C		254TC							325	
MTCP-020-3BD18	20	256T							47.9 / 24.0 (55.1 / 27.6)	390
MTCP-020-3BD18C		256TC							370	
MTCP-025-3BD18	25	284T							59.6 / 29.8 (68.5 / 34.3)	455
MTCP-025-3BD18C		284TC							467	
MTCP-030-3BD18	30	286T							70.0 / 35.0 (80.5 / 40.2)	488
MTCP-030-3BD18C		286TC							497	
MTCP-040-3BD18	40	324T							94.8 / 47.4 (109 / 54.5)	611
MTCP-040-3BD18C		324TC							626	
MTCP-050-3BD18 (2)	50	326T							117 / 58.4 (134 / 67.2)	690
MTCP-050-3BD18C (2)		326TC							706	
MTCP-060-3BD18 (2)	60	364T							139 / 69.6 (160 / 80.1)	851
MTCP-060-3BD18C (2)		364TC							864	
MTCP-075-3BD18 (2)	75	365T	173 / 86.7 (199 / 99.7)	948						
MTCP-075-3BD18C (2)		365TC	961							
MTCP-100-3BD18 (2)	100	405T	229 / 114 (263 / 132)	1199						
MTCP-100-3BD18C (2)		405TC	1236							
MTCP-125-3BD18 (2)	125	444T	285 / 143 (328 / 164)	1500						
MTCP-150-3BD18 (2)	150	445T	342 / 171 (414 / 207)	1630						
MTCP-200-3BD18 (2)	200	445/7T	453 / 227 (521 / 261)	2127						

1) F1(F2) indicates F1 conduit box mounting location, field convertible to F2 (as shown on dimensional diagram).

2) For warranty on motors 50 hp and above, motors must be inspected by an EASA motor repair or service center. See AutomationDirect Terms & Conditions for details.

**MTCP SPECIFICATIONS – CAST-IRON T-FRAME AND TC-FRAME
– 60Hz/1200&3600RPM (50Hz/1000&3000 RPM)**

Motor Specifications Premium Efficiency T-Frame Three-Phase Motors 60Hz / 1200 & 3600 rpm (50Hz / 1000 & 3000 rpm)										
Part Number	HP	NEMA Frame	Voltage @ 60Hz (50Hz)	Housing	Shaft Material	Conduit Box Location (1)	Holes / Foot	Service Factor	F.L. Amps @ 230V/460V (200V/400V)	Product Weight (lb)
1200 rpm Base Speed @ 60Hz (1000 rpm Base Speed @ 50Hz)										
MTCP-001-3BD12	1	145T	208-230/460 – 3-phase (200/400 – 3-phase)	TEFC cast iron	1045 carbon steel	F1(F2)	4	1.15 (1.0)	3.16 / 1.58 (3.63 / 1.82)	60
MTCP-1P5-3BD12	1-1/2	182T					2		4.46 / 2.23 (5.13 / 2.57)	104
MTCP-002-3BD12	2	184T					4		5.72 / 2.86 (6.58 / 3.29)	110
MTCP-003-3BD12	3	213T					2		8.48 / 4.24 (9.75 / 4.88)	160
MTCP-005-3BD12	5	215T					4		13.8 / 6.88 (15.8 / 7.91)	180
MTCP-7P5-3BD12	7-1/2	254T					2		20.9 / 10.4 (24.0 / 12.0)	325
MTCP-010-3BD12	10	256T					4		27.8 / 13.9 (32.0 / 16.0)	325
MTCP-015-3BD12	15	284T					2		40.3 / 20.2 (46.4 / 23.2)	420
MTCP-020-3BD12	20	286T					4		52.4 / 26.2 (60.2 / 30.1)	470
3600 rpm Base Speed (3000 rpm Base Speed @ 50Hz)										
MTCP-1P5-3BD36	1-1/2	143T	208-230/460 – 3-phase (200/400 – 3-phase)	TEFC cast iron	1045 carbon steel	F1(F2)	2	1.15 (1.0)	4.08 / 2.04 (4.69 / 2.35)	44
MTCP-002-3BD36	2	145T					4		5.40 / 2.70 (6.20 / 3.10)	53
MTCP-003-3BD36	3	182T					2		7.74 / 3.87 (8.90 / 4.45)	79
MTCP-005-3BD36	5	184T					4		12.6 / 6.30 (14.5 / 7.25)	92
MTCP-7P5-3BD36	7-1/2	213T					2		18.5 / 9.23 (21.2 / 10.6)	140
MTCP-010-3BD36	10	215T					4		24.4 / 12.2 (28.1 / 14.1)	161
MTCP-015-3BD36	15	254T					2		35.0 / 17.5 (40.3 / 20.1)	278
MTCP-020-3BD36	20	256T					4		46.4 / 23.2 (53.4 / 26.7)	306
1) F1(F2) indicates F1 conduit box mounting location, field convertible to F2 (as shown on dimensional diagram).										

MTCP MOTOR PERFORMANCE DATA

MTCP PERFORMANCE DATA – CAST-IRON T-FRAME AND TC-FRAME – 60Hz/1800RPM

Performance Data @ 60Hz Premium-Efficiency T & TC Frame Three-Phase Motors – 1800 rpm (460 Volt except as indicated)											
Part Number	HP	NEMA Design	F.L. RPM	Speed (rpm)				F.L. Efficiency (%)	F.L. Power Factor	Rotor Inertia (lb·ft ²)	Slip (%)
				Minimum		Maximum					
				Constant Torque (4:1)	Variable Torque (10:1)	CHP(1)	Safe				
MTCP-001-3BD18(C)	1	B	1750	450	180	2700	5400	86.3	0.690	0.089	1.81
MTCP-1P5-3BD18(C)	1-1/2		1750					87.3	0.726	0.11	2.80
MTCP-002-3BD18(C)	2		1750					87.3	0.725	0.13	2.80
MTCP-003-3BD18(C)	3		1750					90.3	0.786	0.28	1.60
MTCP-005-3BD18(C)	5		1750					90.3	0.786	0.33	2.00
MTCP-7P5-3BD18(C)	7-1/2		1760					91.8	0.825	1.814	1.54
MTCP-010-3BD18(C)	10		1750					92.5	0.826	1.97	1.31
MTCP-015-3BD18(C)	15		1750					92.5	0.890	3.33	1.22
MTCP-020-3BD18(C)	20		1770					93.8	0.846	4.09	1.70
MTCP-025-3BD18(C)	25		1770					93.6	0.860	7.01	1.67
MTCP-030-3BD18(C)	30		1780				93.7	0.846	8.3	1.10	
MTCP-040-3BD18(C)	40		1780				94.4	0.850	9	1.11	
MTCP-050-3BD18(C)	50		1775				94.5	0.855	14.1	0.78	
MTCP-060-3BD18(C)	60		1788				95.0	0.850	16.27	0.66	
MTCP-075-3BD18(C)	75		1787				95.4	0.850	18.8	0.69	
MTCP-100-3BD18(C)	100		1790				95.4	0.860	45.5	0.56	
MTCP-125-3BD18	125		1790				95.4	0.860	65.1	0.56	
MTCP-150-3BD18	150		1790				95.8	0.860	69.26	0.53	
MTCP-200-3BD18	200		1790				96.3	0.860	84.0	0.52	

1) Maximum Constant HP RPM is for direct-coupled loads.

Part Number (repeated)	HP	Current @ 230V/460V (Amps)			Torque (lb·ft)			Max Time @ Locked Rotor Current (hot)	Temperature Rise @ Full Load
		No Load	Full Load	Locked Rotor	Full Load	Locked Rotor	Break-down		
MTCP-001-3BD18(C)	1	2.3 / 1.1	3.2 / 1.6	30.0 / 15.0	3.0	9.0	11.4	20 seconds	80°C [176°F]
MTCP-1P5-3BD18(C)	1-1/2	3.1 / 1.6	4.6 / 2.3	40.0 / 20.0	4.5	9.0	14.0		
MTCP-002-3BD18(C)	2	3.6 / 1.8	6.0 / 3.0	50.0 / 25.0	6.0	17.4	19.2		
MTCP-003-3BD18(C)	3	4.1 / 2.1	8.1 / 4.0	64.0 / 32.0	9.0	20.7	25.2		
MTCP-005-3BD18(C)	5	6.2 / 3.1	13.4 / 6.7	92.0 / 46.0	15.0	34.5	43.5		
MTCP-7P5-3BD18(C)	7-1/2	8.4 / 4.2	18.7 / 9.3	127 / 63.5	22.4	44.8	69.4		
MTCP-010-3BD18(C)	10	10.5 / 5.3	24.9 / 12.5	163 / 81.5	30.0	61.5	93.0		
MTCP-015-3BD18(C)	15	15.4 / 7.7	35.8 / 17.9	232 / 116	45	92	126		
MTCP-020-3BD18(C)	20	17.1 / 8.6	47.9 / 24.0	290 / 145	59.4	118.8	166.3		
MTCP-025-3BD18(C)	25	24 / 12	59.6 / 29.8	365 / 182.5	74.2	155.8	185.5		
MTCP-030-3BD18(C)	30	27 / 13.5	70.0 / 35.0	435 / 217.5	88.6	203.8	248.1		
MTCP-040-3BD18(C)	40	29.6 / 14.8	94.8 / 47.4	580 / 290	118.1	248.0	271.6		
MTCP-050-3BD18(C)	50	36.2 / 18.1	116.8 / 58.4	725 / 362.5	148	326	414		
MTCP-060-3BD18(C)	60	45.6 / 22.8	139.3 / 69.6	870 / 435	179	376	519		
MTCP-075-3BD18(C)	75	58.4 / 29.2	173.4 / 86.7	1085 / 542.5	221	464	619		
MTCP-100-3BD18(C)	100	75 / 37.5	228.6 / 114.3	1450 / 725	293.2	645.0	703.7	20 seconds	
MTCP-125-3BD18	125	94.5 / 47.3	285.2 / 142.6	1816 / 908	367	624	918		
MTCP-150-3BD18	150	104.4 / 52.2	342 / 171	2170 / 1085	443	797	1108	18 seconds	
MTCP-200-3BD18	200	133.3 / 66.6	453.2 / 226.6	2900 / 1450	587	1174	1644		

MTCP MOTOR PERFORMANCE DATA – CAST-IRON T-FRAME – 60HZ/1200RPM

Performance Data @ 60Hz – Premium Efficiency T-Frame 3-Phase Motors – 1200 rpm – (460 Volt except as indicated)											
Part Number	HP	NEMA Design	F.L. RPM	Speed (rpm)				F.L. Efficiency (%)	F.L. Power Factor	Rotor Inertia (lb-ft ²)	Slip (%)
				Minimum		Maximum					
				Constant Torque (4:1)	Variable Torque (10:1)	CHP(1)	Safe				
MTCP-001-3BD12	1	B	1162	300	120	1800	3600	82.5	0.72	0.33	3.14
MTCP-1P5-3BD12	1-1/2		87.5					0.72	0.36	1.85	
MTCP-002-3BD12	2		88.5					0.74	0.47	2.0	
MTCP-003-3BD12	3		89.5					0.74	0.50	1.65	
MTCP-005-3BD12	5		89.5					0.76	1.97	1.85	
MTCP-7P5-3BD12	7-1/2		91.1					0.74	2.74	1.51	
MTCP-010-3BD12	10		91.0					0.74	2.98	1.56	
MTCP-015-3BD12	15		91.7					0.76	5.49	1.16	
MTCP-020-3BD12	20		91.7					0.78	12.9	1.21	

1) Maximum Constant HP RPM is for direct-coupled loads.

Part Number (repeated)	HP	Current @ 230V/460V (Amps)			Torque (lb-ft)			Max Time @ Locked Rotor Current (hot)	Temperature Rise @ Full Load
		No Load	Full Load	Locked Rotor	Full Load	Locked Rotor	Break-down		
MTCP-001-3BD12	1	2.5 / 1.25	3.2 / 1.6	30 / 15	4.5	10.8	14.4	20 seconds	80°C [176°F]
MTCP-1P5-3BD12	1-1/2	3.2 / 1.6	4.5 / 2.2	40 / 20	6.68	15.36	21.38		
MTCP-002-3BD12	2	4.2 / 2.1	5.7 / 2.9	50.0 / 25.0	8.61	20.66	29.88		
MTCP-003-3BD12	3	6.4 / 3.2	8.5 / 4.2	68.0 / 34.0	13.36	29.39	40.08		
MTCP-005-3BD12	5	9.2 / 4.6	13.8 / 6.9	92.0 / 46.0	22.2	48.8	66.6		
MTCP-7P5-3BD12	7-1/2	12.0 / 6.0	20.9 / 10.4	127 / 63.5	33.4	76.8	116.9		
MTCP-010-3BD12	10	10.8 / 5.4	27.8 / 13.9	162 / 81	44.5	97.9	106.8		
MTCP-015-3BD12	15	18.0 / 9.0	40.3 / 20.2	232 / 116	60.23	132.51	174.67		
MTCP-020-3BD12	20	17.8 / 8.9	52.4 / 26.2	290 / 145	89.1	196.0	258.4		

MTCP MOTOR PERFORMANCE DATA – CAST-IRON T-FRAME – 60HZ/3600RPM

Performance Data @ 60Hz – Premium Efficiency T-Frame 3-Phase Motors – 3600 rpm – (460 Volt except as indicated)											
Part Number	HP	NEMA Design	F.L. RPM	Speed (rpm)				F.L. Efficiency (%)	F.L. Power Factor	Rotor Inertia (lb-ft ²)	Slip (%)
				Minimum		Maximum					
				Constant Torque (4:1)	Variable Torque (10:1)	CHP(1)	Safe				
MTCP-1P5-3BD36	1-1/2	B	3570	900	360	5400	5400	85.5	0.83	0.08	2.00
MTCP-002-3BD36	2		3520					86.6	0.82	0.10	2.20
MTCP-003-3BD36	3		3520					87.0	0.85	0.20	1.60
MTCP-005-3BD36	5		3570					89.0	0.84	0.22	1.46
MTCP-7P5-3BD36	7-1/2		3520					89.7	0.85	0.50	1.67
MTCP-010-3BD36	10		3550					90.3	0.85	1.2	1.40
MTCP-015-3BD36	15		3550					91.2	0.85	1.86	1.11
MTCP-020-3BD36	20		3570					91.2	0.85	2.01	0.97

1) Maximum Constant HP RPM is for direct-coupled loads.

Part Number (repeated)	HP	Current @ 230V/460V (Amps)			Torque (lb-ft)			Max Time @ Locked Rotor Current (hot)	Temperature Rise @ Full Load
		No Load	Full Load	Locked Rotor	Full Load	Locked Rotor	Break-down		
MTCP-1P5-3BD36	1-1/2	2.0 / 1.0	4.1 / 2.0	40.0 / 20.0	2.2	6.4	7.9	20 seconds	80°C [176°F]
MTCP-002-3BD36	2	3.1 / 1.6	5.4 / 2.7	50.0 / 25.0	3.0	9.0	12.0		
MTCP-003-3BD36	3	3.9 / 2.0	7.7 / 3.9	64.0 / 32.0	4.48	12.54	17.02		
MTCP-005-3BD36	5	5.2 / 2.6	12.6 / 6.3	92.0 / 46.0	7.36	16.19	22.82		
MTCP-7P5-3BD36	7-1/2	6.7 / 3.3	18.5 / 9.2	127 / 63.5	11.2	28.0	34.7		
MTCP-010-3BD36	10	8.8 / 4.4	24.4 / 12.2	163 / 81.5	14.8	37.0	50.3		
MTCP-015-3BD36	15	12 / 6	35.0 / 17.5	232 / 116	22.2	46.6	64.4		
MTCP-020-3BD36	20	15 / 7.5	46.4 / 23.2	290 / 145	29.4	61.7	85.3		

MTCP MOTOR PERFORMANCE DATA – CAST-IRON T-FRAME AND TC-FRAME – 50Hz/1500RPM

Performance Data @ 50Hz Premium-Efficiency T & TC Frame Three-Phase Motors – 1500 rpm (400 Volt except as indicated)											
Part Number	HP	NEMA Design	F.L. RPM	Speed (rpm)				F.L. Efficiency (%)	F.L. Power Factor	Rotor Inertia (lb-ft ²)	Slip (%)
				Minimum		Maximum					
				Constant Torque	Variable Torque	CHP(1)	Safe				
MTCP-001-3BD18(C)	1	B	1453	450	180	2700	5400	86.3	0.690	0.089	1.81
MTCP-1P5-3BD18(C)	1.5		1453					87.3	0.726	0.11	2.80
MTCP-002-3BD18(C)	2		1453					87.3	0.725	0.13	2.80
MTCP-003-3BD18(C)	3		1453					90.3	0.786	0.28	1.60
MTCP-005-3BD18(C)	5		1453					90.3	0.786	0.33	2.00
MTCP-7P5-3BD18(C)	7-1/2		1461					91.8	0.825	1.814	1.54
MTCP-010-3BD18(C)	10		1453					92.5	0.826	1.97	1.31
MTCP-015-3BD18(C)	15		1453					92.5	0.890	3.33	1.22
MTCP-020-3BD18(C)	20		1469					93.8	0.846	4.09	1.70
MTCP-025-3BD18(C)	25		1469					93.6	0.860	7.01	1.67
MTCP-030-3BD18(C)	30		1477				93.7	0.846	8.3	1.10	
MTCP-040-3BD18(C)	40		1477				94.4	0.850	9	1.11	
MTCP-050-3BD18(C)	50		1473				94.5	0.855	14.1	0.78	
MTCP-060-3BD18(C)	60		1484				95.0	0.850	16.27	0.66	
MTCP-075-3BD18(C)	75		1483				95.4	0.850	18.8	0.69	
MTCP-100-3BD18(C)	100		1486				95.4	0.860	45.5	0.56	
MTCP-125-3BD18	125		1486				95.4	0.860	65.1	0.56	
MTCP-150-3BD18	150		1486				95.8	0.860	69.26	0.53	
MTCP-200-3BD18	200		1486				96.3	0.860	84.0	0.52	

1) Maximum Constant HP RPM is for direct-coupled loads.

Part Number (repeated)	HP	Current @ 200V/400V (Amps)			Torque (lb-ft)			Max Time @ Locked Rotor Current (hot)	Temperature Rise @ Full Load
		No Load	Full Load	Locked Rotor	Full Load	Locked Rotor	Break-down		
MTCP-001-3BD18(C)	1	2.62 / 1.31	3.70 / 1.85	34.5 / 17.3	3.61	10.8	13.7	20 seconds	80°C [176°F]
MTCP-1P5-3BD18(C)	1-1/2	3.59 / 1.80	5.34 / 2.67	46.0 / 23.0	5.40	10.8	16.7		
MTCP-002-3BD18(C)	2	4.10 / 2.10	6.90 / 3.50	57.5 / 28.8	7.20	20.9	23.0		
MTCP-003-3BD18(C)	3	4.70 / 2.35	9.26 / 4.63	73.6 / 36.8	10.8	24.8	30.2		
MTCP-005-3BD18(C)	5	7.13 / 3.57	15.42 / 7.71	106 / 52.9	18.1	41.6	52.5		
MTCP-7P5-3BD18(C)	7-1/2	9.71 / 4.86	21.5 / 10.7	146 / 73.0	27.0	54.0	83.7		
MTCP-010-3BD18(C)	10	12.1 / 6.06	28.6 / 14.3	187 / 93.7	36.1	74.0	112		
MTCP-015-3BD18(C)	15	17.7 / 8.85	41.2 / 20.6	267 / 133	54.2	111	152		
MTCP-020-3BD18(C)	20	19.7 / 9.84	55.1 / 27.6	334 / 167	71.5	143	200		
MTCP-025-3BD18(C)	25	27.6 / 13.8	68.5 / 34.3	420 / 210	89.4	188	224		
MTCP-030-3BD18(C)	30	31.1 / 15.5	80.5 / 40.2	500 / 250	107	246	300		
MTCP-040-3BD18(C)	40	34.0 / 17.0	109 / 54.5	667 / 334	142	298	327		
MTCP-050-3BD18(C)	50	41.6 / 20.8	134 / 67.2	834 / 417	178	392	498		
MTCP-060-3BD18(C)	60	52.4 / 26.2	160 / 80.1	1001 / 500	212	445	615		
MTCP-075-3BD18(C)	75	67.2 / 33.6	199 / 99.7	1248 / 624	266	559	745		
MTCP-100-3BD18(C)	100	86.3 / 43.1	263 / 132	1668 / 834	353	777	847	20 seconds	
MTCP-125-3BD18	125	109 / 54.4	328 / 164	2088 / 1044	442	751	1105	18 seconds	
MTCP-150-3BD18	150	126 / 63.2	414 / 207	2627 / 1314	530	954	1325		
MTCP-200-3BD18	200	153 / 77	521 / 261	3335 / 1668	707	1414	1980		

MTCP MOTOR PERFORMANCE DATA – CAST-IRON T-FRAME – 50Hz/1000RPM

Performance Data @ 50Hz – Premium Efficiency T-Frame 3-Phase Motors – 1000 rpm – (400 Volt except as indicated)											
Part Number	HP	NEMA Design	F.L. RPM	Speed (rpm)				F.L. Efficiency (%)	F.L. Power Factor	Rotor Inertia (lb-ft ²)	Slip (%)
				Minimum		Maximum					
				Constant Torque	Variable Torque	CHP(1)	Safe				
MTCP-001-3BD12	1	B	964	300	120	1800	3600	82.5	0.72	0.33	3.14
MTCP-1P5-3BD12	1-1/2		87.5					0.72	0.36	1.85	
MTCP-002-3BD12	2		88.5					0.74	0.47	2.00	
MTCP-003-3BD12	3		89.5					0.74	0.50	1.65	
MTCP-005-3BD12	5		89.5					0.76	1.97	1.85	
MTCP-7P5-3BD12	7-1/2		91.1					0.74	2.74	1.51	
MTCP-010-3BD12	10		91.0					0.74	2.98	1.56	
MTCP-015-3BD12	15		91.7					0.76	5.49	1.16	
MTCP-020-3BD12	20		91.7					0.78	12.9	1.21	

1) Maximum Constant HP RPM is for direct-coupled loads.

Part Number (repeated)	HP	Current @ 200V/400V (Amps)			Torque (lb-ft)			Max Time @ Locked Rotor Current (hot)	Temperature Rise @ Full Load
		No Load	Full Load	Locked Rotor	Full Load	Locked Rotor	Break-down		
MTCP-001-3BD12	1	2.88 / 1.44	3.63 / 1.82	34.5 / 17.3	5.40	13.0	17.3	20 seconds	80°C [176°F]
MTCP-1P5-3BD12	1-1/2	3.70 / 1.85	5.13 / 2.57	46.0 / 23.0	8.04	18.5	25.7		
MTCP-002-3BD12	2	4.83 / 2.42	6.58 / 3.29	57.5 / 28.8	10.7	25.7	37.1		
MTCP-003-3BD12	3	7.36 / 3.68	9.75 / 4.88	78.2 / 39.1	16.1	35.4	48.3		
MTCP-005-3BD12	5	10.6 / 5.29	15.8 / 7.91	106 / 52.9	26.8	59.0	80.4		
MTCP-7P5-3BD12	7-1/2	13.8 / 6.90	24.0 / 12.0	146 / 73.0	40.2	92.5	141		
MTCP-010-3BD12	10	12.4 / 6.21	32.0 / 16.0	186 / 93.2	53.6	118	129		
MTCP-015-3BD12	15	20.7 / 10.4	46.4 / 23.2	267 / 133	80.4	177	233		
MTCP-020-3BD12	20	20.4 / 10.2	60.2 / 30.1	334 / 167	107	235	310		

MTCP MOTOR PERFORMANCE DATA – CAST-IRON T-FRAME – 50Hz/3000RPM

Performance Data @ 50Hz – Premium Efficiency T-Frame 3-Phase Motors – 3000 rpm – (400 Volt except as indicated)											
Part Number	HP	NEMA Design	F.L. RPM	Speed (rpm)				F.L. Efficiency (%)	F.L. Power Factor	Rotor Inertia (lb-ft ²)	Slip (%)
				Minimum		Maximum					
				Constant Torque	Variable Torque	CHP(1)	Safe				
MTCP-1P5-3BD36	1-1/2	B	2963	1800	720	5400	5400	85.5	0.83	0.08	2.00
MTCP-002-3BD36	2		2922					86.6	0.82	0.10	2.20
MTCP-003-3BD36	3		2922					87.0	0.85	0.20	1.60
MTCP-005-3BD36	5		2963					89.0	0.84	0.22	1.46
MTCP-7P5-3BD36	7-1/2		2922					89.7	0.85	0.50	1.67
MTCP-010-3BD36	10		2947					90.3	0.85	1.20	1.40
MTCP-015-3BD36	15		2947					91.2	0.85	1.86	1.11
MTCP-020-3BD36	20		2963					91.2	0.85	2.01	0.97

1) Maximum Constant HP RPM is for direct-coupled loads.

Part Number (repeated)	HP	Current @ 200V/400V (Amps)			Torque (lb-ft)			Max Time @ Locked Rotor Current (hot)	Temperature Rise @ Full Load
		No Load	Full Load	Locked Rotor	Full Load	Locked Rotor	Break-down		
MTCP-1P5-3BD36	1-1/2	2.30 / 1.20	4.69 / 2.35	46.0 / 23.0	2.66	7.71	9.58	20 seconds	80°C [176°F]
MTCP-002-3BD36	2	3.60 / 1.80	6.20 / 3.10	57.5 / 28.8	3.60	10.8	14.4		
MTCP-003-3BD36	3	4.49 / 2.25	8.90 / 4.45	73.6 / 36.8	5.39	15.1	20.5		
MTCP-005-3BD36	5	5.98 / 2.99	14.5 / 7.25	106 / 46.0	8.88	19.5	27.5		
MTCP-7P5-3BD36	7-1/2	7.66 / 3.83	21.2 / 10.6	146 / 73.0	13.5	33.7	41.8		
MTCP-010-3BD36	10	10.1 / 5.04	28.1 / 14.1	188 / 93.8	17.8	44.5	60.5		
MTCP-015-3BD36	15	13.8 / 6.90	40.3 / 20.1	267 / 133	26.7	56.1	77.4		
MTCP-020-3BD36	20	17.3 / 8.63	53.4 / 26.7	334 / 167	35.4	74.4	103		

MTCP MOTOR DIMENSIONS

(DIMENSIONS = INCHES)

MTCP PREMIUM-EFFICIENCY T-FRAME THREE-PHASE MOTOR DIMENSIONS

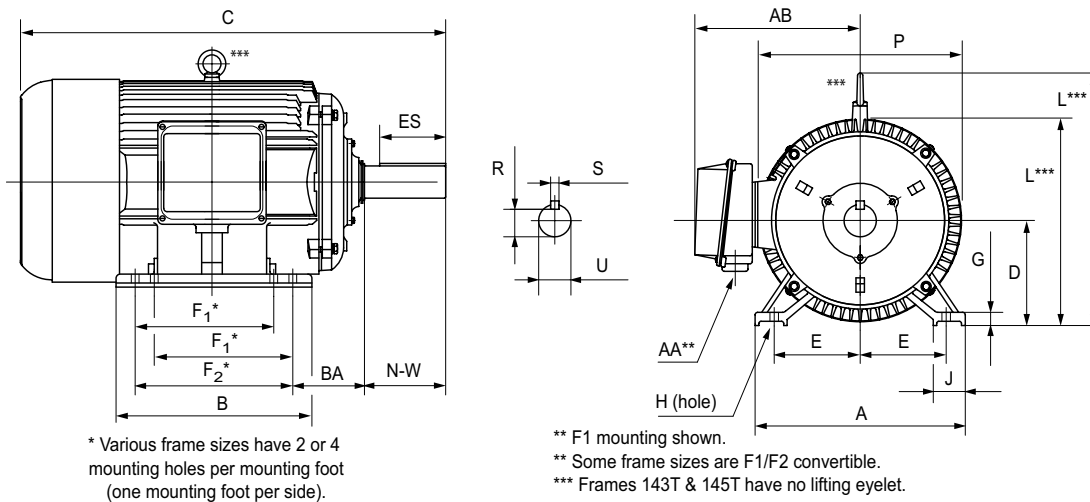

Dimensions [inches, except as noted] Premium-Efficiency Three-Phase T-Frame Motors – 1800 rpm											
Part Number	HP	NEMA Frame	A	AA**	AB	B	BA	C	D	E	ES
MTCP-001-3BD18	1	143T	7	3/4"npt	6.89	5.1	2.25	12.47	3.5	2.75	1.41
MTCP-1P5-3BD18	1-1/2	145T	7	3/4"npt	6.89	6.1	2.25	13.47	3.5	2.75	1.41
MTCP-002-3BD18	2		7	3/4"npt	6.89	6.1	2.25	13.47	3.5	2.75	1.41
MTCP-003-3BD18	3	182T	8.9	1" NPT	7.45	6.3	2.75	15.11	4.5	3.75	1.78
MTCP-005-3BD18	5	184T	8.9	1" NPT	7.45	7.1	2.75	16.12	4.5	3.75	1.78
MTCP-7P5-3BD18	7-1/2	213T	10.5	1" NPT	8.63	7.5	3.5	18.89	5.25	4.25	2.41
MTCP-010-3BD18	10	215T	10.5	1" NPT	8.63	9	3.5	20.49	5.25	4.25	2.41
MTCP-015-3BD18	15	254T	12.3	1.5" NPT	12.0	10.3	4.25	23.29	6.25	5	2.91
MTCP-020-3BD18	20	256T	12.3	1.5" NPT	12.0	12.4	4.25	25.06	6.25	5	2.91
MTCP-025-3BD18	25	284T	13.7	1.5" NPT	13.7	12.2	4.75	26.63	7	5.5	3.28
MTCP-030-3BD18	30	286T	13.7	1.5" NPT	13.7	13.7	4.75	28.18	7	5.5	3.28
MTCP-040-3BD18	40	324T	15.3	2"NPT	15.3	12.6	5.25	29.95	8	6.25	3.91
MTCP-050-3BD18	50	326T	15.3	2"NPT	15.3	14.0	5.25	31.24	8	6.25	3.91
MTCP-060-3BD18	60	364T	17.0	3"NPT	17.31	14.6	5.88	32.58	9	7	4.28
MTCP-075-3BD18	75	365T	17.0	3"NPT	17.31	15.6	5.88	34.11	9	7	4.28
MTCP-100-3BD18	100	405T	20	3"NPT	18.07	17.8	6.62	38.35	10	8	5.65
MTCP-125-3BD18	125	444T	22	2x3"NPT	19.07	18.5	7.5	42.52	11	9	6.91
MTCP-150-3BD18	150	445T	22	2x3"NPT	19.07	20.5	7.5	44.5	11	9	6.91
MTCP-200-3BD18	200	445/7T	22	2x3"NPT	19.07	24	7.5	48.03	11	9	6.91

* Various frame sizes have 2 or 4 mounting holes per mounting foot.
** AA dimension is conduit fitting size. F1 mounting shown; some frame sizes are F1/F2 convertible; refer to T-frame "Motor Specifications" table.
(F2 mounting = conduit entrance on right side facing shaft.)
*** Frame sizes 143T(C) and 145T(C) have no lifting eyelet.

**** TABLE CONTINUED NEXT PAGE (for dimensions F₁-U) ****

MTCP MOTOR DIMENSIONS (CONTINUED) – (DIMENSIONS = INCHES)

MTCP PREMIUM-EFFICIENCY T-FRAME THREE-PHASE MOTOR DIMENSIONS (CONTINUED)

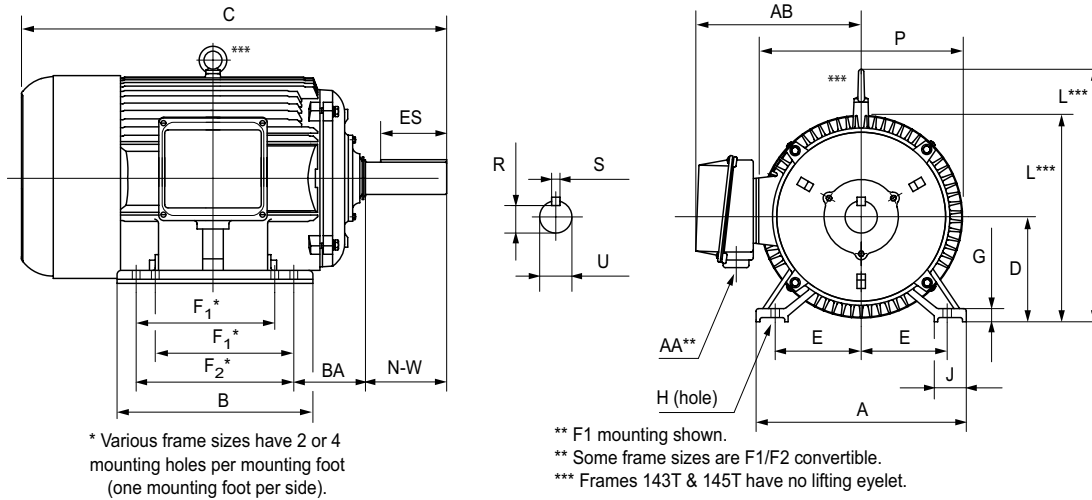

****** TABLE CONTINUED FROM PREVIOUS PAGE (for dimensions A–ES) ******

Dimensions [inches, except as noted]
Premium-Efficiency Three-Phase T-Frame Motors – 1800 rpm

Part Number	HP	F ₁ *	F ₂ *	G	H	J	N-W	L	P	R	S	U
MTCP-001-3BD18	1	n/a	4	0.47	0.34	1.45	2.25	6.90	7.2	0.771	0.188	0.875
MTCP-1P5-3BD18	1-1/2	4	5	0.47	0.34	1.45	2.25	6.90	7.2	0.771	0.188	0.875
MTCP-002-3BD18	2	4	5	0.47	0.34	1.45	2.25	6.90	7.2	0.771	0.188	0.875
MTCP-003-3BD18	3	n/a	4.5	0.52	0.41	1.97	2.75	10.39	9.0	0.986	0.25	1.125
MTCP-005-3BD18	5	4.5	5.5	0.52	0.41	1.97	2.75	10.39	9.0	0.986	0.25	1.125
MTCP-7P5-3BD18	7-1/2	n/a	5.5	0.78	0.41	2.36	3.38	12.26	10.8	1.201	0.312	1.375
MTCP-010-3BD18	10	5.5	7	0.78	0.41	2.36	3.38	12.26	10.8	1.201	0.312	1.375
MTCP-015-3BD18	15	n/a	8.25	0.87	0.53	2.40	4	15.10	14.4	1.416	0.375	1.625
MTCP-020-3BD18	20	8.25	10	0.87	0.53	2.40	4	15.10	14.4	1.416	0.375	1.625
MTCP-025-3BD18	25	n/a	9.5	0.98	0.53	2.68	4.62	16.50	16.0	1.591	0.5	1.875
MTCP-030-3BD18	30	9.5	11	0.98	0.53	2.68	4.62	16.50	16.0	1.591	0.5	1.875
MTCP-040-3BD18	40	n/a	10.5	0.98	0.66	2.76	5.25	18.25	17.5	1.845	0.5	2.125
MTCP-050-3BD18	50	10.5	12	0.98	0.66	2.76	5.25	18.25	17.5	1.845	0.5	2.125
MTCP-060-3BD18	60	n/a	11.25	1.10	0.66	3.15	5.88	21.0	19.1	2.021	0.625	2.375
MTCP-075-3BD18	75	11.25	12.25	1.10	0.66	3.15	5.88	21.0	19.1	2.021	0.625	2.375
MTCP-100-3BD18	100	12.25	13.75	1.18	0.81	3.15	7.25	23.46	21.4	2.45	0.75	2.875
MTCP-125-3BD18	125	n/a	14.5	1.38	0.81	3.35	8.5	26.43	23.4	2.88	0.875	3.375
MTCP-150-3BD18	150	14.5	16.5	1.38	0.81	3.35	8.5	26.43	23.4	2.88	0.875	3.375
MTCP-200-3BD18	200	16.5	20	1.38	0.81	3.35	8.5	26.43	23.4	2.88	0.875	3.375

* Various frame sizes have 2 or 4 mounting holes per mounting foot.
** AA dimension is conduit fitting size. F1 mounting shown; some frame sizes are F1/F2 convertible; refer to T-frame "Motor Specifications" table.
(F2 mounting = conduit entrance on right side facing shaft.)
*** Frame sizes 143T(C) and 145T(C) have no lifting eyelet.

MTCP MOTOR DIMENSIONS (CONTINUED) – (DIMENSIONS = INCHES)

MTCP PREMIUM-EFFICIENCY T-FRAME THREE-PHASE MOTOR DIMENSIONS (CONTINUED)

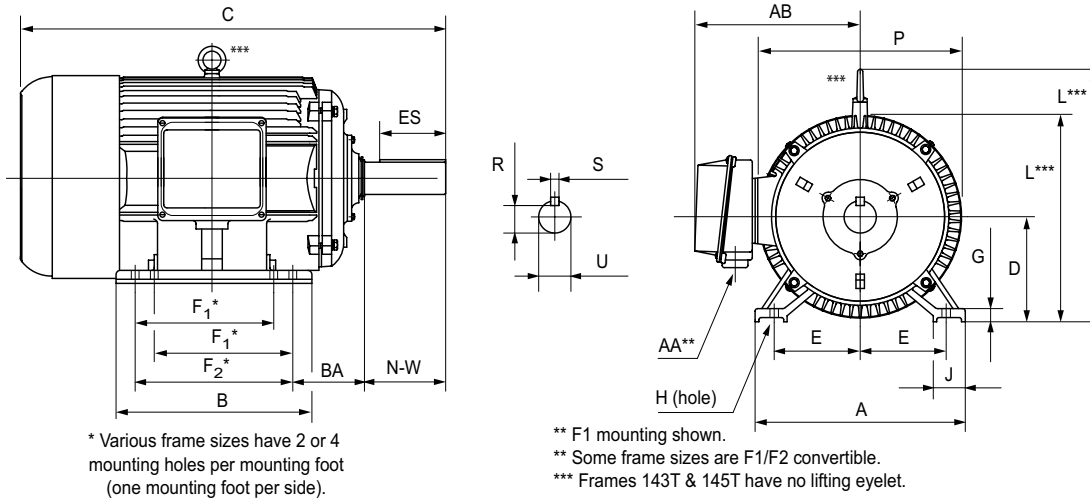

Dimensions [inches, except as noted]											
Premium-Efficiency Three-Phase T-Frame Motors – 1200 & 3600 rpm											
Part Number	HP	NEMA Frame	A	AA**	AB	B	BA	C	D	E	ES
1200 rpm Motors											
MTCP-001-3BD12	1	145T	7	3/4" NPT	6.89	6.1	2.25	13.47	3.5	2.75	1.41
MTCP-1P5-3BD12	1-1/2	182T	8.9	1" NPT	7.45	6.3	2.75	15.11	4.5	3.75	1.78
MTCP-002-3BD12	2	184T	8.9	1" NPT	7.45	7.1	2.75	16.12	4.5	3.75	1.78
MTCP-003-3BD12	3	213T	10.5	1" NPT	8.63	7.5	3.5	18.89	5.25	4.25	2.41
MTCP-005-3BD12	5	215T	10.5	1" NPT	8.63	9	3.5	20.49	5.25	4.25	2.41
MTCP-7P5-3BD12	7-1/2	254T	12.3	1.5" NPT	12.0	10.3	4.25	23.29	6.25	5	2.91
MTCP-010-3BD12	10	256T	12.3	1.5" NPT	12.0	12.4	4.25	25.06	6.25	5	2.91
MTCP-015-3BD12	15	284T	13.7	1.5" NPT	13.7	12.2	4.75	26.63	7	5.5	3.28
MTCP-020-3BD12	20	286T	13.7	1.5" NPT	13.7	13.7	4.75	28.18	7	5.5	3.28
3600 rpm Motors											
MTCP-1P5-3BD36	1-1/2	143T	7	3/4" NPT	6.89	5.1	2.25	12.47	3.5	2.75	1.41
MTCP-002-3BD36	2	145T	7	3/4" NPT	6.89	6.1	2.25	13.47	3.5	2.75	1.41
MTCP-003-3BD36	3	182T	8.9	1" NPT	7.45	6.3	2.75	15.11	4.5	3.75	1.78
MTCP-005-3BD36	5	184T	8.9	1" NPT	7.45	7.1	2.75	16.12	4.5	3.75	1.78
MTCP-7P5-3BD36	7-1/2	213T	10.5	1" NPT	8.63	7.5	3.5	18.89	5.25	4.25	2.41
MTCP-010-3BD36	10	215T	10.5	1" NPT	8.63	9	3.5	20.49	5.25	4.25	2.41
MTCP-015-3BD36	15	254T	12.3	1.5" NPT	12.0	10.3	4.25	23.29	6.25	5	2.91
MTCP-020-3BD36	20	256T	12.3	1.5" NPT	12.0	12.4	4.25	25.06	6.25	5	2.91
* Various frame sizes have 2 or 4 mounting holes per mounting foot.											
** AA dimension is conduit fitting size. F1 mounting shown; some frame sizes are F1/F2 convertible; refer to T-frame "Motor Specifications" table. (F2 mounting = conduit entrance on right side facing shaft.)											
*** Frame sizes 143T(C) and 145T(C) have no lifting eyelet.											
**** TABLE CONTINUED NEXT PAGE (for dimensions F1-U) ****											

MTCP MOTOR DIMENSIONS (CONTINUED) – (DIMENSIONS = INCHES)

MTCP PREMIUM-EFFICIENCY T-FRAME THREE-PHASE MOTOR DIMENSIONS (CONTINUED)

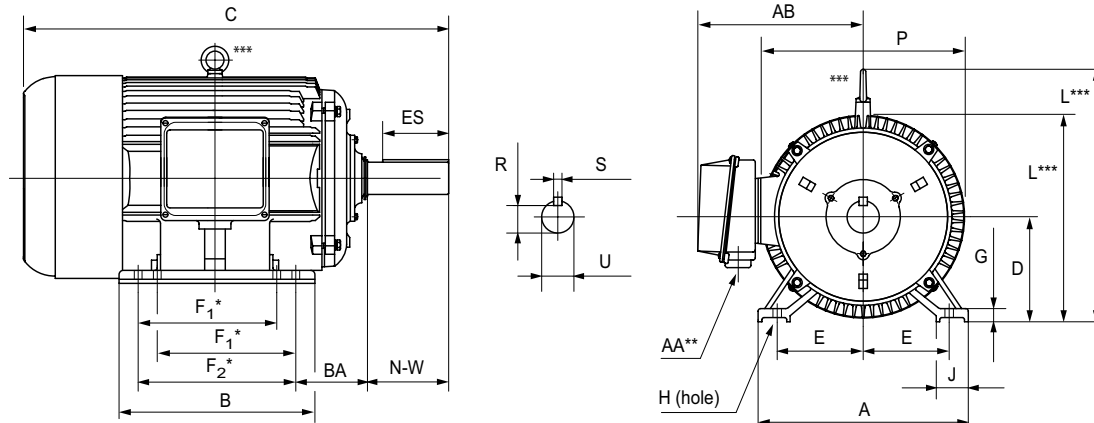

* Various frame sizes have 2 or 4 mounting holes per mounting foot (one mounting foot per side).

** F1 mounting shown.
 ** Some frame sizes are F1/F2 convertible.
 *** Frames 143T & 145T have no lifting eyelet.

**** TABLE CONTINUED FROM PREVIOUS PAGE (for dimensions A–ES) ****

Dimensions [inches, except as noted]												
Premium-Efficiency Three-Phase T-Frame Motors – 1200 & 3600 rpm												
Part Number	HP	F ₁ *	F ₂ *	G	H	J	N-W	L	P	R	S	U
1200 rpm Motors												
MTCP-001-3BD12	1	4	5	0.47	0.34	1.45	2.25	6.90	7.2	0.771	0.188	0.875
MTCP-1P5-3BD12	1-1/2	n/a	4.5	0.52	0.41	1.97	2.75	10.39	9.0	0.986	0.25	1.125
MTCP-002-3BD12	2	4.5	5.5	0.52	0.41	1.97	2.75	10.39	9.0	0.986	0.25	1.125
MTCP-003-3BD12	3	n/a	5.5	0.78	0.41	2.36	3.38	12.26	10.8	1.201	0.312	1.375
MTCP-005-3BD12	5	5.5	7	0.78	0.41	2.36	3.38	12.26	10.8	1.201	0.312	1.375
MTCP-7P5-3BD12	7-1/2	n/a	8.25	0.87	0.53	2.40	4	15.10	14.4	1.416	0.375	1.625
MTCP-010-3BD12	10	8.25	10	0.87	0.53	2.40	4	15.10	14.4	1.416	0.375	1.625
MTCP-015-3BD12	15	n/a	9.5	0.98	0.53	2.68	4.62	16.50	16.0	1.591	0.5	1.875
MTCP-020-3BD12	20	9.5	11	0.98	0.53	2.68	4.62	16.50	16.0	1.591	0.5	1.875
3600 rpm Motors												
MTCP-1P5-3BD36	1-1/2	n/a	4	0.47	0.34	1.45	2.25	6.90	7.2	0.771	0.188	0.875
MTCP-002-3BD36	2	4	5	0.47	0.34	1.45	2.25	6.90	7.2	0.771	0.188	0.875
MTCP-003-3BD36	3	n/a	4.5	0.52	0.41	1.97	2.75	10.39	9.0	0.986	0.25	1.125
MTCP-005-3BD36	5	4.5	5.5	0.52	0.41	1.97	2.75	10.39	9.0	0.986	0.25	1.125
MTCP-7P5-3BD36	7-1/2	n/a	5.5	0.78	0.41	2.36	3.38	12.26	10.8	1.201	0.312	1.375
MTCP-010-3BD36	10	5.5	7	0.78	0.41	2.36	3.38	12.26	10.8	1.201	0.312	1.375
MTCP-015-3BD36	15	n/a	8.25	0.87	0.53	2.40	4	15.10	14.4	1.416	0.375	1.625
MTCP-020-3BD36	20	8.25	10	0.87	0.53	2.40	4	15.10	14.4	1.416	0.375	1.625

* Various frame sizes have 2 or 4 mounting holes per mounting foot.
 ** AA dimension is conduit fitting size. F1 mounting shown; some frame sizes are F1/F2 convertible; refer to T-frame "Motor Specifications" table.
 (F2 mounting = conduit entrance on right side facing shaft.)
 *** Frame sizes 143T(C) and 145T(C) have no lifting eyelet.

MTCP MOTOR DIMENSIONS (CONTINUED) – (DIMENSIONS = INCHES)

MTCP PREMIUM-EFFICIENCY TC-FRAME THREE-PHASE MOTOR DIMENSIONS

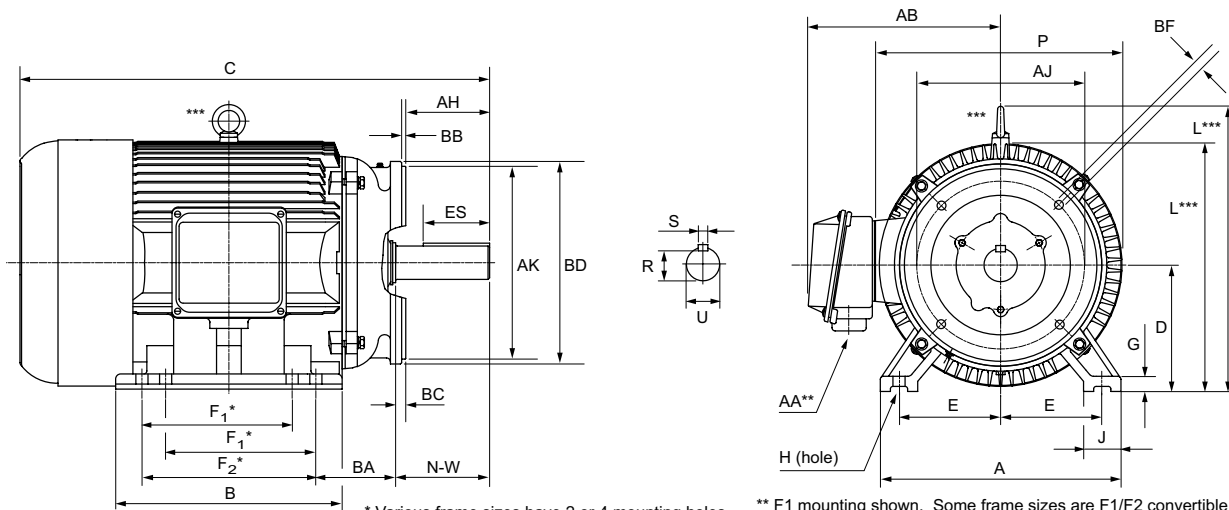

* Various frame sizes have 2 or 4 mounting holes per mounting foot (one mounting foot per side).
 ** F1 mounting shown. Some frame sizes are F1/F2 convertible.
 *** Frames 143TC and 145TC have no lifting eyelet.

Dimensions [inches, except as noted]															
Premium-Efficiency Three-Phase TC-Frame Motors – 1800 rpm															
Part # MTCP- xxx- 3BD18C	HP	NEMA Frame	A	AA**	AB	AH	AJ	AK	B	BA	BB	BC	BD	BF	C
-001-	1	143TC	7	3/4" NPT	6.89	1.96	5.875	4.5	5.1	2.25	0.16	0.29	6.5	3/8-16	12.5
-1P5-	1-1/2	145TC	7	3/4" NPT	6.89	1.96	5.875	4.5	6	2.25	0.16	0.29	6.5	3/8-16	13.5
-002-	2														
-003-	3	182TC	8.9	1" NPT	7.45	2.37	7.25	8.5	6.3	2.75	0.25	0.38	9	1/2-13	15.1
-005-	5	184TC	8.9	1" NPT	7.45	2.37	7.25	8.5	7.1	2.75	0.25	0.38	9	1/2-13	16.1
-7P5-	7-1/2	213TC	10.5	1" NPT	8.63	2.87	7.25	8.5	7.5	3.5	0.25	0.51	9	1/2-13	18.9
-010-	10	215TC	10.5	1" NPT	8.63	2.87	7.25	8.5	9	3.5	0.25	0.51	9	1/2-13	20.5
-015-	15	254TC	12.3	1.5" NPT	12.0	3.75	7.25	8.5	10.3	4.25	0.25	0.25	10	1/2-13	23.3
-020-	20	256TC	12.3	1.5" NPT	12.0	3.75	7.25	8.5	12.4	4.25	0.25	0.25	10	1/2-13	25.1
-025-	25	284TC	13.7	1.5" NPT	13.7	4.38	9	10.5	12.2	4.75	0.25	0.25	11.25	1/2-13	26.6
-030-	30	286TC	13.7	1.5" NPT	13.7	4.38	9	10.5	13.7	4.75	0.25	0.24	11.25	1/2-13	28.2
-040-	40	324TC	15.3	2" NPT	15.3	5	11	12.5	12.6	5.25	0.25	0.24	14	5/8-11	30.0
-050-	50	326TC	15.3	2" NPT	15.3	5	11	12.5	14.0	5.25	0.25	0.25	14	5/8-11	31.2
-060-	60	364TC	17.0	3" NPT	17.3	5.62	11	12.5	14.6	5.88	0.25	0.25	14	5/8-11	32.6
-075-	75	365TC	17.0	3" NPT	17.3	5.62	11	12.5	15.6	5.88	0.25	0.25	14	5/8-11	34.1
-100-	100	405TC	20	3" NPT	18.1	7	11	12.5	17.8	6.62	0.25	0.25	15.5	5/8-11	38.4

* Various frame sizes have 2 or 4 mounting holes per mounting foot.
 ** AA dimension is conduit fitting size. F1 mounting shown; some frame sizes are F1/F2 convertible; refer to T-frame "Motor Specifications" table.
 (F2 mounting = conduit entrance on right side facing shaft.)
 *** Frame sizes 143T(C) and 145T(C) have no lifting eyelet.
 **** TABLE CONTINUED NEXT PAGE (for dimensions D-U) ****

MTCP MOTOR DIMENSIONS (CONTINUED) – (DIMENSIONS = INCHES)

MTCP PREMIUM-EFFICIENCY TC-FRAME THREE-PHASE MOTOR DIMENSIONS (CONTINUED)

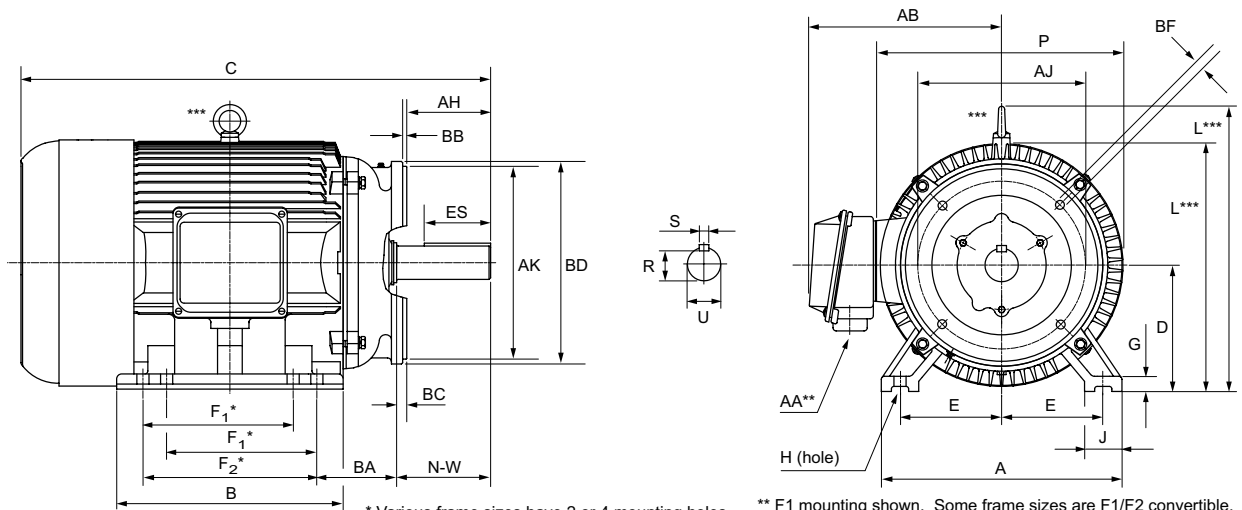

* Various frame sizes have 2 or 4 mounting holes per mounting foot (one mounting foot per side).

** F1 mounting shown. Some frame sizes are F1/F2 convertible.

*** Frames 143TC and 145TC have no lifting eyelet.

**** TABLE CONTINUED FROM PREVIOUS PAGE (for dimensions A–C) ****

Dimensions [inches, except as noted]															
Premium-Efficiency Three-Phase TC-Frame Motors – 1800 rpm															
Part # MTCP- xxx- 3BD18C	HP	D	E	ES	F ₁ *	F ₂ *	G	H	J	N-W	L	P	R	S	U
-001-	1	3.5	2.75	1.41	n/a	4	0.47	0.34	1.45	2.25	6.9	7.2	0.771	0.188	0.875
-1P5-	1-1/2	3.5	2.75	1.41	4	5	0.47	0.34	1.45	2.25	6.9	7.2	0.771	0.188	0.875
-002-	2														
-003-	3	4.5	3.75	1.78	n/a	4.5	0.52	0.41	1.97	2.75	10.4	9.0	0.986	0.25	1.125
-005-	5	4.5	3.75	1.78	4.5	5.5	0.52	0.41	1.97	2.75	10.4	9.0	0.986	0.25	1.125
-7P5-	7-1/2	5.25	4.25	2.41	n/a	5.5	0.78	0.41	2.36	3.38	12.3	10.8	1.201	0.312	1.375
-010-	10	5.25	4.25	2.41	5.5	7	0.78	0.41	2.36	3.38	12.3	10.8	1.201	0.312	1.375
-015-	15	6.25	5	2.91	n/a	8.25	0.87	0.53	2.40	4	15.1	14.4	1.416	0.375	1.625
-020-	20	6.25	5	2.91	8.25	10	0.87	0.53	2.40	4	15.1	14.4	1.416	0.375	1.625
-025-	25	7	5.5	3.28	n/a	9.5	0.98	0.53	2.68	4.62	16.5	16.0	1.591	0.5	1.875
-030-	30	7	5.5	3.28	9.5	11	0.98	0.53	2.68	4.62	16.5	16.0	1.591	0.5	1.875
-040-	40	8	6.25	3.91	n/a	10.5	0.98	0.66	2.76	5.25	18.3	17.5	1.854	0.5	2.125
-050-	50	8	6.25	3.91	10.5	12	0.98	0.66	2.76	5.25	18.3	17.5	1.845	0.5	2.125
-060-	60	9	7	4.28	n/a	11.25	1.10	0.66	3.15	5.88	21.0	19.1	2.021	0.625	2.375
-075-	75	9	7	4.28	11.25	12.25	1.10	0.66	3.15	5.88	21.0	19.1	2.021	0.625	2.375
-100-	100	10	8	5.65	12.25	13.75	1.18	0.81	3.15	7.25	23.5	21.4	2.45	0.75	2.875

* Various frame sizes have 2 or 4 mounting holes per mounting foot.
 ** AA dimension is conduit fitting size. F1 mounting shown; some frame sizes are F1/F2 convertible; refer to T-frame "Motor Specifications" table.
 (F2 mounting = conduit entrance on right side facing shaft.)
 *** Frame sizes 143T(C) and 145T(C) have no lifting eyelet.

MTCP JUNCTION BOX DIMENSIONS

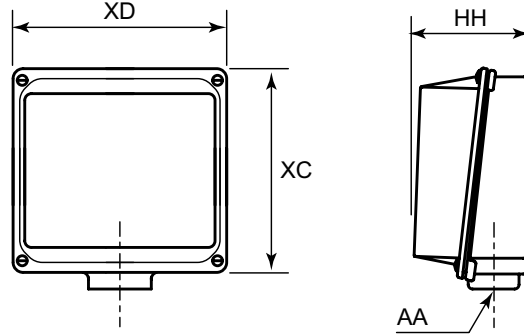

Junction Box Dimensions (in)				
Frame Size *	XD (Width)	XC (Height)	HH (Depth)	AA (Conduit Hole (NPT))
143T	11.3	4.5	2.3	3/4
145T		5.0	2.5	1
182T				
184T				
213T				
215T				
254T		7.3	3.3	1-1/2
256T				
284T				
286T		10.4	6.0	2
324T				
326T		10.8	5.3	3
364T				
365T				
405T		11.7	7.1	3 (2 openings)
444T				
445T				
445/7T				
449T				

* TC-frame motors have the same junction boxes as the comparable T-frame motors.

MTCP DECIBEL LEVELS

The decibel (sound) level of an IronHorse® motor should be measured after initial startup, after 30 days, and after six months of use. Decibel levels should remain fairly consistent and can be an indication of misalignment and premature bearing wear. If the measured decibel level for your IronHorse model exceeds the value listed below by more than 10%, contact AutomationDirect or a local motor service technician found at www.easa.com.

MTCP Average T-Frame Decibel Levels		
Frame Size *	HP	Noise Level: Lw dB(A) @ 1m
		MTCP
143T	1	70.0
145T	1-1/2	70.0
	2	70.0
182T	2	–
182T	3	74.0
184T	5	74.0
213T	7-1/2	79.0
215T	10	79.0
254T	15	84.0
256T	20	84.0
284T	25	88.0
286T	30	88.0
324T	40	89.0
326T	50	89.0
364T	60	95.0
365T	75	95.0
405T	100	98.0
444T	125	100
445T	150	100
445/7T	200	103
449T	250	105.0
	300	105.0

* TC-frame motors have the same sound ratings as the comparable T-frame motors.

SPARE/REPLACEMENT PARTS FOR MTCP PREMIUM-EFFICIENCY THREE-PHASE MOTORS

IronHorse junction boxes, TEFC fans, and TEFC fan shrouds are available as direct replacement parts for MTCP motors.

These parts are field installable, and include installation instructions.



MTCP Premium-Efficiency Three-Phase Motor Replacement Parts					
Part Number (1)	Description (2)(3)(4)	Fits Frame	Fits PE Motor Number (1)	Motor HP	Product Weight (lb)
MTAP-FAN-140	Replacement Fan	143 & 145	MTCP-001-3BD12	1	0.3
MTAP-SHROUD-140	Replacement Fan Shroud		MTCP-001-3BD18(C)	1	1.1
MTAP-JBOX-140	Replacement Junction Box		MTCP-1P5-3BD18(C)	1-1/2	
			MTCP-1P5-3BD36	1-1/2	
MTAP-FAN-180	Replacement Fan	182 & 184	MTCP-002-3BD18(C)	2	2.6
	Replacement Fan Shroud		MTCP-002-3BD36	2	
MTAP-JBOX-180	Replacement Junction Box		MTCP-1P5-3BD12	1-1/2	0.3
			MTCP-002-3BD12	2	
MTAP-FAN-210-2	Replacement Fan (for 2-pole motors)	213 & 215	MTCP-003-3BD18(C)	3	1.5
	Replacement Fan Shroud		MTCP-003-3BD36	3	
MTAP-FAN-210	Replacement Fan (4&6-pole)		MTCP-005-3BD18(C)	5	3.1
	Replacement Fan Shroud		MTCP-005-3BD36	5	
MTAP-JBOX-210	Replacement Junction Box	MTCP-7P5-3BD36	7-1/2	0.3	
		MTCP-010-3BD36	10		
MTAP-FAN-210	Replacement Fan (4&6-pole)	213 & 215	MTCP-003-3BD12	3	0.3
			MTCP-005-3BD12	5	
MTAP-SHROUD-210	Replacement Fan Shroud		MTCP-7P5-3BD18(C)	7-1/2	2.3
			MTCP-010-3BD18(C)	10	
MTAP-JBOX-210	Replacement Junction Box				3.4

1) These MTAP replacement components fit only MTCP Premium-Efficiency motors; they will NOT fit MTC EPart motors.
 2) Replacement Fans include fan, snap ring, and instructions.
 3) Replacement Fan Shrouds include shroud, bolts w/washers, rubber plug, and instructions.
 4) Replacement Junction Boxes include gasketed base & cover assembly, base gasket, base bolts, and instructions.

*** TABLE CONTINUED NEXT PAGE ***

SPARE/REPLACEMENT PARTS FOR MTCP PREMIUM-EFFICIENCY 3-PHASE MOTORS (CONTINUED)

*** TABLE CONTINUED FROM PREVIOUS PAGE ***					
MTCP Premium-Efficiency Three-Phase Motor Replacement Parts					
Part Number (1)	Description (2)(3)(4)	Fits Frame	Fits PE Motor Number (1)	Motor HP	Product Weight (lb)
MTAP-FAN-250-2	Replacement Fan (for 2-pole motors)	254 & 256	MTCP-015-3BD36 MTCP-020-3BD36	15 20	0.3
MTAP-FAN-250	Replacement Fan (4&6-pole)		MTCP-7P5-3BD12	7-1/2	0.3
MTAP-SHROUD-250	Replacement Fan Shroud		MTCP-010-3BD12	10	4.5
MTAP-JBOX-250	Replacement Junction Box		MTCP-015-3BD18(C) MTCP-020-3BD18(C)	15 20	7.0
MTAP-FAN-280	Replacement Fan	284 & 286	MTCP-015-3BD12	15	0.5
MTAP-SHROUD-280	Replacement Fan Shroud		MTCP-020-3BD12	20	6.5
MTAP-JBOX-280	Replacement Junction Box		MTCP-025-3BD18(C) MTCP-030-3BD18(C)	25 30	7.0
MTAP-FAN-320	Replacement Fan	324 & 326	MTCP-040-3BD18(C)	40	0.6
MTAP-SHROUD-320	Replacement Fan Shroud		MTCP-050-3BD18(C)	50	8.3
MTAP-JBOX-320	Replacement Junction Box				22.3
MTAP-FAN-360	Replacement Fan	364 & 365	MTCP-060-3BD18(C)	60	0.6
MTAP-SHROUD-360	Replacement Fan Shroud		MTCP-075-3BD18(C)	75	9.0
MTAP-JBOX-360	Replacement Junction Box				22.3
MTAP-FAN-400	Replacement Fan	405	MTCP-100-3BD18(C)	100	1.1
MTAP-SHROUD-400	Replacement Fan Shroud				15.8
MTAP-JBOX-400	Replacement Junction Box				30.0
MTAP-FAN-440	Replacement Fan	444 & 447	MTCP-125-3BD18	125	2.0
MTAP-SHROUD-440	Replacement Fan Shroud		MTCP-150-3BD18	150	17.5
MTAP-JBOX-440	Replacement Junction Box		MTCP-200-3BD18	200	40.0

1) These MTAP replacement components fit only MTCP Premium-Efficiency motors; they will NOT fit MTC EPart motors.
 2) Replacement Fans include fan, snap ring, and instructions.
 3) Replacement Fan Shrouds include shroud, bolts w/washers, rubber plug, and instructions.
 4) Replacement Junction Boxes include gasketed base & cover assembly, base gasket, base bolts, and instructions.

MTCP BEARING SIZE INFORMATION

All IronHorse® cast-iron motors use premium name-brand bearings (NSK, NTN, or SKF). Below is a bearing size chart listing the type of bearings used in each frame size of IronHorse MTCP motors. The bearing types are also listed on the motor nameplate.

MTCP Bearing Size Chart		
Frame Size *	Drive End Bearing	Opposite Drive End Bearing
143T	6205-ZZ	6205-ZZ
145T		
182T	6306-ZZ	6306-ZZ
184T		
213T	6308-ZZ	6306-ZZ
215T		
254T	6309	6308
256T		
284T	6311	6309
286T		
324T	6312	6312
326T		
364T	6313	6312
365T		
404T	NU316	-
405T		6313
444T	NU318	6314
445T		
445/7T	NU319	
449T	NU320	-

* TC-frame motors have the same bearings as the comparable T-frame motors.

MTR SERIES MOTORS

MTR FEATURES AND SPECIFICATIONS (SINGLE-PHASE MOTORS)

IronHorse® single-phase 56C/56HC-frame* motors are available from 1/3 hp to 2 hp. All models have a TEFC rolled steel frame, cast aluminum end bell and removable mounting bases.

MTR ROLLED-STEEL 56C-FRAME 1-PHASE MOTOR SPECIFICATIONS

Motor Specifications – Single-Phase 56C/56HC-Frame Motors (60Hz except as indicated)									
Part Number	HP	Base RPM	Voltage	Service Factor	NEMA Design	NEMA Frame	Housing	F.L. Amps @ 115V/230V 60Hz	Approx Weight (lb)
	@ 60Hz								
1800 RPM									
MTR-P33-1AB18	1/3	1800	115/208-230	1.15	N	56C flange mount	IP43 TEFC rolled steel frame	6.6 / 3.3	26
MTR-P50-1AB18	1/2						Cast AL end bell	8.8 / 4.4	28
MTR-P75-1AB18	3/4						F1 conduit box location	11.0 / 5.5	32
MTR-001-1AB18	1							13.6 / 6.8	38
MTR-1P5-1AB18	1-1/2							15.2 / 7.6	45
3600 RPM									
MTR-1P5-1AB36	1-1/2	3600	115/208-230	1.15	N	56C	IP43 TEFC rolled steel frame Cast AL end bell F1 conduit box location	14.2 / 7.1	37

Note: Please review the AutomationDirect Terms & Conditions for warranty and service on this product.



NOTE: *56HC are suitable for 56C C-face mounting or 56, 143T, or 145T frame foot mounting dimensions.

MTR ROLLED-STEEL 56C-FRAME 1-PHASE MOTOR PERFORMANCE DATA

Performance Data – Single-Phase 56C/56HC-Frame Motors (230V / 60Hz data except as indicated)											
Part Number	HP	F.L. RPM	Current @ 115V/230V (Amps)			Torque (lb-ft)			F.L. Efficiency (%)	F.L. Power Factor	Rotor Inertia (lb-ft ²)
	@ 60Hz	230V No Load	Full Load	Locked Rotor	Full Load	Locked Rotor	Break down				
1800 RPM											
MTR-P33-1AB18	1/3	1725	2.2	6.6 / 3.3	31 / 18	1.02	3.06	2.81	56.0	0.62	0.075
MTR-P50-1AB18	1/2		2.93	8.8 / 4.4	37 / 21	1.52	4.56	4.18	57.0	0.63	0.080
MTR-P75-1AB18	3/4		3.67	11.0 / 5.5	55 / 32	2.29	6.30	5.73	65.0	0.65	0.095
MTR-001-1AB18	1		4.53	13.6 / 6.8	75 / 43	3.04	8.36	7.60	68.0	0.66	0.120
MTR-1P5-1AB18	1-1/2		5.07	15.2 / 7.6	120 / 65	4.57	11.43	10.28	71.0	0.75	0.142
3600 RPM											
MTR-1P5-1AB36	1-1/2	3450	3.0	14.2 / 7.1	116 / 58	2.2	7.5	5.4	72.0	0.9	0.03

MTR FEATURES AND SPECIFICATIONS (THREE-PHASE MOTORS)

IronHorse® rolled steel 56C/56HC-frame* three-phase motors are available from 1/3 hp to 3 hp. All models have a TEFC frame, cast aluminum end bell and removable mounting bases.

MTR ROLLED-STEEL 56C/56HC-FRAME 3-PHASE MOTOR SPECIFICATIONS – 1800 & 3600 RPM

Motor Specifications – MTR 3-Phase 56C/56HC-Frame Motors – 1800 & 3600 rpm									
Part Number	HP	Base RPM	Voltage	Service Factor	NEMA Design	NEMA Frame	Housing	F.L. Amps @ 230V/460V	Approx Weight (lb)
1800 RPM									
MTR-P33-3BD18	1/3	1800	208-230/460	1.15	B	56C flange mount	TEFC rolled steel frame Cast aluminum end bell F1 conduit box location	1.6 / 0.8	23
MTR-P50-3BD18	1/2							2.0 / 1.0	24
MTR-P75-3BD18	3/4							2.8 / 1.4	26
MTR-001-3BD18	1							3.6 / 1.8	29
MTR-1P5-3BD18	1-1/2							4.8 / 2.4	33
MTR-002-3BD18	2							6.0 / 3.0	42
3600 RPM									
MTR-P33-3BD36	1/3	3600	208-230/460	1.15	B	56C flange mount	TEFC rolled steel frame Cast aluminum end bell F1 conduit box location	1.6 / 0.8	23
MTR-P50-3BD36	1/2							2.2 / 1.1	24
MTR-P75-3BD36	3/4							2.9 / 1.5	26
MTR-001-3BD36	1							3.6 / 1.8	28
MTR-1P5-3BD36	1-1/2							4.6 / 2.3	34
MTR-002-3BD36	2							6.0 / 3.0	43
Note: Please review the AutomationDirect Terms & Conditions for warranty and service on this product.									



NOTE: *56HC are suitable for 56C C-face mounting or 56, 143T, or 145T frame foot mounting dimensions.

MTR ROLLED-STEEL 56C/56HC-FRAME THREE-PHASE MOTORS FEATURES AND SPECIFICATIONS (CONTINUED)

MTR MOTOR PERFORMANCE DATA – 1800 RPM

Performance Data – MTR/MTR2 Three-Phase 56C/56HC-Frame Motors – 1800 rpm (460V data except as indicated)									
Part Number	HP	F.L. RPM	Minimum Speed (rpm)		Maximum Speed (rpm)		Current @ 230V/460V (Amps)		
			CT	VT	CHP*	Safe	No Load	Full Load	Locked Rotor
MTR-P33-3BD18	1/3	1725	863	345	2700	5400	0.53 / 0.27	1.6 / 0.8	8 / 4
MTR-P50-3BD18	1/2						0.67 / 0.33	2.0 / 1.0	12 / 6
MTR-P75-3BD18	3/4						0.93 / 0.47	2.8 / 1.4	18 / 9
MTR-001-3BD18	1						1.2 / 0.6	3.6 / 1.8	24 / 12
MTR-1P5-3BD18	1-1/2	1725	863	345		5400	1.5 / 0.8	4.8 / 2.4	36 / 18
MTR-002-3BD18	2	1725	863	345		5400	2.0 / 1.0	6.0 / 3.0	48 / 24
Part Number	HP		Torque (lb-ft)				F.L. Efficiency (%)	F.L. Power Factor	Rotor Inertia (lb-ft ²)
			Full Load	Locked Rotor	Break-down				
MTR-P33-3BD18	1/3	n/a	1.02	2.55	2.81	n/a	67.0	0.70	0.058
MTR-P50-3BD18	1/2		1.52	3.80	4.18		69.0	0.72	0.068
MTR-P75-3BD18	3/4		2.29	5.73	6.30		71.0	0.74	0.075
MTR-001-3BD18	1		3.02	7.55	8.31		73.0	0.76	0.086
MTR-1P5-3BD18	1-1/2		4.57	10.28	11.43		75.0	0.78	0.108
MTR-002-3BD18	2		6.09	13.70	15.23		77.0	0.80	0.143

* Maximum Constant HP rpm is for direct-coupled loads.

MTR MOTOR PERFORMANCE DATA – 3600 RPM

Performance Data – Three-Phase 56C/56HC-Frame Motors – 3600 rpm (460V data except as indicated)									
Part Number	HP	F.L. RPM	Minimum Speed (rpm)		Maximum Speed (rpm)		Current @ 230V/460V (Amps)		
			CT	VT	CHP*	Safe	No Load	Full Load	Locked Rotor
MTR-P33-3BD36	1/3	3450	1725	690	5400	5400	1.2 / 0.59	1.6 / 0.8	9 / 5
MTR-P50-3BD36	1/2						1.4 / 0.7	2.2 / 1.1	14 / 7
MTR-P75-3BD36	3/4						1.5 / 0.75	2.9 / 1.5	17 / 8.9
MTR-001-3BD36	1	3450					1.7 / 0.85	3.6 / 1.8	25 / 13
MTR-1P5-3BD36	1-1/2	3450	1725	690			1.8 / 0.9	4.6 / 2.3	29 / 17
MTR-002-3BD36	2	3450	1725	690			3.4 / 1.7	6.0 / 3.0	57 / 30
MTRP-002-3BD36		3500	875	350			2.28 / 1.14	5.22 / 2.61	53/27
Part Number	HP		Torque (lb-ft)				F.L. Efficiency (%)	F.L. Power Factor	Rotor Inertia (lb-ft ²)
			Full Load	Locked Rotor	Break-down				
MTR-P33-3BD36	1/3	n/a	0.50	3.0	3.0	n/a	57.0	0.71	0.084
MTR-P50-3BD36	1/2		0.75	4.4	4.5		62.0	0.71	0.095
MTR-P75-3BD36	3/4		1.13	6.0	5.8		67.0	0.78	0.107
MTR-001-3BD36	1		1.50	7.9	7.1		69.0	0.82	0.122
MTR-1P5-3BD36	1-1/2		2.25	11.2	8.4		72.0	0.85	0.143
MTR-002-3BD36	2		3.06	18.9	13.4		75.0	0.78	0.188

* Maximum Constant HP rpm is for direct-coupled loads.

MTR MOTOR DIMENSIONS

(DIMENSIONS = INCHES)

MTR 56C-FRAME SINGLE-PHASE ROLLED-STEEL MOTOR DIMENSIONS

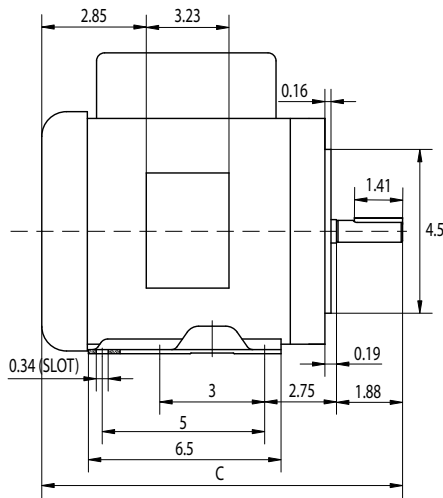

C = 12.4 in; all except 1 & 1.5 hp motors
 C = 13 in; 1 hp (1800 rpm) & 1.5 hp (3600 rpm)
 C = 13.8 in; 1.5 hp (1800 rpm)

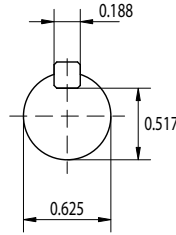

MTR-xxx-1ABxx IronHorse Motors
 (single-phase rolled steel)

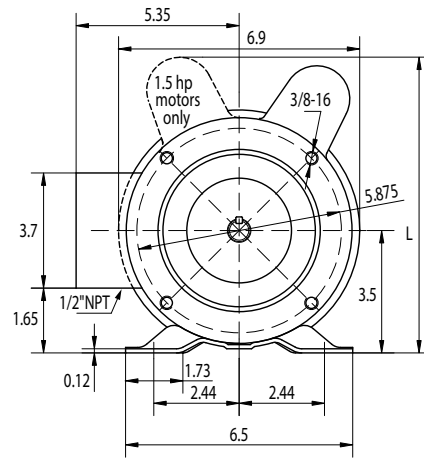

L = 8.19"; all except 1.5 hp motors
 L = 8.5"; 1.5 hp motors

MTR 56C-FRAME THREE-PHASE ROLLED-STEEL MOTOR DIMENSIONS

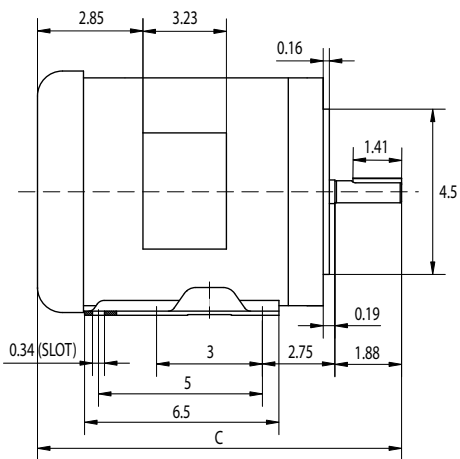

C = 12.2"; 0.33 to 1hp motors
 C = 12.6"; 1.5hp MTR-1P5-3BD18
 C = 12.2"; 1.5hp MTR-1P5-3BD36
 C = 13.8"; 2hp MTR-002-3BD18
 C = 12.4"; 2hp MTR-002-3BD36

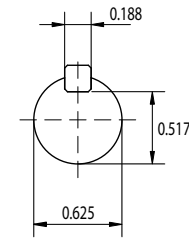

MTR-xxx-3BDxx IronHorse Motors
 (3-phase rolled steel)

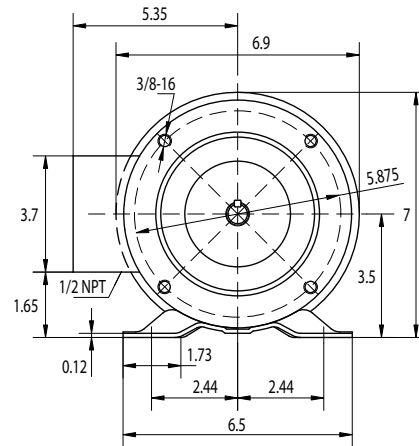

MTR JUNCTION BOX DIMENSIONS

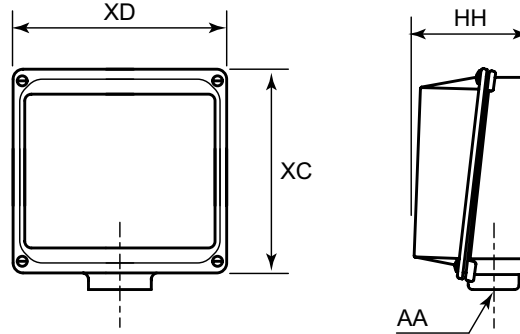

Junction Box Dimensions (in)				
Frame Size	XD (Width)	XC (Height)	HH (Depth)	AA (Conduit Hole) (NPT)
56(H) C	3.2	3.7	1.6	1/2

MTR TERMINAL AND WIRING DIAGRAMS

MTR GENERAL-PURPOSE MOTORS

1/3 hp – 1.5hp 1Ø MTR models
6-Lead, 115/208-230 VAC

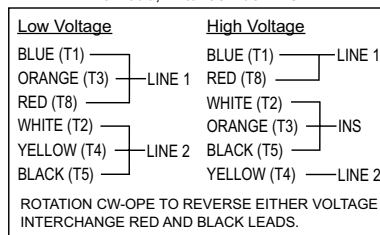

MTR MOTORS DECIBEL LEVELS

The decibel (sound) level of an IronHorse® motor should be measured after initial startup, after 30 days, and after six months of use. Decibel levels should remain fairly consistent and can be an indication of misalignment and premature bearing wear. If the measured decibel level for your IronHorse model exceeds the value listed below by more than 10%, contact AutomationDirect or a local motor service technician found at www.easa.com.

MTR Average T-Frame Decibel Levels					
Noise Level: Lw dB(A) @ 1m					
Frame Size	HP	1800 RPM		3600 RPM	
		1Ø	3Ø	1Ø	3Ø
56(H)C	1/3	65.0	65.0	-	75.0
	1/2				
	3/4				
	1				
	1-1/2	70.0	-	80.0	
	2				
	3	-	-	-	-

SPARE/REPLACEMENT PARTS FOR MTR SINGLE-PHASE MOTORS

MTR Single-Phase Motor Spare/Replacement Parts (NOT for MTR2 Motors)*									
Part Number	Accessory Type	Capacitance (μF)	Rated Voltage	Dimension Height x Ø (in[mm])	Applicable MTR Motor Number	MTR Motor HP ; RPM			
MTA-CAP-01	Start capacitor	200	165	3.15 x 1.65 [80.0 x 41.9]	MTR-P33-1AB18	1/3 ; 1800			
MTA-CAP-02		250			MTR-P50-1AB18	1/2 ; 1800			
MTA-CAP-03		300			MTR-P75-1AB18	3/4 ; 1800			
MTA-CAP-04		250			MTR-001-1AB18	1 ; 1800			
MTA-CAP-08		400			MTR-1P5-1AB18	1-1/2 ; 1800			
MTA-CAP-06		Run capacitor			40	450	4.02 x 1.75 [102.1 x 44.5]	MTR-1P5-1AB18	1-1/2 ; 1800
MTA-CAP-09	35		4.0 x 1.8 [101 x 45]	MTR-1P5-1AB36	1-1/2 ; 3600				
MTA-CSW-01	Centrifugal switch		N/A	N/A	N/A	MTR-xxx-1AB18	all 1800 rpm		
MTA-CSW-02		MTR-1P5-1AB36				3600 rpm			
MTAR-BASE-56	Motor base	N/A				N/A	N/A	MTR-xxx-1ABxx	All
MTAR-FAN-56	Fan								
MTAR-JBOX-56	Junction box								
MTAR-SHROUD-56	Fan shroud								

* These accessories are spare/replacement components only for MTR series IronHorse motors. Accessories for MTR series motors are NOT compatible with MTR2 series motors.

MTR Series Three-Phase Motor Spare/Replacement Parts*			
Part Number	Description	Applicable MTR Motor Number	MTR Motor HP : RPM
MTAR-BASE-56	Motor base	MTR-xxx-xBDxx	All
MTAR-FAN-56	Fan		
MTAR-JBOX-56	Junction box		
MTAR-SHROUD-56	Fan shroud		

* These accessories are spare/replacement components only for MTR series IronHorse motors.

MTR BEARING SIZE INFORMATION

All IronHorse® cast-iron motors use premium name-brand bearings (NSK, NTN, or SKF). Below is a bearing size chart listing the type of bearings used in each frame size of IronHorse MTR motors. The bearing types are also listed on the motor nameplate.

MTR Bearing Size Chart		
Frame Size	Drive End Bearing	Opposite Drive End Bearing
56(H)C	6203-ZZ or 6205	6203-ZZ

MTSS SERIES MOTORS

MTSS FEATURES AND SPECIFICATIONS

Stainless-Steel 56C-Frame
Three-Phase Motor with
Round Body



Stainless-Steel 56C-Frame
Three-Phase Motor with
Rigid Base



IronHorse stainless steel 56C-frame three-phase motors are available from 1/3 hp to 2 hp. All models have TEFC frames and stainless steel end bells, and they are available with or without rigid mounting bases.

MTSS STAINLESS-STEEL 56C-FRAME 3-PHASE MOTOR SPECIFICATIONS – 1800 & 3600 RPM

Motor Specifications – MTSS 3-Phase 56C-Frame Motors – 1800 & 3600 rpm													
Part Number	HP	Base RPM	Voltage	Service Factor	NEMA Design	NEMA Frame	Housing	F.L. Amps @ 208-230V/460V	Approx Weight (lb)				
1800 RPM			208-230/460 – 3-phase	1.15	B	56C flange mount	TEFC stainless steel frame with round body	1800 RPM					
MTSS-P33-3BD18R	1/3	1800						1.5-1.4 / 0.7	27				
MTSS-P50-3BD18R	1/2							1.55-1.5 / 0.75	27				
MTSS-P75-3BD18R	3/4							2.6-2.4 / 1.2	29				
MTSS-001-3BD18R	1							3.5-3.2 / 1.6	34				
MTSS-1P5-3BD18R	1-1/2							4.6-4.2 / 2.1	36				
MTSS-002-3BD18R	2						6.6-6.0 / 3.0	43					
		3600					208-230/460 – 3-phase	1.15	B	56C flange mount	F1 conduit box location	1800 RPM	
MTSS-P33-3BD18	1/3											1.5-1.4 / 0.7	28
MTSS-P50-3BD18	1/2											1.55-1.5 / 0.75	28
MTSS-P75-3BD18	3/4											2.6-2.4 / 1.2	30
MTSS-001-3BD18	1										3.5-3.2 / 1.6	35	
MTSS-1P5-3BD18	1-1/2										4.6-4.2 / 2.1	36	
MTSS-002-3BD18	2										6.6-6.0 / 3.0	44	
			3600	208-230/460 – 3-phase	1.15	B					56C flange mount	TEFC stainless steel frame with rigid base	3600 RPM
MTSS-P50-3BD36	1/2	1.99-1.8 / 0.9					29						
MTSS-P75-3BD36	3/4	2.4-2.3 / 1.15					31						
MTSS-001-3BD36	1	3.3-3.0 / 1.5					31						
MTSS-1P5-3BD36	1-1/2	4.2-4.0 / 2.0					36						
MTSS-002-3BD36	2	5.0-4.8 / 2.4					43						

Note: Please review the AutomationDirect Terms & Conditions for warranty and service on this product.

MTSS STAINLESS-STEEL 56C-FRAME 3-PHASE MOTORS FEATURES & SPECS (CONTINUED)

MTSS MOTOR PERFORMANCE DATA – 1800 RPM

Performance Data
MTSS Three-Phase 56C-Frame Motors – 1800 rpm
 (460V data except as indicated)

Part Number	F.L. RPM	Minimum Speed (rpm)		Maximum Speed (rpm)		Current @ 460V (Amps)	
		CT (2:1)	VT (5:1)	CHP*	Safe	No Load	Locked Rotor
MTSS-P33-3BD18(R)	1725	900	360	2250	4500	0.29	4.2
MTSS-P50-3BD18(R)	1725					0.30	4.6
MTSS-P75-3BD18(R)	1725					0.44	7.3
MTSS-001-3BD18(R)	1740					0.61	10.0
MTSS-1P5-3BD18(R)	1740					0.70	13.8
MTSS-002-3BD18(R)	1740					1.08	21.0

* Maximum Constant HP rpm is for direct-coupled loads.

Part Number	HP	Torque (lb-ft)			F.L. Efficiency (%)	F.L. Power Factor	Rotor Inertia (lb-ft ²)
		Full Load	Locked Rotor	Break-down			
MTSS-P33-3BD18(R)	1/3	1.0	2.9	3.9	82.5	0.71	0.078
MTSS-P50-3BD18(R)	1/2	1.5	3.8	5.2	82.5	0.76	0.078
MTSS-P75-3BD18(R)	3/4	2.2	5.0	7.0	82.5	0.78	0.081
MTSS-001-3BD18(R)	1	3.0	7.2	9.9	84.0	0.78	0.090
MTSS-1P5-3BD18(R)	1-1/2	4.4	10.3	14.5	84.0	0.83	0.087
MTSS-002-3BD18(R)	2	5.9	13.9	18.9	84.0	0.83	0.101

MTSS MOTOR PERFORMANCE DATA – 3600 RPM

Performance Data
MTSS Three-Phase 56C-Frame Motors – 3600 rpm
 (460V data except as indicated)

Part Number	F.L. RPM	Minimum Speed (rpm)		Maximum Speed (rpm)		Current @ 460V (Amps)	
		CT (2:1)	VT (5:1)	CHP*	Safe	No Load	Locked Rotor
MTSS-P50-3BD36	3460	1800	720	4500	4500	0.36	6.0
MTSS-P75-3BD36	3470					0.43	7.6
MTSS-001-3BD36	3470					0.58	10.0
MTSS-1P5-3BD36	3480					0.70	15.0
MTSS-002-3BD36	3480					0.85	18.0

* Maximum Constant HP rpm is for direct-coupled loads.

Part Number	HP	Torque (lb-ft)			F.L. Efficiency (%)	F.L. Power Factor	Rotor Inertia (lb-ft ²)
		Full Load	Locked Rotor	Break-down			
MTSS-P50-3BD36	1/2	0.7	1.9	2.5	77.0	0.88	0.077
MTSS-P75-3BD36	3/4	1.1	2.7	3.3	73.0	0.84	0.100
MTSS-001-3BD36	1	1.5	4.6	5.5	80.0	0.72	0.094
MTSS-1P5-3BD36	1-1/2	2.3	6.6	9.0	84.0	0.74	0.098
MTSS-002-3BD36	2	2.9	8.6	11.3	80.0	0.72	0.107

MTSS MOTOR DIMENSIONS

(DIMENSIONS = INCHES)

MTSS 56C-FRAME THREE-PHASE ROUND-BODY MOTOR DIMENSIONS

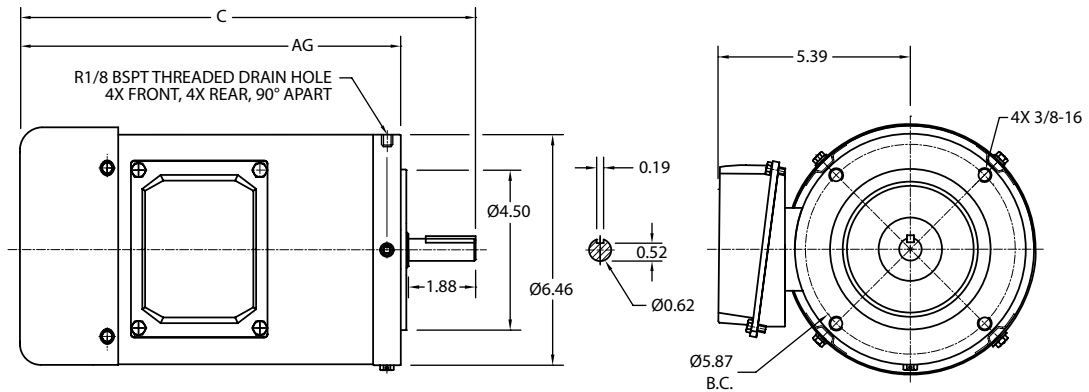

AC MOTOR WITHOUT FEET		
PART NUMBER	DIM. C	DIM. AG
MTSS-P33-3BD18R	11.59	9.50
MTSS-P50-3BD18R	11.59	9.50
MTSS-P75-3BD18R	12.76	10.67
MTSS-001-3BD18R	12.76	10.67
MTSS-1P5-3BD18R	12.76	10.67
MTSS-002-3BD18R	12.76	10.48

MTSS 56C-FRAME THREE-PHASE RIGID-BASE MOTOR DIMENSIONS

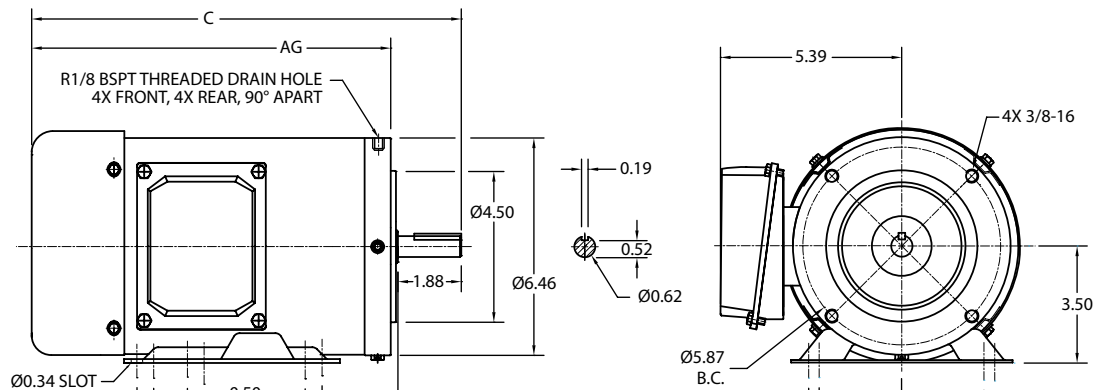

AC MOTOR WITH FEET			
PART NUMBER	DIM. C	DIM. AG	DIM. F3
MTSS-P33-3BD18	11.77	9.69	n/a
MTSS-P50-3BDxx	11.77	9.69	n/a
MTSS-P75-3BDxx	12.76	10.67	5.00
MTSS-001-3BDxx	12.76	10.67	5.00
MTSS-1P5-3BDxx	12.76	10.67	5.00
MTSS-002-3BDxx	13.50	11.42	5.00

MTSS JUNCTION BOX DIMENSIONS

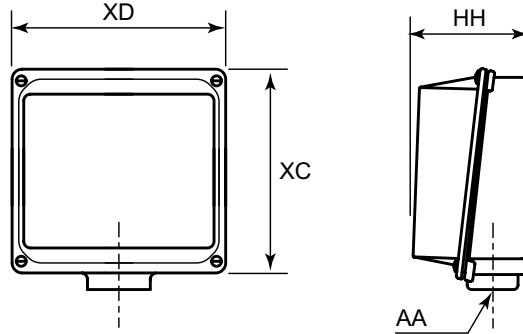

Junction Box Dimensions (in)				
Frame Size *	XD (Width)	XC (Height)	HH (Depth)	AA (Conduit Hole) (NPT)
56	3.8	3.3	1.5	0.86*
* MTSS conduit holes are unthreaded through holes with cable glands installed.				

MTSS DECIBEL LEVELS

The decibel (sound) level of an IronHorse® motor should be measured after initial startup, after 30 days, and after six months of use. Decibel levels should remain fairly consistent and can be an indication of misalignment and premature bearing wear. If the measured decibel level for your IronHorse model exceeds the value listed below by more than 10%, contact AutomationDirect or a local motor service technician found at www.easa.com.

MTSS Average T-Frame Decibel Levels		
Frame Size	HP	Noise Level: Lw dB(A) @ 1m
		MTSS
56C	–	65

MTSS MOTOR MOUNTING

MTSS stainless-steel motors can be mounted in any orientation, horizontal or vertical, as long as the drain plugs are installed in the two lower locations.

The motors have four drain holes in the 12:00, 3:00, 6:00, and 9:00 positions of each end of the motor. The motors are shipped with two drain plugs installed in the front and rear 6:00 positions of the end bells, and drain-hole seal plugs installed in the other positions. This is the standard arrangement for the most ‘normal’ horizontal mounting orientation for a rigid-base motor.

When the motors are mounted in other orientations, switch drain plugs and seals so that there are two drain plugs on opposite sides of the bottom surface of the motor. For example, in a shaft-downward mounting orientation, install both drain plugs 180° apart in the front end bell. (Remove the fan shroud for access to the rear drain plugs and seals.)

Motor shown with fan cover removed

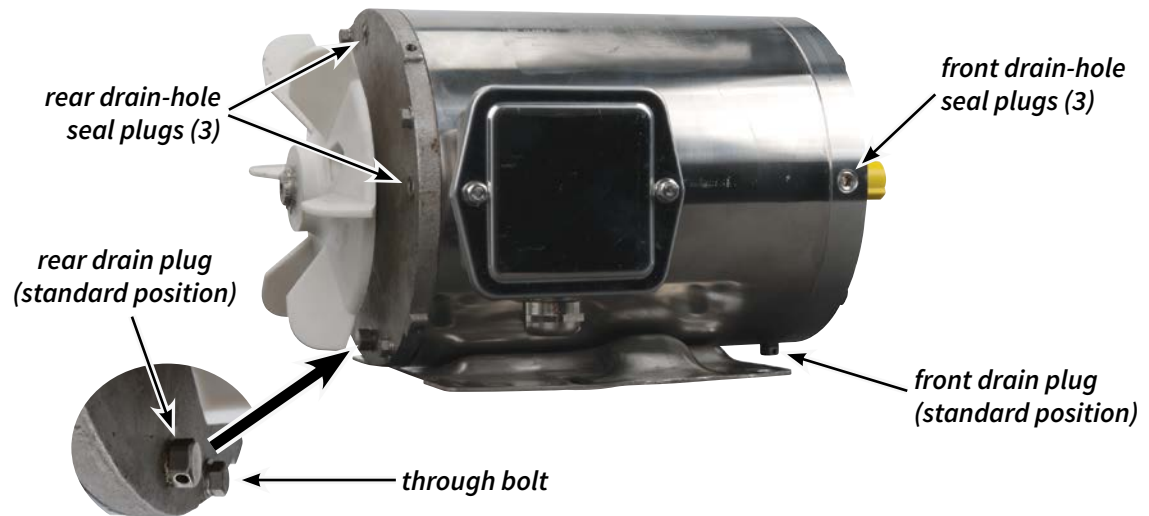

Some IronHorse motors include a shaft slinger (rubber washer) on the output shaft at the end bell. The shaft slinger provides an added layer of protection to the output shaft seal. We recommend leaving the slinger in place, but it can be removed if it poses an interference problem with C-Face-mounted gearboxes.

SPARE/REPLACEMENT PARTS FOR MTSS STAINLESS-STEEL THREE-PHASE MOTORS

MTSS Stainless-Steel Three-Phase Motor Replacement Parts		
Part Number	Description	Picture
MTAS-CG-M22	Cable gland; M22 x 1.5 mm thread; (1) silicone rubber gasket accommodates a cable diameter range of 0.393 to 0.512 in (10 to 13 mm); IP66 protection level; nickel-plated brass housing. This is a SPARE part for IronHorse MTSS motors – one cable gland is pre-installed on each MTSS motor.	

MTSS BEARING SIZE INFORMATION

All IronHorse® cast-iron motors use premium name-brand bearings (NSK, NTN, or SKF). Below is a bearing size chart listing the type of bearings used in each frame size of IronHorse MTSS motors. The bearing types are also listed on the motor nameplate.

MTSS Bearing Size Chart		
Frame Size	Drive End Bearing	Opposite Drive End Bearing
56C	6203-ZZ or 6205	6205

MTC EPACT SERIES MOTORS

MTC FEATURES AND SPECIFICATIONS

EPAct Cast-Iron T-Frame

EPAct Cast-Iron TC-Frame



IronHorse 1800 rpm T-frame cast-iron industrial duty EPAct motors are available from 1–300 hp, and TC-frame motors are available from 1–100 hp. Optional C-face kits are available for IronHorse T-frame EPAct motors. (EPAct C-face kits are NOT compatible with Premium Efficiency motors.) All models have a TEFC frame and full length mounting feet.

MTC MOTOR SPECIFICATIONS – CAST-IRON T-FRAME AND TC-FRAME – 1800 RPM

Motor Specifications – EPAct T & TC ⁽¹⁾ Frame Three-Phase Motors – 1800 rpm										
Part Number	HP ⁽³⁾	NEMA Frame	Voltage	Housing	Shaft Material	Conduit Box Location (2)	Holes / Foot	Service Factor	F.L. Amps @ 230V/460V	Product Weight (lb)
MTC-001-3BD18	1	143T	208-230/460 – 3-phase	TEFC cast iron	1045 CS	F1(F2)	2	1.15	3.0 / 1.5	58
MTC-001-3BD18CK (1)		143TC								61
MTC-1P5-3BD18	1-1/2	145T					3		4.2 / 2.1	60
MTC-1P5-3BD18CK (1)		145TC								67
MTC-002-3BD18	2	145T					3		5.4 / 2.7	70
MTC-002-3BD18CK (1)		145TC								69
MTC-003-3BD18	3	182T					2		7.72 / 3.86	90
MTC-003-3BD18CK (1)		182TC								112
MTC-005-3BD18	5	184T					3		11.8 / 5.9	110
MTC-005-3BD18CK (1)		184TC								125
MTC-7P5-3BD18	7-1/2	213T					2		18.6 / 9.3	160
MTC-7P5-3BD18CK (1)		213TC								170

1) TC-frame motors are T-frame motors with applicable C-face accessory kits installed.
 2) F1(F2) indicates F1 conduit box mounting location, field convertible to F2. (Refer to "Chapter 5: Reference" for further information regarding F1 and F2 mounting.)
 3) For warranty on motors 50 hp and above, motors must be inspected by an EASA motor repair or service center. See AutomationDirect Terms & Conditions for details.

*** TABLE CONTINUED ON NEXT PAGE ***

MTC EPACK CAST-IRON 3-PHASE MOTORS FEATURES AND SPECS (CONTINUED)

MTC MOTOR SPECIFICATIONS – CAST-IRON T-FRAME AND TC-FRAME – 1800 RPM

***** Table Continued From Previous Page (for 1–7.5hp motors) *****

Motor Specifications – EPACK T & TC ⁽¹⁾ Frame Three-Phase Motors – 1800 rpm													
Part Number	HP ⁽³⁾	NEMA Frame	Voltage	Housing	Shaft Material	Conduit Box Location ⁽²⁾	Holes / Foot	Service Factor	F.L. Amps @ 230V/460V	Product Weight (lb)			
MTC-010-3BD18	10	215T	208-230/460 – 3-phase	TEFC cast iron	1045 CS	F1(F2)	3	1.15	24.8 / 12.4	179			
MTC-010-3BD18CK (1)		215TC								198			
MTC-015-3BD18	15	254T							254TC	F1(F2)	2	35.4 / 17.7	290
MTC-015-3BD18CK (1)		310											
MTC-020-3BD18	20	256T							256TC	F1(F2)	3	47.6 / 23.8	326
MTC-020-3BD18CK (1)		360											
MTC-025-3BD18	25	284T							284TC	F1	2	56.4 / 28.2	400
MTC-025-3BD18CK (1)		440											
MTC-030-3BD18	30	286T							286TC	F1	3	67.2 / 33.6	451
MTC-030-3BD18CK (1)		470											
MTC-040-3BD18	40	324T							324TC	F1	2	93.0 / 46.5	589
MTC-040-3BD18CK (1)		608											
MTC-050-3BD18 (3)	50	326T							326TC	F1	3	114.6 / 57.3	640
MTC-050-3BD18CK (1)(3)		652											
MTC-060-3BD18 (3)	60	364T							364TC	F1	2	139.4 / 69.7	780
MTC-060-3BD18CK (1)(3)		780											
MTC-075-3BD18 (3)	75	365T							365TC	F1	3	172.8 / 86.4	870
MTC-075-3BD18CK (1)(3)		837											
MTC-100-3BD18 (3)	100	405T	405TC	F1	3	230 / 115	1350						
MTC-100-3BD18CK (1)(3)		1335											
MTC-125-3BD18 (3)	125	444T			F1(F2)	2	274 / 137	1500					
MTC-150-3BD18 (3)	150	445T			F1(F2)	3	326 / 163	1630					
MTC-200-3BD18 (3)	200	445/7T			F1(F2)	3	446 / 223	1858					
MTC-250-3D18 (3)	250	449T	460		4140 CS	F1	2	– / 282	2508				
MTC-300-3D18 (3)	300	449T						– / 334	2728				

1) TC-frame motors are T-frame motors with applicable C-face accessory kits installed.
 2) F1(F2) indicates F1 conduit box mounting location, field convertible to F2.
 (Refer to "Chapter 5: Reference" for further information regarding F1 and F2 mounting.)
 3) For warranty on motors 50 hp and above, motors must be inspected by an EASA motor repair or service center. See AutomationDirect Terms & Conditions for details.

MTC EPACT CAST-IRON 3-PHASE MOTORS FEATURES AND SPECS (CONTINUED)

MTC MOTOR SPECIFICATIONS – CAST-IRON T-FRAME – 1200 & 3600 RPM

Motor Specifications – EPAct T-Frame Three-Phase Motors – 1200 & 3600 rpm										
Part Number	HP (3)	NEMA Frame	Voltage	Housing	Shaft Material	Conduit Box Location (2)	Holes / Foot	Service Factor	F.L. Amps @ 230V/460V	Product Weight (lb)
1200 rpm Base Speed										
MTC-001-3BD12	1	145T	208-230/460 3-phase	TEFC cast iron	1045 carbon steel	F1(F2)	4	1.15	3.2 / 1.6	62
MTC-1P5-3BD12	1-1/2	182T					2		4.8 / 2.4	106
MTC-002-3BD12	2	184T					4		6.1 / 3.1	119
MTC-003-3BD12	3	213T					2		8.4 / 4.2	171
MTC-005-3BD12	5	215T					4		13.6 / 6.8	189
MTC-7P5-3BD12	7-1/2	254T					2		21.2 / 10.6	272
MTC-010-3BD12	10	256T					4		28.0 / 14.0	307
3600 rpm Base Speed										
MTC-1P5-3BD36	1-1/2	143T	208-230/460 3-phase	TEFC cast iron	1045 carbon steel	F1(F2)	2	1.15	3.8 / 1.9	62
MTC-002-3BD36	2	145T					4		5.0 / 2.5	66
MTC-003-3BD36	3	182T					2		7.2 / 3.6	107
MTC-005-3BD36	5	184T					4		11.3 / 5.7	112
MTC-7P5-3BD36	7-1/2	213T					2		16.8 / 8.4	165
MTC-010-3BD36	10	215T					4		22.4 / 11.2	185
<p>2) F1(F2) indicates F1 conduit box mounting location, field convertible to F2. (Refer to "Chapter 5: Reference" for further information regarding F1 and F2 mounting.)</p> <p>3) For warranty on motors 50 hp and above, motors must be inspected by an EASA motor repair or service center. See AutomationDirect Terms & Conditions for details.</p>										

MTC EPACT CAST-IRON 3-PHASE MOTORS FEATURES AND SPECS (CONTINUED)

MTC MOTOR PERFORMANCE DATA – CAST-IRON T-FRAME AND TC-FRAME – 1800 RPM

Performance Data – EPACT T & TC(1) Frame Three-Phase Motors – 1800 rpm (460 Volt except as indicated)											
Part Number	HP	NEMA Design	F.L. RPM	Minimum Speed (rpm)		Maximum Speed (rpm)		F.L. Efficiency (%)	F.L. Power Factor	Rotor Inertia (lb-ft ²)	
				CT (2:1)	VT (5:1)	CHP(2)	Safe				
<i>MTC-001-3BD18(CK)</i>	1	B	1760	900	360	2700	5400	82.5	0.71	0.068	
<i>MTC-1P5-3BD18(CK)</i>	1-1/2		1755				5400	84.0	0.74	0.083	
<i>MTC-002-3BD18(CK)</i>	2		1750				5400	84.0	0.77	0.09	
<i>MTC-003-3BD18(CK)</i>	3		1750				5400	87.5	0.81	0.22	
<i>MTC-005-3BD18(CK)</i>	5		1750				5400	87.5	0.84	0.285	
<i>MTC-7P5-3BD18(CK)</i>	7-1/2		1760				5400	89.5	0.81	0.602	
<i>MTC-010-3BD18(CK)</i>	10		A				1760	4200	89.5	0.83	0.742
<i>MTC-015-3BD18(CK)</i>	15	1770					4200	91.0	0.83	1.71	
<i>MTC-020-3BD18(CK)</i>	20	1770					4200	91.0	0.84	2.18	
<i>MTC-025-3BD18(CK)</i>	25	1775					4200	92.4	0.87	3.3	
<i>MTC-030-3BD18(CK)</i>	30	1775					4200	92.4	0.86	3.76	
<i>MTC-040-3BD18(CK)</i>	40	1775					3600	93.0	0.86	5.84	
<i>MTC-050-3BD18(CK)</i>	50	1775					3600	93.0	0.86	6.34	
<i>MTC-060-3BD18(CK)</i>	60	B					1785	3600	93.6	0.85	11.4
<i>MTC-075-3BD18(CK)</i>	75						1785	3600	94.1	0.84	12.7
<i>MTC-100-3BD18(CK)</i>	100						1785	2800	94.5	0.87	28.5
<i>MTC-125-3BD18</i>	125						1785	2800	94.5	0.86	38.9
<i>MTC-150-3BD18</i>	150						1785	2800	95.0	0.87	47.2
<i>MTC-200-3BD18</i>	200						1785	2800	95.0	0.87	62.3
<i>MTC-250-3D18</i>	250						1790	2800	95.9	0.87	86.0
<i>MTC-300-3D18</i>	300		1790				2800	95.7	0.88	105.0	

1) TC-frame motors (MTC-xxx-xxxxCK) are T-frame motors with applicable C-face accessory kits installed.
 2) Maximum Constant HP RPM is for direct-coupled loads.

*** TABLE CONTINUED NEXT PAGE ***

MTC EPACK CAST-IRON 3-PHASE MOTORS FEATURES AND SPECS (CONTINUED)

MTC MOTOR PERFORMANCE DATA – CAST-IRON T-FRAME AND TC-FRAME – 1800 RPM

***** Table Continued From Previous Page *****							
Performance Data – EPACK T & TC ⁽¹⁾ Frame 3-Phase Motors – 1800 rpm (460 Volt except as indicated)							
Part Number	HP	Current @ 230V/460V (Amps)			Torque (lb-ft)		
		No Load	Full Load	Locked Rotor	Full Load	Locked Rotor	Break-down
MTC-001-3BD18(CK)	1	1.9 / 0.95	3.0 / 1.5	30.0 / 15.0	3.00	7.50	10.50
MTC-1P5-3BD18(CK)	1-1/2	2.44 / 1.22	4.2 / 2.1	40.0 / 20.0	4.41	10.58	14.11
MTC-002-3BD18(CK)	2	2.76 / 1.38	5.4 / 2.7	50.0 / 25.0	6.05	13.92	17.55
MTC-003-3BD18(CK)	3	3.74 / 1.87	7.72 / 3.86	64.0 / 32.0	9.07	25.40	29.93
MTC-005-3BD18(CK)	5	5.1 / 2.55	11.8 / 5.9	92.0 / 46.0	15.1	40.8	46.8
MTC-7P5-3BD18(CK)	7-1/2	8.98 / 4.49	18.6 / 9.3	127 / 63.5	22.0	44.0	72.6
MTC-010-3BD18(CK)	10	13.0 / 6.5	24.8 / 12.4	200 / 100	29.8	59.6	92.4
MTC-015-3BD18(CK)	15	15.6 / 7.8	35.4 / 17.7	280 / 140	44.5	89.0	124.6
MTC-020-3BD18(CK)	20	19.0 / 9.5	47.6 / 23.8	400 / 200	59.7	119.4	155.2
MTC-025-3BD18(CK)	25	24.0 / 12.0	56.4 / 28.2	440 / 220	73.9	152.2	206.9
MTC-030-3BD18(CK)	30	27.0 / 13.5	67.2 / 33.6	520 / 260	88.7	177.4	257.2
MTC-040-3BD18(CK)	40	35.0 / 17.5	93.0 / 46.5	720 / 360	118	248	355
MTC-050-3BD18(CK)	50	38.6 / 19.3	114.6 / 57.3	880 / 440	148	311	444
MTC-060-3BD18(CK)	60	48.0 / 24.0	139.4 / 69.7	870 / 435	179	322	483
MTC-075-3BD18(CK)	75	59.2 / 29.6	172.8 / 86.4	1086 / 543	221	398	530
MTC-100-3BD18(CK)	100	72.0 / 36.0	230 / 115	1450 / 725	296	592	858
MTC-125-3BD18	125	82.0 / 41.0	274 / 137	1815 / 908	355	604	888
MTC-150-3BD18	150	97.6 / 48.8	326 / 163	2170 / 1085	433	779	1083
MTC-200-3BD18	200	140 / 70.0	446 / 223	2900 / 1450	590	1180	1652
MTC-250-3D18	250	- / 85.6	- / 282	- / 2017	728	1660	2402
MTC-300-3D18	300	- / 96.6	- / 334	- / 2351	864	1953	2817

1) TC-frame motors (MTC-xxx-xxxxCK) are T-frame motors with applicable C-face accessory kits installed.

*** TABLE CONTINUED NEXT PAGE ***

MTC EPACK CAST-IRON 3-PHASE MOTORS FEATURES AND SPECS (CONTINUED)

MTC MOTOR PERFORMANCE DATA – CAST-IRON T-FRAME AND TC-FRAME – 1800 RPM

*** TABLE CONTINUED FROM PREVIOUS PAGE ***				
Performance Data EPAct T & TC(1) Frame Three-Phase Motors 1800 rpm – (460 Volt except as indicated)				
Part Number	HP	Slip (%)	Max Time @ Locked Rotor Current (hot)	Temperature Rise @ Full Load
MTC-001-3BD18(CK)	1	2.22	20 seconds	80° C (176°F)
MTC-1P5-3BD18(CK)	1-1/2	2.50		
MTC-002-3BD18(CK)	2	2.78		
MTC-003-3BD18(CK)	3	2.78		
MTC-005-3BD18(CK)	5	2.78		
MTC-7P5-3BD18(CK)	7-1/2	2.22		
MTC-010-3BD18(CK)	10	2.20	13 seconds	
MTC-015-3BD18(CK)	15	1.67	20 seconds	
MTC-020-3BD18(CK)	20	1.67		
MTC-025-3BD18(CK)	25	1.38	16 seconds	
MTC-030-3BD18(CK)	30	1.38	20 seconds	
MTC-040-3BD18(CK)	40	1.39		
MTC-050-3BD18(CK)	50	1.39		
MTC-060-3BD18(CK)	60	0.83		
MTC-075-3BD18(CK)	75	0.83		
MTC-100-3BD18(CK)	100	0.83		
MTC-125-3BD18	125	0.83	15 seconds	
MTC-150-3BD18	150	0.83		
MTC-200-3BD18	200	0.83		
MTC-250-3D18	250	0.54	20 seconds	85° C (185°F)
MTC-300-3D18	300	0.53		

1) TC-frame motors (MTC-xxx-xxxxCK) are T-frame motors with applicable C-face accessory kits installed.

MTC EPACK CAST-IRON 3-PHASE MOTORS FEATURES AND SPECS (CONTINUED)

MTC MOTOR PERFORMANCE DATA – CAST-IRON T-FRAME – 1200 RPM

Performance Data – EPACK T-Frame Three-Phase Motors – 1200 rpm (460 Volt except as indicated)							
Part Number	HP	NEMA Design	F.L. RPM	Minimum Speed (rpm)		Maximum Speed (rpm)	
				Constant Torque (2:1)	Variable Torque (5:1)	CHP(2)	Safe
MTC-001-3BD12	1	B	1150	600	240	1800	3600
MTC-1P5-3BD12	1-1/2		1170				
MTC-002-3BD12	2		1180				
MTC-003-3BD12	3						
MTC-005-3BD12	5						
MTC-7P5-3BD12	7-1/2						
MTC-010-3BD12	10	A					
Part Number	HP	Current @ 230V/460V (Amps)			Torque (lb-ft)		
		No Load	Full Load	Locked Rotor	Full Load	Locked Rotor	Break-down
MTC-001-3BD12	1	3.2 / 1.6	3.2 / 1.6	25.0 / 12.5	4.59	11.48	14.69
MTC-1P5-3BD12	1-1/2	3.5 / 1.8	4.8 / 2.4	40.0 / 20.0	6.60	18.5	24.4
MTC-002-3BD12	2	4.0 / 2.0	6.1 / 3.1	50.0 / 25.0	9.02	24.4	30.7
MTC-003-3BD12	3	4.7 / 2.4	8.4 / 4.2	64.0 / 32.0	13.4	22.8	37.5
MTC-005-3BD12	5	7.3 / 3.7	13.6 / 6.8	92.0 / 46.0	22.2	37.7	53.3
MTC-7P5-3BD12	7-1/2	12.6 / 6.3	21.2 / 10.6	127 / 63.5	32.9	75.7	98.7
MTC-010-3BD12	10	7.6 / 3.8	28.0 / 14.0	168 / 84.0	44.8	98.6	139
Part Number	HP	Temperature Rise @ Full Load	Max Time Locked Rotor (Hot)	F.L. Efficiency (%)	F.L. Power Factor	Rotor Inertia (lb-ft ²)	Slip (%)
MTC-001-3BD12	1	80°C (176°F)	20 seconds	81.1	0.72	0.009	3.3
MTC-1P5-3BD12	1-1/2			85.5	0.65	0.068	2.5
MTC-002-3BD12	2			86.5	0.70	0.100	2.5
MTC-003-3BD12	3			87.5	0.72	0.207	1.7
MTC-005-3BD12	5			87.5	0.72	0.258	1.7
MTC-7P5-3BD12	7-1/2			89.5	0.71	0.480	1.7
MTC-010-3BD12	10			89.5	0.74	2.487	1.7

2) Maximum Constant HP RPM is for direct-coupled loads

MTC EPACK CAST-IRON 3-PHASE MOTORS FEATURES AND SPECS (CONTINUED)

MTC MOTOR PERFORMANCE DATA – CAST-IRON T-FRAME – 3600 RPM

Performance Data – EPACK T-Frame Three-Phase Motors – 3600 rpm (460 Volt except as indicated)							
Part Number	HP	NEMA Design	F.L. RPM	Minimum Speed (rpm)		Maximum Speed (rpm)	
				Constant Torque (2:1)	Variable Torque (5:1)	CHP(2)	Safe
MTC-1P5-3BD36	1-1/2	B	3480	1800	720	5400	5400
MTC-002-3BD36	2						
MTC-003-3BD36	3		3520				
MTC-005-3BD36	5		3510				
MTC-7P5-3BD36	7-1/2		3520				
MTC-010-3BD36	10		3530				
Part Number	HP	Current @ 230V/460V (Amps)			Torque (lb-ft)		
		No Load	Full Load	Locked Rotor	Full Load	Locked Rotor	Break-down
MTC-1P5-3BD36	1-1/2	1.4 / 0.7	3.8 / 1.9	40.0 / 20.0	2.23	4.01	5.58
MTC-002-3BD36	2	1.5 / 0.8	5.0 / 2.5	50.0 / 25.0	3.03	6.06	8.18
MTC-003-3BD36	3	2.8 / 1.4	7.2 / 3.6	64.0 / 32.0	4.50	10.4	16.2
MTC-005-3BD36	5	4.0 / 2.0	11.3 / 5.7	92.0 / 46.0	7.46	15.7	26.5
MTC-7P5-3BD36	7-1/2	5.0 / 2.5	16.8 / 8.4	127 / 63.5	11.0	22.0	36.3
MTC-010-3BD36	10	5.7 / 2.8	22.4 / 11.2	162 / 81.0	15.0	33.0	49.5
Part Number	HP	Temperature Rise @ Full Load	Max Time Locked Rotor (Hot)	F.L. Efficiency (%)	F.L. Power Factor	Rotor Inertia (lb-ft ²)	Slip (%)
MTC-1P5-3BD36	1-1/2	80°C (176°F)	20 seconds	82.5	0.86	0.009	3.3
MTC-002-3BD36	2			84.0	0.87	0.010	3.3
MTC-003-3BD36	3			85.5	0.86	0.034	2.2
MTC-005-3BD36	5			87.5	0.88	0.040	2.5
MTC-7P5-3BD36	7-1/2			88.5	0.89	0.258	2.2
MTC-010-3BD36	10			89.5	0.89	0.109	1.9

2) Maximum Constant HP RPM is for direct-coupled loads

MTC MOTOR DIMENSIONS

(DIMENSIONS = INCHES)

MTC EPACT T-FRAME THREE-PHASE MOTOR DIMENSIONS

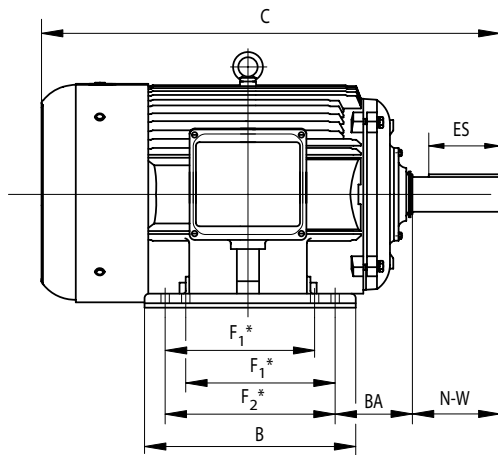

* Various frame sizes have 2 or 4 mounting holes per mounting foot (one mounting foot per side).

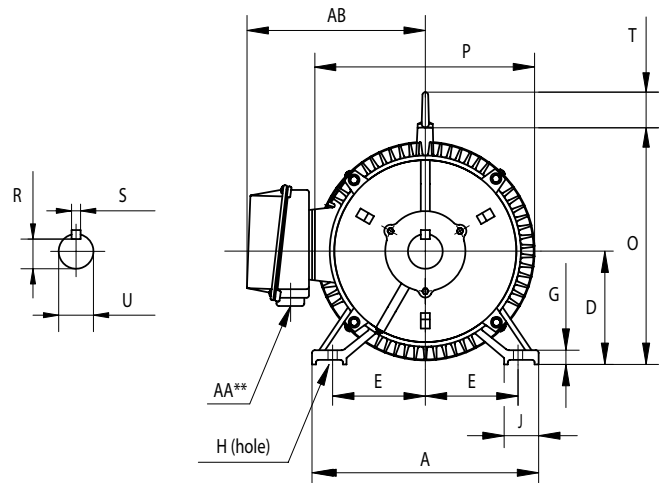

** F1 mounting shown.
** Some frame sizes are F1/F2 convertible.

Dimensions [inches, except as noted]											
EPAct Three-phase T-Frame Motors – 1200, 1800, 3600 rpm											
Part Number	HP	NEMA Frame	A	AA**	AB	B	BA	C	D	E	ES
MTC-001-3BD12	1	145T	7	3/4"npt	6.89	6	2.25	13.58	3.5	2.75	1.41
MTC-001-3BD18		5				12.57					
MTC-1P5-3BD12	1-1/2	182T	9	1" NPT	7.45	6.5	2.75	15.11	4.5	3.75	1.78
MTC-1P5-3BD18		145T	7	3/4"npt	6.89	6	2.25	13.58	3.5	2.75	1.41
MTC-1P5-3BD36		5	12.57								
MTC-002-3BD12	2	184T	9	1" NPT	7.45	7.5	2.75	16.11	4.5	3.75	1.78
MTC-002-3BD18		145T	7	3/4"npt	6.89	6	2.25	13.58	3.5	2.75	1.41
MTC-002-3BD36											
MTC-003-3BD12	3	213T	10.5	1" NPT	8.63	7.5	3.5	18.89	5.25	4.25	2.41
MTC-003-3BD18		182T	9	1" NPT	7.45	6.5	2.75	15.11	4.5	3.75	1.78
MTC-003-3BD36											
MTC-005-3BD12	5	215T	10.5	1" NPT	8.63	9	3.5	20.49	5.25	4.25	2.41
MTC-005-3BD18		184T	9	1" NPT	7.45	7.5	2.75	16.11	4.5	3.75	1.78
MTC-005-3BD36											
MTC-7P5-3BD12	7-1/2	254T	12.5	1.5" NPT	11.2	10.8	4.25	23.29	6.25	5	2.91
MTC-7P5-3BD18		213T	10.5	1" NPT	8.63	7.5	3.5	18.89	5.25	4.25	2.41
MTC-7P5-3BD36											
MTC-010-3BD12	10	256T	12.5	1.5" NPT	11.2	12.5	4.25	25.06	6.25	5	2.91
MTC-010-3BD18		215T	10.5	1" NPT	8.63	9	3.5	20.49	5.25	4.25	2.41
MTC-010-3BD36											

* Various frame sizes have 2 or 4 mounting holes per mounting foot.
** AA dimension is conduit fitting size.
F1 mounting shown; some frame sizes are F1/F2 convertible; refer to T-frame "Motor Specifications" table. (F2 mounting = conduit entrance on right side facing shaft.)
**** TABLE CONTINUED NEXT PAGE (for dimensions F1-U) ****

MTC MOTOR DIMENSIONS (CONTINUED) – (DIMENSIONS = INCHES)

MTC EPACT T-FRAME THREE-PHASE MOTOR DIMENSIONS (CONTINUED)

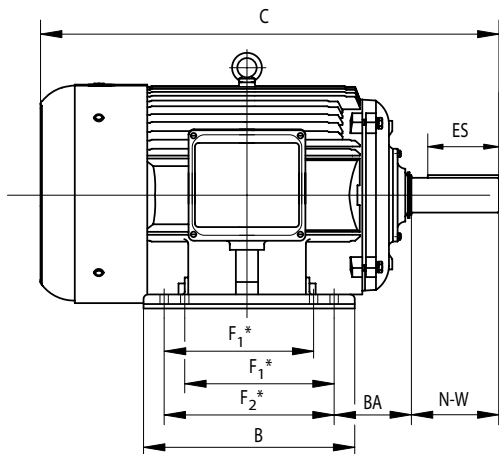

* Various frame sizes have 2 or 4 mounting holes per mounting foot (one mounting foot per side).

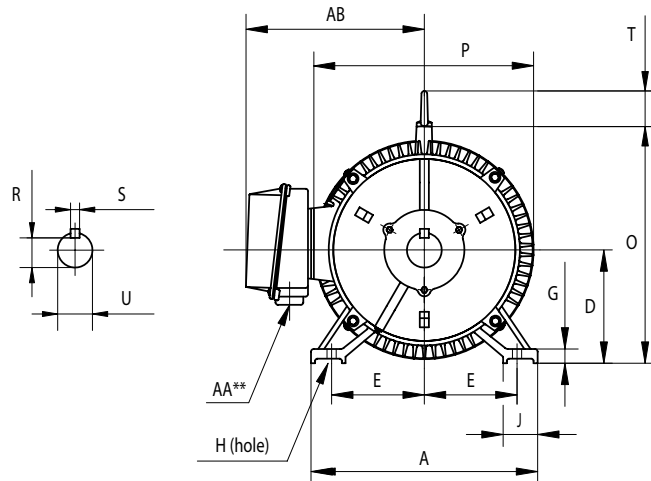

** F1 mounting shown.
** Some frame sizes are F1/F2 convertible.

**** Table Continued Previous Page (for dimensions A–ES) ****

Dimensions [inches, except as noted]

EPACT Three-phase T-Frame Motors – 1200, 1800, 3600 rpm

Part Number	F ₁ *	F ₂ *	G	H	J	N-W	O	P	R	S	T	U
MTC-001-3BD12	4	5	0.512	0.34	1.45	2.25	7.08	7.16	0.771	0.188	0.88	0.875
MTC-001-3BD18	n/a	4									n/a	
MTC-1P5-3BD12	n/a	4.5	0.59	0.41	1.97	2.75	8.97	8.82	0.986	0.25	1.42	1.125
MTC-1P5-3BD18	4	5	0.512	0.34	1.45	2.25	7.08	7.16	0.771	0.188	n/a	0.875
MTC-1P5-3BD36	n/a	4										
MTC-002-3BD12	4.5	5.5	0.59	0.41	1.97	2.75	8.97	8.82	0.986	0.25	1.42	1.125
MTC-002-3BD18	4	5	0.512	0.34	1.45	2.25	7.08	7.16	0.771	0.188	n/a	0.875
MTC-002-3BD36											0.88	
MTC-003-3BD12	n/a	5.5	0.709	0.41	2.36	3.38	10.53	10.4	1.201	0.312	1.73	1.375
MTC-003-3BD18	n/a	4.5	0.59	0.41	1.97	2.75	8.97	8.82	0.986	0.25	1.42	1.125
MTC-003-3BD36												
MTC-005-3BD12	5.5	7	0.709	0.41	2.36	3.38	10.53	10.4	1.201	0.312	1.73	1.375
MTC-005-3BD18	4.5	5.5	0.59	0.41	1.97	2.75	8.97	8.82	0.986	0.25	1.42	1.125
MTC-005-3BD36												
MTC-7P5-3BD12	n/a	8.25	0.787	0.53	2.76	4	12.89	12.6	1.416	0.375	2.05	1.625
MTC-7P5-3BD18	n/a	5.5	0.709	0.41	2.36	3.38	10.53	10.4	1.201	0.312	1.73	1.375
MTC-7P5-3BD36												
MTC-010-3BD12	8.25	10	0.787	0.53	2.76	4	12.89	12.6	1.416	0.375	2.05	1.625
MTC-010-3BD18	5.5	7	0.709	0.41	2.36	3.38	10.53	10.4	1.201	0.312	1.73	1.375
MTC-010-3BD36												

* Various frame sizes have 2 or 4 mounting holes per mounting foot.

** AA dimension is conduit fitting size.

F1 mounting shown; some frame sizes are F1/F2 convertible; refer to T-frame "Motor Specifications" table. (F2 mounting = conduit entrance on right side facing shaft.)

MTC MOTOR DIMENSIONS (CONTINUED) – (DIMENSIONS = INCHES)

MTC EFACT T-FRAME THREE-PHASE MOTOR DIMENSIONS (CONTINUED)

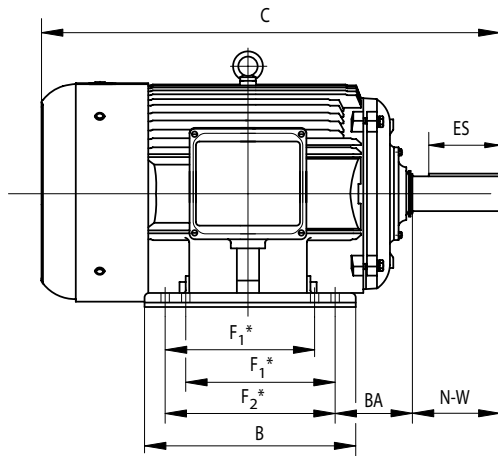

* Various frame sizes have 2 or 4 mounting holes per mounting foot (one mounting foot per side).

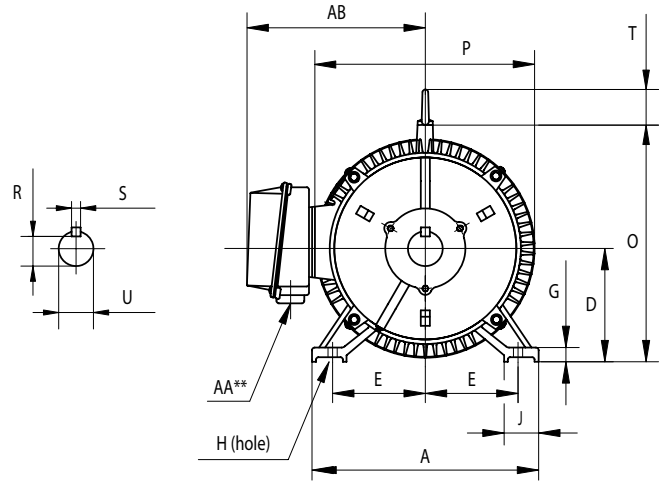

** F1 mounting shown.
** Some frame sizes are F1/F2 convertible.

Dimensions [inches, except as noted]											
EFACT Three-phase T-Frame Motors – 1800 rpm											
Part Number	HP	NEMA Frame	A	AA**	AB	B	BA	C	D	E	ES
MTC-015-3BD18	15	254T	12.5	1.5" NPT	11.2	10.8	4.25	23.29	6.25	5	2.91
MTC-020-3BD18	20	256T				12.5		25.06			
MTC-025-3BD18	25	284T	14	1.5" NPT	12	12.5	4.75	26.64	7	5.5	3.28
MTC-030-3BD18	30	286T				14		28.18			
MTC-040-3BD18	40	324T	16	2" NPT	13.4	14	5.25	29.95	8	6.25	3.91
MTC-050-3BD18	50	326T				15.5		31.24			
MTC-060-3BD18	60	364T	18	3" NPT	15.7	15.2	5.88	32.68	9	7	4.28
MTC-075-3BD18	75	365T				16.2		34.11			
MTC-100-3BD18	100	405T	20	3" NPT	18.31	17.8	6.62	38.35	10	8	5.65
MTC-125-3BD18	125	444T				18.5		42.52			
MTC-150-3BD18	150	445T	22	2x3"NPT	19.41	20.5	7.5	44.5	11	9	6.91
MTC-200-3BD18	200	445/7T				24		48.03			
MTC-250-3D18	250	449T	22	2x3"NPT	19.07	31	7.5	55.51	11	9	7.01
MTC-300-3D18	300										

* Various frame sizes have 2 or 4 mounting holes per mounting foot.
** AA dimension is conduit fitting size.
F1 mounting shown; some frame sizes are F1/F2 convertible; refer to T-frame "Motor Specifications" table. (F2 mounting = conduit entrance on right side facing shaft.)
**** TABLE CONTINUED NEXT PAGE (for dimensions F1-U) ****

MTC MOTOR DIMENSIONS (CONTINUED) – (DIMENSIONS = INCHES)

MTC EPACT T-FRAME THREE-PHASE MOTOR DIMENSIONS (CONTINUED)

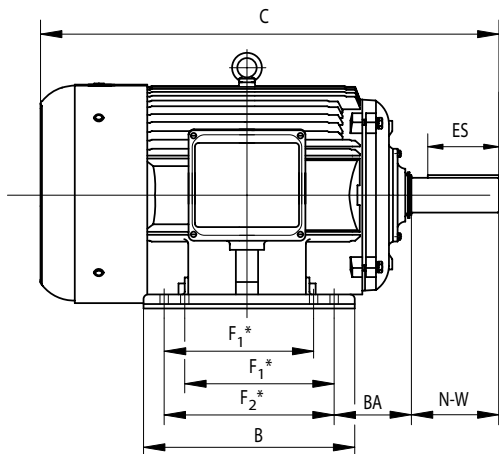

* Various frame sizes have 2 or 4 mounting holes per mounting foot (one mounting foot per side).

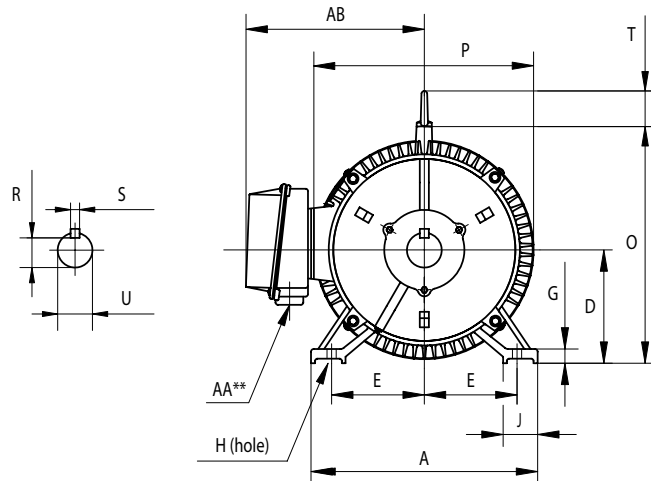

** F1 mounting shown.
** Some frame sizes are F1/F2 convertible.

**** Table Continued Previous Page (for dimensions A–ES) ****

Dimensions [inches, except as noted]

EPAct Three-phase T-Frame Motors – 1800 rpm

Part Number	F ₁ *	F ₂ *	G	H	J	N-W	O	P	R	S	T	U
MTC-015-3BD18	n/a	8.25	0.787	0.53	2.76	4	12.89	12.6	1.416	0.375	2.05	1.625
MTC-020-3BD18	8.25	10										
MTC-025-3BD18	n/a	9.5	0.866	0.53	2.76	4.62	14.28	14.17	1.591	0.5	2.05	1.875
MTC-030-3BD18	9.5	11										
MTC-040-3BD18	n/a	10.5	0.984	0.66	2.76	5.25	15.91	15.75	1.845	0.5	2.44	2.125
MTC-050-3BD18	10.5	12										
MTC-060-3BD18	n/a	11.25	1.102	0.66	2.95	5.88	18.13	17.7	2.021	0.625	2.44	2.375
MTC-075-3BD18	11.25	12.25										
MTC-100-3BD18	12.25	13.75	1.18	0.81	3.15	7.25	21.02	21.42	2.45	0.75	2.83	2.875
MTC-125-3BD18	n/a	14.5										
MTC-150-3BD18	14.5	16.5	1.38	0.81	3.35	8.5	22.97	23.43	2.88	0.875	3.46	3.375
MTC-200-3BD18	16.5	20										
MTC-250-3D18	n/a	25	1.575	0.81	3.35	8.5	23	24	2.88	0.875	4.25	3.375
MTC-300-3D18												

* Various frame sizes have 2 or 4 mounting holes per mounting foot.

** AA dimension is conduit fitting size.

F₁ mounting shown; some frame sizes are F₁/F₂ convertible; refer to T-frame "Motor Specifications" table. (F₂ mounting = conduit entrance on right side facing shaft.)

MTC MOTOR DIMENSIONS (CONTINUED) – (DIMENSIONS = INCHES)

MTC EPACK TC-FRAME THREE-PHASE MOTOR & C-FLANGE DIMENSIONS

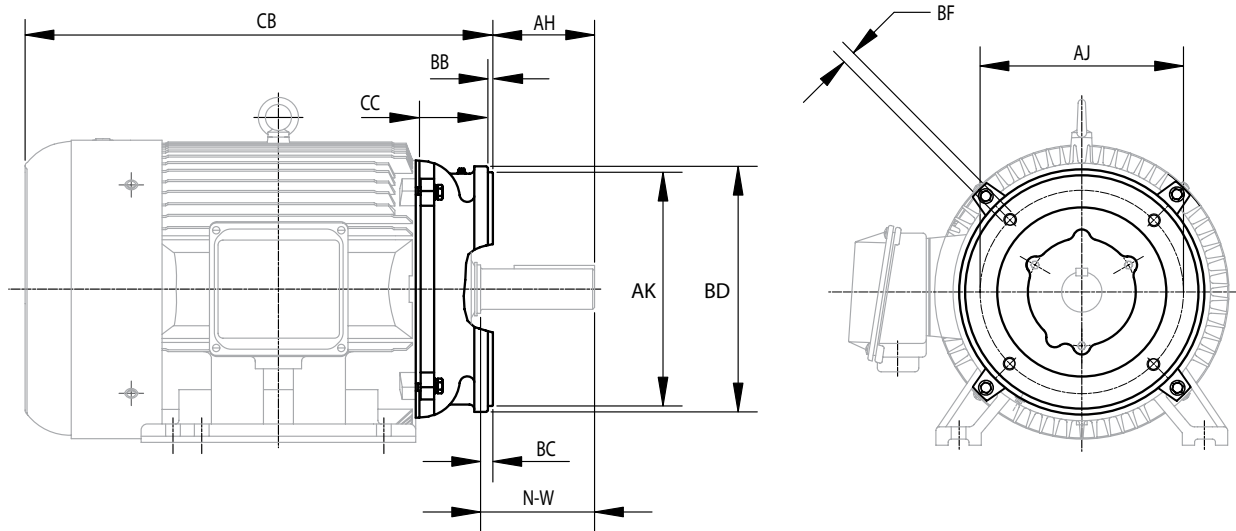

TC-frame motors are T-frame EPACK motors with C-flange accessory kits installed. For more information about the C-flange accessory kits, refer to Chapter 4: Accessories.

Dimensions (inches) - EPACK T-Frame Motor C-Flange Kits											
Part Number	Frame	AH ⁽²⁾	AJ	AK	BB	BC ⁽²⁾	BD	BF	CB ⁽²⁾	CC	N-W ⁽²⁾
MTA-CFACE-140TC⁽¹⁾	143T	1.96	5.875 ⁽¹⁾	4.5 ⁽¹⁾	0.16	0.12	6.5	3/8-16	10.51	1.43	2.25
	145T								11.62		
MTA-CFACE-180TC	182T	2.62	7.25	8.5	0.25	0.12	9	1/2-13	12.49	1.17	2.75
	184T								13.49		
MTA-CFACE-210TC	213T	3.12	7.25	8.5	0.25	0.25	9	1/2-13	15.77	1.45	3.38
	215T								17.37		
MTA-CFACE-250TC	254T	3.75	7.25	8.5	0.25	0.25	10	1/2-13	19.54	2.89	4
	256T								21.31		
MTA-CFACE-280TC	284T	4.38	9	10.5	0.25	0.25	11.25	1/2-13	22.26	3.26	4.62
	286T								23.80		
MTA-CFACE-320TC	324T	5	11	12.5	0.25	0.25	14	5/8-11	24.95	3.67	5.25
	326T								26.24		
MTA-CFACE-360TC	364T	5.62	11	12.5	0.25	0.25	14	5/8-11	27.06	4.06	5.88
	365T								28.49		
MTA-CFACE-400TC	405T	7	11	12.5	0.25	0.25	15.5	5/8-11	31.35	4.33	7.25
MTA-CFACE-444TC	444T	8.25	14	16	0.25	0.25	18	5/8-11	34.27	4.11	8.5
	445T								36.25		
MTA-CFACE-447TC	445/7T	8.25	14	16	0.25	0.25	18	5/8-11	39.78	4.11	8.5
MTA-CFACE-449TC	449T	8.248	14	16	0.26	0.26	17.72	5/8-11	47.26	4.35	8.5

1) Mounting bolt holes for MTA-CFACE-140TC are located outside of the highest C-face flange surface (dimension AJ > AK).

2) Motor dependent dimensions apply only to IronHorse MTC-xxx-xxxxx(CK) motors.

MTC JUNCTION BOX DIMENSIONS

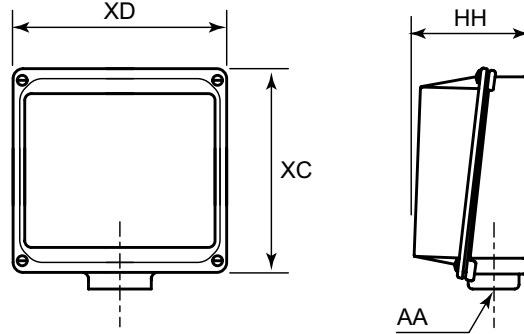

Junction Box Dimensions (in)				
Frame Size *	XD (Width)	XC (Height)	HH (Depth)	AA (Conduit Hole) (NPT)
143T	4.1	4.5	2.3	3/4
145T				
182T	4.6	5.0	2.6	1
184T				
213T				
215T				
254T	6.3	7.2	3.3	1-1/2
256T				
284T				
286T				
324T	9	10.6	5.3	2
326T				
364T				
365T				3
405T	9.8	11.7	7.1	3 (2 openings)
444T	11.3			
445T				
445/7T				
449T				

* TC-frame motors have the same junction boxes as the comparable T-frame motors.

MTC MOTORS DECIBEL LEVELS

The decibel (sound) level of an IronHorse® motor should be measured after initial startup, after 30 days, and after six months of use. Decibel levels should remain fairly consistent and can be an indication of misalignment and premature bearing wear. If the measured decibel level for your IronHorse model exceeds the value listed below by more than 10%, contact AutomationDirect or a local motor service technician found at www.easa.com.

MTC Average T-Frame Decibel Levels		
Frame Size *	HP	Noise Level: Lw dB(A) @ 1m
		MTC
143T	1	64.0
145T	1-1/2	68.0
	2	68.8
182T	2	–
182T	3	74.0
184T	5	73.0
213T	7-1/2	78.4
215T	10	74.3
254T	15	74.6
256T	20	74.0
284T	25	75.0
286T	30	76.1
324T	40	76.4
326T	50	77.0
364T	60	77.1
365T	75	78.0
405T	100	78.1
444T	125	78.3
445T	150	79.4
445/7T	200	79.4
449T	250	81.0
	300	81.4

* TC-frame motors have the same sound ratings as the comparable T-frame motors.

C-FLANGE KITS FOR MTC EPACT THREE-PHASE MOTORS

C-FLANGE KITS

Any IronHorse MTC EPAct T-frame cast-iron motor from 1–300hp can be converted to C-face mounting by using a cast iron C-flange kit. These kits are field installable and include the C-faces and mounting bolts.

C-FLANGE DIMENSIONS

C-flange dimensions are shown in Chapter 2 (Mounting & Initial Startup) along with TC-frame motor dimensions.



MTA T-Frame C-Flange Kit



Authorized EASA service centers are equipped with the necessary equipment to quickly and inexpensively install C-Face kits. Visit the EASA website at www.easa.com to find the nearest authorized service center. C-faces must be installed by an EASA motor shop in order to maintain the motor warranty.

C-FLANGE KITS FOR MTC EPACT THREE-PHASE MOTORS (CONTINUED)

EPAct T-Frame Three-Phase Motor C-Flange Kits				
Part Number (1)	Fits Frame	Fits Motor (1)	Motor HP	Shipping Weight (lb)
MTA-CFACE-140TC	143T & 145T	MTC-001-3BD12 MTC-001-3BD18 MTC-1P5-3BD18 MTC-1P5-3BD36 MTC-002-3BD18 MTC-002-3BD36	1 1 1-1/2 1-1/2 2 2	6
MTA-CFACE-180TC	182T & 184T	MTC-1P5-3BD12 MTC-002-3BD12 MTC-003-3BD18 MTC-003-3BD36 MTC-003-3BD36 MTC-005-3BD36	1-1/2 2 3 3 5 5	12
MTA-CFACE-210TC	213T & 215T	MTC-003-3BD12 MTC-005-3BD12 MTC-7P5-3BD18 MTC-7P5-3BD36 MTC-010-3BD18 MTC-010-3BD36	3 5 7-1/2 7-1/2 10 10	12
MTA-CFACE-250TC	254T & 256T	MTC-7P5-3BD12 MTC-010-3BD12 MTC-015-3BD18 MTC-020-3BD18	7-1/2 10 15 20	24
MTA-CFACE-280TC	284T & 286T	MTC-25-3BD18 MTC-30-3BD18	25 30	30
MTA-CFACE-320TC	324T & 326T	MTC-40-3BD18 MTC-50-3BD18	40 50	48
MTA-CFACE-360TC	364T & 365T	MTC-60-3BD18 MTC-75-3BD18	60 75	50
MTA-CFACE-400TC	405T	MTC-100-3BD18	100	123
MTA-CFACE-444TC	444T & 445T	MTC-125-3BD18 MTC-150-3BD18	125 150	133
MTA-CFACE-447TC	445/7T	MTC-200-3BD18	200	133
MTA-CFACE-449TC	449T	MTC-250-3D18 MTC-300-3D18	250 300	147

1) MTA-CFACE C-flange kits will NOT fit MTCP2 Premium-Efficiency motors.



Authorized EASA service centers are equipped with the necessary equipment to quickly and inexpensively install C-Face kits. Visit the EASA website at www.easa.com to find the nearest authorized service center.

MTC MOTORS BEARING SIZE INFORMATION

All IronHorse® cast-iron motors use premium name-brand bearings (NSK, NTN, or SKF). Below is a bearing size chart listing the type of bearings used in each frame size of IronHorse MTC motors. The bearing types are also listed on the motor nameplate.

MTC Motors Bearing Size Chart		
Frame Size *	Drive End Bearing	Opposite Drive End Bearing
143T	6205-ZZ	6205-ZZ
145T		
182T	6306-ZZ	6206-ZZ
184T		
213T	6308-ZZ	6308-ZZ
215T		
254T	6309	6209
256T		
284T	6311	6309
286T		
324T	6312	6311
326T		
364T	6313	6312
365T		
404T	NU316	6313
405T		
444T	NU318	
445T		
445/7T	NU319	
449T	NU320	6320

** TC-frame motors have the same bearings as the comparable T-frame motors.*

MTF Farm-Duty T-Frame Single-Phase Motors – Features and Specifications



IronHorse® single-phase farm-duty motors are available from 2hp to 5hp. All models have a TEFC housing (steel frame with iron end bells) that is fully gasketed for use in dirty environments. All motors are NEMA L design.

All models include a class-10 manual-reset locked-rotor thermal protector (motor thermal overload protection must be provided separately).



WE RECOMMEND DISCONNECTING POWER TO THE MOTOR BEFORE RESETTING THE THERMAL PROTECTOR. DO NOT RESET MORE THAN TWICE IN SUCCESSION. THE MOTOR MUST COOL TO 40°C (104°F) BEFORE A THIRD RESET.

CAST-IRON T-FRAME 1-PHASE FARM-DUTY MOTOR SPECIFICATIONS

Motor Specifications – Single-Phase Farm-Duty Motors (60Hz)									
Part Number	HP	Base RPM	Voltage*	Service Factor	NEMA Design	NEMA Frame	Housing	F.L. Amps @ 230VAC	Approx Weight (lb)
MTF-002-1C18-182	2	1800	230VAC ±10%	1.15 @ 230VAC 1.0 @ 208VAC	L	182T	TEFC IP55	8.5	74
MTF-003-1C18	3					184T		12.9	85
MTF-005-1C18	5					184T		21.2	105

* Operate on 230VAC +/- 10% (1.15 @ 230VAC; 1.0 S.F. @ 208V), single-phase power only.

CAST-IRON T-FRAME 1-PHASE FARM-DUTY MOTOR PERFORMANCE DATA

Performance Data – Single-Phase Farm-Duty Motors (60Hz)											
Part Number	HP	F.L. RPM	Current @ 230V (Amps)			Torque (lb-ft)			F.L. Efficiency (%)	F.L. Power Factor	Rotor Inertia (lb-ft ²)
			230V No Load	Full Load	Locked Rotor	Full Load	Locked Rotor	Break down			
MTF-002-1C18-182	2	1725	2.7	8.5	70.0	6.04	20.54	15.10	82.5	0.92	0.35
MTF-003-1C18	3		3.9	12.9	95.0	9.11	32.80	23.69	81.5	0.93	0.60
MTF-005-1C18	5		6.6	21.2	160.0	15.30	58.14	36.72	81.0	0.90	0.81

MOTOR DIMENSIONS

(DIMENSIONS = INCHES)

MTF T-FRAME SINGLE-PHASE FARM-DUTY MOTOR DIMENSIONS

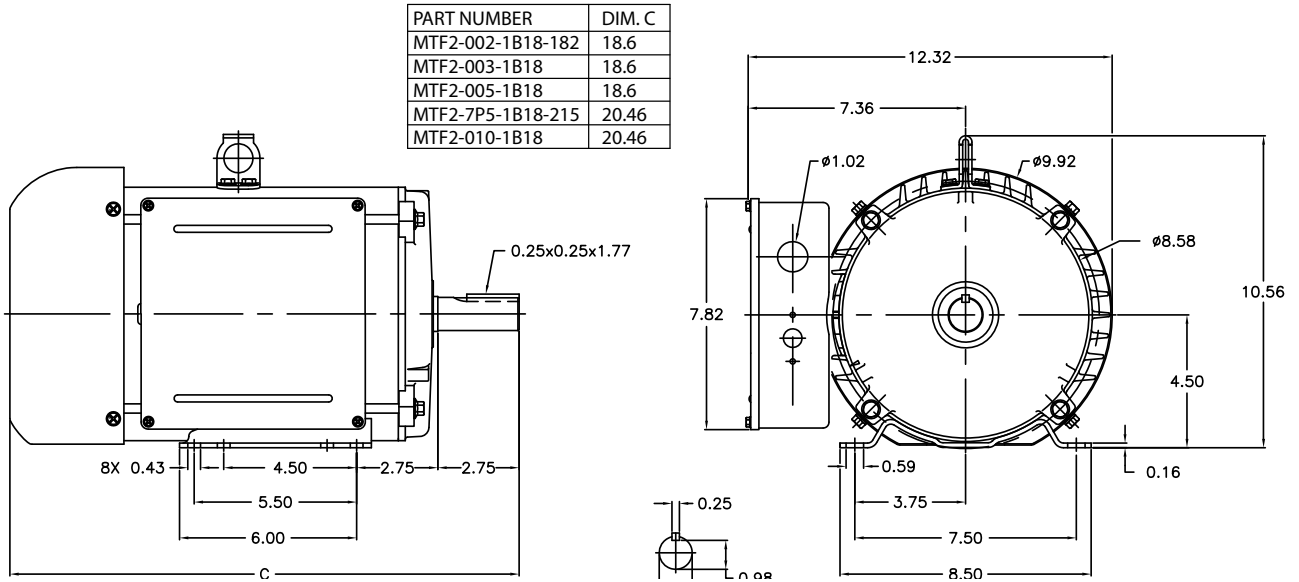

TERMINAL AND WIRING DIAGRAMS

MTF FARM-DUTY MOTORS

2-5hp 1Ø Farm-Duty models ; 6-Lead, 230 VAC

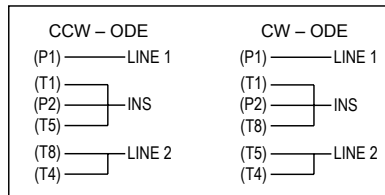

REPLACEMENT PARTS

CAPACITORS AND CENTRIFUGAL SWITCHES FOR IRONHORSE® SINGLE-PHASE MOTORS

Single phase motors use capacitors to provide starting torque when power is first applied to the motor. When the motor begins to turn, the start capacitor is no longer need and is taken out of the circuit by a centrifugal switch. In addition to the start capacitor, 1-1/2 hp and larger IronHorse single-phase motors have run capacitors to allow the motor to develop higher running torque and greater efficiency. Run capacitors also help improve the motor power factor.

MTF ACCESSORY LOCATIONS

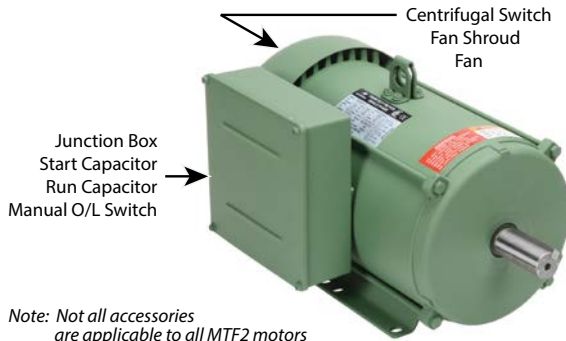

Note: Not all accessories are applicable to all MTF2 motors

SPARE/REPLACEMENT PARTS FOR MTF SINGLE-PHASE FARM-DUTY MOTORS

MTF Single-Phase Motor Spare/Replacement Parts *						
Part Number	Accessory Type	Capacitance (µF)	Rated Voltage	Dimension Height x Ø (in[mm])	Applicable Motor Number	Motor HP
MTA-CAP-16	Start capacitor	200	300	3.39 x 1.81 [86.1 x 46.0]	MTF-002-1C18-182	2
MTA-CAP-17		300		3.39 x 1.81 [86.1 x 46.0]	MTF-003-1C18	3
MTA-CAP-18		500		4.33 x 1.97 [110.0 x 50.0]	MTF-005-1C18	5
MTA-CAP-19	Run capacitor	35	450	3.96 x 1.77 [100.6 x 45.0]	MTF-002-1C18-182	2
MTA-CAP-20		40		3.96 x 1.97 [100.6 x 50.0]	MTF-003-1C18	3
MTA-CAP-21		50		4.17 x 1.97 [106.0 x 50.0]	MTF-005-1C18	5
MTA-CSW-05	Centrifugal switch	n/a	250		MTF-002-1C18-182	2
MTA-CSW-06					MTF-003-1C18	3
MTA-CSW-07					MTF-005-1C18	5
MTA-MOL-1**	Manual overload switch	n/a	250		MTF-002-1C18-182	2
MTA-MOL-2**					MTF-003-1C18	3
MTA-MOL-3**					MTF-005-1C18	5
MTAF-JBOX-180	Junction box				MTF-xxx-1C18-xxx	all
MTAF-FAN-182	Fan		n/a		MTF-002-1C18-182	2
MTAF-FAN-184		MTF-003-1C18			3	
MTAF-FAN-184-2		MTF-005-1C18			5	
MTAF-SHROUD-180	Fan shroud				MTF-xxx-1C18-xxx	all

* These accessories are spare/replacement components only for IronHorse MTF series single-phase farm-duty motors.

** MTA-MOL-1 = JOEMEX TC4-0-E-1-44, V07-1; MTA-MOL-2 = JOEMEX TC4-0-E-1-44, V06-1;

MTA-MOL-3 = JOEMEX TC4-0-E-1-40, V08-1

JUNCTION BOX DIMENSIONS

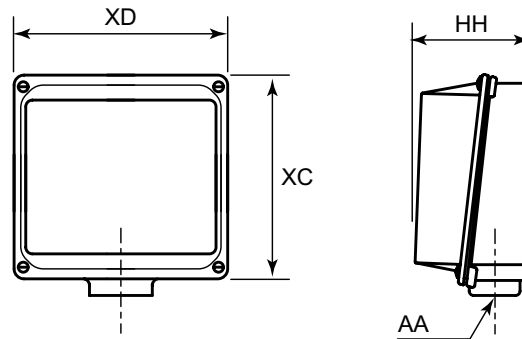

Junction Box Dimensions (in)				
Frame Size *	XD (Width)	XC (Height)	HH (Depth)	AA (Conduit Hole) (NPT)
56	n/a	n/a	n/a	1/2
143T				3/4
145T				3/4
182T	7.8	7.8	2.7	1
184T				1
213T	n/a	n/a	n/a	1-1/2
215T				1-1/2
254T				1-1/2
256T				1-1/2
284T				1-1/2
286T				1-1/2
324T				1-1/2
326T	n/a	n/a	n/a	2
364T				2
365T				2
405T	n/a	n/a	n/a	3
444T				3
445T				3
445/7T				3
449T	n/a	n/a	n/a	3 (2 openings)

* TC-frame motors have the same junction boxes as the comparable T-frame motors.

**BLANK
PAGE**

