

 AUTOMATIONDIRECT.com

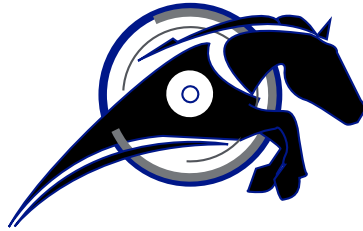

IRONHORSE™

GSD1 SERIES DC DRIVES USER MANUAL

USER MANUAL NUMBER: GSD1-48_UMP



~ **WARNING** ~

Thank you for purchasing automation equipment from Automationdirect.com®, doing business as AutomationDirect. We want your new automation equipment to operate safely. Anyone who installs or uses this equipment should read this publication (and any other relevant publications) before installing or operating the equipment.

To minimize the risk of potential safety problems, you should follow all applicable local and national codes that regulate the installation and operation of your equipment. These codes vary from area to area and usually change with time. It is your responsibility to determine which codes should be followed, and to verify that the equipment, installation, and operation is in compliance with the latest revision of these codes.

At a minimum, you should follow all applicable sections of the National Fire Code, National Electrical Code, and the codes of the National Electrical Manufacturer’s Association (NEMA). There may be local regulatory or government offices that can also help determine which codes and standards are necessary for safe installation and operation.

Equipment damage or serious injury to personnel can result from the failure to follow all applicable codes and standards. We do not guarantee the products described in this publication are suitable for your particular application, nor do we assume any responsibility for your product design, installation, or operation.

Our products are not fault-tolerant and are not designed, manufactured or intended for use or resale as on-line control equipment in hazardous environments requiring fail-safe performance, such as in the operation of nuclear facilities, aircraft navigation or communication systems, air traffic control, direct life support machines, or weapons systems, in which the failure of the product could lead directly to death, personal injury, or severe physical or environmental damage (“High Risk Activities”). AutomationDirect specifically disclaims any expressed or implied warranty of fitness for High Risk Activities.

For additional warranty and safety information, see the Terms and Conditions section of our catalog. If you have any questions concerning the installation or operation of this equipment, or if you need additional information, please call us at 770-844-4200.

This publication is based on information that was available at the time it was printed. At AutomationDirect we constantly strive to improve our products and services, so we reserve the right to make changes to the products and/or publications at any time without notice and without any obligation. This publication may also discuss features that may not be available in certain revisions of the product.

TRADEMARKS

This publication may contain references to products produced and/or offered by other companies. The product and company names may be trademarked and are the sole property of their respective owners. AutomationDirect disclaims any proprietary interest in the marks and names of others.

Copyright© 2015-2021 Automationdirect.com® Incorporated

All Rights Reserved

No part of this manual shall be copied, reproduced, or transmitted in any way without the prior, written consent of Automationdirect.com® Incorporated. AutomationDirect retains the exclusive rights to all information included in this document.

PUBLICATION HISTORY

User Manual Publication History		
Issue	Date	Description
Third Edition	05/02/19	Addition of 15A NEMA4X drive
Third Ed. Rev A	02/24/21	Multiple minor corrections throughout manual

CONTENTS

~ WARNING ~ 2

Trademarks. 2

Publication History 2

GSD1 DC Drives User Manual Overview. 4

Selection and Specifications 5

Dimensions. 6

Installation and Wiring 7

Operational Description: 0 to 10 VDC Analog Reference Signal to GSD1 11

Trim Pot Adjustments 12

Troubleshooting 12

GSD1 DC DRIVES USER MANUAL OVERVIEW

OVERVIEW OF THIS PUBLICATION

The IronHorse GSD1 Series DC Drives User Manual describes the installation, configuration, and methods of operation of the GSD1 Series DC Drives.

All information contained in this manual is intended to be correct. However, information and data in this manual are subject to change without notice. AutomationDirect (ADC) makes no warranty of any kind with regard to this information or data. Further, ADC is not responsible for any omissions or errors or consequential damage caused by the user of the product. ADC reserves the right to make manufacturing changes which may not be included in this manual.

WHO SHOULD READ THIS USER MANUAL

This manual contains important information for those who will install, maintain, and/or operate any of the GSD1 Series DC Drives.

TECHNICAL SUPPORT

BY TELEPHONE: 800-633-0405 (MON.–FRI., 9:00 A.M.–6:00 P.M. E.T.)

ON THE WEB: WWW.AUTOMATIONDIRECT.COM

Our technical support group is glad to work with you in answering your questions. If you cannot find the solution to your particular application, or, if for any reason you need additional technical assistance, please call Technical Support at 800-633-0405. We are available weekdays from 9:00 a.m. to 6:00 p.m. Eastern Time.

We also encourage you to visit our web site where you can find technical and non-technical information about our products and our company. Visit us at www.automationdirect.com.

SPECIAL SYMBOLS



NOTE: When you see the “notepad” icon in the left-hand margin, the paragraph to its immediate right will be a special note.



WARNING: WHEN YOU SEE THE “EXCLAMATION MARK” ICON IN THE LEFT-HAND MARGIN, THE PARAGRAPH TO ITS IMMEDIATE RIGHT WILL BE A WARNING. THIS INFORMATION COULD PREVENT INJURY, LOSS OF PROPERTY, OR EVEN DEATH (IN EXTREME CASES).

IRONHORSE GSD1 SERIES DC DRIVES GENERAL INFORMATION

STANDARD FEATURES

- Provides smooth variable speed capability for mobile equipment.
- Automatic compensation holds motor speed steady even if the load varies or battery voltage declines.
- Adjustable maximum speed, minimum speed, current limit, IR compensation, and motor acceleration.
- Inhibit terminal permits optional start-stop without breaking battery / power lines.
- Speed potentiometer, knob, and dialplate included.
- Enclosed models (GSD1-48-10N4X, GSD1-24-15N4X-R) are rated NEMA 4X.



Carefully check the DC Drive for shipping damage. Report any damage to the carrier immediately. Do not attempt to operate the drive if visible damage is evident to either the circuit or to the electronic components.

SELECTION AND SPECIFICATIONS

GSD1 Series DC Drives	
12VDC @ 10A	1/50 – 1/8 hp motor
12VDC @ 15A	1/50 – 3/16 hp motor
24VDC @ 10A	1/50 – 1/4 hp motor
24VDC @ 15A	1/50 – 5/16 hp motor
36VDC @ 10A	1/50 – 3/8 hp motor
48VDC @ 10A	1/50 – 1/2 hp motor
12VDC @ 20A	1/50 – 1/4 hp motor
24VDC @ 20A	1/50 – 1/2 hp motor
36VDC @ 20A	1/50 – 3/4 hp motor
48VDC @ 20A	1/50 – 1 hp motor

GSD1 Series DC Drives – Selection & Specifications				
Model	GSD1-24-15N4X-R	GSD1-48-10C	GSD1-48-10N4X	GSD1-48-20C
Package Configuration	NEMA 4X	open frame	NEMA 4X	open frame
Power Quality Form Factor	1.05			
Input Voltage **	12–24 VDC ±15%	12/24/36/48 VDC ±15% (jumper selectable)		
Output Voltage	0-12/24 VDC	0–12/24/36/48 VDC		
Motor Rating (hp)	1/50 – 5/16	1/50 – 1/2		1/50 – 1
Output Current (continuous)	15A (DC)	10A (DC)		20A (DC)
Current Overload Capacity	200% for 10s; 150% for 60s			
Current Limit	adjustable to 200% of motor Full Load Current, up to 200% of control current rating			
Speed Adjustment ***	5kΩ potentiometer or 0–10VDC*** input signal			
Speed Range	30:1			
Speed Regulation	1% of base speed via adjustable IR compensation trim pot			
Maximum Speed	adjustable from 50% to 100% of base speed			
Minimum Speed	0–30% of adjustable maximum speed			
Acceleration	adjustable from 0–10s			
Deceleration	0.5s (non-adjustable)			
Dynamic Braking	no			
Plugging Capability ****	no			
Internal Operating Frequency	18kHz			
Power Connections (P1)	Euro-style terminal block (10–14 AWG)	Euro-style terminal block (14–28 AWG)		Euro-style terminal block (10–14 AWG)
Signal Connections (P2)	Euro-style terminal block (14–28 AWG)			
External Fusing Required	DC-rated @ 150% motor Full Load Current (up to 150% Continuous Output Current rating of drive)			
Operating Temperature	-30 to 65°C [-22 to 140°F] for Chassis / -15 to 45°C [5 to 113°F] for Enclosed			
Thermal Protection	none			
Mounting Orientation	Can be mounted in any orientation			
Corrosive Gases	NOT compatible with any corrosive gases			
Package Configuration	Black anodized aluminum extrusion			
Weight	40oz [1049g]	8oz [227g]	40oz [1049g]	8oz [227g]
Agency Approvals	RoHS			
Optional Accessories *				
Replacement Potentiometer	GSDA-5K			
Digital Potentiometer	GSDA-DP			
Manual Reverse Switch	GSDA-MREV			-
<p>* For accessories details, refer to the "GSD Series DC Drives Accessories" section at automationdirect.com.</p> <p>** Input power supply must not exceed recommended voltage, or it may damage the GSD1 drive. Linear power supply can be sized per drive voltage and motor full load current. Switched power supply should be sized per drive voltage and double the motor full load current.</p> <p>*** For 0–10 VDC input signal, please refer to "Operational Description: 0 to 10 VDC Analog Reference Signal to GSD1" on page 11</p> <p>**** Plugging is a method of rapidly changing motor direction by reversing motor armature polarity, while the motor is still running.</p>				

DIMENSIONS

inches [mm]

GSD1-48-10C AND GSD1-48-20C

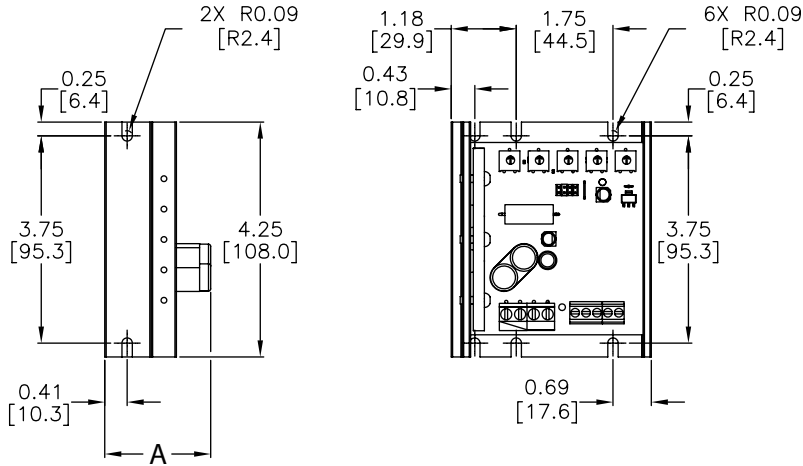

Model	A
GSD1-48-10C	1.70 [43.1]
GSD1-48-20C	1.92 [48.7]

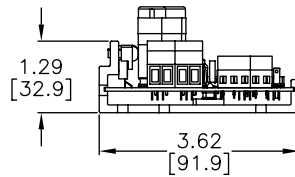

GSD1-48-10N4X AND GSD1-24-15N4X

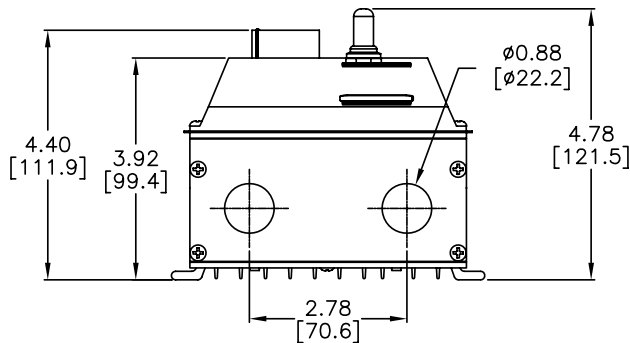
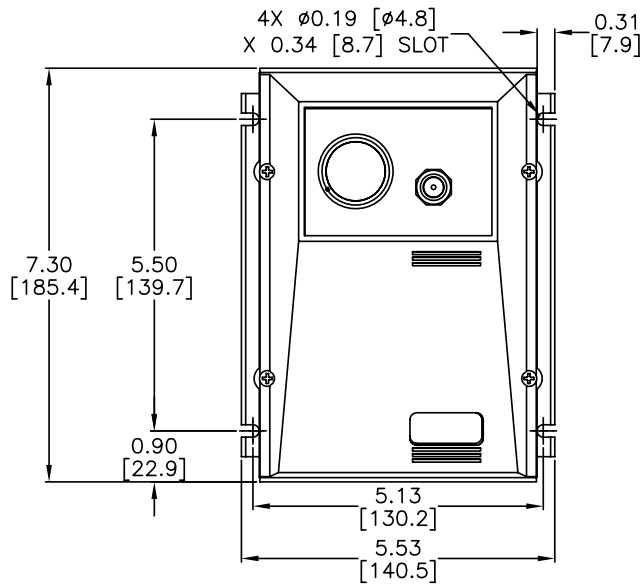

INSTALLATION AND WIRING



Install open-frame drives in an enclosure with a volume at least three times the volume of the open-frame drive.



Do not mount controller where ambient temperature is outside the range of -30 to 60 °C (-22 to 140 °F) for chassis models, or -15 to 45 °C (5 to 113 °F) for enclosed models.



IMPROPER INSTALLATION OR OPERATION OF THIS DC DRIVE MAY CAUSE INJURY TO PERSONNEL OR DRIVE FAILURE. THE DRIVE MUST BE INSTALLED IN ACCORDANCE WITH LOCAL, STATE, AND NATIONAL SAFETY CODES. MAKE CERTAIN THAT THE POWER SUPPLY IS DISCONNECTED BEFORE ATTEMPTING TO SERVICE OR REMOVE ANY COMPONENTS!!! IF THE POWER DISCONNECT POINT IS OUT OF SIGHT, LOCK IT IN DISCONNECTED POSITION AND TAG IT TO PREVENT UNEXPECTED APPLICATION OF POWER. ONLY A QUALIFIED ELECTRICIAN OR SERVICE PERSONNEL SHOULD PERFORM ANY ELECTRICAL TROUBLESHOOTING OR MAINTENANCE. AT NO TIME SHOULD CIRCUIT CONTINUITY BE CHECKED BY SHORTING TERMINALS WITH A SCREWDRIVER OR OTHER METAL DEVICE.



BEFORE ATTEMPTING TO WIRE THE DC DRIVE, MAKE SURE ALL POWER IS DISCONNECTED. RECHECK CODE DESIGNATION TO ASSURE PROPER VOLTAGE IS PRESENT FOR THE DC DRIVE. CAUTION SHOULD BE USED IN SELECTING PROPER WIRE SIZE FOR CURRENT AND VOLTAGE DROP; MINIMUM WIRE SIZE 14AWG FOR 10 AMP MODELS AND 12AWG FOR 20 AMP MODELS.



DO NOT REVERSE POSITIVE AND NEGATIVE BATTERY / POWER LEADS, AS THIS WILL DAMAGE THE DC DRIVE. TO CHANGE MOTOR DIRECTION, INTERCHANGE THE POSITIVE AND NEGATIVE MOTOR ARMATURE LEADS.



CAUTION!! TURN POWER OFF WHILE MAKING WIRING CONNECTIONS.



CAUTION!! SET THE VOLTAGE SELECTION JUMPER TO MATCH THE SUPPLY VOLTAGE. AN INCORRECT JUMPER SETTING WILL NOT CAUSE DAMAGE TO THE DRIVE, BUT WILL AFFECT OVERALL SPEED, MAXIMUM SPEED AND IR COMPENSATION ADJUSTMENTS.

FUSING

Externally fuse the +Battery input line with [Littlefuse 314 series](#) or [Bussman ABC series](#) or equivalent fuses designed for use with motors and motor control systems; rated for the lesser of:

- 1) 200% of the continuous current rating of the drive, or
 - 2) 150% of the motor full-load current.
- (Fast-blow fuses are NOT recommended.) (AutomationDirect sells ABC series fuses.)

CURRENT LIMIT SETTING AND CURRENT LIMIT (TRIP) OUTPUT

Please note the following recommendations regarding the Current Limit (Trip) Output and Setting:

- The Current Limit Output can be used to inhibit the drive or break the power connection to the drive.
- The Current Limit Output threshold is the same as the Current Limit Setting.
- To properly adjust the CURRENT LIMIT Setting, a DC ammeter should be placed in series with the armature line. This meter can be removed after the DC Drive is adjusted.
- The Current Limit Output is immediate, without time delay, and is NOT retentive.
- Use with 12VDC relay. In order to maintain a current limit fault, use a latching relay.
- Source voltage from terminal P2-1.
- Current Limit Trip Output sinks to terminal P2-4 (50VDC@0.3A).
- Recommended use with Inhibit, terminals P2-4 and P2-5.
- If you connect the current limit relay to the Pot HI (P2-1), supply voltage will be 10V, regardless of the supply voltage to the drive. If the relay is connected to the supply voltage, the relay voltage needs to match the supply voltage. The Current Limit Output is capable of up to 100V.

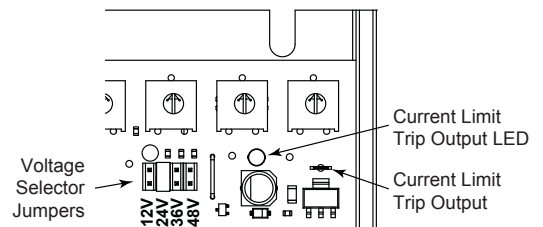

TERMINAL BLOCKS

GSD1 Wiring Terminals		
Type	Wire Range*	Tightening Torque
Barrier terminal block (P1) (Power)	14 – 28 AWG (10A)	7.0 lb-in [8.0 kg-cm]
	10 – 14 AWG (20A)	8.5 lb-in [9.8 kg-cm]
Barrier terminal block (P2)	14 – 28 AWG	7.0 lb-in [8.0 kg-cm]
*Wire range of the terminal. See Installation and Wiring above for minimum wire sizes.		

WIRING

Refer to the following wiring diagrams for proper connection of DC Voltage, Armature, and Speed Pot wiring to the DC drive.

BASIC WIRING DIAGRAMS



Speed pots can be replaced by 0-10V analog signals (PLC, etc.). For 0-10 VDC input signal, please refer to "Operational Description: 0 to 10 VDC Analog Reference Signal to GSD1" on page 11."

GSD1-48-xxC BASIC WIRING DIAGRAM

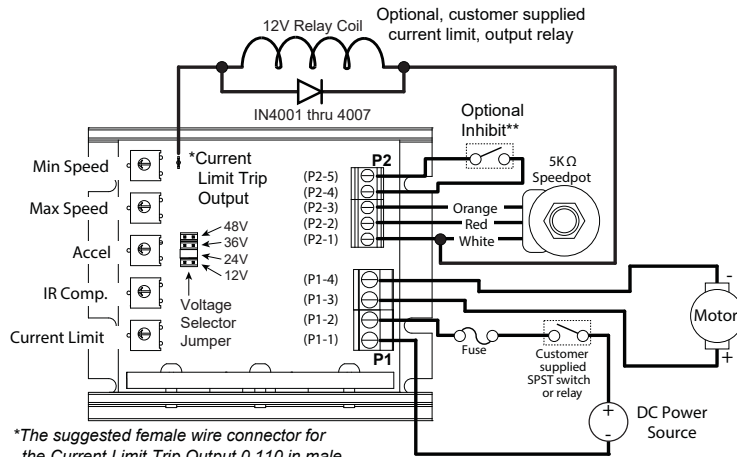

*The suggested female wire connector for the Current Limit Trip Output 0.110 in male spade terminal is Molex Inc. P/N 190030024

** Inhibit Circuit (P2-4 to P2-5): 7-10 VDC @ 0.2-1 mA; Refer to "Control Inhibit Wiring Diagrams" for Control Inhibit wiring details.

GSD1 Series Terminals		
Terminal Number	Description	Terminal Marking
P1-1	- Battery	(-B)
P1-2	+ Battery	(+B)
P1-3	+ Armature	(+A)
P1-4	- Armature	(-A)
P2-1	Potentiometer High	(HI)
P2-2	Potentiometer Wiper	(WP)
P2-3	Potentiometer Low	(LO)
P2-4	Common	(COM)
P2-5	Inhibit	(INH)

GSD1-48-10N4X BASIC WIRING DIAGRAM

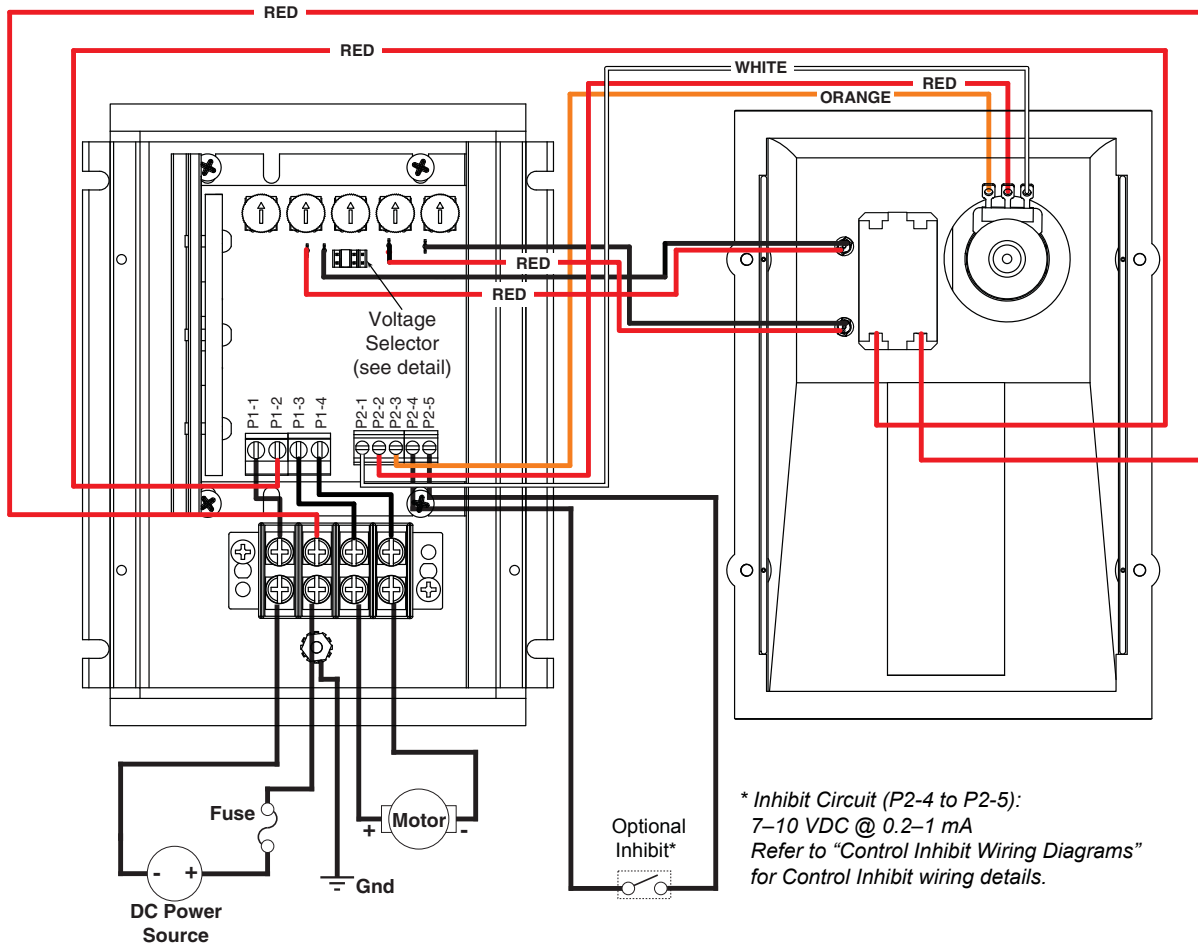

* Inhibit Circuit (P2-4 to P2-5): 7-10 VDC @ 0.2-1 mA; Refer to "Control Inhibit Wiring Diagrams" for Control Inhibit wiring details.

GSD1-24-15N4X-R BASIC WIRING DIAGRAM

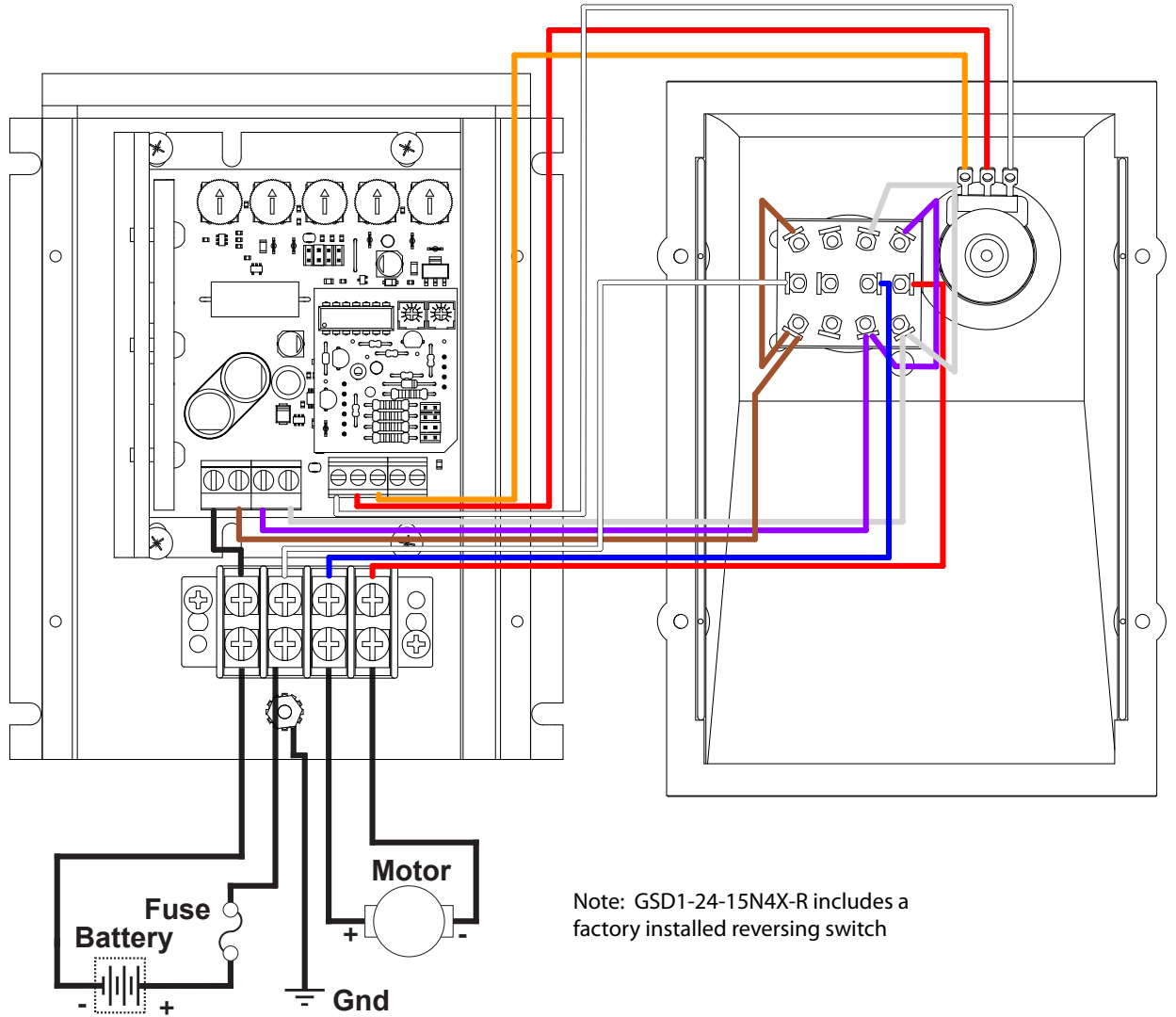

REVERSING WIRING DIAGRAMS



CAUTION: WHEN REVERSING A SPINNING PERMANENT MAGNET DC MOTOR, CAUTION MUST BE TAKEN THAT THE RESULTING CURRENT THROUGH THE ARMATURE OF THE MOTOR DOES NOT EXCEED THE OVERLOAD RATINGS OF THE DC DRIVE, OR THE DEMAGNETIZE RATING OF THE MOTOR BEING REVERSED.



CAUTION: ENSURE THAT MOTOR ROTATION HAS STOPPED BEFORE REVERSING THE APPLIED VOLTAGE.



Speed pots can be replaced by 0-10V analog signals (PLC, etc.). For 0-10 VDC input signal, please refer to “Operational Description: 0 to 10 VDC Analog Reference Signal to GSD1” on page 11.”

GSD1-48-xxC REVERSING WIRING DIAGRAM

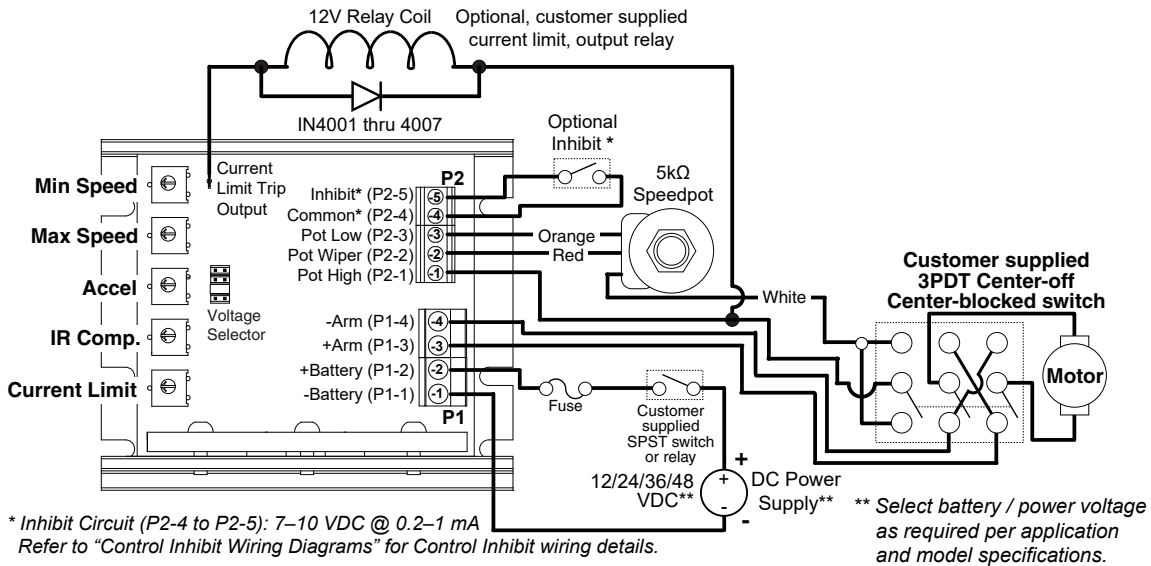

CONTROL INHIBIT WIRING DIAGRAMS



Always use a shielded cable when connecting to the inhibit terminal. The shield of the cable should connect to the Common terminal of the DC Drive.



Speed pots can be replaced by 0-10V analog signals (PLC, etc.). For 0-10 VDC input signal, please refer to “Operational Description: 0 to 10 VDC Analog Reference Signal to GSD1” on page 11.”

GSD1-48-xxC & GSD1-24-10N4X-R - CONTROL INHIBIT WIRING DIAGRAMS

Using inhibit input
provides fast start-stop by bypassing accel circuit

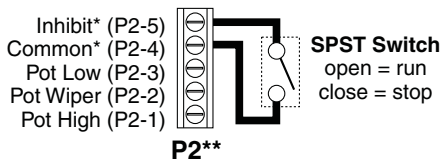

Inhibit via speedpot
provides starting and stopping through accel parameters

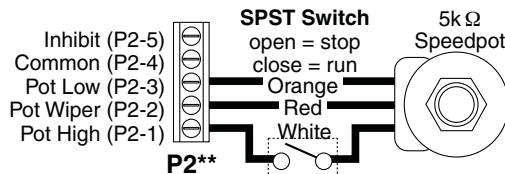

* Inhibit Circuit (P2-4 to P2-5): 7–10 VDC @ 0.2–1 mA

** Use shielded cable when connecting to the Inhibit terminal. Connect the cable shield to the Common terminal of P2.

OPERATIONAL DESCRIPTION: 0 TO 10 VDC ANALOG REFERENCE SIGNAL TO GSD1

IronHorse GSD1 drives, though advertised to work with a 0 to 10 volt reference, exhibit an offset in output response when used in this manner. With 0 to 10 VDC connected to the GSD1 drive, output voltage is zero volts until the analog reference value reaches two volts, where the GSD1 drive output voltage will begin to rise. As the analog reference voltage rises, the GSD1 drive output voltage rises in proportion and linear to the reference. At five volts reference the GSD1 drive output is 50%, and at 10 volts reference the output is 100% of the expected voltage. Adjustments to min and max speed have no effect on the observed behavior.

The installation of a 4.7k Ω resistor across Pot Hi (P2-1) and Pot Lo (P2-3) helps with GSD1 drive output voltage, but is NOT a perfect solution. With the resistor installed, GSD1 drive output voltage is proportional to the lower reference voltage with a linear output response to midscale, where 1 to 5 volts reference equals 10% to 50% output. The problem is that linearity suffers as reference voltage increases. If the drive is linear from 1 to 5 volts then output voltage is low at the top, where 10 volts reference equals roughly 90% output. If adjustments are made to provide 100% output at the top, then the drive ignores the falling reference voltage and runs fast at midscale, where 5 volts reference equals 55% output.

All GSD1 drives have some dead band built into the speed pot circuit which, when a speed pot is used, can be tuned out using the MIN trim pot. The physical connection of a speed pot also provides a current path so that the MIN trim pot is active in the circuit. When using a reference signal connected +Signal to Wiper and -Signal to Pot Lo, the current path for the MIN trim pot is lost and therefore no longer in the circuit; thus the need for a 4.7–5 k Ω resistor from Pot Hi to Pot Lo.

With a 0–10 VDC reference signal input, and with the MIN trim pot active, the MIN trim pot can be turned up to reduce or eliminate the dead band in the bottom end of the signal. However, this also has the effect of shifting the reference signal to effectively be a 2–12 VDC signal. The top of the reference (10–12 VDC) is ignored and the drive response becomes non-linear.

For most applications this is not an issue, as most do not operate in the bottom or top 20% of reference signal / speed range. However, for those applications that do, another fix is to scale the reference signal at the source to keep the effective reference signal always in the 0–10 VDC range. Changing from a 0–10 to a 0–8 VDC signal at the source, and turning up the MIN trim pot ~2V to offset dead band at the bottom, will operate the motor from 0–100% speed with a more linear response.

There is NO signal conditioning solution for the performance issue described in the GSD1 drive.

TRIM POT ADJUSTMENTS

Before the power is applied, set the voltage selection jumper to the correct voltage. An incorrect jumper setting will not damage the drive, but will affect the trim pot adjustments. The speed potentiometer and trim pots should be preset as follows:

TRIM POT PRESET

- 1) Preset Speed pot fully CCW.
- 2) Preset MAX trim pot CW 1/2 way.
- 3) Preset CURRENT LIMIT trim pot fully CW.
- 4) Preset MIN trim pot fully CCW.
- 5) Preset ACCEL trim pot CW 1/2 way.
- 6) Preset IR trim pot fully CCW.

DC power can now be applied to the system and the DC Drive adjusted as follows:

TRIM POT ADJUSTMENT

- 1) Increase the MIN trim pot CW until just before reaching an output voltage (deadband), or until the desired minimum speed is reached.
- 2) Turn the Speed pot fully CW and adjust the MAX trim pot until the desired maximum speed is reached.
- 3) Adjust the ACCEL trim pot to achieve the desired soft start time.
(CW rotation will increase accel time.)
- 4) Rotate the CURRENT LIMIT trim pot fully CCW. Apply a full load to the motor. While motor is stalled, adjust the CURRENT LIMIT trim pot CW until a desired current setting is obtained.
(Approximately 125% of rated motor current is recommended.)
- 5) For 10A models GSD1-48-10C:
Set the Speed pot to approximately 50%, and note the motor RPM. Load the motor to normal load condition and adjust the IR trim pot CW until motor RPM is equal to the unloaded speed.
For 15A and 20A models GSD1-24-15N4X-R and GSD1-48-20C:
Adjust the IR trim pot CW 1/2 way. If the motor speed is inconsistent (jumpy), rotate the IR trim pot CCW until the motor rotation becomes stable.
- 6) If the voltage selection jumper setting is changed, repeat Trim Pot Preset and Trim Pot Adjustment.

TROUBLESHOOTING

If a newly installed DC Drive will not operate, it is likely that a terminal connection is loose. Check the terminal connections and ensure that they are secure and correct. If the drive is still inoperative, refer to the Troubleshooting Table.

Troubleshooting		
Problem	Possible Cause(s)	Corrective Action
Motor doesn't run	<ol style="list-style-type: none"> 1) Incorrect or no power 2) Speed pot set at zero 3) Worn motor brushes 4) Current Limit set too low 	<ol style="list-style-type: none"> 1) Install proper power service 2) Rotate Speed pot fully CW 3) Replace motor brushes 4) Adjust Current Limit trim pot CW
Motor "hunts"	<ol style="list-style-type: none"> 1) Max trim pot set too high 2) IR Comp trim pot set too high 	<ol style="list-style-type: none"> 1) Refer to "Trim Pot Adjustment" 2) Refer to "Trim Pot Adjustment"
Motor runs uncontrollably at "full speed"	<ol style="list-style-type: none"> 1) Loose Speed pot connections 2) Min or Max trim pots improperly adjusted 3) Possible drive failure 	<ol style="list-style-type: none"> 1) Secure all connections 2) Refer to "Trim Pot Adjustment" 3) Contact ADC Returns for replacement (800) 633-0405
Motor rotates in wrong direction	Motor armature hooked up backwards	Reverse armature + and - leads
Motor stalls under a light load	Current Limit trim pot improperly adjusted	Refer to "Trim Pot Adjustment"