



RLL PROGRAMMING FOR COMMUNICATIONS

In This Chapter...

PLC-to-PLC Communications.....	4-2
How RLL is Used for Communications.....	4-2
Network Instructions	4-3
Addressing the Different Memory	4-6
Special Relays for Communications	4-11
Program with One Read Instruction.....	4-13
Example Program with One Write Instruction	4-15
Integrating Multiple Read and Write Instructions	4-17

PLC-to-PLC Communications

This chapter steps you through the development of a Relay Ladder Logic (RLL) program to enable one PLC to communicate with another PLC. For the experienced programmer of *Direct*LOGIC PLCs, the communication programs presented in this chapter will be simple to follow. If you have never programmed a *Direct*LOGIC PLC, you may want to refer to the *Direct*SOFT Programming Software User Manual and the User Manual for your PLC for additional information.



NOTE: The programs described in this chapter are not used for communication between a PC and a PLC. For PC-to-PLC communications, please see the product documentation for the PC software you are using. If you are using our DSData Server software, the manual you will need is the *KEPDirect for PLCs User Manual*.

How RLL is Used for Communications

*Direct*SOFT Programming Software provides Read and Write instructions (RX/WX) for PLC-to-PLC communication over a network. The Read and Write instructions are part of the ladder logic program running in the CPU of the initiating, or master, PLC. These instructions tell the initiating CPU to send a message over the Ethernet network to a responding, or slave, PLC. The ECOM module is the connecting point to the network for each PLC. The initiating PLC's Read or Write communication finds its destination by the Module ID of the responding PLC's ECOM module. See Chapter 2 and 3 for information about assigning Module IDs.

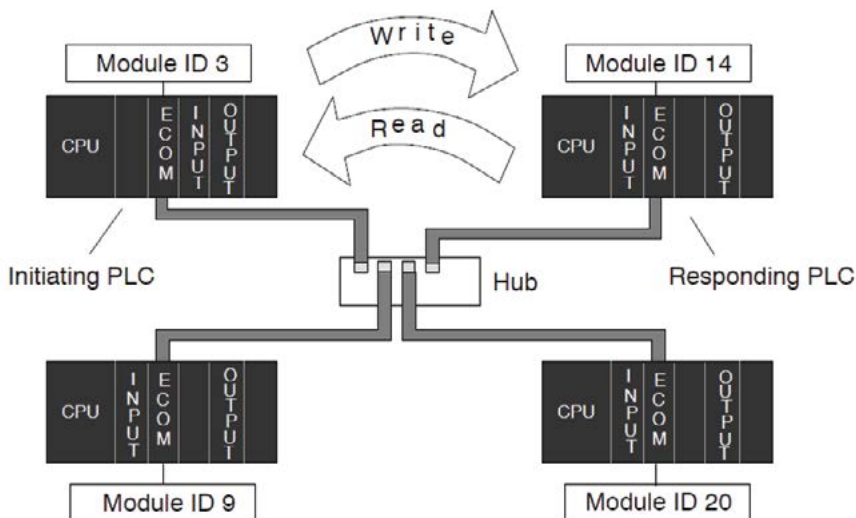

Network Instructions

Read (RX) and Write (WX) Instructions

The Read (RX) and Write (WX) instructions are used by the initiating PLC to Read a block of data from another PLC or Write a block of data to another PLC. To perform their functions, the RX and WX boxes must be preceded in the ladder logic program by two Load instructions and one Load Address instruction.

The Load and Load Address instructions load communication parameters into the accumulator and the first and second level of the accumulator stack. The RX or WX instruction takes these parameters from the stack and the accumulator and prepares the data to be sent over the network.

If you need to know more about the function of the accumulator and the accumulator stack, refer to the User Manual for your PLC.



NOTE: Please review intelligent instructions (IBOX) in Chapter 5 of the user manual for the PLC you are using, which simplify this and other functions.

Consider the following IBOX instructions: ECOM100, ECRX and ECWX. Building the Read (RX) or Write (WX) Routine

Building the Read (RX) and Write (WX) Routine

For network communications, you build the Read (RX) or Write (WX) instructions into a routine which requires the four instructions you see to the right. The function of each of these instructions is explained below or on the next page. They must be used in the sequence shown.

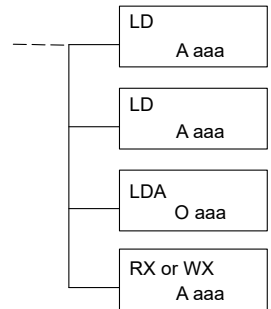

The First LD Instruction

The first Load (LD) instruction accepts either a constant or a variable. Use a “K” to designate the number as a constant. Use a “V” if you are entering the address of a register. The contents of that register perform the same function as the constant shown below. For example, you could use V2000 in place of K0114. If the contents of V2000 is the number “114,” the function would be the same. Using a variable allows changing parameters while the program is running. It is recommended, however, to use a constant when possible.

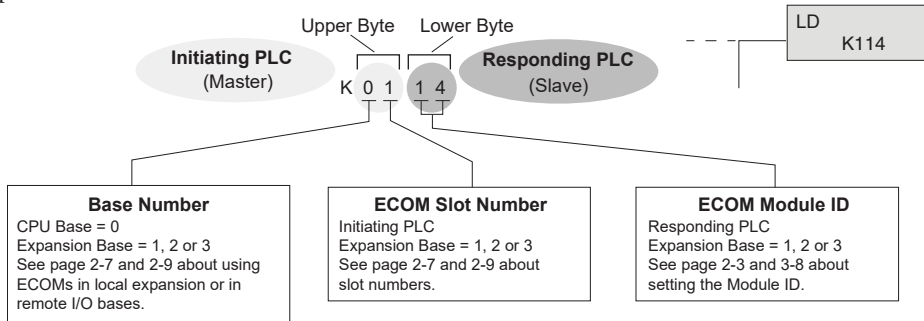

The Second LD Instruction

The second Load (LD) instruction determines the length of the data block to be transmitted during the Read or Write communication. This instruction will also accept two data types. Use a “K” to designate the number as a constant. Use a “V” if you are entering the address of a register.

For Word Memory data, you must use a multiple of two bytes between 2 and 128. For Bit Memory data, you can use any multiple of one byte between 1 and 128. For more information about addressing Word and Bit Memory, see page 4-6.

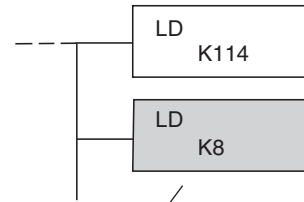
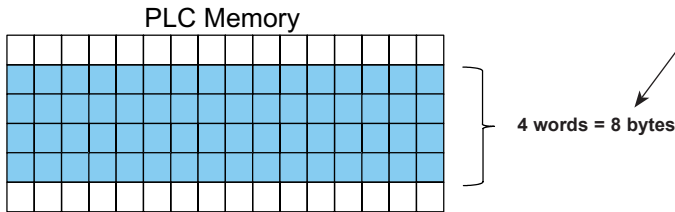

The LDA Instruction

The Load Address (LDA) instruction specifies the V-memory address of the beginning memory register in the initiating, or master, PLC. The data block to be transmitted will begin at this address and extend the number of bytes specified in the preceding LD instruction. The leading “O” indicates this is an octal number. Simply substitute the letter “O” for the “V” in the V-memory designation. For example, V40600 becomes O40600.

Read instructions copy the data block from the responding PLC memory into the initiating PLC memory.

Write instructions copy the data block from the initiating PLC memory into the responding PLC memory.

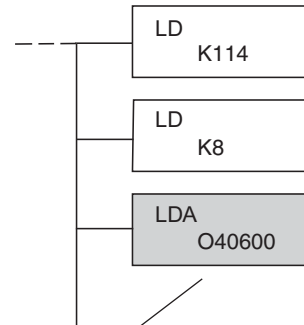
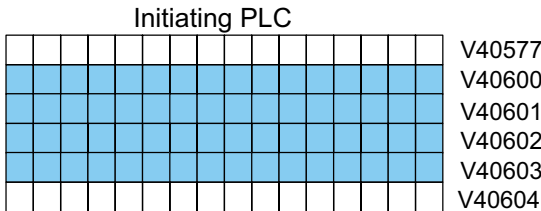

Read (RX) Instruction

The Read (RX) instruction specifies the memory location to be read from the responding PLC.

A block of data is read that begins at the specified memory location and extends the number of bytes specified in the second LD instruction.

In this example, the 8-byte block of data beginning at C100 and ending at C177 in the responding, or slave, PLC is read (copied) into the initiating PLC's memory beginning at V40600.

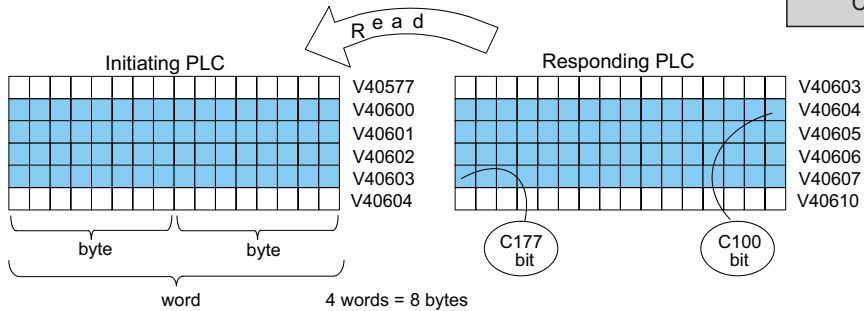
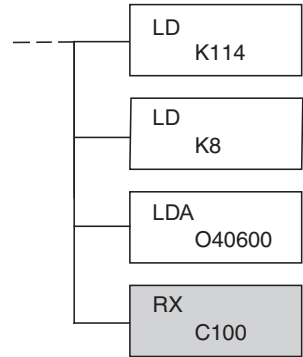

Write (WX) Instruction

The Write (WX) instruction specifies the memory location to be written to in the responding PLC.

A block of data is written that begins at the specified memory location and extends the number of bytes specified in the second LD instruction.

In the example, the 8-byte block of data beginning at V40600 and ending at V40603 in the initiating, or master, PLC is written (copied) into the memory of the responding PLC, beginning at C100 and ending at C177.

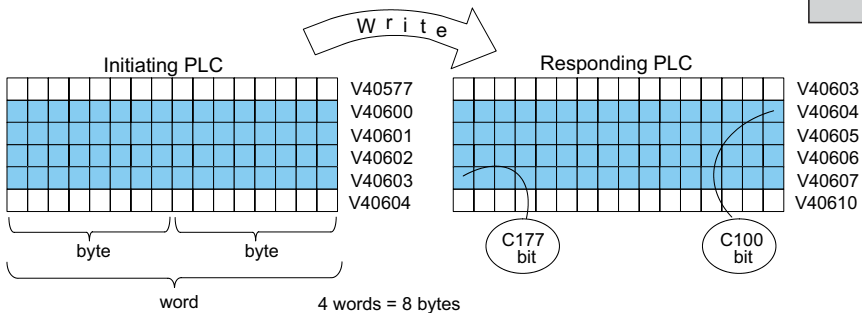
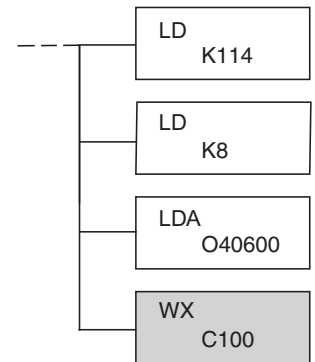

Addressing the Different Memory

Some data types are inherently 16 bits long, for example timer and counter current values. Other data types are 1 bit long, for example: discrete inputs and outputs. Word-length and bit-length data are mapped into Word Memory, also known as V-memory, which allows you to address any of the different memory types as 16-bit words.

Bit Memory

Bit memory can be addressed in Read and Write instructions by the name of the first bit of any byte. If your second LD instruction contains the constant K8, eight bytes will be transmitted. If you use C0 in your RX or WX instruction, you will transmit the eight bytes from C0 through C77.

Word Memory and Aliases

In the example below, V40600 is the V-memory designation for the sixteen bits from C0 through C17. Aliases are a convenient substitute for V-memory designations, and can be used interchangeably in Read and Write instructions. VC0 is the alias for V40600. Either nomenclature addresses the same 16 bits.

The alias is simply the name of the first bit in a group of sixteen bits, with V added as a prefix. For example, VC0 represents the 16 bits beginning with C0. Word Memory, Bit Memory and Aliases all use the octal numbering system.

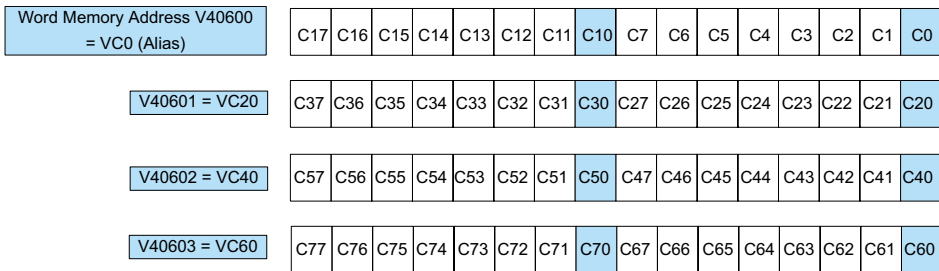

The following Write routines are all equivalent. *DirectSOFT* gives you the flexibility to identify the responding PLC's memory area in three different ways, as shown below.

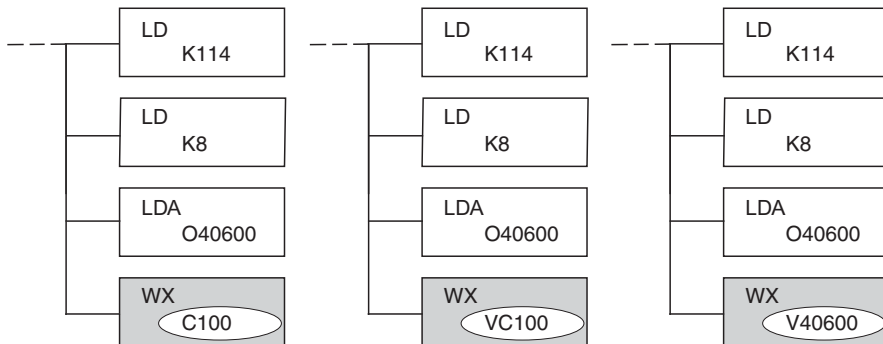

DirectSOFT is Flexible

You can address the different data types by any available convention shown in the tables that follow. The largest block of data that can be sent in a single Read or Write operation is 128 bytes. The smallest block of data is one byte for Bit Memory types and two bytes, or one word for Word Memory types. The octal numbering system is used for all addresses in these tables.

DL05 CPU

DL05 CPU			
Data Type	Bit Memory	Word Memory	Alias
Timer Current Values	None	V0 – V177	TA0 – TA177
Counter Current Values		V1000 – V1177	CTA0 – CTA177
User Data Words		V1200 – V7377	None
Input Points (See Note 1)	X0 – X377	V40400 – V40417	VX0 – VX360
Output Points (See Note 1)	Y0 – Y377	V40500 – V40517	VY0 – VY360
Control Relays	C0 – C777	V40600 – V40677	VCO – VC760
Special Relays	SP0 – SP777	V41200 – V41237	VSP0 – VSP760
Timer Status Bits	T0 – T177	V41100 – V41107	VT0 – VT160
Counter Status Bits	CT0 – CT177	V41140 – V41147	VCT0 – VCT160
Stages	S0 – S377	V41000 – V41017	VS0 – VS360

1 - The DL05 systems are limited to 8 discrete inputs and 6 discrete outputs with the present available hardware, but 256 point addresses exist.

DL06 CPU

DL06 CPU			
Data Type	Bit Memory	Word Memory	Alias
Timer Current Values	None	V0 – V377	TA0 – TA377
Counter Current Values		V1000 – V1177	CTA0 – CTA177
User Data Words		V400 – V677 V1200 – V7377 V10000–V17777	None
Input Points (See Note 1)	X0 – X777	V40400 – V40437	VX0 – VX760
Output Points (See Note 1)	Y0 – Y777	V40500 – V40537	VY0 – VY760
Control Relays	C0 – C1777	V40600 – V40677	VCO – VC1760
Special Relays	SP0 – SP777	V41200 – V41237	VSP0 – VSP760
Timer Status Bits	T0 – T377	V41100 – V41117	VT0 – VT160
Counter Status Bits	CT0 – CT177	V41140 – V41147	VCT0 – VCT160
Stages	S0 – S1777	V41000 – V41077	VS0 – VS1760
Remote I/O	GX0 – GX3777	V40000 – V40177	VGX0 – VGX3760
	GY0 – GY3777	V40200 – V40377	VGY0 – VGY3760

1 - The DL06 systems are limited to 20 discrete inputs and 16 discrete outputs with the present available hardware, but 512 point addresses exist.



NOTE: The D2-230 CPU does not support the ECOM modules.

D2-240 CPU

D2-240 CPU			
Data Type	Bit Memory	Word Memory	Alias
Timer Current Values	None	V0 – V177	TA0 – TA177
Counter Current Values		V1000 – V1177	CTA0 – CTA177
User Data Words		V2000 – V3777 V4000 – V4377	None
Input Points	X0 – X477	V40400 – V40423	VX0 – VX460
Output Points	Y0 – Y477	V40500 – V40523	VY0 – VY460
Control Relays	C0 – C377	V40600 – V40617	VCO – VC360
Special Relays	SP0 – SP137 SP540 – SP617	V41200 – V41205 V41226 – V41230	VSP0 – VSP120 VSP540 – VSP600
Timer Status Bits	T0 – T177	V41100 – V41107	VT0 – VT160
Counter Status Bits	CT0 – CT177	V41040 – V41147	VCT0 – VCT160
Stages	S0 – S377	V41000 – V41037	VS0 – VS760

D2-250-1 CPU

D2-250-1 CPU			
Data Type	Bit Memory	Word Memory	Alias
Timer Current Values	None	V0 – V377	TA0 – TA377
Counter Current Values		V1000 – V1377	CTA0 – CTA377
User Data Words		V1000 – V7377 V10000 – V17777	None
Input Points (See Note 1)	X0 – X777	V40400 – V40437	VX0 – VX760
Output Points (See Note 1)	Y0 – Y777	V40500 – V40537	VY0 – VY760
Control Relays	C0 – C1777	V40600 – V40677	VCO – VC1760
Special Relays	SP0 – SP777	V41200 – V41237	VSP0 – VSP1760
Timer Status Bits	T0 – T377	V41100 – V41147	VT0 – VT360
Counter Status Bits	CT0 – CT177	V41140 – V41077	VCT0 – VCT160
Stages	S0 – S1777	V41000 – V41077	VS0 – VS1760

D2-260/D2-262 CPU

D2-260/D2-262 CPU			
Data Type	Bit Memory	Word Memory	Alias
Timer Current Values	None	V0 – V377	TA0 – TA377
Counter Current Values		V1000 – V1377	CTA0 – CTA377
User Data Words		V400 – V777 V1400 – V7377 V10000 – V37777	None
Input Points	X0 – X1777	V40400 – V40477	VX0 – VX1760
Output Points	Y0 – Y1777	V40500 – V40577	VY0 – VY1760
Control Relays	C0 – C3777	V40600 – V40777	VCO – VC3760
Special Relays	SP0 – SP137 SP320 – SP717	V41200 – V41205 V41215 – V41234	VSP0 – VSP120 VSP320 – VSP700
Timer Status Bits	T0 – T377	V41100 – V41117	VT0 – VT360
Counter Status Bits	CT0 – CT377	V41000 – V41157	VCT0 – VCT360
Stages	S0 – S1777	V41000 – V41077	VSO – VS1760
Remote I/O	GX0 – GX3777 GY0 – GY3777	V40000 – V40177 V40200 – V40377	VGX0 – VGX3760 VGY0 – VGY3760

D4-430 CPU

D4-430 CPU			
Data Type	Bit Memory	Word Memory	Alias
Timer Current Values	None	V0 – V177	TA0 – TA377
Counter Current Values		V1000 – V1177	CTA0 – CTA377
User Data Words		V1400 – V7377	None
Input Points	X0 – X477	V40400 – V40423	VX0 – VX460
Output Points	Y0 – Y477	V40500 – V40577	VY0 – VY460
Control Relays	C0 – C737	V40600 – V40777	VCO – VC720
Special Relays	SP0 – SP137 SP320 – SP617	V41200 – V41205 V41215 – V41234	VSP0 – VSP120 VSP320 – VSP600
Timer Status Bits	T0 – T177	V41100 – V41117	VT0 – VT160
Counter Status Bits	CT0 – CT177	V41000 – V41157	VCT0 – VCT160
Stages	S0 – S577	V41000 – V41077	VSO – VS560
Remote I/O	GX0 – GX777 GY0 – GY777	V40000 – V40077 V40200 – V40377	VGX0 – VGX760 VGY0 – VGY760

D4-440 CPU

D4-440 CPU			
Data Type	Bit Memory	Word Memory	Alias
Timer Current Values	None	V0 – V377	TA0 – TA377
Counter Current Values		V1000 – V1177	CTA0 – CTA177
User Data Words		V1400 – V7377 V10000 – V17777	None
Input Points	X0 – X477	V40400 – V40423	VX0 – VX460
Output Points	Y0 – Y477	V40500 – V40523	VY0 – VY460
Control Relays	C0 – C1777	V40600 – V40677	VC0 – VC1760
Special Relays	SP0 – SP137 SP320 – SP717	V41200 – V41205 V41215 – V41234	VSP0 – VSP120 VSP320 – VSP700
Timer Status Bits	T0 – T377	V41100 – V41117	VT0 – VT360
Counter Status Bits	CT0 – CT177	V41140 – V411417	VCT0 – VCT160
Stages	S0 – S1777	V41000 – V41077	VS0 – VS1760
Remote I/O	GX0 – GX1777 GY0 – GY1777	V40000 – V40077 V40200 – V40377	VGX0 – VGX1760 VGY0 – VGY1760

D4-450/D4-454 CPU

D4-450/D4-454 CPU			
Data Type	Bit Memory	Word Memory	Alias
Timer Current Values	None	V0 – V377	TA0 – TA377
Counter Current Values		V1000 – V1377	CTA0 – CTA377
User Data Words		V1400 – V7377 V10000 – V37777	None
Input Points	X0 – X1777	V40400 – V40477	VX0 – VX1760
Output Points	Y0 – Y1777	V40500 – V40577	VY0 – VY1760
Control Relays	C0 – C3777	V40600 – V40777	VC0 – VC3790
Special Relays	SP0 – SP137 SP320 – SP717	V41200 – V41205 V41215 – V41234	VSP0 – VSP120 VSP320 – VSP700
Timer Status Bits	T0 – T377	V41100 – V41117	VT0 – VT360
Counter Status Bits	CT0 – CT377	V41140 – V41157	VCT0 – VCT360
Stages	S0 – S1777	V41000 – V41077	VS0 – VS1760
Remote I/O	GX0 – GX3777 GY0 – GY3777	V40000 – V40177 V40200 – V40377	VGX0 – VGX3760 VGY0 – VGY3760

Special Relays for Communications

The *Direct*LOGIC PLCs provide internal contacts (bits) for monitoring the status of communications. The internal contacts are called Special Relays (there are other Special Relays used for other purposes). There are two Special Relays for each slot in the base that will accept the ECOM module. The two relays perform the following functions:

- Communication Busy – This bit is on when the communication module is busy transmitting or receiving. You must use this bit, or relay contact, to prevent overwriting your Read or Write (RX/WX) instructions.
- Communication Error – This bit is on when an error occurred in the last RX or WX communication. This error automatically clears (the bit resets to zero) when another RX or WX instruction executes.

For example, Special Relays SP124 and SP125 correspond to an ECOM module in slot 3 of the PLC base.

The Special Relay SP125 is used in the example to energize the output Y50, indicating a communication error has occurred. This Special Relay must appear earlier in the program than your RX or WX instruction because it is turned off (reset to zero) when a subsequent Read or Write instruction is executed.

The Special Relay SP124 indicates the ECOM is busy. When SP124 is on, the normally closed contact opens to prevent executing another RX or WX instruction until the last one is completed. The appropriate busy bit must be used as a NC contact on every RX/WX instruction rung in the program.

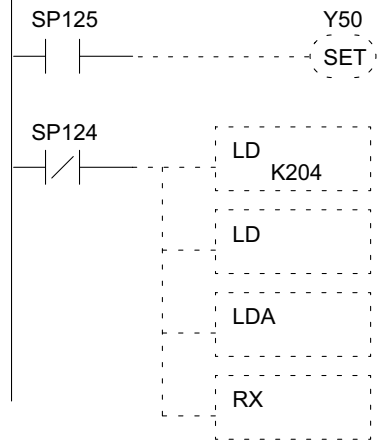

DL05 Special Purpose Communication Relays	
CPU Base	Option Slot
Communication Busy	SP120
Communication Error	SP121

DL06 Special Purpose Communication Relays				
CPU Base	Slot 1	Slot 2	Slot 3	Slot 4
Communication Busy	SP120	SP122	SP124	SP126
Communication Error	SP121	SP123	SP125	SP127

D2-240, D2-250-1, D2-260 and D2-262 Special Purpose Communication Relays							
CPU Base	Slot 1	Slot 2	Slot 3	Slot 4	Slot 5	Slot 6	Slot 7
Communication Busy	SP122	SP124	SP126	SP130	SP132	SP134	SP136
Communication Error	SP123	SP125	SP127	SP131	SP133	SP135	SP137

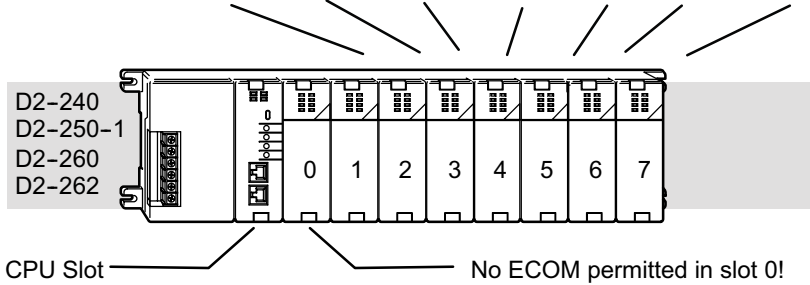

D4-430, D4-440 and D4-454 Special Purpose Communication Relays								
CPU Base	Slot 0	Slot 1	Slot 2	Slot 3	Slot 4	Slot 5	Slot 6	Slot 7
Communication Busy	SP120	SP122	SP124	SP126	SP130	SP132	SP134	SP136
Communication Error	SP121	SP123	SP125	SP127	SP131	SP133	SP135	SP137

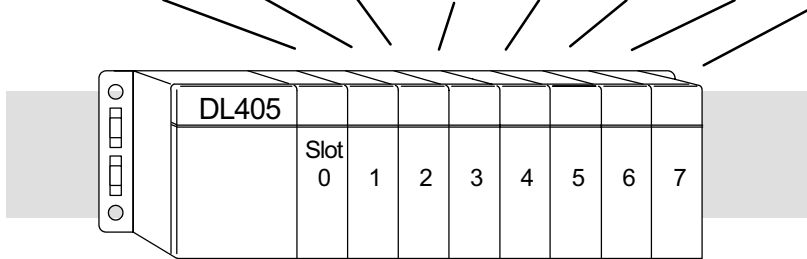

D4-430, D4-440 and D4-454 Special Purpose Communication Relays								
CPU Base	Slot 0	Slot 1	Slot 2	Slot 3	Slot 4	Slot 5	Slot 6	Slot 7
Communication Busy	SP120	SP122	SP124	SP126	SP130	SP132	SP134	SP136
Communication Error	SP121	SP123	SP125	SP127	SP131	SP133	SP135	SP137
Expansion Base 1								
Communication Busy	SP140	SP142	SP144	SP146	SP150	SP152	SP154	SP156
Communication Error	SP141	SP143	SP145	SP147	SP151	SP153	SP155	SP157
Expansion Base 2								
Communication Busy	SP160	SP162	SP164	SP166	SP170	SP172	SP174	SP176
Communication Error	SP161	SP163	SP165	SP167	SP171	SP173	SP175	SP177
Expansion Base 3								
Communication Busy	SP200	SP202	SP204	SP206	SP210	SP212	SP214	SP216
Communication Error	SP201	SP203	SP205	SP207	SP211	SP213	SP215	SP217

Program with One Read Instruction

The Ladder View screen below is the program development screen in *DirectSOFT* Programming Software. This four-rung program is explained in detail on page 4-14. This is a complete program although its function is very limited. There is also a two-rung program that runs in the responding PLC, and it is also explained on page 4-14.

Program for the Initiating PLC

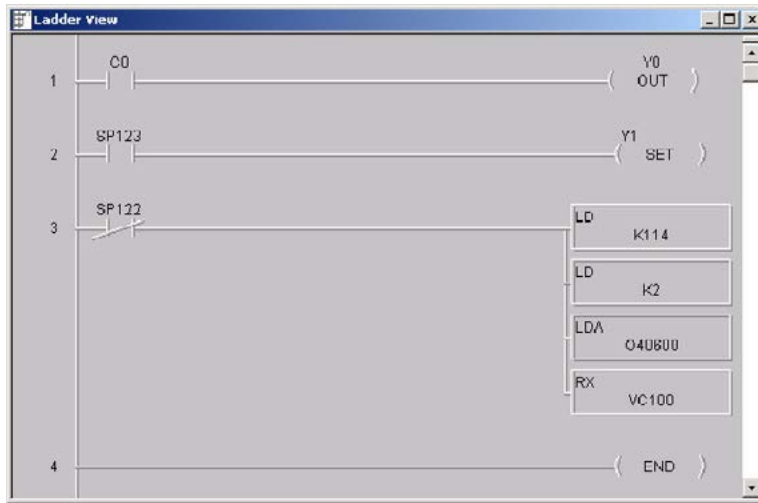

Program for the Responding PLC

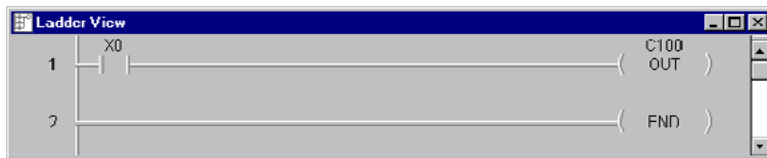

When the toggle switch input to the responding PLC is turned on (transitions from 0 to 1), the C0 bit in the initiating PLC transitions from 0 to 1. The program in the initiating PLC causes Y0 to turn on in response to the C0 bit.

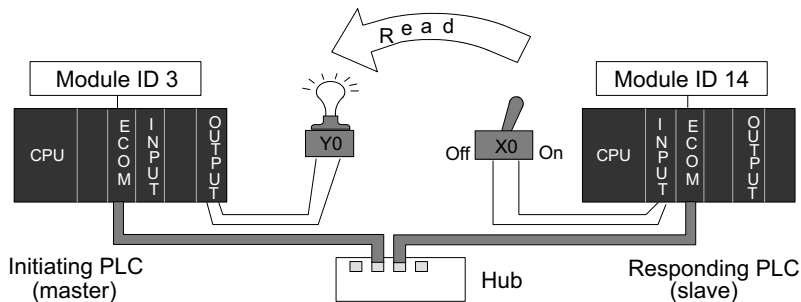

Rung 1

In our example, the normally open contact labeled C0 is an internal control relay. When C0 is on, discrete output Y0 is energized.



Rung 2

The second rung uses a Special Relay to identify a communication error. In the example, SP123 is on if a communication error is present for slot one. Use different Special Relays if your ECOM module is in a different slot (see page 4-11 and 4-12). We use SP123 to turn on an indicator light connected to a discrete output.



Rung 3

The Special Relay labeled SP122 is on when slot 1 is busy transmitting or receiving. The Read instruction may take longer than one PLC scan to complete. Use this Special Relay to prevent overwriting the previous Read instruction with each PLC scan.

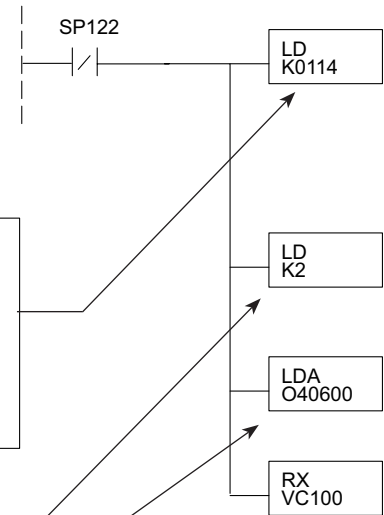
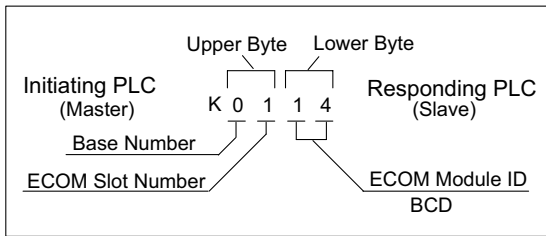

Number of bytes to be transferred. Max = 128 bytes

Beginning address in the initiating PLC, expressed as an octal number.

Beginning address in the responding PLC.

Rung 4

All *Direct*LOGIC PLCs use an END statement to identify the final rung of the main body of the program.



Program for the Responding PLC

This two-rung program resides in the responding PLC's CPU. Its function is simply to use the X0 contact to turn on the internal control relay, C100.

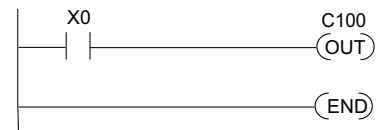

Example Program with One Write Instruction

The Ladder View screen below is the program development screen in *DirectSOFT* Programming Software. This four-rung program is explained in detail on page 4-16. This is a complete program although its function is very limited. There is also a two-rung program that runs in the responding PLC. It is also explained on page 4-16.

Program for the Initiating PLC

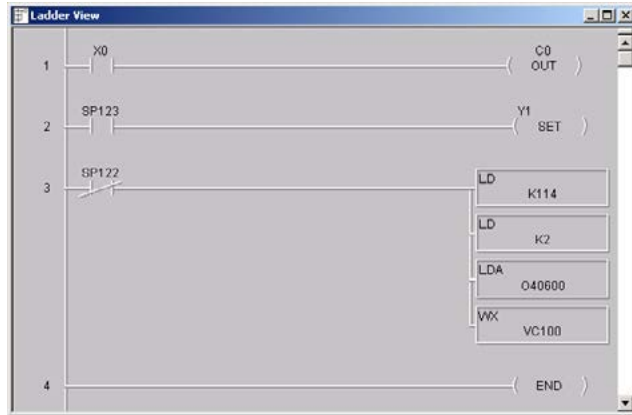

Program for the Responding PLC

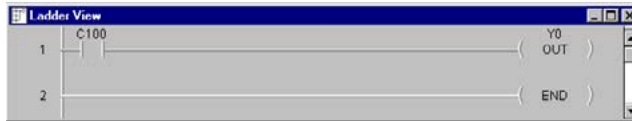

When the toggle switch input to the *initiating* PLC is turned on (transitions from 0 to 1), the C100 bit in the *responding* PLC also transitions from 0 to 1. The program in the responding PLC causes Y0 to turn on in response to the C100 bit.

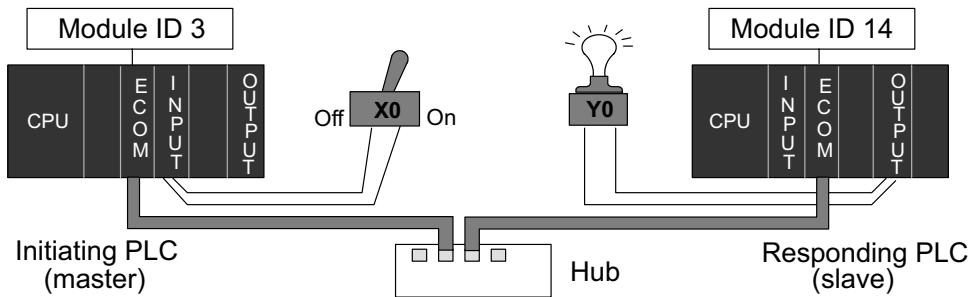

For the purpose of these example programs, both the initiating PLC and the responding PLC must be in RUN Mode.

Rung 1

In our example, the normally open contact labeled X0 is a toggle switch input to a discrete input module. When X0 is on, Control Relay C0 is energized.



Rung 2

The second rung uses a Special Relay to identify a communication error. In the example, SP123 is on if a communication error is present for slot one. Use different Special Relays if your ECOM module is in a different slot (see page 4-11 and 4-12). We use SP123 to turn on an indicator light connected to a discrete output.



Rung 3

The Special Relay labeled SP122 is on when slot 1 is busy transmitting or receiving. The Write instruction may take longer than one PLC scan to complete. Use this Special Relay to prevent overwriting the previous Write instruction with each PLC scan.

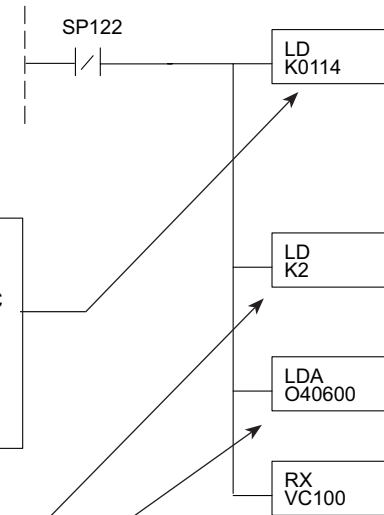
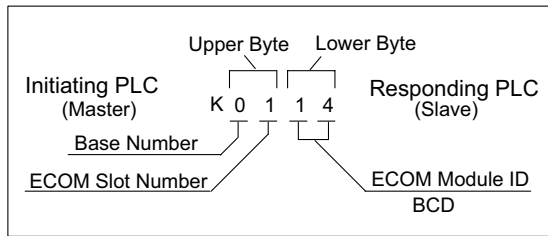

Number of bytes to be transferred. Max = 128 bytes

Beginning address in the initiating PLC, expressed as an octal number.

Beginning address in the responding PLC.

Rung 4

All *Direct*LOGIC PLCs use an END statement to identify the final rung of the main body of the program.

Program for the Responding PLC

This two-rung program resides in the responding PLC's CPU. Its function is simply to take the C100 contact and convert it to a real output, Y0.

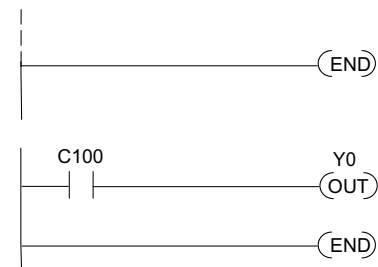

Integrating Multiple Read and Write Instructions

Multiple Read and Write instructions require interlocks for sequencing because only one RX/WX instruction can be processed per CPU scan. Using interlocks, one RX/WX instruction is processed in each scan until all RX/WX instructions have been executed. After the last instruction, the sequence then begins again at the first RX/WX instruction.

Without interlocks, the RX/WX instructions would be executed in an unpredictable order, and some might be executed many times before others are executed once. The interlocks serve to open (disconnect) the ladder circuits for all Read and Write instructions except the one that should be processed on the current CPU scan.



Note: To simplify programming when using an ECOM100 module, consider using IBOX instructions ECOM100, ECRX, ECVX. These instructions handle the interlocking for the user. Please reference Chapter 5 of the user manual for the PLC you are using.

We show two methods of creating the interlocks necessary for sequencing multiple Read and Write instructions:

- Sequenced Internal Control Relays
- Shift Register

We will step you through the development of the interlocks using both methods. The two examples shown perform the same function. Only the interlocks are different.



NOTE: To fully understand the material in this section, you will first need to understand the Example Programs on pages 4-13 and 4-15, as well as the material in the Network Instructions section, beginning on page 4-3.

The following program segment sequences through three RX/WX instructions (two Write instructions and one Read instruction). You can develop your own program incorporating either of the two interlocking control strategies and expanding the number of interlocks to accommodate the number of RX/WX instructions in your program.

Interlocking Relays

It is easy to see the function of the interlocking relays if we construct a truth table first.

Across the top of the truth table we show internal control relays that we are considering using for our sequencing strategy. We have used C50 through C52 for our chart, but any contacts that are not used for other purposes in your program will work just as well.

Down the left side of the chart, we list the number of RX/WX instructions we may want to use in our RLL program.

The three contacts in this truth table will accommodate as many as eight Read or Write instructions. Our program only has three RX/WX instructions so we only need to use two contacts (see why on page 4-18). We will use C50 and C51. One additional contact (C53) would give us 32 combinations since the number of combinations expands as the power of 2.

Truth Table	C52	C51	C50
First RX/WX	0	0	0
Second RX/WX	0	0	1
Third RX/WX	0	1	0
Fourth RX/WX	0	1	1
Fifth RX/WX	1	0	0
Sixth RX/WX	1	0	1
Seventh RX/WX	1	1	0
Eighth RX/WX	1	1	1

Our three RX/WX instructions can be sequenced by the two contacts C50 and C51. Two contacts provide four different binary states:

- Both off
- C50 on and C51 off
- C50 off and C51 on
- Both on

Truth Table	C52	C51	C50
First RX/WX	0	0	0
Second RX/WX	0	0	1
Third RX/WX	0	1	0
Fourth RX/WX	0	1	1
Fifth RX/WX	1	0	0
Sixth RX/WX	1	0	1
Seventh RX/WX	1	1	0
Eighth RX/WX	1	1	1

We only need to use three of the four binary states (circled) since we only have three RX/WX instructions to sequence.

First RX/WX Instruction

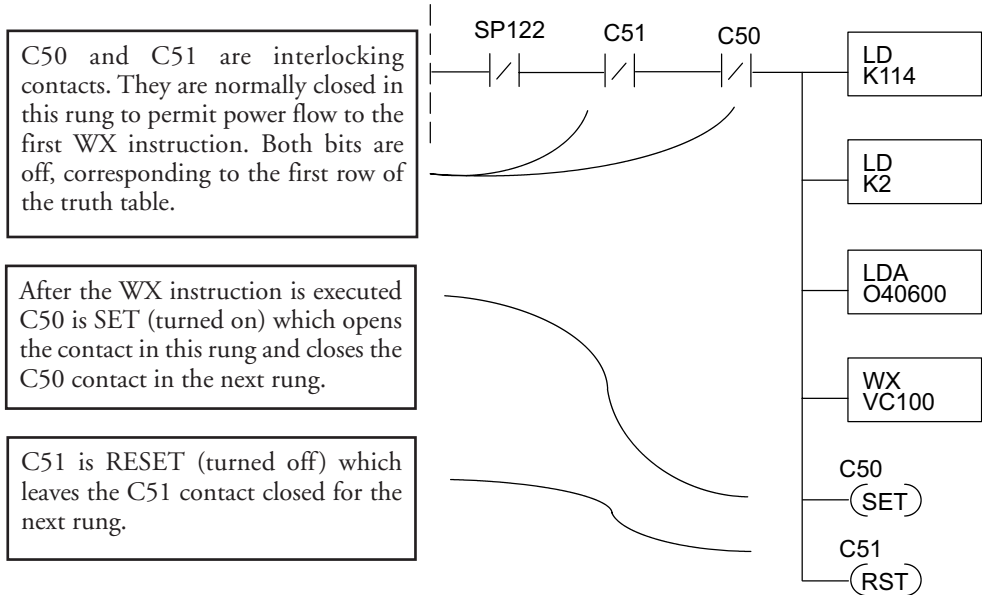

Second RX/WX Instruction

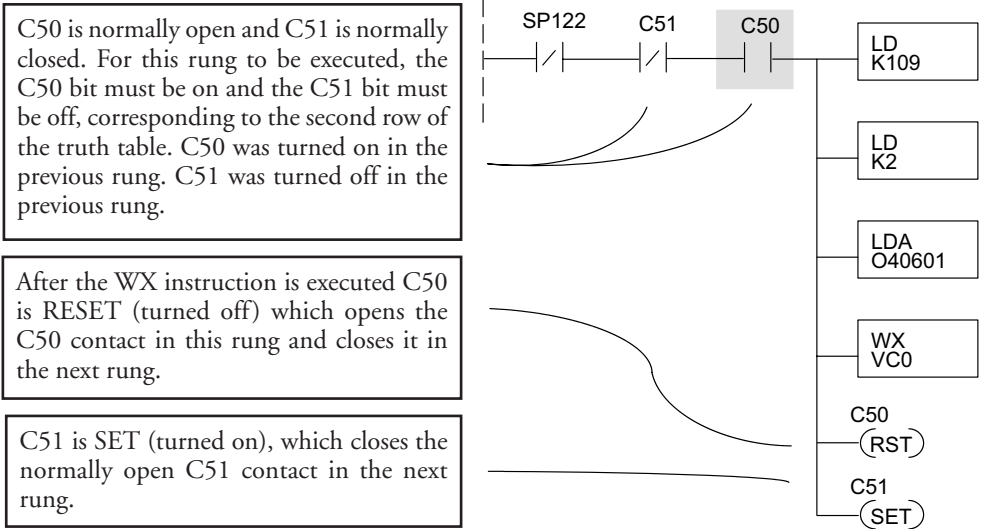

Third RX/WX Instruction

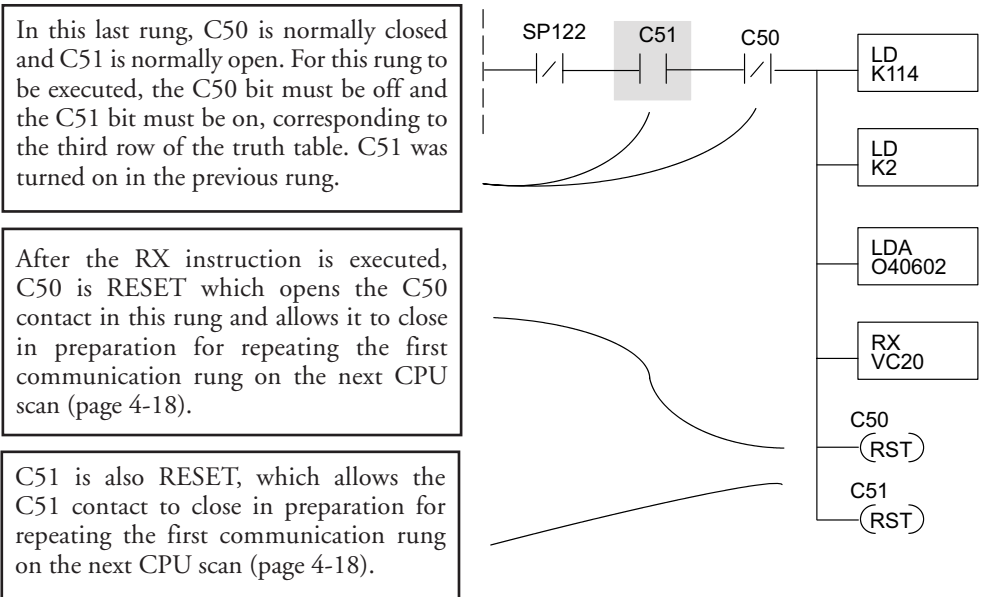

Returning to the First RX/WX Instruction

At the end of the third RX/WX instruction, we cycle back to the top row of the truth table on page 4-18. Both C50 and C51 are off, and the next CPU scan executes the first RX/WX instruction.

Shift Register

The Shift Register can be used for creating interlocks, as an alternative to using control relays. For a complete explanation of the function of the Shift Register, see the User Manual for your PLC. If you have more than a few RX/WX instructions, using control relays can become cumbersome. The Shift Register allows a single contact to be used in each communication rung as an interlock.

The data input to the Shift Register (SR) is Special Relay SP1. SP1 is the always-on bit. Combined with a normally closed contact it sends zeros to the Shift Register data input. The clock input to the Shift Register is SP122, the communication busy bit. Each time one of the RX/WX instructions executes, the Shift Register moves the set bit over one place. C63 is used in this example to reset the Shift Register to all zeros.

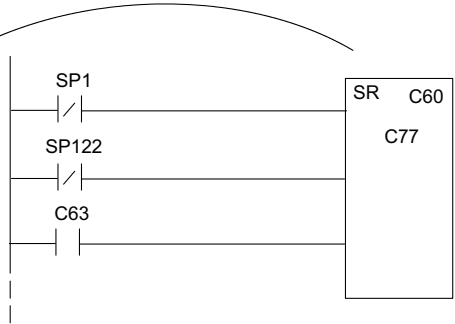

C77	C76	C75	C74	C73	C72	C71	C70	C67	C66	C65	C64	C63	C62	C61	C60
-----	-----	-----	-----	-----	-----	-----	-----	-----	-----	-----	-----	-----	-----	-----	-----

Shift Register after first scan.

C77	C76	C75	C74	C73	C72	C71	C70	C67	C66	C65	C64	C63	C62	C61	C60
-----	-----	-----	-----	-----	-----	-----	-----	-----	-----	-----	-----	-----	-----	-----	-----

Shift Register after second scan.

C77	C76	C75	C74	C73	C72	C71	C70	C67	C66	C65	C64	C63	C62	C61	C60
-----	-----	-----	-----	-----	-----	-----	-----	-----	-----	-----	-----	-----	-----	-----	-----

Shift Register after first RX/WX.

C77	C76	C75	C74	C73	C72	C71	C70	C67	C66	C65	C64	C63	C62	C61	C60
-----	-----	-----	-----	-----	-----	-----	-----	-----	-----	-----	-----	-----	-----	-----	-----

Shift Register after second RX/WX.

C77	C76	C75	C74	C73	C72	C71	C70	C67	C66	C65	C64	C63	C62	C61	C60
-----	-----	-----	-----	-----	-----	-----	-----	-----	-----	-----	-----	-----	-----	-----	-----

Shift Register after third RX/WX.

C77	C76	C75	C74	C73	C72	C71	C70	C67	C66	C65	C64	C63	C62	C61	C60
-----	-----	-----	-----	-----	-----	-----	-----	-----	-----	-----	-----	-----	-----	-----	-----

Shift Register after third RX/WX plus one scan.

Store If Equal

The Store If Equal instruction detects when the Shift Register is reset to zeros. When that condition is true the C60 bit is SET by this rung. The C60 bit becomes the high bit shifted by the Shift Register until each RX/WX instruction is executed in turn.



First RX/WX Instruction

C60 is the interlocking contact. It is turned on by the Store If Equal rung preceding this one.

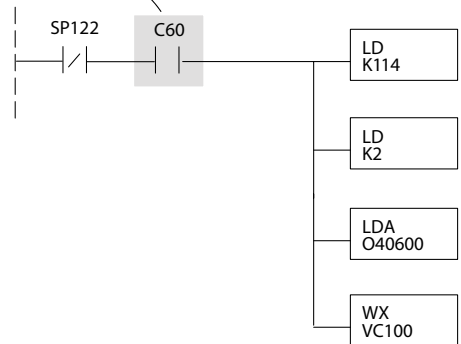

Second RX/WX Instruction

C61 is the interlocking contact. It is turned on by the sequencing steps of the Shift Register in a preceding rung.

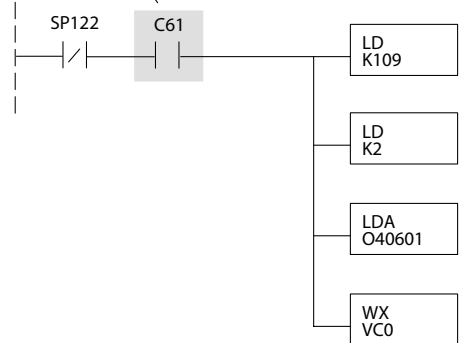

Third RX/WX Instruction

C62 is the interlocking contact. It is turned on by the sequencing steps of the Shift Register in a preceding rung.

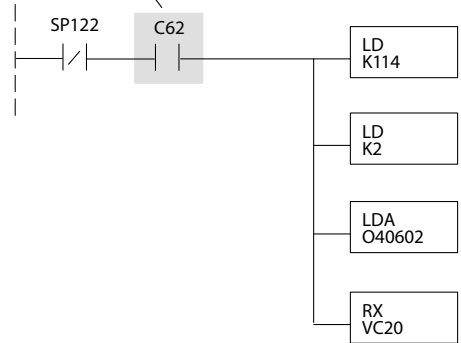

After this rung is executed, the Shift Register shifts the high bit from C62 to C63 on the next CPU scan. C63 resets the Shift Register to zeros, the Store If Equal sets the C60 bit, and the CPU executes the first RX/WX instruction.