

SPECIFICATIONS: SPECIALTY MODULES



In This Chapter...

Specialty Modules Overview	7-2
Specialty Modules	7-2
H2-CTRIO(2)	7-4
H2-CTRIO(2) Overview.....	7-4
H2-CTRIO(2) Specifications	7-6
H2-CTRIO(2) LED Indicators	7-7
H2-CTRIO(2) Jumper Setup	7-8
Wiring Information.....	7-9
PNP Field Device (source).....	7-9
NPN Field Device (sink).....	7-9
H2-CTRIO(2) Input Wiring Examples	7-10
TTL Quadrature Encoder Field Wiring.....	7-10
TTL Input Wiring Example	7-10
Quadrature Encoder Wiring Example	7-11
NPN Open Collector Device.....	7-11
PNP Open Collector Device.....	7-11
H2-CTRIO(2) Output Wiring Examples	7-12
H2-ECOM100	7-13
H2-ECOM100 Overview	7-13
H2-ECOM100 Specifications.....	7-13
H2-ECOM100 LED Indicators	7-14
H2-ECOM100 Network Identifiers	7-14
H2-ECOM100 Network Layouts	7-17
H2-ECOM100 Network Cabling	7-18
H2-ERM(100)/ H2-EBC100	7-21
H2-ERM(100) Overview.....	7-21
H2-ERM(100) Specifications	7-21

Table of Contents

H2-ERM(100) LED Indicators	7-22
H2-EBC100 Overview	7-22
H2-EBC100 Specifications.....	7-22
H2-EBC100 LED Indicators	7-23
H2-ERM(100)/H2-EBC100 Network Identifiers.....	7-23
H2-ERM(100)/H2-EBC100 Network Layouts	7-26
H2-ERM(100)/H2-EBC100 Network Cabling.....	7-27
H2-SERIO(-4)	7-29
H2-SERIO(-4) Overview	7-29
H2-SERIO(-4) Specifications.....	7-31
H2-SERIO(-4) Wiring: RS-232.....	7-31
H2-SERIO-4 Wiring: RS-422/485.....	7-32
F2-08SIM, Input Simulator	7-33
F2-08SIM Specifications	7-33

Specialty Modules Overview

There are several Specialty modules available for use in local and remote I/O bases. These modules are listed in the tables below and their specifications are found in this chapter. Each specialty module is identified with a White bar across the front panel as seen below. The module's front panel is also equipped with LED status indicators. Depending on the module, these indicators can show the network health, module health, I/O status or mode of operation the module is currently in.

Specialty Modules

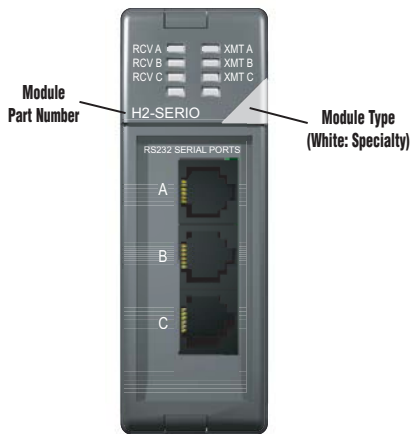

Specialty Modules		
Part Number	Description	See Page
H2-CTRIO2*	High Speed Counter Interface Module	7-5
H2-ECOM100	Ethernet Communications Module	7-14
H2-ERM100* H2-EBC100	Ethernet Remote Master Module Ethernet Base Controller	7-22
H2-SERIO(-4)	Serial I/O Module	7-30
F2-08SIM	8-point Input Simulator Module	7-34

* The H2-CTRIO and H2-ERM modules are discontinued.



NOTE: The H2-CTRIO module has been discontinued. The H2-CTRIO2 is the replacement module.

Specialty Modules Overview - continued

Specialty Modules Supported			
Part Number	Description	Part Number	Description
<i>H2-CTRIO*</i>	High Speed Counter Interface Module	<i>H2-EBC*</i>	10 Base-T Ethernet Base Controller
<i>H2-CTRIO2</i>	High Speed Counter Interface Module	<i>H2-EBC100</i>	100 Base-T Ethernet Base Controller
<i>H2-ECOM*</i>	10 Base-T Ethernet Communication Module	<i>H2-EBC-F</i>	10 Base-FL Ethernet Base Controller
<i>H2-ECOM100</i>	100 Base-T Ethernet Communication Module	<i>H2-SERIO</i>	Serial I/O Module
<i>H2-ECOM-F</i>	10 Base-FL Ethernet Communication Module	<i>H2-SERIO-4</i>	Serial I/O Module
<i>H2-ERM(100)</i>	10/100 Base-T Ethernet Remote Master Module	<i>F2-08SIM</i>	8-point Input Simulator Module
<i>H2-ERM-F</i>	10 Base-FL Ethernet Remote Master Module		

* The H2-CTRIO, H2-ECOM and H2-EBC modules are discontinued but are still compatible with the new Do-more H2 Series PLC.

Specialty Modules NOT Supported			
Part Number	Description	Part Number	Description
<i>D2-CTRINT</i>	Counter Interface Module	<i>D2-EM</i>	Expansion Base I/F Module
<i>D2-DCM</i>	Data Communication Module	<i>H2-PBC*</i>	Profibus Base Controller
<i>D2-RMSM*</i>	Remote I/O Master Module	<i>F2-DEVNETS-1</i>	DeviceNet Base Controller
<i>D2-CM</i>	Expansion Base Controller	<i>F2-SDS-1</i>	Smart Distributed System Base Controller
<i>F2-CP128</i>	CoProcessor Module	<i>DV-1000</i>	DirectVIEW 1000 Timer/Counter access unit
<i>D2-HPP</i>	Handheld Programmer		

* The D2-RMSM and H2-PBC modules are discontinued.

H2-CTRIO(2)

H2-CTRIO(2) Overview

The H2-CTRIO(2) Counter I/O (CTRIO) module is designed to accept high-speed pulse input signals for counting or timing applications. This module also provides high-speed pulse output signals for servo/stepper motor control, monitoring and alarming as well as other discrete control functions.

The H2-CTRIO(2) module offers greater flexibility for applications which call for precise counting or timing based on input events or for high-speed control output applications. They can also be used for applications that call for a combination of both high-speed input and high-speed output control functions.

The H2-CTRIO(2) module has its own internal microprocessor and operates asynchronously with respect to the CPU. Therefore, the response time of the on-board outputs is based on the module scan time, not the CPU's scan time (unless the CPU is controlling the outputs directly).

H2-CTRIO2 Terminal Block Layout



NOTE: The H2-CTRIO module has been discontinued. Please use the H2-CTRIO2 modules as the replacement. H2-CTRIO and H2-CTRIO modules have the same terminal block layout.

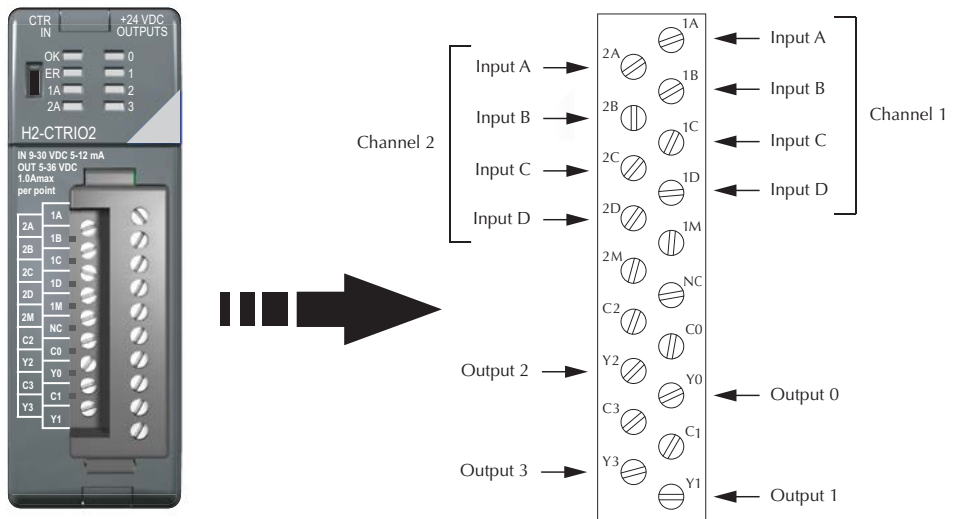

H2-CTRIO(2) Configuration

The module configuration of the H2-CTRIO2 is done from within the Edit CTRIO/CTRIO2 Configuration window seen below. The Configure I/O..., Input Filters..., Discrete Tables... and Pulse Profiles... buttons in the left hand column will allow you to configure the input and output functions of the selected module. Refer to the Do-more Designer Help File for more information on configuration options.

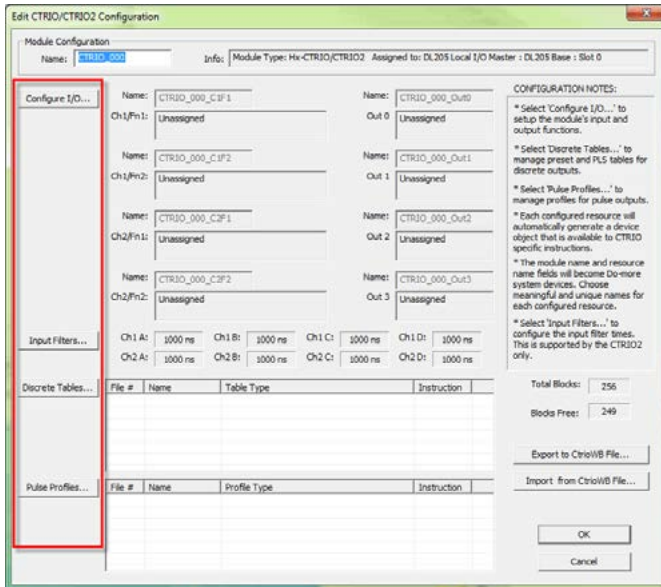

The above window can be accessed once the H2-CTRIO2 module is added to the I/O configuration either manually or automatically. See the Verify Hardware Configuration section of the Getting Started chapter for more information on setting up the I/O configuration. With the module added, select the Module Configuration(s) entry from the System Configuration page. Then choose the desired module and select Edit Config.

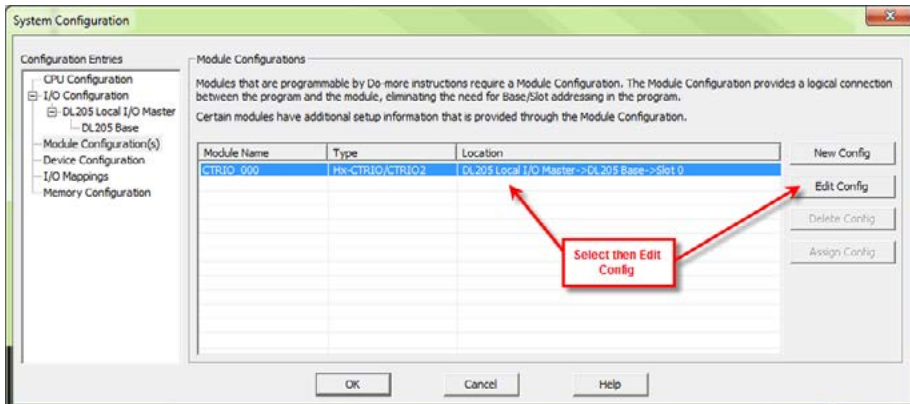

H2-CTRIO(2) Specifications

General Specifications		
Specifications	H2-CTRIO*	H2-CTRIO2
Discrete I/O Points Used	None (I/O map directly in H2-DM1/E data structure)	
Base Power Required	400mA Max	275mA Max
Isolation	2500V I/O to Logic, 1000V among Input Channels and All Outputs	1500V I/O to Logic, 1000V among Input Channels and All Outputs

Input Specifications		
Specifications	H2-CTRIO*	H2-CTRIO2
Inputs	8 pts sink/source	
Maximum Input Frequency	100kHz	250kHz
Minimum Pulse Width	5µsec	0.5 µs
Input Voltage Range	9–30 VDC	9–30 VDC
Maximum Voltage	30VDC	
Input Voltage Protection	Zener Clamped at 33VDC	
Rated Input Current	8mA typical 12mA maximum	
Minimum ON Voltage	9.0 VDC	
Maximum OFF Voltage	2.0 VDC	
Minimum ON Current	5.0 mA	
Maximum OFF Current	2.0 mA	
OFF to ON Response	less than 3µs	less than 0.5 µs
ON to OFF Response	less than 3µs	less than 0.5 µs

Output Specifications		
Specifications	H2-CTRIO*	H2-CTRIO2
Outputs	4 pts (sink/source), independently isolated	
Pulse Outputs	2 channels, 20Hz to 25kHz Pulse/Direction or CW/CCW	2 channels, 20Hz to 250kHz Pulse/Direction or CW/CCW
Minimum Pulse Width	5µs	0.5 µs
Output Voltage Range	5–36 VDC	
Maximum Output Voltage	36VDC	
Maximum Load Current	1.0 A	1.0 A at 23°C 0.5 A at 60°C
Maximum Leakage Current	100µA	
Inrush Current	5.0 A for 20ms	2.0 A for 10ms
ON State V Drop	0.3 VDC or less	0.45 VDC or less
Overcurrent Protection	Yes	
OFF to ON Response	less than 3µs	less than 1µs
ON to OFF Response	less than 3µs	less than 1µs

* The H2-CTRIO module has been discontinued. The H2-CTRIO2 is the replacement.

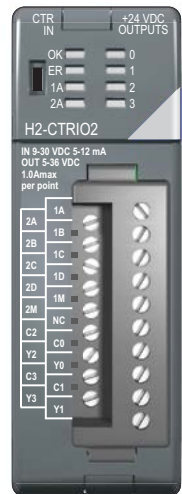
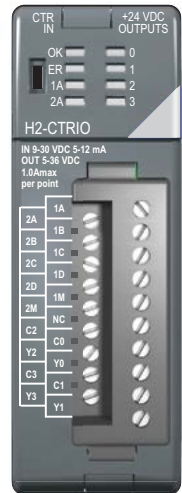

H2-CTRIO(2) LED Indicators

H2-CTRIO(2) LED Descriptions

OK	Module OK
ER	User Program Error
1A	Channel 1 Status
2A	Channel 2 Status
0-3	Output Status

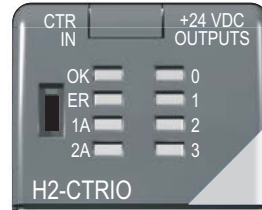

H2-CTRIO(2) LED Diagnostic Definitions

LED OK	LED ER	Description
Blinking	Blinking	Boot Mode - Used for Field OS Upgrades
Blinking	OFF	Program Mode
OFF	Blinking	Module Self-Diagnostic Failure (Blinks may be coded by counts)
OFF	ON	Module Error Due to Watchdog Timeout
OFF	OFF	No Power to Module
ON	OFF	All is well - RUN Mode
ON	ON	Hardware Failure (H2-CTRIO) Not Used (H2-CTRIO2)

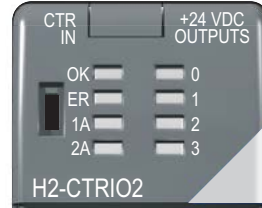

H2-CTRIO(2) LED Diagnostic Definition

1A/2A	
Blinking 7 times per second	Input is configured as Counter and is changing
Following state of input	Input is not configured as counter
0-3	
Follow actual output state: ON = output is passing current	

H2-CTRIO(2) Jumper Setup

Jumpers are provided to connect input commons or outputs/output commons. Use of these jumpers is not necessary to set up the CTRIO(2) module. The jumpers are provided solely for convenience in wiring.



NOTE: The location of the jumper board and pin assignments are different between the CTRIO and CTRIO2.

H2-CTRIO(2) Jumper Functions		
H2-CTRIO	H2-CTRIO2	Function
	1M-2M	Install jumper to internally connect the input commons 1M and 2M in order to reduce wiring if appropriate.
	Y0-Y1	Install jumper(s) to internally connect Y0 to other Y terminals in order to reduce wiring if appropriate. Connect wire at Y0.
	Y0-Y2	
	Y0-Y3	
C0-C1		Install jumper(s) to internally connect C0 to other C terminals in order to reduce wiring if appropriate. Connect wire at C0.
C0-C2		
C0-C3		
	C3-C0	Install jumper(s) to internally connect C3 to other C terminals in order to reduce wiring if appropriate. Connect wire at C3.
	C3-C1	
	C3-C2	

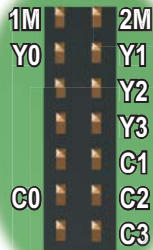

H2-CTRIO

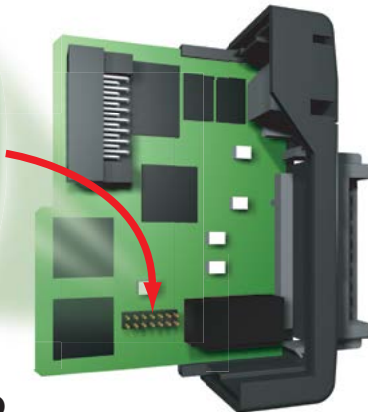

H2-CTRIO2

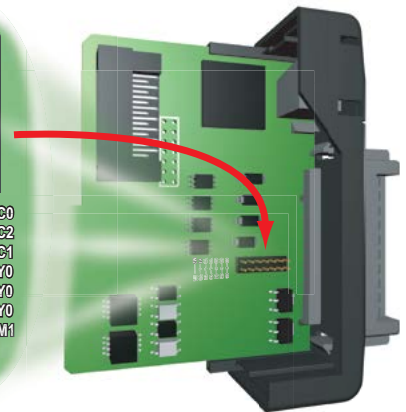

Wiring Information

The H2-CTRIO(2) module has two independent input channels, each consisting of four optically isolated input points (pts. 1A-1D on common 1M and pts. 2A-2D on common 2M). The inputs can be wired to either sink or source current.

The module has four optically isolated output points (Y0-Y3 with isolated commons C0-C3, respectively) that can be wired to either sink or source current. Remember that the internal jumpers can be used to connect the input commons or output commons together.

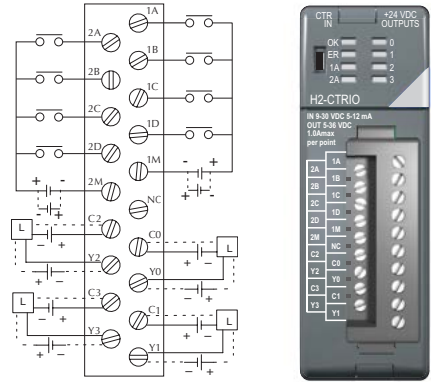

NOTE: Field device wiring must be compatible with the module configuration configured in Do-more Designer

DC type field devices are configured to either sink or source current. This affects the wiring of the device to the CTRIO module as seen below.

PNP Field Device (source)

NPN Field Device (sink)

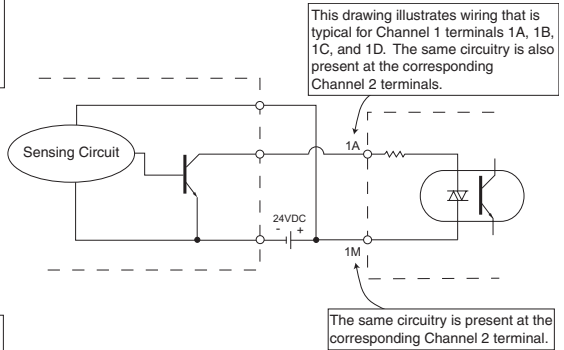
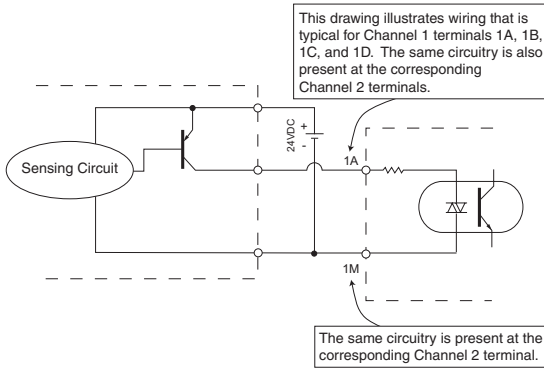

H2-CTRIO(2) Wiring Considerations

When wiring CTRIO(2) modules, please consider the following:

- Keep encoder input wiring as short as possible
- Route wiring to avoid any runs parallel to noisy cables.
- Route wiring to avoid the proximity of noisy devices.
- Use shielded, twisted pair cables, such as:

Suggested Cabling		
Type of Cable	Supplier/Part Number	Supplier/Part Number
3 pair, twisted, overall shield	AutomationDirect/L19853-XXXX	Belden/8103
1 pair, twisted, overall shield	AutomationDirect/L19827-XXXX	Belden/9841

H2-CTRIO(2) Input Wiring Examples

TTL Quadrature Encoder Field Wiring

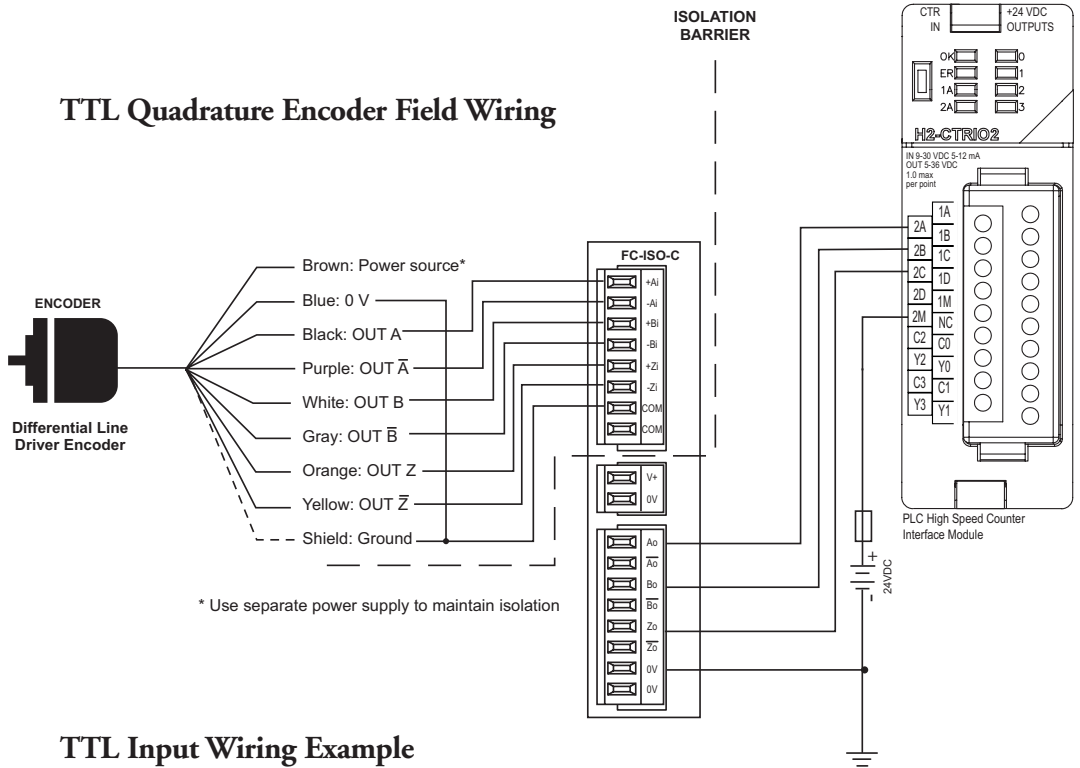

TTL Input Wiring Example

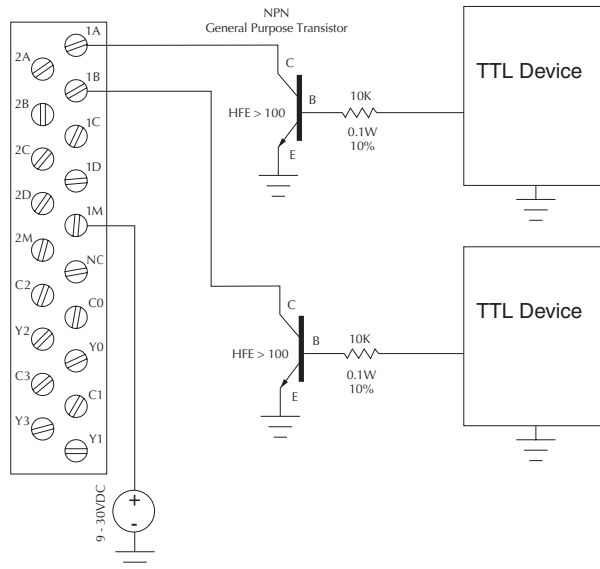

Quadrature Encoder Wiring Example

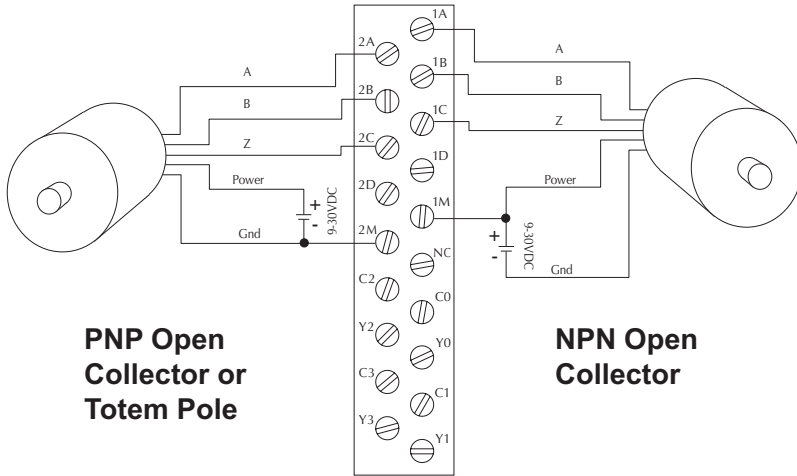

PNP Open Collector or Totem Pole

NPN Open Collector

NPN Open Collector Device

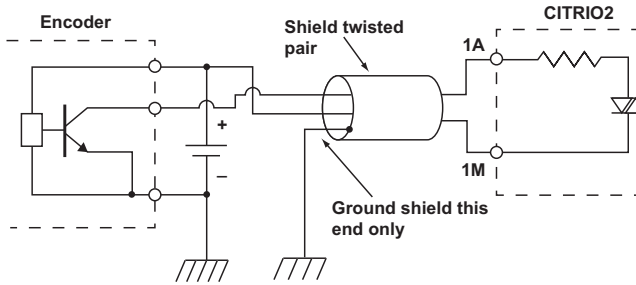

PNP Open Collector Device

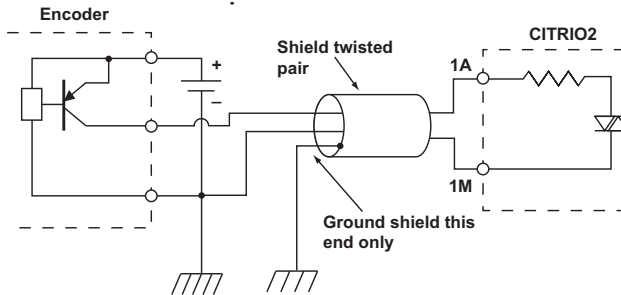

H2-CTRIO(2) Output Wiring Examples

The four outputs are individually isolated so each output can be used to break the high or the low side of a DC load separately

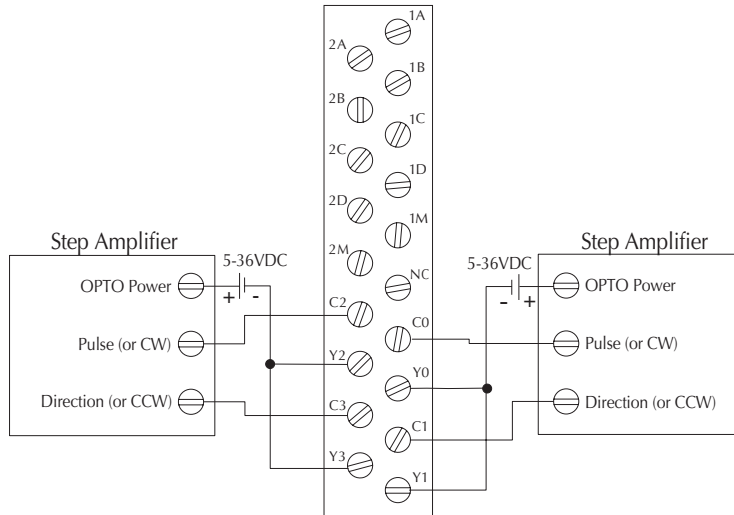
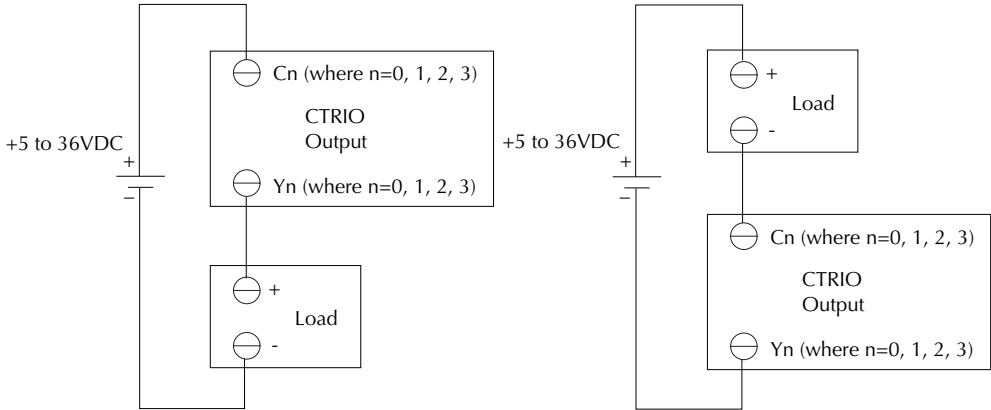

WARNING: The above example assumes that the Step Amplifier interface is made up of optocoupler LEDs (common anodes at the “OPTO Power” terminal) with internal current limiting resistors. This is a standard method, but you must consult your step amplifier documentation to ensure that this method is applicable.

H2-ECOM100

H2-ECOM100 Overview

The H2-ECOM100 Ethernet Communication (ECOM) module provides high-speed Ethernet connections for the Do-more PLC. These modules are easy to set up and install on 10/100BaseT (twisted pair, copper wire) Ethernet networks.

LEDs on the face of each module give vital information about the status of the module and the communications link. The 10/100BaseT modules use standard RJ45 modular connectors.

You can use the ECOM modules to share data between two or more Do-more PLCs or between Do-more PLCs and personal computers. The H2-ECOM100 only supports DLRX and DLWX instructions in DMD.

You can use a personal computer equipped with a 10/100BaseT network adapter card and NetEdit3 software to configure the ECOM module over the network. Once configured, the H2-ECOM100 module allows you to program your Do-more PLC over the Ethernet network using the Do-more Designer programming software. The NetEdit3 utility installs with the Do-more Designer software and can be very useful for troubleshooting certain communication problems.



NOTE: We recommend using a dedicated network for your PLC control applications.

H2-ECOM100 Specifications

H2-ECOM100 Ethernet Communications Module	
Specifications	H2-ECOM100
Communications	10/100Base-T Ethernet
Data Transfer Rate	100 Mbps max.
Link Distance	100m (328ft)
Ethernet Port	RJ45
Ethernet Protocols	TCP/IP, IPX, Modbus TCP, DHCP, HTML configuration
Power Consumption	300mA @ 5VDC



H2-ECOM100 LED Indicators

H2-ECOM100 LED Descriptions		
Indicator	Status	Description
STATUS	ON (Green)	Module is powered up and functional
	OFF	Module powerup failed
LINKGD	ON (Green)	Properly connected to network
	OFF	Not connected to network or incorrect configuration
ACTIVE	ON or FLASHING (Red)	Active Network Data
	OFF	Network Idle
ERROR	ON or FLASHING (Red)	A fatal error has occurred
	OFF	No error present
100MBIT	ON	100Base T Frequency detected
	OFF	(With ACTIVE LED ON) - 10Base T Frequency detected

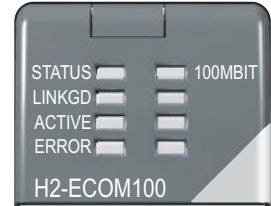

H2-ECOM100 Network Identifiers

Each module must be assigned at least one unique identifier to make it possible for other devices to recognize it on the network. There are four identifiers possible with the ECOM modules:

- Module ID
- Name
- IP (Internet Protocol) Address
- Ethernet (MAC) Address

The first three are user selectable but the MAC address is set at the factory. The type of identifier chosen depends on the requirements of your particular application. PC-to-PLC communication typically uses one type of identifier while PLC-to-PLC communication may require another. The following table summarizes Network Identifiers and their uses:

Network Identifiers				
Identifier	How to Set	Format	Communication	Notes
Module ID	DIP Switch	Number 1–63	PLC-to-PLC or PC-to-PLC	Disables Module ID in NetEdit3
	NetEdit3	Number 1–90	PLC-to-PLC or PC-to-PLC	DIP Switch must be set to “0”
	NetEdit3	Number 1–999,999,999	PC-to-PLC only	>90 (Not for PLC-to-PLC)
Name	NetEdit3	32 Alphanumeric Characters	PC-to-PLC only	HMI software may have restrictions
IP Address	NetEdit3	4 sets of numbers, up to three digits each (192.168.76.3)	PC-to-PLC, (PLC-to-PLC Client/Server using TCP/IP or Modbus TCP protocols)	See your Network Administrator for IP addresses
Ethernet (MAC) Address	Set at Factory	12 Hex digits	PC-to-PLC only	Factory assigned for IPX

Module ID

A Module ID is required for PLC-to-PLC communication and it can be set in two ways:

- Using the DIP switches on the module
- Using the configuration tools in NetEdit3
- HTML configuration (after IP address is assigned to module using NetEdit3)

Use the DIP switches if you want the ability to install or change modules without having to use a PC to set the Module ID. Set the module's DIP switches, install the module in the base and apply power. The Module ID will be accepted on powerup and your ECOM will be ready to communicate.

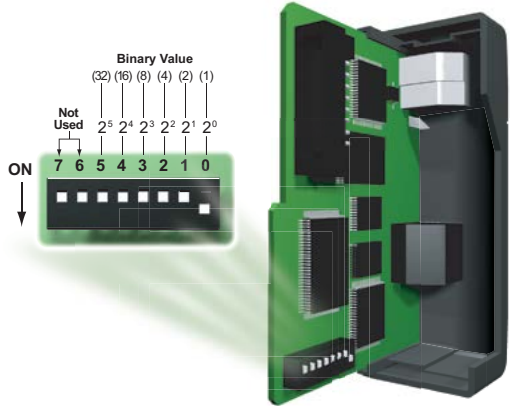

Name

A Name makes it easy to recognize the PLC by its function. An example of a Name is "PumpStationOne", as seen in the diagram below. The Name can be up to 32 alphanumeric characters in length.



NOTE: Some HMI software products will not accept Names with numbers as the first character, spaces or certain other non-alphanumeric ASCII characters. Also, your HMI product may not accept Names longer than 16 characters. Consult your HMI product documentation about its naming conventions.

IP Address

An IP Address can be assigned to the ECOM module if your network requires one. Usually, the IP Address is required in cases where PLCs are sharing the same network with PCs, and some of the PCs are carrying out functions unrelated to PLC control. Normally, a network administrator will assign an IP Address to each device on the network. Use NetEdit3 to configure the assigned IP address to the ECOM.





NOTE: You must use an IP address if you are using the UDP/IP or Modbus TCP protocol.

The module ships from the factory with an IP Address of 0.0.0.0. This is not a usable IP Address for normal communication. It only serves as a default setting which can be changed using NetEdit3. The valid setting for each field is 1 through 254. You do not have to change the default IP Address unless you are using the IP Address to link to your ECOM module. The default setting does not cause conflicts with other network communications. If you change the default IP Address for linking to other network devices, you must change all four “0” fields.

Example IP Addresses - If the Client (PC/ECOM) Subnet Mask is 255.255.0.0 and the Client has an IP Address of 192.168.50.2, then the following are valid Server IP Addresses:

- 192.168.55.5 - Valid Server ECOM IP Address
- 192.168.70.15 - Valid Server ECOM IP Address

The subnet mask determines which fields must match by assigning a 255 to that field. In the example above, the first two fields are masked with a 255, therefore valid Server IP Addresses must match the first two fields of the Client IP or 192.168. The last two fields are allowed to vary because they are masked with a “0”.



WARNING: It is extremely important not to have duplicate IP Addresses on your network. If you are using the IP Address to link the ECOM to any network devices (PCs or PLCs), the ECOM must have a unique number.

Ethernet (MAC) Address

A unique Ethernet (MAC) Address is assigned to each module at the factory and will not change. It is printed on a label attached to each ECOM module. The Ethernet (MAC) Address is recognized by NetEdit3. The Ethernet (MAC) Address is a twelve digit number with no deliberate relationship to your network or functional areas of your plant. Typically, the MAC address is not a convenient and easily remembered identifier for your ECOM module.



Using Multiple Network Identifiers

You can use IP Addresses to satisfy network requirements, the Name identifier for PCs running HMI software and Module IDs for PLCs to share data among themselves. Using one type of identifier does not limit your use of the other identifier types.

H2-ECOM100 Network Layouts

The ECOM Ethernet network is a peer-to-peer network. Using Read (RX) or Write (WX) instructions, any PLC on the network can initiate communications with any other PLC on the network. A PC running our KEPDirect software can also initiate communications with any ECOM that is on the same network, but a PLC cannot initiate communication with the PC. An ECOM can sequence through communication connections with each PLC on the network, one at a time.

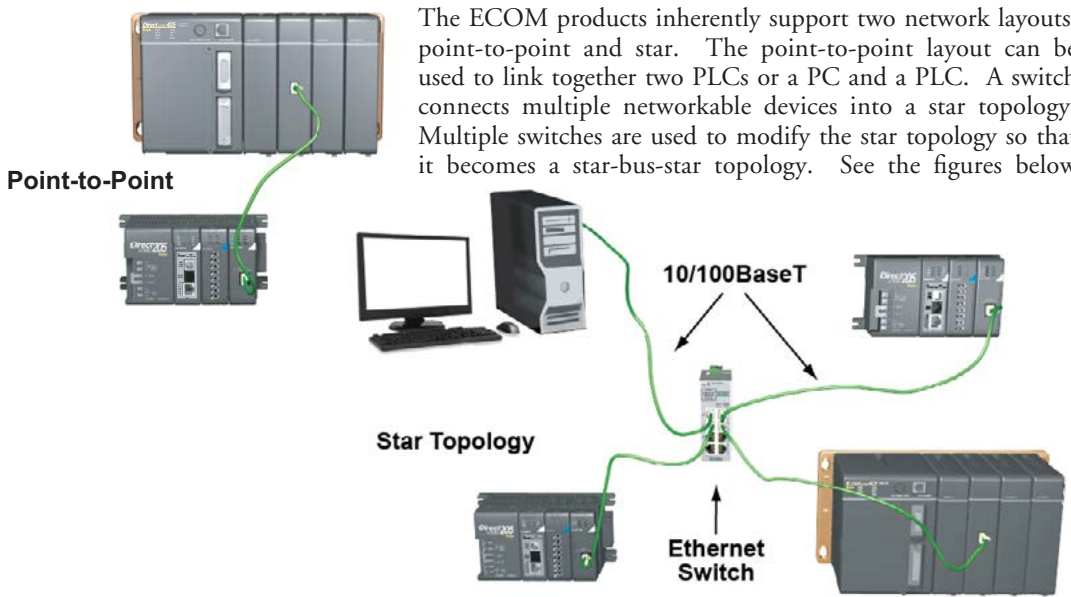

Switches can connect together to make it possible to connect more devices to the network or to extend the range of the network.

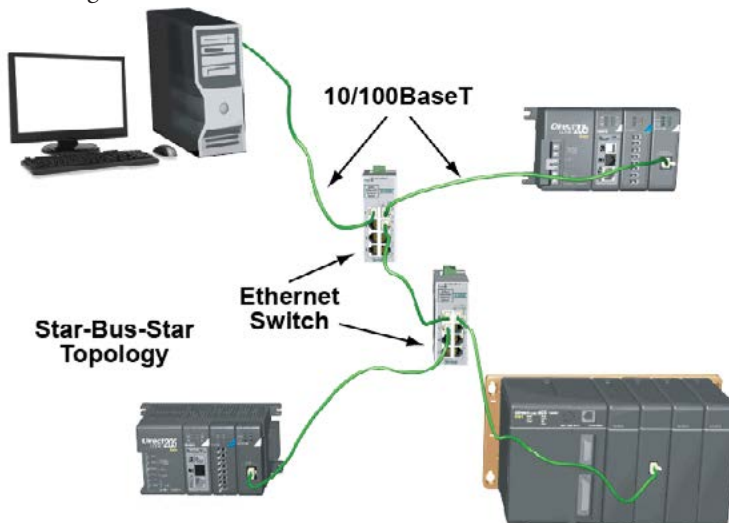

H2-ECOM100 Network Cabling

The H2-ECOM100 module supports 10/100BaseT standard cabling consisting of copper wire twisted pairs.

10/100BaseT
Unshielded Twisted-
Pair cable with RJ45
connectors



10/100 BaseT Networks

The cable used to connect a PLC (or PC) to an Ethernet switch is called a patch (straight-through) cable. The cable used to connect together two PLCs, a PC and a PLC, or two switches is a crossover cable. We recommend that you purchase cables pre-assembled with connectors for convenient and reliable networking.

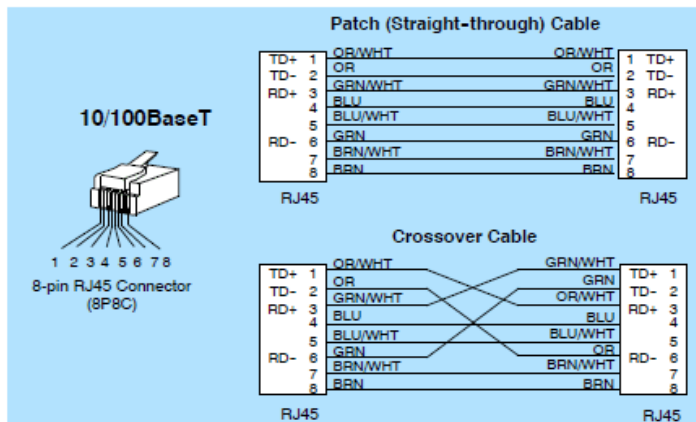

NOTE: The above diagram illustrates the standard wire positions in the RJ45 connector. We recommend all ECOM 10/100BaseT cables to be Category 5, UTP cable.

Cable Lengths

The maximum distance per 10/100BaseT cable segment is 100 meters or 328 feet. Switches allow multiple 100 meter cable segments to be joined together increasing the allowable distance. For example, two switches connected together adds an additional 200 meters to the system, for a total range of 300 meters.

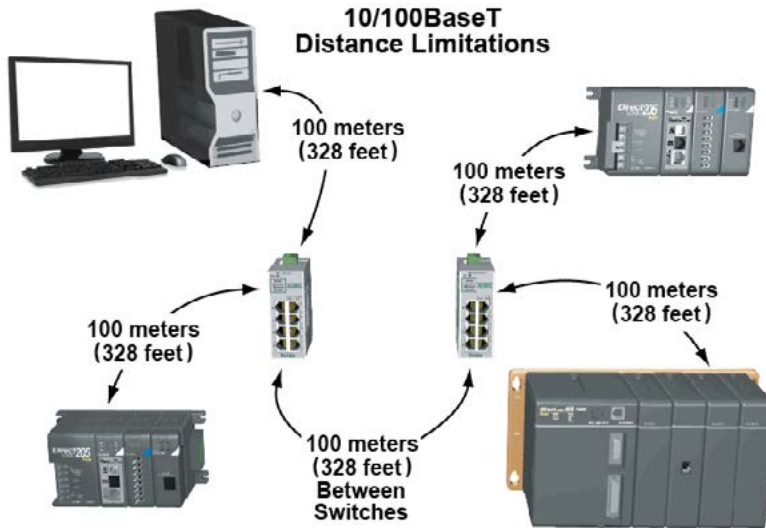

Maximum Number of ECOM Modules on the Network

The maximum number of nodes that can be connected to a 10/100BaseT network is a function of the topology used in constructing the network. Therefore, it is not possible to state an absolute maximum number of nodes that would apply in all cases.

The IEEE 802.3 specification defines the maximum node limit for an Ethernet segment in terms of the ability to detect and avoid data collisions. A “legal” network can have any number of devices provided that they can:

- Detect all data collisions that may occur during the communication process and
- Respond to these collisions appropriately.

You must take into consideration the network limitations imposed by all cabling and network devices. Consider the limitations imposed on your network if your network uses:

- A combination of cabling standards, such as 10/100 BaseT and 10Base2, or
- Intermediate devices, such as switches or routers.

Each ECOM module can be assigned a Module ID ranging from 1 to 999,999,999. Theoretically, you could have this many Ethernet modules coexisting on a single network. Other network limitations would restrict the network size before reaching this limit. For the majority of network PLC applications there is practically no limit to the number of ECOM modules you can access from the NetEdit3 or Do-more Designer software. There is a node limit for PLC-to-PLC communications. The network Read and Write instructions performed by the initiating (master) PLC are only capable of accessing PLCs with Module IDs of 1 through 90. This effectively sets the maximum number of nodes available for PLC-to-PLC communications at 90.



WARNING: We recommend against connecting Ethernet modules to the same network that serves as your primary office network. While Ethernet networks can handle a very large number of data transmissions, and normally handle them very quickly, heavy Ethernet traffic can adversely affect the reliability and speed of the network.

H2-ERM(100)/ H2-EBC100*



NOTE: The H2-ERM module has been discontinued. The H2-ERM100 is the replacement module.

H2-ERM(100) Overview

Expanding I/O beyond the local chassis is useful for a system which has a sufficient number of sensors and other field devices located a relatively long distance from the CPU. The Ethernet Remote Master H2-ERM(100) connects Do-more CPU systems to slave I/O over a high-speed Ethernet link.

Each ERM module can support up to 16 H2-EBC systems, 16 Terminator I/O EBC systems, or 16 fully expanded H4-EBC systems. Of course, combinations are fine, too.



NOTE: Applications requiring an extremely large number of T1H-EBC analog I/O or H4-EBC 16-channel analog I/O, could exceed the buffer capacity of a single H2-ERM(100) module. In these cases, an additional H2-ERM(100) may be required.

The ERM connects to your control network using Category 5 UTP cables for cable runs up to 100 meters (328ft). Use Ethernet switches to extend distances and expand the number of nodes.

The PLC, ERM and EBC slave modules work together to update the remote I/O points. These three scan cycles are occurring at the same time, but asynchronously. Critical I/O points that must be monitored every scan are best placed in the CPU base.

It is highly recommended that a dedicated Ethernet remote I/O network be used for the ERM and its slaves. While Ethernet networks can handle a large number of data transactions, and normally handle them very quickly, heavy Ethernet traffic can adversely affect the reliability of the slave I/O and the speed of the I/O network. Ensure ERM networks, multiple ERM networks and ECOM/office networks are isolated from one another.

H2-ERM(100) Specifications

H2-ERM(100) Ethernet Remote I/O Master Module		
Specifications	H2-ERM	H2-ERM100
Module Type	Ethernet Communications Master Module	
Slaves per ERM	16 Max	
Communications	10BaseT Ethernet	10/100BaseT Ethernet
Data Transfer Rate	10Mbps	100Mbps
Ethernet Port	RJ45	
Power Consumption	320mA @5VDC	300mA @5VDC
Operating Environment	0°C to 60°C (32°F to 140°F), 35% to 95% humidity (non-condensing)	
Link Distance	100m (328ft)	
Ethernet Protocols	TCP/IP, IPX	TCP/IP, IPX Modbus TCP/IP, DHCP, HTML configuration



H2-ERM(100) LED Indicators

H2-ERM(100) LED Descriptions		
Indicator	Status	Description
LINKGD	ON	Communications Link OK
ACTIVE	ON	Network Active
	OFF	Network Idle
ERROR	ON or Flashing	Fatal Error Detected



H2-EBC100 Overview

The Ethernet Base Controller (EBC) serves as an interface between the master control system and remote I/O modules. The control function is performed by the master controller, not the EBC slave. The EBC occupies the CPU slot in the base and communicates across the backplane to input and output modules. The function of the EBC is to:

- Process analog and digital input signals
- Format the I/O signals to conform to the Ethernet standard
- Transmit input signals to the network master
- Receive and translate output signals from the network master
- Distribute the output signals to the appropriate output module in the base

The H2-EBC100 module supports industry standard 10/100BaseT Ethernet and Ethernet/IP communications.



NOTE: The RS-232 serial port on the EBC module cannot be used when the EBC module is part of the Do-more controller system.

H2-EBC100 Specifications

Specifications	H2-EBC100
Communications	10/100BaseT Ethernet
Data Transfer Rate	100Mbps max.
Link Distance	100 meters (328ft)
Ethernet Port	RJ45
Ethernet Protocols	Ethernet/IP, TCP/IP, IPX/Modbus TCP/IP, DHCP, HTML configuration
Serial Port*	RJ12
Serial Protocols	K-Sequence, ASCII IN/OUT, Modbus RTU
Power Consumption	300mA @ 5VDC

* The serial port on the EBC modules cannot be used when the H2-DM1/E is the network master.

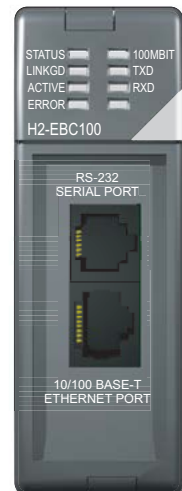

H2-EBC100 LED Indicators

H2-EBC100 LED Descriptions		
Indicator	Status	Description
STATUS	ON (Green)	Module is powered up and functional
	OFF	Module powerup failed
LINKGD	ON (Green)	Properly connected to network
	OFF	Not connected to network or incorrect configuration
ACTIVE	ON or FLASHING (Red)	Active Network Data
	OFF	Network Idle
ERROR	ON or FLASHING (Red)	A fatal error has occurred
	OFF	No error present
100MBIT	ON	100Base T Frequency detected
	OFF	(With ACTIVE LED ON) - 10Base T Frequency detected
TXD	FLASHING (green)	Serial port is transmitting data
RXD	FLASHING (green)	Serial port is receiving data

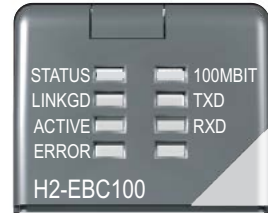

H2-ERM(100)/H2-EBC100 Network Identifiers

Each module must be assigned at least one unique identifier to make it possible for other devices to recognize it on the network. There are three identifiers possible with the ERM/EBC modules:

- Module ID
- IP (Internet Protocol) Address
- Ethernet (MAC) Address

The first two are user selectable but the MAC address is set at the factory. The identifiers are used to link the ERM module to its remote EBC slaves. The type of identifier chosen depends on the protocol requirements of your particular application. The following table summarizes Network Identifiers and their uses:

Network Identifiers				
Identifier	Protocol	How to Set	Format	Notes
Module ID	IPX	DIP Switch	Slave Number 1-63, Set ERM to 0	Module ID can be changed without NetEdit3. When set, disables Module ID selection in NetEdit3
		NetEdit3	Slave Number 1-65535, Set ERM to 0	
IP Address	UDP/IP	NetEdit3	4 sets of numbers, up to three digits each (192.168.76.3)	See your Network Administrator for IP addresses
Ethernet (MAC) Address	IPX	Set at Factory	12 Hex digits	Factory assigned for IPX

Module ID

Always set the ERM module ID to 0. A slave EBC Module ID can be set in one of two ways:

- Use the DIP switches on the module (1-63).
- Use the configuration tools in NetEdit3 (1-65535).

Set the Module ID using the DIP switches if you wish to be able to install and change slave modules without using a PC. The Module ID equals the *sum* of the binary values of the slide switches set in the ON position. For example, if slide switches 1, 2 and 3 are set to the ON position, the Module ID will be 14. This is found by adding $8+4+2=14$. The maximum value which can be set on the DIP switch is $32+16+8+4+2=63$. This is achieved by setting switches 0 through 5 to the ON position. The 6 and 7 switch positions are inactive.

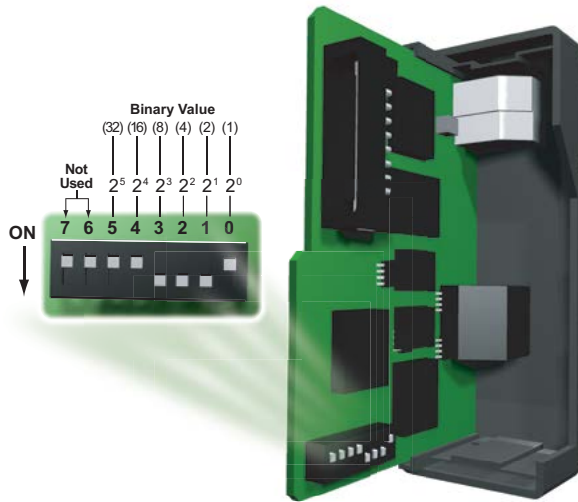

H2-ERM(100)/H2-EBC Module

H2-ERM(100)/H2-EBC Module DIP Switch Location

Set the module's DIP switch, insert the module in the base, and connect the network cable. The Module ID is set on powerup, and it is ready to communicate on the network.

The Module IDs can also be set or changed on the network from a single PC by using the tools in NetEdit3.

IP Address

An IP Address can be assigned to the ERM module or its slaves if your network requires one. Normally, a network administrator will assign an IP Address to each device on the network. Since it is recommended to use a separate dedicated network for your ERM, you do not have to use the IP Address, unless you are using the UDP/IP protocol. Use the Module ID or Ethernet Address for each module when using the IPX protocol. You can use NetEdit3 within the ERM Workbench utility to give the ERM or its slave modules an IP Address. Each ERM and slave must have a unique IP Address.

The module ships from the factory with an IP Address of 255.255.255.255. This is not a usable IP Address for normal communications. It only serves as a default setting which can be changed using NetEdit3. The valid settings are 0 through 254. You do not have to change the default IP Address unless you are using IP Address protocol. The default setting does not cause conflicts with other network communications. If you change the default IP Address for linking to other network devices, you must change all four “255” fields. If any field contains the number 255 and other fields have been changed, the module will not be recognized on the network.

Example IP Addresses

- 192.168.55.5 - Valid IP Address
- 255.168.55.5 - Not Valid



WARNING: It is extremely important not to have duplicate IP Addresses on your network. If you are using the IP Address, all modules must have a unique number.

Ethernet (MAC) Address

A unique Ethernet (MAC) Address is assigned to each module at the factory and will not change. It is printed on a label attached to each ERM/EBC module. The Ethernet (MAC) Address is recognized by NetEdit3. The Ethernet (MAC) Address is a twelve digit number with no deliberate relationship to your network or functional areas of your plant. Typically, the MAC address is not a convenient and easily remembered identifier for your ERM/EBC module.



Using Multiple Network Identifiers

You can use IP Addresses to satisfy network requirements and Module IDs for PLCs to share data among themselves. Using one type of identifier does not limit your use of the other identifier types.

H2-ERM(100)/H2-EBC100 Network Layouts

Each ERM module can support up to 16 remote slaves. The slaves supported are the H4-EBC, H2-EBC, T1H-EBC, GS-EDRV100 and HA-EDRV2. Use a PC equipped with a 10/100BaseT network adapter card and the Ethernet Remote Master (ERM) Workbench software configuration utility to configure the ERM module and its slaves over the Ethernet remote I/O network. Once the ERM I/O network is configured and running, the PC can be removed from the network.

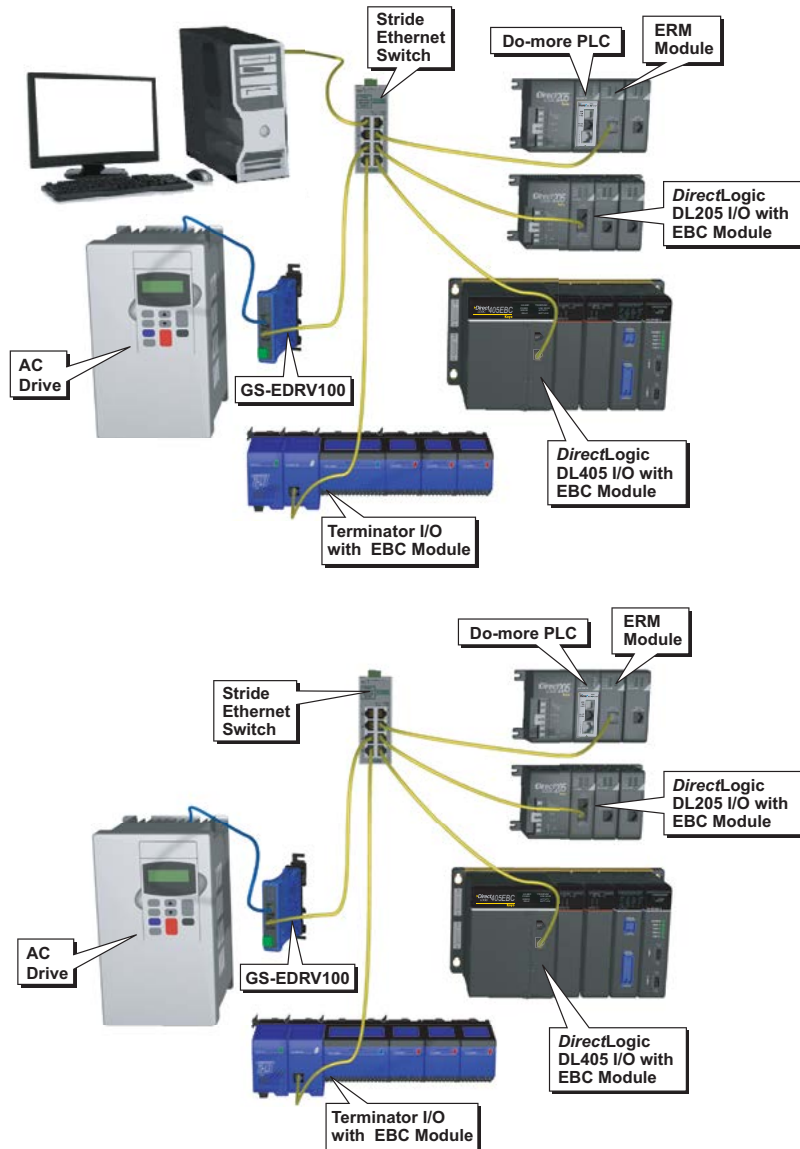

H2-ERM(100)/H2-EBC100 Network Cabling

The ERM/EBC modules support 10/100BaseT standard cabling consisting of copper wire twisted pairs.

10/100BaseT
Unshielded Twisted-
Pair cable with RJ45
connectors



10/100 BaseT Networks

The cable used to connect a PLC (or PC) to an Ethernet switch is called a patch (straight-through) cable. The cable used to connect together two PLCs, a PC and a PLC, or two switches is a crossover cable. We recommend that you purchase cables pre-assembled with connectors for convenient and reliable networking.

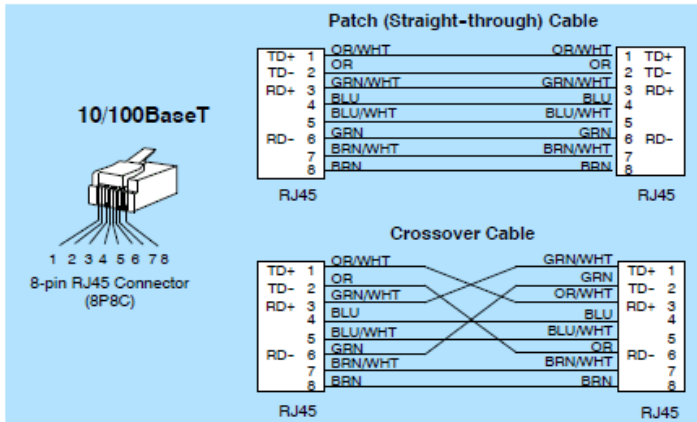

NOTE: The above diagram illustrates the standard wire positions in the RJ45 connector. We recommend all ECOM 10/100BaseT cables to be Category 5, UTP cable.

Cable Lengths

The maximum distance per 10/100BaseT cable segment is 100 meters or 328 feet. Switches allow multiple 100 meter cable segments to be joined together increasing the allowable distance. For example, two switches connected together adds an additional 200 meters to the system, for a total range of 300 meters.

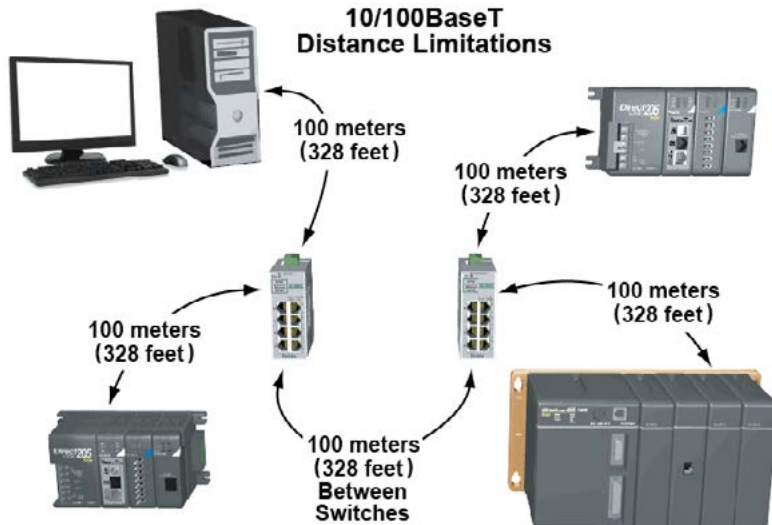

H2-SERIO(-4)

H2-SERIO(-4) Overview

With the H2-SERIO, three additional RS-232 ports can be added to your Do-more system. On the other hand, the H2-SERIO-4 can give you two additional RS-232 ports and one RS-485 or RS-422 port. As many as eight of these modules may be added to the local base, adding up to 24 serial ports (there is no means of using these modules in Ethernet remote bases).

The serial ports of the H2-SERIO(-4) support the following functions which can be selected in the Module Configuration of the Do-more software (as seen below):

- Do-more Programming - Select this option to setup the port to work with the Do-more Designer programming software.
- K Sequence - Select this option to have the port respond to client devices running K Sequence protocol.
- Modbus RTU Server - Select this option to have the port respond to client devices running Modbus/RTU protocol.
- Modbus RTU Client - Select this option to make the port available for use by the Do-more controller's Modbus Network Read (MRX) and Modbus Network Write (MWX) instructions.
- General Purpose - Select this option to make the port available for use by the Do-more controller's Input String from Device (STREAMIN) and Output String to Device (STREAMOUT) instructions.

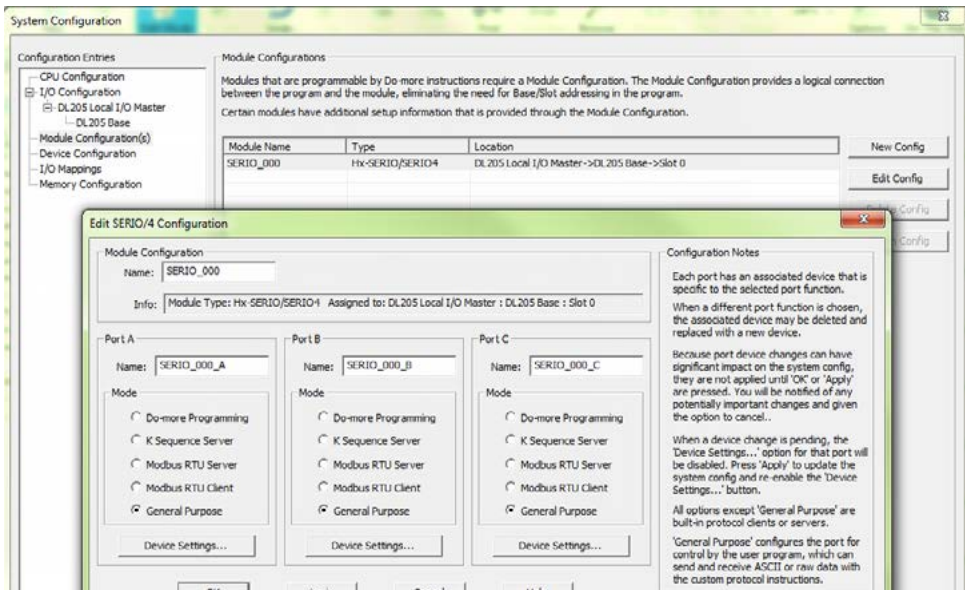

Baud rates, parity and communication bit settings are accessible by selecting the Device Settings... button located below the General Purpose selection or through the Device Configuration section of the System Configuration window. Baud rates up to 115,200 are supported.

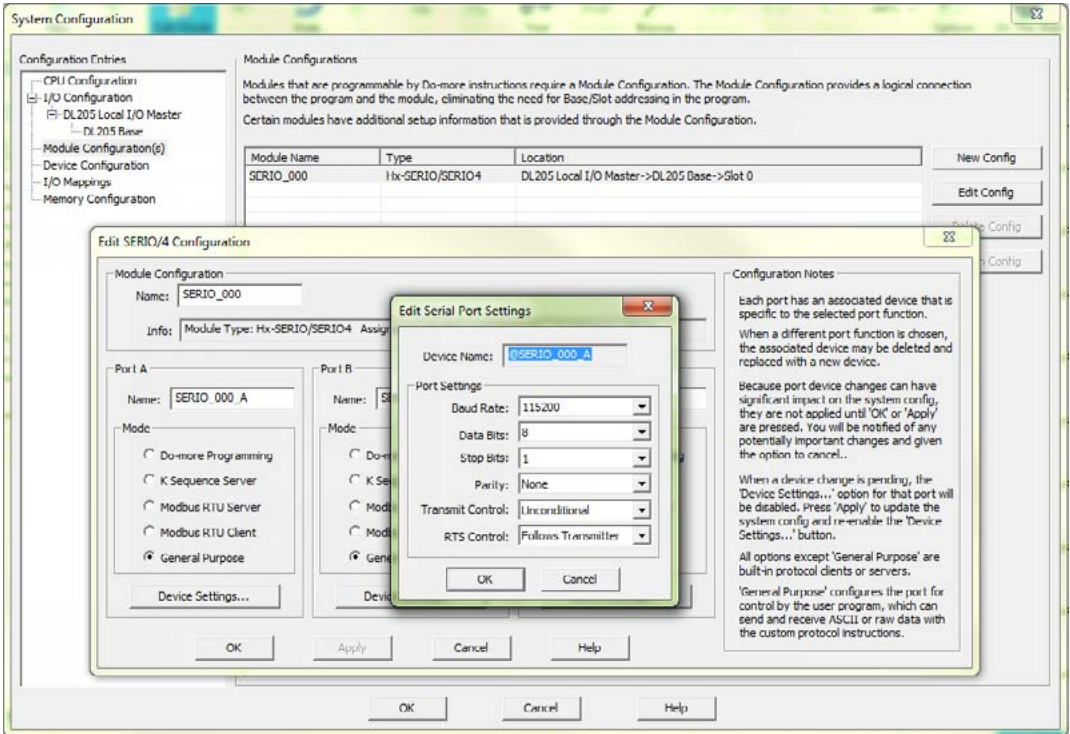

These parameters can also be set programmatically using the SETUPSER instruction seen here. See the Do-more Help file for more information on communication instructions.

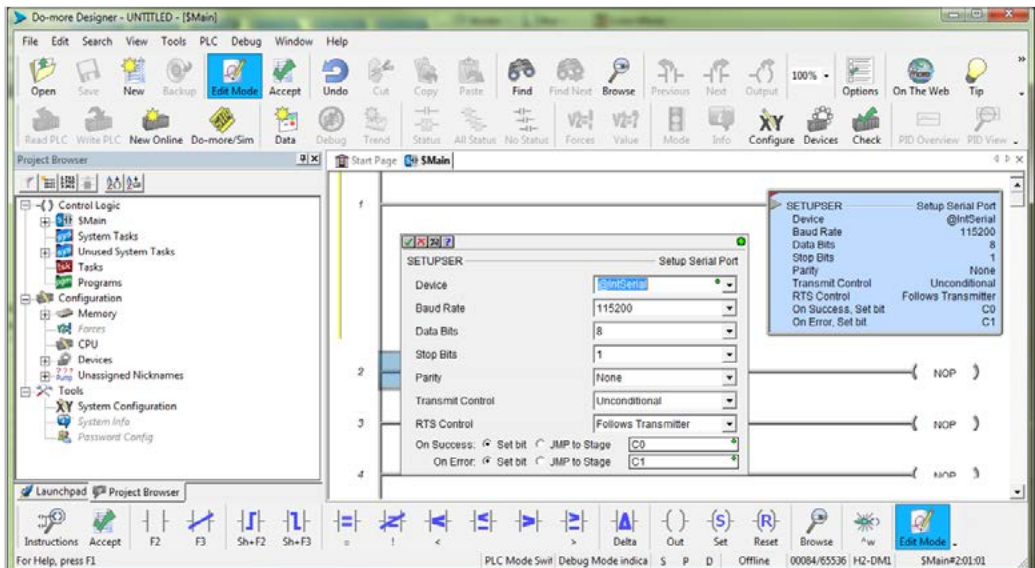

H2-SERIO(-4) Specifications

H2-SERIO / H2-SERIO-4 Serial Communications Module		
Specifications	H2-SERIO	H2-SERIO-4
Module Type	Intelligent	
Approvals	cUL Listed, file number E185989	
Number of Serial Ports per Module	3 ports: all RS-232 (RJ12 jack)	3 ports: 2 RS-232 ports (RJ12 jack), and 1 RS-422/485 (5 position terminal strip)
Signals	RS-232: CTS, RXD, TXD RTS, GND RTS transmission delay times: 5, 50, 250 and 500ms	RS-232: CTS, RXD, TXD RTS, GND RTS transmission delay times: 5, 50, 250 and 500ms RS-422 (4 wire): TX+, TX-, RX-, RX+, GND RS-485 (2 wire): Data+, Data-, GND
Number of Modules Supported per Do-more PLC	8	
Recommended Cables	RS-232: ZL-RJ12CBL-2	RS-232: ZL-RJ12CBL-2 RS-422: ADC L19853-x (Belden 8103) RS-485: ADC L19954-x (Belden 9842)
Protocols Supported	Serial ASCII (full-duplex), K Sequence, Modbus/RTU and Do-more programming	
Power Consumption	80mA @ 5VDC	
Baud Rates	1200, 2400, 4800, 9600, 19200, 38400, 57600, 115200	
Parity	None, odd, even	
Start and Stop Bits	1, 2	
Operating Environment	0 to 60°C (32°F to 140°F), 5% to 95% RH (non-condensing); No corrosive gases, Pollution level 2; Vibration: MIL STD 810C 514.2; Shock: MIL STD 810C 516.2	
Storage Temperature	-20 to 70°C (-4°F to 158°F)	

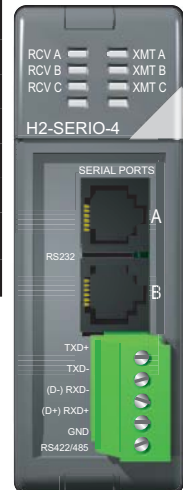
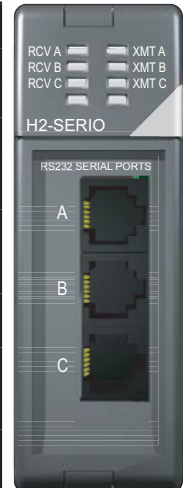

H2-SERIO(-4) Wiring: RS-232

RS-232

6 pin RJ12 Phone Type Jack – both por

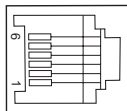

H2-SERIO(-4) RS-232 Pin Descriptions		
1	0V	Power (-) connection (GND)
2	CTS	Clear to Send
3	RXD	Receive data (RS-232)
4	TXD	Transmit data (RS-232)
5	RTS	Request to Send
6	0V	Signal Ground (GND)

H2-SERIO-4 Wiring: RS-422/485

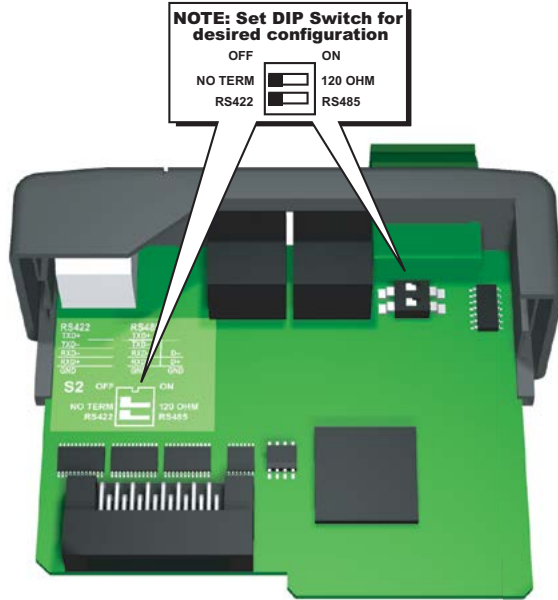

Set DIP switch S2 on the H2-SERIO-4 to:

1. Activate or deactivate the internal 120Ω termination resistor.
2. Select RS-422 or RS-485 operation.

RS-422

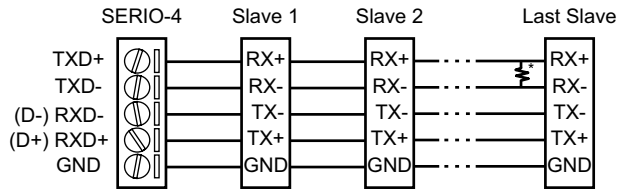

(H2-SERIO-4 contains an optional 120Ω termination resistor between RX+ and RX-; use DIP switch S2 to activate or deactivate resistor.)

* User Supplied 120Ω Termination Resistor

RS-485

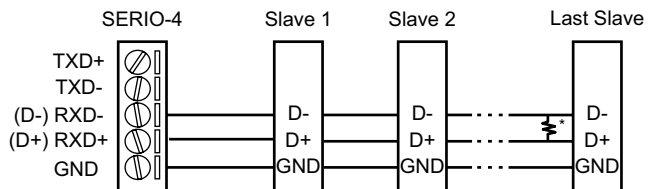

(H2-SERIO-4 contains an optional 120Ω termination resistor between RX+ and RX-; use DIP switch S2 to activate or deactivate resistor. H2-SERIO-4 also contains internal biasing to be a true failsafe receiver while maintaining EIA/TIA-485 compatibility.)

* User Supplied 120Ω Termination Resistor

F2-08SIM, Input Simulator

F2-08SIM Specifications

F2-08SIM Input Simulator	
Inputs per Module	8
Base Power Required 5VDC	50mA
Terminal Type	None
Status Indicator	Switch side
Weight	2.65 oz. (75g)

