

# INSTALLATION AND WIRING

---



## CHAPTER

# 2

### TABLE OF CONTENTS

#### Chapter 2: Installation and Wiring

Drive Models by Frame Size . . . . .	2-2
Installation . . . . .	2-2
Minimum Clearances and Air Flow. . . . .	2-3
GS30 Series Minimum Clearance Distances . . . . .	2-3
GS30 Airflow and Power Dissipation . . . . .	2-4
Dimensions. . . . .	2-5
Circuit Connections – RFI Jumper . . . . .	2-15
RFI Jumper Removal. . . . .	2-15
Isolating Main Power from Ground . . . . .	2-16
Floating Ground System (IT Systems) . . . . .	2-17
Asymmetric Ground System (Corner Grounded TN Systems) . . . . .	2-17
Circuit Connections – Warnings and Notes . . . . .	2-18
Wiring Terminal Access . . . . .	2-22
Control Terminal Access. . . . .	2-22
Main Circuit Wiring Terminals . . . . .	2-23
Main Terminal Specifications . . . . .	2-23
Wiring Terminal Connector Dimensions – Main-Circuit Terminals. . . . .	2-25
Main Terminal Diagrams . . . . .	2-26
Main Circuit Wiring Diagrams . . . . .	2-29
Control Circuit Wiring Terminals . . . . .	2-30
GS30 Control Terminal Specifications . . . . .	2-30
GS30 Control Terminal Block Diagram & Wiring Specifications . . . . .	2-33
Control Terminal Wiring Instructions. . . . .	2-34
Control Circuit Wiring Diagrams . . . . .	2-35
Digital Inputs. . . . .	2-35
System Wiring Diagram. . . . .	2-36
Full I/O Wiring Diagram (Frame A-G) . . . . .	2-37
Full I/O Wiring Diagram (Frame H-I) . . . . .	2-38

## DRIVE MODELS BY FRAME SIZE

GS30 DURAPULSE Drive Models by Frame Size	
Frame	Drive
<b>A</b>	GS31-20P5, GS33-20P5, GS33-21P0, GS33-40P5, GS33-41P0
<b>B</b>	GS31-21P0, GS33-22P0, GS33-42P0
<b>C</b>	GS31-22P0, GS31-23P0, GS33-23P0, GS33-25P0, GS33-43P0, GS33-45P0
<b>D</b>	GS33-27P5, GS33-47P5, GS33-4010,
<b>E</b>	GS33-2010, GS33-2015, GS33-4015, GS33-4020
<b>F</b>	GS33-2020, GS33-4025, GS33-4030
<b>G</b>	GS33-2025 GS33-2030, GS33-4040
<b>H</b>	GS33-4050, GS33-4060
<b>I</b>	GS33-2040, GS33-2050, GS33-4075, GS33-4100

## INSTALLATION

Install the AC drive in an enclosure that is specifically designed to house electrical and electronic control equipment. Provide proper spacing within the enclosure to allow the dissipation of heat produced by the drive and any other included electrical and electronic equipment. Ventilation or air conditioning may also be required, depending upon the application.



*FAILURE TO OBSERVE THESE PRECAUTIONS MAY DAMAGE THE DRIVE AND VOID THE WARRANTY!*

Improper installation of the AC drive will greatly reduce its life. Observe the following precautions when installing the drive:

- Do not mount the AC drive near heat-radiating elements or in direct sunlight.
- Do not install the AC drive in a place subjected to high temperature, high humidity, excessive vibration, corrosive gases or liquids, or airborne dust or metallic particles.
- Install the AC drive in Pollution Degree 2 environments only.  
Pollution Degree 2: Normally only non-conductive pollution occurs. Temporary conductivity caused by condensation is to be expected.
- Install the AC drive in a cabinet. When installing one drive below another, use a metal separator between the drives to prevent mutual heating and to prevent the risk of fire.
- Mount the AC drive securely on a flat, rigid, non-flammable surface.
- Mount the AC drive vertically and do not restrict the air flow to the heat sink fins and fan(s) (if equipped).
- Prevent fiber particles, scraps of paper, shredded wood saw dust, metal particles, etc. from adhering to the heat sink.



*AC DRIVES GENERATE A LARGE AMOUNT OF HEAT WHICH MAY DAMAGE THEM. AUXILIARY COOLING METHODS ARE TYPICALLY REQUIRED IN ORDER NOT TO EXCEED MAXIMUM AMBIENT TEMPERATURES.*

## MINIMUM CLEARANCES AND AIR FLOW

### DIAGRAM DIRECTIONAL ARROWS

- Air Inflow: Blue Arrow → →
- Air Outflow: Red Arrow → →
- Distance: Black Arrows ↔ ↔

### GS30 SERIES MINIMUM CLEARANCE DISTANCES

#### 1) SINGLE DRIVE INSTALLATION (FRAMES A-I)

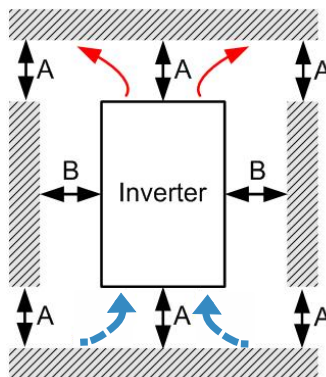

#### 2) MULTIPLE DRIVES SIDE-BY-SIDE

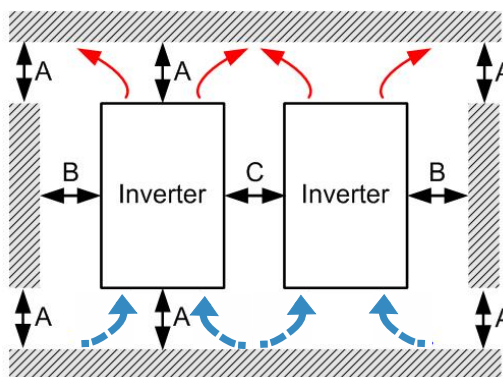

GS30 Minimum Mounting Clearances*								
Installation Method	Frame A-F			Frame G-I			Operation Temperature (°C)[°F]	
	A	B	C	A	B	C	Max (w/out derating)	Max (Derating)
	(mm)[in]							
Single drive installation	50 [1.97]	30 [1.18]	–	100 [3.94]	50 [1.97]	–	50 [122]	60 [140]
Side-by-side horizontal installation	50 [1.97]	30 [1.18]	30 [1.18]	100 [3.94]	50 [1.97]	50 [1.97]	50 [122]	60 [140]
Zero stack installation	50 [1.97]	30 [1.18]	0	100 [3.94]	50 [1.97]	0	40 [104]	50 [122]

\* The minimum mounting clearances stated in this table apply to GS30 drives. Failure to follow the minimum mounting clearances may cause the fan to malfunction and cause a heat dissipation problem.

**GS30 AIRFLOW AND POWER DISSIPATION**

GS30 Airflow and Power Dissipation						
Model Number	Frame Size	Airflow Rate for Cooling		Power Dissipation (Watts)		
		Flow Rate (cfm)	Flow Rate (m <sup>3</sup> /hr)	Loss External (Heat sink)	Internal	Total
GS31-20P5	A	0.0	0.0	16.3	14.5	30.8
GS31-21P0	B	0.0	0.0	31.1	22.5	53.6
GS31-22P0	C	16.0	27.2	46.5	31.0	77.5
GS31-23P0				70.0	35	105
GS33-20P5	A	0.0	0.0	16.5	12.6	29.1
GS33-21P0				33.2	15.0	48.2
GS33-22P0	B	10.0	16.99	50.1	24.2	74.3
GS33-23P0	C	16.0	27.2	76.0	30.7	106.7
GS33-25P0				108.2	40.1	148.3
GS33-27P5	D	23.4	39.7	192.8	53.3	246.1
GS33-2010	E	53.7	91.2	244.5	79.6	324.1
GS33-2015				374.2	86.2	460.4
GS33-2020	F	67.9	115.2	492.0	198.2	690.2
GS33-2025	G	232.0	394.2	581.3	100.0	681.3
GS33-2030				732.5	107.0	839.5
GS33-2040	I	455.0	773.1	926.0	124.0	1050.0
GS33-2050				1144.9	132.0	1276.9
GS33-40P5	A	0.0	0.0	17.6	11.1	28.7
GS33-41P0				32.6	20.0	52.6
GS33-42P0	B	10.0	16.99	45.9	21.7	67.6
GS33-43P0	C	16.0	27.2	60.6	22.8	83.4
GS33-45P0				93.1	42	135.1
GS33-47P5	D	23.4	39.7	132.8	39.5	172.3
GS33-4010				164.7	55.8	220.5
GS33-4015	E	53.7	91.2	234.5	69.8	304.3
GS33-4020				319.8	74.3	394.1
GS33-4025	F	67.9	115.2	423.5	181.6	605.1
GS33-4030				501.1	200.3	701.4
GS33-4040	G	266.0	451.9	655.3	122.0	777.3
GS33-4050	H	322.0	547.1	896.8	135.0	1031.8
GS33-4060				1029.0	150.0	1179.0
GS33-4075	I	455.0	773.1	1219.9	165.0	1384.9
GS33-4100				1495.0	180.0	1675.0

- Published flow rates are the result of active cooling using fans, factory installed in the drive.
- Unpublished flow rates (0.0) are the result of passive cooling in drives without factory installed fans.
- The required airflow shown in the chart is for installing a single GS30 drive in a confined space.
- When installing multiple GS30 drives, the required air volume would be the required air volume for a single GS30 drive multiplied by the number of GS30 drives.
- When calculating power dissipation (Watt Loss), use the Total value. Heat dissipation shown in the chart is for installing a single GS30 drive in a confined space.
- When installing multiple drives, the volume of heat/power dissipation should be the heat/power dissipated by a single GS30 drive multiplied by the number of GS30 drives.
- Heat dissipation for each model is calculated by rated voltage, current and default carrier frequency.

**DIMENSIONS**

See our website for complete engineering drawings and 3D models.

<b>GS30 DURAPULSE Frame Sizes by Drive Model</b>				
<b>230V</b>			<b>460V</b>	
<i>Drive</i>	<i>Frame</i>		<i>Drive</i>	<i>Frame</i>
<i>GS31-20P5</i>	<i>A2</i>		<i>GS33-40P5</i>	<i>A2</i>
<i>GS31-21P0</i>	<i>B2</i>		<i>GS33-41P0</i>	<i>A3</i>
<i>GS31-22P0</i>	<i>C1</i>		<i>GS33-42P0</i>	<i>B1</i>
<i>GS31-23P0</i>	<i>C1</i>		<i>GS33-43P0</i>	<i>C1</i>
<i>GS33-20P5</i>	<i>A2</i>		<i>GS33-45P0</i>	<i>C1</i>
<i>GS33-21P0</i>	<i>A3</i>		<i>GS33-47P5</i>	<i>D1</i>
<i>GS33-22P0</i>	<i>B1</i>		<i>GS33-4010</i>	<i>D1</i>
<i>GS33-23P0</i>	<i>C1</i>		<i>GS33-4015</i>	<i>E1</i>
<i>GS33-25P0</i>	<i>C1</i>		<i>GS33-4020</i>	<i>E1</i>
<i>GS33-27P5</i>	<i>D1</i>		<i>GS33-4025</i>	<i>F1</i>
<i>GS33-2010</i>	<i>E1</i>		<i>GS33-4030</i>	<i>F1</i>
<i>GS33-2015</i>	<i>E1</i>		<i>GS33-4040</i>	<i>G</i>
<i>GS33-2020</i>	<i>F1</i>		<i>GS33-4050</i>	<i>H</i>
<i>GS33-2025</i>	<i>G</i>		<i>GS33-4060</i>	<i>H</i>
<i>GS33-2030</i>	<i>G</i>		<i>GS33-4075</i>	<i>I</i>
<i>GS33-2040</i>	<i>I</i>		<i>GS33-4100</i>	<i>I</i>
<i>GS33-2050</i>	<i>I</i>			

**DIMENSIONS (Units = mm [in])**

See our website [www.AutomationDirect.com](http://www.AutomationDirect.com) for complete engineering drawings and 3D models.

**GS30 FRAME SIZE A**

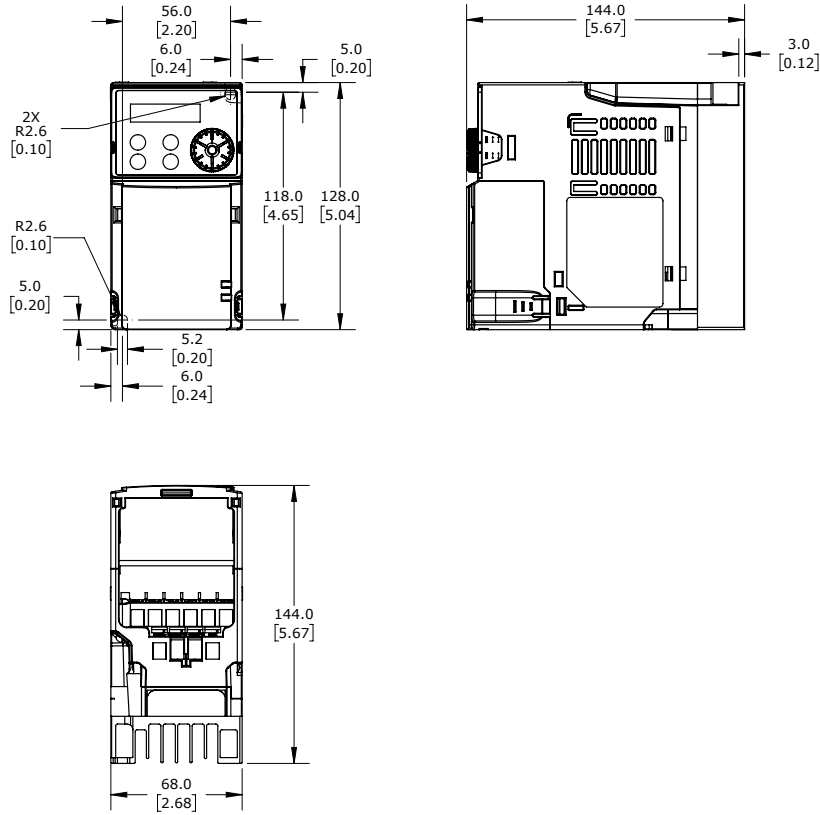

**GS30 FRAME SIZE A CONDUIT BOX**

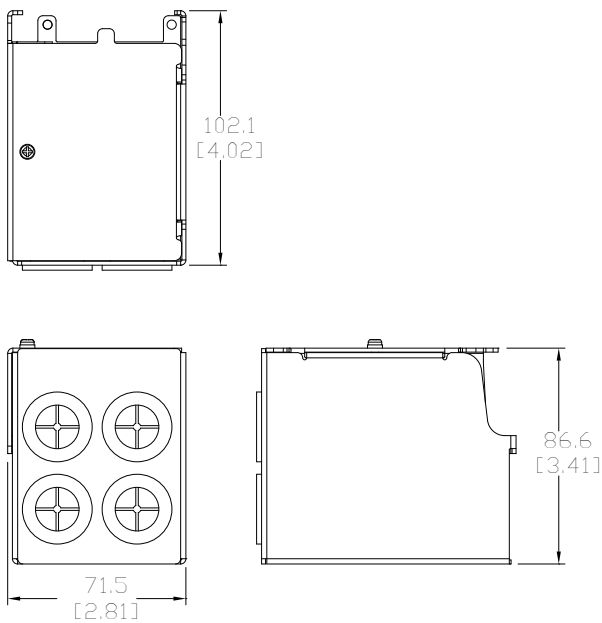

**DIMENSIONS (Units = mm [in])**

See our website [www.AutomationDirect.com](http://www.AutomationDirect.com) for complete engineering drawings and 3D models.

**GS30 FRAME SIZE B**

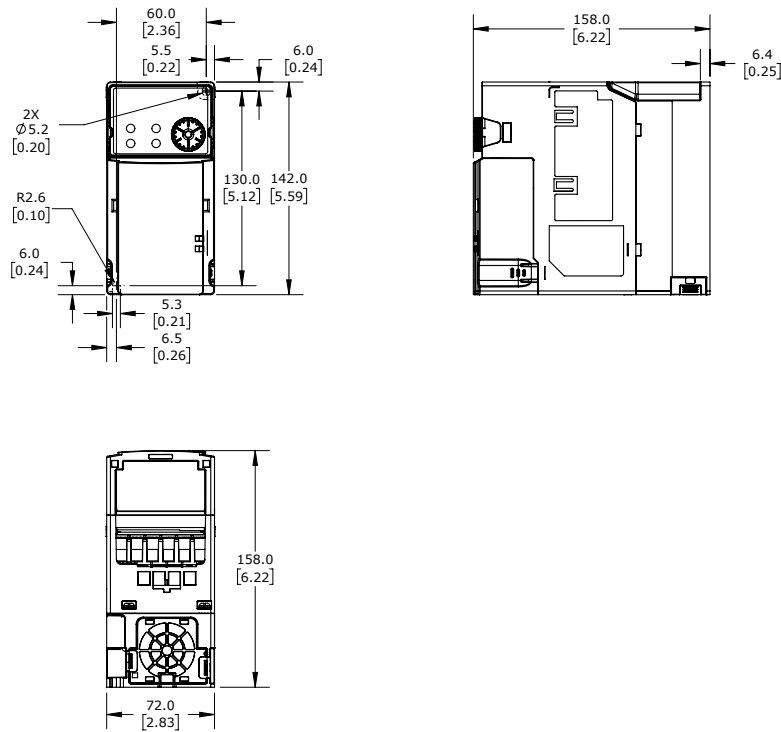

**GS30 FRAME SIZE B CONDUIT BOX**

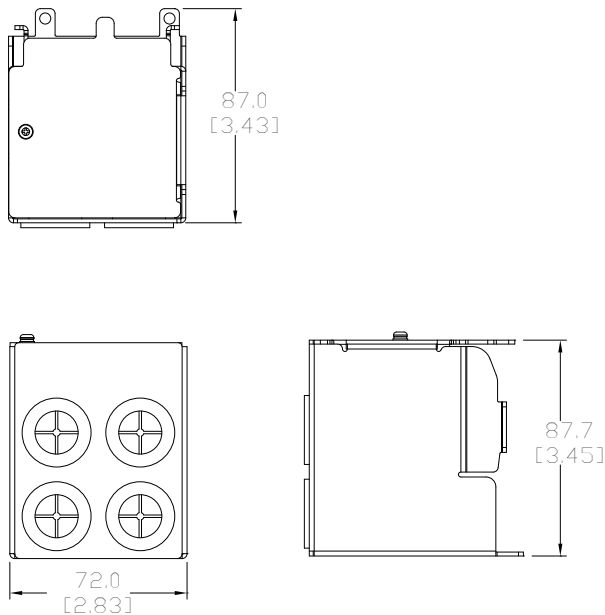

**DIMENSIONS (Units = mm [in])**

See our website [www.AutomationDirect.com](http://www.AutomationDirect.com) for complete engineering drawings and 3D models.

**GS30 FRAME SIZE C**

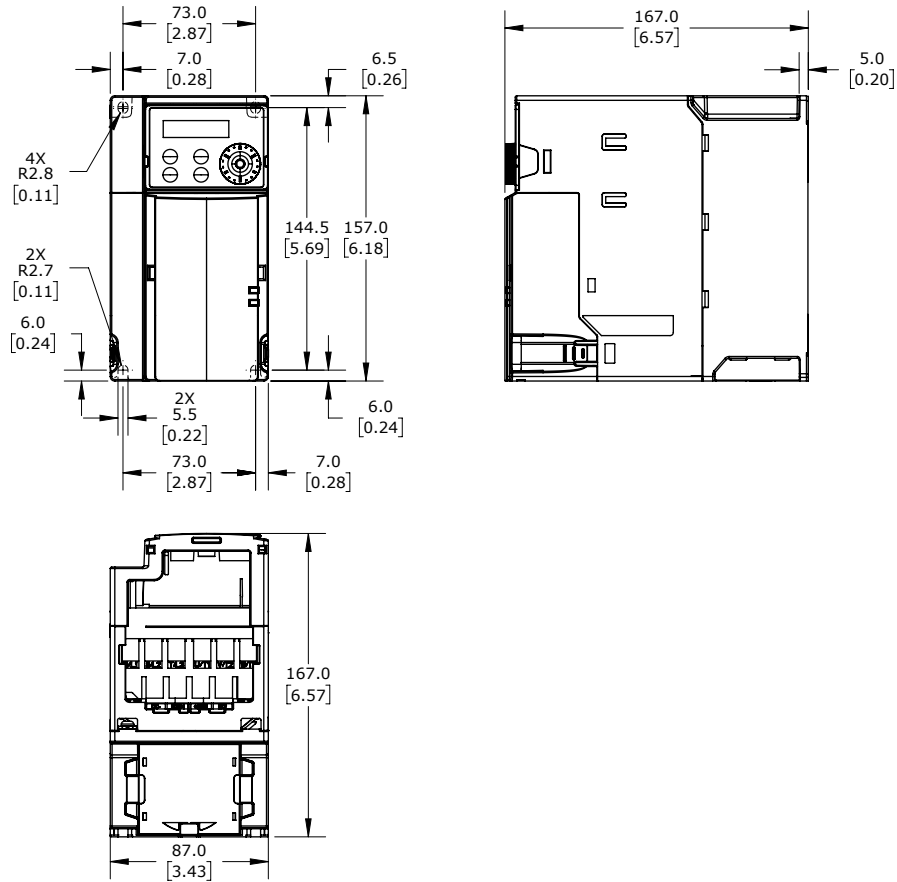

**GS30 FRAME SIZE C CONDUIT BOX**

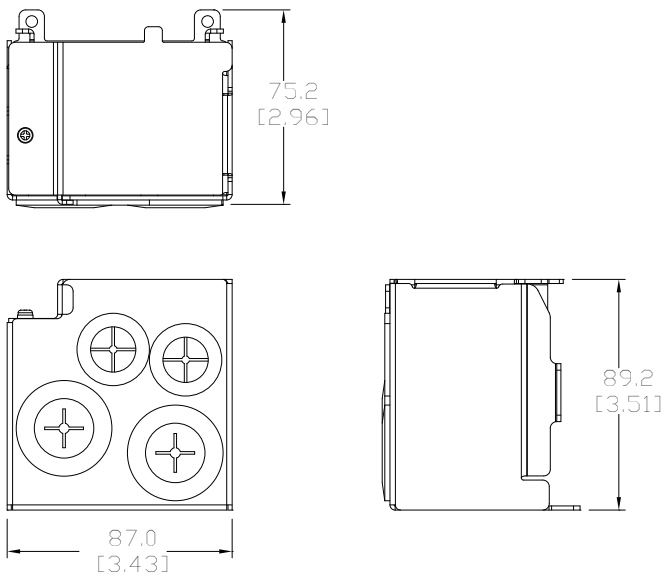



**DIMENSIONS (Units = mm [in])**

See our website [www.AutomationDirect.com](http://www.AutomationDirect.com) for complete engineering drawings and 3D models.

**GS30 FRAME SIZE D**

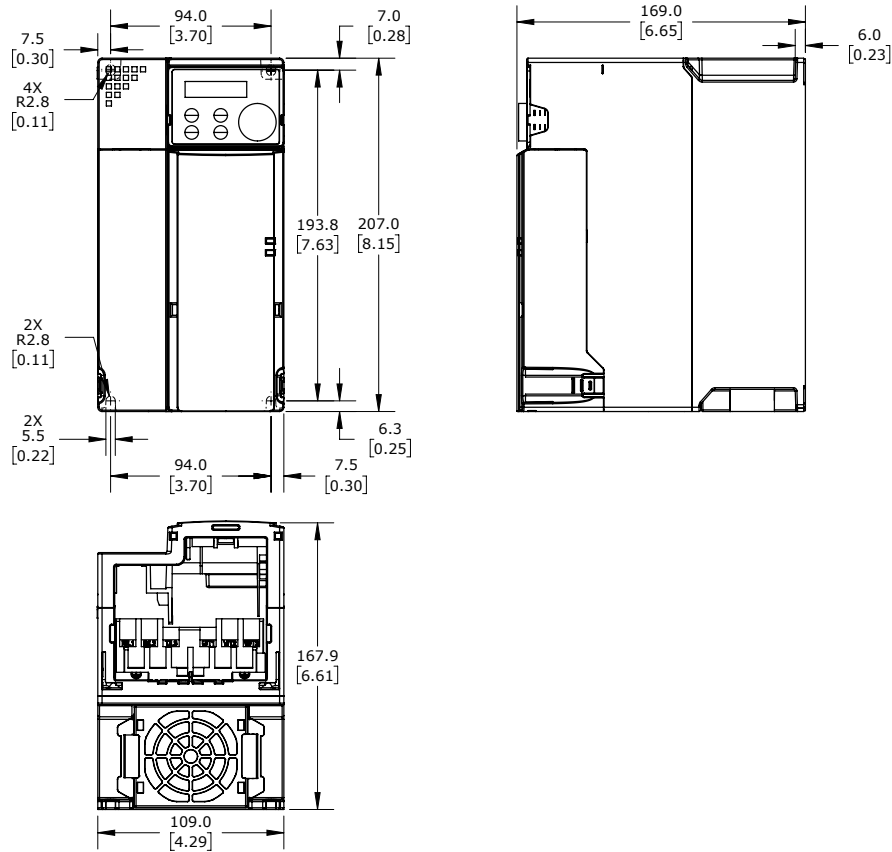

**GS30 FRAME SIZE D CONDUIT BOX**

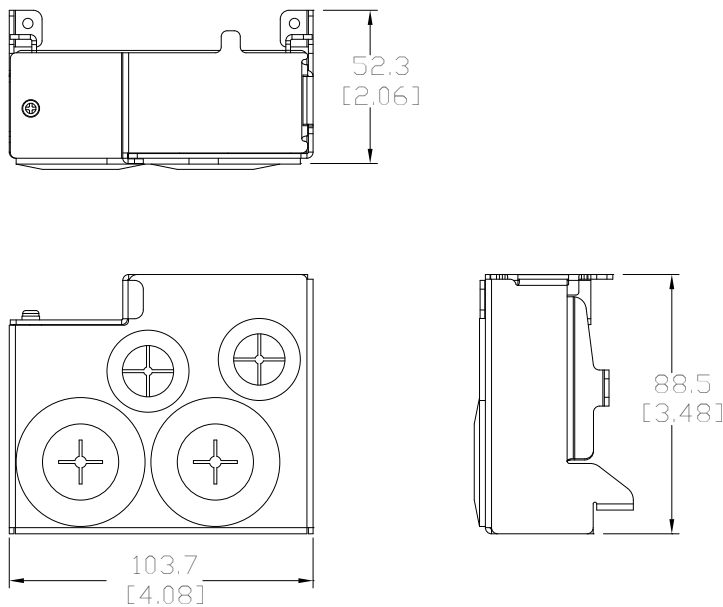

**DIMENSIONS (Units = mm [in])**

See our website [www.AutomationDirect.com](http://www.AutomationDirect.com) for complete engineering drawings and 3D models.

**GS30 FRAME SIZE E**

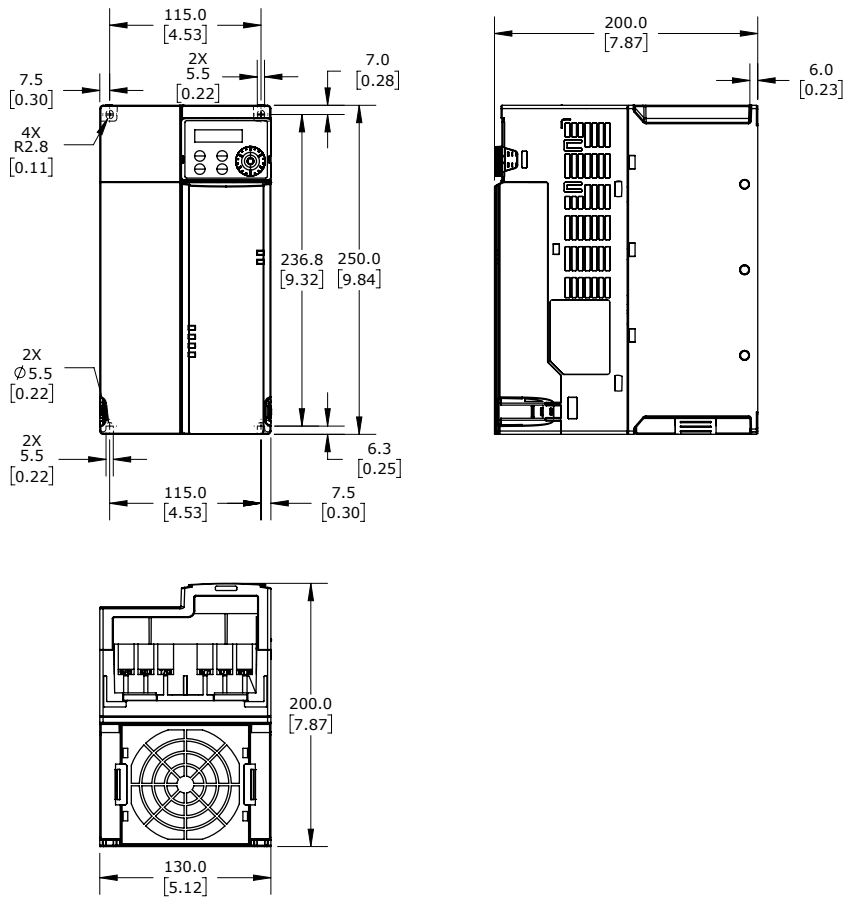

**GS30 FRAME SIZE E CONDUIT BOX**

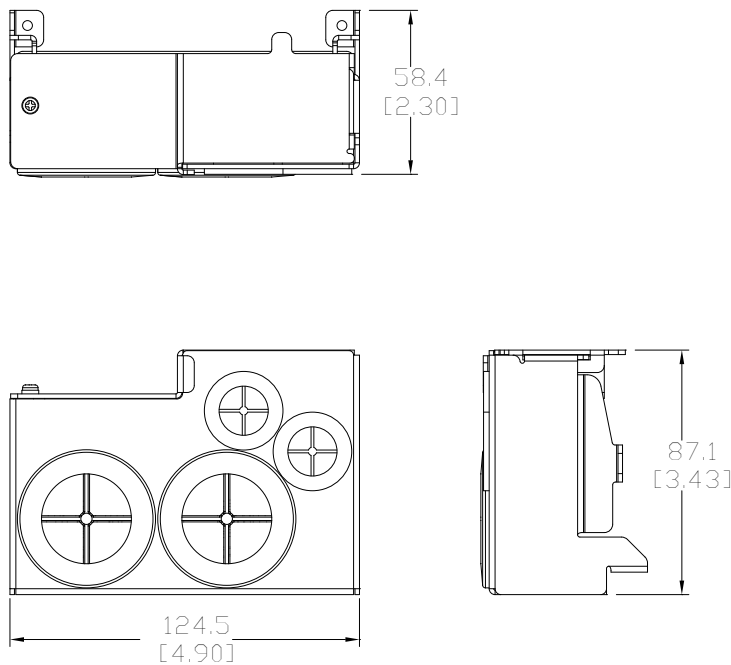

**DIMENSIONS (Units = mm [in])**

See our website [www.AutomationDirect.com](http://www.AutomationDirect.com) for complete engineering drawings and 3D models.

**GS30 FRAME SIZE F**

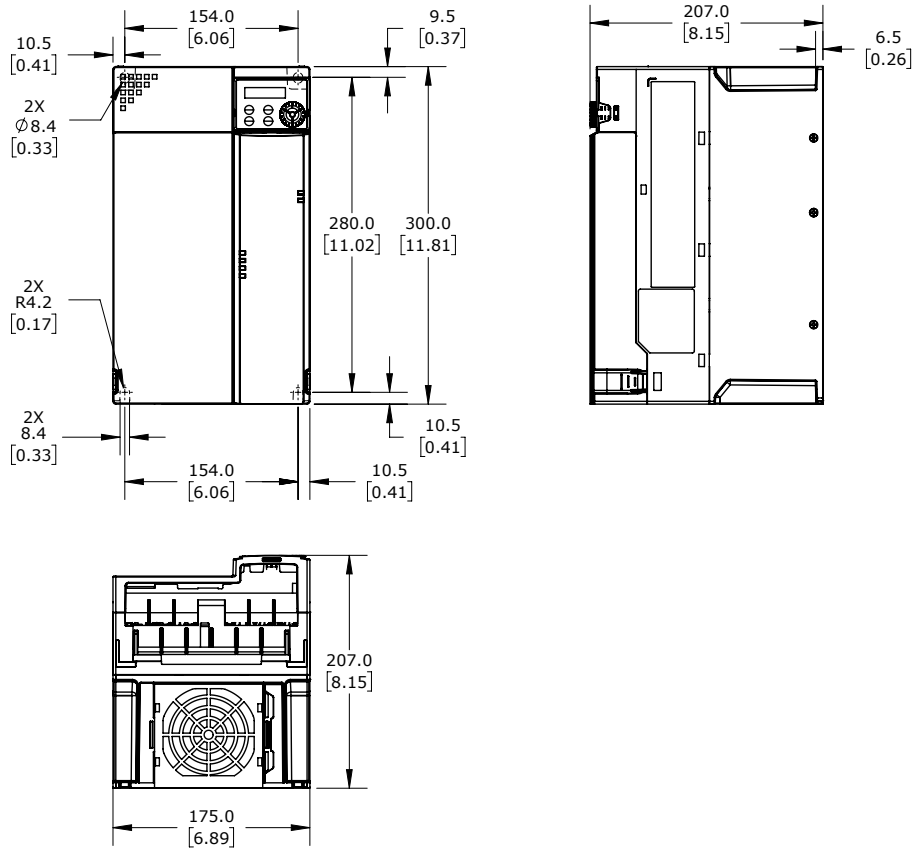

**GS30 FRAME SIZE F CONDUIT BOX**

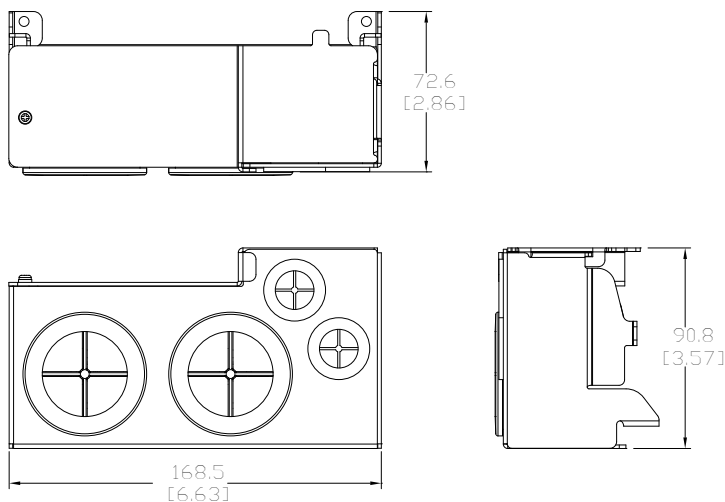

**DIMENSIONS (Units = mm [in])**

See our website [www.AutomationDirect.com](http://www.AutomationDirect.com) for complete engineering drawings and 3D models.

**GS30 FRAME SIZE G**

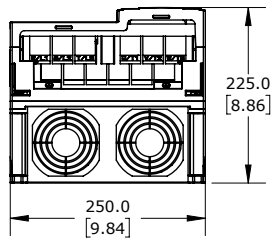
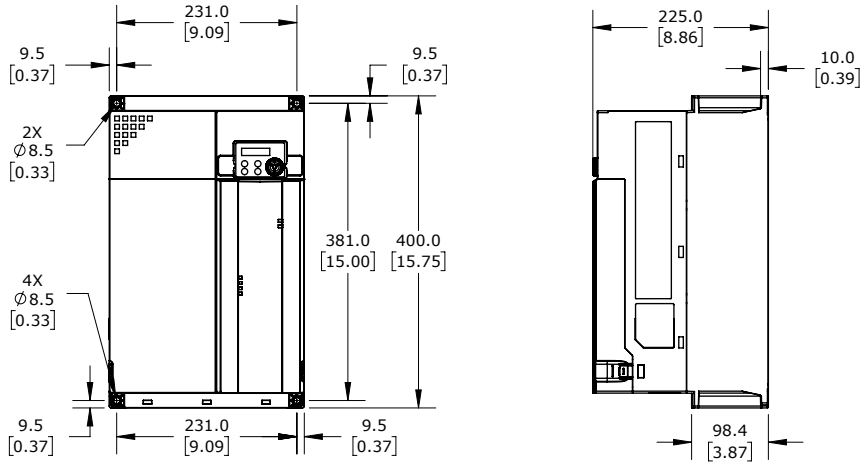

**GS30 FRAME SIZE G CONDUIT BOX**

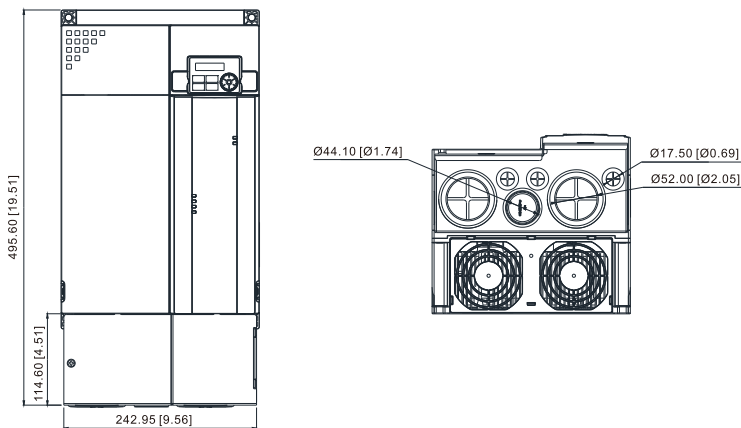

**DIMENSIONS (Units = mm [in])**

See our website [www.AutomationDirect.com](http://www.AutomationDirect.com) for complete engineering drawings and 3D models.

**GS30 FRAME SIZE H**

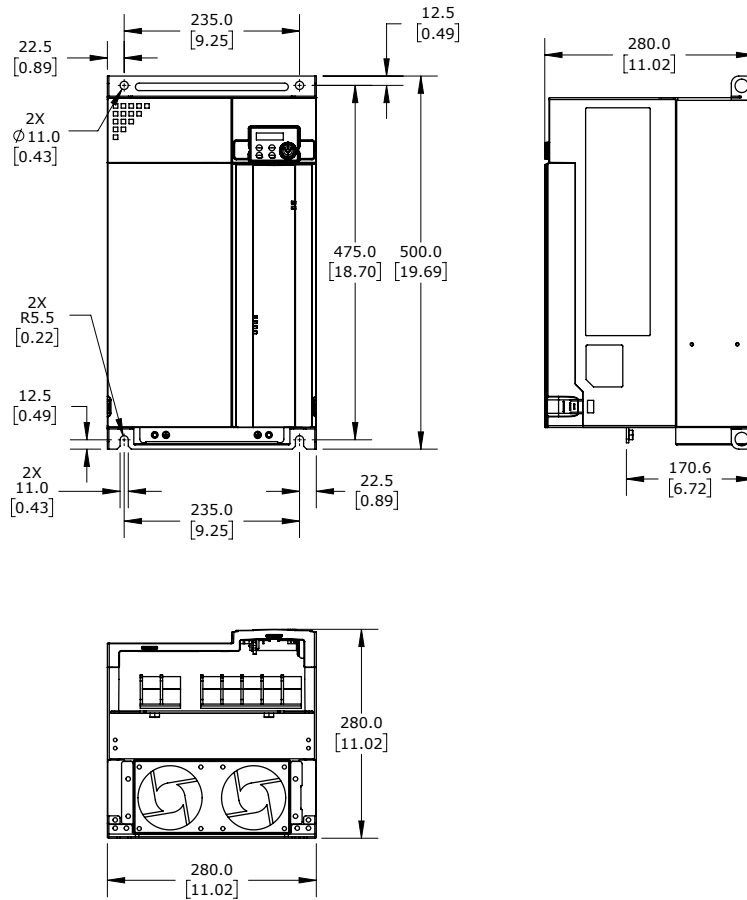

**GS30 FRAME SIZE H CONDUIT BOX**

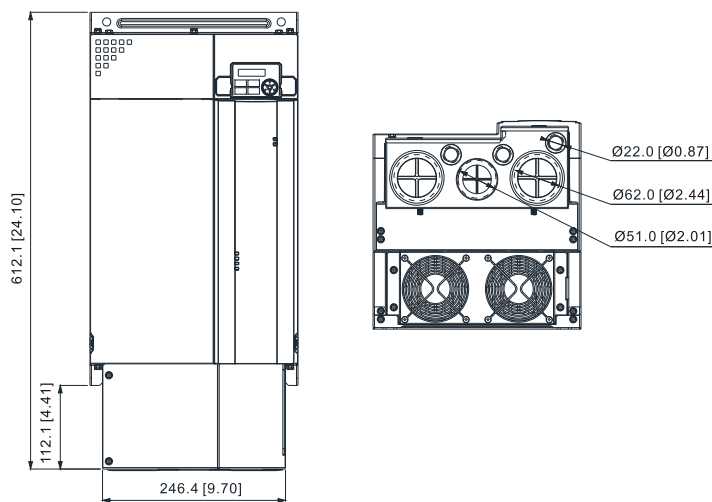

**DIMENSIONS (Units = mm [in])**

See our website [www.AutomationDirect.com](http://www.AutomationDirect.com) for complete engineering drawings and 3D models.

**GS30 FRAME SIZE I**

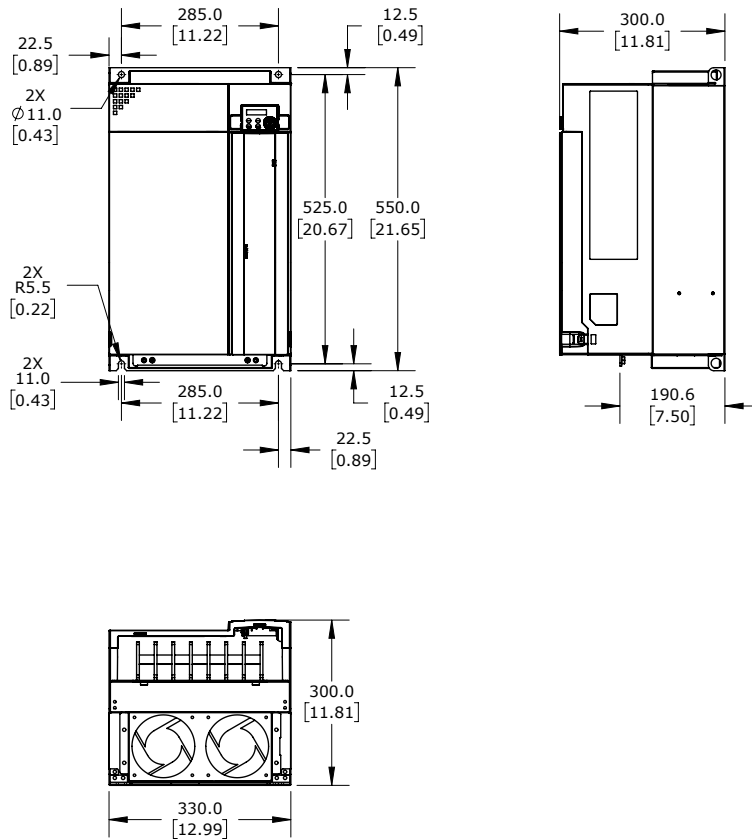

**GS30 FRAME SIZE I CONDUIT BOX**

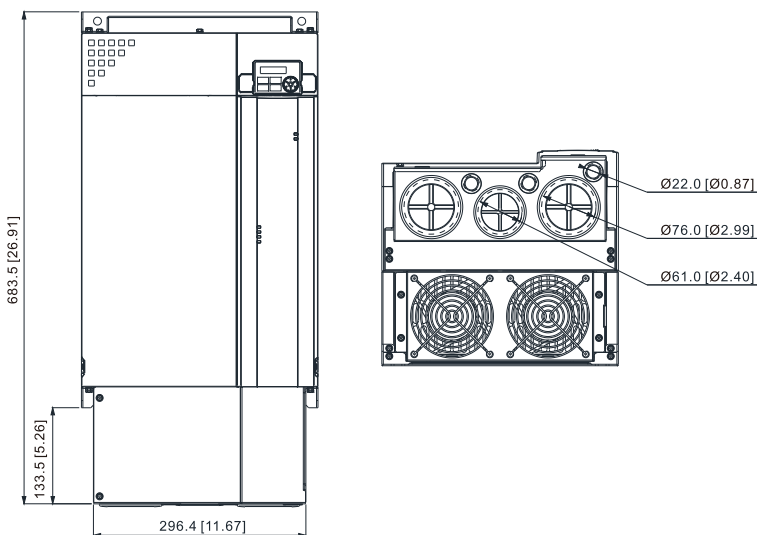

## CIRCUIT CONNECTIONS – RFI JUMPER

**RFI Jumper:** The GS30 drives may emit electrical noise. The drive contains Varistors / MOVs that are connected from phase to phase and from phase to ground to prevent the drive from unexpected stop or damage caused by mains surges or voltage spikes. Because the Varistors/ MOVs from phase to ground are connected to ground with the RFI jumper, removing the RFI jumper disables the protection.

### RFI JUMPER REMOVAL

The RFI jumper may need to be removed in some cases, such as situations in which the GS30 drive is powered from an Asymmetric Ground System (Corner Grounded TN System), as described on [page 2-17](#).

#### GS30 FRAMES A~I

Screw Torque: 4–6 kg·cm [3.5–5.2 lb·in]

Loosen the screw indicated in the view below, and remove the RFI jumper. Tighten the screw to the specified torque after the RFI jumper is removed.

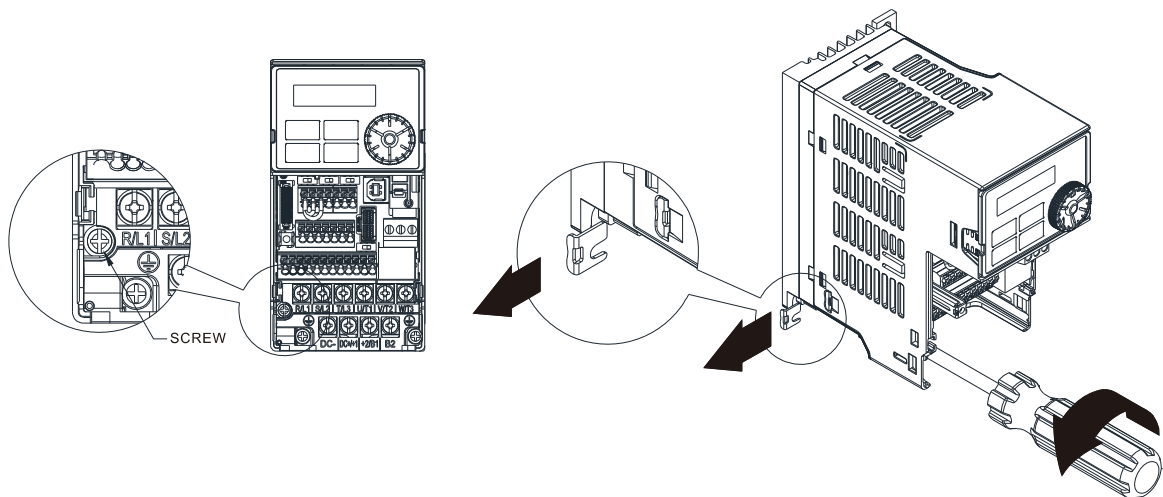

**ISOLATING MAIN POWER FROM GROUND**



**WARNING:** IF THE POWER DISTRIBUTION SYSTEM SUPPLYING THE GS30 DRIVE IS A FLOATING-GROUND SYSTEM (IT) OR AN ASYMMETRIC-GROUND SYSTEM (TN), THE RFI JUMPER MUST BE REMOVED.

If the power distribution system supplying the GS30 drive is a floating ground system (IT) or an asymmetric ground system (TN), the RFI jumper must be removed. Removing the RFI jumper disconnects the internal RFI filter capacitor between the drive’s frame and circuits to avoid damaging those circuits and to reduce ground leakage current.

**Important points regarding ground connection**

- To ensure the safety of personnel and proper operation, and to reduce electromagnetic radiation, the GS30 drive must be properly grounded during installation.
- The diameter of the cables must meet the size specified by applicable codes and regulations.
- The shield of shielded cables must be connected to the ground of the GS30 drive to meet safety regulations.
- The shield of shielded cables can be used as the ground for equipment *only when the aforementioned points are met.*
- When installing multiple GS30 drives, do not connect the grounds of the AC motor drive in series. Instead, use a single-point grounding scheme (as shown below) or provide individual grounding rods for each GS30 drive.

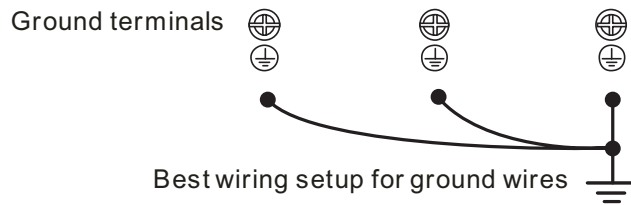

**Pay particular attention to the following WARNINGS:**



**WARNING:** DO NOT REMOVE THE RFI JUMPER WHILE POWER IS APPLIED TO THE GS30 DRIVE.



**WARNING:** REMOVING THE RFI JUMPER ALSO DISCONNECTS THE BUILT-IN EMC FILTER CAPACITORS. COMPLIANCE WITH THE EMC SPECIFICATIONS IS NO LONGER GUARANTEED.



**WARNING:** THE RFI JUMPER MAY NOT BE REMOVED IF THE MAIN POWER IS A SYMMETRICALLY GROUNDED POWER SYSTEM.



**WARNING:** DO NOT REMOVE THE RFI JUMPER WHILE CONDUCTING HIGH VOLTAGE TESTS. WHEN CONDUCTING A HIGH VOLTAGE TEST TO THE ENTIRE FACILITY, YOU MUST DISCONNECT THE MAINS POWER AND THE MOTOR IF THE LEAKAGE CURRENT IS TOO HIGH.



**FLOATING GROUND SYSTEM (IT SYSTEMS)**

A floating ground system is also called an IT system, an ungrounded system, or a high impedance/resistance grounding system (greater than 30Ω).

**Disconnect the RFI Jumper**



**CAUTION:** DO NOT INSTALL AN EXTERNAL RFI/EMC FILTER! THE EMC FILTER WILL PASS THROUGH THE RFI CAPACITOR, THUS CONNECTING POWER INPUT TO GROUND. THIS IS VERY DANGEROUS AND CAN EASILY DAMAGE THE GS30 DRIVE.

**ASYMMETRIC GROUND SYSTEM (CORNER GROUNDED TN SYSTEMS)**



**CAUTION:** DO NOT REMOVE THE RFI JUMPER WHILE THE INPUT TERMINALS OF THE GS30 DRIVE CARRIES POWER.

**The RFI jumper must be removed in the following four situations.** This is to prevent the system from grounding through the RFI capacitor, damaging the GS30 drive.

<b>RFI Jumper Must Be Removed (Asymmetric Ground / Corner Grounded TN Systems)</b>	
<p>1) Grounding at a Corner of a Triangle Configuration</p>	<p>2) Grounding at a Midpoint in a Polygonal Configuration</p>
<p>3) Grounding at One End in a Single-Phase Configuration</p>	<p>4) No Stable Neutral Grounding in a Three-Phase Autotransformer Configuration</p>

The RFI jumper should be left in place for a symmetrically grounded system.

<b>RFI Jumper Left In Place (Symmetrical Ground System)</b>	
<p>Internal grounding through internal RFI filter which reduces electromagnetic radiation.</p> <p>In a situation with higher requirements for electromagnetic compatibility, and using a symmetrical grounding power system, an EMC filter can be installed.</p> <p>As a reference, the diagram on the right is a symmetrical grounding power system.</p>	

## CIRCUIT CONNECTIONS – WARNINGS AND NOTES

**DANGER!**

**HAZARDOUS VOLTAGE!** BEFORE MAKING ANY CONNECTION TO THE AC DRIVE, DISCONNECT ALL POWER TO THE AC DRIVE, AND WAIT FIVE MINUTES FOR DC BUS CAPACITORS TO DISCHARGE.



**WARNING:** ANY ELECTRICAL OR MECHANICAL MODIFICATION TO THIS EQUIPMENT WILL VOID ALL WARRANTIES, MAY RESULT IN A SAFETY HAZARD, AND MAY VOID THE UL AND OTHER LISTINGS.



**WARNING:** DO NOT CONNECT THE AC INPUT POWER TO THE T1, T2, AND T3 OUTPUT TERMINALS. DOING THIS WILL DAMAGE THE AC DRIVE.



**WARNING:** DO NOT CONNECT SINGLE-PHASE POWER TO A THREE-PHASE DRIVE MODEL.



**WARNING:** TIGHTEN ALL SCREWS TO THE PROPER TORQUE RATING. SEE “MAIN CIRCUIT WIRING” LATER IN THIS CHAPTER.

**WIRING NOTES: PLEASE READ PRIOR TO INSTALLATION.**

- 1) During installation, follow all local electrical, construction, and safety codes for the country in which the AC drive is to be installed.
- 2) Refer to the “DURAPULSE GS30 Drive Specifications” in chapter 1 for voltage and current requirements.
- 3) Torque the screws of the main circuit terminals to prevent loosening due to vibration.
- 4) The addition of a magnetic contactor (MC) in the AC line power input wiring is recommended to turn off power quickly and reduce the possibility of malfunction if the protection function of the GS30 AC drive is activated. AutomationDirect recommends using a suppressor on the MC coil.
- 5) Do not use a power circuit contactor or disconnect switch for normal run/stop control of the GS30 AC drive and motor. This will reduce the operating life cycle of the AC drive. Cycling a power circuit switching device while the AC drive is in run mode should be done only in emergency situations.
- 6) Make sure the appropriate protective devices (circuit breaker or fuses) are connected between the power supply and AC drive.
- 7) Make sure that the leads are connected correctly and that the GS30 AC drive is properly grounded. Ground resistance should not exceed  $0.1\Omega$ .
- 8) Use ground leads that comply with AWG/MCM standards and keep them as short as possible.
- 9) Multiple GS30 AC drives can be installed in one location. All of the units should be grounded directly to a common ground terminal. The GS30 AC drive ground terminals may also be connected in parallel, as shown in the figure below.

**Make sure there are no ground loops.**

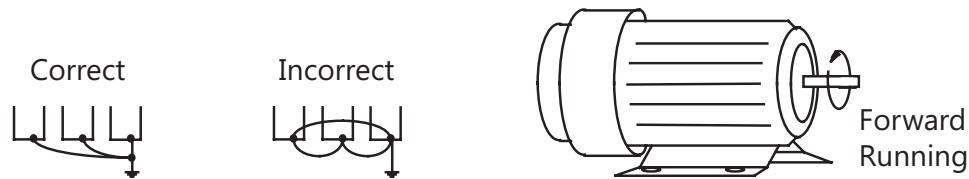

- 10) When the GS30 AC drive output terminals T1, T2, and T3 are connected to the motor terminals T1, T2, and T3, respectively, the motor will rotate counterclockwise (as viewed from the shaft end of the motor) when a forward operation command is received. To reverse the direction of motor rotation, switch the connections of any of the two motor leads.
- 11) Make sure that the power source is capable of supplying the correct voltage and required current to the GS30 AC drive.
- 12) Do not attach or remove wiring when power is applied to the GS30 AC drive.
- 13) Do not inspect components until at least 5 minutes has passed from when the drive supply power was disconnected, to allow the drive capacitors to drain.
- 14) Do not access or remove any of the covers when the drive is powered.

- 15) Route the power, communication, and control wires separately, or at 90 degree angle to each other.
- 16) Ground both ends of the shield wire or conduit for the power wiring.
  - a) If using a “VFD cable,” follow the manufacturer’s recommendation for grounding the cable shield.
  - b) If using conduit, bond and ground conduit according to applicable electrical codes.
- 17) If a filter is required for reducing EMI (Electro Magnetic Interference), install it as close as possible to the GS30 AC drive input. EMI can also be reduced by lowering the Carrier Frequency. Please refer to the “Applied EMI/RFI Techniques” white paper at [support.automationdirect.com](http://support.automationdirect.com).
- 18) If the GS30 AC drive is installed in a place where a load reactor is needed, install the reactor close to the T1, T2, and T3 side of GS30 AC drive. Do not use a Capacitor, L-C Filter (Inductance-Capacitance), or R-C Filter (Resistance-Capacitance).
- 19) When using a GFCI (Ground Fault Circuit Interrupt), select current sensor with sensitivity of 200mA or higher, and not less than 0.1-second operation time to avoid nuisance tripping.

**MAIN POWER TERMINALS**

- Do not supply any GS33-xxxx models with single-phase power.
- R/L1, S/L2, and T/L3 have no phase-sequence requirement; they can be wired in any order.
- Do NOT start/stop the GS30 AC drive by turning input power ON/OFF except in emergencies.
- Start/stop the GS30 AC drive using RUN/STOP commands via control terminals or the keypad. If you must start/stop the GS30 AC drive by turning power ON/OFF, it is recommended to do so only ONCE per hour.

**OUTPUT TERMINALS FOR MAIN CIRCUIT**

- Do NOT connect phase-compensation capacitors or surge absorbers to the output terminals of the GS30 AC drive.
- Use a well-insulated motor rated for inverter operation.

**TERMINALS FOR CONNECTING DC REACTOR, EXTERNAL BRAKE RESISTOR, AND DC CIRCUIT**

- Terminals +1 and +2 are used to connect an optional DC reactor or choke to improve power factor. From the factory, these terminals are connected with a short-circuit jumper. Remove this jumper before connecting a DC reactor.
- Leave the jumper in place **IF** a DC reactor is not connected **AND** DC+ / +1 and +2/B1 terminals are used for common DC bus or brake resistors. This will prevent the AC motor drive from losing power and damage to the terminals. If the jumper is missing due to wiring, refer to the recommended main circuit terminal wire to short-circuit the DC+ / +1 and +2/B1 terminals.

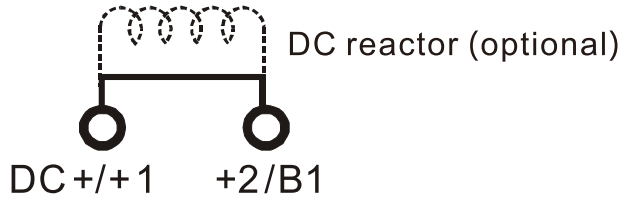

- When the GS30 AC Drive is connected directly to a large-capacity power transformer (600kVA or above) or when a phase lead capacitor is switched, peak currents may occur in the power input circuit due to the load change. This can result in damage to the converter section of the drive. To avoid this damage install a line reactor at the GS30 input terminals, R/L1, S/L2, and T/L3. The installation of a line reactor will reduce current spikes and improve input power efficiency.
- Install an external brake resistor for applications that include frequent deceleration to stop, short deceleration time (such as high frequency operation and heavy load operation), too low braking torque, or increased braking torque.

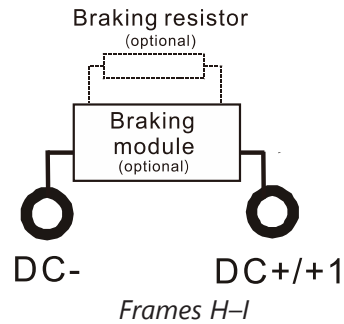
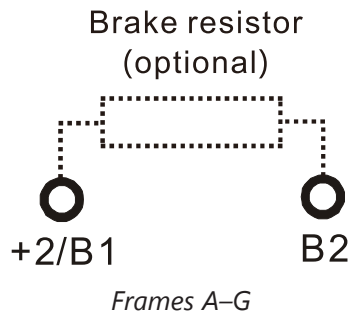

- For GS30 drives, the external brake resistor should be connected to the B1 and B2 terminals for frame sizes A through G. On frames H & I, braking resistors must be connected to a dynamic braking unit and not directly to the drive. See diagram above for reference.
- If the terminals [+1], [+2], and [DC-] are not used, leave these three terminals open.
- To avoid personal injury and to prevent damage to the GS30 drive; **DO NOT** jumper DC- to DC+, DC- to +2/B1, DC- to B2. Connect braking resistors to B1 and B2 **ONLY**
- DC+ and DC- are connected for common DC bus, please refer to "[Main Circuit Wiring Terminals](#)" in this chapter for wiring terminal specification and wire gauge information.
- Please refer to the DURAPULSE Drives Dynamic Braking User Manual for more information on installing brake units.  
(Available for free download at <http://www.automationdirect.com/static/manuals/index.html>.)

**MOTOR OPERATION PRECAUTIONS**

- 1) When using the GS30 AC drive to operate a non-inverter rated 3-phase induction motor, notice that the energy loss is greater than for an inverter rated motor.
- 2) Avoid running a non-inverter rated induction motor at low speed. Doing so may cause the motor temperature to exceed the motor rating due to limited airflow produced by the motor's fan.
- 3) When the non-inverter rated motor operates at low speed, the output load must be decreased.
- 4) If **100% output torque** is desired at low speed, it is necessary to use an inverter rated motor.

**SHORT CIRCUIT WITHSTAND (SCCR)**

All *DURAPULSE* GS30 series drives are suitable for use on a circuit capable of delivering not more than 100,000 rms symmetrical amperes.

**APPLICABLE CODES**

All *DURAPULSE* GS30 AC drives are Underwriters Laboratories, Inc. (UL) and Canadian Underwriters Laboratories (cUL) listed, and therefore comply with the requirements of the National Electrical Code (NEC) and the Canadian Electrical Code (CEC).

Installations intended to meet the UL and cUL requirements must follow the instructions provided in “Wiring Notes” as a minimum standard. Follow all local codes that exceed UL and cUL requirements. Refer to the technical data label affixed to the AC drive and the motor nameplate for electrical data.

The “Circuit Protection Devices” section in Appendix A lists the recommended fuse part number for each *DURAPULSE* part number. These fuses (or equivalent) must be used on all installations where compliance with UL standards is required.

## WIRING TERMINAL ACCESS

### CONTROL TERMINAL ACCESS

Remove the drive front cover to access and wire the multi-function input/output control terminals.

#### GS30 DRIVE FRAMES A ~ I

Press the tabs on both sides to remove the cover (Frame A example shown below).

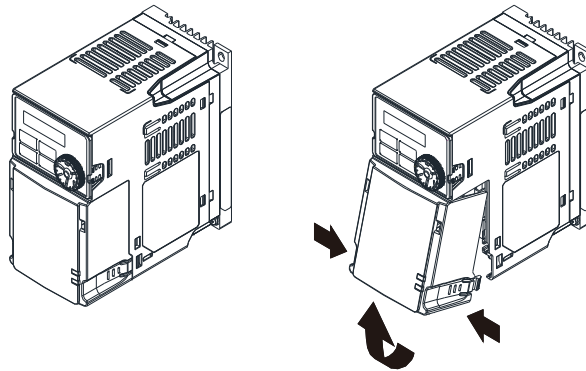

Press the clip on both sides, and take out the front cover by rotating.

## MAIN CIRCUIT WIRING TERMINALS

### MAIN TERMINAL SPECIFICATIONS

Main Circuit Terminals	
Terminal	Description
R/L1, S/L2	Input Power – 1-phase
R/L1, S/L2, T/L3	Input Power – 3-phase
U/T1, V/T2, W/T3	AC Motor Drive Output
+1, +2 <sup>1</sup>	Connection for DC reactor/choke (remove jumper before installing a DC reactor/choke)
B1, B2	Braking Resistor Connection (Frames A–G)
DC+, DC- <sup>1</sup>	Common DC Bus
	Ground

GS30 Main Circuit Wiring Specifications							
AC Drive Frame Size	AC Drive Model	Main Circuit Terminals R/L1, S/L2, T/L3, U/T1, V/T2, W/T3, DC-, DC+/ <sup>1</sup> +1, +2/B1, B2			Ground Terminals 		
		Max Wire Gauge	Min Wire Gauge	Screw Size & Torque (±10%)	Max Wire Gauge	Min Wire Gauge	Screw Size & Torque (±10%)
A	GS31-20P5	2.5 mm <sup>2</sup> [14 AWG]	2.5 mm <sup>2</sup>	M3.5 9 kg-cm [7.8 in-lb] [0.88 N·m]	2.5 mm <sup>2</sup> [14 AWG]	2.5 mm <sup>2</sup> [14 AWG]	M3.5 9 kg-cm [7.8 in-lb] [0.88 N·m]
	GS33-21P0		[14 AWG]				
	GS33-20P5		0.75 mm <sup>2</sup>				
	GS33-40P5		[18 AWG]				
	GS33-41P0		1.5 mm <sup>2</sup> [16 AWG]				
B	GS31-21P0	4 mm <sup>2</sup> [12 AWG]	4 mm <sup>2</sup>	M4 15 kg-cm [13.0 in-lb] [1.47 N·m]	4 mm <sup>2</sup> [12 AWG]	4 mm <sup>2</sup> [12 AWG]	M4 15 kg-cm [13.0 in-lb] [1.47 N·m]
	GS33-22P0		[12 AWG]				
	GS33-42P0		2.5 mm <sup>2</sup> [14 AWG]				
C	GS31-22P0	10 mm <sup>2</sup> [8 AWG]	10 mm <sup>2</sup>	M4 20 kg-cm [17.4 in-lb] [1.96 N·m]	10 mm <sup>2</sup> [8 AWG]	10 mm <sup>2</sup> [8 AWG]	M4 20 kg-cm [17.4 in-lb] [1.96 N·m]
	GS31-23P0		[8 AWG]				
	GS33-25P0		6 mm <sup>2</sup>				
	GS33-23P0		[10 AWG]				
	GS33-43P0		2.5 mm <sup>2</sup> [14 AWG]				
	GS33-45P0		4 mm <sup>2</sup> [12 AWG]				
D	GS33-27P5	10 mm <sup>2</sup> [8 AWG]	10 mm <sup>2</sup>	M4 20 kg-cm [17.4 in-lb] [1.96 N·m]	10 mm <sup>2</sup> [8 AWG]	10 mm <sup>2</sup> [8 AWG]	M4 20 kg-cm [17.4 in-lb] [1.96 N·m]
	GS33-4010		[8 AWG]				
	GS33-47P5		6 mm <sup>2</sup> [10 AWG]				
E	GS33-2010	16 mm <sup>2</sup> [6 AWG]	16 mm <sup>2</sup>	M5 25 kg-cm [21.7 in-lb] [2.45 N·m]	16 mm <sup>2</sup> [6 AWG]	16 mm <sup>2</sup> [6 AWG]	M5 25 kg-cm [21.7 in-lb] [2.45 N·m]
	GS33-4015		[6 AWG]				
	GS33-4020	25 mm <sup>2</sup>					
	GS33-2015	[4 AWG]					
F	GS33-2020	35 mm <sup>2</sup> [2 AWG]	35 mm <sup>2</sup>	M6 40 kg-cm [34.7 in-lb] [3.92 N·m]	35 mm <sup>2</sup> [2 AWG]	16 mm <sup>2</sup> [6 AWG]	M6 40 kg-cm [34.7 in-lb] [3.92 N·m]
	GS33-4030		[2 AWG]				
	GS33-4025		25 mm <sup>2</sup> [4 AWG]				
G	GS33-2025	50 mm <sup>2</sup> [1/0 AWG]	35 mm <sup>2</sup>	M8 80 kg-cm [69.4 in-lb] [7.84 N·m]	35 mm <sup>2</sup>	16 mm <sup>2</sup> [6 AWG]	M8 80 kg-cm [69.4 in-lb] [7.84 N·m]
	GS33-2030		[2 AWG]				
	GS33-4040		25 mm <sup>2</sup> [4 AWG]				

\* Wiring specifications for drives with optional conduit box

(continued next page)

Main Circuit Wiring Specifications (continued)							
AC Drive Frame Size	AC Drive Model	Main Circuit Terminals R/L1, S/L2, T/L3, U/T1, V/T2, W/T3, DC-, DC+ / +1, +2/B1, B2			Ground Terminals $\oplus$		
		Max Wire Gauge	Min Wire Gauge	Screw Size & Torque ( $\pm 10\%$ )	Max Wire Gauge	Min Wire Gauge	Screw Size & Torque ( $\pm 10\%$ )
H	GS33-4050	95 mm <sup>2</sup> [3/0 AWG]	50 mm <sup>2</sup> [1/0 AWG]	M8 80 kg-cm [69.4 in-lb] [7.84 N·m]	95 mm <sup>2</sup> [3/0 AWG]	25 mm <sup>2</sup> [4 AWG]	M8 80 kg-cm [69.4 in-lb] [7.84 N·m]
	GS33-4060		95 mm <sup>2</sup> [3/0 AWG]	50 mm <sup>2</sup> [1/0 AWG]		50 mm <sup>2</sup> [1/0 AWG]	
H*	GS33-4050	70 mm <sup>2</sup> [2/0 AWG]	50 mm <sup>2</sup> [1/0 AWG]	M8 80 kg-cm [69.4 in-lb] [7.84 N·m]	70 mm <sup>2</sup> [2/0 AWG]	25 mm <sup>2</sup> [4 AWG]	M8 80 kg-cm [69.4 in-lb] [7.84 N·m]
	GS33-4060		70 mm <sup>2</sup> [2/0 AWG]	70 mm <sup>2</sup> [2/0 AWG]		35 mm <sup>2</sup> [2 AWG]	
I	GS33-2040	150 mm <sup>2</sup> [300MCM]	150 mm <sup>2</sup> [250MCM]	M8 80 kg-cm [69.4 in-lb] [7.84 N·m]	150 mm <sup>2</sup> [300MCM]	95 mm <sup>2</sup> [3/0 AWG]	M8 80 kg-cm [69.4 in-lb] [7.84 N·m]
	GS33-2050		150 mm <sup>2</sup> [300MCM]				
	GS33-4100		120 mm <sup>2</sup> [4/0 AWG]			70 mm <sup>2</sup> [2/0 AWG]	
	GS33-4075		120 mm <sup>2</sup> [4/0 AWG]				
I*	GS33-2040	120 mm <sup>2</sup> [4/0 AWG]	95 mm <sup>2</sup> [3/0 AWG]	M8 80 kg-cm [69.4 in-lb] [7.84 N·m]	150 mm <sup>2</sup> [300MCM]	95 mm <sup>2</sup> [3/0 AWG]	M8 80 kg-cm [69.4 in-lb] [7.84 N·m]
	GS33-2050		120 mm <sup>2</sup> [4/0 AWG]				
	GS33-4100		95 mm <sup>2</sup> [3/0 AWG]			70 mm <sup>2</sup> [2/0 AWG]	
	GS33-4075		95 mm <sup>2</sup> [3/0 AWG]				

\* Wiring specifications for drives with optional conduit box



UL installations must use 600V, 75°C or 90°C wires. Use copper wire only.



**WIRING TERMINAL CONNECTOR DIMENSIONS – MAIN-CIRCUIT TERMINALS**

**GS30 DRIVES, FRAME SIZE A ~ I**

*NOTE:* Heat shrink should comply with UL (600V, YDPU2).

Dimensions = mm

**Power Terminal Wiring Connectors:**

**Heat Shrink Tubing:**

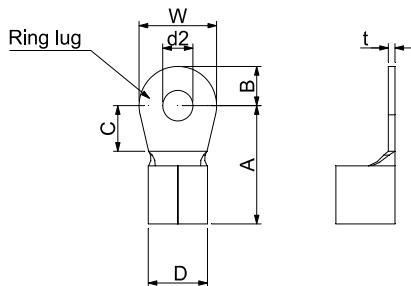

Figure 1.

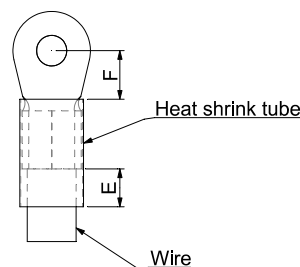
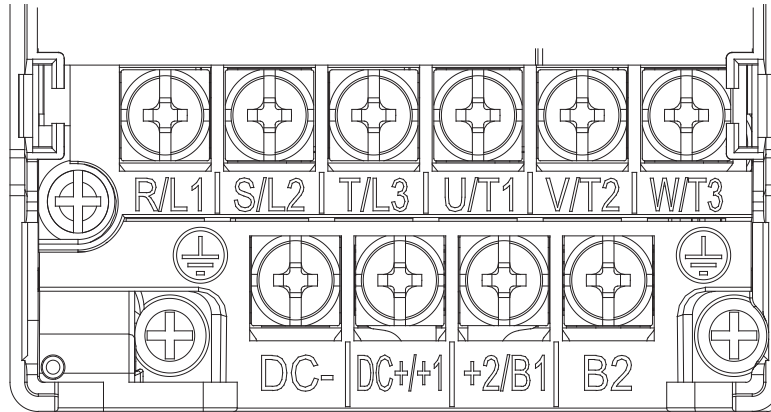

Figure 2.

GS30 Ring Lug Dimensions (mm)											
Frame	AWG	Part Number (Manuf: K.S. Terminals)	A (Max)	B (Max)	C (Min)	D (Max)	d2 (Min)	E (Min)	F (Min)	W (Max)	t (Max)
A	18	RNBS 1.3-7	9.8	3.2	4.8	4.1	3.7	13.0	4.2	6.6	0.8
	16	RNBS 2-3.7									
	14	RNBS 2-3.7									
B	18	RNBS1-4	12.1	3.6	6.1	5.6	4.3	13.0	4.5	7.2	1
	16	RNBS1-4									
	14	RNBS2-4									
C	12	RNBS5-4	17.8	5.0	6.1	7.2	4.3	13.0	5.5	10.5	1.2
	14	RNBS2-4									
	10	RNBS5-4									
D	10	RNBS5-4	17.8	5.0	6.1	7.2	4.3	13.0	5.5	10.5	1.2
	8	RNBS8-4									
E	6	RNBS8-4	27.1	6.1	10.5	11.5	5.3	13.0	6.5	12.6	1.7
	4	RNBS14-5									
F	6	RNBS14-6	35.0	9.0	13.3	14.0	6.2	13.0	10.0	19.5	1.8
	4	RNBS22-6									
	2	RNBS38-6									
G	6	RNBS14-8	38.7	12.0	13.5	17.5	8.4	13.0	13.0	24.0	1.8
	4	RNB22-8									
	2	RNBS38-8									
	1/0	RNB60-8									
H	4	RNB22-8	40.0	11.0	10.0	23.0	8.3	13.0	14.0	24.0	4.5
	2	RNBS38-8									
	1	SQNBS60-8									
	1/0	SQNBS60-8									
	2/0	SQNBS80-8									
I	3/0	SQNBS80-8	50.0	16.0	10.0	27.0	8.3	13.0	14.0	28.0	6.0
	1/0	RNB60-8									
	2/0	RNB70-8									
	3/0	RNB80-8									
	4/0	SQNBS100-8									
	250MCM	SQNBS150-8									
300MCM	SQNBS150-8										

**MAIN TERMINAL DIAGRAMS**

**GS30 FRAME SIZE A MAIN TERMINALS**



**GS30 FRAME SIZE B MAIN TERMINALS**

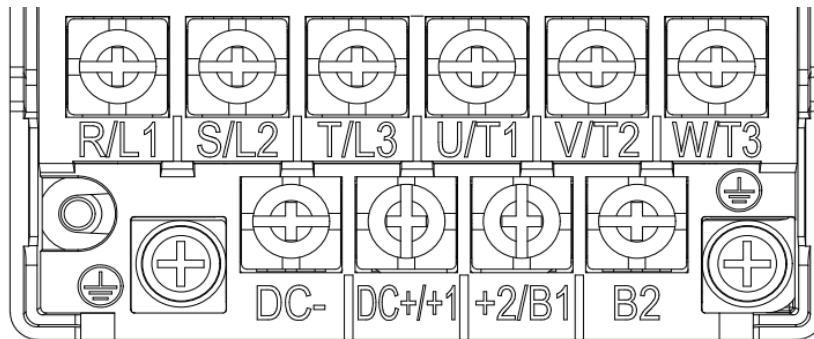

**GS30 FRAME SIZE C MAIN TERMINALS**

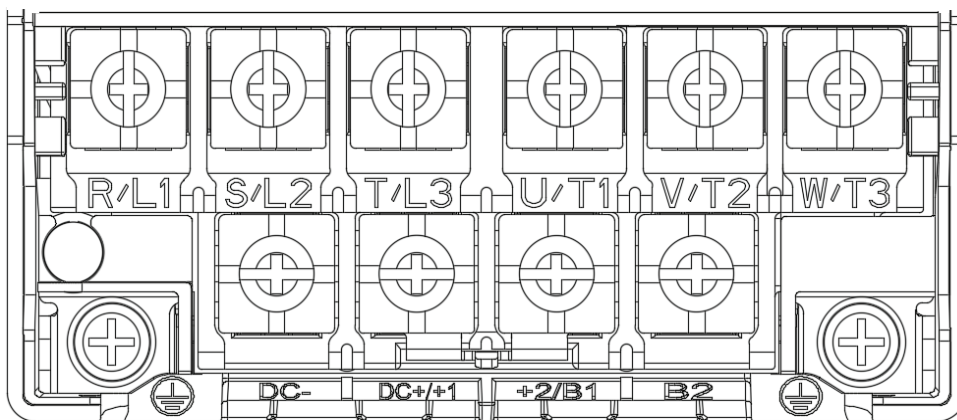

**MAIN TERMINAL DIAGRAMS (CONTINUED)**

**GS30 FRAME SIZE D MAIN TERMINALS**

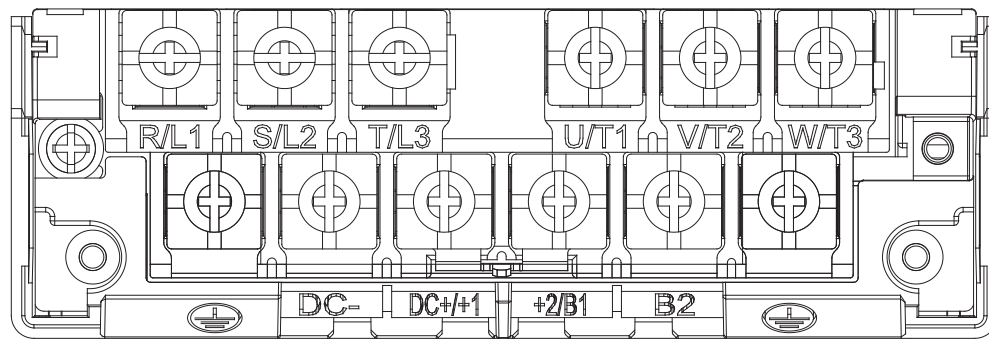

**GS30 FRAME SIZE E MAIN TERMINALS**

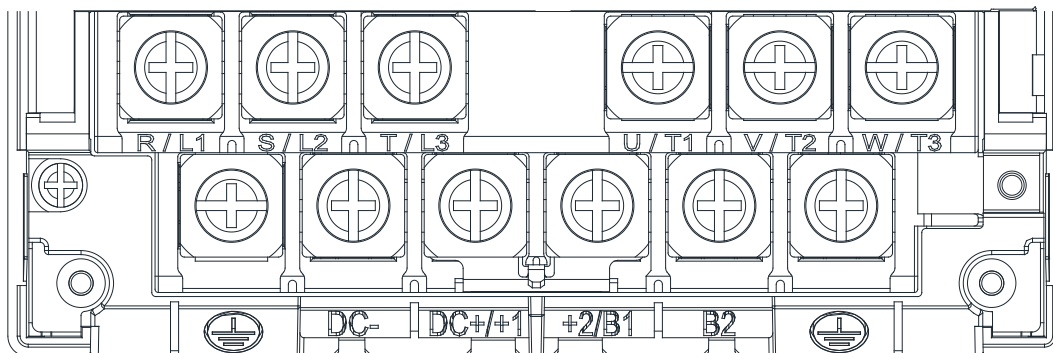

**GS30 FRAME SIZE F MAIN TERMINALS**

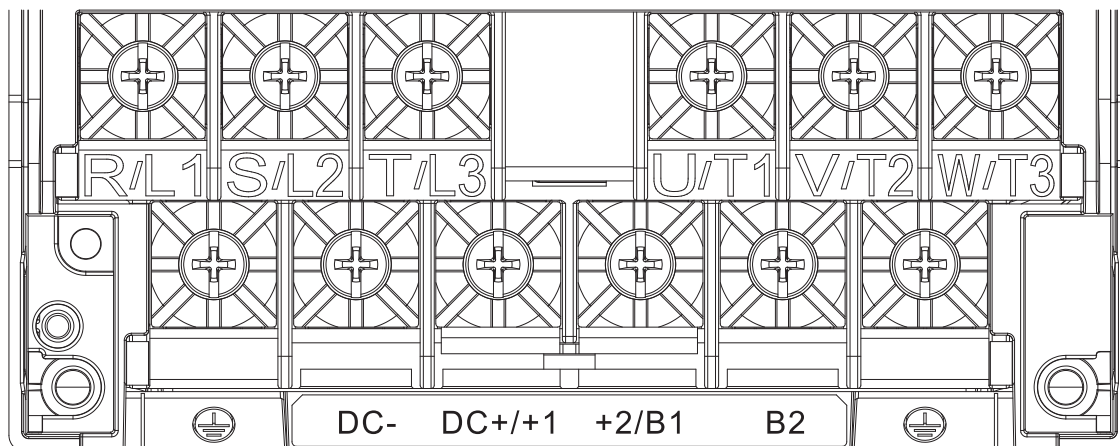

**MAIN TERMINAL DIAGRAMS (CONTINUED)**

**GS30 FRAME SIZE G MAIN TERMINALS**

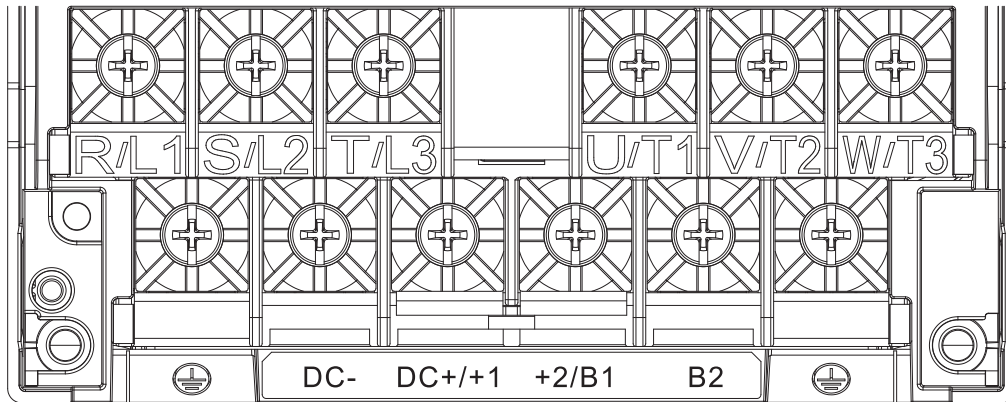

**GS30 FRAME SIZE H MAIN TERMINALS**

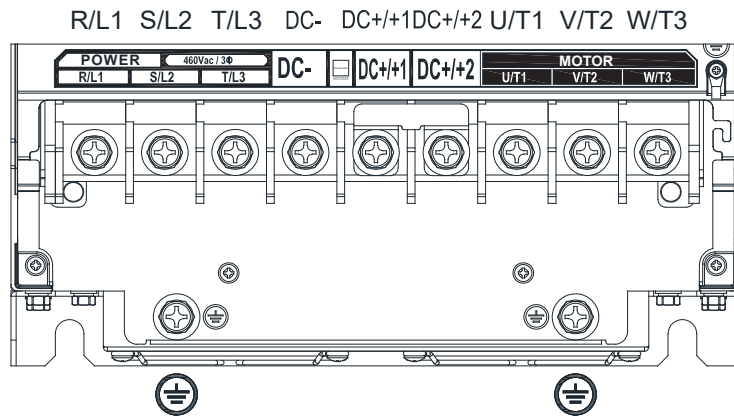

**GS30 FRAME SIZE I MAIN TERMINALS**

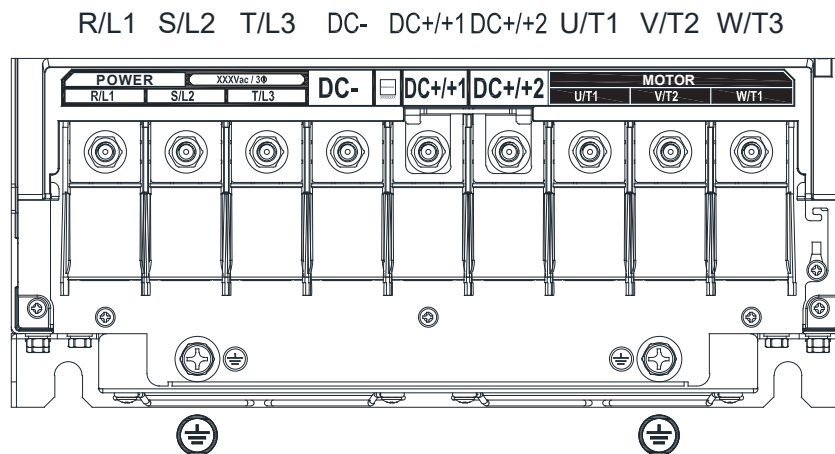

## MAIN CIRCUIT WIRING DIAGRAMS

### GS30 FRAME SIZES A-G

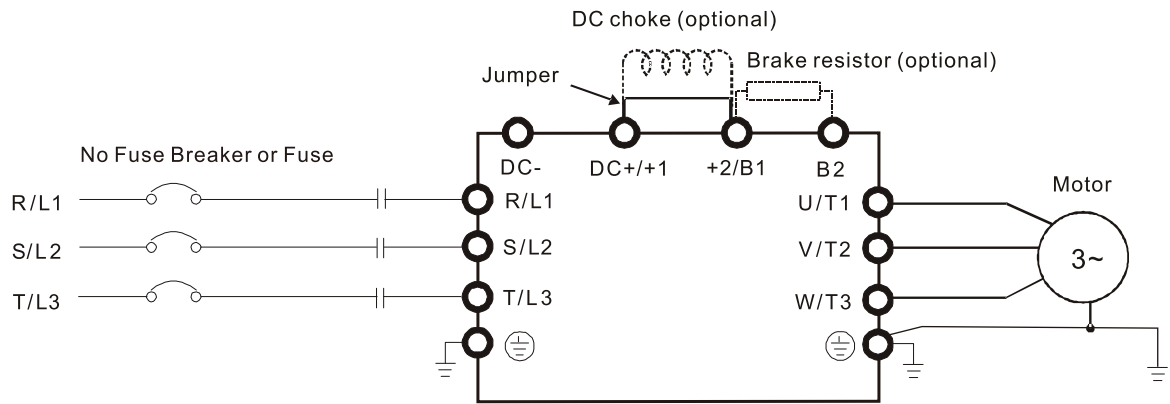

### GS30 FRAME SIZES H-I

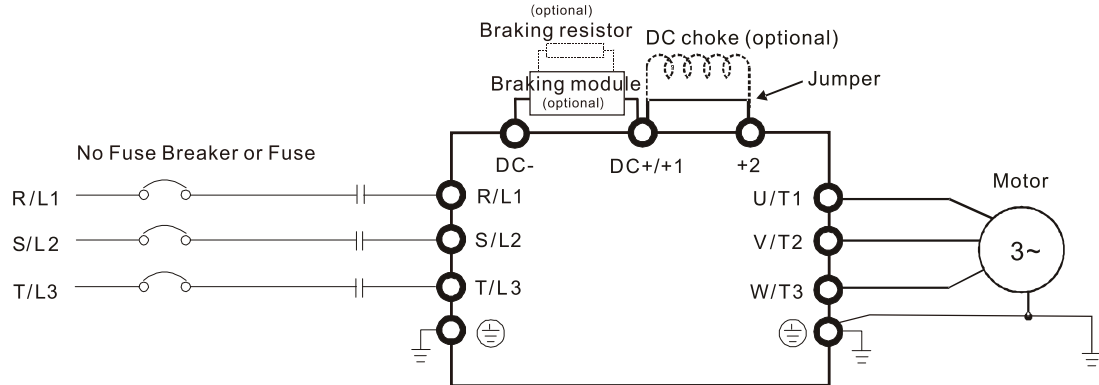

## CONTROL CIRCUIT WIRING TERMINALS

### GS30 CONTROL TERMINAL SPECIFICATIONS

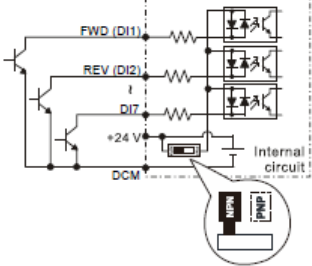
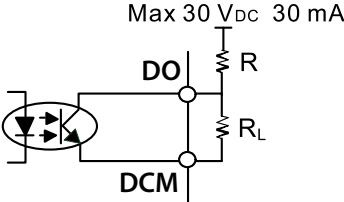
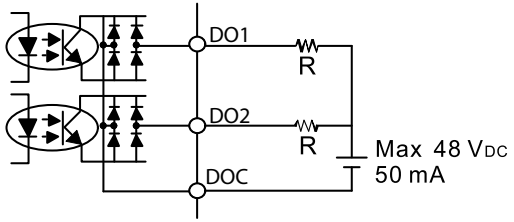
Control Circuit Terminals		
Terminal Symbol	Terminal Function	Description
<b>+24V</b>	Digital control signal common (Source)	+24V ± 10% 100 mA <b>Note:</b> When used in parallel, if the +24V terminal is used with a feedback sensor, unequal current may occur, and there will be a risk of failure.
<b>FWD (DI1) REV (DI2) DI3 - DI7</b>	Digital input 1-7  ① Sink Mode with internal power (+24 V <sub>DC</sub> )   See page 2-35 for sinking/sourcing wiring examples.	<b>Source Mode:</b> ON: activation current 3.3 mA ≥ 11 VDC OFF: cut-off voltage ≤ 5 VDC <b>Sink Mode:</b> ON: activation current 3.3 mA ≤ 13 VDC OFF: cut-off voltage ≥ 19 VDC  DI7: Single pulse input, maximum input frequency=33kHz.  Digital inputs can be configured by the user for many different functions. Refer to P02.01-P02.07 to program the digital inputs FWD (DI1), REV (DI2), DI3-DI7. <ul style="list-style-type: none"> <li>• When P02.00=0, FWD (DI1) and REV (DI2) can be programmed.</li> <li>• When P02.00≠0, the functions of FWD (DI1) and REV (DI2) act according to P02.00 setting.</li> <li>• When P02.07=0, DI7 is pulse input terminal.</li> <li>• DI7 uses pulse input can be used as frequency command source or connect it to the encoder for motor closed-loop control.</li> <li>• DI7 motor closed-loop control only supports VFPG control mode.</li> </ul>
<b>DO</b>	Digital frequency signal output  	DO uses pulse voltage as an output monitoring signal; Duty-cycle: 50 % Min. load impedance RL: 1 kΩ / 100 pF Max. current endurance: 30 mA Max. voltage: 30 VDC ± 1 % (when 30 VDC / 30 mA / RL=100 pF) Max. output frequency: 33 kHz Current-limiting resistor R: ≥ 1 kΩ Output load impedance RL Capacitive load ≤ 100 pF Resistive load ≥ 1 kΩ, resistance determines the output voltage value. DO-DCM voltage = external voltage * ( RL / (RL+R) )
<b>DCM</b>	Digital control / Frequency signal common (Sink)	
<b>DO1</b>	Digital Output 1 (photo coupler)	The AC motor drive outputs various monitoring signals, such as drive in operation, frequency reached, and overload indication through a transistor (open collector). These can be wired as sinking or sourcing (see Appendix D-3).  
<b>DO2</b>	Digital Output 2 (photo coupler)	
<b>DOC</b>	Digital Output Common (photo coupler)	

(continued next page)

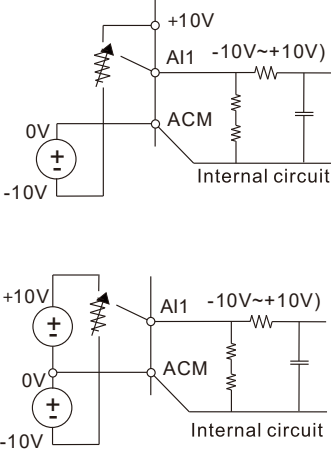
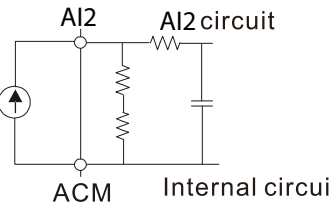
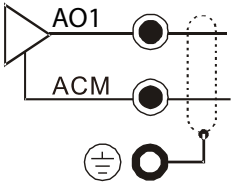
Control Circuit Terminals (continued)		
Terminal Symbol	Terminal Function	Description
<b>R1O</b>	Relay Output 1 (N.O.) a	<b>Resistive Load</b> • 3.0 A (NO), 3.0 A (NC) @ 250VAC • 5.0 A (NO), 3.0 A (NC) @ 30VDC
<b>R1C</b>	Relay Output 1 (N.C.) b	
<b>R1</b>	Relay Output 1 Common	<b>Inductive Load (COS 0.4)</b> • 1.2 A (NO), 1.2 A (NC) @ 250VAC • 2.0 A (NO), 1.2 A (NC) @ 30VDC To output different kinds of monitoring signals such as motor drive in operation, frequency reached, and overload indication.
<b>+10V</b>	Potentiometer power supply	Power supply for analog frequency setting: +10.5 ± 0.5 VDC / 20 mA
<b>AI1</b>	Analog voltage frequency command  	Circuit Impedance: 20kΩ Potentiometer Rating: 5kΩ (for full frequency range) Range: 0–10 V / -10–10 V = 0–Maximum Operation Frequency (P01.00) Mode switching by setting P03.00, P03.28 AI1 resolution=10 bits
<b>AI2</b>	Analog current frequency command  	Impedance: Current mode=250 Ω, Voltage mode=20 kΩ Range: 0–20 mA / 4–20 mA / 0–10 V = 0–Maximum Operation Frequency (P01.00) Mode switching by setting P03.01, P03.29 Switch: The AI2 default is 0–20 mA / 4–20 mA (current mode) AI2 resolution = 12 bits
<b>AO1</b>	Multi-function analog voltage output  	Switch: The AO1 default is 0–10 V (voltage mode). To switch to the current mode, two steps are required: 1) A dip switch must be configured (follow the instructions on the inner side of the front cover or see page 2–33). 2) Change P03.31 to 1 or 2 (see page 4–127). <b>Voltage mode</b> Range: 0–10 V (P03.31=0) corresponds to the maximum operating range of the control target Max. output current: 2 mA Max. Load: 5 kΩ <b>Current mode</b> Range: 0–20 mA (P03.31=1) / 4–20 mA (P03.31=2) corresponds to the maximum operating range of the control target, maximum load 500 Ω AO1 resolution=10 bits
<b>ACM</b>	Analog Signal Common	Analog signal common terminal

(continued next page)

<b>Control Circuit Terminals (continued)</b>		
<b>Terminal Symbol</b>	<b>Terminal Function</b>	<b>Description</b>
<b>STO1, STO2</b>	Default: STO1 / STO2 short-circuited to +24 V Rated voltage: 24 VDC ± 10 %; maximum voltage: 30 VDC ± 10 % Rated current: 6.67 mA ± 10 %	
<b>SCM</b>	<b>STO activation mode</b> Input voltage level: 0 VDC < STO1-SCM or STO2-SCM < 5 VDC STO response time ≤ 20 ms (STO1 / STO2 operates until the AC motor drive stops outputting current) <b>STO cut-off mode</b> Input voltage level: 11 VDC < STO1-SCM and STO2-SCM < 30 VDC Power removal safety function per EN 954-1 and IEC / EN 61508 <b>Note:</b> Refer to Appendix E SAFE TORQUE OFF FUNCTION for details.	
<b>SG+</b>	Modbus RS-485 <b>Note:</b> Refer to Chapter 4, parameter group 09 Communication Parameters for details.	
<b>SG-</b>		
<b>SGND</b>		
<b>RJ45</b>	PIN 1, 2, 6: Reserved PIN 3, 7: SGND PIN 4: SG- PIN 5: SG+ PIN 8: +10V supply GS4-KPD (provides GS4-KPD power)	The RJ45 port provides a serial communications connection. Max Baud Rate = 115.2 kbps
<b>USB</b>	Type B	Port for connecting the drive to GSoft2 and GSLogic for parameter, PLC, and firmware updates.



**GS30 CONTROL TERMINAL BLOCK DIAGRAM & WIRING SPECIFICATIONS**

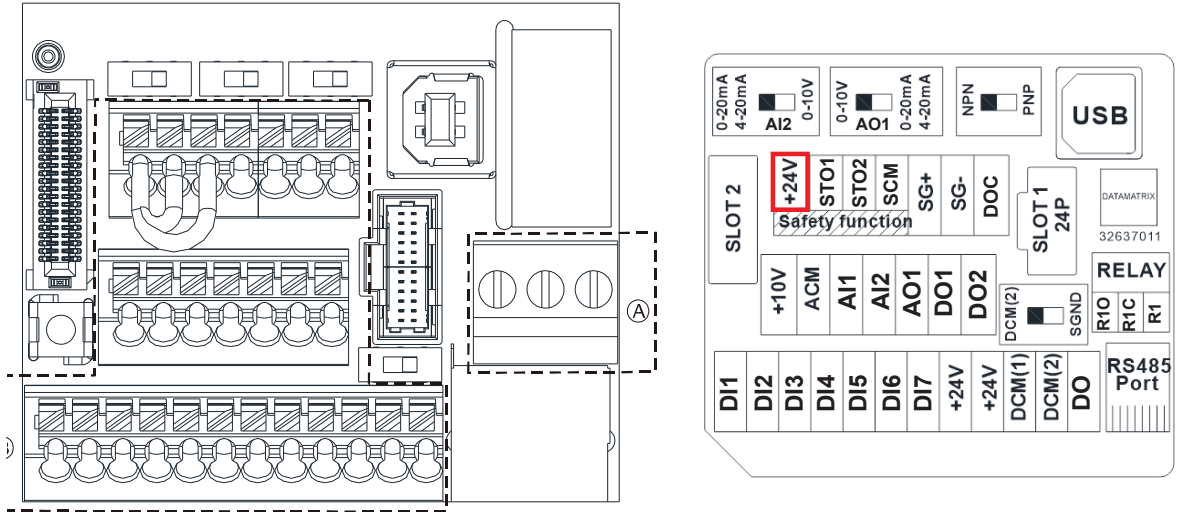

Wiring Specifications					
Terminal	Wiring Type	Stripping Length (mm)	Maximum Wire Gauge	Minimum Wire Gauge	Tightening Torque (kg-cm [lb-in])
Relay	Solid Strand	6-7	1.5 mm <sup>2</sup> (16 AWG)	0.2 mm <sup>2</sup> (24 AWG)	5 kg-cm (4.3 lb-in)
	Solid Strand		0.75 mm <sup>2</sup> (18 AWG)	0.2 mm <sup>2</sup> (24 AWG)	
Control	Stranded with ferrules with plastic sleeves	9	0.5 mm <sup>2</sup> (20 AWG)		

**RECOMMENDED MODELS OR DIMENSIONS FOR FERRULE TERMINALS**

Wire Gauge	Manufacturer	Model Name	A (MAX)	B (MAX)	D (MAX)	W (MAX)
0.25 mm <sup>2</sup> [24 AWG]	PHOENIX CONTACT	AI 0,25- 8 YE	12.5	8	2.6	1.1
0.34 mm <sup>2</sup> [22 AWG]	PHOENIX CONTACT	AI 0,34- 8 TQ	12.5	8	3.3	1.3
0.5 mm <sup>2</sup> [20 AWG]	PHOENIX CONTACT	AI 0,5 - 8 WH	14	8	3.5	1.4
	Z+F	V30AE00006	14	8	2.6	1.15

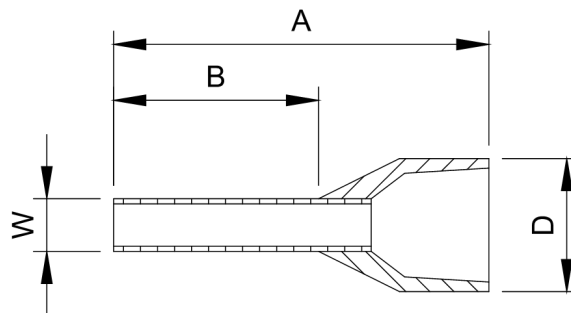

## CONTROL TERMINAL WIRING INSTRUCTIONS

### DIGITAL INPUTS

- When using contacts or switches to control the digital inputs, use high-quality components to avoid contact bounce.

#### Wiring Multiple Drives Together – Digital Inputs

- With drive Digital Inputs in SINKING mode: When connecting a single device to the Digital Inputs of multiple drives (Run, Stop, Reverse, etc.), the DCM (Digital Signal Common) terminals from each drive should be connected together. [DO NOT connect the different drive DCM terminals together if the drive DI are SOURCING.]
- With drive Digital Inputs in SOURCING mode (and the connected field devices are sinking): DO NOT connect the different drive DCM terminals together. [If the DCM terminals of multiple drives are connected together with the drive DI in sourcing mode, the inputs of some of the drives may inadvertently turn ON if another drive is powered OFF.]

**EXAMPLE:** A switch is tied to Digital Input 1 of Drives A, B, C, and D. The Drive inputs are all set to Source current out to the field devices. If Drives A, B and C lose power, their Digital Inputs may sink enough current to inadvertently turn ON Digital Input 1 on Drive D.



**WARNING:** WITH DRIVE DIGITAL INPUTS IN SOURCING MODE  
DO NOT CONNECT THE DIFFERENT DRIVE DCM TERMINALS TOGETHER.

### ANALOG INPUTS

- Analog input signals are easily affected by external noise. Use shielded wiring and keep it as short as possible (<20m) with proper grounding. If the noise is inductive, connect the shield to terminal ACM.
- Use twisted-pair wire
- If the analog input signals are affected by noise from the AC motor drive, please connect a capacitor and ferrite core as indicated in the diagram at right.  
(WIND EACH WIRE AROUND THE CORE 3 TIMES OR MORE.)

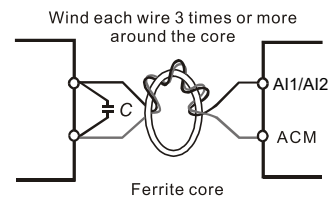

**CONTROL TERMINAL WIRING INSTRUCTIONS (CONTINUED)**

**TRANSISTOR OUTPUTS (DO1, DO2, DOC)**

- Make sure digital outputs are connected with the correct polarity.
- When connecting a relay to digital outputs, connect a surge absorber across the coil of the relay.

**ANALOG OUTPUT**

- When setting dip switch AO1 ensure P03.31 AO1 0~20mA/4~20mA/0~10 V selection is set appropriately.

**PT100**

PT100 RTD circuits should be wired and configured as follows:

- Set P03.00 = 11 (PT100 input)
- If using AI2, set dip switch to 0-10V, set P03.01=11, and P03.29=1.

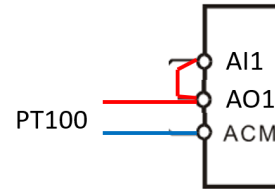

**CONTROL CIRCUIT WIRING DIAGRAMS**

**DIGITAL INPUTS**

① Sink Mode with internal power (+24 V<sub>DC</sub>)

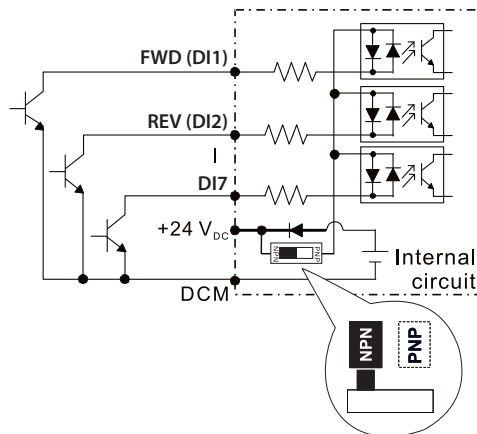

② Source Mode with internal power (+24 V<sub>DC</sub>)

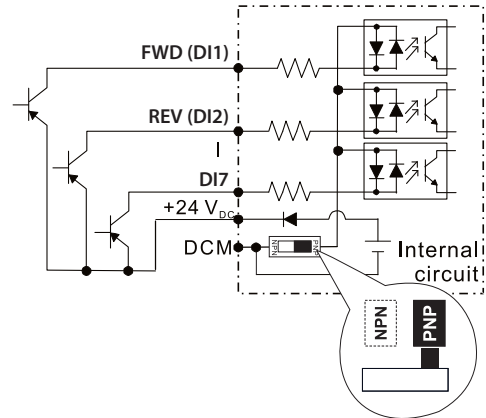

③ Sink Mode with external power

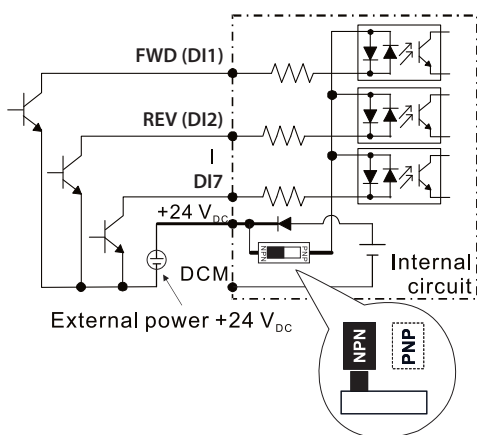

④ Source Mode with external power

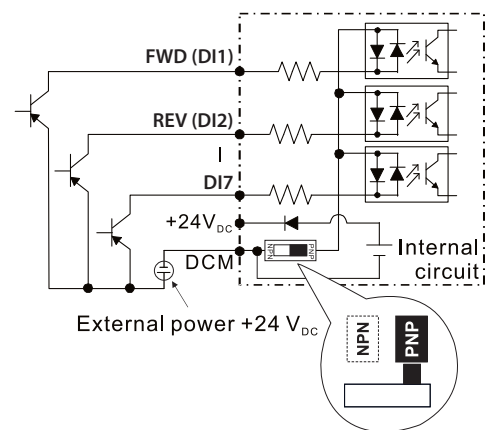

**CONTROL CIRCUIT WIRING DIAGRAMS (CONTINUED)**

**SYSTEM WIRING DIAGRAM**

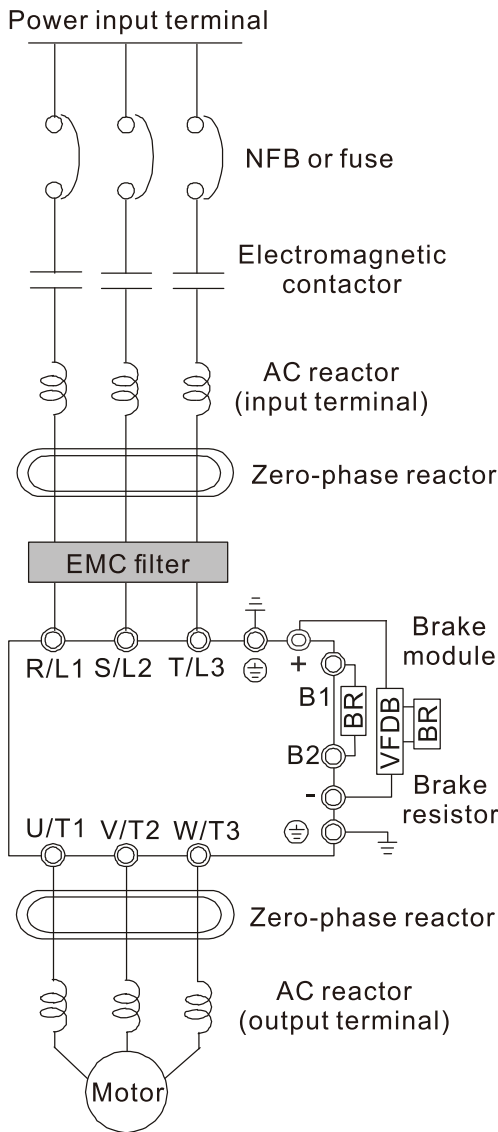

System Wiring Components	
Component	Function
Power input terminal	Supply power according to the rated power specifications indicated in the manual
NFB or fuse	There may be a large inrush current during power on. Select a suitable NFB (Non Fuse Breaker or Circuit Breaker) or Fuse.
Electromagnetic contactor	Switching the power ON/OFF on the primary side of the electromagnetic contactor can turn the drive ON/OFF, but frequent switching can cause machine failure. Do not switch ON/OFF more than once an hour. Do not use the electromagnetic contactor as the power switch for the drive; doing so shortens the life of the drive.
AC reactor (input terminal)	When the main power supply capacity is greater than 500 kVA, or when it switches into a phase capacitor, the instantaneous peak voltage and current generated may destroy the internal circuit of the drive. It is recommended that you install an input side AC reactor in the drive. This also improves the power factor and reduces power harmonics. The wiring distance should be within 10 meters of the drive.
Zero phase reactor	Used to reduce radiated interference, especially in environments with audio devices, and reduce input and output side interference. The effective range is AM band to 10 MHz.
EMC filter	Can be used to reduce electromagnetic interference.
Brake module and Brake resistor (BR)	Used to shorten the deceleration time of the motor.
AC reactor or Filter (output terminal)	The motor cable length affects the size of the reflected wave on the motor end. For motor distances greater than 100 feet, the VTF series dV/dT filter is recommended.

CONTROL CIRCUIT WIRING DIAGRAMS (CONTINUED)

FULL I/O WIRING DIAGRAM (FRAME A-G)

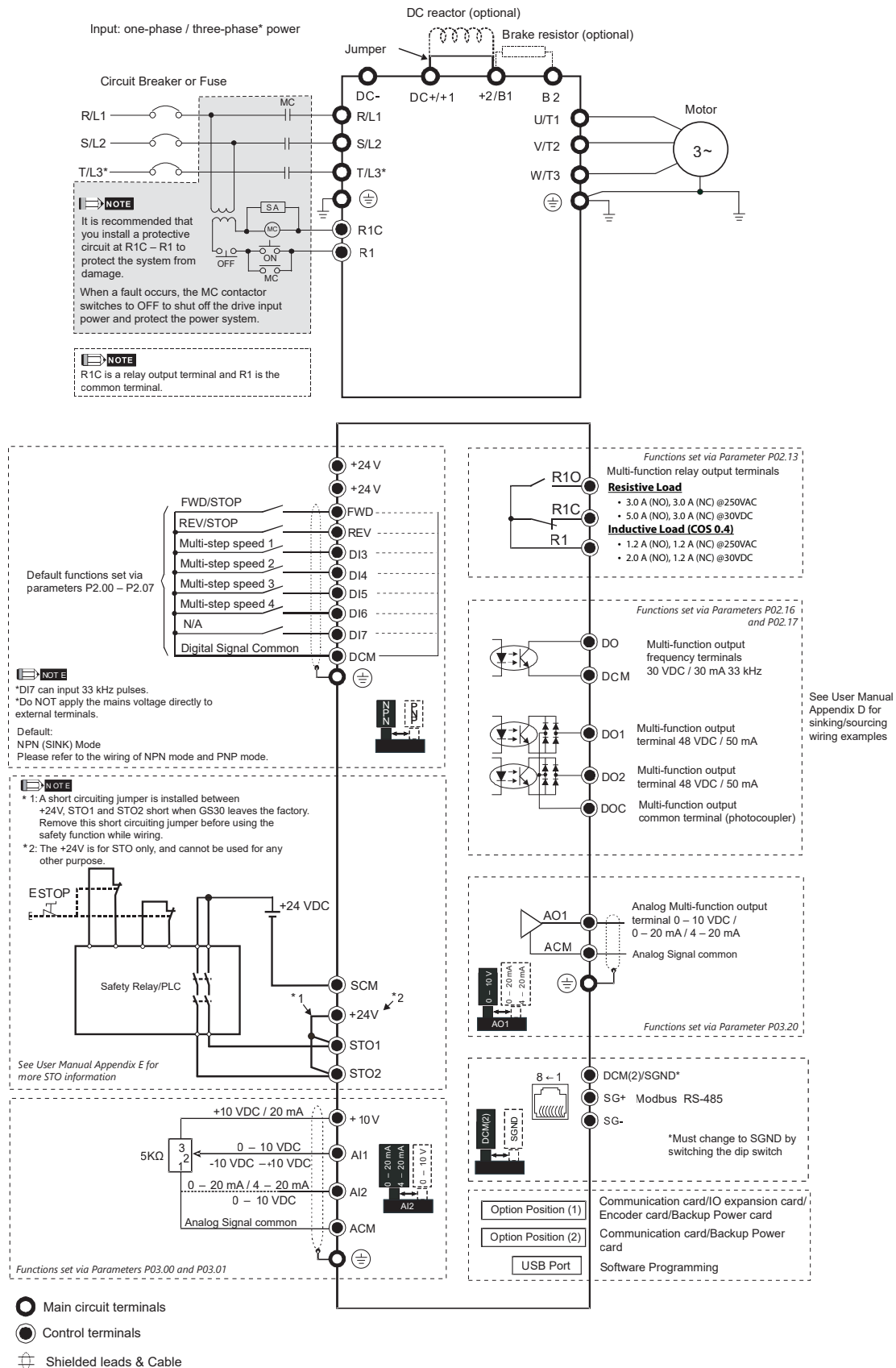

FULL I/O WIRING DIAGRAM (FRAME H-I)

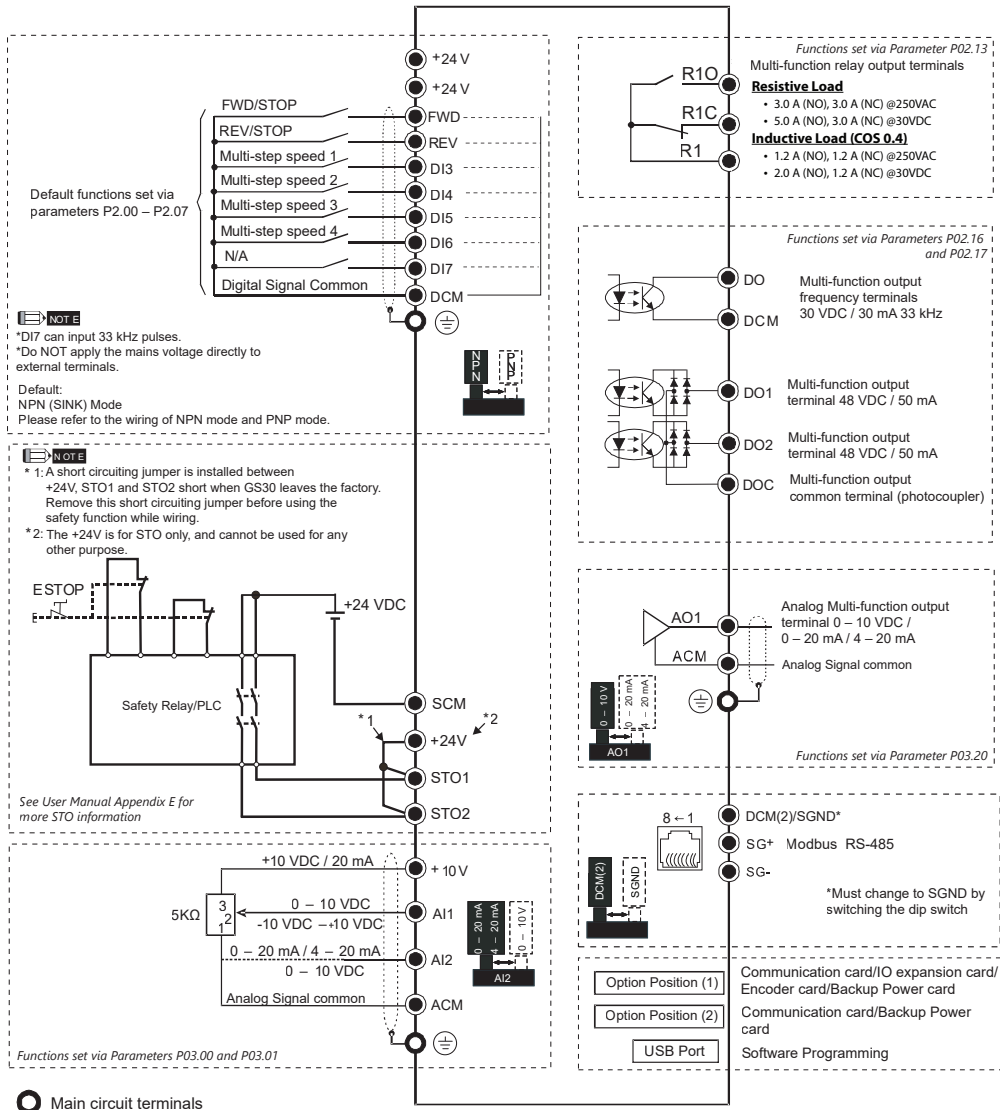
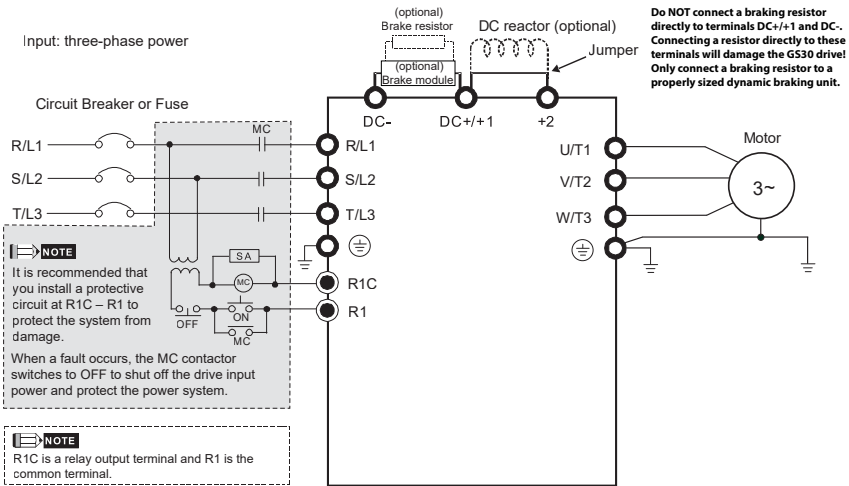

- Main circuit terminals
- Control terminals
- ⊘ Shielded leads & Cable