



5014136304-202405

**GS10 AC DRIVES INSTALLATION INSTRUCTIONS**

**SENSORLESS VECTOR CONTROL VARIABLE FREQUENCY MICRO-DRIVE**

- Please read this instruction sheet thoroughly before installation and retain for later reference.
- To ensure the safety of operators and equipment, only qualified personnel familiar with AC drives should install, wire, program, and operate the GS10 drive. Always read this instruction sheet thoroughly before using the GS10 drive, especially the WARNING, DANGER and CAUTION notes. If you have any questions, please contact AutomationDirect.

**PLEASE READ PRIOR TO INSTALLATION FOR SAFETY**

	<ul style="list-style-type: none"> <li>• The ground terminal of the GS10 drive must be grounded correctly. The grounding method must comply with the laws of the country where the GS10 drive is to be installed.</li> <li>• After power has been turned off, the capacitors in the GS10 drive may retain a charge for several minutes. To prevent personal injury, visually verify that the "CHARGE" LED has turned off. Then measure to confirm that the DC bus voltage level between terminals (+) and (-) is less than 25VDC before touching any terminals. (Capacitor discharge will take at least 5 minutes for most GS10 models).</li> <li>• The CMOS ICs on the internal circuit boards of the GS10 drive are sensitive to static electricity. Please DO NOT touch the circuit boards with your bare hands before taking anti-static measures. Never disassemble the internal components or circuits.</li> <li>• If wiring changes must be made, turn off power to the GS10 drive before making those changes. Allow the internal DC bus capacitors in the GS10 drive sufficient time to discharge prior to making changes in power or control wiring. Failure to do so may result in short circuit and fire. To ensure personal safety, allow DC bus voltage to discharge to a safe level before making wiring changes to the GS10 drive.</li> <li>• DO NOT install the GS10 drive in locations subject to high temperature, direct sunlight, or flammable materials.</li> </ul>
	<ul style="list-style-type: none"> <li>• Never apply power to the output terminals U/T1, V/T2, W/T3 of the GS10 drive. If a fault occurs during operation of the GS10 drive, refer to the fault code descriptions and corrective actions to reset the fault before attempting to operate the GS10 drive.</li> <li>• DO NOT use Hi-pot test for internal components. The semi-conductors in the GS10 drive are easily damaged by high voltage.</li> </ul>
	<ul style="list-style-type: none"> <li>• Long motor lead lengths may result in reflective wave due to impedance mismatch between the motor cable and the motor. Reflective wave may damage the insulation of the motor. To avoid the possibility of reflective wave damage, use an inverter-rated motor with an insulation rating of 1600 volts. A load reactor installed between the GS10 drive and motor will help to mitigate reflective wave.</li> <li>• Nominal supply voltage to the GS10 drive should be less than or equal to 120/240/480 volts AC depending on GS10 model.</li> <li>• Nominal supply current capacity should be less than or equal to 100kA for all GS10 models.</li> <li>• The GS10 drive must be installed in a clean, well-ventilated and dry location, free from corrosive gases or liquids.</li> <li>• The GS10 drive must be stored within an ambient temperature range from -40°C to +85°C, and relative humidity range of 0% to 90% without condensation.</li> <li>• Do not apply AC power to the GS10 drive with the front cover removed. Following a fault of the GS10 drive, wait 5 seconds before pressing the RESET key.</li> <li>• To improve power factor, install a line reactor ahead of the GS10 drive. Do not install power correction capacitors in the main AC supply circuit to the GS10 drive to prevent drive faults due to over-current.</li> </ul>

**MINIMUM WIRING**

- AC input power to R/L1, S/L2, T/L3 (for single-phase input, use two of the terminals) (For applicability of 1-phase input power, please refer to Chapter 1 of the DURApulse GS10 AC Drives User Manual at [AutomationDirect.com](http://AutomationDirect.com).)
- Ground from the power supply
- Drive power to the motor (U, V, W on T1, T2, T3) (For use with 3-phase motors only!)
- Ground to the motor

With this minimal wiring, the drive can be operated via the keypad to test the motor and drive installation. See the "Parameter Set Up" (page 4) section to configure the drive for keypad operation.

**RECOMMENDED SAFETY WIRING**

We strongly recommend that customers configure a multifunction input as the Emergency Stop to stop the drive in an emergency situation. To configure this feature, set any multifunction input to selection 28 (Emergency Stop EF1) and wire a relay or E-stop pushbutton to the configured input.

**WIRING DIAGRAMS**

**RFI JUMPER REMOVAL**



**If the power distribution system supplying the GS10 AC drive is a floating (IT) or an asymmetric ground system (including most 120V inputs), the RFI jumper must be removed.**  
**Removing the RFI jumper uncouples the internal RFI capacitor (filter capacitor) between the GS10 drive frame and circuitry to avoid damaging those circuits and (according to IEC 61800-3) to reduce ground leakage current.**

**GS10 Frame A through D**

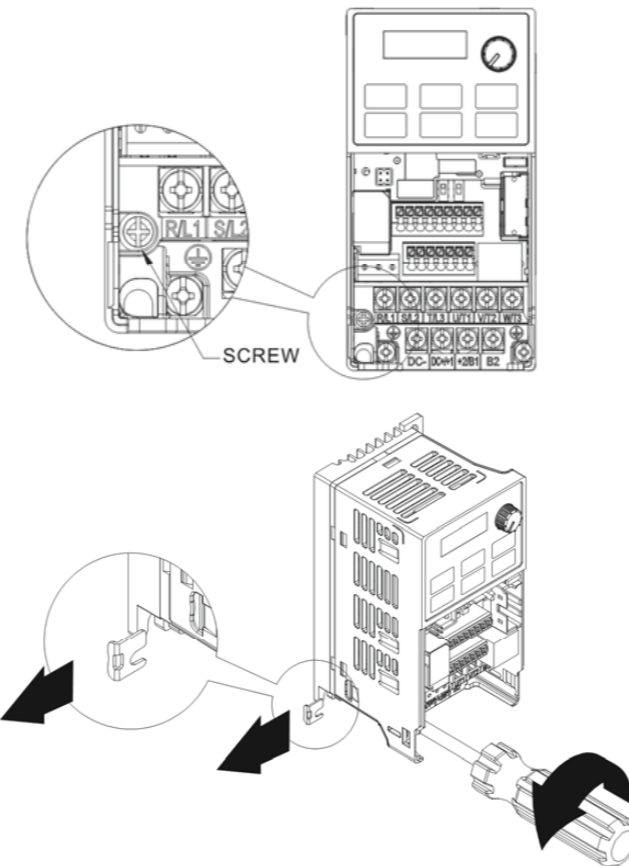

**MAIN WIRING (POWER CIRCUIT)**

For main (power) wiring terminal specifications, Please refer to "Specifications for Wiring Terminals - Main-Circuit Terminals" (page 2).

**GS10 ALL FRAMES**

\*(Note that 1-phase only drives do not have a T/L3 terminal. 120V drives do not have DC- or DC+ terminals).

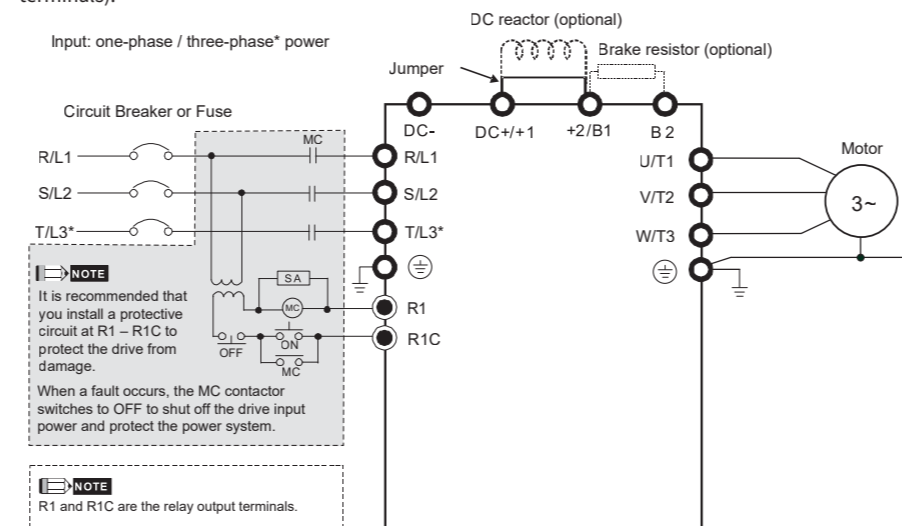

**NOTE**

It is recommended that you install a protective circuit at R1 - R1C to protect the drive from damage.

When a fault occurs, the MC contactor switches to OFF to shut off the drive input power and protect the power system.

**NOTE**

R1 and R1C are the relay output terminals.

**GS10 CONTROL TERMINAL WIRING**

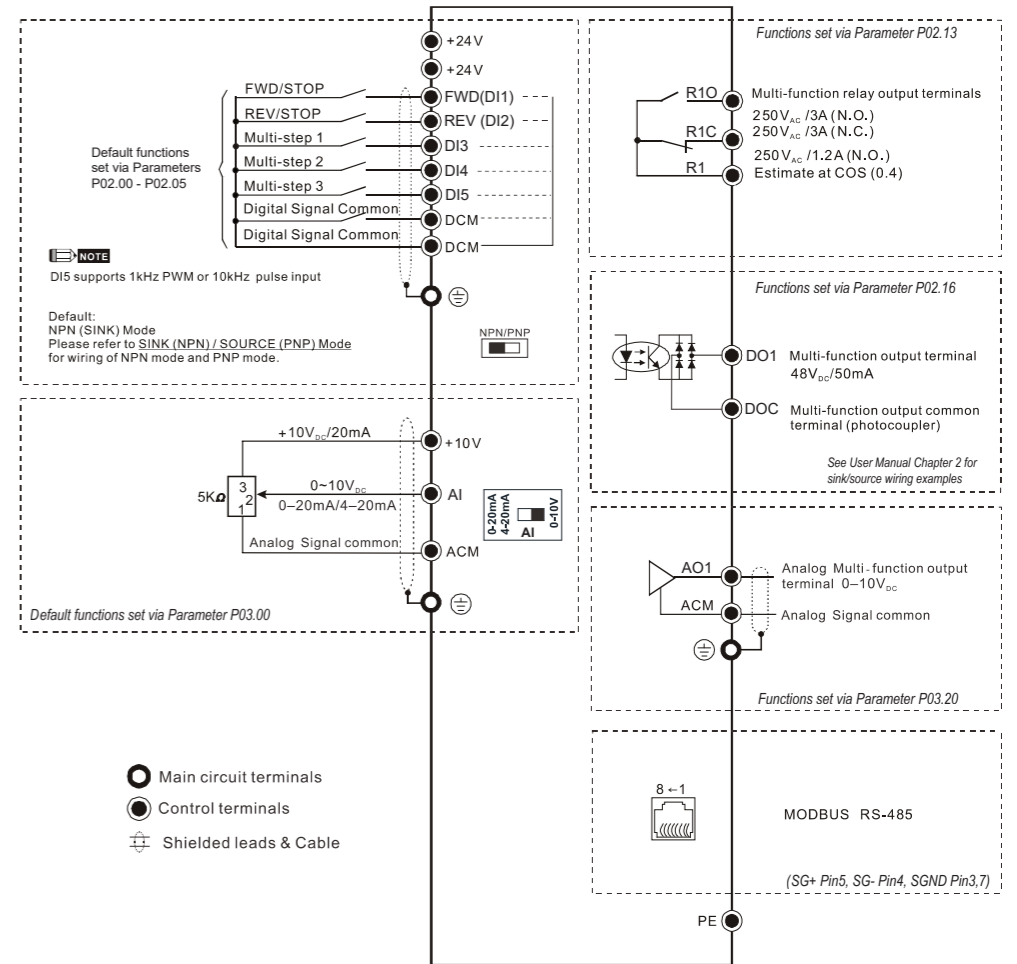

**1 Sink Mode with internal power (+24 V<sub>DC</sub>)**

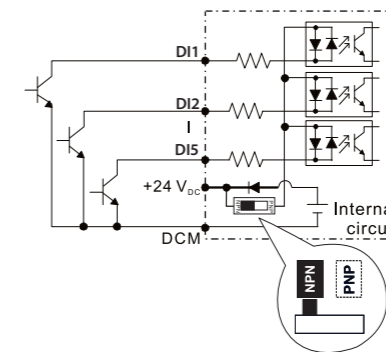

**2 Source Mode with internal power (+24 V<sub>DC</sub>)**

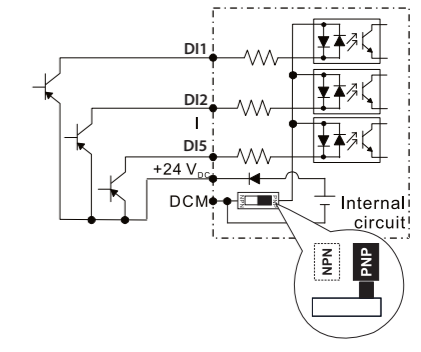

**3 Sink Mode with external power**

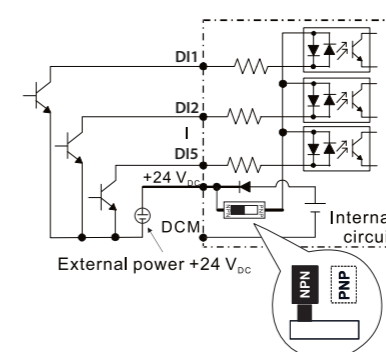

**4 Source Mode with external power**

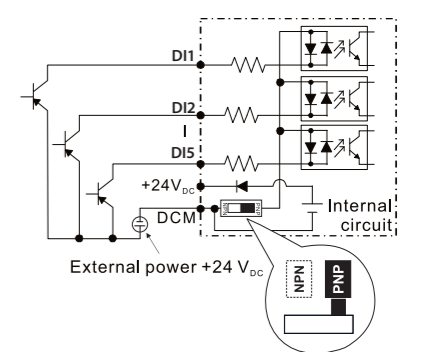

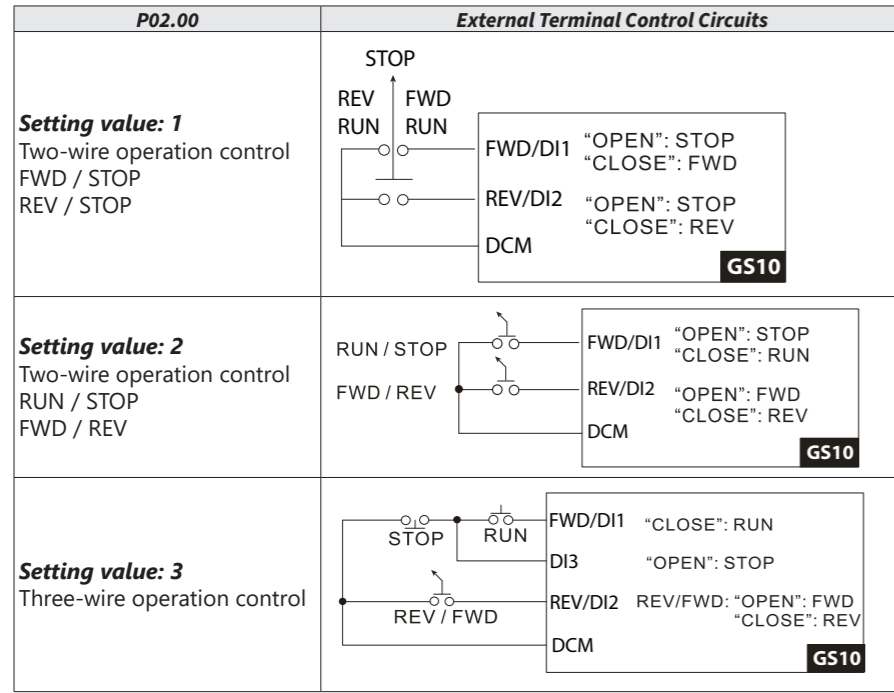

**SPECIFICATIONS FOR WIRING TERMINALS – CONTROL CIRCUIT**

**GS10-xxxx All Models; All Frame Sizes**

Terminal	Wire Gauge	Torque
Control	24-18 AWG [0.21-0.82 mm <sup>2</sup> ]	n/a (spring terminals)
Relay	24-16 AWG [0.21-1.31 mm <sup>2</sup> ]	5kg-cm [4.3 lb-in.]

**WIRING PRECAUTIONS**

- The RELAY terminal uses the PCB terminal block:
  - Tighten the wiring with a 3.5 mm width and 0.6 mm thickness slotted screwdriver.
  - The ideal length of stripped wire at the connection side is 9-10 mm.
  - When wiring bare wires, make sure they are perfectly arranged to go through the wiring holes.
- The control circuit terminal uses a spring clamp terminal block:
  - Tighten the wiring with a 2.5 mm width and 0.4 mm thickness slotted screwdriver.
  - The ideal length of stripped wire at the connection side is 9 mm.

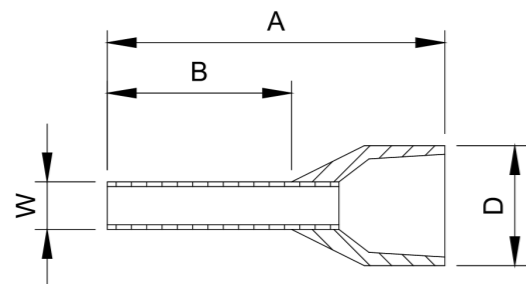

**RECOMMENDED MODELS OR DIMENSIONS FOR FERRULE TERMINALS**

Wire Gauge	Manufacturer	Model Name	A (MAX)	B (MAX)	D (MAX)	W (MAX)
0.25 mm <sup>2</sup> [24 AWG]	PHOENIX CONTACT	AI 0,25- 8 YE	12.5	8	2.6	1.1
0.34 mm <sup>2</sup> [22 AWG]	PHOENIX CONTACT	AI 0,34- 8 TQ	12.5	8	3.3	1.3
0.5 mm <sup>2</sup> [20 AWG]	PHOENIX CONTACT	AI 0,5 - 8 WH	14	8	3.5	1.4

**SPECIFICATIONS FOR WIRING TERMINALS – MAIN-CIRCUIT TERMINALS**

- Notes:**
- If installation environment temperature is greater than 45°C, please use copper wire with a 600V voltage rating and temperature resistance of 90°C or higher.
  - For UL compliant installation, you must:
    - Use 75°C temperature resistant copper wire or better. Do not reduce wire gauge when using higher temperature wire.
    - Use the specific ring lug part listed in the table below.
    - Use crimp tool CRIMPFOX 10S - 1212045 (Phoenix Contact) or DNT13-0101 (Dinkle).

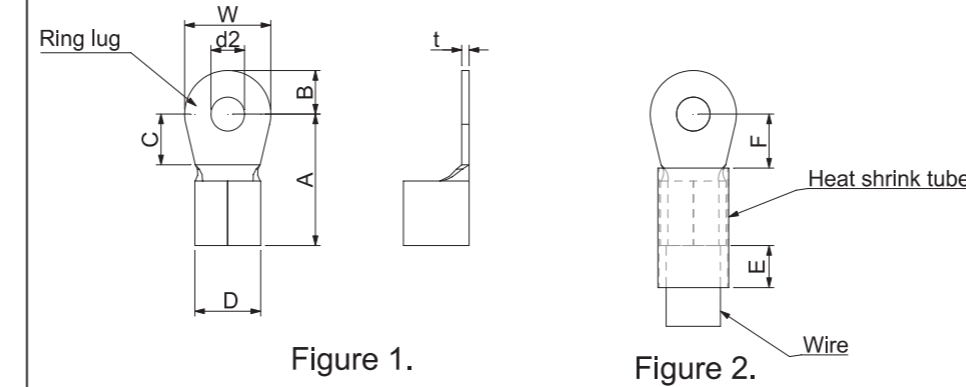

Drive Models	Max Wire Gauge	Min Wire Gauge	Screw	Torque (±10%)	Ring Lug Dimensions (mm)																														
<b>Frame Ax</b>	14AWG [2.5 mm <sup>2</sup> ]	14AWG [2.5 mm <sup>2</sup> ]	M3.5	9 kg-cm [7.8 lb-in.] [0.88 N-m]	<table border="1"> <thead> <tr> <th>Dimension</th> <th>Value</th> <th>Min/Max</th> </tr> </thead> <tbody> <tr><td>A</td><td>9.8</td><td>Max</td></tr> <tr><td>B</td><td>3.2</td><td>Max</td></tr> <tr><td>C</td><td>4.8</td><td>Min</td></tr> <tr><td>D</td><td>4.1</td><td>Max</td></tr> <tr><td>d2</td><td>3.7</td><td>Min</td></tr> <tr><td>E</td><td>13.0</td><td>Min</td></tr> <tr><td>F</td><td>4.2</td><td>Min</td></tr> <tr><td>W</td><td>6.6</td><td>Max</td></tr> <tr><td>t</td><td>0.8</td><td>Max</td></tr> </tbody> </table>	Dimension	Value	Min/Max	A	9.8	Max	B	3.2	Max	C	4.8	Min	D	4.1	Max	d2	3.7	Min	E	13.0	Min	F	4.2	Min	W	6.6	Max	t	0.8	Max
					Dimension	Value	Min/Max																												
					A	9.8	Max																												
					B	3.2	Max																												
					C	4.8	Min																												
					D	4.1	Max																												
					d2	3.7	Min																												
					E	13.0	Min																												
F	4.2	Min																																	
W	6.6	Max																																	
t	0.8	Max																																	
GS11N-10P2																																			
GS11N-10P5																																			
GS11N-20P2																																			
GS11N-20P5																																			
GS13N-20P2																																			
GS13N-20P5																																			
GS13N-21P0																																			
<b>Frame Bx</b>	12AWG [4 mm <sup>2</sup> ]	12AWG [4 mm <sup>2</sup> ]	M4	15 kg-cm [13.0 lb-in.] [1.47 N-m]	<table border="1"> <thead> <tr> <th>Dimension</th> <th>Value</th> <th>Min/Max</th> </tr> </thead> <tbody> <tr><td>A</td><td>12.1</td><td>Max</td></tr> <tr><td>B</td><td>3.6</td><td>Max</td></tr> <tr><td>C</td><td>6.1</td><td>Min</td></tr> <tr><td>D</td><td>5.6</td><td>Max</td></tr> <tr><td>d2</td><td>4.3</td><td>Min</td></tr> <tr><td>E</td><td>13.0</td><td>Min</td></tr> <tr><td>F</td><td>4.5</td><td>Min</td></tr> <tr><td>W</td><td>7.2</td><td>Max</td></tr> <tr><td>t</td><td>1</td><td>Max</td></tr> </tbody> </table>	Dimension	Value	Min/Max	A	12.1	Max	B	3.6	Max	C	6.1	Min	D	5.6	Max	d2	4.3	Min	E	13.0	Min	F	4.5	Min	W	7.2	Max	t	1	Max
					Dimension	Value	Min/Max																												
					A	12.1	Max																												
B	3.6	Max																																	
C	6.1	Min																																	
D	5.6	Max																																	
d2	4.3	Min																																	
E	13.0	Min																																	
F	4.5	Min																																	
W	7.2	Max																																	
t	1	Max																																	
GS11N-21P0																																			
GS13N-22P0																																			
GS13N-42P0	14AWG [2.5 mm <sup>2</sup> ]	14AWG [2.5 mm <sup>2</sup> ]			<table border="1"> <thead> <tr> <th>Dimension</th> <th>Value</th> <th>Min/Max</th> </tr> </thead> <tbody> <tr><td>A</td><td>9.8</td><td>Max</td></tr> <tr><td>B</td><td>3.2</td><td>Max</td></tr> <tr><td>C</td><td>4.8</td><td>Min</td></tr> <tr><td>D</td><td>4.1</td><td>Max</td></tr> <tr><td>d2</td><td>3.7</td><td>Min</td></tr> <tr><td>E</td><td>13.0</td><td>Min</td></tr> <tr><td>F</td><td>4.2</td><td>Min</td></tr> <tr><td>W</td><td>6.6</td><td>Max</td></tr> <tr><td>t</td><td>0.8</td><td>Max</td></tr> </tbody> </table>	Dimension	Value	Min/Max	A	9.8	Max	B	3.2	Max	C	4.8	Min	D	4.1	Max	d2	3.7	Min	E	13.0	Min	F	4.2	Min	W	6.6	Max	t	0.8	Max
Dimension	Value	Min/Max																																	
A	9.8	Max																																	
B	3.2	Max																																	
C	4.8	Min																																	
D	4.1	Max																																	
d2	3.7	Min																																	
E	13.0	Min																																	
F	4.2	Min																																	
W	6.6	Max																																	
t	0.8	Max																																	

**SPECIFICATIONS FOR WIRING TERMINALS – MAIN-CIRCUIT TERMINALS (CONTINUED)**

Drive Models	Max Wire Gauge	Min Wire Gauge	Screw	Torque (±10%)	Ring Lug Dimensions (mm)																														
<b>Frame C</b>	8AWG [10 mm <sup>2</sup> ]	8AWG [10 mm <sup>2</sup> ]	M4	20 kg-cm [17.4 lb-in.] [1.96 N-m]	<table border="1"> <thead> <tr> <th>Dimension</th> <th>Value</th> <th>Min/Max</th> </tr> </thead> <tbody> <tr><td>A</td><td>17.8</td><td>Max</td></tr> <tr><td>B</td><td>5.0</td><td>Max</td></tr> <tr><td>C</td><td>6.1</td><td>Min</td></tr> <tr><td>D</td><td>7.2</td><td>Max</td></tr> <tr><td>d2</td><td>4.3</td><td>Min</td></tr> <tr><td>E</td><td>13.0</td><td>Min</td></tr> <tr><td>F</td><td>5.5</td><td>Min</td></tr> <tr><td>W</td><td>10.5</td><td>Max</td></tr> <tr><td>t</td><td>1.2</td><td>Max</td></tr> </tbody> </table>	Dimension	Value	Min/Max	A	17.8	Max	B	5.0	Max	C	6.1	Min	D	7.2	Max	d2	4.3	Min	E	13.0	Min	F	5.5	Min	W	10.5	Max	t	1.2	Max
					Dimension	Value	Min/Max																												
					A	17.8	Max																												
					B	5.0	Max																												
					C	6.1	Min																												
					D	7.2	Max																												
d2	4.3	Min																																	
E	13.0	Min																																	
F	5.5	Min																																	
W	10.5	Max																																	
t	1.2	Max																																	
GS11N-11P0																																			
GS11N-22P0																																			
GS11N-23P0																																			
GS13N-23P0																																			
GS13N-25P0																																			
<b>Frame D</b>	8AWG [10 mm <sup>2</sup> ]	8AWG [10 mm <sup>2</sup> ]	M4	20 kg-cm [17.4 lb-in.] [1.96 N-m]	<table border="1"> <thead> <tr> <th>Dimension</th> <th>Value</th> <th>Min/Max</th> </tr> </thead> <tbody> <tr><td>A</td><td>17.8</td><td>Max</td></tr> <tr><td>B</td><td>5.0</td><td>Max</td></tr> <tr><td>C</td><td>6.1</td><td>Min</td></tr> <tr><td>D</td><td>7.2</td><td>Max</td></tr> <tr><td>d2</td><td>4.3</td><td>Min</td></tr> <tr><td>E</td><td>13.0</td><td>Min</td></tr> <tr><td>F</td><td>5.5</td><td>Min</td></tr> <tr><td>W</td><td>10.5</td><td>Max</td></tr> <tr><td>t</td><td>1.2</td><td>Max</td></tr> </tbody> </table>	Dimension	Value	Min/Max	A	17.8	Max	B	5.0	Max	C	6.1	Min	D	7.2	Max	d2	4.3	Min	E	13.0	Min	F	5.5	Min	W	10.5	Max	t	1.2	Max
					Dimension	Value	Min/Max																												
					A	17.8	Max																												
					B	5.0	Max																												
C	6.1	Min																																	
D	7.2	Max																																	
d2	4.3	Min																																	
E	13.0	Min																																	
F	5.5	Min																																	
W	10.5	Max																																	
t	1.2	Max																																	
GS13N-27P5																																			
GS13N-47P5																																			
GS13N-40I0																																			

**DIGITAL KEYPAD FUNCTIONS AND INDICATIONS**

Description of the functions of the keys and indicators of the GS10 AC Drive Keypad.

**NOTE:** Drive default is AUTO mode. There is no indication from the keypad of the mode. Local mode can be set with I/O configuration or GS4-KPD only.



Descriptions of Keypad Functions	
	<p><b>RUN Key</b></p> <ul style="list-style-type: none"> <li>Valid only when the source of operation command is from the keypad.</li> <li>RUN can be pressed even when drive is in process of stopping.</li> <li>When in "LOCAL" mode, RUN is valid only when the source of operation command is from the keypad (drive default is Auto mode, Local mode can be set with I/O or GS4-KPD only).</li> </ul>
	<p><b>STOP/RESET Key</b></p> <p>This key has the highest processing priority in any situation.</p> <ul style="list-style-type: none"> <li>When the drive receives a STOP command, whether or not the drive is in operation or stop status, the drive will execute a "STOP" command.</li> <li>The RESET key can be used to reset the drive after a fault occurs. For those faults that can't be reset by the RESET key, see the fault records after pressing MENU key for details.</li> </ul> <p><i>NOTE: The ability to STOP the drive from the keypad is effective ONLY if the drive is configured to RUN and/or STOP from the keypad. Keypad STOP can be disabled by parameter 00.32, Digital Keypad STOP Function.</i></p>
	<p><b>ENTER Key</b></p> <p>Press ENTER to go to the next menu level or accept parameter entry. If it is the last level, then press ENTER to execute the command.</p>
	<p><b>MENU Key</b></p> <p>Press MENU to return to the Main Menu or cycle through the available menu options.</p>
	<p><b>Direction: Up</b></p> <p>Press to make the value set on the current menu/parameter higher.</p>
	<p><b>Direction: Left/Down</b></p> <ul style="list-style-type: none"> <li>Press to make the value set on the current menu/parameter lower.</li> <li>In the menu/text selection mode, the arrows are used for item selection. Long press the MENU key to use the left direction function.</li> </ul>
	<p><b>Frequency Setting Dial (Potentiometer)</b></p> <p>The dial can be set as the main frequency input. Set Parameter 00-20 or 00-30 to '7-Digital Keypad Dial'.</p>

Descriptions of LED Functions	
<b>RUN</b>	<p><b>Steady ON:</b> Drive is running.</p> <p><b>Blinking:</b> Drive is stopping or in base block.</p> <p><b>Steady OFF:</b> Drive is not running.</p>
<b>FWD</b>	<p><b>Steady ON:</b> Drive is operating in Forward mode.</p> <p><b>Blinking:</b> Drive is changing direction.</p> <p><b>Steady OFF:</b> Drive is operating in Reverse mode.</p>
<b>REV</b>	<p><b>Steady ON:</b> Drive is operating in Reverse mode.</p> <p><b>Blinking:</b> Drive is changing direction.</p> <p><b>Steady OFF:</b> Drive is operating in Forward mode.</p>
<b>STOP</b>	<p><b>Steady ON:</b> Drive is stopped or in the process of stopping.</p> <p><b>Blinking:</b> Drive is in standby (run but does not output).</p> <p><b>Steady OFF:</b> Drive is not currently executing an operational (STOP) command.</p> <p><i>NOTE: The ability to STOP the drive from the keypad is effective ONLY if the drive is configured to RUN and/or STOP from the keypad. Keypad STOP can be disabled by parameter 00.32, Digital Keypad STOP Function.</i></p>

**KEYPAD NAVIGATION EXAMPLE**

Instruction	Press Key	Display Will Show
First menu to display after power up.	n/a	Displays the present frequency setting of the drive RUN ● FWD ● REV ● <b>F600</b> ● STOP
Press MENU once from startup.	MENU	Displays the actual output frequency of the drive RUN ● FWD ● REV ● <b>H500</b> ● STOP
Press MENU twice from startup.	MENU	Displays user defined output RUN ● FWD ● REV ● <b>U 18</b> ● STOP
Press MENU three times from startup.	MENU	Displays output current RUN ● FWD ● REV ● <b>A 50</b> ● STOP
Press MENU four times from startup. Displays Frd if the drive is currently configured for Forward operation. Press the UP or DOWN key to change to Reverse. Press ENTER to confirm the change.	MENU, UP/DOWN, ENTER	Displays the Forward command if configured for Forward operation RUN ● FWD ● REV ● <b>Frd</b> ● STOP
		Displays the Reverse command if configured for Reverse operation RUN ● FWD ● REV ● <b>rEv</b> ● STOP
Enable the counter by setting parameter 00.04 to 1. See the user manual for full instructions on using the counter.	MENU	Displays the counter value RUN ● FWD ● REV ● <b>c 20</b> ● STOP
After selecting the desired menu option, press ENTER to bring up the parameter number (Format XX.YY). Use the UP and DOWN arrow keys to change the parameter number as needed, then press ENTER to adjust the parameter value.	ENTER, UP/DOWN, ENTER	Displays the parameter number RUN ● FWD ● REV ● <b>0600</b> ● STOP
From the parameter number screen, press ENTER to bring up the current value of the selected parameter. Use the UP and DOWN arrows to adjust the value. Press ENTER again to confirm the choice.	ENTER, UP/DOWN	Displays the value of the selected parameter RUN ● FWD ● REV ● <b>10</b> ● STOP
Once a desired parameter value has been set using the UP and DOWN arrow keys, press ENTER to save the choice and display End message.	ENTER	End message. Displays when data has been accepted and stored RUN ● FWD ● REV ● <b>End</b> ● STOP
Displays when an external fault is detected.	n/a	External fault message RUN ● FWD ● REV ● <b>EF</b> ● STOP
Displays when data is not accepted or the value exceeded.	n/a	Error message RUN ● FWD ● REV ● <b>Err</b> ● STOP

After changing all of the applicable parameters, press MENU key to return to the Menu screen, and then press ESC key to return to the home screen.

**GS10 FAULT CODES**

See Chapter 6 of the User Manual for more details.

Fault Codes					
Number	Code	Description	Number	Code	Description
0	n/a	No Error	37	Hd1	Over-current detection error
1	ocA	Overcurrent during Accel	40	AuE	Auto tuning error
2	ocd	Overcurrent during Decel	41	AFE	PID Feedback loss
3	ocn	Overcurrent during constant speed	48	ACE	Analog current input loss
4	GFF	Ground Fault	49	EF	External Fault input
6	ocS	Overcurrent during Stop	50	EF1	Emergency Stop
7	ovA	Overvoltage during Accel	51	bb	External Base Block
8	ovd	Overvoltage during Decel	52	Pcod	Password Error
9	ovn	Overvoltage during constant speed	54	CE1	Communication Error
10	ovS	Overvoltage during Stop	55	CE2	Communication Error
11	LvA	Low voltage during Accel	56	CE3	Communication Error
12	Lvd	Low voltage during Decel	57	CE4	Communication Error
13	Lvn	Low voltage during constant speed	58	CE10	PC Communication Time Out
14	LvS	Low voltage during Stop	61	ydc	Y-Delta connection Error
15	OrP	Input phase loss	62	dEb	Decel Energy Backup Error
16	oH1	IGBT Overheat 1	63	oSL	Slip Error
18	tH1o	Thermister 1 open	79	Aoc	U Phase over current before run
21	oL	Drive overload	80	boc	V Phase over current before run
22	EoL1	Electronics thermal relay protection 1	81	coc	W Phase over current before run
23	EoL2	Electronics thermal relay protection 2	72	oPL1	U Phase output phase loss
24	oH3	Motor Overheat-PTC	73	oPL2	V Phase output phase loss
26	ot1	Over Torque 1	84	oPL3	W Phase output phase loss
27	ot2	Over Torque 2	87	oL3	Drive over load in low frequency
28	uc	Under current	89	roPd	Initial rotor position detection error
31	cF2	Memory read-out error	140	Hd6	GFF detected when power on
33	cd1	U phase current sensor detection error	141	b4GFF	GFF occurs before run
34	cd2	V phase current sensor detection error	142	AUE1	Auto tuning error 1 (DC test stage)
35	cd3	W phase current sensor detection error	143	AUE2	Auto tuning error 2 (High frequency test stage)
36	Hd0	Clamp current detection error	144	AUE3	Auto tuning error 3 (Rotary test stage)

**INTRODUCTION – HOW TO GET STARTED**

Automationdirect.com would like to thank you for your purchase of the Durapulse GS10 AC drive. The GS10 drive is a state-of-the-art, full-featured AC drive. The Quick-Start Guide below will introduce you to many of the GS10 drive features and help you configure the GS10 drive in a minimum amount of time.

**Emergency Stop**

The GS10 drive offers a standard Emergency Stop circuit.

Please see the Control-Circuit Wiring diagrams and Safety wiring (page 1) for how to wire the multifunction input as the Emergency Stop.

After wiring the drive (but before applying power), test the system by pressing the E-stop button (or otherwise break the safety circuit) and verify that the E-stop digital input is triggered. When the E-stop is active, EF1 will display on the drive LED and the drive will not run.

**Powering Up the GS10 Drive**

Apply AC line power to the GS10 drive, but don't engage the safety circuit yet (keep the E-stop PB pushed in).

**Starting, Stopping, and Controlling the Speed of the GS10 Drive**

Out of the box GS10 drives are set to use the keypad buttons to RUN and STOP the drive and vary the drive speed. The drive can also be configured to run from potentiometers, external pushbuttons, etc.

Do not attempt to run the motor yet. Certain parameters (especially the motor protection parameters) must be set first.

**Configure the Drive**

The tables below list those parameters typically used in most applications. You can navigate to any of these parameters through the keypad. (Refer to page 3 for information and instructions for using the Digital Keypad.) Before configuring the drive, reset the drive to defaults. Set P00.02=9 (50Hz) or 10 (60Hz). Then cycle power to the drive.

All applications need to configure the parameters in the "Quick Configuration" table. At minimum, you MUST configure these motor parameters before operating the drive:

- 01.02 Motor1 Max Output Voltage (this will typically be either 230V or 460V)
- 05.01 Motor1 Rated Amps (depends on the motor)
- 01.01 Motor1 Max Output Frequency (this will typically be 50Hz or 60Hz)

The main configuration parameters required to get your drive up and running are included in this guide. For more advanced configuration options, please see the User Manual. Your application will dictate which parameters need to be configured. It is NOT necessary to configure every parameter listed in the tables in the User Manual, use only those you need.

**Parameter Groups**

Group Number	Group Category
00	Drive Config
01	Basic Config
02	Digital I/O Config
03	Analog I/O Config
04	Multi-Step Speed Config
05	Motor Config
06	Protection Config
07	Special Parameters
08	PID Config
09	Communications Config
10	Speed Control Config
11	Advanced Config
12	Function
13	Macro Config
14	Protection (2) Config

After configuring the minimum settings, you can now engage the safety circuit. The RUN and STOP/RESET buttons should Start and Stop the drive. To adjust the output frequency, press the MENU button until the frequency screen appears. Use the Up and Down arrow buttons to adjust the frequency, the press ENTER to confirm. Press ENTER again to return to the main menu.

**PARAMETER SET UP**

DURAPULSE GS10 AC Drives offer parameter setup from the keypad for some of the most common drive applications. Choose parameters from the table below, then set the applicable parameters for that application as shown.

**To Configure Parameters:**

From the power up screen:

- 1) Press **MENU** until you see **H 0.00** (this is the actual drive frequency) and press **ENTER**.
- 2) Use the **UP/DWN** arrows to select the parameter group you want and press **ENTER**.
- 3) Use the **UP/DWN** arrows to select the parameter number you want within that group and press **ENTER**.
- 4) Change the value of the parameter using the **UP/DWN** arrows and press **ENTER**.
- 5) Press **MENU** to exit back to the main menu.
- 6) Repeat as needed until all required parameters are configured.



**Please refer to the user manual if you need more detailed information about the parameters.**

DURAPULSE GS10 Parameter Settings – Quick Configuration*					
Parameter Group	#	Description	Range	Default	User
00	00	GS10 Model ID	Read Only	n/a	
00	01	Displays AC drive rated current	Displays value based on model	n/a	
00	02	Restore to default**	0=No function 1=Parameter write protect 5=Reset kWh display to 0 8=Keypad disable 9=Reset 50Hz defaults 10=Reset 60Hz defaults 11=Reset 50Hz defaults (keep user config) 12=Reset 60Hz defaults (keep user config)	0	
00	06	Firmware Version	Read Only	n/a	
00	11	Speed Control Mode	0=VF (IM V/F control) 2=SVC (Parameter 05.33 set as IM or PM)	0	
00	16	Load Selection	0=VT (Variable Torque) 1=CT (Constant Torque)	1	
00	20	Frequency Command Source (Auto)	0=Digital keypad 1=Communication RS-485 input 2=External analog input (refer to parm 03.00) 3=External UP/DOWN terminal 4=Pulse input without direction command (refer to parm 10.16 without direction) 7=Digital keypad dial	0	
00	21	Operation Command Source (Auto)	0=Digital keypad 1=External terminals 2=Communication RS-485 input	0	
00	22	Stop Method	0=Ramp to stop 1=Coast to stop 2=Stop by simple positioning	0	
00	23	Motor Direction Control	0=Enable forward/reverse 1=Disable reverse 2=Disable forward	0	
01	00	Motor 1 Max Frequency	0.00-599.0 Hz	60	
01	01	Motor 1 Base Frequency	0.00-599.0 Hz	60	
01	02	Motor 1 Rated Voltage	110V/230V: 0.0~255.0 460V: 0.0~510.0V	220.0 440.0	
01	09	Startup Frequency	0.00-599.0 Hz	0.5	
01	10	Output Frequency Upper Limit	0.00-599.0 Hz	599.0	
01	11	Output Frequency Lower Limit	0.00-599.0 Hz	0.00	
01	12	Acceleration Time 1	P01.45=0: 0.00-600.0 sec P01.45=1: 0.00-6000 sec	10.00 10.00	
01	13	Deceleration Time 1	P01.45=0: 0.00-600.0 sec P01.45=1: 0.00-6000 sec	10.00 10.00	
01	20	Jog Acceleration Time	P01.45=0: 0.00-600.0 sec P01.45=1: 0.00-6000 sec	10.00 10.00	
01	21	Jog Deceleration Time	P01.45=0: 0.00-600.0 sec P01.45=1: 0.00-6000 sec	10.00 10.00	
01	22	Jog Frequency	0.00-599.0 Hz	6.00	

\* Assumes default V/Hz mode with no feedback. To change control modes see complete parameter listing in User manual.  
\*\* Reboot drive after resetting defaults.  
Note: Drive default is Auto mode and cannot be changed from the keypad. For Local/Hand, use Discrete input configuration settings (P02.00–P02.05) and P00.29–P00.31.

(table continued next column)

DURAPULSE GS10 Parameter Settings – Quick Configuration (continued)					
Parameter	Description	Range	Default	User	
02	00	2-wire / 3-wire Control	0=No function 1=2-wire mode 1, power on for operation control (M1: FWD/STOP, M2: REV/STOP) 2=2-wire mode 2, power on for operation control (M1: RUN/STOP, M2: REV/FWD) 3=3-wire, power on for operation control (M1: RUN, M2: REV/FWD, M3: STOP) 4=2-wire mode 1, fast start up (M1: FWD/STOP, M2: REV/STOP) 5=2-wire mode 2, fast start up (M1: RUN/STOP, M2: REV/FWD) 6=3-wire, fast start up (M1: RUN, M2: REV/FWD, M3: STOP) Note: In fast start up mode, the drive skips detecting start signal and will run immediately. When using fast start up mode: • Terminal output stays in ready status and drive responds to commands immediately. • The output terminal will have higher voltage • If the drive is short circuited an OC error will display when running up	1	
02	01	Multi-function Input Command 1 (FWD/DI1)		0	
02	02	Multi-function Input Command 2 (REV/DI2)		0	
02	03	Multi-function Input Command 3 (DI3)		1	
02	04	Multi-function Input Command 4 (DI4)		2	
02	05	Multi-function Input Command 5 (DI5)		3	
02	13	Multi-function Output 1 (R1)		11	
02	16	Multi-function Output 2 (DO1)		0	
02	35	Auto-run on Power up (includes after a Fault reset)	0: Disable 1: Drive Runs if Cmd ON after Flt Reset or Pwr up	0	
03	00	Analog Input Selection (AI)		1	
03	20	Multi-function Output (AO1)		0	
03	28	AI terminal input selection	0=0-10 V 1=0-20 mA 2=4-20 mA	0	
04	to 14	Multi-step Speed Frequency 1–15	0.00-599.0 Hz	0.00	
05	00	Motor Parameter Auto-tuning (use with P00.11=2)	0=No function 1=Dynamic test for induction motor (IM) 2=Static test for induction motor (IM) 5=PM Rotary tuning 13=PM Static tuning	0	
05	01	Motor 1 Full Load Amps (FLA)	10-120% of drive rated current	###	
05	03	Motor 1 Rated RPM	0-65535	1710	
05	04	Motor 1 Number of poles	2-20	4	
06	06	Over-torque Detection Selection (Motor 1)	0=No function 1=Continue operation after over-torque detection during constant speed operation 2=Stop after over-torque detection during constant speed operation 3=Continue operation after over-torque detection during RUN 4=Stop after over-torque detection during RUN	0	
06	07	Over-torque Detection Level (Motor 1)	10-250% (100% corresponds to the rated current of the drive)	120	
06	08	Over-torque Detection Time (Motor 1)	0.1-60.0 seconds	0.1	
06	13	Motor 1 Electronic Thermal Overload Relay	0=Inverter motor (with external forced cooling) 1=Standard motor (motor with fan on the shaft) 2=Disabled Note: A value of 0 or 1 is recommended to protect the motor in most applications.	1	
06	14	Motor 1 Electronic Thermal Relay Time	30.0-600.0	60	
06	55	Drive Derating Method	0=Constant rated current and limit carrier wave by load current and temperature 1=Constant carrier frequency and limit load current by setting carrier wave 2=Constant rated current (same as setting 0) but close current limit	0	
07	10	Restart after fault action	0=Stop operation 1=Speed tracking by current speed 2=Speed tracking by minimum output frequency	0	

(table continued next page)

DURAPULSE GS10 Parameter Settings – Quick Configuration (continued)					
Parameter Group	#	Description	Range	Default	User
07	11	Number of times of restart after fault	0-10	0	
07	19	Fan cooling control	0=Fan is always ON 1=Fan is OFF after the AC motor drive stops for one minute 2=Fan is ON when the AC motor drive runs, fan is OFF when the AC motor drive stops 3=Fan turns ON when temperature (IGBT) reaches approximately 60°C 5=Fan turns ON/OFF when the AC motor drive runs/stops and stays in Stand by mode at zero speed.	3	
08	00	Terminal selection of PID feedback	0=No function 1=Negative PID feedback: by analog input (P03.00) 4=Positive PID feedback: by analog input (P03.00) 7=Negative PID feedback: by communication protocols 8=Positive PID feedback: by communication protocols	0	
08	01	Proportional gain (P)	0.0-1000 (When P08.23 bit 1=0) 0.00-100.0 (When P08.23 bit 1=1)	1.00	
08	02	Integral time (I)	0.00-100.0 sec.	1.00	
08	03	Differential time (D)	0.00-1.00 sec.	0.00	
08	04	Upper limit of integral control	0.0-100.0%	100.0	
08	05	PID output command limit (positive limit)	0.0-100.0%	100.0	
08	06	PID feedback value by communication protocol	-200.0-200.0%	0.00	
08	07	PID delay time	0.0-2.5 sec.	0.0	
08	08	Feedback signal detection time	0.0-3600 sec.	0.0	
08	09	Feedback signal fault treatment	0=Warn and continue operation 1=Fault and ramp to stop 2=Fault and coast to stop 3=Warn and operate at last frequency	0	
08	65	PID target value source	0=Frequency command (P00.20, P00.30) 1=P08.66 setting 2=RS-485 communication input 3=External analog input (refer to P03.00) 7=Digital keypad potentiometer dial (GS10 only)	0	
13	00	Application Selection	00=Disabled 01=User parameter 03=Fan 04=Pump 05=Conveyor 07=Packing 10=Logistics 11=Tension PID 12=Tension PID+ Mas/Aus Freq	0	

Multi-function Input Selections		
0=No function 1=Multi-step speed command 1 2=Multi-step speed command 2 3=Multi-step speed command 3 4=Multi-step speed command 4 5=Reset 6=JOG [by external control or GS4-KPD (optional)] 7=Acceleration / deceleration speed inhibit 8=1st and 2nd acceleration / deceleration time selection 9=3rd and 4th acceleration / deceleration time selection 10=External Fault (EF) Input (P07.20) 11=Base Block (B.B.) input from external source 12=Output stop 13=Cancel the setting of auto-acceleration / auto-deceleration time 15=Rotating speed command from AI	18=Force to stop (P07.20) 19=Digital up command 20=Digital down command 21=PID function disabled 22=Clear the counter 23=Input the counter value (DI4) 24=FWD JOG command 25=REV JOG command 28=Emergency stop (EF1) 29=Signal confirmation for Y-connection 30=Signal confirmation for Δ-connection 38=Disable writing EEPROM function 40=Force coasting to stop 41=HAND switch 42=AUTO switch 49=Enable drive 50=Slave dEb action to execute 56=Local / Remote selection	58=Enable fire mode (with RUN command) 59=Enable fire mode (without RUN command) 70=Force auxiliary frequency return to 0 71=Disable PID function, force PID output return to 0 72=Disable PID function, retain the output value before disabled 73=Force PID integral gain return to 0, disable integral 74=Reverse PID feedback 83: Multi-motors (IM) selection bit 0 94: Programmable AUTO RUN 95: Pausing AUTO RUN 97: Multi-pumps switch by Hand / Auto mode 98: Simple positioning stop by forward limit 99: Simple positioning stop by reverse limit

AI Multi-function Input Selections		
0=No function 1=Frequency command	4=PID target value 5=PID feedback signal 6=Thermistor (PTC) input value	11=PT100 RTD input value 12=Auxiliary frequency input 13=PID compensation value

Multi-function Output Selections		
0=No function 1=Indication during RUN 2=Operation speed reached 3=Desired frequency reached 1 (P02.22) 4=Desired frequency reached 2 (P02.24) 5=Zero speed (Frequency command) 6=Zero speed including STOP (Frequency command) 7=Over-torque 1 (P06.06-06.08) 8=Over-torque 2 (P06.09-06.11) 9=Drive is ready 10=Low voltage warning (Lv) (P06.00) 11=Malfunction indication 13=Overheat warning (P06.15) 14=Software brake signal indicator (P07.00) 15=PID feedback error (P08.13, P08.14) 16=Slip error (oSL) 17=Count value reached, does not return to 0 (P02.20) 18=Count value reached, return to 0 (P02.19)	19=External interrupt B.B. input (Base Block) 20=Warning output 21=Over-voltage 22=Over-current stall prevention 23=Over-voltage stall prevention 24=Operation mode 25=Forward command 26=Reverse command 29=Output when frequency ≥ P02.34 30=Output when frequency < P02.34 31=Y-connection for the motor coil 32=Δ-connection for the motor coil 33=Zero speed (actual output frequency) 34=Zero speed including STOP (actual output frequency) 35=Error output selection 1 (P06.23) 36=Error output selection 2 (P06.24) 37=Error output selection 3 (P06.25) 38=Error output selection 4 (P06.26) 40=Speed reached (including STOP)	42=Crane function 43=Motor speed detection 44=Low current output (use with P06.71-06.73) 45=UVW output electromagnetic valve switch 46=Master dEb output 51=Analog output control for RS-485 interface 53=Fire mode indication 67=Analog input level reached 73=Over-torque 3 74=Over-torque 4 75=Forward RUN status 76=Reverse RUN status 77: Program Running Indication 78: Program Step Completed Indication 79: Program Running Completed Indication 80: Program Running Paused Indication 81: Multi-pump system error display (only master)

AO1 Multi-function Output Selections		
0=Output frequency (Hz) 1=Frequency command (Hz) 2=Motor speed (Hz) 3=Output current (rms) 4=Output voltage 5=DC bus voltage	6=Power factor 7=Power 8=Output torque 9=AI 12=lq current command 13=lq feedback value	14=Id current command 15=Id feedback value 16=Vq-axis voltage command 17=Vd-axis voltage command 21=RS-485 analog output 23=Constant voltage output

**COOLING AND HEAT DISSIPATION**

Model Number	Airflow Rate for Cooling		Power Dissipation (Watts)		
	Flow Rate (cfm)	Flow Rate (m <sup>3</sup> /hr)	Loss External (Heat sink)	Internal	Total
GS11N-10P2	0	0	8	10	18
GS11N-10P5			14.2	13.1	27.3
GS11N-20P2			8	10.3	18.3
GS11N-20P5			16.3	14.5	30.8
GS13N-20P2			8.6	10	18.6
GS13N-20P5			16.5	12.6	29.1
GS13N-21P0			31	13.2	44.2
GS13N-40P5			17.6	11.1	28.7
GS13N-41P0			30.5	17.8	48.3
GS11N-21P0			10	16.99	29.1
GS13N-22P0	50.1	24.2			74.3
GS13N-42P0	45.9	21.7			67.6
GS11N-11P0	29.1	23.9			53
GS11N-22P0	46.5	31			77.5
GS11N-23P0	70	35			105
GS13N-23P0	76	30.7			106.7
GS13N-25P0	108.2	40.1			148.3
GS13N-43P0	60.6	22.8			83.4
GS13N-45P0	93.1	42			135.1
GS13N-27P5	23.4	39.7	192.8	53.3	246.1
GS13N-47P5			132.8	39.5	172.3
GS13N-4010			164.7	55.8	220.5

- External Flow Rate is across the heat sink.
- Internal Flow Rate is through the chassis.
- Published flow rates are the result of active cooling using fans, factory installed in the drive.
- Unpublished flow rates (-) are the result of passive cooling in drives without factory installed fans.
- The required airflow shown in the chart is for installing a single GS10 drive in a confined space.
- When installing multiple GS10 drives, the required air volume would be the required air volume for a single GS10 drive multiplied by the number of GS10 drives.
- When calculating power dissipation (Watt Loss), use the Total value. Heat dissipation shown in the chart is for installing a single GS10 drive in a confined space.
- When installing multiple drives, the volume of heat/power dissipation should be the heat/power dissipated by a single GS10 drive multiplied by the number of GS10 drives.
- Heat dissipation for each model is calculated by rated voltage, current and default carrier frequency.

**ENVIRONMENT FOR OPERATION, STORAGE, AND TRANSPORTATION**

DO NOT expose the GS10 drive to environments that contain dust, direct sunlight, corrosive/inflammable gases, high humidity, liquids, or high vibration. The salt in the air must be less than 0.01 mg/cm<sup>2</sup> throughout the year.

Environment	Installation Location	IEC60364-1/IEC60664-1 Pollution degree 2, Indoor use only		
	Surrounding Temperature	Storage: -40°C to +85°C	Transportation: -20°C to +70°C	
		No condensation, non-frozen		
	Rated Humidity	Operation: Max. 90%	Storage/Transportation: Max. 95%	
		No condensed water		
Air Pressure	Operation/Storage: 86 to 106 kPa	Transportation: 70 to 106 kPa		
Pollution Level	IEC60721-3			
	Operation: Class 3C2; Class 3S2	Storage: Class 2C2; Class 2S2	Transportation: Class 1C2; Class 1S2	
Altitude	Operation	If the GS10 drive is installed at altitudes of 0~1000m, follow normal operation restriction. If installed at altitudes of 1000~2000m, decrease 1% of rated current or lower 0.5°C of temperature for every 100m increase in altitude. Maximum altitude for Corner Grounded is 2000m. Contact ADC for more information if you need to use this motor drive at an altitude of 2000m or higher.		
Package Drop	Storage	ISTA procedure 1A (according to weight) IEC60068-2-31		
	Transportation			
Vibration	Operating	1.0mm, peak-to-peak value range from 2Hz to 13.2 Hz; 0.7G~1.0G range from 13.2Hz to 55Hz; 1.0G range from 55Hz to 512 Hz. Comply with IEC 60068-2-6.		
	Non-operating	2.5 G peak, 5Hz~2kHz; 0.015" maximum displacement.		
Impact	Operating	IEC/EN60068-2-27: 15G, 11ms		
	Non-operating	30G		
Protection Level	IP40 - main unit			
	IP20 - wiring area (main circuit terminals and control terminals (all frame types), and the vent near the capacitor on frame C, D, E, and F types).			

**To prevent personal injury, please make sure that the case and wiring are installed according to these instructions. The figures in these instructions are only for reference. They may be slightly different from the one you have, but it will not affect your customer rights.**

**These installation instructions may be revised without prior notice. The most recent edition can be downloaded from the AutomationDirect web site at any time:**  
<http://www.automationdirect.com/static/manuals/index.html>

**MINIMUM MOUNTING CLEARANCES**

When installing your GS10 drive, please keep the following in mind:

- Prevent fiber particles, scraps of paper, shredded wood, saw dust, metal particles, etc., from adhering to the heat sink.
- Install the AC motor drive in a metal cabinet. When installing one drive below another one, use a metal separation between the AC motor drives to prevent mutual heating and to prevent the risk of accidental fire.
- Install the AC motor drive in Pollution Degree 2 environments only: normally only nonconductive pollution occurs and temporary conductivity caused by condensation is expected.

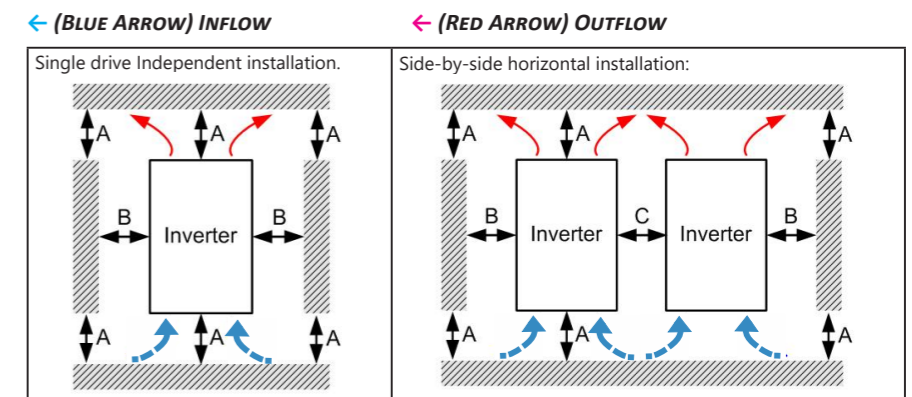

Installation Method	A (mm)	B (mm)	C (mm)	Operation Temperature	
				Max (w/out derating)	Max (Derating)
Single drive installation	50	30	-	50	60
Side-by-side horizontal installation	50	30	30	50	60
Zero stack installation	50	30	0	40	50