

# **INSTALLATION, NETWORK CABLING AND MODULE SPECIFICATIONS**

---



## **In This Chapter...**

Inserting the D0-DCM into the PLC.....	2-2
Building the Communication Cable.....	2-3
Wiring Diagrams.....	2-6
Module Specifications .....	2-8

# Inserting the D0-DCM into the PLC

## D0-DCM Module Installation

Remove the front protective option slot cover by squeezing the pinch tabs and lifting the cover off. Remove the top option slot cover using small flat-head screwdriver or similar device. Be sure PLC power is off when installing the D0-DCM module.

Insert the module into the open slot in the DL05 or into any one of the four slots in the DL06. Locate the module so the printed information is oriented in the same direction as the markings on the PLC. Be careful to align the female connector on the printed circuit board of the module with the male connector on the PLC mother board. Press the module into the slot until the front of the module is flush with the front of the PLC. Check the DL06 power budget to be sure that it remains within the power supply limits before installing more modules.

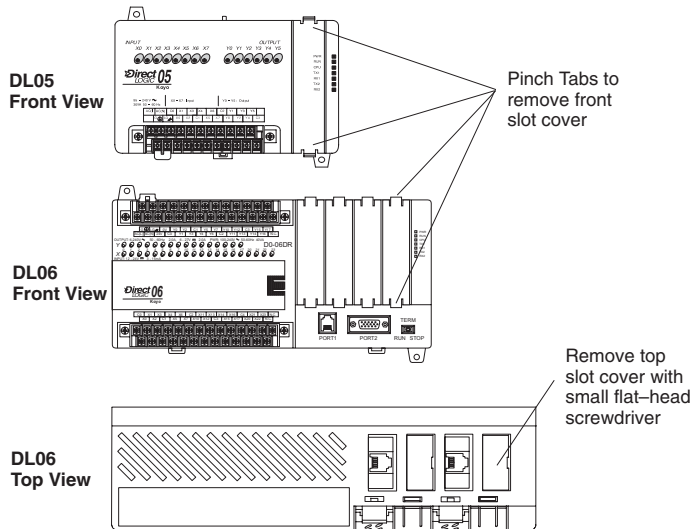

Insert the module into the open slot in the DL05 or into any one of the four slots in the DL06. Locate the module so the printed information is oriented in the same direction as the markings on the PLC. Be careful to align the female connector on the printed circuit board of the module with the male connector on the PLC mother board. Press the module into the slot until the front of the module is flush with the front of the PLC. Check the DL06 power budget to be sure that it remains within the power supply limits before installing more modules.

## PLC Firmware and DirectSOFT Requirements



**NOTE:** The DL05 CPU's communication feature for the D0-DCM requires DirectSOFT32 Version 3.0c (or later) and firmware version 5.00 (or later). The DL06 requires DirectSOFT32 version V4.0, build 16 (or later) and firmware version 1.90 (or later). See our web site for firmware information and downloads: [www.automationdirect.com](http://www.automationdirect.com)

## Building the Communication Cable

There are several considerations that help determine the type of cable needed for your D0–DCM application. The next few pages discuss these considerations in detail.

### Consideration 1: Physical Configuration

The D0–DCM can be used in either a point-to-point or multi-drop configuration. A point-to-point connection only has two stations, a master and a slave. Use the point-to-point configuration to connect a PC, an operator interface, or an intelligent device to a single D0–DCM. You also use this configuration when you connect a *DirectNET* or (Modbus RTU) master station to a single *DirectNET* or (Modbus RTU) slave station, respectfully.

#### Point to Point – RS–232

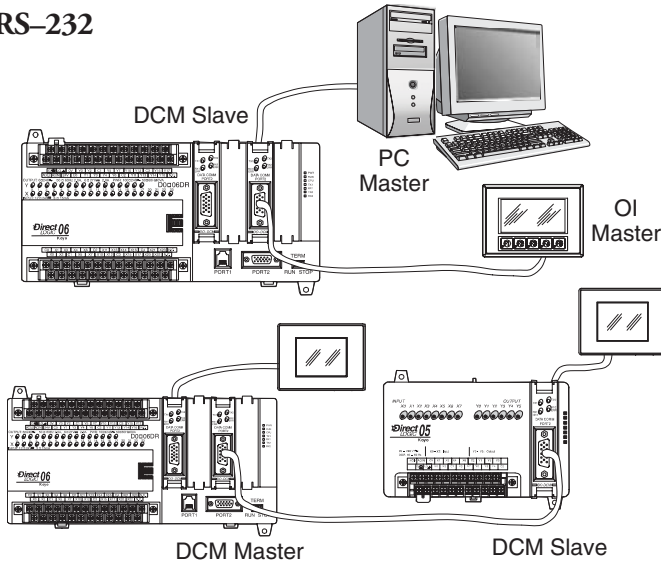

Use the multi-drop configuration to connect one master to two or more slaves.

#### Multi-drop – RS–422/485

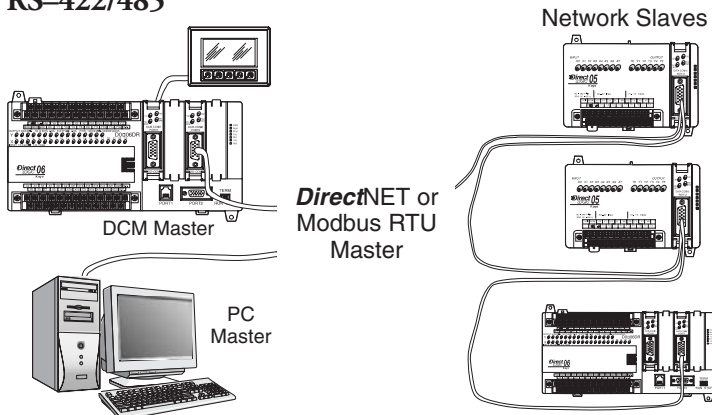

### Consideration 2: Electrical Specification RS232C or RS422/485

The D0-DCM can support RS-232 (ports 1 and 2) or RS-422/485 (port 2) communication. Your application and configuration choice will help determine which electrical specification is best for you. If you are using multi-drop, you must use RS-422 or RS-485. If you are using point-to-point, you may choose between RS-232, RS-422 or RS-485.

You can use RS-232 if the cable length is less than 50 feet and if the cable will not be subjected to induced electrical noise that is commonly found near welders, large motors, or other devices that create large magnetic fields.

You must use RS-422/485 for all other applications. RS-422/485 allows longer cable distances (up to 3300 feet) and provides higher noise immunity.

Although the network configuration and electrical specification are important, the type of devices being connected to the D0-DCM are just as important. The exact cable schematic needed really depends on a combination of all three things.

The following diagram shows the port pinouts for the D0-DCM.

### Consideration 3: Cable Schematics

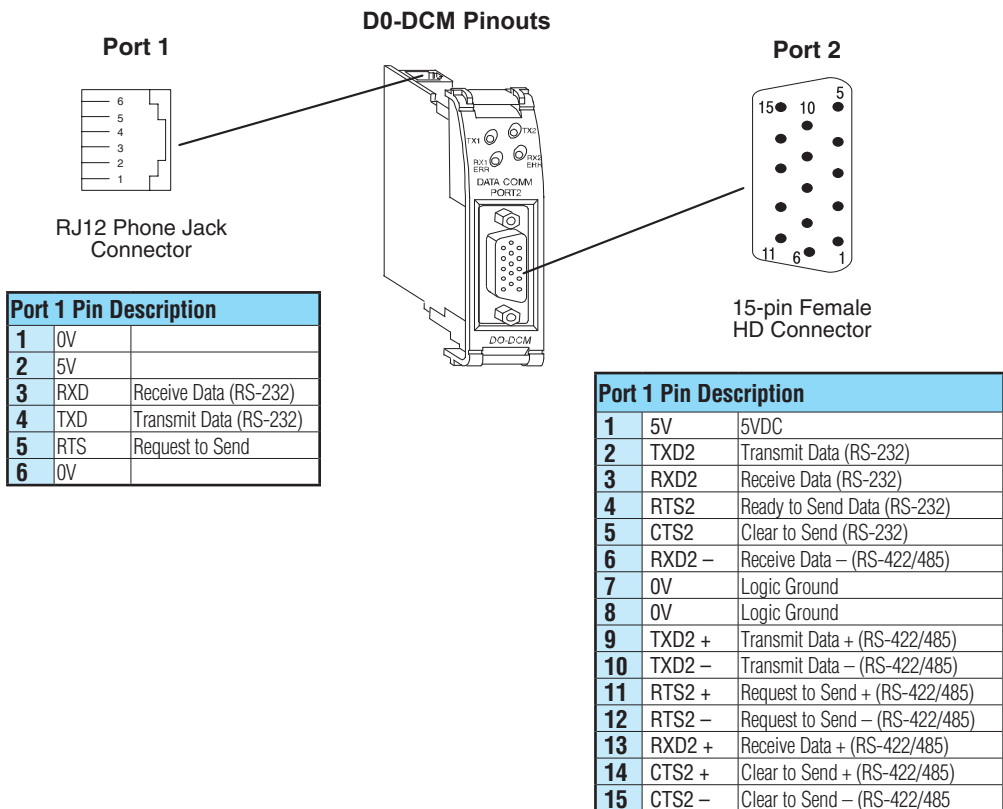

### Consideration 4: Cable Specifications

Although many types of cables may work for your application, we recommend you use a cable that is constructed to offer a high degree of noise immunity. The following specifications are to be used as a guideline.

Structure . . . . .	Shielded, twisted-pair (RS232 only uses two wires and a ground)
Conductor size . . . . .	24AWG or larger
Insulation . . . . .	Polyethylene
Shield . . . . .	Copper braid or aluminum foil
Impedance . . . . .	100Q @ 1MHz
Capacitance . . . . .	60pf / meter or less

### Consideration 5: Installation Guidelines

Your company may have guidelines for cable installation. If so, you must check those before you begin the installation. Here are some general things to consider.

- Don't run cable next to larger motors, high current switches, or transformers. This may cause noise problems.
- Route the cable through an approved cable housing to minimize the risk of accidental cable damage. Check local and national codes to choose the correct method for your application.
- Consider redundant cabling if the application data is critical. This allows you to quickly reconnect all stations while the primary cable is being repaired.

**Cable Shield Grounding** — It is important to ground the cable shield to minimize the possibility of noise. The preferred method is to connect one end of the cable shield to the connector housing. If noise problems are still present and you have a good earth ground for the cabinet, you must connect one end of the shield to the cabinet earth ground. Don't ground both ends of the shield because this will create induced noise on the cable.

**Step 1: Strip back about 2.5" of the shield.**

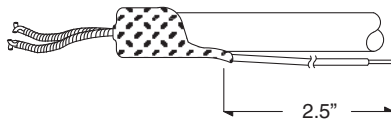

**Step 2: Crimp a ring connector onto the shield.**

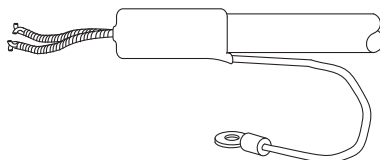

**Step 3: Secure the shield to the connector shell.**

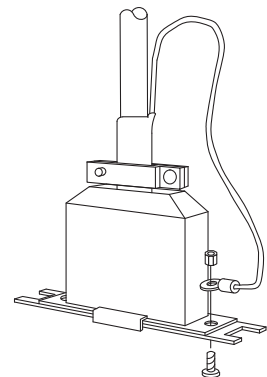

# Wiring Diagrams

**D0-DCM Port 1  
RS-232 Network**

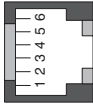

6-pin Female Modular Connector

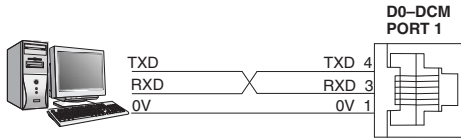

**D0-DCM Port 2  
RS-232 Network**

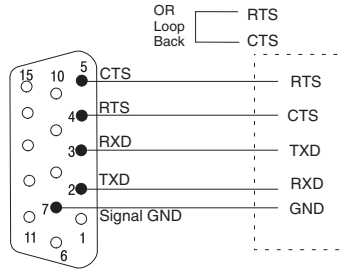

**D0-DCM Port 2  
RS-485 Network**

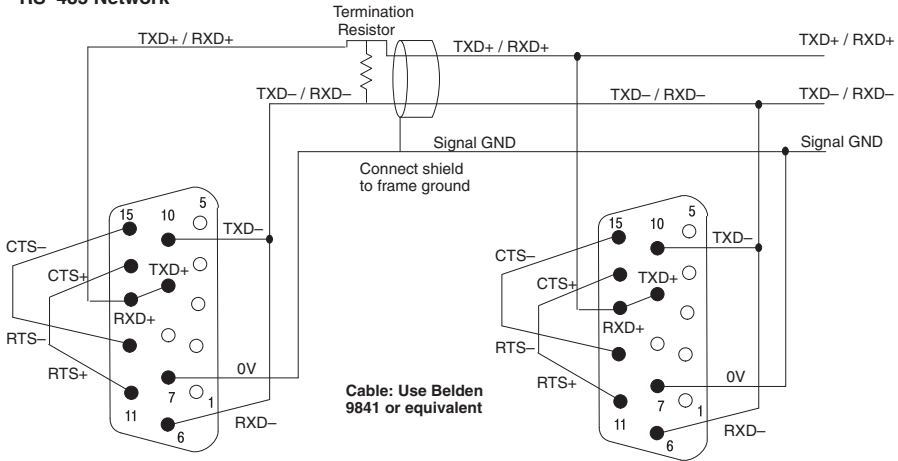

## D0-DCM Port 2

### RS-422 Network

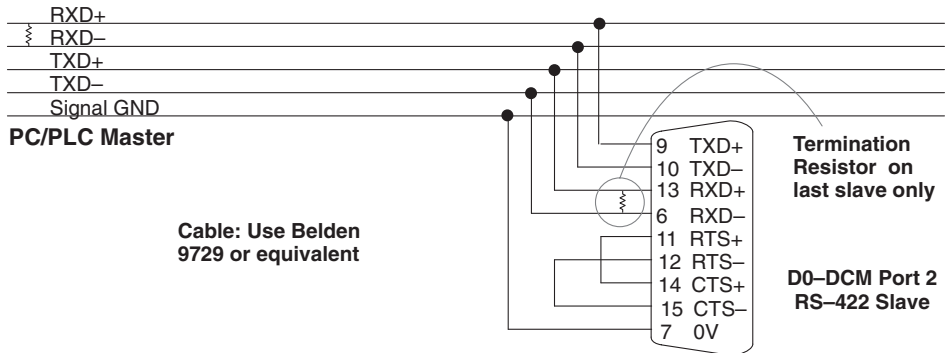

**RS-422/485 Multi-drop Termination Resistors** — It is important you add termination resistors at each end of the RS422/485 line. This helps reduce data errors during data transmission. You must select resistors that match the cable impedance. For example, a typical 22AWG solid conductor cable with 4.5 twists per foot has a typical impedance of about 120 ohm.

There are two ways to connect the resistors:

- **Line-to-Line** — this method balances the receive data lines (IN+ and IN-) and requires one resistor at each end of the line. (The cable diagrams we've provided show this method, but you can use either).
- **Line-to-Ground** — this method also balances the receive data lines, but common mode noise rejection is improved significantly. This method requires two resistors at each end of the line. Also, since there are two resistors, the sum total of both resistors must match the cable impedance.

# Module Specifications

## General Specifications

General Specifications	
Power Budget Requirement	250mA @ 5VDC (Not including external 5VDC consumption)
Maximum Number of Modules	DL05: 1; DL06: 4
Operating Temperature	32°F to 131°F (0°C to 55°C)
Storage Temperature	-4°F to 158°F (-20°C to 80°C)
Operating Humidity	5 to 95% (non-condensing)
Air Composition	No corrosive gases permitted
Vibration	MIL STD 810C, Method 514.2
Shock	MIL STD 810C, Method 516.2
Voltage Isolation	1000VAC, 1 minute duration
Insulation Resistance	10M ohms at 500VDC
Noise Immunity	NEMA ICS3-304, UL, CE, (FCC Class A) Class 1, Division 2 (C1D2)
Weight	1.75 oz. (50g)

## Port 1 Specifications

Connector	6-pin Female Modular (RJ12)
Communications	RS-232
Protocol (auto-detection)	<i>Direct</i> Net slave K-sequence slave Modbus RTU slave
Station Number	0-247
Communication Data	8 data bits, 1 start bit, 1 stop bit (fixed)
Parity Bit	None, Odd
Baud Rates	9600, 19200, 38400, 57600, 115200 bps
Transmit Mode	ASCII, Hex
Maximum Distance	RS-232: 50ft (15 meters)

Port 1



RJ12 Phone Jack Connector

Port 1 Pin Description		
1	0V	
2	5V	
3	RXD	Receive Data (RS-232)
4	TXD	Transmit Data (RS-232)
5	RTS	Request to Send
6	0V	



Port 2 Specifications

<b>Connector</b>	<b>15-pin Female Modular (RJ12)</b>
<b>Communications</b>	RS-232 RS-422/485
<b>Protocol (auto-detection)</b>	<i>DirectNet</i> slave K-sequence slave Modbus RTU slave Non-sequence (ASCII IN/OUT)
<b>Station Number</b>	0–247
<b>Communication Data</b>	8/7 data bits, 1 start bit, 1/2 stop bit (fixed)
<b>Parity Bit</b>	None, Odd
<b>Baud Rates</b>	300, 600, 1200, 4800, 9600, 19200, 38400, 57600, 115200 bps
<b>Transmit Mode</b>	ASCII, Hex
<b>Communications Time-out</b>	Base time x (1–50)
<b>Response Delay Time</b>	0/2/5/10/20/50/100/500ms
<b>Character Time-out</b>	0–9999ms
<b>Maximum Distance</b>	RS–232: 50ft (15m) RS422/485 – 1000m

Port 1 Pin Description		
1	5V	5VDC
2	TXD2	Transmit Data (RS-232)
3	RXD2	Receive Data (RS-232)
4	RTS2	Ready to Send Data (RS-232)
5	CTS2	Clear to Send (RS-232)
6	RXD2 –	Receive Data – (RS-422/485)
7	0V	Logic Ground
8	0V	Logic Ground
9	TXD2 +	Transmit Data + (RS-422/485)
10	TXD2 –	Transmit Data – (RS-422/485)
11	RTS2 +	Request to Send + (RS-422/485)
12	RTS2 –	Request to Send – (RS-422/485)
13	RXD2 +	Receive Data + (RS-422/485)
14	CTS2 +	Clear to Send + (RS-422/485)
15	CTS2 –	Clear to Send – (RS-422/485)

Port 2

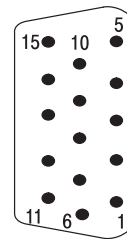

15-pin Female HD Connector

Indicator	State		Definition
<b>TXT</b>	ON	Green	Port 1 transmitting data
<b>RX1 (ERR)</b>	ON	Green	Port 1 receiving data
	ON	Red	Port 1 Timeout, NAK or Exception Response
<b>TXT2</b>	ON	Green	Port 2 transmitting data
<b>RX2 (ERR)</b>	ON	Green	Port 2 receiving data
	ON	Red	Port 2 Timeout, NAK or Exception Response