

GETTING STARTED



CHAPTER 1

In This Chapter...

Introduction.....	1-2
Conventions Used.....	1-3
DL06 Micro PLC Overview.....	1-4
I/O Quick Selection Guide.....	1-5
Quick Start	1-6
Steps to Designing a Successful System	1-10
Questions and Answers about DL06 Micro PLCs.....	1-12

Introduction

The Purpose of this Manual

Thank you for purchasing a DL06 Micro PLC. This manual shows you how to install, program, and maintain all PLCs in the DL06 family. It also helps you understand how to interface them to other devices in a control system. This manual contains important information for personnel who will install DL06 PLCs and for the PLC programmer. This user manual will provide the information you need to get and keep your system up and running.

Supplemental Manuals

The D0-OPTIONS-M manual contains technical information about the option cards available for the DL06 PLCs. This information includes specifications and wiring diagrams that will be indispensable if you use any of the optional I/O or communications cards. If you have purchased one of our operator interface panels or *DirectSOFT*[™] programming software, you will want to refer to the manuals that are written for these products.

Technical Support

We strive to make our manuals the best in the industry. We rely on your feedback to let us know if we are reaching our goal. If you cannot find the solution to your particular application, or, if for any reason you need technical assistance, please call us at

770-844-4200

Our technical support group will work with you to answer your questions. They are available Monday through Friday from 9:00 A.M. to 6:00 P.M. Eastern Time. We also encourage you to visit our web site where you can find technical and non-technical information about our products and our company.

<http://www.automationdirect.com>

If you have a comment, question or suggestion about any of our products, services, or manuals, please fill out and return the **Suggestions** card included with this manual.

Conventions Used



When you see the notepad icon in the left-hand margin, the paragraph to its immediate right will be a **special note**. Notes represent information that may make your work quicker or more efficient.

The word **NOTE** in boldface type will mark the beginning of the text.



When you see the exclamation point icon in the left-hand margin, the paragraph to its immediate right will be a **warning**. This information could prevent injury, loss of property, or even death in extreme cases. Any warning in this manual should be regarded as critical information that should be read in its entirety.

The word **WARNING** in boldface type will mark the beginning of the text.

Key Topics for Each Chapter

The beginning of each chapter will list the key topics that can be found in that chapter.

Getting Started	
	 CHAPTER 1
In This Chapter...	
General Information	1-2
Specifications	1-4

DL06 Micro PLC Overview

The DL06 micro PLC family is a versatile product line that combines powerful features and a very compact footprint. The DL06 PLCs offer expandable I/O, high-speed counter, floating point, PID, etc. There are a number of communication options and an optional LCD display.

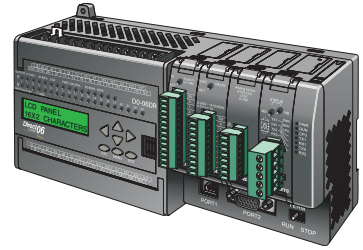

The DL06 PLC Features

The DL06 Micro PLC family includes nine different versions. All have the same appearance and CPU performance. The CPU offers an instruction set very similar to our powerful new DL260 CPU including new easy to use ASCII and MODBUS instructions. All DL06 PLCs have two built-in communications ports that can be used for programming, operator interface, networking, etc.

Units with DC inputs have selectable high-speed input features on four input points. Units with DC outputs offer selectable pulse output capability on the first and second output points. Details of these features and more are covered in Chapter 3, CPU Specifications and Operation. There are nine versions of the DL06 PLC. The most common industrial I/O types and power supply voltages are available. Consult the following table to find the model number of the PLC that best fits your application.

DL06 Micro PLC Family					
DL06 Part Number	Discrete Input Type	Discrete Output Type	External Power	High-Speed Input	Pulse Output
DO-06AA	AC	AC	95-240 VAC	No	No
DO-06AR	AC	Relay	95-240 VAC	No	No
DO-06DA	DC	AC	95-240 VAC	Yes	No
DO-06DD1	DC	DC Sinking	95-240 VAC	Yes	Yes
DO-06DD2	DC	DC Sourcing	95-240 VAC	Yes	Yes
DO-06DR	DC	Relay	95-240 VAC	Yes	No
DO-06DD1-D	DC	DC Sinking	12-24 VDC	Yes	Yes
DO-06DD2-D	DC	DC Sourcing	12-24 VDC	Yes	Yes
DO-06DR-D	DC	Relay	12-24 VDC	Yes	No

DirectSOFT Programming for Windows™

The DL06 Micro PLC can be programmed with *DirectSOFT*, a Windows-based software package that supports familiar features such as cut-and-paste between applications, point-and-click editing, viewing and editing multiple application programs at the same time, floating views, intelligent boxes, etc. Firmware version 2.10 is needed in order to use the intelligent boxes.

DirectSOFT (part number PC-D $SOFT_x$) supports the *DirectLOGIC* CPU families. You can use *DirectSOFT* 5 to program the DL05, DL06, DL105, DL205, DL305, and DL405 CPUs. A separate manual discusses *DirectSOFT* programming software. Earlier programming software versions such as *DirectSOFT*32, version 4.0 can also be used to program the DL06.

Handheld Programmer

All DL06 Micro PLCs have a built-in programming port for use with the handheld programmer (D2–HPP), the same programmer used with the DL05, DL105 and DL205 families. The handheld programmer can be used to create, modify and debug your application program. A separate manual discusses the Handheld Programmer. Only D2–HPPs with firmware version 2.0 or later will program the DL06.



NOTE: Not all instructions are available to use with the HPP - the real number instructions, for example. *DirectSOFT* will be needed to program instructions such as these.

I/O Quick Selection Guide

The nine versions of the DL06 have input/output circuits which can interface to a wide variety of field devices. In several instances a particular input or output circuit can interface to either DC or AC voltages, or both sinking and sourcing circuit arrangements. Check this guide to find the proper DL06 Micro PLC to interface to the field devices in your application.

I/O Selection Guide						
DL06 Part Number	INPUTS			OUTPUTS		
	I/O type/commons	Sink/Source	Voltage Ranges	I/O type/commons	Sink/Source	Voltage/ Current Ratings*
DO-06AA	AC / 5	–	90 – 120 VAC	AC / 4	–	17 – 240 VAC, 50/60 Hz 0.5A
DO-06AR	AC / 5	–	90 – 120 VAC	Relay / 4	Sink or Source	6 – 27VDC, 2A 6 – 240 VAC, 2A
DO-06DA	DC / 5	Sink or Source	12 – 24 VDC	AC / 4	–	17 – 240 VAC, 50/60 Hz 0.5A
DO-06DD1	DC / 5	Sink or Source	12 – 24 VDC	DC / 4	Sink	6 – 27 VDC, 0.5A (Y0–Y1) 6 – 27 VDC, 1.0A (Y2–Y17)
DO-06DD2	DC / 5	Sink or Source	12 – 24 VDC	DC / 4	Source	12 – 24 VDC, 0.5A (Y0–Y1) 12 – 24 VDC, 1.0A (Y2–Y17)
DO-06DR	DC / 5	Sink or Source	12 – 24 VDC	Relay / 4	Sink or Source	6 – 27VDC, 2A 6 – 240 VAC, 2A
DO-06DD1-D	DC / 5	Sink or Source	12 – 24 VDC	DC / 4	Sink	6 – 27 VDC, 0.5A (Y0–Y1) 6 – 27 VDC, 1.0A (Y2–Y17)
DO-06DD2-D	DC / 5	Sink or Source	12 – 24 VDC	DC / 4	Source	12 – 24 VDC, 0.5A (Y0–Y1) 12 – 24 VDC, 1.0A (Y2–Y17)
DO-06DR-D	DC / 5	Sink or Source	12 – 24 VDC	Relay / 4	Sink or Source	6 – 27 VDC, 2A 6 – 240 VAC, 2A

* See Chapter 2, Specifications for more information about a particular DL06 version.

Quick Start

This example is not intended to tell you everything you need to know about programming and starting up a complex control system. It is only intended to give you an opportunity to demonstrate to yourself and others the basic steps necessary to power up the PLC and confirm its operation. Please look for warnings and notes throughout this manual for important information you will not want to overlook.

Step 1: Unpack the DL06 Equipment

Unpack the DL06 and gather the parts necessary to build this demonstration system. The recommended components are:

- DL06 Micro PLC
- AC power cord or DC power supply
- Toggle switches (see Step 2 on next page)
- Hook-up wire, 16-22 AWG
- DL06 User Manual (this manual)
- A small screwdriver, 5/8" flat or #1 Philips type

You will need at least one of the following programming options:

- *DirectSOFT* Programming Software V5.0 or later (PC-D SOFTx), *DirectSOFT* Programming Software Manual (included with the software), and a programming cable (D2-DSCBL connects the DL06 to a personal computer).
- D2-HPP Handheld Programmer, firmware version 2.0 or later, (comes with programming cable). Please purchase Handheld Programmer Manual D2-HPP-M separately.

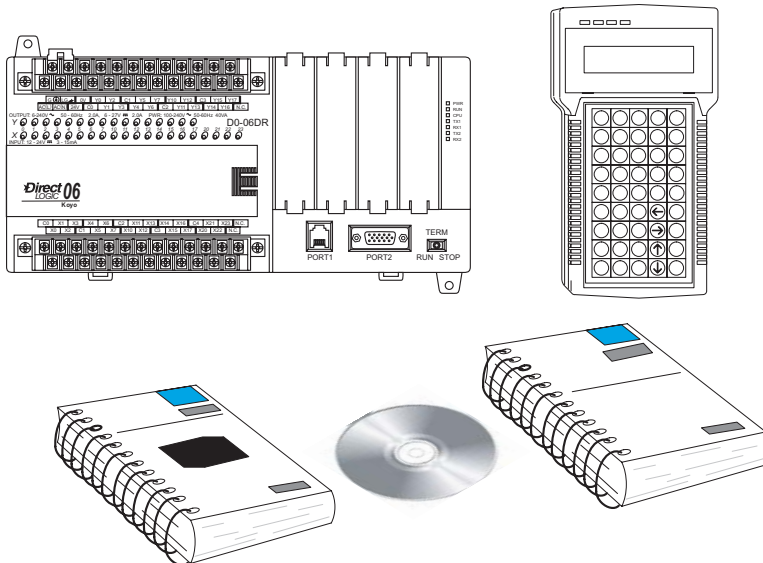

Step 2: Connect Switches to Input Terminals

To proceed with this quick-start exercise or to follow other examples in this manual, you will need to connect one or more input switches as shown below. If you have DC inputs on an AC-supply DL06, you can use the auxiliary 24VDC supply on the output terminal block or other external 12-24VDC power supply. Be sure to follow the instructions in the accompanying **WARNING** on this page.

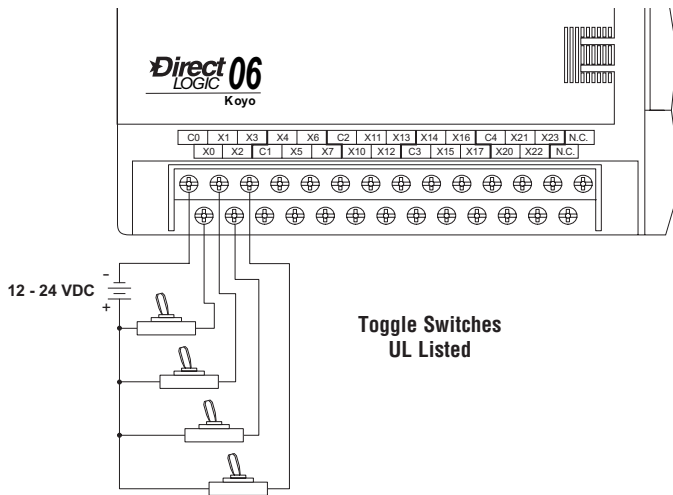

**D0-06DA, D0-06DD1,
D0-06DD2, D0-06DR,
D0-DD1-D, and D0-06DR1-D
DC Input**

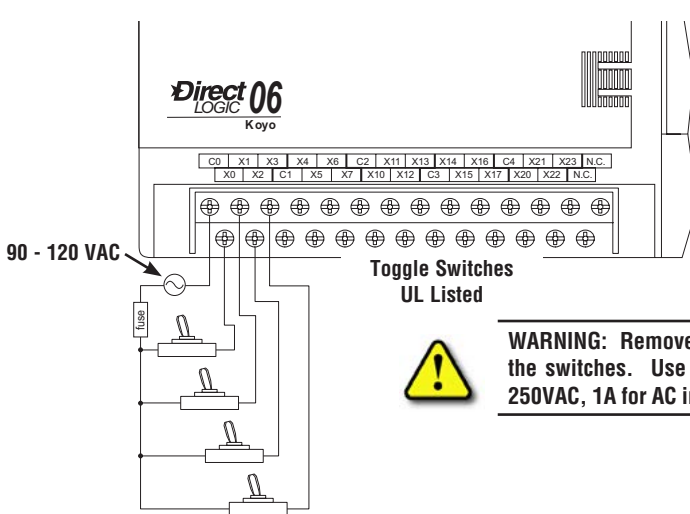

**D0-06AA and D0-06AR
AC input only**



WARNING: Remove power and unplug the DL06 when wiring the switches. Use only UL-approved switches rated for at least 250VAC, 1A for AC inputs. Firmly mount the switches before using.

Step 3: Connect the Power Wiring

Connect the power input wiring for the DL06. Observe all precautions stated earlier in this manual. For more details on wiring, see Chapter 2 on Installation, Wiring, and Specifications. When the wiring is complete, close the connector covers. Do not apply power at this time.

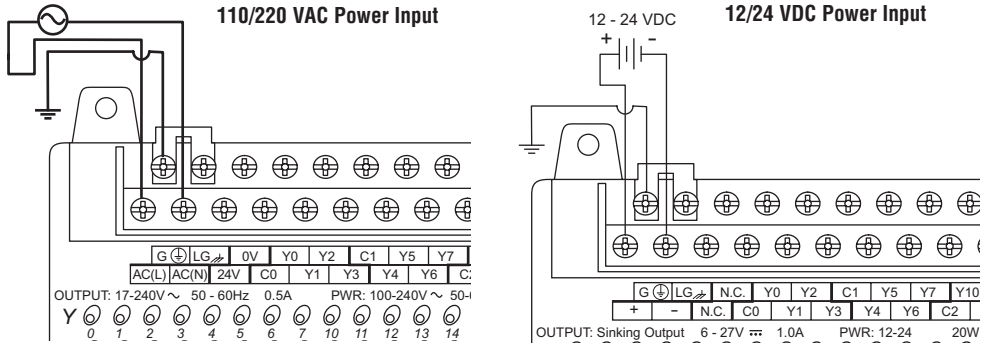

Step 4: Connect the Programming Device

Most programmers will use *DirectSOFT* programming software, installed on a personal computer. An alternative, if you need a compact portable programming device, is the Handheld Programmer (firmware version 2.20 or later). Both devices will connect to COM port 1 of the DL06 via the appropriate cable.

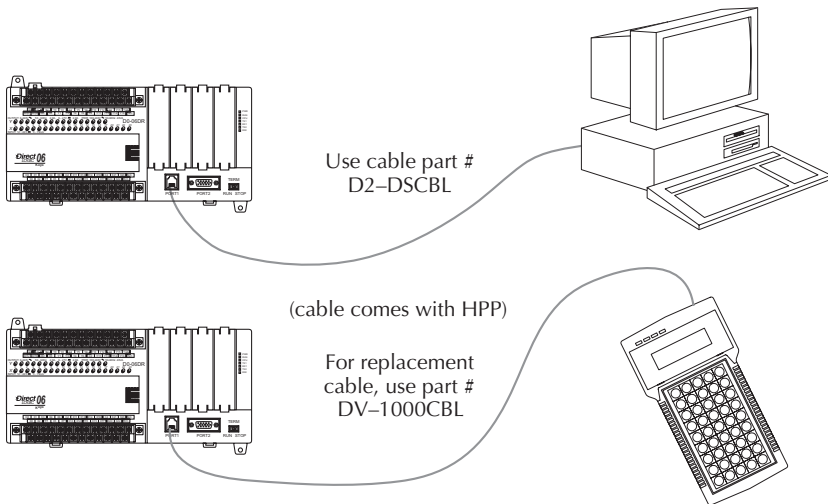

NOTE: The Handheld Programmer cannot create or access LCD, ASCII or MODBUS instructions.

Step 5: Switch on the System Power

Apply power to the system and ensure the PWR indicator on the DL06 is on. If not, remove power from the system and check all wiring and refer to the troubleshooting section in Chapter 9 for assistance.

Step 6: Initialize Scratchpad Memory

It's a good precaution to always clear the system memory (scratchpad memory) on a new DL06. There are two ways to clear the system memory:

- In *DirectSOFT*, select the PLC menu, then Setup and Initialize Scratch Pad. Initializing Scratch Pad will return secondary comm port settings and retentive range settings to default. If you have made any changes to these, you will need to note these changes and re-enter them after initializing Scratchpad.
- For the Handheld Programmer, use the AUX key and execute AUX 54.

See the Handheld Programmer Manual for additional information.

Step 7: Enter a Ladder Program

At this point, *DirectSOFT* programmers need to refer to Chapter 2 (Quick Start) in the *DirectSOFT* Programming Software Manual. There you will learn how to establish a communications link with the DL06 PLC, change CPU modes to Run or Program, and enter a program.

If you are learning how to program with the Handheld Programmer, make sure the CPU is in Program Mode (the RUN LED on the front of the DL06 should be off). If the RUN LED is on, use the MODE key on the Handheld Programmer to put the PLC in Program Mode, then switch to TERM.

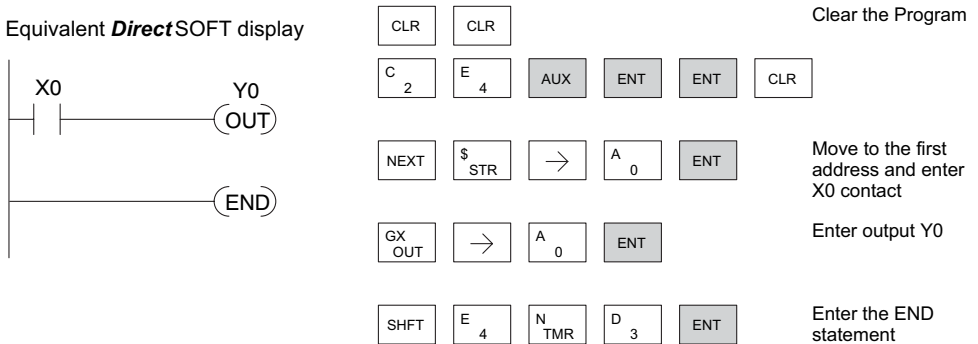

Enter the following keystrokes on the Handheld Programmer.

After entering the simple example program, put the PLC in Run mode by using the Mode key on the Handheld Programmer.

The RUN indicator on the PLC will illuminate, indicating the CPU has entered the Run mode. If not, repeat this step, ensuring the program is entered properly or refer to the troubleshooting guide in chapter 9.

After the CPU enters the run mode, the output status indicator for Y0 should follow the switch status on input channel X0. When the switch is on, the output will be on.

Steps to Designing a Successful System

Step 1: Review the Installation Guidelines

Always make safety the first priority in any system design. Chapter 2 provides several guidelines that will help you design a safer, more reliable system. This chapter also includes wiring guidelines for the various versions of the DL06 PLC.

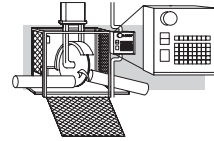

Step 2: Understand the PLC Setup Procedures

The PLC is the heart of your automation system. Make sure you take time to understand the various features and setup requirements.

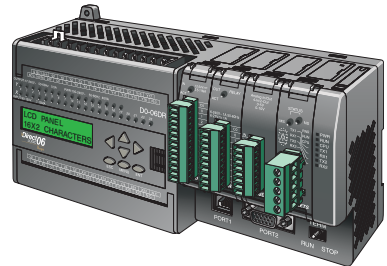

Step 3: Review the I/O Selection Criteria

There are many considerations involved when you select your I/O type and field devices. Take time to understand how the various types of sensors and loads can affect your choice of I/O type.

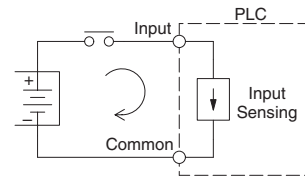

Step 4: Choose a System Wiring Strategy

It is important to understand the various system design options that are available before wiring field devices and field-side power supplies to the Micro PLC.

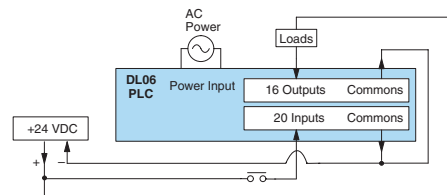

Step 5: Understand the System Operation

Before you begin to enter a program, it is very helpful to understand how the DL06 system processes information. This involves not only program execution steps, but also involves the various modes of operation and memory layout characteristics.

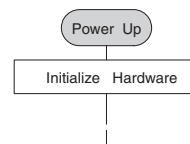

Step 6: Review the Programming Concepts

The DL06 PLC instruction set provides for three main approaches to solving the application program, depicted in the figure below.

- RLL diagram-style programming is the best tool for solving boolean logic and general CPU register/accumulator manipulation. It includes dozens of instructions, which will also be needed to augment drums and stages.
- The Timer/Event Drum Sequencer features up to 16 steps and offers both time and/or event-based step transitions. The DRUM instruction is best for a repetitive process based on a single series of steps.
- Stage programming (also called RLLplus) is based on state-transition diagrams. Stages divide the ladder program into sections which correspond to the states in a flow chart you draw for your process.

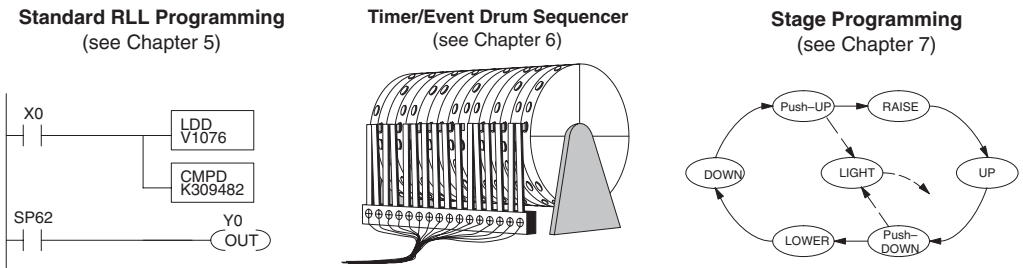

After reviewing the programming concepts above, you'll be equipped with a variety of tools to write your application program.

Step 7: Choose the Instructions

Once you have installed the Micro PLC and understand the main programming concepts, you can begin writing your application program. At that time you will begin to use one of the most powerful instruction sets available in a small PLC.

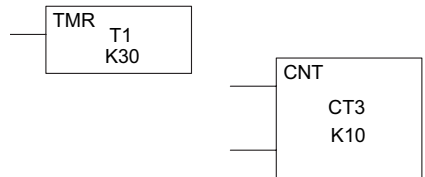

Step 8: Understand the Maintenance and Troubleshooting Procedures

Sometimes equipment failures occur when we least expect it. Switches fail, loads short and need to be replaced, etc. In most cases, the majority of the troubleshooting and maintenance time is spent trying to locate the problem. The DL06 Micro PLC has many built-in features, such as error codes, that can help you quickly identify problems.

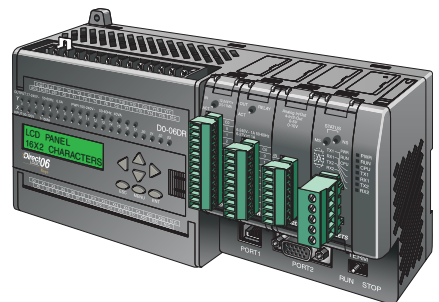

Questions and Answers about DL06 Micro PLCs

Q. What is the instruction set like?

A. The instruction set is very close to that of our DL260 CPU. The DL06 instructions include the drum sequencing instruction, networking, ASCII, MODBUS, LCD, intelligent boxes and High-Speed I/O capabilities. High-Speed inputs are available on units with DC inputs only; high-speed outputs are available on units with DC outputs only.

Q. Do I have to buy the full DirectSOFT programming package to program the DL06?

A. Yes. The part number for *DirectSOFT* (PC-DSOFT6) is now used for all PLCs in the *DirectLOGIC* family, and the price is very affordable.

Q. Is the DL06 expandable?

A. Yes, the DL06 series function as stand-alone PLCs. However, option card slots allow you to expand the system without changing the footprint.

Q. Does the DL06 have motion control capability?

A. Yes, the DL06 has limited motion control capabilities. The High-Speed I/O features offer either encoder inputs with high-speed counting and presets with interrupt, or a pulse/direction output for stepper control. Three types of motion profiles are available, which are explained in Appendix E. The H0-CTRIO(2) option module can also be used to provide more motion functionality.

Q. Are the ladder programs stored in a removable EEPROM?

A. No. The DL06 contains a non-removable FLASH memory for program storage, which may be written and erased thousands of times. You may transfer programs to/from *DirectSOFT* on a PC.

Q. Does the DL06 contain fuses for its outputs?

A. There are no output circuit fuses. Therefore, we recommend fusing each channel, or fusing each common. See Chapter 2 for I/O wiring guidelines.

Q. Is the DL06 Micro PLC UL approved?

A. The Micro PLC has met the requirements of UL (Underwriters' Laboratories, Inc.) and CUL (Canadian Underwriters' Laboratories, Inc.). See our website, www.Automationdirect.com, for complete details.

Q. Does the DL06 Micro PLC comply with European Union (EU) Directives?

A. The Micro PLC has met the requirements of the European Union Directives (CE). See our website, www.Automationdirect.com, for complete details.

Q. Which devices can I connect to the communication ports of the DL06?

A. Port 1: The port is RS-232C, fixed at 9600 baud, odd parity, address 1, and uses the proprietary K-sequence protocol. The DL06 can also connect to MODBUS RTU and DirectNET networks as a slave device through port 1. The port communicates with the following devices:

- DV-1000 Data Access Unit, C-more, DirectTouch, LookoutDirect, DSData or Optimization Operator interface panels
- *DirectSOFT* (running on a personal computer)
- D2-HPP handheld programmer
- Other devices which communicate via K-sequence, DirectNET, MODBUS RTU protocols should work with the DL06 Micro PLC. Contact the vendor for details.

A. Port 2: This is a multi-function port. It supports RS-232C, RS422, or RS485, with selective baud rates (300–38400 bps), address and parity. It also supports the proprietary K-sequence protocol, as well as *DirectNet* and MODBUS RTU, ASCII In/Out, and non-sequence/print protocols.

Q. Can the DL06 accept 5VDC inputs?

A. No. 5 volts is lower than the DC input ON threshold. However, many TTL logic circuits can drive the inputs if they are wired as open collector (sinking) inputs. See Chapter 2 for I/O wiring guidelines.