

# SPECIFICATIONS



## CONTENTS OF THIS CHAPTER

<i>Available Models</i> . . . . .	.2-2
<i>Model Specifications</i> . . . . .	.2-3
<i>Specifications common to all models</i> . . . . .	2-4
<i>CM5-T4W Specifications</i> . . . . .	2-5
<i>CM5-T7W Specifications</i> . . . . .	2-6
<i>CM5-T10W and CM5-T12W Specifications</i> . . . . .	2-7
<i>CM5-T15W and CM5-T22W Specifications</i> . . . . .	2-8
<i>Dimensions, Ports and Memory Expansion</i> . . . . .	.2-9
<i>CM5-T4W Dimensions</i> . . . . .	2-9
<i>CM5-T4W Ports and Memory Expansion</i> . . . . .	.2-10
<i>CM5-T7W Dimensions</i> . . . . .	.2-11
<i>CM5-T7W Ports and Memory Expansion</i> . . . . .	.2-12
<i>CM5-T10W Dimensions</i> . . . . .	.2-13
<i>CM5-T12W Dimensions</i> . . . . .	.2-14
<i>CM5-T15W Dimensions</i> . . . . .	.2-15
<i>CM5-T22W Dimensions</i> . . . . .	.2-16
<i>CM5-T10W, CM5-T12W, CM5-T15W and CM5-T22W Ports and Memory Expansion</i> . . . . .	.2-17
<i>Mounting Clearances</i> . . . . .	.2-18
<i>Communication Ports</i> . . . . .	.2-19
<i>Ethernet Port</i> . . . . .	.2-19
<i>USB Type B Port</i> . . . . .	.2-19
<i>USB Type A Port</i> . . . . .	.2-20
<i>Serial Communication Ports</i> . . . . .	.2-20
<i>User Defined LED</i> . . . . .	.2-21
<i>Handling External Memory Devices</i> . . . . .	.2-22
<i>Writing to External Memory devices</i> . . . . .	.2-22
<i>Memory Device Formatting</i> . . . . .	.2-22
<i>Minimizing Data Errors</i> . . . . .	.2-23
<i>Monitoring Available Memory</i> . . . . .	.2-23
<i>Power Loss Retention</i> . . . . .	.2-24
<i>Chemical Compatibility</i> . . . . .	.2-24

## AVAILABLE MODELS

The **C-more**® Operator Interface is the next generation of touch panel brought to you by AutomationDirect. It has been designed to display and interchange graphical data from a PLC by merely viewing or touching the screen.

The **C-more** Touch Panel is available in a variety of models to suit your application. Refer to the following tables for a list of part numbers, descriptions and options available.

Part Number	Description	Project Memory	SD Card Slot	USB Port	Ethernet	RJ12 RS-232	DB-15 RS-232 RS-422 RS-485	3-wire TB RS-485	Audio Out
<b>CM5-T4W</b>	<b>C-more</b> CM5 series touch screen HMI, 4.3in color TFT LCD, analog resistive, widescreen, 480 x 272 pixel, WQVGA, LED backlight, (1) Ethernet, (2) serial and (2) USB ports and (1) memory card slot.	45MB	1 Slot	2 Port	1 Port***	Yes	Yes	No*	No**
<b>CM5-T7W</b>	<b>C-more</b> CM5 series touch screen HMI, 7in color TFT LCD, analog resistive, widescreen, 800 x 480 pixel, WVGA, LED backlight, (1) Ethernet, (2) serial and (2) USB ports and (1) memory card slot.	45MB	1 Slot	2 Port	1 Port***	Yes	Yes	No*	No**
<b>CM5-T10W</b>	<b>C-more</b> CM5 series touch screen HMI, 10.1in color TFT LCD, analog resistive, widescreen, 1024 x 600 pixel, WSVGA, LED backlight, (2) Ethernet, (3) serial and (4) USB ports and (1) memory card slot.	90MB	1 Slot	4 Ports	2 Ports	Yes	Yes	1 Port	No**
<b>CM5-T12W</b>	<b>C-more</b> CM5 series touch screen HMI, 12.1in color TFT LCD, analog resistive, widescreen, 1280 x 800 pixel, WXGA, LED backlight, (2) Ethernet, (3) serial and (4) USB ports and (1) memory card slot.	90MB	1 Slot	4 Ports	2 Ports	Yes	Yes	1 Port	No**
<b>CM5-T15W</b>	<b>C-more</b> CM5 series touch screen HMI, 15.6in color TFT LCD, analog resistive, widescreen, 1366 x 768 pixel, HD, LED backlight, (2) Ethernet, (3) serial and (4) USB ports and (1) memory card slot.	90MB	1 Slot	4 Ports	2 Ports	Yes	Yes	1 Port	No**
<b>CM5-T22W</b>	<b>C-more</b> CM5 series touch screen HMI, 21.5in color TFT LCD, analog resistive, widescreen, 1920 x 1080 pixel, FHD, LED backlight, (2) Ethernet, (3) serial and (4) USB ports and (1) memory card slot.	90MB	1 Slot	4 Ports	2 Ports	Yes	Yes	1 Port	No**

\*Use ADC part number USB-485M or the 15-pin D-sub RS-485 port.  
 \*\* Use standard USB to audio adapter.  
 \*\*\* Use a standard USB to Ethernet adapter to add a second Ethernet port.

## MODEL SPECIFICATIONS

The following specification tables are separated into these groups:

- *Specifications common to all models*
- *4-inch model CM5-T4W*
- *7-inch model, CM5-T7W*
- *10-inch and 12-inch models, CM5-T10W and CM5-T12W*
- *15-inch and 22-inch models, CM5-T15W and CM5-T22W*

**Specification tables begin on the next page**

**SPECIFICATIONS COMMON TO ALL MODELS**

<b>Specification</b>	<b>Model</b>	<b>All Models</b>
<b>Operating Temperature</b>		0 to 50 °C (32 to 122 °F); Maximum surrounding air temperature rating: 50 °C (122 °F) IEC 60068-2-14 (Test Nb, Thermal Shock)
<b>Altitude</b>		Up to 2000m (6562 ft)
<b>Storage Temperature</b>		-20 to +60 °C (-4 to +140 °F) IEC 60068-2-1 (Test Ab, Cold) IEC 60068-2-2 (Test Bb, Dry Heat) IEC 60068-2-14 (Test Na, Thermal Shock)
<b>Humidity</b>		5-95% RH (non-condensing)
<b>Environment</b>		For use in Pollution Degree 2 environment, no corrosive gases permitted
<b>Noise Immunity</b>		(EN61131-2) EN61000-4-2 (ESD), EN61000-4-3 (RFI) EN61000-4-4 (FTB) EN61000-4-5 (Surge) EN61000-4-6 (Conducted) EN61000-4-8 (Power frequency magnetic field immunity)  (Local Test) RFI, (145MHz, 440Mhz 10W @ 10cm) Impulse 1000V @ 1µs pulse
<b>Withstand Voltage</b>		1000 VAC, 1 min. (FG to Power supply)
<b>Insulation Resistance</b>		> 10M ohm @ 500V DC (FG to Power supply)
<b>Vibration</b>		IEC60068-2-6 (Test Fc)
<b>Shock</b>		IEC60068-2-27 (Test Ea)
<b>Emission</b>		EN55011 Class A (Radiated RF emission)
<b>Enclosure</b>		NEMA 250 type 4/4X indoor use only UL50 type 4X indoor use only IP65 indoor use only (not tested by UL) (When mounted correctly)
<b>Backlight Average Lifetime*</b>		50,000 hours @ 25 °C
<b>Touch Panel Type**</b>		Four-wire analog resistive
<b>Supply Power</b>		10.2-26.4 VDC Class2 or SELV (Safety Extra-Low Voltage) Circuit / Limited Energy Circuit (LIM) Reverse Polarity Protected



\*NOTE: The backlight average lifetime is defined as the average usage time it takes before the brightness becomes 50% of the initial brightness. The lifetime of the backlight depends on the ambient temperature. The lifetime will decrease under low or high temperature usage.



\*\*NOTE: The Touchscreen is designed to respond to a single touch. If it is touched at multiple points at the same time, an unexpected object may be activated.

**CM5-T4W SPECIFICATIONS**

Specification	Model	CM5-T4W
<b>Description</b>		<b>C-more</b> CM5 series touch screen HMI, 4.3in color TFT LCD, analog resistive, widescreen, 480 x 272 pixel, WQVGA, LED backlight, (1) Ethernet, (2) serial and (2) USB ports and (1) memory card slot.
<b>Display Actual Size and Type</b>		4.3" TFT color
<b>Display Viewing Area</b>		3.74" x 2.12" [95.0 mm x 53.9 mm]
<b>Cutout Dimensions</b>		4.02" x 2.76" [102.1 mm x 70.1 mm]
<b>Weight</b>		0.46 lb (210g)
<b>Screen Pixel</b>		480 x 272 (WQVGA)
<b>Display Brightness</b>		310 nits (typ)
<b>LCD Panel Dot Pitch</b>		0.198 mm x 0.198 mm
<b>Color Scale</b>		16.7 M
<b>Project Memory</b>		45MB
<b>Retentive Memory</b>		198KB Internal Log Buffer for Trends, alarms and messages, 32KB Retentive Tags, 79KB Alarm counts and history. Backed up for 30 days at 25 C after power has been applied for 24 hours
<b>Number of Screens</b>		Up to 999 screens – limited by project memory
<b>Realtime Clock</b>		Realtime Clock Built into panel, backed up for 30 days at 25°C after power has been applied for 24 hours
<b>Calendar - Month / Day / Year</b>		Yes - monthly deviation 60 sec at 25°C
<b>Serial Port 1</b>		15-pin D-sub female - RS232C, RS-422/485
<b>Serial Port 2</b>		RJ-12 modular jack - RS-232C
<b>Serial Port 3</b>		N/A
<b>USB Port - Type B</b>		USB 2.0 High speed (480 Mbps) Type B - Download/Program Max cable length - 15 ft.
<b>USB Port - Type A</b>		USB 2.0 High speed (480 Mbps) Type A - for USB device options Max cable length - 15ft Bus Power – Less than 500mA at 5VDC
<b>Ethernet Port</b>		Ethernet Port Ethernet 10/100 Base-T, auto MDI/MDI-X
<b>SD Card Slot</b>		1 slot. Supports max 2 GB (SD), max 32 GB (SDHC)
<b>Power Consumption</b>		8.0 W 0.67 A @ 12 VDC 0.33 A @ 24 VDC
<b>Internal Fuse (non-replaceable)</b>		4A
<b>Agency Approvals</b>		UL UL 61010-1, UL 61010-2-201 (UL File No. E157382) cUL CAN/CSA C22.2 No. 61010-1, No. 61010-2-201 CE EMC: 2014/30/EU (EN 61131-2) RoHS: 2011/65/EU, (EU) 2015/863 (EN IEC 63000)

**CM5-T7W SPECIFICATIONS**

<b>Specification</b>	<b>Model</b>	<b>CM5-T7W</b>
<b>Description</b>		<b>C-more</b> CM5 series touch screen HMI, 7in color TFT LCD, analog resistive, widescreen, 800 x 480 pixel, WVGA, LED backlight, (1) Ethernet, (2) serial and (2) USB ports and (1) memory card slot.
<b>Display Actual Size and Type</b>		7.0" TFT color
<b>Display Viewing Area</b>		6.07" x 3.38" [154.08 mm x 85.92 mm]
<b>Cutout Dimensions</b>		7.46" x 5.51" [189.5 mm x 140.0 mm]
<b>Weight</b>		1.36 lb (615g)
<b>Screen Pixel</b>		800 x 480 (WVGA)
<b>Display Brightness</b>		310 nits (typ)
<b>LCD Panel Dot Pitch</b>		0.1926 mm x 0.179 mm
<b>Color Scale</b>		16.7 M
<b>Project Memory</b>		45MB
<b>Retentive Memory</b>		198KB Internal Log Buffer for Trends, alarms and messages, 32KB Retentive Tags, 79KB Alarm counts and history. Backed up for 30 days at 25 C after power has been applied for 24 hours
<b>Number of Screens</b>		Up to 999 screens – limited by project memory
<b>Realtime Clock</b>		Realtime Clock Built into panel, backed up for 30 days at 25°C after power has been applied for 24 hours
<b>Calendar - Month / Day / Year</b>		Yes - monthly deviation 60 sec at 25°C
<b>Serial Port 1</b>		15-pin D-sub female - RS232C, RS-422/485
<b>Serial Port 2</b>		RJ-12 modular jack - RS-232C
<b>Serial Port 3</b>		N/A
<b>USB Port - Type B</b>		USB 2.0 High speed (480 Mbps) Type B - Download/Program Max cable length - 15 ft.
<b>USB Port - Type A</b>		USB 2.0 High speed (480 Mbps) Type A - for USB device options Max cable length - 15ft Bus Power – Less than 500mA at 5VDC
<b>Ethernet Port</b>		Ethernet Port Ethernet 10/100 Base-T, auto MDI/MDI-X
<b>SD Card Slot</b>		1 slot. Supports max 2 GB (SD), max 32 GB (SDHC)
<b>Power Consumption</b>		10.0 W 0.83 A @ 12 VDC 0.42 A @ 24 VDC
<b>Internal Fuse (non-replaceable)</b>		4A
<b>Agency Approvals</b>		UL UL 61010-1, UL 61010-2-201 (UL File No. E157382) cUL CAN/CSA C22.2 No. 61010-1, No. 61010-2-201 CE EMC: 2014/30/EU (EN 61131-2) RoHS: 2011/65/EU, (EU) 2015/863 (EN IEC 63000)

**CM5-T10W AND CM5-T12W SPECIFICATIONS**

Specification	Model	CM5-T10W	CM5-T12W
<b>Description</b>		<b>C-more</b> CM5 series touch screen HMI, 10.1in color TFT LCD, analog resistive, widescreen, 1024 x 600 pixel, WSVGA, LED backlight, (2) Ethernet, (3) serial and (4) USB ports and (1) memory card slot.	<b>C-more</b> CM5 series touch screen HMI, 12.1in color TFT LCD, analog resistive, widescreen, 1280 x 800 pixel, WXGA, LED backlight, (2) Ethernet, (3) serial and (4) USB ports and (1) memory card slot.
<b>Display Actual Size and Type</b>		10.1" TFT color	12.0" TFT color
<b>Display Viewing Area</b>		8.77" x 4.93" [222.7 mm x 125.3 mm]	10.28" x 6.43" [261.1 mm x 163.2 mm]
<b>Cutout Dimensions</b>		9.25" x 7.07" [235.0 mm x 179.6 mm]	11.91" x 8.92" [302.5 mm x 226.6 mm]
<b>Weight</b>		2.29 lb (1,040g)	3.44 lb (1,560g)
<b>Screen Pixel</b>		1024 x 600 (WSVGA)	1200 x 800 (WXGA)
<b>Display Brightness</b>		315 nits (typ)	280 nits (typ)
<b>LCD Panel Dot Pitch</b>		0.2175 mm x 0.2088 mm	0.2040 mm x 0.2040 mm
<b>Color Scale</b>		16.7 M	
<b>Project Memory</b>		90MB	
<b>Retentive Memory</b>		198KB Internal Log Buffer for Trends, alarms and messages, 32KB Retentive Tags, 79KB Alarm counts and history. Backed up for 30 days at 25 C after power has been applied for 24 hour	
<b>Number of Screens</b>		Up to 999 screens – limited by project memory	
<b>Realtime Clock</b>		Realtime Clock Built into panel, backed up for 30 days at 25°C after power has been applied for 24 hours	
<b>Calendar - Month / Day / Year</b>		Yes - monthly deviation 60 sec at 25°C	
<b>Serial Port 1</b>		15-pin D-sub female - RS232C, RS-422/485	
<b>Serial Port 2</b>		RJ-12 modular jack - RS-232C	
<b>Serial Port 3</b>		3-wire terminal block - RS-485	
<b>USB Port - Type B</b>		USB 2.0 High speed (480 Mbps) Type B - Download/Program Max cable length - 15 ft.	
<b>USB Port - Type A</b>		3 ports. USB 2.0 High speed (480 Mbps) Type A - for USB device options Max cable length - 15ft Bus Power – Less than 500mA each (less than 1500mA total) at 5VDC	
<b>Ethernet Port</b>		2 ports. Ethernet Port Ethernet 10/100 Base-T, auto MDI/MDI-X	
<b>SD Card Slot</b>		1 slot. Supports max 2 GB (SD), max 32 GB (SDHC) 2TB (SDXC)	
<b>Power Consumption</b>		21.0 W 1.75 A @ 12 VDC 0.88 A @ 24 VDC	35.0 W 2.92 A @ 12 VDC 1.46 A @ 24 VDC
<b>Internal Fuse (non-replaceable)</b>		12.0 A	
<b>Agency Approvals</b>		UL UL 61010-1, UL 61010-2-201 (UL File No. E157382) cUL CAN/CSA C22.2 No. 61010-1, No. 61010-2-201 CE EMC: 2014/30/EU (EN 61131-2) RoHS: 2011/65/EU, (EU) 2015/863 (EN IEC 63000)	

**CM5-T15W AND CM5-T22W SPECIFICATIONS**

<b>Specification</b>	<b>Model</b>	<b>CM5-T15W</b>	<b>CM5-T22W</b>
<b>Description</b>		<b>C-more</b> CM5 series touch screen HMI, 15.6in color TFT LCD, analog resistive, widescreen, 1366 x 768 pixel, HD, LED backlight, (2) Ethernet, (3) serial and (4) USB ports and (1) memory card slot.	<b>C-more</b> CM5 series touch screen HMI, 21.5in color TFT LCD, analog resistive, widescreen, 1920 x 1080 pixel, FHD, LED backlight, (2) Ethernet, (3) serial and (4) USB ports and (1) memory card slot.
<b>Display Actual Size and Type</b>		15.6" TFT color	21.5" TFT colot
<b>Display Viewing Area</b>		13.55" x 7.62" [344.2 mm x 193.5 mm]	19.00" x 11.00" [476.1 mm x 267.8 mm]
<b>Cutout Dimensions</b>		15.40" x 10.47" [391.9 mm x 265.9 mm]	20.74" x 13.57" [526.8 mm x 344.7 mm]
<b>Weight</b>		5.51 lb (2,500g)	12.88 lb (5,840g)
<b>Screen Pixel</b>		1366 x 768 (HD)	1920 x 1080 (FHD)
<b>Display Brightness</b>		280 nits (typ)	
<b>LCD Panel Dot Pitch</b>		0.252 mm x 0.252 mm	0.24795 mm x 0.24795 mm
<b>Color Scale</b>		16.7 M	
<b>Project Memory</b>		90MB	
<b>Retentive Memory</b>		198KB Internal Log Buffer for Trends, alarms and messages, 32KB Retentive Tags, 79KB Alarm counts and history. Backed up for 30 days at 25 C after power has been applied for 24 hour	
<b>Number of Screens</b>		Up to 999 screens – limited by project memory	
<b>Realtime Clock</b>		Realtime Clock Built into panel, backed up for 30 days at 25°C after power has been applied for 24 hours	
<b>Calendar - Month / Day / Year</b>		Yes - monthly deviation 60 sec at 25°C	
<b>Serial Port 1</b>		15-pin D-sub female - RS232C, RS-422/485	
<b>Serial Port 2</b>		RJ-12 modular jack - RS-232C	
<b>Serial Port 3</b>		3-wire terminal block - RS-485	
<b>USB Port - Type B</b>		USB 2.0 High speed (480 Mbps) Type B - Download/Program Max cable length - 15 ft.	
<b>USB Port - Type A</b>		3 ports. USB 2.0 High speed (480 Mbps) Type A - for USB device options Max cable length - 15ft Bus Power – Less than 500mA each (less than 1500mA total) at 5VDC	
<b>Ethernet Port</b>		2 ports. Ethernet Port Ethernet 10/100 Base-T, auto MDI/MDI-X	
<b>SD Card Slot</b>		1 slot. Supports max 2 GB (SD), max 32 GB (SDHC) 2TB (SDXC)	
<b>Power Consumption</b>		35.0 W 2.92 A @ 12 VDC 1.46 A @ 24 VDC	40.0 W 3.33 A @ 12 VDC 1.67 A @ 24 VDC
<b>Internal Fuse (non-replaceable)</b>		12.0 A	
<b>Agency Approvals</b>		UL UL 61010-1, UL 61010-2-201 (UL File No. E157382) cUL CAN/CSA C22.2 No. 61010-1, No. 61010-2-201 CE EMC: 2014/30/EU (EN 61131-2) RoHS: 2011/65/EU, (EU) 2015/863 (EN IEC 63000)	



**DIMENSIONS, PORTS AND MEMORY EXPANSION**

**CM5-T4W DIMENSIONS**

All the necessary mounting hardware is provided with the touch panel. Use the two mounting clips and screws to secure the touch panel to the cabinet or enclosure surface.

Use the dimensional drawing below for cutout dimensions.

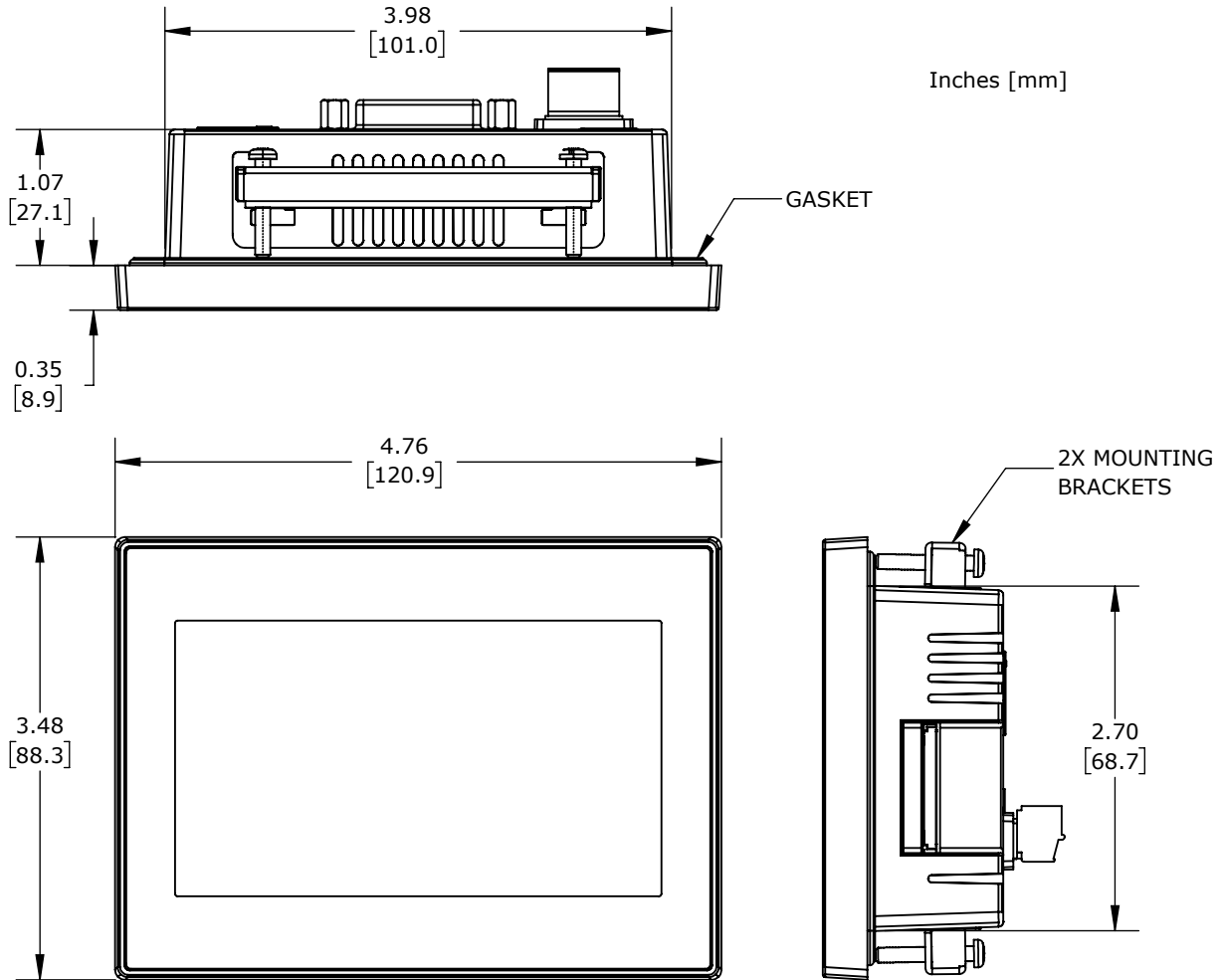

**Enclosure Mounting Thickness Ranges and Mounting Clip Screw Torque**

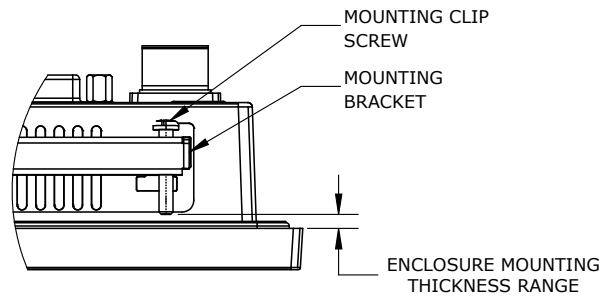

Touch Panel Size	Enclosure Thickness Range	Mounting Clip Screw Torque	Material
4-inch	0.039 - 0.20 inch [1 - 5 mm]	21 - 28 oz-in [0.15 - 0.20 Nm]	Metal
7-inch through 22-inch		135 - 149 oz-in [0.95 - 1.05 Nm]	

CM5-T4W PORTS AND MEMORY EXPANSION

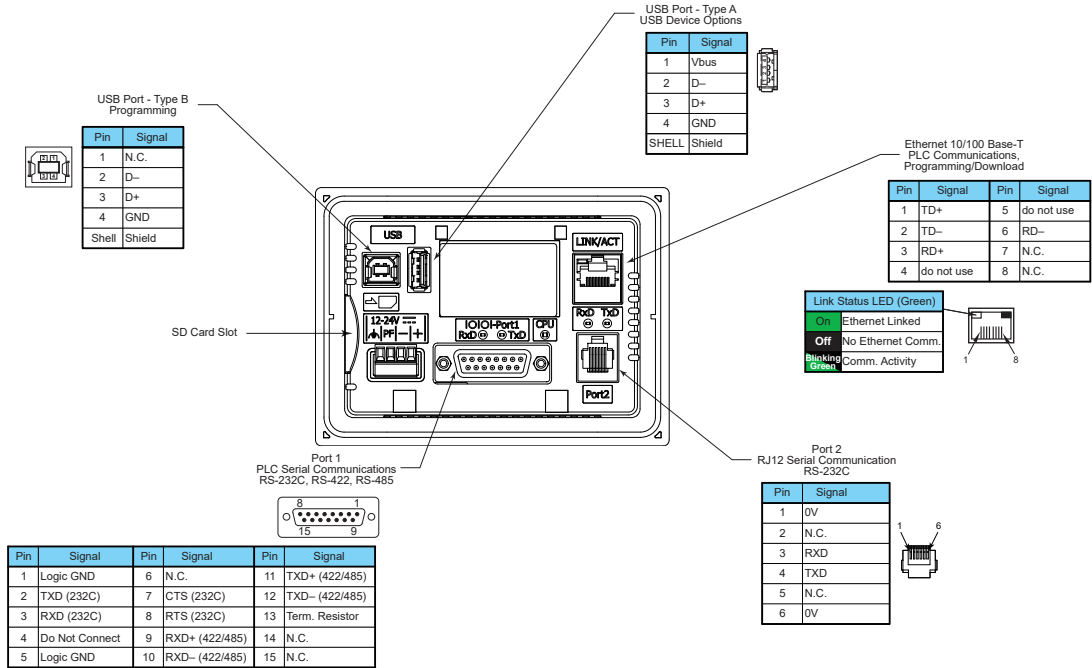

**CM5-T7W DIMENSIONS**

All the necessary mounting hardware is provided with the touch panel. Use the four mounting clips and screws to secure the touch panel to the cabinet or enclosure surface.

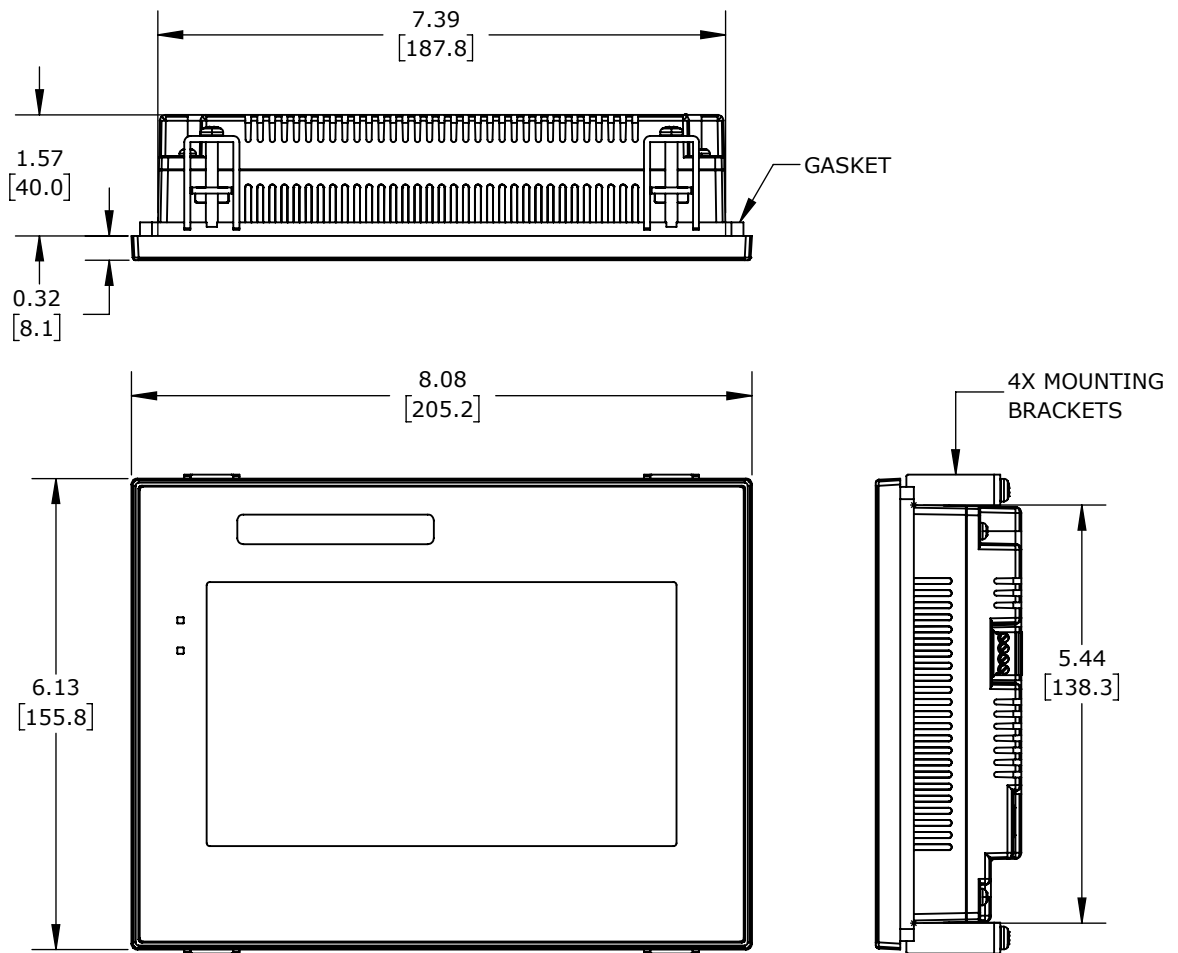

**Enclosure Mounting Thickness Ranges and Mounting Clip Screw Torque**

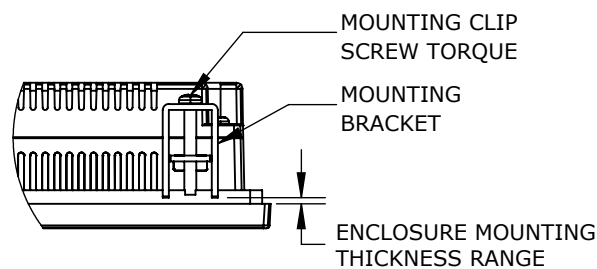

Touch Panel Size	Enclosure Thickness Range	Mounting Clip Screw Torque	Material
4-inch	0.039 - 0.20 inch [1 - 5 mm]	21 - 28 oz-in [0.15 - 0.20 Nm]	Metal
7-inch through 22-inch		135 - 149 oz-in [0.95 - 1.05 Nm]	

CM5-T7W PORTS AND MEMORY EXPANSION

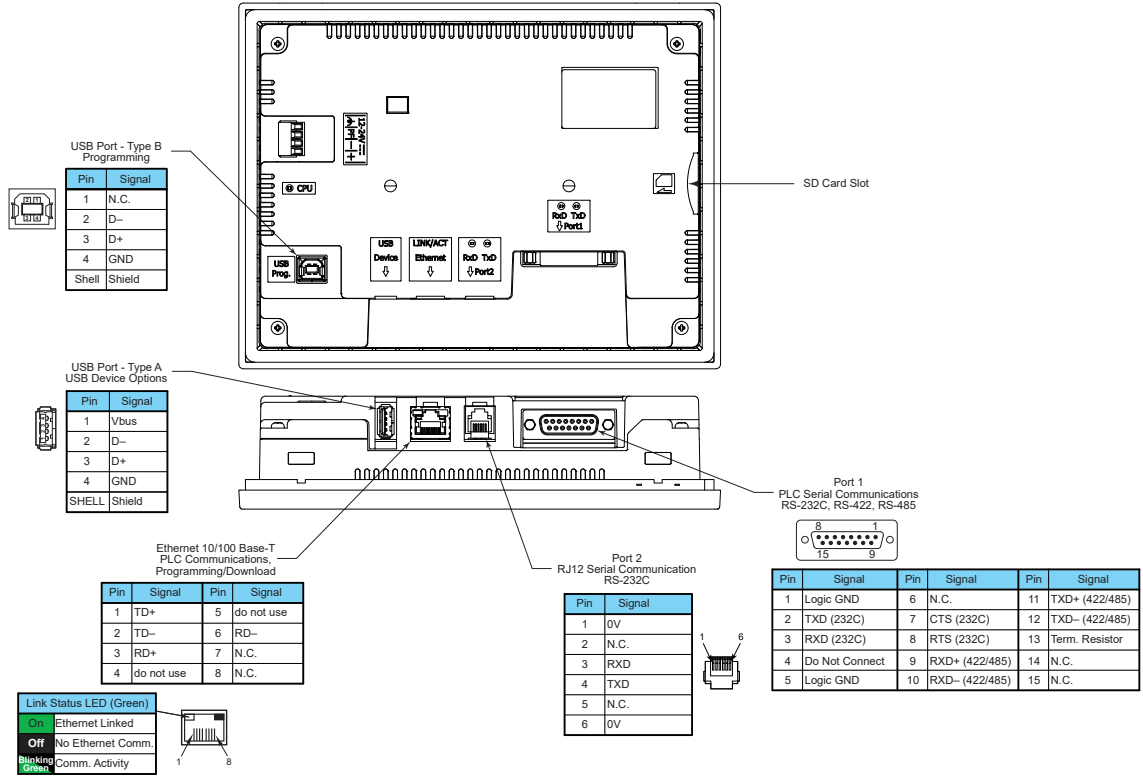

**CM5-T10W DIMENSIONS**

All the necessary mounting hardware is provided with the touch panel. Use the four mounting clips and screws to secure the touch panel to the cabinet or enclosure surface.

A template for marking the cutout dimensions on the mounting surface is provided in the box.

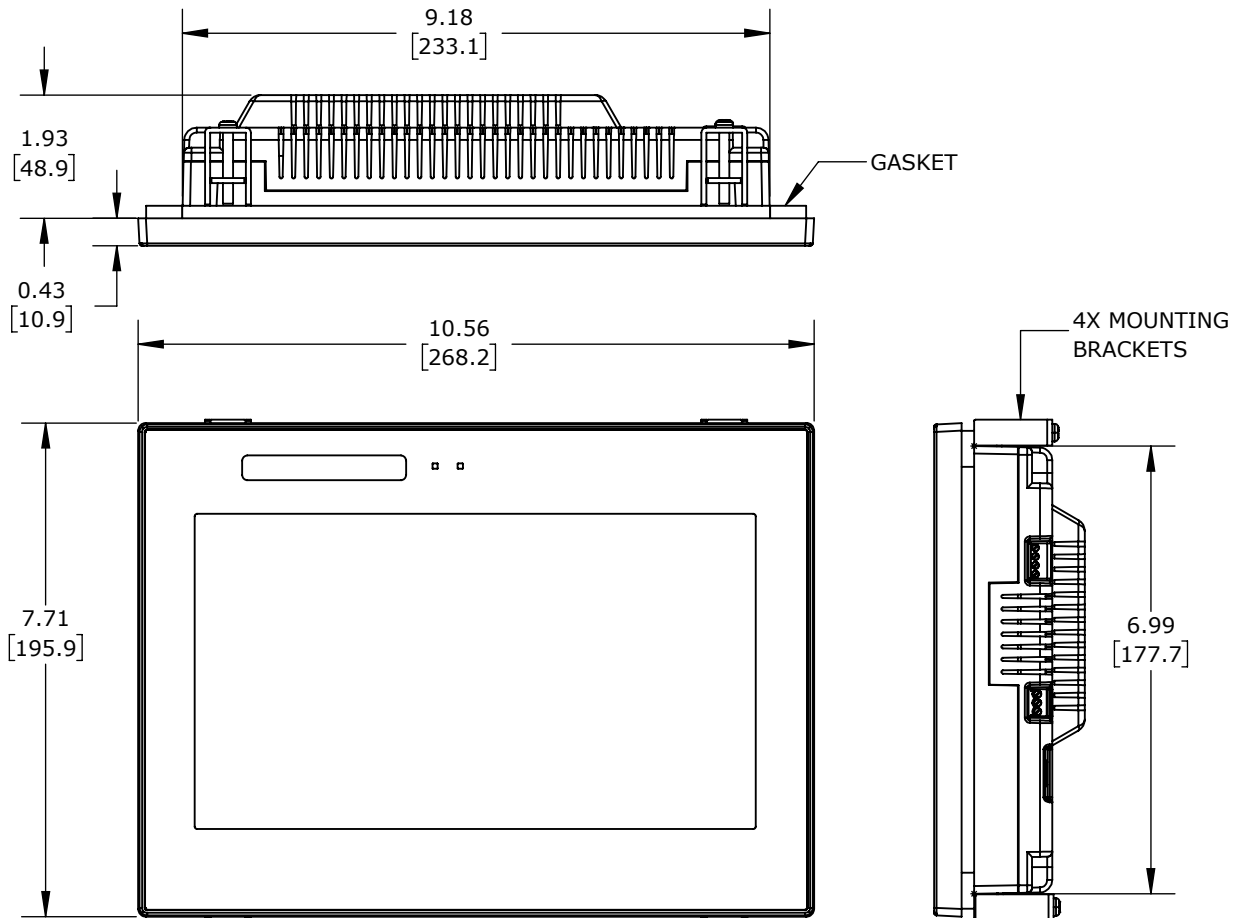

**Enclosure Mounting Thickness Ranges and Mounting Clip Screw Torque**

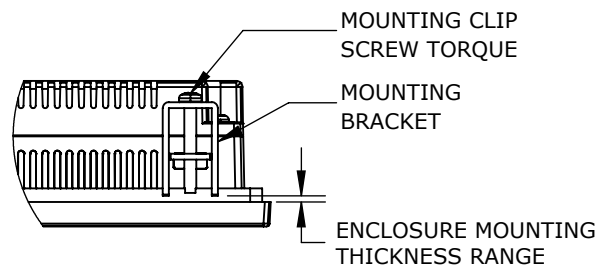

Touch Panel Size	Enclosure Thickness Range	Mounting Clip Screw Torque	Material
<b>4-inch</b>	0.039 - 0.20 inch [1 - 5 mm]	21 - 28 oz-in [0.15 - 0.20 Nm]	Metal
<b>7-inch through 22-inch</b>		135 - 149 oz-in [0.95 - 1.05 Nm]	

**CM5-T12W DIMENSIONS**

All the necessary mounting hardware is provided with the touch panel. Use the four mounting clips and screws to secure the touch panel to the cabinet or enclosure surface.

A template for marking the cutout dimensions on the mounting surface is provided in the box.

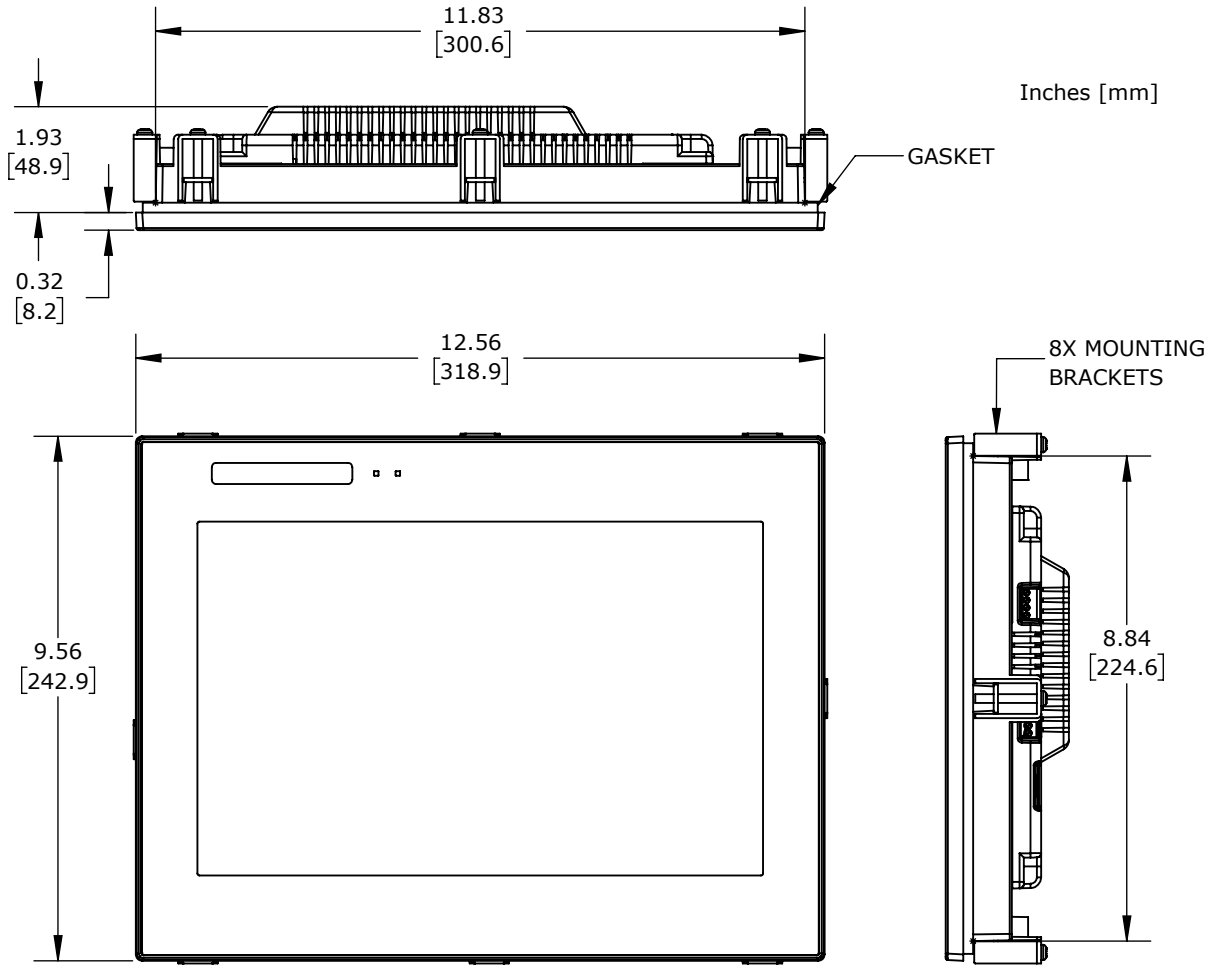

**Enclosure Mounting Thickness Ranges and Mounting Clip Screw Torque**

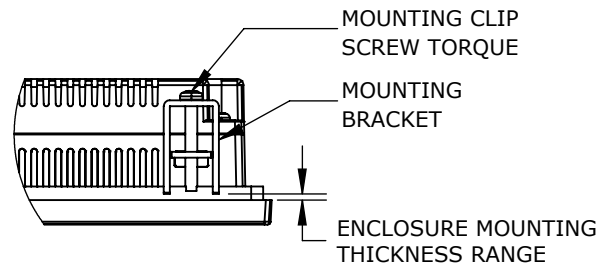

Touch Panel Size	Enclosure Thickness Range	Mounting Clip Screw Torque	Material
4-inch	0.039 - 0.20 inch [1 - 5 mm]	21 - 28 oz-in [0.15 - 0.20 Nm]	Metal
7-inch through 22-inch		135 - 149 oz-in [0.95 - 1.05 Nm]	

**CM5-T15W DIMENSIONS**

All the necessary mounting hardware is provided with the touch panel. Use the four mounting clips and screws to secure the touch panel to the cabinet or enclosure surface.

A template for marking the cutout dimensions on the mounting surface is provided in the box.

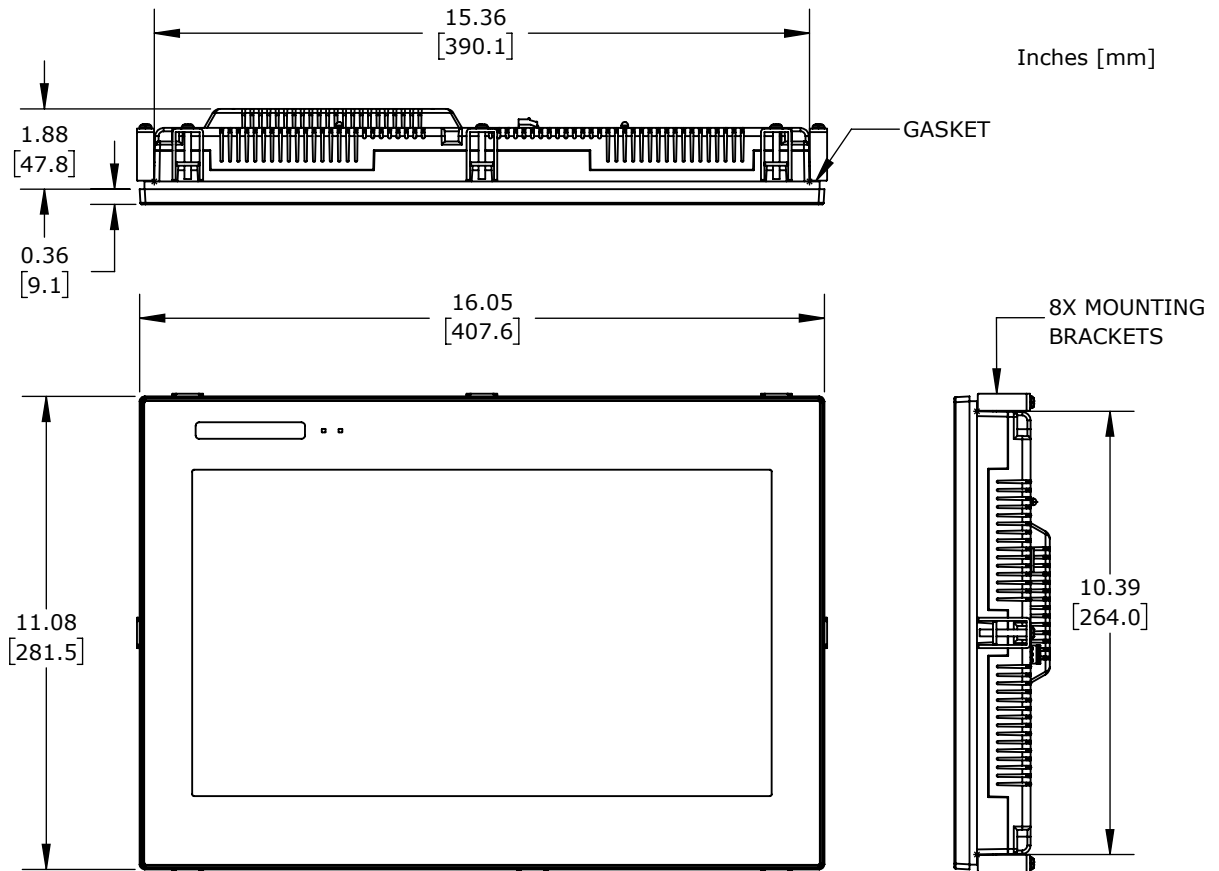

**Enclosure Mounting Thickness Ranges and Mounting Clip Screw Torque**

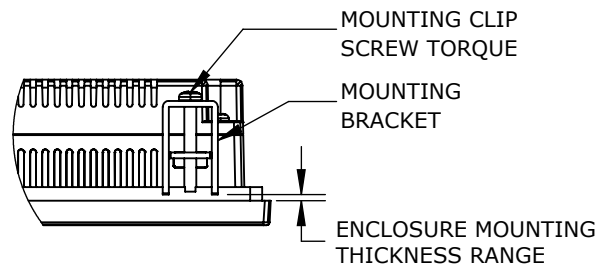

Touch Panel Size	Enclosure Thickness Range	Mounting Clip Screw Torque	Material
<b>4-inch</b>	0.039 - 0.20 inch [1 - 5 mm]	21 - 28 oz-in [0.15 - 0.20 Nm]	Metal
<b>7-inch through 22-inch</b>		135 - 149 oz-in [0.95 - 1.05 Nm]	

**CM5-T22W DIMENSIONS**

All the necessary mounting hardware is provided with the touch panel. Use the four mounting clips and screws to secure the touch panel to the cabinet or enclosure surface.

A template for marking the cutout dimensions on the mounting surface is provided in the box.

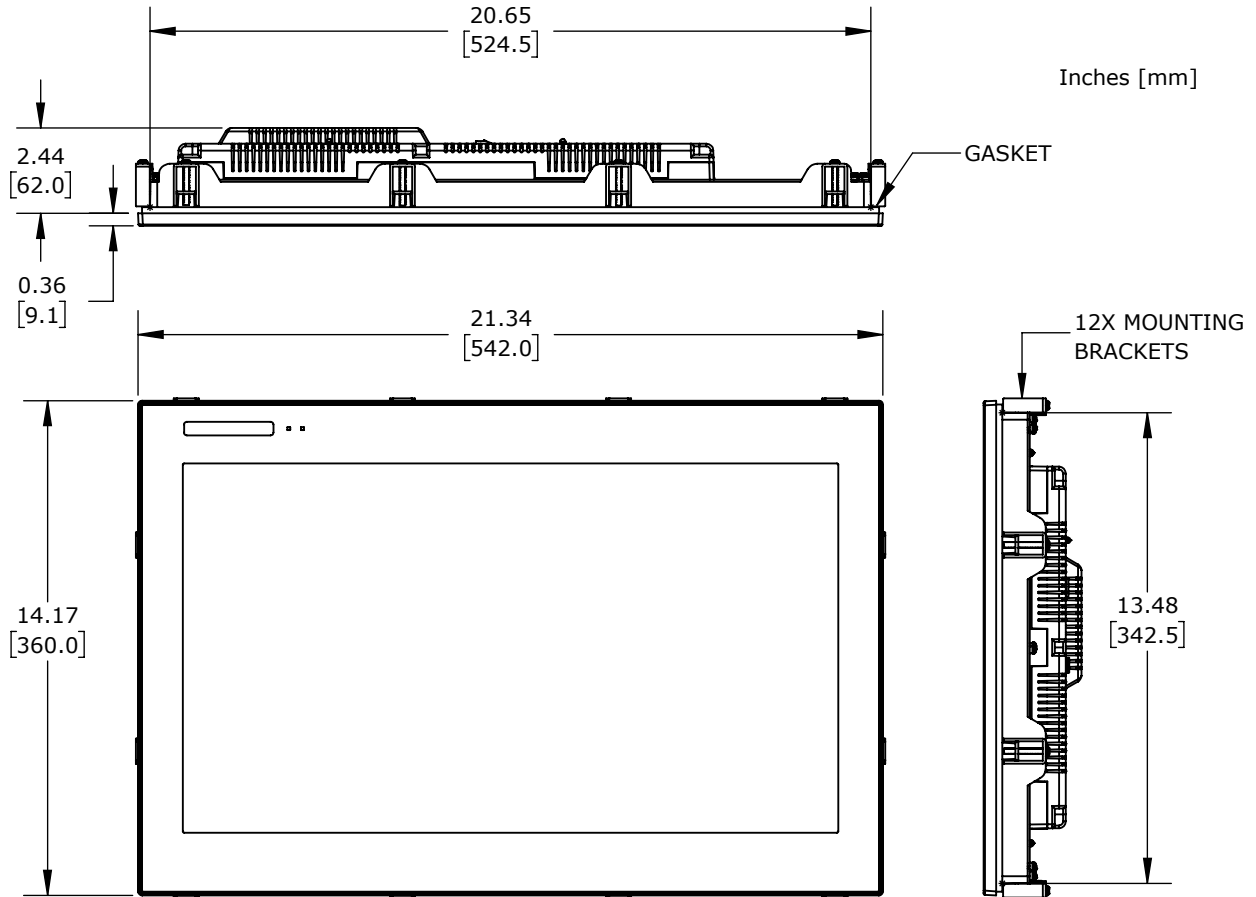

**Enclosure Mounting Thickness Ranges and Mounting Clip Screw Torque**

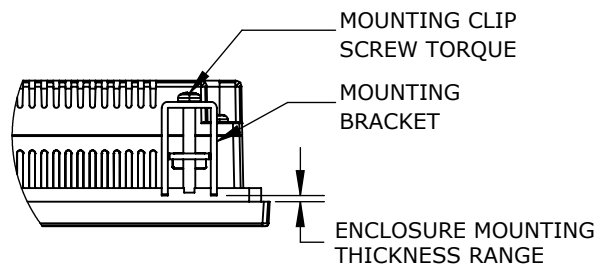

Touch Panel Size	Enclosure Thickness Range	Mounting Clip Screw Torque	Material
4-inch	0.039 - 0.20 inch [1 - 5 mm]	21 - 28 oz-in [0.15 - 0.20 Nm]	Metal
7-inch through 22-inch		135 - 149 oz-in [0.95 - 1.05 Nm]	



**CM5-T10W, CM5-T12W, CM5-T15W AND CM5-T22W PORTS AND MEMORY EXPANSION**

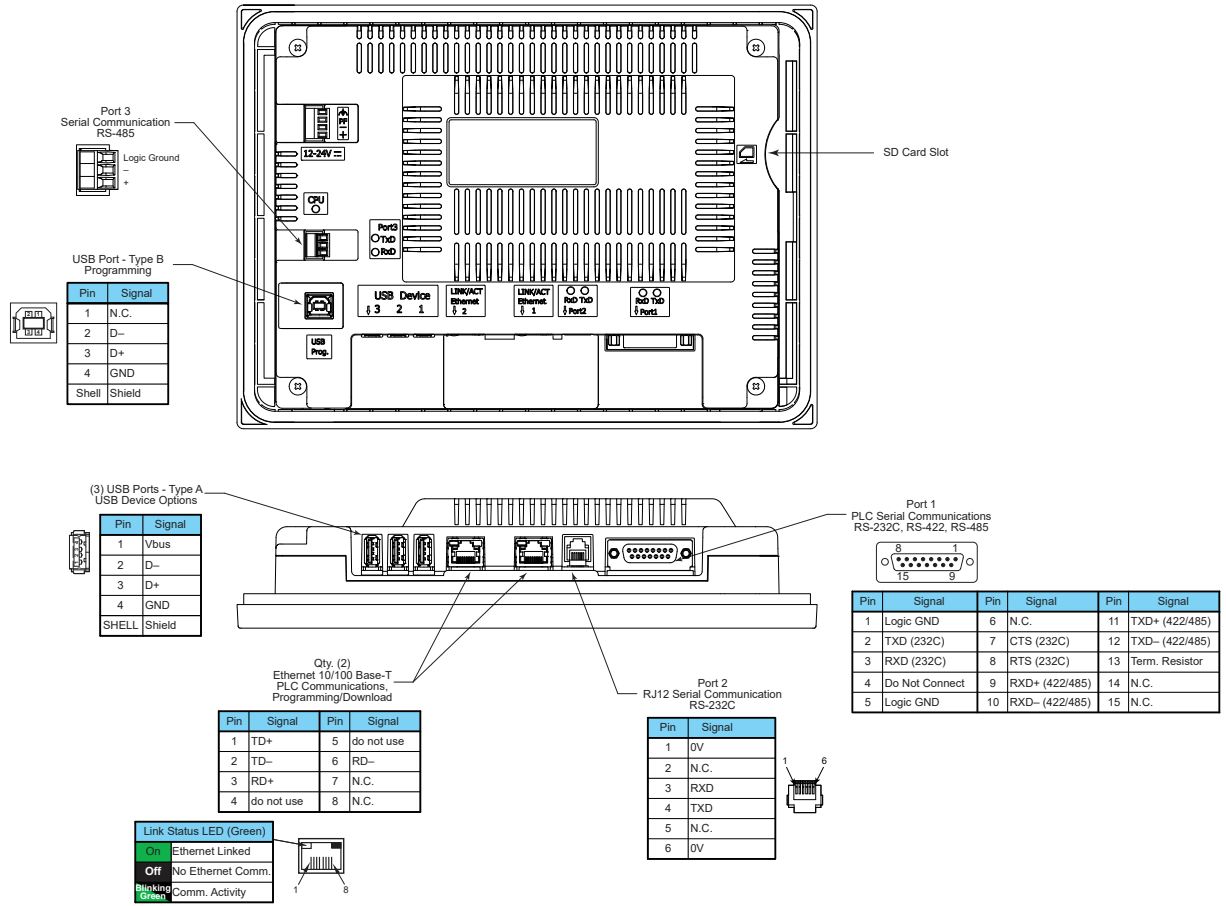

### MOUNTING CLEARANCES

The following drawing shows the mounting clearances for the **C-more** touch panel. There should be a minimum of 4 inches of space between all sides of the panel and the nearest object or obstruction and at least 1.72 inches between the rear of the panel and the nearest object or obstruction.

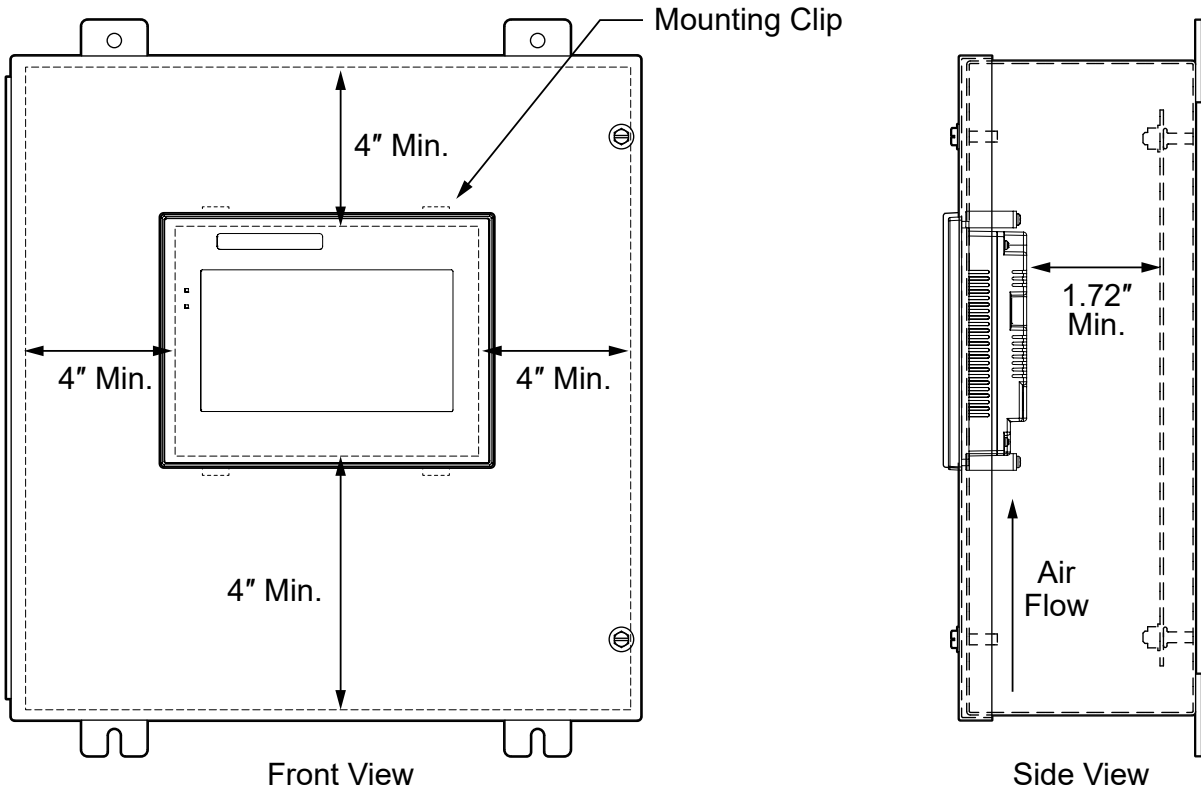

## COMMUNICATION PORTS

### ETHERNET PORT

Either Ethernet port can be used several ways: for programming the panel (downloading a project), for PLC communication, and for the advanced features, such as sending e-mail, web server, FTP access, and allowing users to access and control the panel remotely.

The Ethernet connector is an RJ-45 Module jack.

**See AutomationDirect.com for the latest driver information.**

Network Speed LED (Yellow)	
On	100M
Off	10M

Ethernet 10/100 Base-T  
PLC Communications,  
Programming/Download

Pin	Signal	Pin	Signal
1	TD+	5	do not use
2	TD-	6	RD-
3	RD+	7	N.C.
4	do not use	8	N.C.

Link Status LED (Green)	
On	Ethernet Linked
Off	No Ethernet Comm.
Blinking Green	Comm. Activity

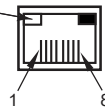

### USB TYPE B PORT

Program **C-more** via the USB programming port. It's fast and easy, with no baud rate settings, parity, or stop bits to worry about. We stock standard USB cables for your convenience, such as part no. USB-CBL-AB15. The USB type B port can be used to upload or download projects to and from a PC (personal computer).

USB Port - Type B  
Programming

Pin	Signal
1	N.C.
2	D-
3	D+
4	GND
Shell	Shield

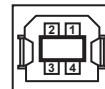

**USB TYPE A PORT**

The USB type A port is a standard feature for all models and can be used to connect various USB 2.0 HID (Human Input Device) devices to the panel, such as:

- Industrial Monitor with a compatible touch screen or Mouse USB pen drives, (ADC p/n USB-FLASH)
- USB keyboards
- USB barcode scanners
- USB card scanners

**C-more** can log data to the USB pen drive as well as restore projects to the panel from the pen drive. You can also back up project files and panel firmware.



**NOTE:** Output current is less than 500mA @ 5VDC.

USB Port - Type A  
USB Device Options

Pin	Signal
1	Vbus
2	D-
3	D+
4	GND
SHELL	Shield



**SERIAL COMMUNICATION PORTS**

**PORT 1**

Connect to your serial controller network via Port 1. Port 1 is a 15-pin port that supports RS-232 and RS-422/485.

Port 1  
PLC Serial Communications  
RS-232C / RS-422 / RS-485

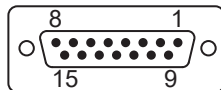

Pin	Signal	Pin	Signal	Pin	Signal
1	Logic GND	6	N.C.	11	TXD+ (422/485)
2	TXD (232C)	7	CTS (232C)	12	TXD- (422/485)
3	RXD (232C)	8	RTS (232C)	13	Term. Resistor
4	Do Not Connect	9	RXD+ (422/485)	14	N.C.
5	Logic GND	10	RXD- (422/485)	15	N.C.

**PORT 2**

Connect to your RS-232C device via Port 2. Port 2 is an RJ12 connection.

Port 2  
RJ12 Serial Communication  
RS-232C

Pin	Signal
1	0V
2	N.C.
3	RXD
4	TXD
5	N.C.
6	0V

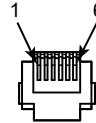

**PORT 3**

Connect your RS-485 network via Port 3. Port 3 is provided with a 3-wire removable terminal block.



**NOTE:** CM5-T4W and CM5-T7W do not include Port 3 but ADC p/n [USB-485M](#) can be used in the USB port for RS485 connections.

Port 2  
Serial Communication  
RS-485

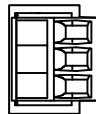

Logic Ground  
-  
+

**USER DEFINED LED**

The user defined LED on the panel front bezel can be controlled from the project to illuminate red, green or orange. It can also be configured to blink these colors. Refer to the online help file provided with the programming software for details.

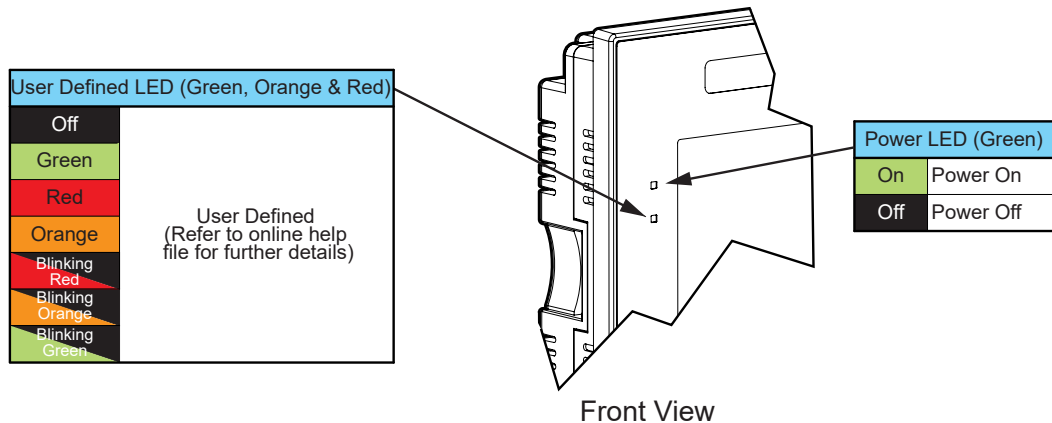

**NOTE:** CM5-T4W doesn't have a User Defined LED or Power LED.

## HANDLING EXTERNAL MEMORY DEVICES

### WRITING TO EXTERNAL MEMORY DEVICES

Different types of numeric and text data from the **C-more** touch panel can be stored on an SD card or a USB memory device. Numeric data from Line Trend Graph and PID Faceplate Trend Graph objects may be stored. Text data from Lookup Text and Multi-state Text Indicator objects can also be stored.

Up to 16 Line Trend or PID Trend objects may be configured in the **C-more** programming software to log data. Along with the 16 object limit, available storage on the external memory device is subject to the memory capacity of the SD card or USB memory device. One log file is created in a 24 hour period for each object. Additionally logging data is initially stored in the buffer in the panel SRAM and data is written to the external memory device:

- when 2kB of data is cached,
- when 20 records have been stored,
- periodically, once every 1 minute,
- when one of the "SYS Copy LogTo %device%" or "SYS %device% Eject" tags is turned on.
- when there is an email or FTP action
- when the System Screen is called
- when the panel date is changed

### MEMORY DEVICE FORMATTING

Memory Devices should be formatted according to the following guidelines to insure best performance and integrity of logged data.

Item		Capacity	Supported Resolution	Supported
<b>USB Memory Device</b>		up to 2GB	FAT	Yes
		4GB to 32GB	FAT 32	Yes
		64GB or larger	exFAT	Yes
<b>SD Card</b>	<b>Type</b>			
	<b>SD</b>	up to 2GB	FAT	Yes
	<b>SDHC</b>	4GB to 32GB	FAT 32	Yes
	<b>SDXC</b>	32GB or larger	exFAT	4" - 7" - No 10" - 22" - Yes

SD cards must be formatted using the SD formatter provided by the SD Association at [www.sdcard.org](http://www.sdcard.org) using the standard allocation unit size for best performance.

### MINIMIZING DATA ERRORS

To minimize data errors when logging data to external memory, consider the following:

- Do not turn off power to the **C-more** touch panel while the external memory device is being accessed.
- Do not remove any external memory device with the device is being accessed by the **C-more** panel.

The following internal tags should be used to monitor, access and safely remove external memory devices:

SYS SD1 WriteStatus  
SYS USB1 WriteStatus  
SYS USB2 WriteStatus  
SYS USB3 WriteStatus  
SYS Copy LogToSD1  
SYS Copy LogToUSB1  
SYS Copy LogToUSB2  
SYS Copy LogToUSB3  
SYS SD1 Eject  
SYS USB1 Eject  
SYS USB2 Eject  
SYS USB3 Eject  
SYS SD1 ReadyToUse  
SYS USB1 ReadyToUse  
SYS USB2 ReadyToUse  
SYS USB3 ReadyToUse

- Be sure to backup the memory device at regular intervals.
- If you suspect the memory device is bad, you may want to use a PC to re-format the device, or use a known good memory device.
- The number of times the memory device can be written to is limited. Consequently, logging frequently will may shorten the service life of the memory device. Using slower sample rates will increase the life of the device.

### MONITORING AVAILABLE MEMORY

Each external memory device can be monitored and events can be configured to alert the user when available memory is approaching the maximum capacity of the external memory device. The following internal tags allow external memory devices data to be monitored:

SYS SD1 TotalMemory  
SYS SD1 FreeMemory  
SYS SD1 UsedMemory  
SYS USB1 TotalMemory  
SYS USB1 FreeMemory  
SYS USB1 UsedMemory  
SYS USB2 TotalMemory  
SYS USB2 FreeMemory  
SYS USB2 UsedMemory  
SYS USB3 TotalMemory  
SYS USB3 FreeMemory  
SYS USB3 UsedMemory

Refer to the **C-more** programming software online help files for additional information on system tags and managing data logging devices.

**POWER LOSS RETENTION**

When a power loss is detected, the panel will attempt to complete all data logging operations safely. The power retention while using a DC power is not long enough to complete writes to an SD Card or USB device. An Uninterruptable Power Supply (UPS) should be considered.

Power Loss Detection (at 25°C)	
Power Supply	Detect Loss
DC (Panel Only)	8.3 VDC

**CHEMICAL COMPATIBILITY**

The **C-more** touch panels comprise three different materials that may be exposed to outside elements: a gasket, a screen sheet and a bezel.

- *Gasket material is silicone.*
- *Screen sheets are PET.*
- *Panel bezels are ABS plastic.*