

# PLC COMMUNICATIONS



## CHAPTER

# 6

### In this Chapter...

<b>Introduction</b> .....	6-2
<b>DirectLOGIC PLCs Password Protection</b> .....	6-2
<b>PLC Protocols</b> .....	6-3
<b>PLC Communication Cables &amp; Wiring Diagrams</b> .....	6-5
Cables from AutomationDirect .....	6-6
AutomationDirect PLCs RS-232C Serial Cables Wiring Diagrams .....	6-7
EA-2CBL .....	6-7
EA-2CBL-1 .....	6-7
EA-3CBL .....	6-7
EA-4CBL-1 .....	6-8
EA-4CBL-2 .....	6-8
AutomationDirect PLCs PLCs RS-422A/RS-485A Cables Wiring Diagrams.....	6-9
DirectLOGIC Universal Isolated Network Adapter, p/n FA-ISOCAN: .....	6-13
DirectLOGIC Universal Converter, p/n F2-UNICON: .....	6-14
RS-422A/RS-485A Multi-Drop Wiring Diagram Examples .....	6-15
Allen-Bradley PLCs RS-232C/RS-485A Serial Cables Wiring Diagrams .....	6-19
EA-MLOGIX-CBL .....	6-19
EA-SLC-232-CBL .....	6-19
EA-PLC5-232-CBL .....	6-19
GE PLCs RS-422/RS-232C Serial Cables Wiring Diagrams.....	6-22
EA-90-30-CBL.....	6-22
Mitsubishi PLCs RS-422/RS-232C Serial Cables Wiring Diagrams .....	6-23
EA-MITSU-CBL .....	6-23
EA-MITSU-CBL-1 .....	6-23
Omron PLCs RS-232C Serial Cables Wiring Diagrams.....	6-25
EA-OMRON-CBL .....	6-25
Modicon PLCs RS-232C Serial Cables Wiring Diagrams.....	6-25
Siemens PLCs RS-485A Serial Cables Wiring Diagrams .....	6-27

## Introduction

The **C-more** family of HMIs are capable of communicating with a wide variety of Programmable Logic Controllers. **C-more** is capable of communicating over RS232, RS422 and RS485 serial networks as well as Ethernet networks. It communicates with all AutomationDirect PLC's utilizing various protocols. **C-more** also communicates with other brands of PLCs by their different protocols. The table on the next page lists all of the various PLCs and protocols that can be configured. The page after the protocol table lists the various serial communication cables that are available to purchase. The rest of this chapter is devoted to showing the pin-to-pin connections of all the available cables plus wiring diagrams that the users can refer to in order to construct their own cables, along with wiring diagrams of cables that are not available for purchase. To simplify RS422/RS485 wiring schemes, we have included wiring diagrams showing connections for available terminal connectors such as our ZIPLink Communication Adapter Module, p/n ZL-CMA15, used for example with our DL-06 and D2-260 PLCs.

If you have difficulty determining whether the particular PLC and/or protocol you are using will work with the **C-more** series of HMIs, please contact our technical support group at 770- 844-4200

## DirectLOGIC PLCs Password Protection



**NOTE:** Many **DirectLogic** PLCs support multi-level password protection of the ladder program. This allows password protection while not locking the communication port to an operator interface. The multilevel password can be invoked by creating a password with an upper case "A" followed by seven numeric characters (e.g. A1234567). Please refer to the specific PLC user manual for further details.

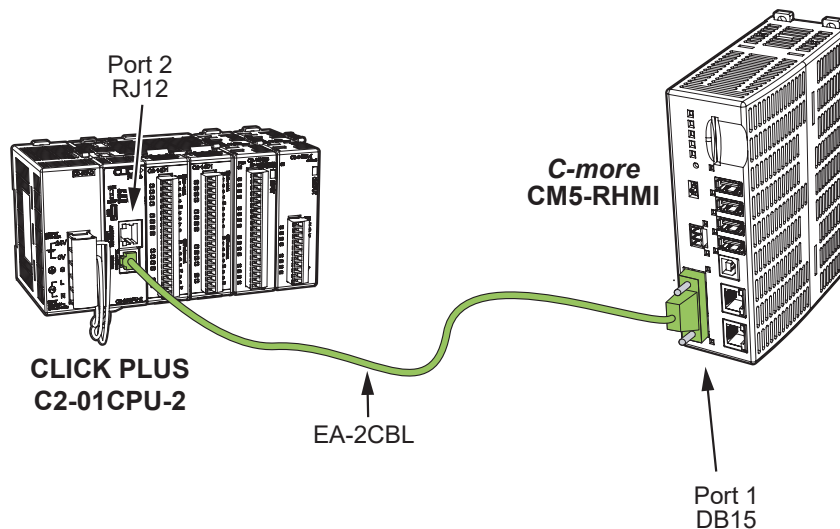

# PLC Protocols

PLC Protocol Table			
Model	Protocols		
<b>AutomationDirect</b>	Productivity Series		
	Productivity Serial		
	Productivity Ethernet		
	Do-more (BRX)	All	Do-more Serial
			Do-more Ethernet
	CLICK	All	CLICK Serial
		C0-1x series	CLICK Ethernet
	CLICK PLUS	C2-01CPU-x, C2-03CPU-x, All with C2-DCM	CLICK Serial
		All	CLICK Ethernet
	DL05/DL06	All	K-Sequence
			<b>DirectNET</b>
		H0-ECOM/H0-ECOM100	Modbus (Koyo addressing)
	DL105	All	DirectLOGIC Ethernet
			K-Sequence
	DL205	D2-230	K-Sequence
		D2-240	K-Sequence
			DirectNET
		D2-250/D2-250-1/D2-260/D2-262	K-Sequence
			<b>DirectNET</b>
			Modbus (Koyo addressing)
		D2-240/D2-250-1/D2-260 Using DCM	<b>DirectNET</b>
		Modbus (Koyo addressing)	
	H2-ECOM/H2-ECOM100	DirectLOGIC Ethernet	
	DL305	D3-330/330P (Requires the use of a Data Communications Unit)	<b>DirectNET</b>
		D3-340	<b>DirectNET</b>
		D3-350	K-Sequence
			<b>DirectNET</b>
			Modbus (Koyo addressing)
	D3-350 DCM	<b>DirectNET</b>	
		Modbus (Koyo addressing)	
DL405	D4-430	K-Sequence	
		<b>DirectNET</b>	
	D4-440	K-Sequence	
		<b>DirectNET</b>	
	D4-450/D4-454	K-Sequence	
		<b>DirectNET</b>	
	Modbus (Koyo addressing)		
All with DCM	<b>DirectNET</b>		
	Modbus (Koyo addressing)		
	H4-ECOM/H4-ECOM100	<b>DirectLOGIC Ethernet</b>	
H2-WinPLC (Think & Do) Live V5.2 or later and Studio any version		Think & Do Modbus RTU (serial port)	
H2-WinPLC (Think & Do) Live V5.5.1 or later and Studio V7.2.1 or later		Think & Do Modbus TCP/IP (Ethernet port)	
GS Drives		GS Drives Serial	
		GS Drives TCP/IP (GS-EDRV)	
SOLO Temperature Controllers (models with serial communications)		SOLO Temperature Controller	

## PLC Protocols (cont'd)

PLC Protocol Table (cont'd)		
Model		Protocols
<b>Allen-Bradley</b>	MicroLogix 1000, 1100, 1200, 1400 and 1500	DF1 Half Duplex; DF1 Full Duplex
	SLC 5-03/04/05	
	ControlLogix™, CompactLogix™, FlexLogix™	
	PLC-5	DF1 Full Duplex
	ControlLogix, CompactLogix, FlexLogix - Tag Based	DF1 Half Duplex; DF1 Full Duplex
	ControlLogix, CompactLogix, FlexLogix - Generic I/O Messaging	EtherNet/IP Server
	ControlLogix, CompactLogix, FlexLogix - Tag Based	EtherNet/IP Client
	MicroLogix 1100, 1400 and SLC 5/05, via native Ethernet port	
	MicroLogix 1000, 1100, 1200, 1400, 1500, SLC 5-03/04/05, all via ENI adapter	
	Micro 800 Series	Modbus RTU
		Modbus TCP
Micro 800 Series - Tag Based	DF1 Full Duplex	
	EtherNet/IP Client	
<b>Modbus RTU</b>	Modbus RTU devices	Modbus RTU
<b>Modbus TCP/IP</b>	Modbus TCP/IP devices	Modbus TCP/IP
<b>GE</b>	90/30, 90/70, Micro 90, VersaMax Micro	SNPX
	90/30, Rx3i	S RTP Ethernet
<b>Mitsubishi</b>	FX Series	FX Direct
	Q02, Q02H, Q06H, Q12H, Q25H	Q CPU
	Q, QnA Serial	QnA Serial
	Q, QnA Ethernet	QnA Ethernet
<b>Modicon</b>	984 CPU, Quantum 113 CPU, AEG Modicon Micro Series 110 CPU: 311-xx, 411-xx, 512-xx, 612-xx	Modbus RTU
	Other devices using Modicon Modbus addressing	Modbus RTU Modbus TCP/IP
<b>Omron</b>	C200 Adapter, C500	Host Link
	CJ1/CS1 Serial	FINS
	CJ1/CS1 Ethernet	
<b>Siemens</b>	S7-200 CPU, RS-485 Serial	PPI
	S7-200 CPU, S7-300 CPU, S7-400, S7-1200, S7-1500 CPU Ethernet	Ethernet ISO over TCP

# PLC Communication Cables & Wiring Diagrams

Cable Description	Cable Part No.
<b>Cables used with 15-pin RS-232/422/485 serial Port1</b>	
AutomationDirect Productivity Series, Do-more, CLICK, <b>Direct</b> LOGIC PLC RJ-12 port, DL05, DL06, DL105, DL205, D3-350, D4-450 & H2-WinPLC (RS-232C) 3m (9.8 ft) cable length	<b>EA-2CBL</b>
<b>Direct</b> LOGIC (VGA Style) 15-pin port, DL06, D2-250 (250-1), D2-260 (RS-232C) 3m (9.8 ft) cable length	<b>EA-2CBL-1</b>
<b>Direct</b> LOGIC PLC RJ-11 port, D3-340 (RS-232C) 3m (9.8 ft) cable length	<b>EA-3CBL</b>
<b>Direct</b> LOGIC DL405 PLC 15-pin D-sub port, DL405 (RS-232C) 3m (9.8 ft) cable length	<b>EA-4CBL-1</b>
<b>Direct</b> LOGIC PLC 25-pin D-sub port, DL405, D3-350, DL305 DCU and all DCM's (RS-232C) 3m (9.8 ft) cable length	<b>EA-4CBL-2</b>
Allen-Bradley MicroLogix 1000, 1100, 1200, 1400 & 1500 (RS-232C) 3m (9.8 ft) cable length	<b>EA-MLOGIX-CBL</b>
Allen-Bradley SLC 5-03/04/05, ControlLogix, CompactLogix, FlexLogix DF1 port (RS-232C)	<b>EA-SLC-232-CBL</b>
Allen-Bradley PLC-5 DF1 port (RS-232C) 3m (9.8 ft) cable length	<b>EA-PLC5-232-CBL</b>
GE 90/30, 90/70, Micro 90, Versamax Micro (Port2) 15-pin D-sub port (RS-422A) 3m (9.8 ft) cable length	<b>EA-90-30-CBL</b>
MITSUBISHI FX Series 25-pin port (RS-422A) 3m (9.8 ft) cable length	<b>EA-MITSU-CBL</b>
MITSUBISHI FX Series 8-pin mini-DIN (RS-422A) 3m (9.8 ft) cable length	<b>EA-MITSU-CBL-1</b>
OMRON Host Link (C200 Adapter, C500) (RS-232C) 3m (9.8 ft) cable length	<b>EA-OMRON-CBL</b>

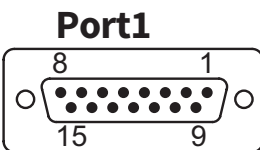

D-Sub 15-pin female  
on front of the CM5-RHMI  
RS-232C, RS-422, RS-485

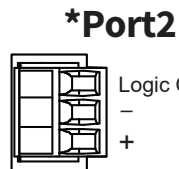

Logic Ground  
-  
+  
RS-485 Serial Communications



**NOTE:** All cables for connections at Port 2 are user constructed. Refer to the specifications of the connected device port to construct the cable properly. The connector for Port 2, HMI-3TB, is included with your C-more panel.

## Cables from AutomationDirect

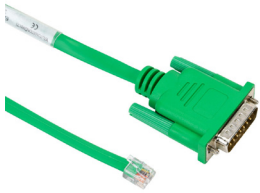

Part No. EA-2CBL



Part No. EA-2CBL-1

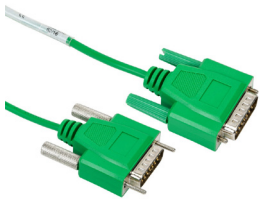

Part No. EA-4CBL-1



Part No. EA-4CBL-2



Part No. EA-3CBL



Part No. EA-MLOGIX-CBL

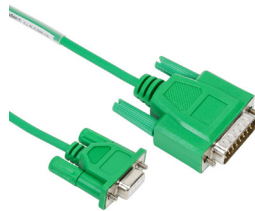

Part No. EA-SLC-232-CBL



Part No. EA-PLC5-232-CBL

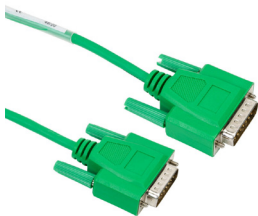

Part No. EA-90-30-CBL



Part No. EA-OMRON-CBL

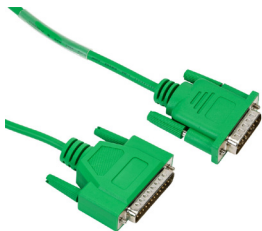

Part No. EA-MITSU-CBL

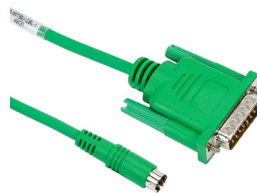

Part No. EA-MITSU-CBL-1

## AutomationDirect PLCs RS-232C Serial Cables Wiring Diagrams

The following series of wiring diagrams show the connectors and wiring details for the communication cables that are used between the **C-more** touch panels and various PLC controllers. Part numbers are included with the pre-made cables that can be purchased from AutomationDirect. The information presented will allow the user to construct their own cables if so desired.

### EA-2CBL

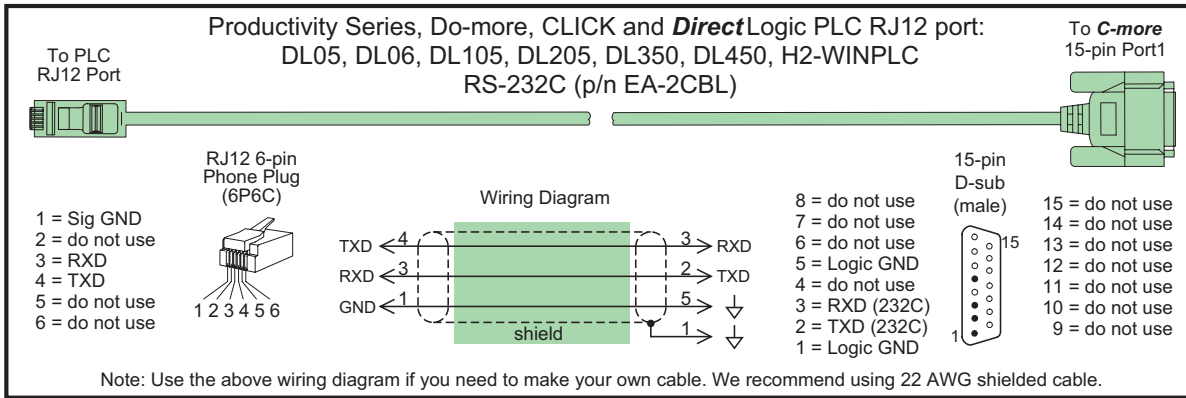

### EA-2CBL-1

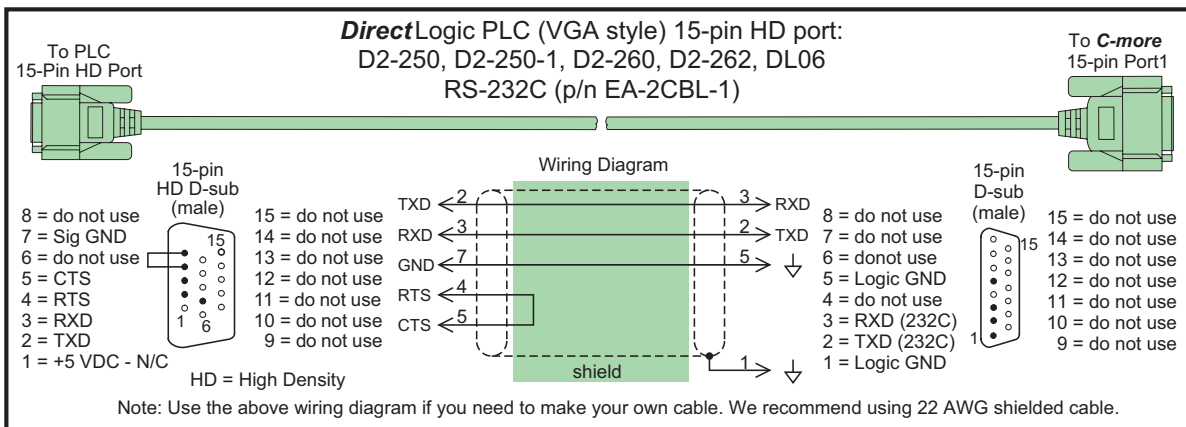

### EA-3CBL

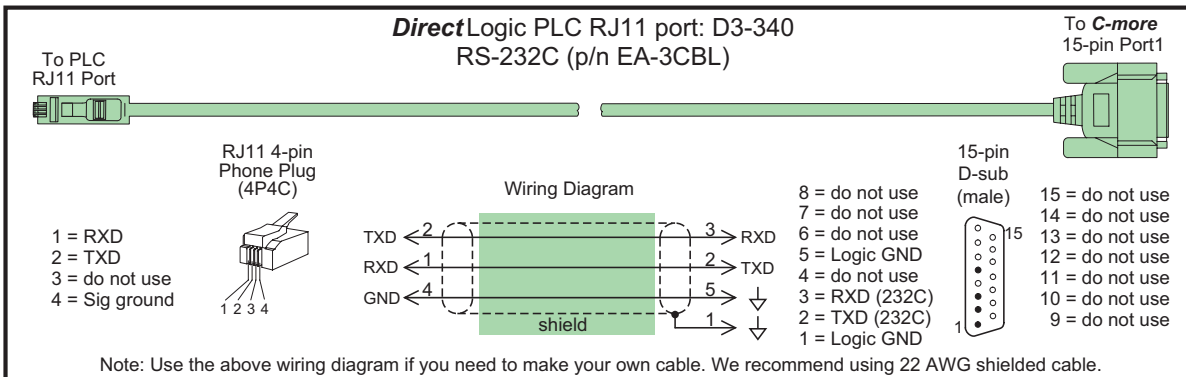

### EA-4CBL-1

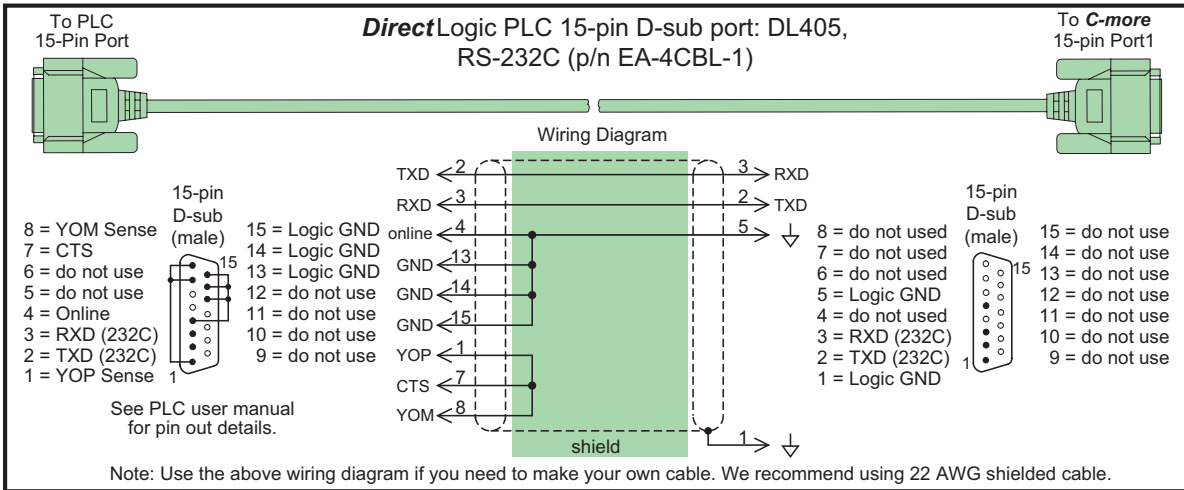

### EA-4CBL-2

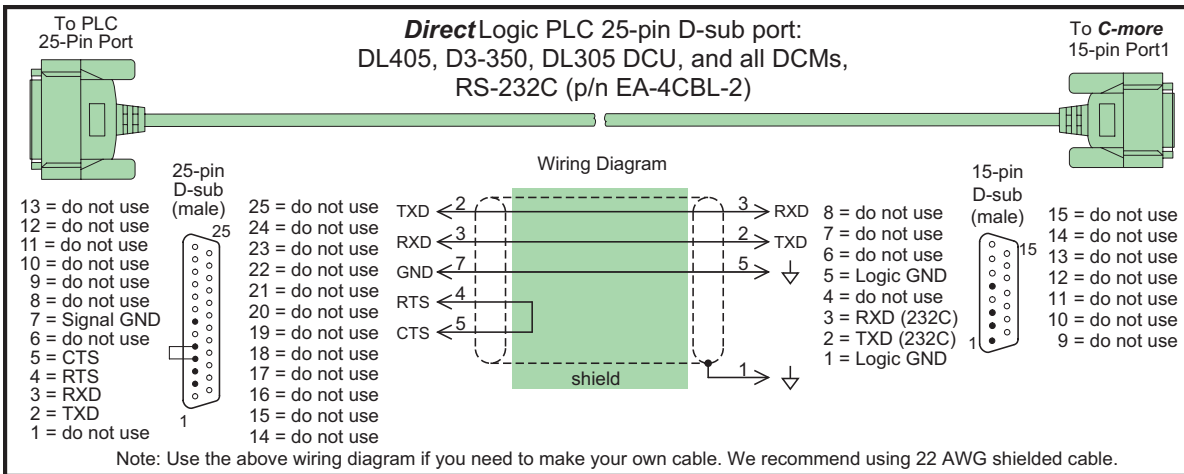



## AutomationDirect PLCs RS-422A/RS-485A Cables Wiring Diagrams

When using the RS-422A/RS-485A capabilities of the **C-more** 15-pin PLC communications Port1, the termination resistor is placed between the RXD- and RXD+ terminals on the PLC side of the connection between the touch panel and PLC. The Termination Resistor value is based on the characteristic impedance of the cable being used. To enable the built-in 120 Ohm Termination Resistor, jumper pin 13 to pin 9 (RXD+) on the **C-more** 15-pin PLC communications Port1.

### User Constructed

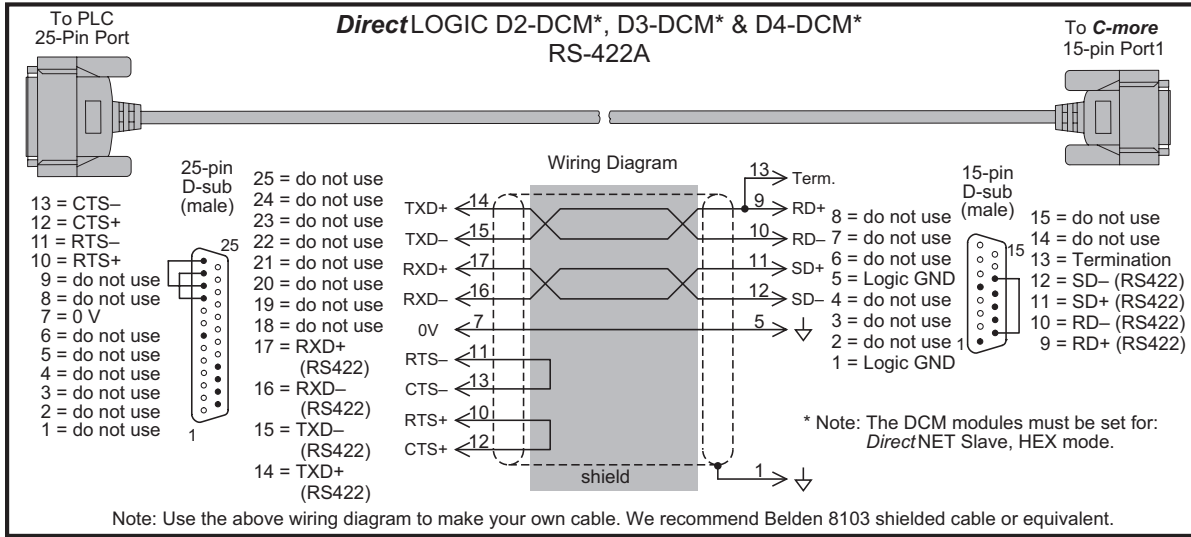

### User Constructed

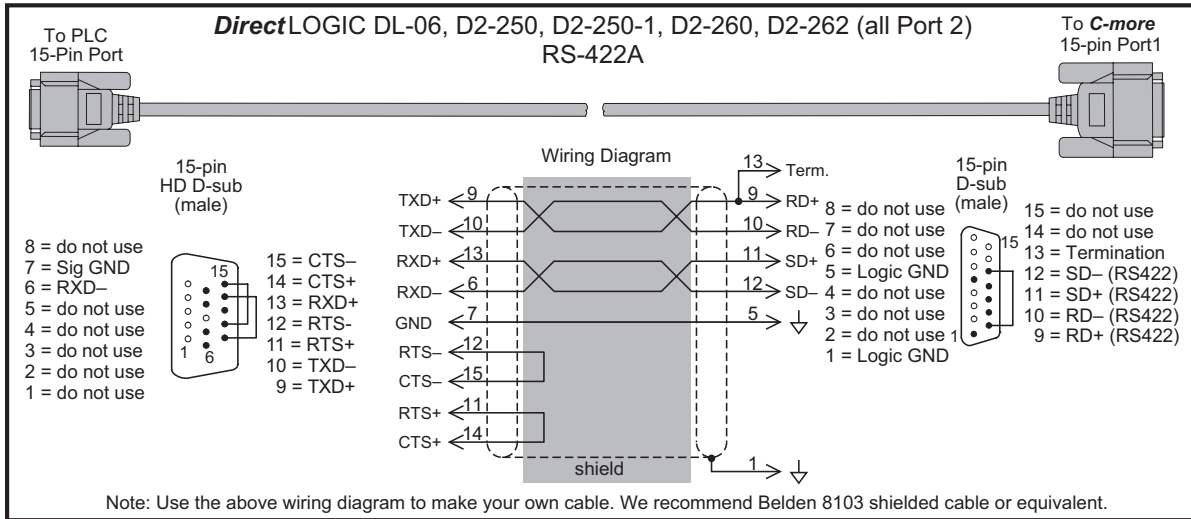

**NOTE:** The RS-422 wiring diagrams shown above are not for multi-drop networks involving connecting more than one PLC to a panel. Refer to the multi-drop wiring diagram examples later in this chapter if more than one PLC will be connected to a panel.

### User Constructed

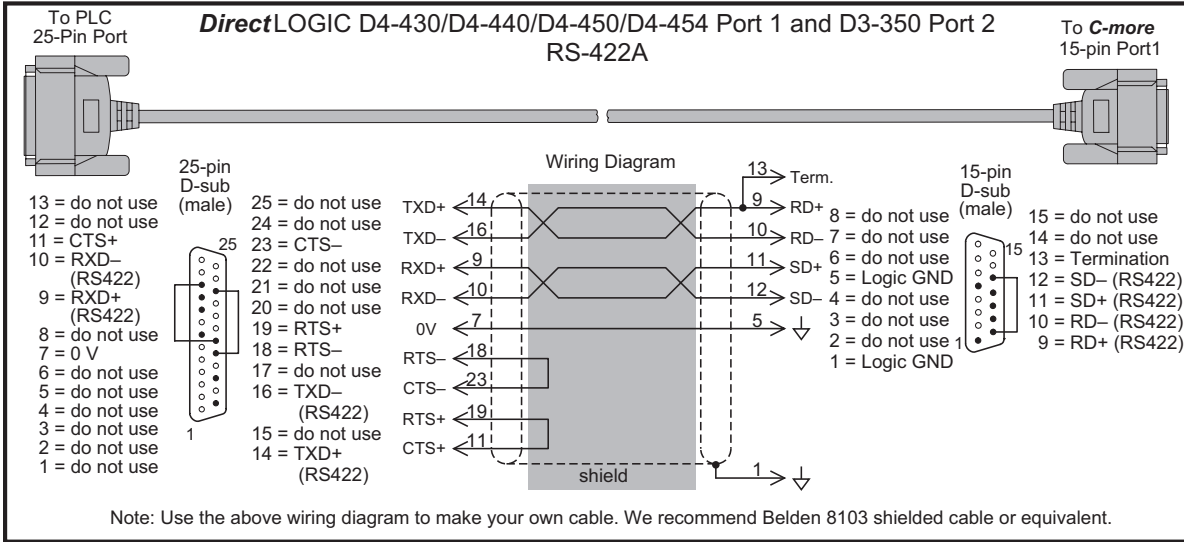

### User Constructed

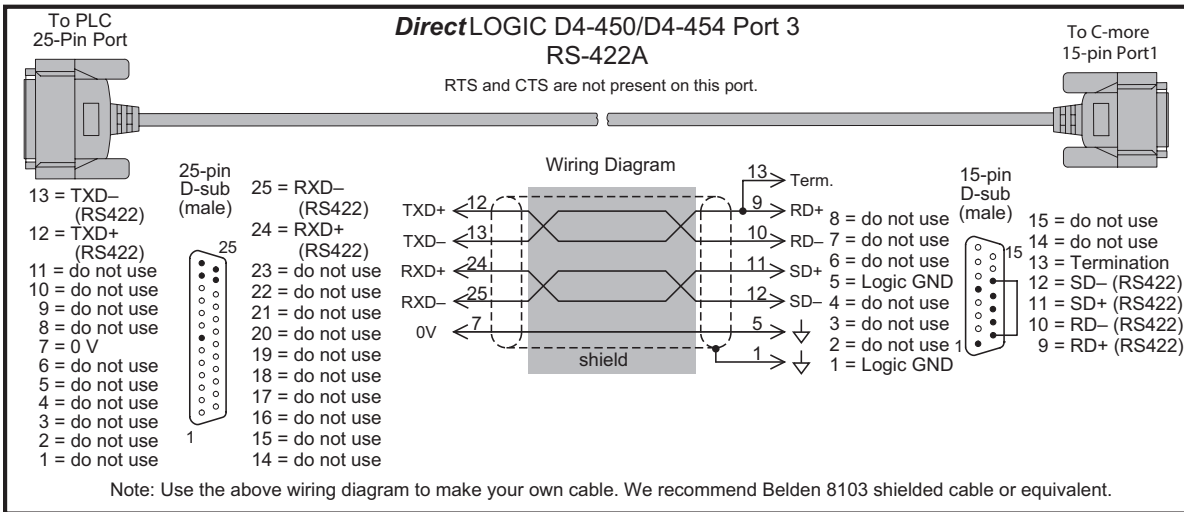

**NOTE:** The RS-422 wiring diagrams shown above are not for multi-drop networks involving connecting more than one PLC to a panel. Refer to the multi-drop wiring diagram examples later in this chapter if more than one PLC will be connected to a panel.

### User Constructed

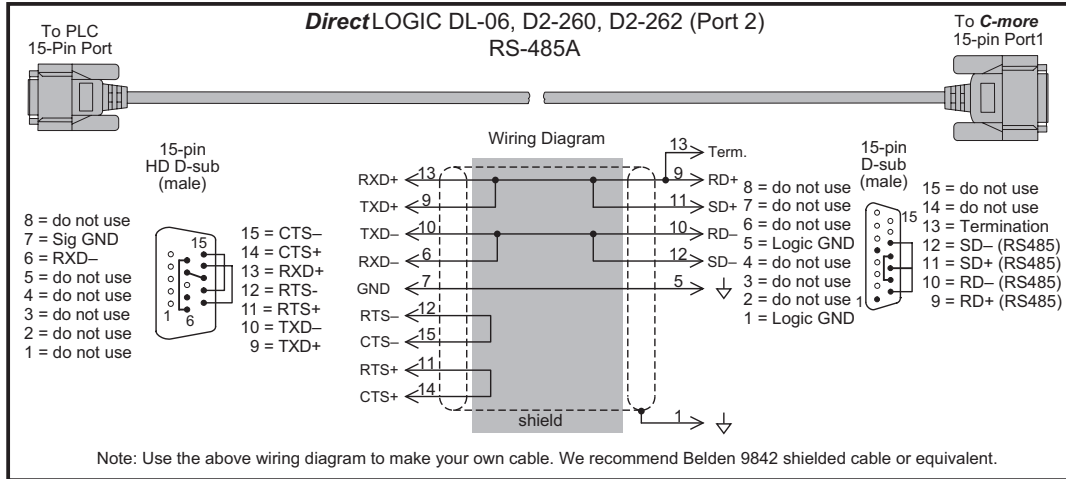

### User Constructed

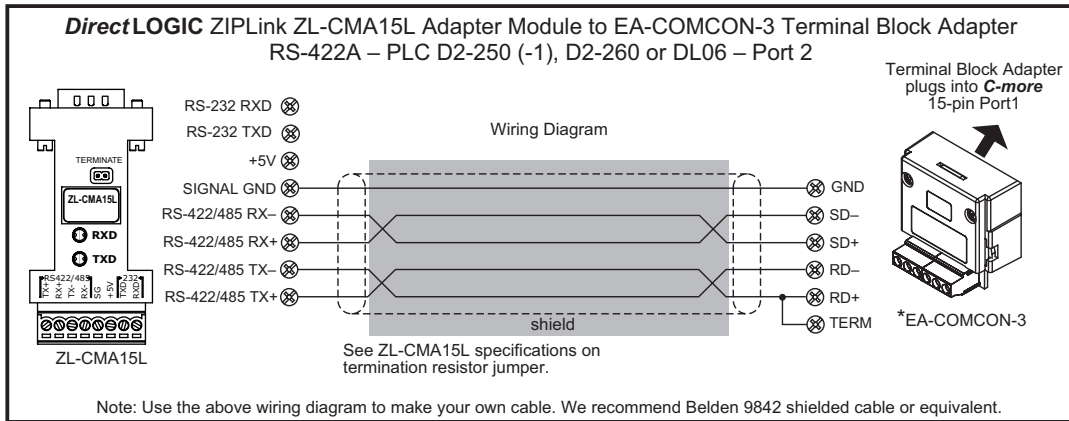

### User Constructed

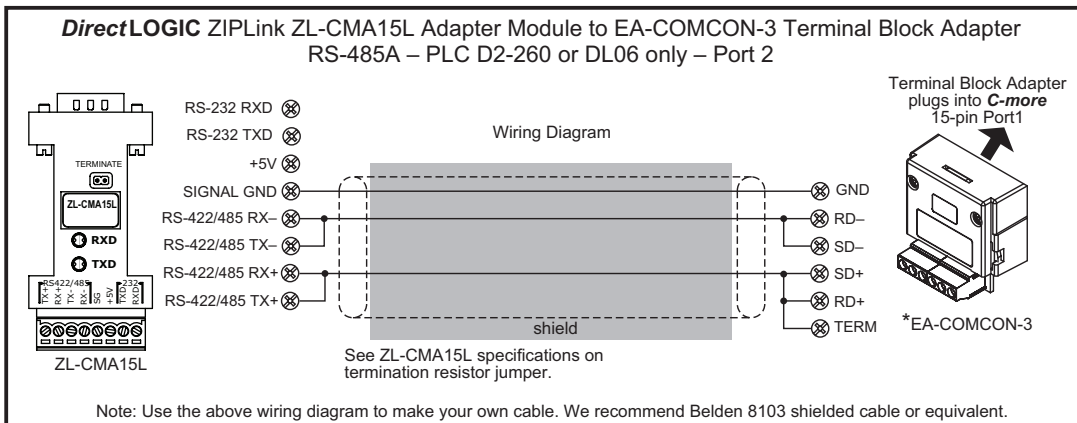

NOTE: EA-COMCON-3 will install only on CM5-T4W. For all other models use EA-COMCON-3A

NOTE: The RS-422 wiring diagrams shown above are not for multi-drop networks involving connecting more than one PLC to a panel. Refer to the multi-drop wiring diagram examples later in this chapter if more than one PLC will be connected to a panel.

### User Constructed

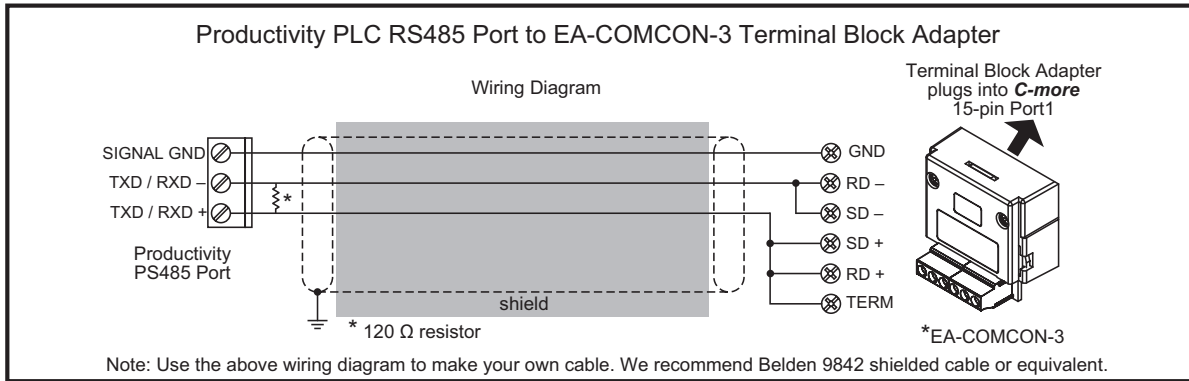

NOTE: EA-COMCON-3 will install only on CM5-T4W. For all other models use EA-COMCON-3A

### User Constructed

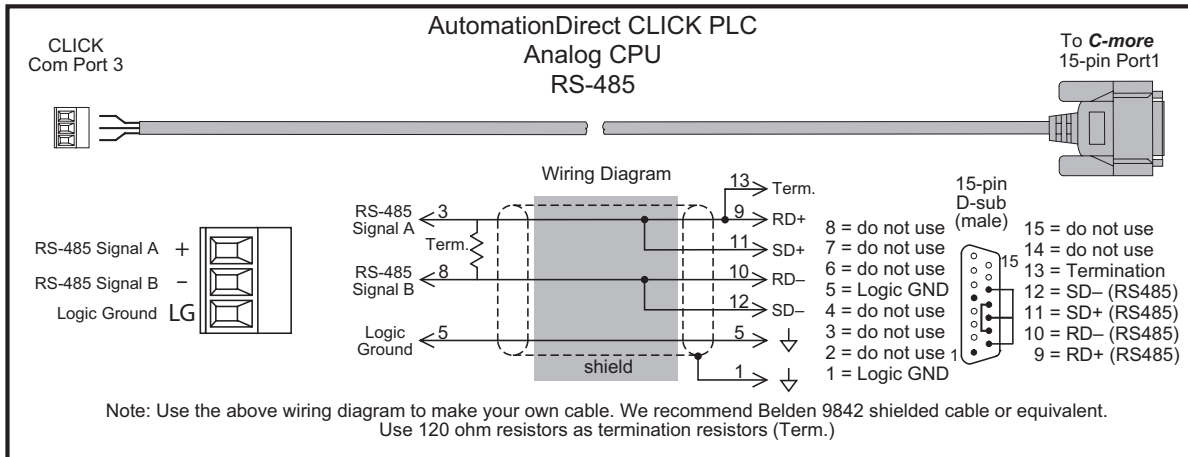

### User Constructed

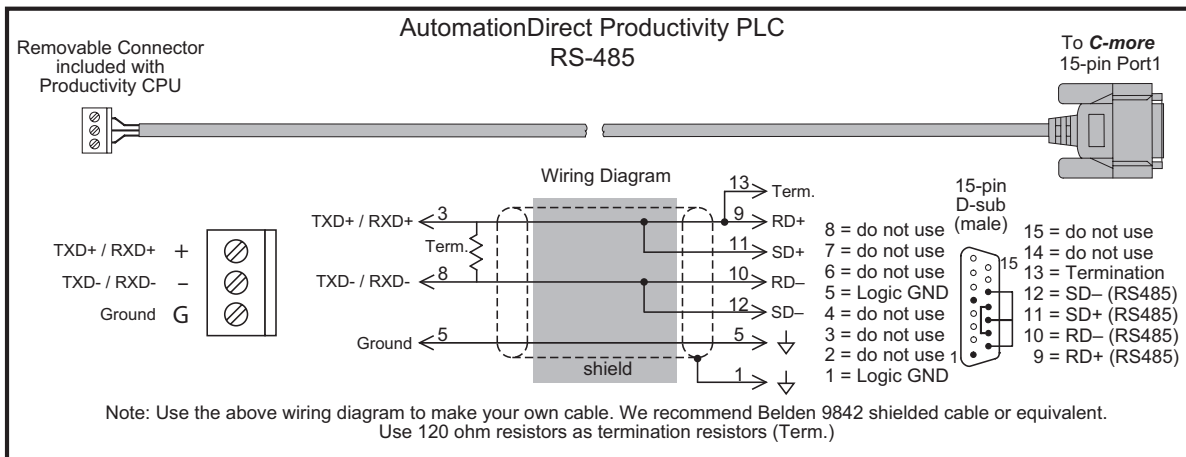

NOTE: The RS-422 wiring diagrams shown above are not for multi-drop networks involving connecting more than one PLC to a panel. Refer to the multi-drop wiring diagram examples later in this chapter if more than one PLC will be connected to a panel.

# DirectLOGIC Universal Isolated Network Adapter, p/n FA-ISOCON:

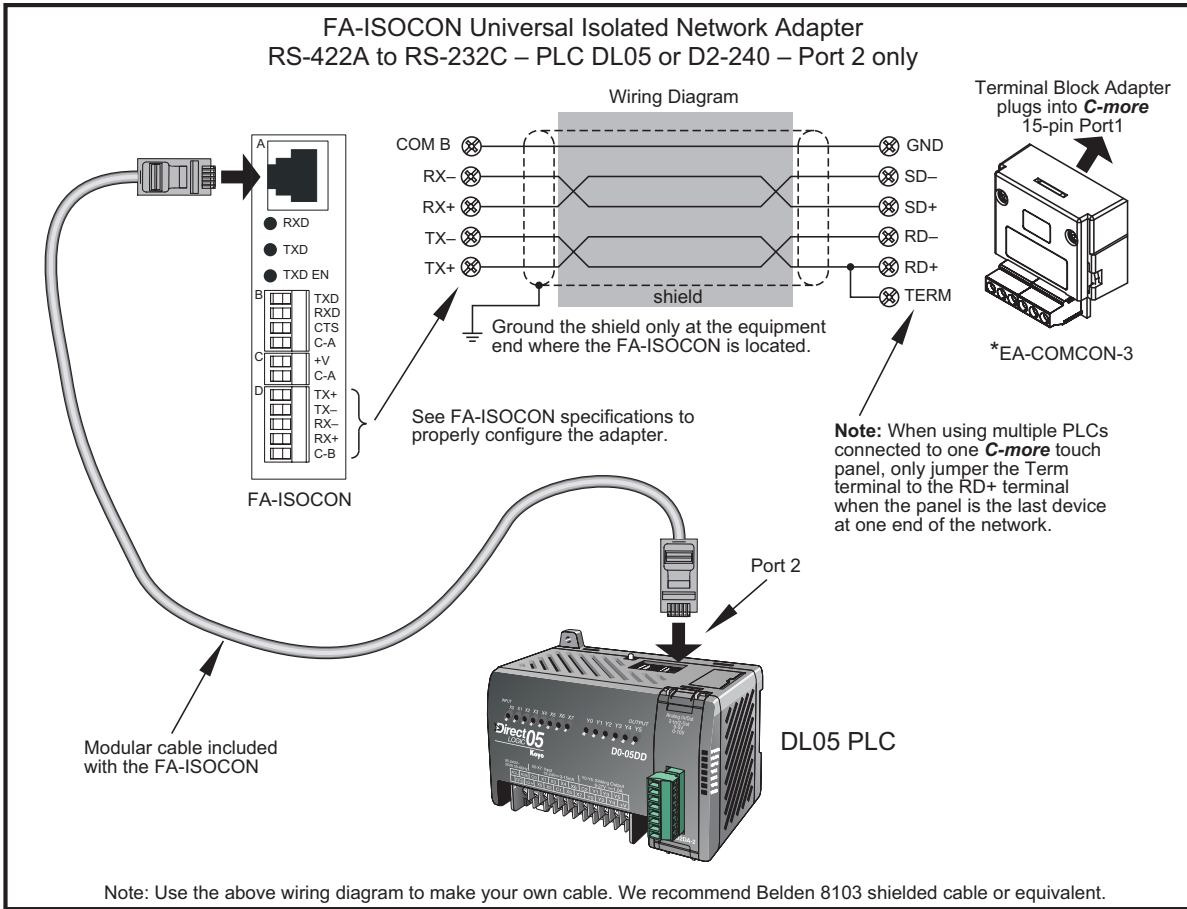

NOTE: EA-COMCON-3 will install only on CM5-T4W. For all other models use EA-COMCON-3A

# DirectLOGIC Universal Converter, p/n F2-UNICON:

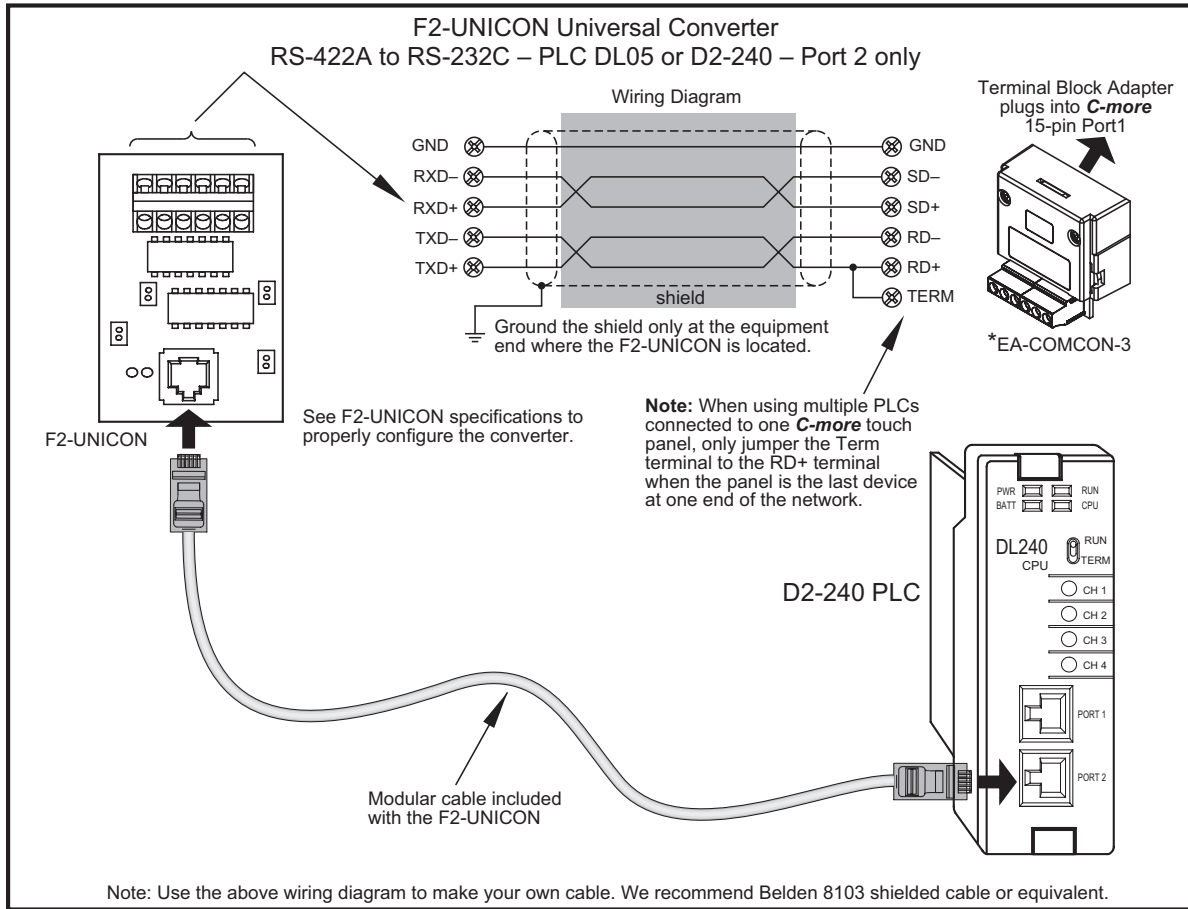

# RS-422A/RS-485A Multi-Drop Wiring Diagram Examples

DL06 and DL205 used for illustration purposes

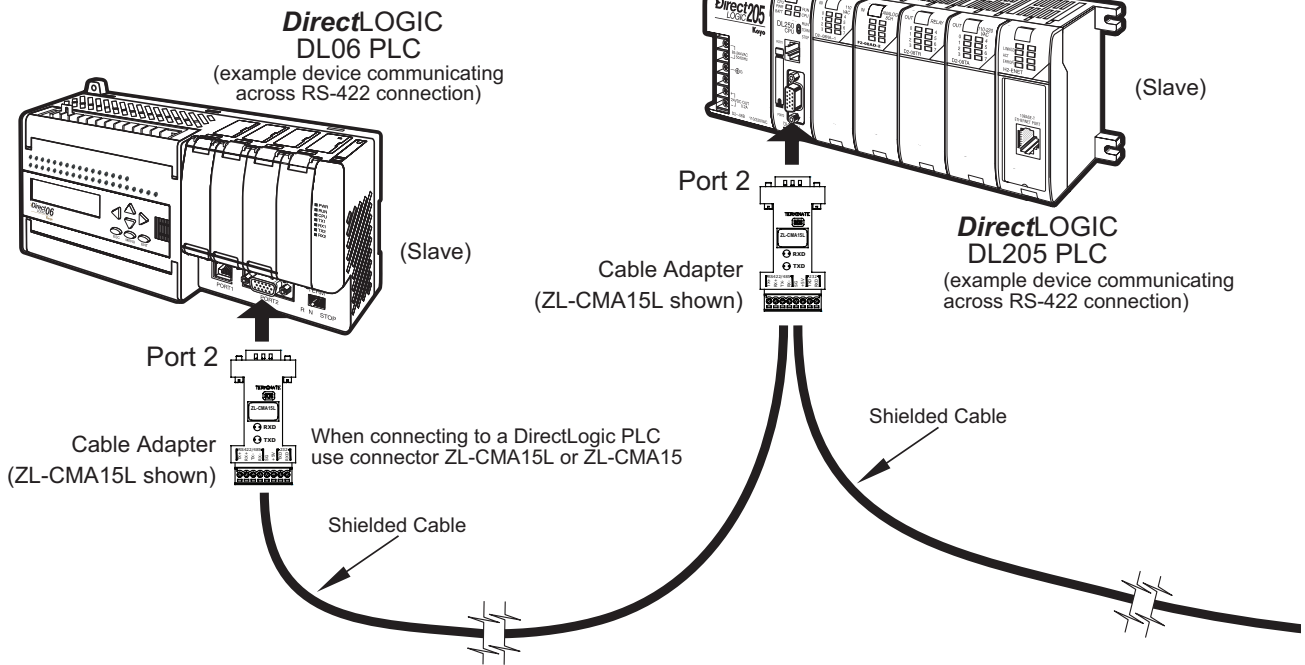

- Notes: 1. We recommend Belden 8103 shielded cable or equivalent.  
2. Wiring Diagram for this example, ZL-CMA15(L)

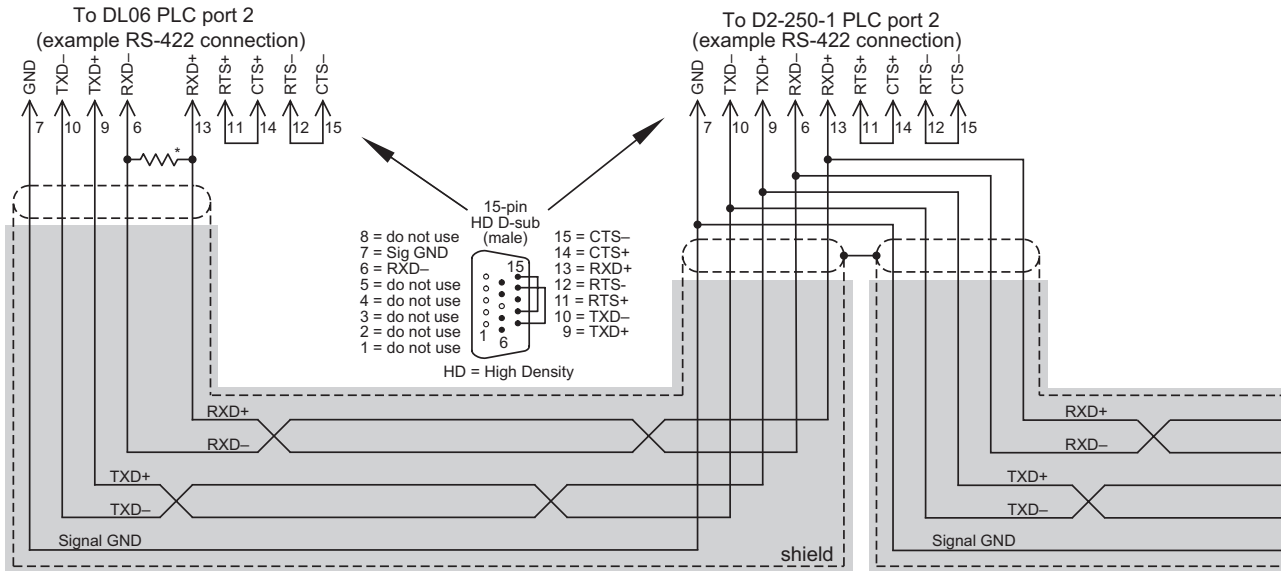

\* Termination resistors required at both ends of the network receive data signals to match the impedance of the cable (between 100 and 500 ohms).

Typical RS-422 Multi-Drop Wiring Diagram  
using DirectLogic pin numbers to illustrate

# RS-422A/RS-485A Multi-Drop Wiring Diagram Examples (cont'd)

DL06 and DL205 used for illustration purposes

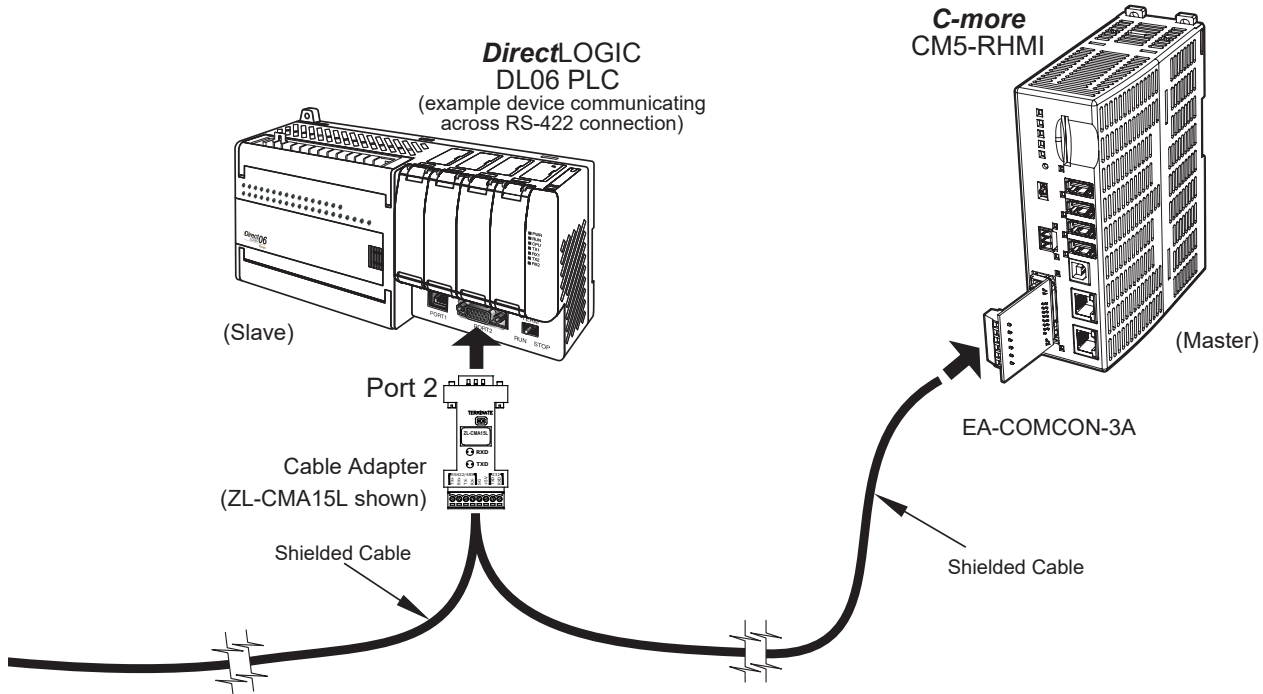

- Notes: 1. We recommend Belden 8103 shielded cable or equivalent.
- 2. Wiring Diagram for this example, ZL-CMA15(L)

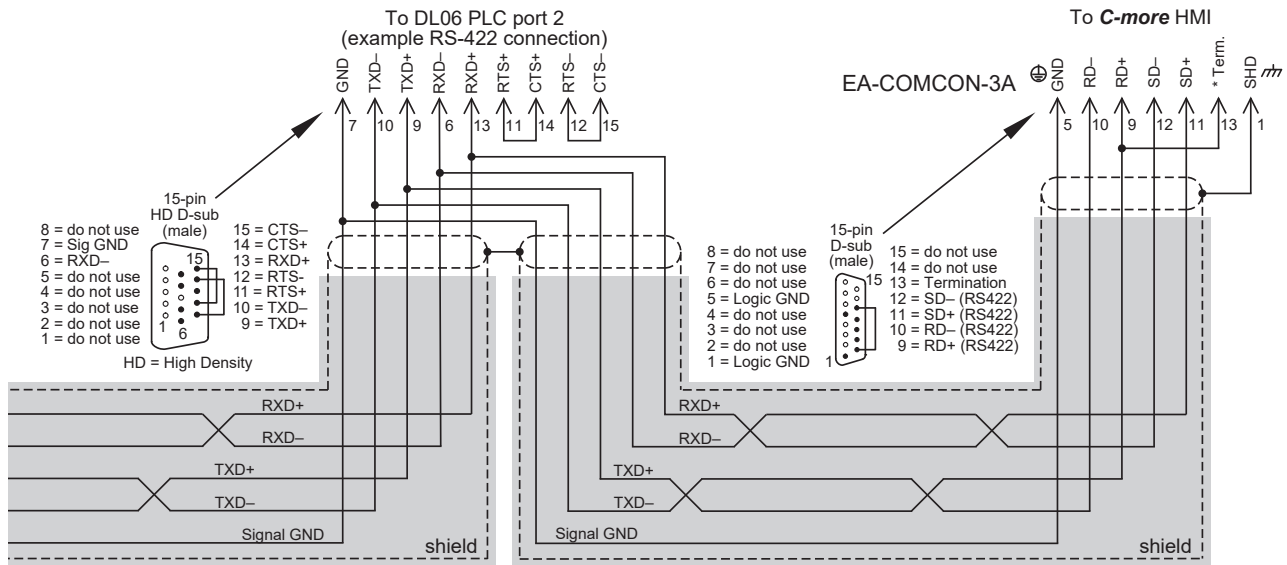

\* Termination resistors required at both ends of the network receive data signals to match the impedance of the cable (between 100 and 500 ohms). Jumper pin 13 to 9 on the C-more HMI 15-pin connector to place the 120q internal resistor into the network. If the cable impedance is different, then use an external resistor matched to the cable impedance.

Typical RS-422 Multi-Drop Wiring Diagram (cont-d)  
using DirectLogic pin numbers to illustrate



# RS-422A/RS-485 Multi-Drop Wiring Diagram Examples (cont'd)

DL06 and DL205 used for illustration purposes

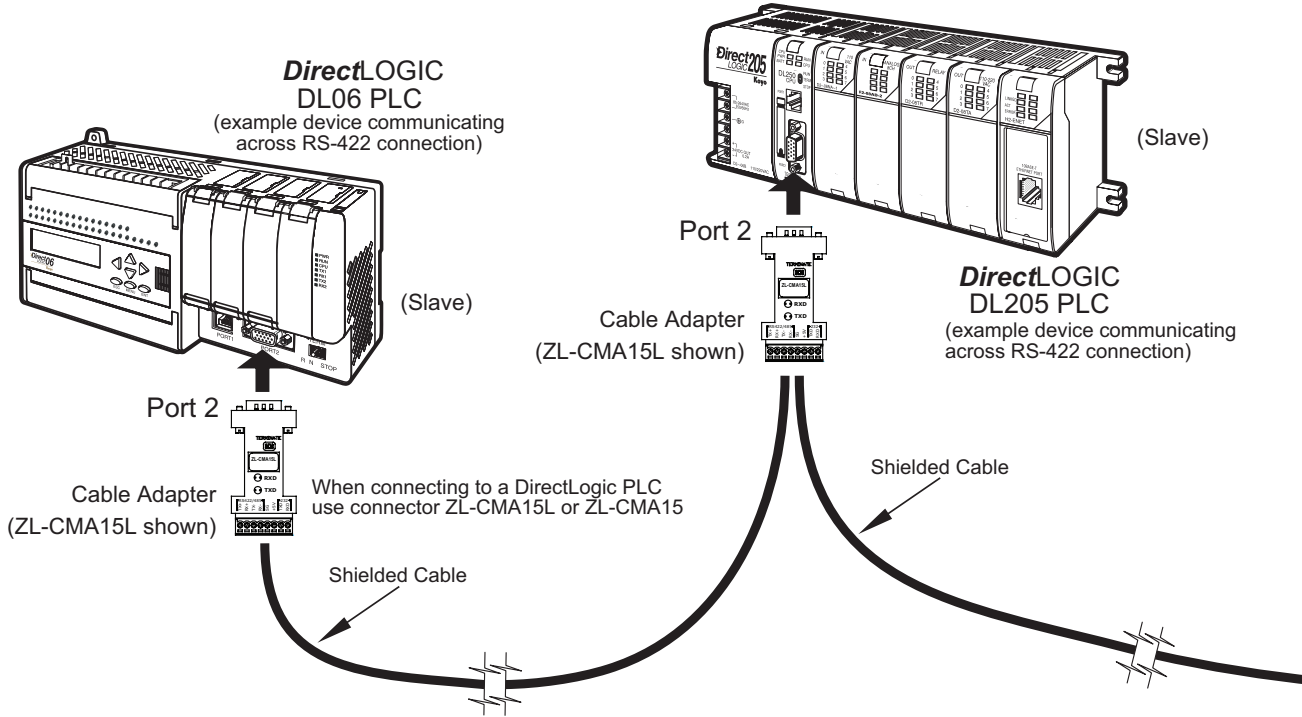

- Notes: 1. We recommend Belden 9842 shielded cable or equivalent.
- 2. Wiring Diagram for this example, ZL-CMA15(L)

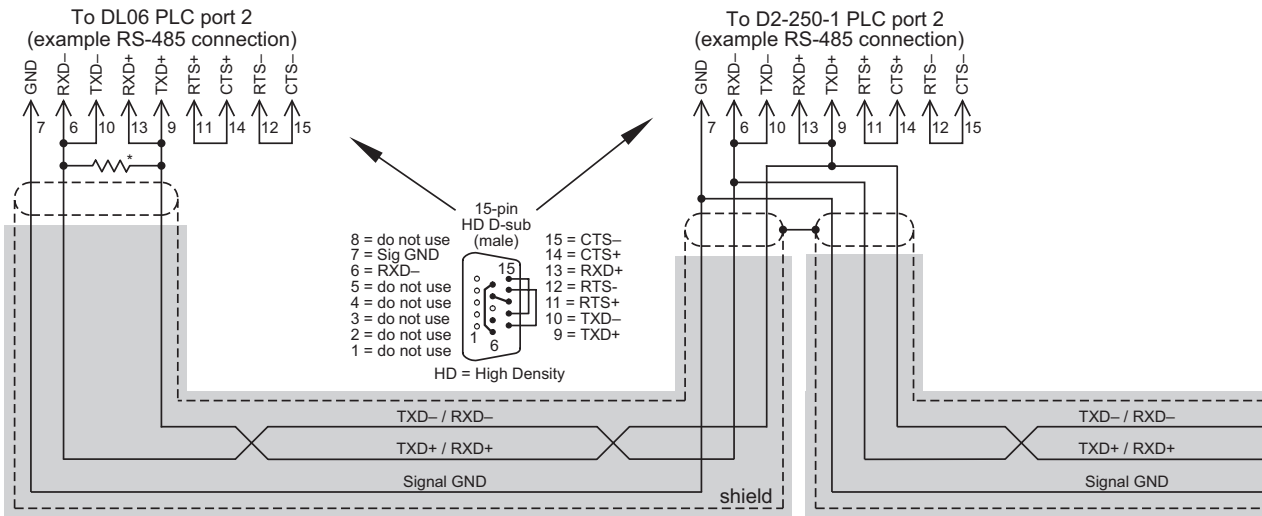

Typical RS-485 Multi-Drop Wiring Diagram  
using DirectLogic pin numbers to illustrate

# RS-422A/RS-485A Multi-Drop Wiring Diagram Examples (cont'd)

DL06 and DL205 used for illustration purposes

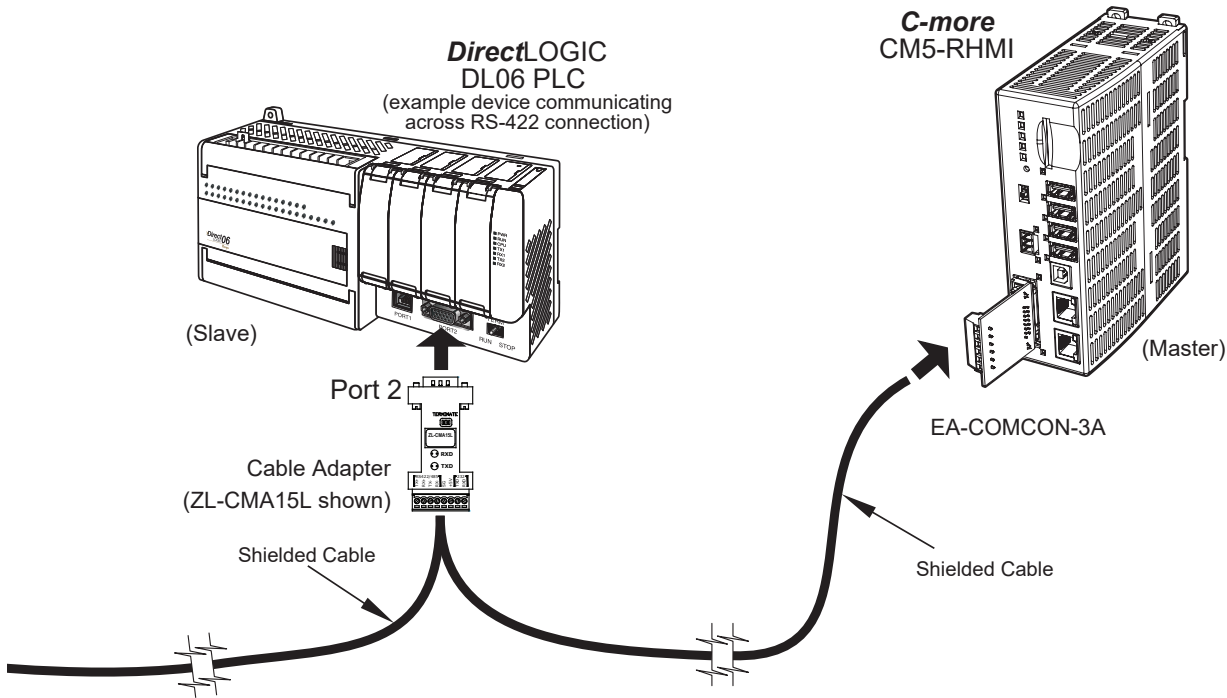

- Notes: 1. We recommend Belden 9842 shielded cable or equivalent.
- 2. Wiring Diagram for this example, ZL-CMA15(L)

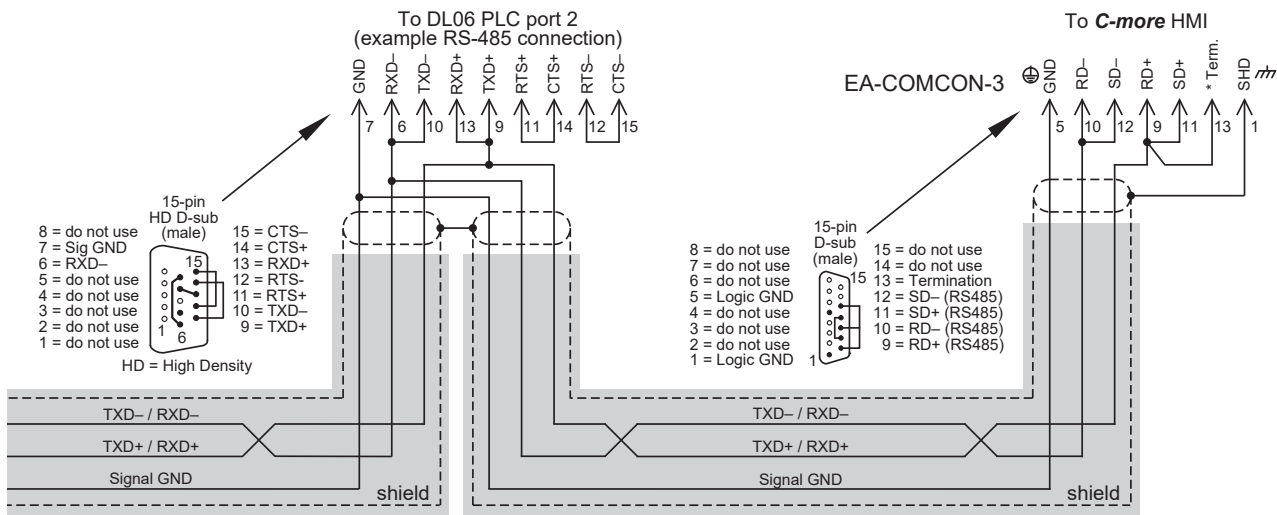

\* Termination resistors required at both ends of the network receive data signals to match the impedance of the cable (between 100 and 500 ohms). Jumper pin 13 to 9 on the **C-more** HMI 15-pin connector to place the 120Ω internal resistor into the network. If the cable impedance is different, then use an external resistor matched to the cable impedance.

## Typical RS-485 Multi-Drop Wiring Diagram (cont-d)

using DirectLogic pin numbers to illustrate

## Allen-Bradley PLCs RS-232C/RS-485A Serial Cables Wiring Diagrams

The following series of wiring diagrams show the connectors and wiring details for the communication cables that are used between the **C-more** touch panels and Allen-Bradley PLC controllers. Part numbers are included with the pre-made cables that can be purchased from AutomationDirect. The information presented will allow the user to construct their own cables if so desired.

### EA-MLOGIX-CBL

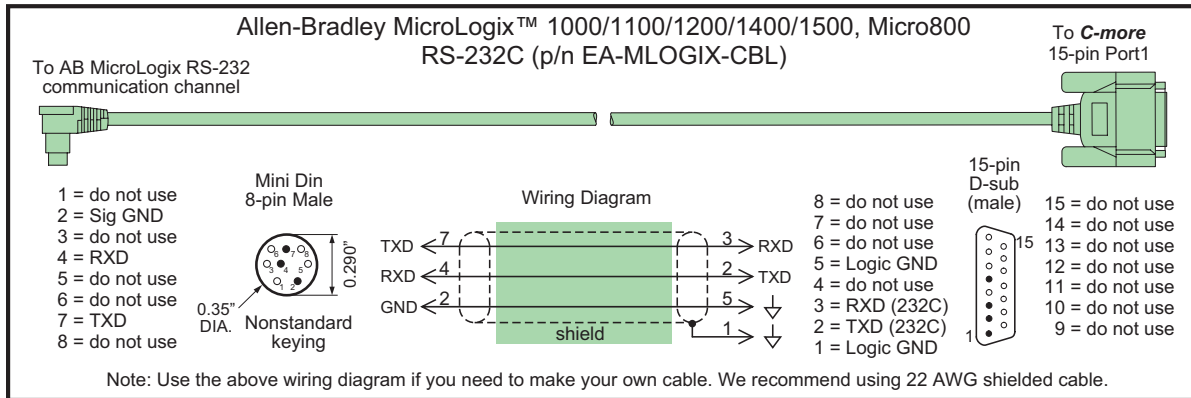

### EA-SLC-232-CBL

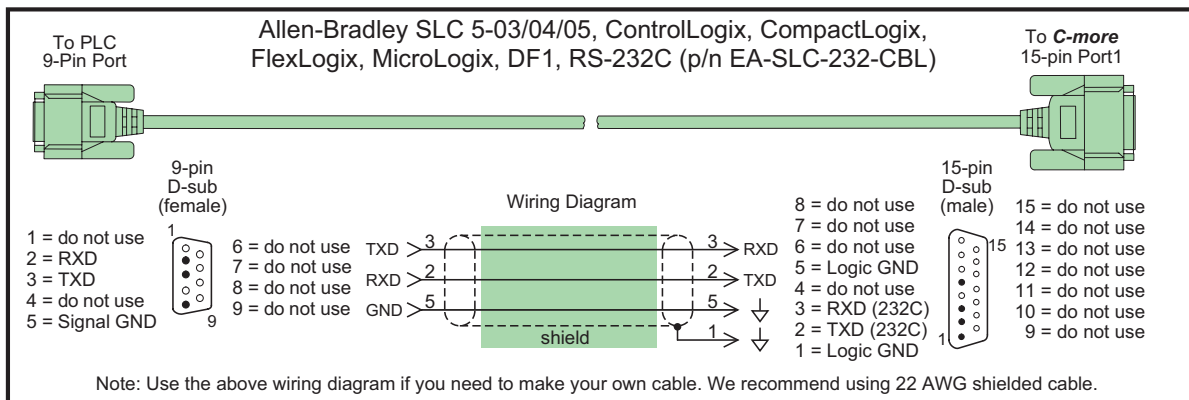

### EA-PLC5-232-CBL

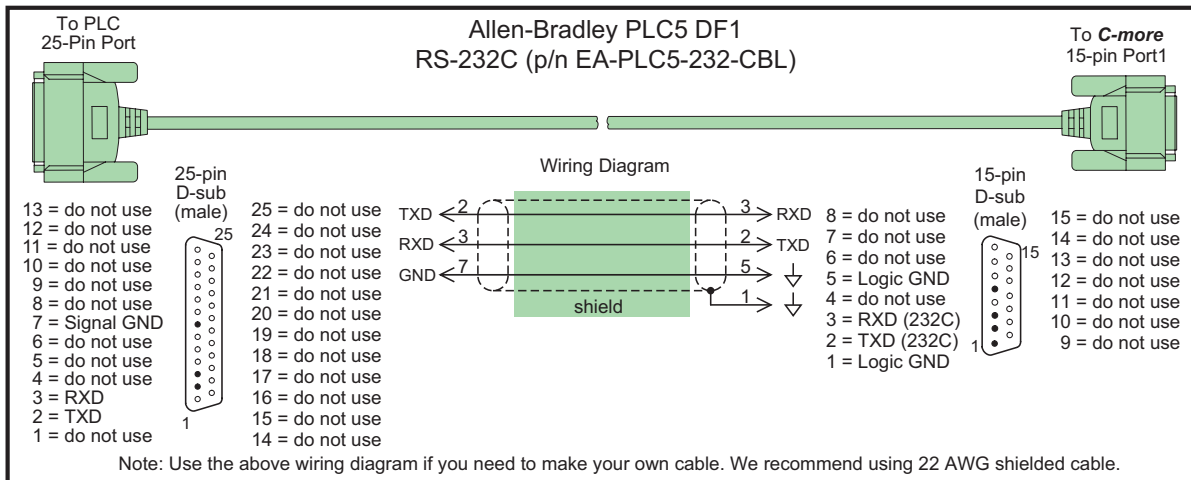

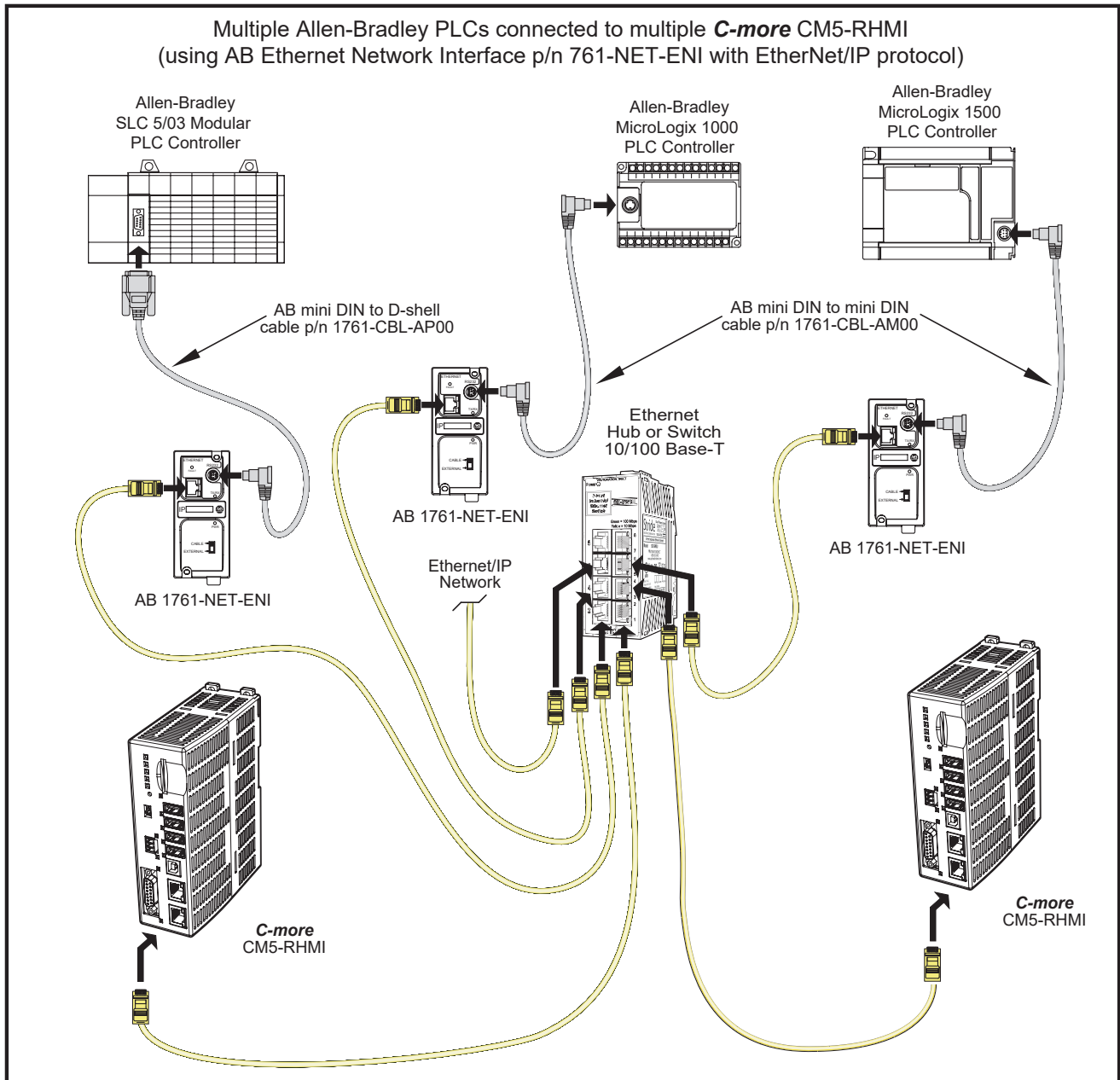

# User Constructed

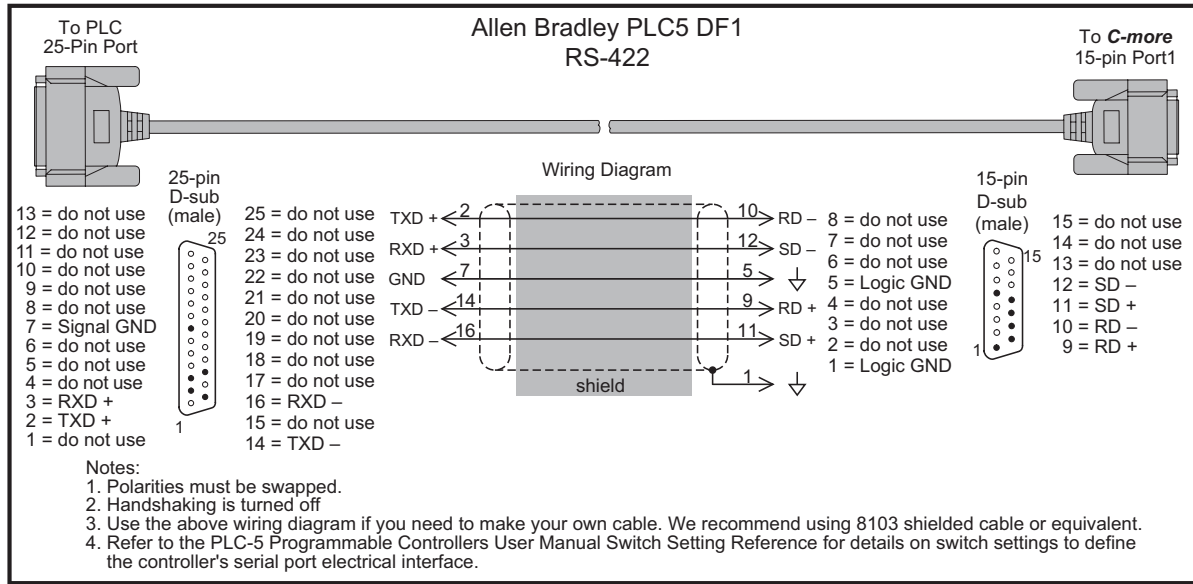

## GE PLCs RS-422/RS-232C Serial Cables Wiring Diagrams

The following series of wiring diagrams show the connectors and wiring details for the communication cables that are used between the **C-more** touch panels and GE PLC controllers. Part numbers are included with the pre-made cables that can be purchased from AutomationDirect. The information presented will allow the user to construct their own cables if so desired.

### EA-90-30-CBL

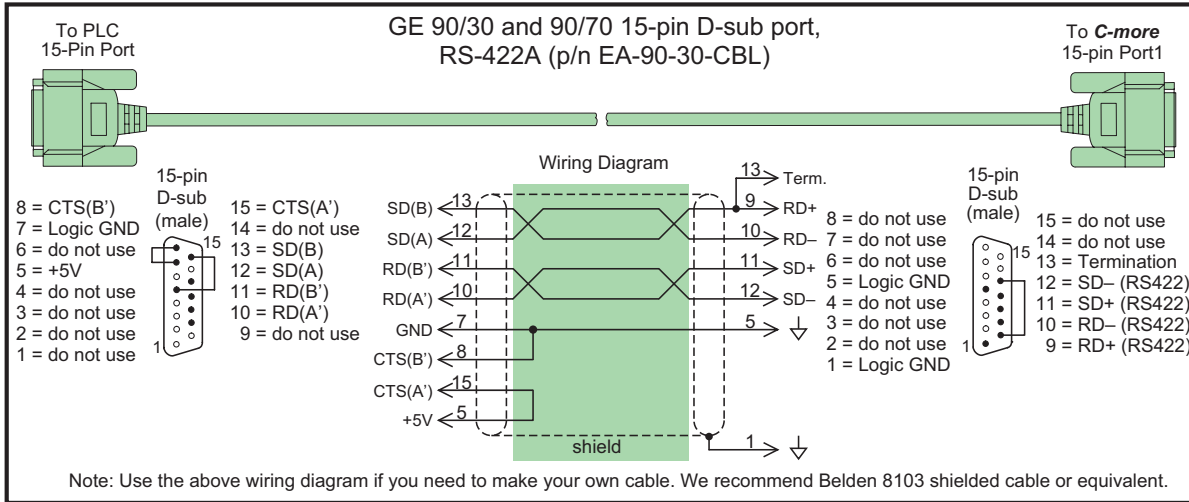

### User Constructed

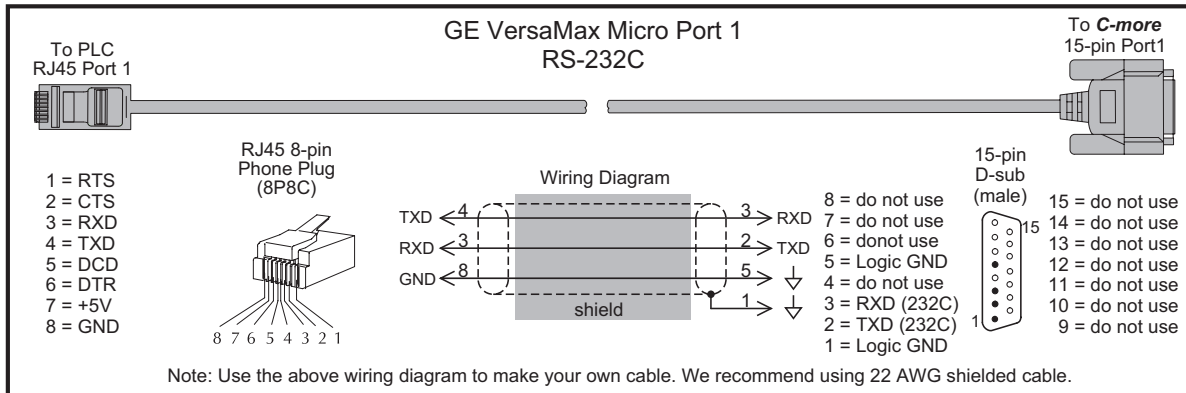

## Mitsubishi PLCs RS-422/RS-232C Serial Cables Wiring Diagrams

The following series of wiring diagrams show the connectors and wiring details for the communication cables that are used between the **C-more** touch panels and Mitsubishi PLC controllers. Part numbers are included with the pre-made cables that can be purchased from AutomationDirect. The information presented will allow the user to construct their own cables if so desired.

### EA-MITSU-CBL

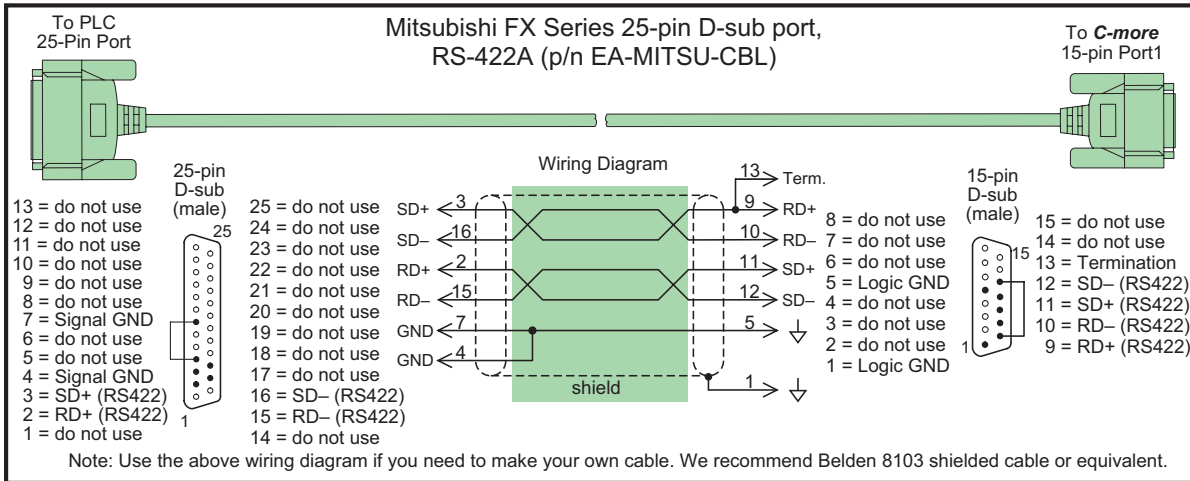

### EA-MITSU-CBL-1

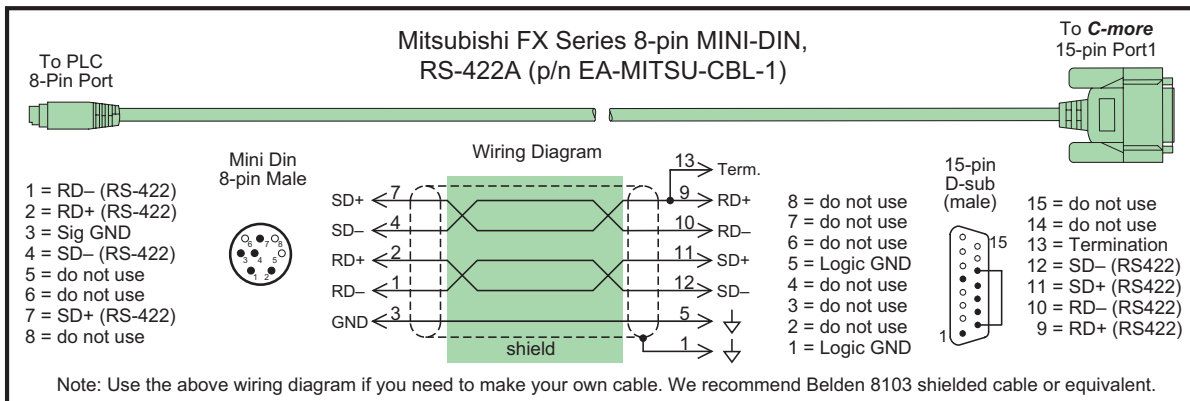

### User Constructed

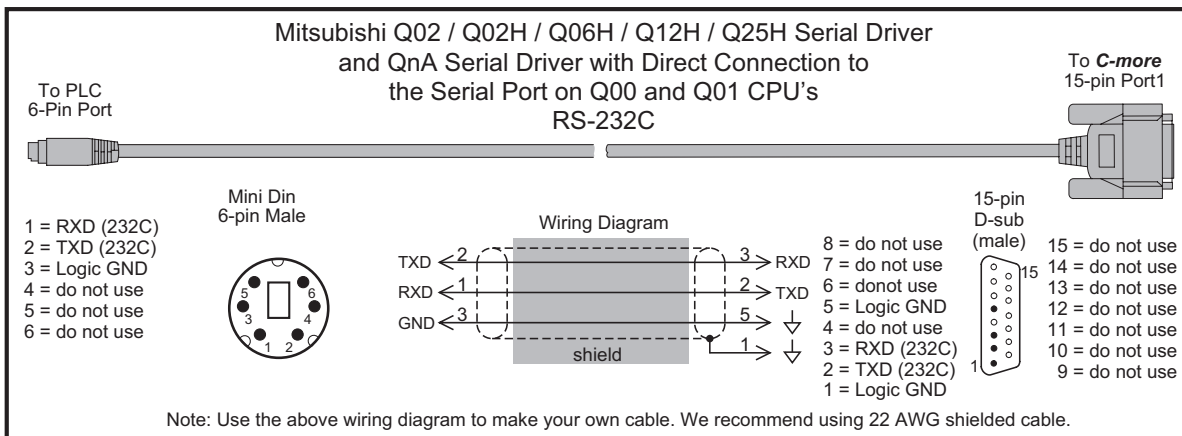

# User Constructed

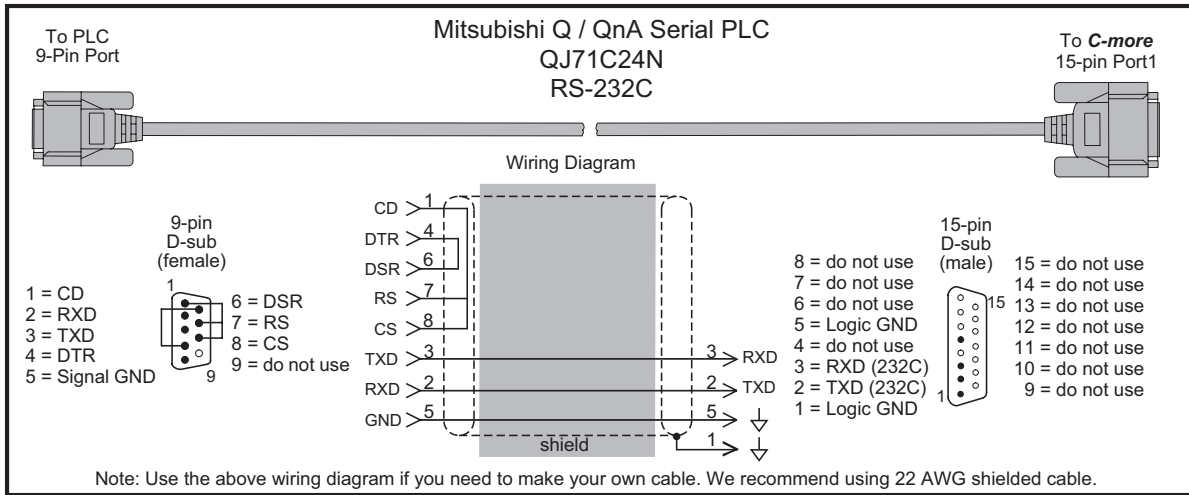



## Omron PLCs RS-232C Serial Cables Wiring Diagrams

The following series of wiring diagrams show the connectors and wiring details for the communication cables that are used between the **C-more** touch panels and Omron PLC controllers. Part numbers are included with the pre-made cables that can be purchased from AutomationDirect. The information presented will allow the user to construct their own cables if so desired.

### EA-OMRON-CBL

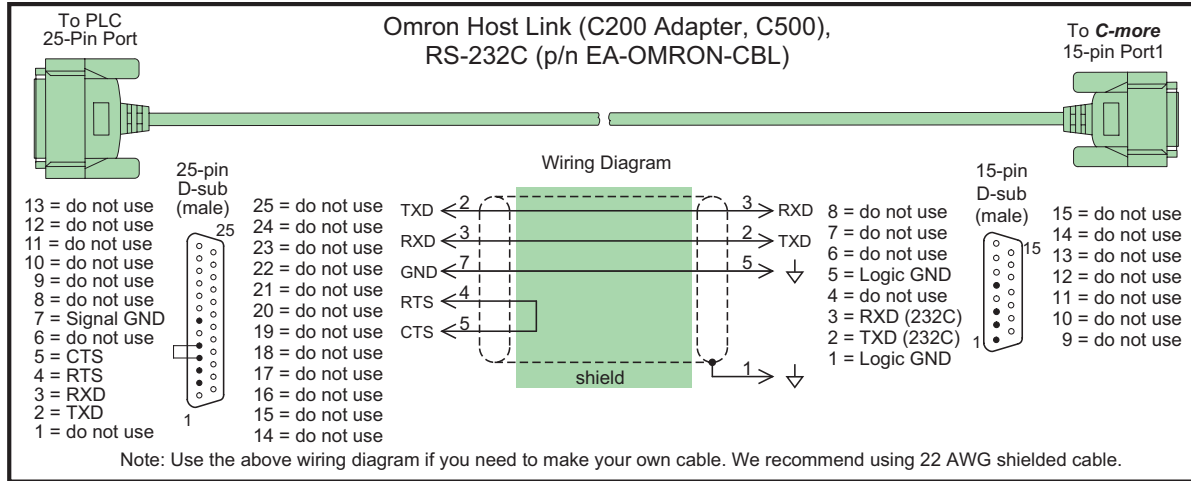

### User Constructed

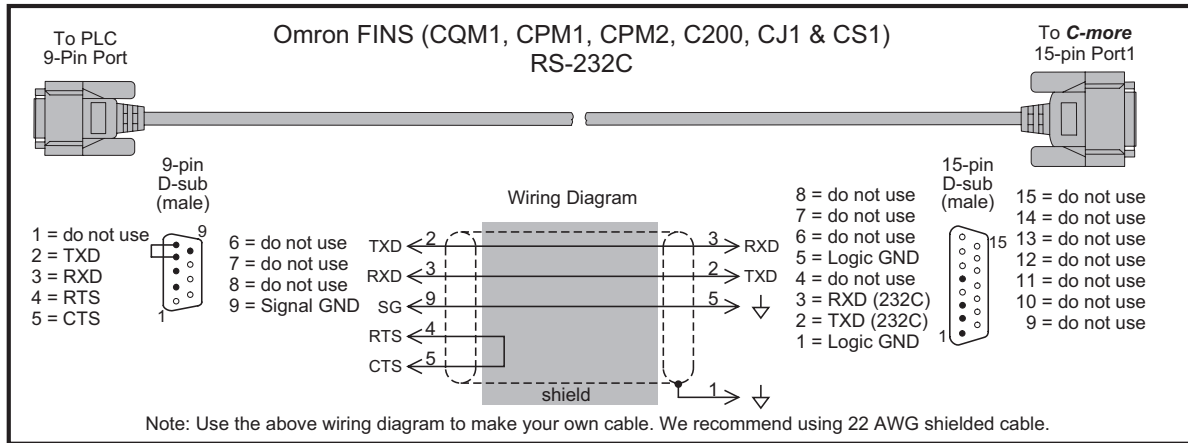

### User Constructed

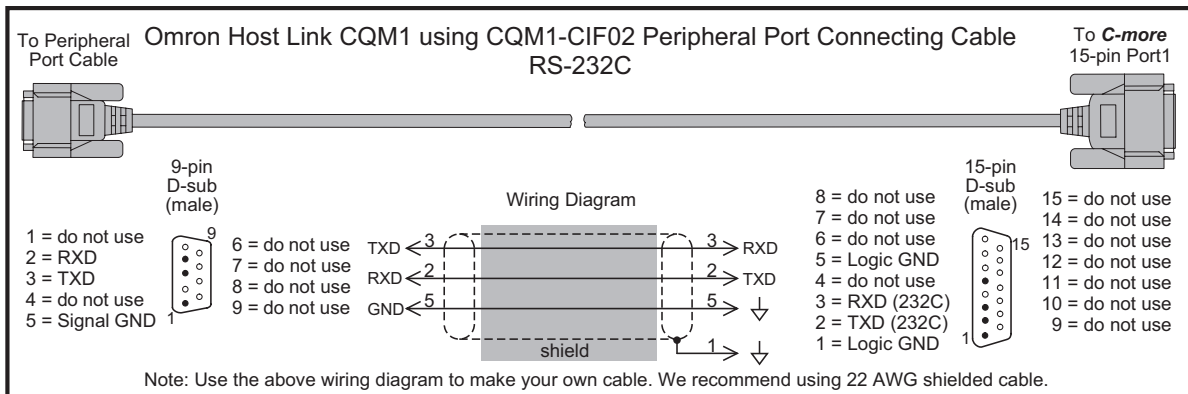

## Modicon PLCs RS-232C Serial Cables Wiring Diagrams

The following series of wiring diagrams show the connectors and wiring details for the communication cables that are used between the **C-more** touch panels and Modicon PLC controllers. The information presented will allow the user to construct their own cables.

### User Constructed

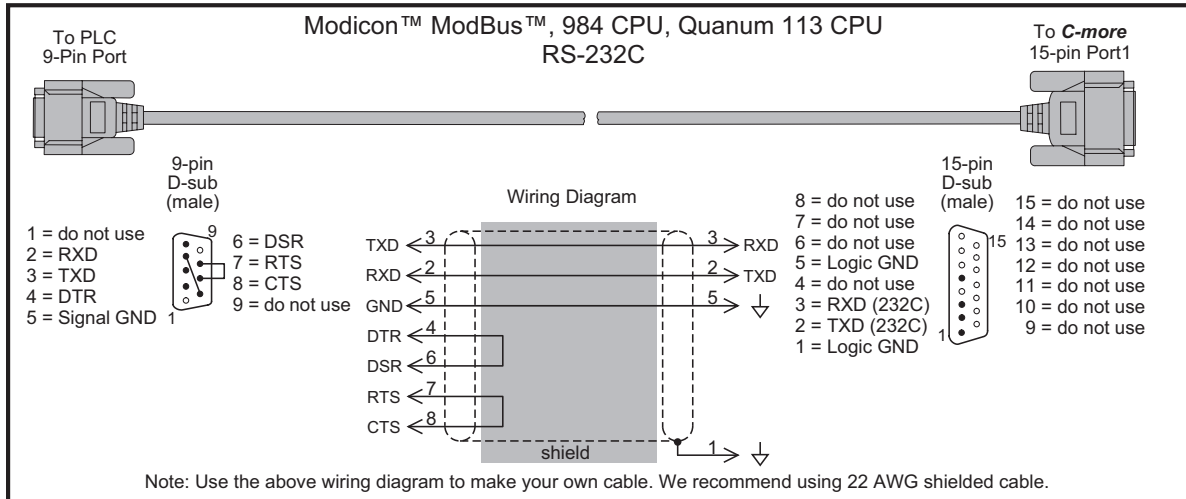

### User Constructed

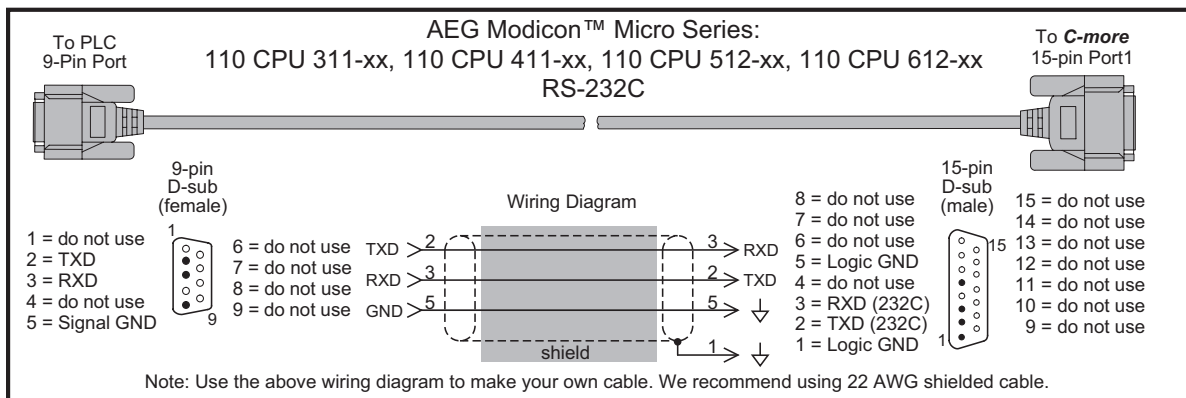

### User Constructed

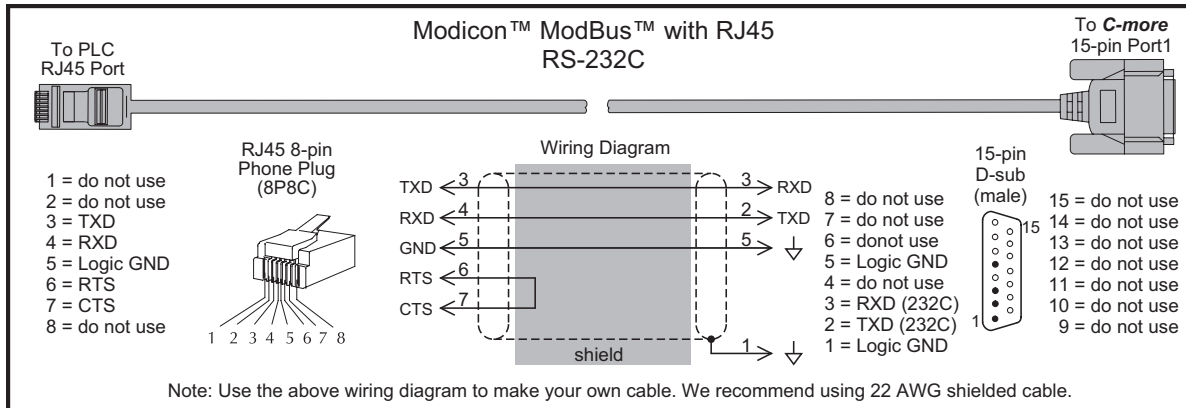

## Siemens PLCs RS-485A Serial Cables Wiring Diagrams

The wiring diagram below shows the connectors and wiring details for the communication cable that may be used between the **C-more** touch panel and Siemens PLC controller. The information presented will allow the user to construct their own cable.

### User Constructed

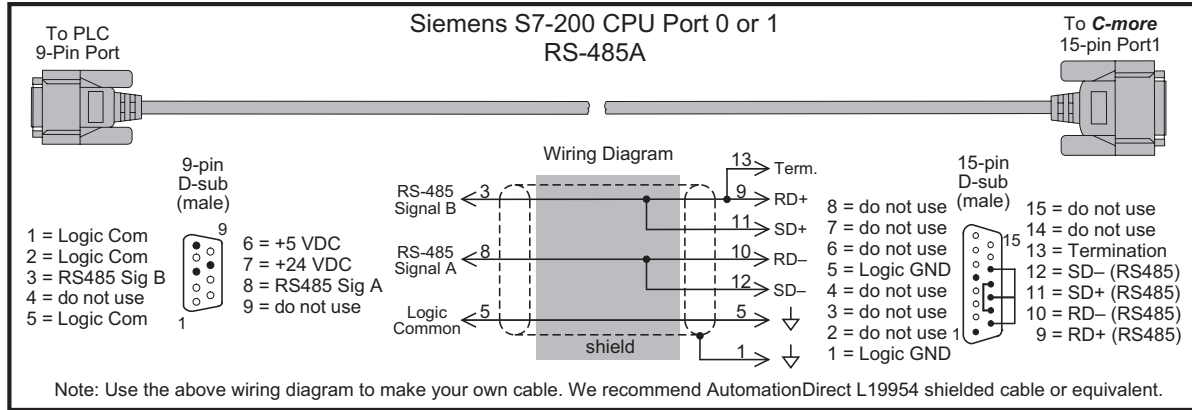

**BLANK  
PAGE**