

SPECIFICATIONS



In This Chapter...

Overview of PLC System	2-2
Regulatory and Standards Compliance.....	2-3
CLICK PLUS PLC Units	2-4
Option Slot I/O Modules	2-6
Option Slot Intelligent Modules	2-8
Stackable I/O Modules	2-9
Power Budgeting.....	2-13
PLC Unit Specifications	2-16
Option Slot I/O Module Specifications	2-31
Option Slot Intelligent Module Specifications	2-84
Stackable I/O Module Specifications.....	2-87
Power Supply Specifications.....	2-123
Programming Software	2-126
Data Types, Memory, and Numbering System	2-127
PLC Operation.....	2-131
Accessories.....	2-135

Overview of PLC System

The CLICK PLC family of components is designed to combine practical PLC features in a compact and expandable design, with a simple-to-use philosophy. A powered CLICK PLUS PLC unit by itself can be used as a complete PLC system with up to two Option Slot modules, or the system can be expanded with the addition of up to eight Stackable I/O modules. The CLICK PLC system does not require a mounting base. The CLICK PLUS PLC and I/O modules are connected together via an expansion port on the right side of the PLC case. A variety of I/O modules is available for flexible and optimal system configuration. The CLICK PLUS PLC supports a very simple but useful instruction set. There are 21 easy-to-use instructions that cover most applications that are suitable for this class of PLC.

Use a CLICK PLUS PLC unit as a stand-alone controller with Option Slot I/O...

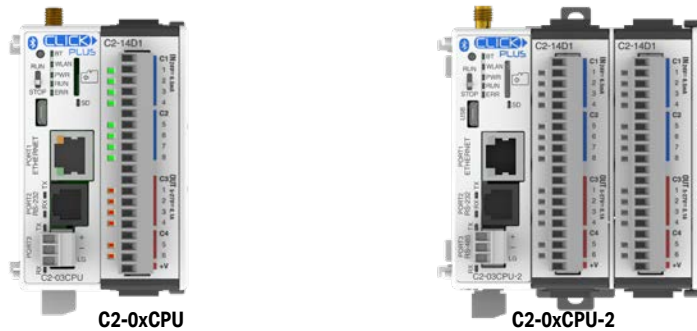

...or, expand the system by installing up to eight additional I/O modules.

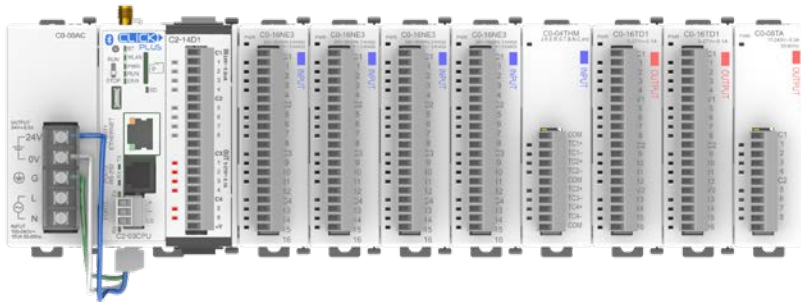

NOTE: It is not necessary to use the CLICK power supply with a CLICK PLUS PLC. An alternate, regulated, properly-sized 24VDC power source can be used to power the PLC and can also provide 24VDC to any optional I/O modules used in the CLICK PLUS PLC hardware configuration. Please refer to the Power Budgeting section later in this chapter for details on choosing the correct size power supply.

Regulatory and Standards Compliance

FCC and ISED(Canada)

Per FCC 15.19(a)(3) and (a)(4) This device complies with part 15 of the FCC Rules. Operation is subject to the following two conditions: (1) This device may not cause harmful interference, and (2) this device must accept any interference received, including interference that may cause undesired operation.

Per FCC 15.21, changes or modifications not expressly approved by the JTEKT Electronics Corporation could void the user's authority to operate the equipment.

This device complies with Industry Canada license-exempt RSS standard(s). Operation is subject to the following two conditions: (1) this device may not cause interference, and (2) this device must accept any interference, including interference that may cause undesired operation of the device.

Cet appareil est conforme à la norme RSS Industrie Canada exempt de licence. Son fonctionnement est soumis aux deux conditions suivantes: (1) cet appareil ne doit pas provoquer d'interférences et (2) cet appareil doit accepter toute interférence, y compris les interférences pouvant causer un mauvais fonctionnement du dispositif.

CLICK PLUS PLC Units

All CLICK PLUS PLC units offer the same instruction set and support CLICK PLUS Option Slot modules as well as all CLICK stackable I/O modules. The six types of PLC units available are listed in the table below.

PLC	Communication Ports						Micro SD Slot	Battery Backup	RUN time Edit
	USB	Ethernet (Port 1)	RS-232 (Port 2)	RS-485 (Port 3)	Bluetooth	WLAN			
C2-01CPU C2-01CPU-2		Yes (10/100)	Yes	None	None	None	None		
C2-02CPU C2-02CPU-2	Yes (microB)	None	None	None	Yes (external antenna required)	Yes (external antenna required)	None	Yes	Yes
C2-03CPU C2-03CPU-2		Yes (10/100)	Yes	Yes			Yes		

CLICK PLUS PLC Units

The layout of the CLICK PLUS external features is illustrated below using the C2-03CPU-2 model. Some features are not present in other models as outlined in the table above.

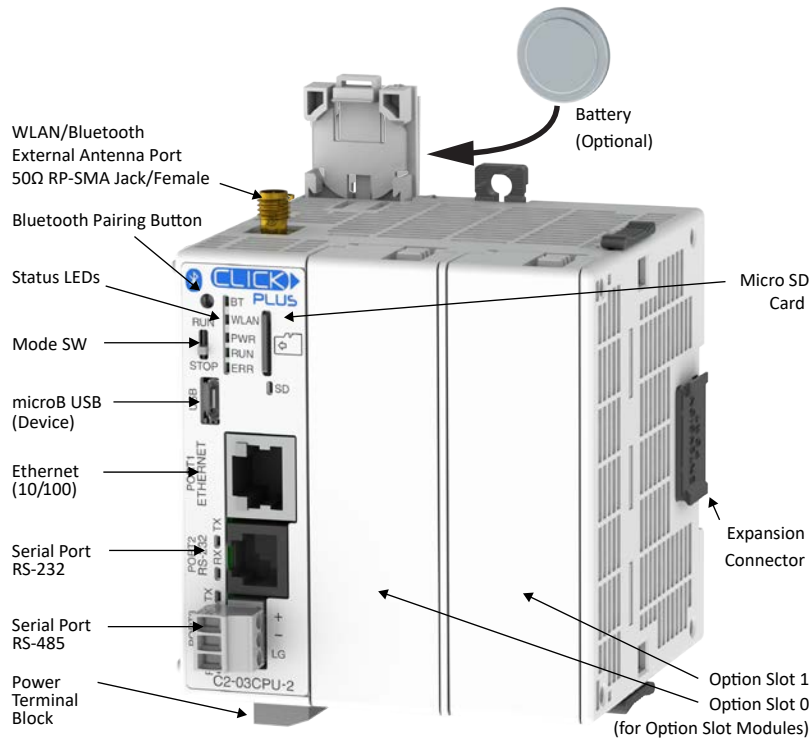

NOTE: High-speed Inputs and Outputs are only available on Slot 0.

CPU is shown with optional C2-FILL Option Slot Covers installed.

Memory

All CLICK PLUS PLC units have a non-volatile FLASH ROM to store the downloaded ladder program and project file. The FLASH ROM will retain the ladder program even with power removed from the PLC module.

The CLICK PLUS PLC units make use of data registers to store values and conditions that are used during program execution. This data is stored in the SRAM memory. It is volatile memory that is backed up by a super capacitor. This super capacitor is a special type of capacitor designed to provide power to volatile memory like the SRAM when the power to the PLC is off. However, it will not back up the memory for an extended time. In the case of the CLICK PLUS PLC, the super capacitor will back up the SRAM for approximately 1 hour after the power is shut off. Once the super capacitor is discharged, all data in the SRAM is cleared.

To prevent the loss of SRAM memory during power down, the CLICK PLUS PLCs have a battery backup feature that will retain data in the SRAM for three years. Use part number D0-MC-BAT as the replacement battery.

Refer to the PLC Unit Specifications section later in this chapter for more PLC information.



NOTE: The SD Card Memory available on the C2-03CPU and C2-03CPU-2 is only used for data logging. The PLC project and SRAM memory data are not stored on the SD Card.

Option Slot I/O Modules

The CLICK PLUS PLCs have one or two internal expansion slots (Option Slots). The first Option Slot (Slot 0) has access to a high-speed bus. A variety of Option Slot I/O modules are available, as listed below. Complete I/O module specifications and wiring diagrams can be found later in this chapter.

CLICK PLUS Option Slot I/O Modules					
Part Number	Corresponding CLICK C0 CPU	Discrete Input Types	Discrete Output Types	Analog Input Types	Analog Output Types
C2-14D1	C0-11DD1E-D	8 DC (sink/source) 8 points High-Speed**	6 DC (sink) 3 points High-Speed**	None	None
C2-14D2	C0-11DD2E-D		6 DC (source) 3 points High-Speed**		
C2-14DR	C0-11DRE-D		6 Relay		
C2-14AR	C0-11ARE-D				
C2-08D1-4VC*	C0-12DD1E-D	4 DC (sink/source) 4 points High-Speed**	4 DC (sink) 2 points High-Speed**	2 channel; voltage (0-5 VDC) / current (4-20 mA); selectable separately per channel, 12-bit	2 channel; voltage (0-5 VDC) / current (4-20 mA); selectable separately per channel, 12-bit
C2-08D2-4VC*	C0-12DD2E-D		4 DC (source) 2 points High-Speed**		
C2-08DR-4VC*	C0-12DRE-D		4 relay		
C2-08AR-4VC*	C0-12ARE-D				

* These four Option Slot modules require that you select analog I/O as voltage or current type in the CLICK programming software. See the Analog I/O Configuration section in Chapter 3.

** For high-speed inputs and outputs, the Option Slot Module must be installed in Slot 0.

Table continued on next page.

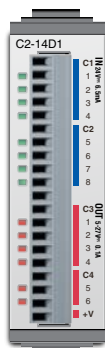

C2-14xx

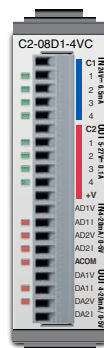

C2-08xx-4VC

CLICK PLUS Option Slot I/O Modules (continued)					
Part Number	Corresponding CLICK C0 CPU	Discrete Input Types	Discrete Output Types	Analog Input Types	Analog Output Types
C2-08D1-6C	C0-12DD1E-1-D	4 DC (sink/source) 4 points High-Speed**	4 DC (sink) 2 points High-Speed**	4 channel; current (0–20 mA), 12-bit	2 channel; current (4–20 mA), 12-bit
C2-08D2-6C	C0-12DD2E-1-D		4 DC (source) 2 points High-Speed**		
C2-08DR-6C	C0-12DRE-1-D		4 relay		
C2-08AR-6C	C0-12ARE-1-D		4 AC		
C2-08D1-6V	C0-12DD1E-2-D	4 DC (sink/source) 4 points High-Speed**	4 DC (sink) 2 points High-Speed**	4 channel; voltage (0–10 VDC), 12-bit	2 channel; voltage (0–10 VDC), 12-bit
C2-08D2-6V	C0-12DD2E-2-D		4 DC (source) 2 points High-Speed**		
C2-08DR-6V	C0-12DRE-2-D		4 relay		
C2-08AR-6V	C0-12ARE-2-D		4 AC		

* These four Option Slot modules require that you select analog I/O as voltage or current type in the CLICK programming software. See the Analog I/O Configuration section in Chapter 3.

** For high-speed inputs and outputs, the Option Slot Module must be installed in Slot 0.

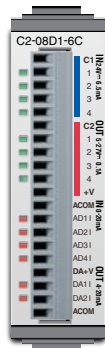

C2-08xx-6C

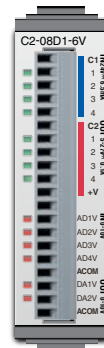

C2-08xx-6V

Option Slot Intelligent Modules

In addition to I/O modules, the Option Slots on CLICK PLUS PLCs can accept Option Slot Intelligent Modules. The first of these is the C2-DCM communications module, as shown in the table below. Complete Intelligent Module specifications and wiring diagrams can be found later in this chapter. Option Slot Intelligent Modules facilitate expansion of the capabilities of the CLICK PLUS system without requiring replacement of your existing CLICK PLUS CPU.

CLICK PLUS Option Slot Intelligent Modules	
Part Number	Description
C2-DCM	Communications module, 2 RS-232/RS-485 ports, supports Modbus RTU and ASCII.

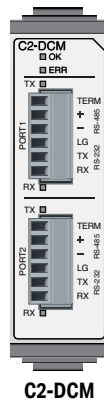

Stackable I/O Modules

A variety of I/O modules is available for the CLICK PLC System. Up to 8 I/O modules can be connected to a CLICK PLC unit to expand the system I/O count and meet the needs of a specific application. Complete I/O module specifications and wiring diagrams can be found later in this chapter. Here are the I/O modules that are supported by the CLICK PLC system.

Discrete Input Modules

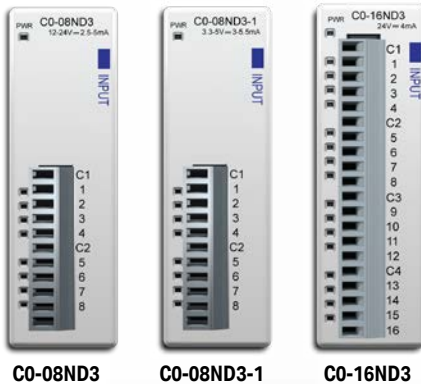

Discrete Input Modules		
Part Number	Input Type	Voltage Ratings
CO-08ND3	8 DC (Sink/Source)	12-24 VDC
CO-08ND3-1	8 DC (Sink/Source)	3.3-5 VDC
CO-16ND3	16 DC (Sink/Source)	24VDC
CO-08NE3	8 AC/DC (Sink/Source)	24 VAC/VDC
CO-16NE3	16 AC/DC (Sink/Source)	24 VAC/VDC
CO-08NA	8 AC	100-120 VAC

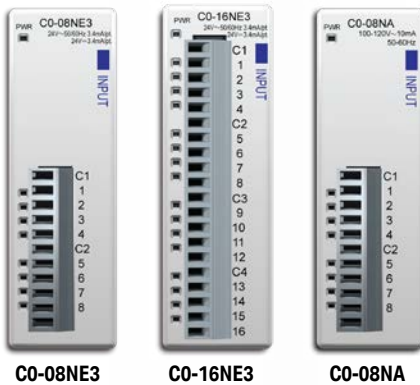

Specialty Modules

Specialty Modules		
Part Number	Input Type	Voltage Ratings
CO-08SIM	8, Toggle Switch	N/A



CO-08SIM

Discrete Output Modules

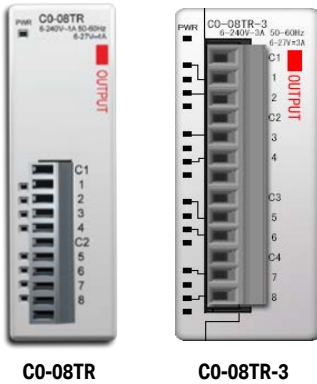
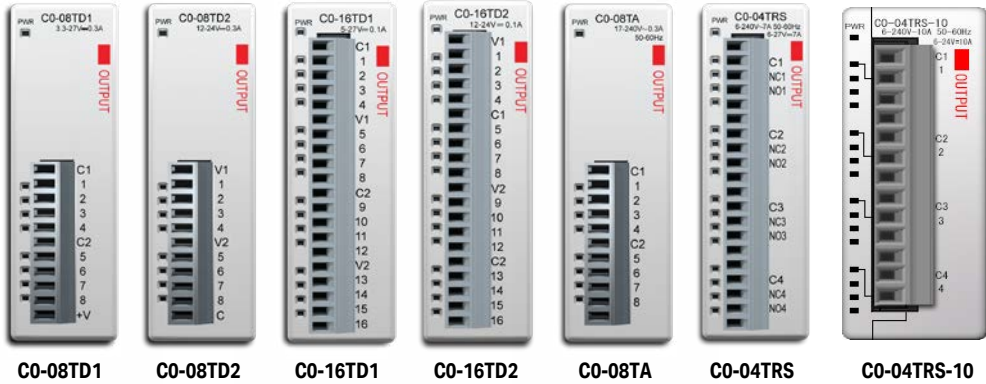

Discrete Output Modules		
Part Number	Output Type	Voltage/Current Ratings
CO-08TD1	8 DC (Sink)	3.3-27 VDC / 0.3 A
CO-08TD2	8 DC (Source)	12-24 VDC / 0.3 A
CO-16TD1	16 DC (Sink)	5-27 VDC / 0.1 A
CO-16TD2	16 DC (Source)	12-24 VDC / 0.1 A
CO-08TA	8 AC	17-240 VAC / 0.3 A
CO-04TRS	4 Relay	6-27 VDC / 7A 6-240 VAC / 7A
CO-04TRS-10	4 Relay	6-24 VDC / 10A 6-240 VAC / 10A
CO-08TR	8 Relay	6-27 VDC / 1A 6-240 VAC / 1A
CO-08TR-3	8 Relay	6-27 VDC / 3A 6-240 VAC / 3A

Discrete Combo I/O Modules

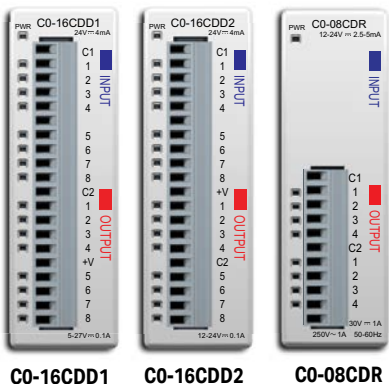

Discrete Combo I/O Modules				
Part Number	Input Type	Input Voltage	Output Type	Output Voltage / Current Ratings
CO-16CDD1	8 DC (sink/source)	24VDC	8 DC (sink)	5-27 VDC / 0.1 A
CO-16CDD2	8 DC (sink/source)	24VDC	8 DC (source)	12-24 VDC / 0.1 A
CO-08CDR	4 DC (sink/source)	12-24 VDC	4 (relay)	6.25-24 VDC / 1A 6-240 VAC / 1A

Analog Input Modules

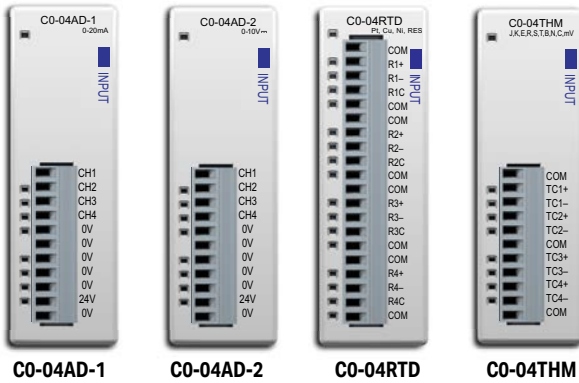

Analog Input Modules		
Part Number	Analog Input Types	External Power Required
CO-04AD-1	4 channel, current (0-20 mA), 13-bit	24VDC
CO-04AD-2	4 channel, voltage (0-10 V), 13-bit	24VDC
CO-04RTD	4 channel RTD input (0.1 degree °C/°F resolution), or resistive input (0-3125 Ω, 0.1 Ω or 0.01 Ω resolution)	None
CO-04THM	4 channel thermocouple input (0.1 degree °C/°F resolution), or voltage input (-156.25 mV to 1.25 V, 16-bit)	None

Analog Output Modules

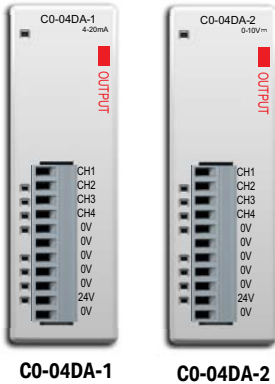

Analog Output Modules		
Part Number	Analog Output Types	External Power Required
CO-04DA-1	4 channel, current sourcing (4-20 mA), 12-bit	24VDC
CO-04DA-2	4 channel, voltage (0-10 V), 12-bit	24VDC

Analog Combo I/O Modules

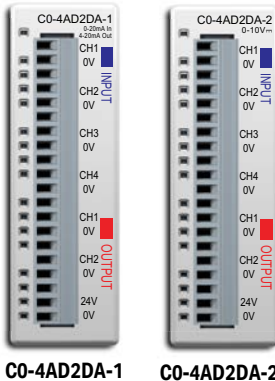

Analog Combo I/O Modules			
Part Number	Analog Input Type	Analog Output Type	External Power Required
CO-4AD2DA-1	4 channel, current (0-20 mA), 13-bit	2 channel, current sourcing (4-20 mA), 12-bit	24VDC
CO-4AD2DA-2	4 channel, voltage (0-10 V), 13-bit	4 channel, voltage (0-10 V), 12-bit	24VDC

Chapter 2: Specifications

Power Supply

Two different 24VDC power supplies are available for the CLICK PLC family. They are designed to attach to the left side of the CLICK PLC, creating a compact footprint. They are identical except for the output current rating. The 24VDC power is wired from the DC output terminals of the power supply to a removable power terminal block located on the bottom of the CLICK PLC unit.

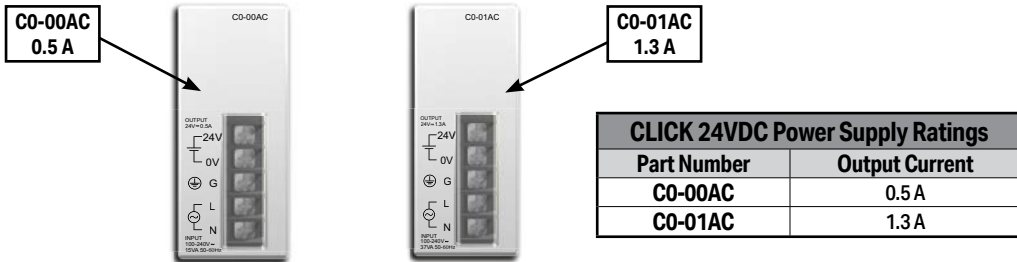

C0-00AC

The C0-00AC is a low-cost solution for applications requiring only minimal I/O and power consumption. This power supply will not support a fully-populated CLICK PLC system with all possible I/O module combinations. Please see Power Budgeting section of this chapter for details.

C0-01AC

The C0-01AC is designed to support a fully-populated CLICK PLC system with all possible I/O module combinations with no concerns of exceeding the power budget.

Please refer to the Power Supply Specifications section later in this chapter for specification details.



NOTE: It is not mandatory to use one of the above CLICK power supplies for the CLICK PLC system. A properly-sized and rated 24VDC power supply, such as some of those offered by Automationdirect.com, can also be used to power a CLICK PLC system.



12 VDC-to-24VDC Converter		
Part Number	Input Voltage	Output Current
PSP24-DC12-1	9.5-18 VDC	1.0 A @ 24VDC

PSP24-DC12-1

With this DC-DC converter you can operate the CLICK PLC with 12VDC input power.

To select a power supply to use with your CLICK PLC system, you need to consider the total PLC system's power budget. Please refer to the Power Budget section of this chapter for details.

Power Budgeting

What is Power Budgeting?

There are two areas that need to be considered when determining the power required to operate a CLICK PLUS PLC system. The first is the power required internally by the CLICK PLUS PLC. This includes the internal logic-side power that the PLC provides to its Option Slot modules, connected I/O modules that are powered through the PLC expansion port, and any device, such as a C-more Micro-Graphic panel, that is powered through one of the PLC's communication ports.

The second area is the power required by all externally-connected I/O devices. This should be viewed as the field-side power required. The field-side power is dependent on the voltage used for a particular input or output device as it relates to the wired I/O point and on the calculated load rating of the connected device

It is strongly recommended that the power source for the logic side be separate from the power source for the field side to help eliminate possible electrical noise.

Be aware that the CLICK PLUS PLC sinking DC output points require a sustained voltage to work with their output drivers. This includes the C0-08TD1 and C0-16TD1 output modules. It is recommended that this voltage be provided from the field-side power source.

The CLICK PLUS PLC operates from a 24VDC power source. The 24VDC power source can be provided by an optional CLICK PLC unit power supply (C0-00AC or C0-01AC) or one of our standard industrial 24VDC power supplies.



CLICK 24VDC Power Supply
C0-00AC or C0-01AC



Alternative 24VDC Power Supply
Example: PSP24-DC12-1

Visit www.automationdirect.com for the complete line.

Choice of the power source for the connected I/O devices is dependent on the voltage rating of the devices and the type of CLICK I/O module that is being used.

Power Budgeting requires the calculation of the total current that the 24VDC power source needs to provide to the CLICK PLUS PLC unit logic side and also a separate calculation of the total current required from all devices operating from the field side of the CLICK PLC system.

Refer to the following pages which includes tables listing the CLICK PLUS PLC and I/O module current requirements, plus a power budgeting example.

Power Budget Calculation

The following table shows the current consumption required for both the logic side and field side of the CLICK units.

PLC Current Consumption (mA)		
Part Number	Power Budget 24VDC (logic side)	External 24VDC (field side)
PLC CPU Units		
C2-01CPU	110	0
C2-02CPU	105	0
C2-03CPU	130	0
C2-01CPU-2	120	0
C2-02CPU-2	115	0
C2-03CPU-2	140	0
Option Slot I/O Modules		
C2-14D1	50	60
C2-14D2	50	0
C2-14DR	75	0
C2-14AR	75	0
C2-08D1-4VC	80	60
C2-08D2-4VC	80	0
C2-08DR-4VC	100	0
C2-08AR-4VC	100	0
C2-08D1-6C	80	60
C2-08D2-6C	80	0
C2-08DR-6C	100	0
C2-08AR-6C	100	0
C2-08D1-6V	80	60
C2-08D2-6V	80	0
C2-08DR-6V	100	0
C2-08AR-6V	100	0
Option Slot Intelligent Modules		
C2-DCM	60	0

I/O Module Current Consumption (mA)		
Part Number	Power Budget 24VDC (logic side)	External 24VDC (field side)
Discrete Input Modules		
C0-08ND3	30	0
C0-08ND3-1	30	0
C0-16ND3	40	0
C0-08NE3	30	0
C0-16NE3	40	0
C0-08NA	30	0
Discrete Output Modules		
C0-08TD1	50	15
C0-08TD2	50	0
C0-16TD1	80	100
C0-16TD2	80	0
C0-08TA	80	0
C0-04TRS	100	0
C0-04TRS-10	120	0
C0-08TR	100	0
C0-08TR-3	90	0
Discrete Combo I/O Modules		
C0-16CDD1	80	50
C0-16CDD2	80	0
C0-08CDR	80	0
Specialty Modules		
C0-08SIM	50	0
Analog Input Modules		
C0-04AD-1	20	65
C0-04AD-2	23	65
C0-04RTD	25	0
C0-04THM	25	0
Analog Output Modules		
C0-04DA-1	20	145
C0-04DA-2	20	85
Analog Combo I/O Modules		
C0-4AD2DA-1	25	75
C0-4AD2DA-2	20	65
C-more Micro-Graphic Panel (Monochrome only)		
All p/n	90	0

Power Budget Example

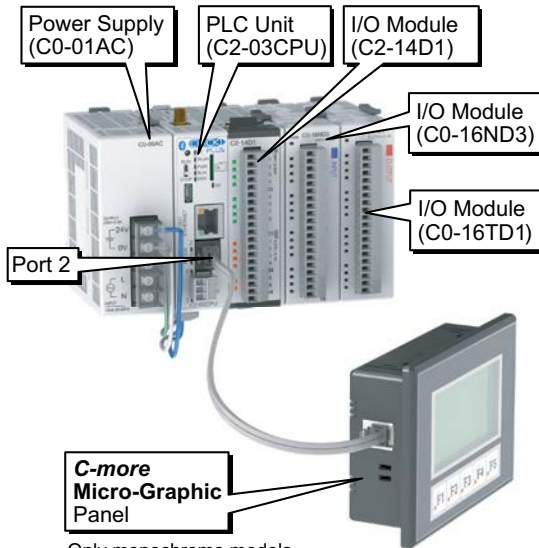

Only monochrome models can be powered from port 2.

Add the current consumption for each module in the system as shown in this example.

Current Consumption (mA)		
Part Number	Power Budget 24VDC (logic side)	External 24VDC (field side)
C2-03CPU	130	0
C2-14D1	50	60
C0-16ND3	40	0
C0-16TD1	80	100
C-more Micro	90	0
Total:	390	160 *

* Plus calculated load of connected I/O devices.

Power Budgeting using the CLICK Programming Software

The following example shows the logic-side current consumption as calculated in the System Configuration Setup section of the CLICK Programming Software. Based on the amperage rating of the power supply selected in the first column, your power budget is calculated by subtracting each consecutive module's power consumption from the total available power budget. If you exceed the maximum allowable power consumption, the power budget row fills in red.

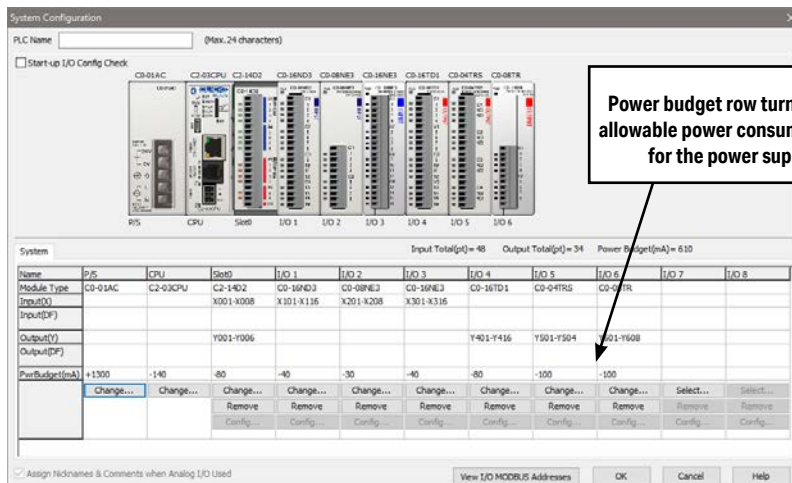

Power budget row turns red if maximum allowable power consumption is exceeded for the power supply selected.

PLC Unit Specifications

General Specifications for all CLICK PLUS CPUs

CLICK PLUS PLC Unit General Specifications	
Operating Temperature	32°F to 131°F (0°C to 55°C)
Storage Temperature	-4°F to 158°F (-20°C to 70°C) IEC 60068-2-1 (Test Ab, Cold) IEC 60068-2-2 (Test Bb, Dry Heat) IEC 60068-2-14 (Test Na, Thermal Shock)
Ambient Humidity	30% to 95% relative humidity (non-condensing)
Environmental Air	No corrosive gases The level for the environmental pollution is 2 (UL840)
Environment	For Indoor Use Only
Vibration	IEC60068-2-6 (Test Fc) 5-9Hz: 3.5mm amplitude, 9-150Hz 1.0G 10 sweep cycles per axis on each of 3 mutually perpendicular axes.
Shock	IEC60068-2-27 (Test Ea) 15G peak, 11ms duration, 3 shocks in each direction per axis, on 3 mutually perpendicular axes.
Voltage Withstand (Dielectric)	1000VAC, 1 minute (between G and 24V IN)
Insulation Resistance	500VDC, 10M ohm (between G and 24V IN)
Noise Immunity	<EN61131-2> EN61000-4-2 (ESD): 4kV (Contact Discharge) 8kV (Air Discharge) EN61000-4-3 (RFI): 10V/m (80MHz-1GHz), 3V/m (1.4GHz-2.0GHz) 1V/m(2.0GHz-2.7GHz) EN61000-4-4 (FTB) : 2kV, positive/negative, 5kHz (DC Power Port) 1kV, positive/negative, 5kHz (I/O and Communication Port) EN61000-4-5 (Surge): 0.5kV/1kV line to line 0.5kV/1kV line to earth EN61000-4-6 (Conducted): 10V, 0.15MHz - 80MHz EN61000-4-8 (Power frequency magnetic field immunity) : 30A/m <Local Test> Impulse Immunity: 1000V @ 1uS pulse
Emissions	EN55011 Class A (Radiated RF emission)
Agency Approvals	UL61010 (File No. E157382, E316037); CE (EN61131-2); CUL Canadian C22.2
Radio Standards	FCC part15C (US), RED Article3.2 (CE), IC RSS-247 (Canada), MIC Item 19 of Article 2-1 (Japan), AS/NZS 4268 (Australia/New Zealand)
Other	RoHS 2011/65/EU Amendment (EU)2015/863 Bluetooth SIG, SD associate

PLC Unit Specifications, continued

C2-01CPU



C2-01CPU-2



CLICK PLUS C2-01CPU and C2-01CPU-2 PLC Unit Specifications	
Control Method	Stored Program/Cyclic execution method
I/O Numbering System	Fixed in Decimal
Ladder Memory (steps)	8000
Total Data Memory (words)	8000
Contact Execution (boolean)	< 0.2 μ s
Typical Scan (1k boolean)	< 1ms
RLL Ladder Style Programming	Yes
Run Time Edits	Yes
Scan	Variable / fixed
PLC Mode Switch	1 (RUN/STOP)
FLASH Memory	Standard on PLC
Protocol	Modbus RTU (master/slave) and ASCII (in/out), Modbus TCP (client server), EtherNet/IP Implicit and Explicit (adapter server)
MQTT	Publisher: 4 Publishers, 3 blocks each Subscriber: 10 blocks
Data Logging	N/A
CLICK Programming Software	Yes (Windows)
Number of Instructions Available	21
Control Relays	2000
System Control Relays	1000
Timers	500
Counters	250
Interrupt	Yes (external: 8 / timed: 4)
Subroutines	Yes
For/Next Loops	Yes
Math (Integer and Hex)	Yes
Drum Sequencer Instruction	Yes
Internal Diagnostics	Yes
Password Security	Yes
System Error Log	Yes
User Error Log	No
Memory Backup	Super Capacitor + Battery
Battery Backup	Yes (battery part # DO-MC-BAT)
Calendar/Clock	Yes

PLC Unit Specifications, continued

CLICK PLUS C2-01CPU and C2-01CPU-2 PLC Unit Specifications			
		C2-01CPU	C2-01CPU-2
I/O Slot	Internal I/O	N/A (Optional)	
	Option Slot Support	Yes	
	Stackable I/O	Yes (max. 8 modules)	
Com. Ports	USB Port (Programming)	Yes (Device) (For programming and providing 5VDC power, microB USB)	
	Ethernet (RJ45)	Yes (10/100)	
	Serial Port RS-232 (RJ12)	Yes	
	Serial Port RS-485 (Terminal Block)	None	
	WLAN	None	
	Bluetooth	None	
Status Indicators	WLAN Status LED	None	
	Bluetooth Status LED	None	
	CPU Status LED	3 (PWR/RUN/ERR)	
	Ethernet Status LED	2 (LINK/ACT 10/100)	
	Serial Status LED	2 (TX/RX)	
	SD Card Status LED	None	
Other	Micro SD Card Slot (SDHC Compatible)	None	
Power	Nominal Input Voltage	24VDC (4-pin terminal block)	
	Operating Voltage Range	24VDC, Class 2 or SELV (Safety Extra-Low Voltage) or Limited Energy Circuit power supply	
	Input Voltage Range	20.0 – 28.0 VDC	
	Maximum Inrush Current	30A @ 1ms	
	Power Consumption*	20W	22W
	Acceptable External Power Drop	Max 10ms (AC Power Failure with C0-00AC or C0-01AC)	
	Current Required	110mA	120mA
	Fuse	No	
	External Fuse Recommended	No	
	Polarity Protection	Power input is reverse polarity protected	
	USB Supply	5VDC (via USB programming port)	
Communication Port & Terminal Block Replacement		N/A	
24VDC Power Terminal Block Replacement		AutomationDirect p/n C0-4TB	
Antenna Requirements		N/A	
Weight		3.5 oz [99g]	4.0 oz [114g]

* Power consumption shown is the maximum power consumption with the maximum number of I/O modules attached.

PLC Unit Specifications, continued

C2-02CPU

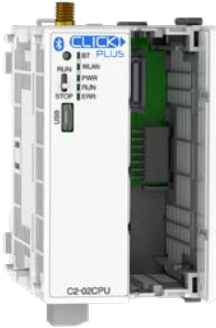

C2-02CPU-2



CLICK PLUS C2-02CPU and C2-02CPU-2 PLC Unit Specifications	
Control Method	Stored Program/Cyclic execution method
I/O Numbering System	Fixed in Decimal
Ladder Memory (steps)	8000
Total Data Memory (words)	8000
Contact Execution (boolean)	< 0.2 μ s
Typical Scan (1k boolean)	< 1ms
RLL Ladder Style Programming	Yes
Run Time Edits	Yes
Scan	Variable / fixed
PLC Mode Switch	1 (RUN/STOP)
FLASH Memory	Standard on PLC
Protocol	Modbus RTU (master/slave) and ASCII (in/out), Modbus TCP (client server)
MQTT	Publisher: 4 Publishers, 3 blocks each Subscriber: 10 blocks
Data Logging	N/A
CLICK Programming Software	Yes (Windows)
Number of Instructions Available	21
Control Relays	2000
System Control Relays	1000
Timers	500
Counters	250
Interrupt	Yes (external: 8 / timed: 4)
Subroutines	Yes
For/Next Loops	Yes
Math (Integer and Hex)	Yes
Drum Sequencer Instruction	Yes
Internal Diagnostics	Yes
Password Security	Yes
System Error Log	Yes
User Error Log	No
Memory Backup	Super Capacitor + Battery
Battery Backup	Yes (battery part # D0-MC-BAT)
Calendar/Clock	Yes

PLC Unit Specifications, continued

CLICK PLUS C2-02CPU and C2-02CPU-2 PLC Unit Specifications			
		C2-02CPU	C2-02CPU-2
I/O Slot	Internal I/O	N/A (Optional)	
	Option Slot Support	Yes	
	Stackable I/O	Yes (max. 8 modules)	
Com. Ports	USB Port (Programming)	Yes (Device) (For programming and providing 5VDC power, microB USB)	
	Ethernet (RJ45)	None	
	Serial Port RS-232 (RJ12)	None	
	Serial Port RS-485 (Terminal Block)	None	
	WLAN	Yes (RP-SMA connection for optional external antenna, shared)	
	Bluetooth		
Status Indicators	WLAN Status LED	1	
	Bluetooth Status LED	1	
	CPU Status LED	3 (PWR/RUN/ERR)	
	Ethernet Status LED	None	
	Serial Status LED	None	
	SD Card Status LED	None	
Other	Micro SD Card Slot (SDHC Compatible)	None	
Power	Nominal Input Voltage	24VDC (4-pin terminal block)	
	Operating Voltage Range	24VDC, Class 2 or SELV (Safety Extra-Low Voltage) or Limited Energy Circuit power supply	
	Input Voltage Range	20.0 – 28.0 VDC	
	Maximum Inrush Current	30A @ 1ms	
	Power Consumption*	20W	22W
	Acceptable External Power Drop	Max 10ms (AC Power Failure with C0-00AC or C0-01AC)	
	Current Required	105mA	115mA
	Fuse	No	
	External Fuse Recommended	No	
	Polarity Protection	Power input is reverse polarity protected	
	USB Supply	5VDC (via USB programming port)	
Communication Port & Terminal Block Replacement		N/A	
24VDC Power Terminal Block Replacement		AutomationDirect p/n C0-4TB	
Antenna Requirements		2.4 GHz antenna, RP-SMA connector (AutomationDirect p/n SE-ANT250 or SE-ANT210)	
Weight		3.3 oz [94g]	3.8 oz [109g]

* Power consumption shown is the maximum power consumption with the maximum number of I/O modules attached.

PLC Unit Specifications, continued

C2-03CPU



C2-03CPU-2



CLICK PLUS C2-03CPU and C2-03CPU-2 PLC Unit Specifications	
Control Method	Stored Program/Cyclic execution method
I/O Numbering System	Fixed in Decimal
Ladder Memory (steps)	8000
Total Data Memory (words)	8000
Contact Execution (boolean)	< 0.2 μs
Typical Scan (1k boolean)	< 1ms
RLL Ladder Style Programming	Yes
Run Time Edits	Yes
Scan	Variable / fixed
PLC Mode Switch	1 (RUN/STOP)
FLASH Memory	Standard on PLC
Protocol	Modbus RTU (master/slave) and ASCII (in/out), Modbus TCP (client server), EtherNet/IP Implicit and Explicit (adapter server)*
MQTT	Publisher: 4 Publishers, 3 blocks each Subscriber: 10 blocks
Data Logging	Time, Date, 16 Addresses
CLICK Programming Software	Yes (Windows)
Number of Instructions Available	21
Control Relays	2000
System Control Relays	1000
Timers	500
Counters	250
Interrupt	Yes (external: 8 / timed: 4)
Subroutines	Yes
For/Next Loops	Yes
Math (Integer and Hex)	Yes
Drum Sequencer Instruction	Yes
Internal Diagnostics	Yes
Password Security	Yes
System Error Log	Yes
User Error Log	No
Memory Backup	Super Capacitor + Battery
Battery Backup	Yes (battery part # D0-MC-BAT)
Calendar/Clock	Yes

* EtherNet/IP available on the Ethernet RJ45 port only. Not available over Wi-Fi.

PLC Unit Specifications, continued

CLICK PLUS C2-03CPU and C2-03CPU-2 PLC Unit Specifications			
		C2-03CPU	C2-03CPU-2
I/O Slot	Internal I/O	N/A (Optional)	
	Option Slot Support	Yes	
	Stackable I/O	Yes (max. 8 modules)	
Com. Ports	USB Port (Programming)	Yes (Device) (For programming and providing 5VDC power, microB USB)	
	Ethernet (RJ45)	Yes (10/100)	
	Serial Port RS-232 (RJ12)	Yes	
	Serial Port RS-485 (Terminal Block)	Yes	
	WLAN	Yes (RP-SMA connection for optional external antenna, shared)	
	Bluetooth		
Status Indicators	WLAN Status LED	1	
	Bluetooth Status LED	1	
	CPU Status LED	3 (PWR/RUN/ERR)	
	Ethernet Status LED	2 (LINK/ACT 10/100)	
	Serial Status LED	2 (TX/RX)	
	SD Card Status LED	1	
Other	Micro SD Card Slot (SDHC Compatible)	YES	
Power	Nominal Input Voltage	24VDC (4-pin terminal block)	
	Operating Voltage Range	24VDC, Class 2 or SELV (Safety Extra-Low Voltage) or Limited Energy Circuit power supply	
	Input Voltage Range	20.0 – 28.0 VDC	
	Maximum Inrush Current	30A @ 1ms	
	Power Consumption*	20W	22W
	Acceptable External Power Drop	Max 10ms (AC Power Failure with C0-00AC or C0-01AC)	
	Current Required	130mA	140mA
	Fuse	No	
	External Fuse Recommended	No	
	Polarity Protection	Power input is reverse polarity protected	
	USB Supply	5VDC (via USB programming port)	
Communication Port & Terminal Block Replacement		AutomationDirect p/n C0-3TB	
24VDC Power Terminal Block Replacement		AutomationDirect p/n C0-4TB	
Antenna Requirements		2.4 GHz antenna, RP-SMA connector (AutomationDirect p/n SE-ANT250 or SE-ANT210)	
Weight		4.0 oz [114g]	4.6 oz [129g]

* Power consumption shown is the maximum power consumption with the maximum number of I/O modules attached.

PLC Unit Specifications, continued

USB Programming Port Specifications	
Communications Ratings	USB 2.0 Full Speed (12Mbps)
Connector	Micro USB Type B
Bus Power	Yes, Max 500mA 5VDC USB Bus power supplied under the following conditions: <ul style="list-style-type: none"> • Firmware update and Project update • Stop WLAN and Bluetooth function • Stop access the modules on Stackable I/O bus • PLC in Stop Mode
Recommended Cable	AutomationDirect p/n USB-CBL-AMICB6
USB Cable Length	Max 15ft.

USB Port Pin Descriptions		
1	VBUS	5V Power supply in
2	D-	Differential signal -
3	D+	Differential signal +
4	NC	Not connected (ID not used)
5	GND	Ground



Ethernet Port Specifications	
Communications Ratings	10/100 Base-T
Cable Specifications	Category 5
Auto MDI/MDIX	Yes
Connector	RJ45
Default Settings	IP Address assigned by DHCP Fallback on DHCP Failure: <ul style="list-style-type: none"> • IP Address: 169.254.x.x (APIPA) • Subnet Mask: 255.255.0.0 • Default Gateway: 0.0.0.0

Ethernet Port Pin Descriptions		
1	TD+	Transmit Data (+)
2	TD-	Transmit Data (-)
3	RD+	Receive Data (+)
4	-	Not connected
5	-	Not connected
6	RD-	Receive Data (-)
7	-	Not connected
8	-	Not connected

8 pin RJ45 Phone Type Jack

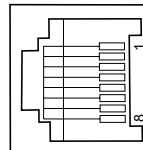

PLC Unit Specifications, continued

Micro SD Card Slot Specifications	
Card Type	microSDHC
Format	FAT32
Capacity	4GB to 32GB



NOTE: An SD card with SLC mode, such as AutomationDirect #[MSD-SLC16G](#), is strongly recommended for increased maximum lifetime write cycles.

SD Card Pin Descriptions	
1	DAT2
2	CD/DAT3
3	CMD
4	VDD
5	CLK
6	VSS
7	DAT0
8	DAT1

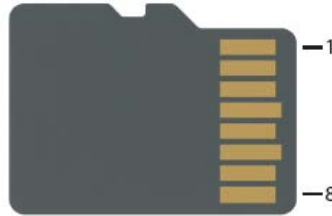

Wireless LAN (WLAN) Specifications	
Standard	IEEE 802.11/b/g/n
Frequency	2.4 GHz
Maximum Transmitting Power	20.5 dBm
Transmission Distance	Up to 30m
Line Speed	Up to 150 Mbps
WLAN Mode	Station
Security	v3.00-v3.40: WEP, WPA, WPA2; v3.42-v3.60: WPA2, WPA3
Encryption	v3.00-v3.40: AES128; v3.42-v3.60: AES128, AES192
Antenna	External (50Ω RP-SMA Jack/Female Port)
RF Certification	FCC/CE(Red)/IC/MIC/RCM
Status Lamp	WLAN(Green)

Bluetooth Specifications	
Standard	IEEE 802.15.1 v4.2 Bluetooth Low Energy
Frequency	2.4 GHz
Maximum Transmitting Power	13.4 dBm (EIRP)
Transmission Distance	Up to 10m
Line Speed	Up to 260 kbps
Antenna	External (50Ω RP-SMA Jack/Female Port)
Association Certification	Bluetooth SIG
Pairing	Yes
RF Certification	FCC/CE(Red)/IC/MIC/RCM
Status Lamp	BT (Blue)

PLC Unit Specifications, continued

RS-232 Port Specifications	
Communications Ratings	Conforms to RS-232
Communications Parameters	<ul style="list-style-type: none"> • Baud rate: 2400, 4800, 9600, 19200, 38400, 57600, 115.2k bps • Data bit: 7 bits, 8 bits • Parity: None, Odd, Even • Stop bit: 1 bit, 2 bits
Connector	RJ12 Phone Jack
Recommended Cable	AutomationDirect p/n USB-CBL-AMICB6
Power Supply to HMI (Output) (EA1 or EA3 series)	Supply 5V, 200mA

RS-232 Port Pin Descriptions		
1	GND	Ground
2	5V out	5V output, 200mA
3	RXD	Receive Data (RS-232)
4	TXD	Transmit Data (RS-232)
5	RTS	Request to Send (RS-232)
6	GND	Ground



RS-485 Port Specifications	
Communications Ratings	Conforms to RS-485
Communications Parameters	<ul style="list-style-type: none"> • Baud rate: 2400, 4800, 9600, 19200, 38400, 57600, 115.2k bps • Data bit: 7 bits, 8 bits • Parity: None, Odd, Even • Stop bit: 1 bit, 2 bits
Connector	3-wire terminal block
Terminal Type	Removable connector (Phoenix Contact MC1.5 / 3-ST-3.5GY)
Wire Size Range	16–28 AWG
Wire Specification	Supported temperature: > 60°C Material: Copper
Screw Torque	Minimum 1.95 lb-inch [0.22 N·m]
Screwdriver Size	DN-SS1 or compatible (insulated slotted screwdriver 0.4 x 2.5 x 75 mm)
Recommended Cable	Shielded cable (example FUJII ELECTRIC WIRE FKEV-SB-0.3-2P-**)
Recommended Ferrite Core	E04SR401938 (SEIWA)

RS-485 Port Pin Descriptions		
1	+	Differential Signal (+)
2	-	Differential Signal (-)
3	LG	Logic Ground

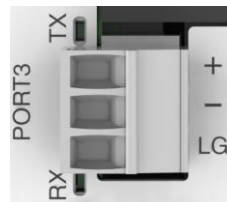

PLC Unit Specifications, continued

Power Terminal Wiring Specifications	
Terminal Type	3.5 mm pitch pluggable terminal block
Wire Range	16-28 AWG
Wire Strip Length	7.0 mm
Wire Specification	Supported temperature: > 60°C Material: Copper
Screw Torque	2.0-2.2 lb-inch [0.22-0.25 N·m]
Screw Size	M2
Number of Pins	4-pin terminal block
Screwdriver Size	DN-SS1 or compatible (insulated slotted screwdriver 0.4 x 2.5 x 75 mm)

Note: C0-00AC or C0-01AC Power Supply recommended.

Power Terminal Pinout	
24V	24V Power supply in
0V	0V Power supply reference
PF	unused
G	Ground



NOTE: DO NOT USE the PF connector. Leave this terminal unconnected. Connecting the PF terminal to another device may cause damage to the CLICK PLUS CPU.

PLC LED Status Indicators

Each CPU includes several LED Status Indicators on the front panel as described in the following illustrations.

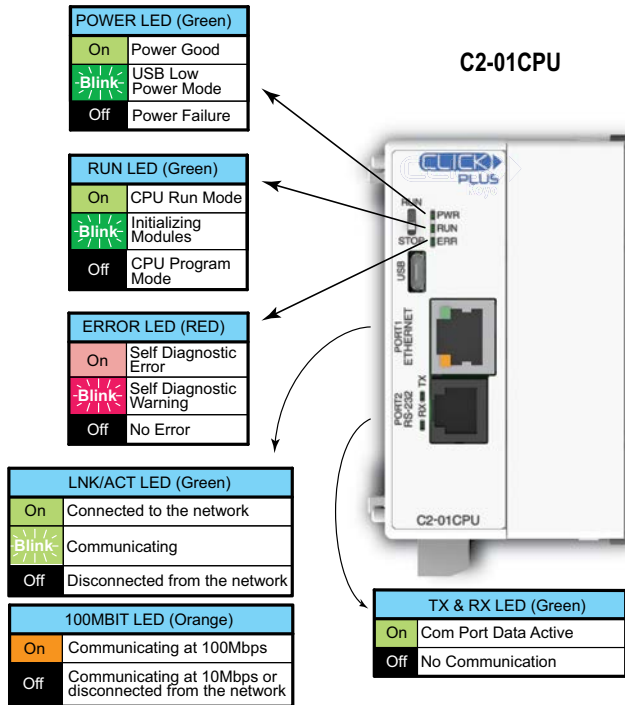

PLC LED Status Indicators, (cont'd)

WLAN LED (Green)	
On	Link
Blink	Activity
Off	No Link

POWER LED (Green)	
On	Power Good
Blink	USB Low Power Mode
Off	Power Failure

RUN LED (Green)	
On	CPU Run Mode
Blink	Initializing Modules
Off	CPU Program Mode

ERROR LED (RED)	
On	Self Diagnostic Error
Blink	Self Diagnostic Warning
Off	No Error

BLUETOOTH LED (Blue)	
On	Link
Blink	Activity (per packet)
Blink	Pairing Mode (500ms flash)
Blink	Disabled in PLC* (200ms flash)
Off	No Link

*Error - Bluetooth disabled in PLC (SC60) is On. Pairing mode disabled.

C2-02CPU

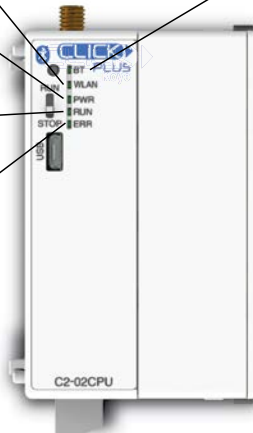

WLAN LED (Green)	
On	Link
Blink	Activity
Off	No Link

BLUETOOTH LED (Blue)	
On	Link
Blink	Activity (per packet)
Blink	Pairing Mode (500ms flash)
Blink	Disabled in PLC* (200ms flash)
Off	No Link

*Error - Bluetooth disabled in PLC (SC60) is On. Pairing mode disabled.

C2-03CPU

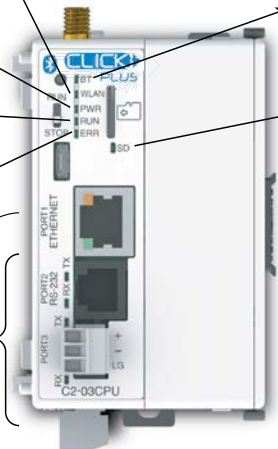

POWER LED (Green)	
On	Power Good
Blink	USB Low Power Mode
Off	Power Failure

RUN LED (Green)	
On	CPU Run Mode
Blink	Initializing Modules
Off	CPU Program Mode

ERROR LED (RED)	
On	Self Diagnostic Error
Blink	Self Diagnostic Warning
Off	No Error

MICRO SD LED (Green)	
On	Mounted
Blink	Access
Off	No SD Mounted











LNK/ACT LED (Green)	
On	Connected to the network
Blink	Communicating
Off	Disconnected from the network

TX & RX LED (Green)	
On	Com Port Data Active
Off	No Communication

100MBIT LED (Orange)	
On	Communicating at 100Mbps
Off	Communicating at 10Mbps or disconnected from the network

Memory Map

All of the CLICK PLC units support the same memory map. The CLICK PLC uses decimal numbers for the memory addressing. See page 2-127 for the definitions of each data type and memory type.

Memory Type	Symbol	Data Type	S/W Icon	Range
Input Point	X	Bit		X001 – X816
Output Point	Y			Y001 – Y816
Control Relay	C			C1 – C2000
Timer	T			T1 – T500
Counter	CT			CT1 – CT250
System Control Bit	SC			SC1 – SC1000
Data Register	DS	Integer		DS1 – DS4500
	DD	Integer2		DD1 – DD1000
	DH	HEX		DH1 – DH500
	DF	Floating Point		DF1 – DF500
Input Register	XD	HEX		XD0 – XD8
Output Register	YD			YD0 – YD8
Timer Register	TD	Integer		TD1 – TD500
Counter Register	CTD	Integer2		CTD1 – CTD250
System Data Register	SD	Integer		SD1 – SD1000
Text	TXT	Text		TXT1 – TXT1000

CLICK Programming Software PID Specifications

PID Specifications	
PID maximum number of loops	8
Required Memory	40 C bits, 15 DS registers, 25 DF registers
Control Algorithm	Position
Control Loop Action	Direct-acting or Reverse-acting
Error Term	Linear or Squared
Error Dead band	Configurable
Proportional Gain	0.01–10000
Reset Time (Integral)	0.01–6000
Derivative Gain	0.0–6000
Sampling rate	100ms to 30000ms
Loop Calculation	PID or PI
PV Filter	Configurable
Set Point	Maximum and minimum values can be set
Control Output	Maximum and minimum values can be set
Derivative Gain Limit	Configurable
Bias Freeze (Anti-Windup)	Yes
Bumpless Transfer	2 Modes
Pulse Width Modulation (PWM) Output	Yes, up to 600 second period
Auto Tuning	Ziegler-Nichols Limit Cycle
Alarms	
PV Alarm	PV alarm value can be set at Low-low, Low, High, High-high condition
Deviation Alarm	Specify alarms for two ranges of PV deviation from the setpoint value
PV Rate of Change	Detect when PV exceeds a rate of change limit you specify

CLICK PLUS PLC Hardware/Software Compatibility

CLICK programming software version 3.00 or higher is required to utilize the CLICK PLUS CPUs and Option Slot I/O modules.

CLICK programming software version 3.20 or higher is required to utilize the CLICK PLUS 2-slot CPUs and Option Slot Intelligent module C2-DCM.

Option Slot I/O Module Specifications

General Specifications for all CLICK PLUS Option Slot I/O Modules

CLICK PLUS Option Slot Module General Specifications	
Operating Temperature	32°F to 131°F [0°C to 55°C]
Storage Temperature	-4°F to 158°F [-20°C to 70°C] IEC 60068-2-1 (Test Ab, Cold) IEC 60068-2-2 (Test Bb, Dry Heat) IEC 60068-2-14 (Test Na, Thermal Shock)
Ambient Humidity	30% to 95% relative humidity (non-condensing)
Environmental Air	No corrosive gases The level for the environmental pollution is 2 (UL840)
Environment	For Indoor Use Only
Vibration	IEC60068-2-6 (Test Fc) 5-9Hz:3.5mm amplitude, 9-150Hz 1.0G 10 sweep cycles per axis on each of 3 mutually perpendicular axes.
Shock	IEC60068-2-27 (Test Ea) 15G peak, 11ms duration, 3 shocks in each direction per axis, on 3 mutually perpendicular axes.
Noise Immunity	<EN61131-2> EN61000-4-2 (ESD) EN61000-4-3 (RFI) EN61000-4-4 (FTB) EN61000-4-6 (Conducted) EN61000-4-8 (Power frequency magnetic field immunity) <Local Test> Impulse Immunity : 1000V @ 1uS pulse
Emissions	EN55011 Class A (Radiated RF emission)
Agency Approvals	UL61010 (File No. E157382, E316037); CE (EN61131-2); CUL Canadian C22.2
Other	RoHS 2011/65/EU Amendment (EU)2015/863 Bluetooth SIG, SD associate

C2-14D1 – 8 DC Input/6 Sinking DC Output Option Slot I/O Module

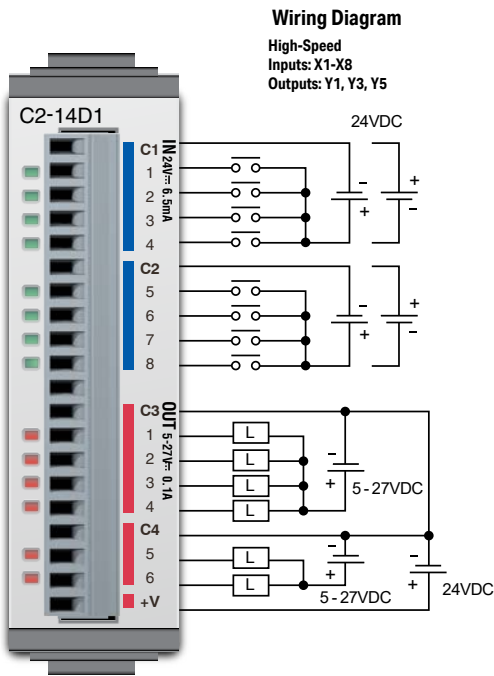

I/O Specifications - Inputs	
Inputs per Module	8 (Sink/Source)
Operating Voltage Range	24VDC
Input Voltage Range	21.6 – 26.4 VDC
Input Current	Typ 6.5 mA @ 24VDC
Maximum Input Current	7.0 mA @ 26.4 VDC
Input Impedance	3.9 kΩ @ 24VDC
Input Frequency (Max)	X1-X8: 100kHz (3m cable)
ON Voltage Level	> 19VDC
OFF Voltage Level	< 2VDC
Minimum ON Current	4.5 mA
Maximum OFF Current	0.5 mA
OFF to ON Response	Typ 3μs Max 5μs
ON to OFF Response	Typ 1μs Max 3μs
Status Indicators	Logic Side (8 points, green LED)
Commons	2 (4 points/common) Isolated

General Specifications	
Current Consumption at 24VDC	50mA max (All Points On)
Terminal Block Replacement Part No.	C0-16TB
Weight	48g

Maximum Number of High Speed Counters	
Up	6
Down	6
Up/Down	3
Pulse/Direction	4
Quadrature A-B	4
Quadrature A-B+Z	2

Equivalent Input Circuit

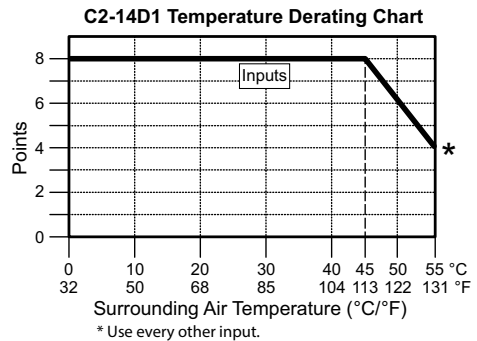
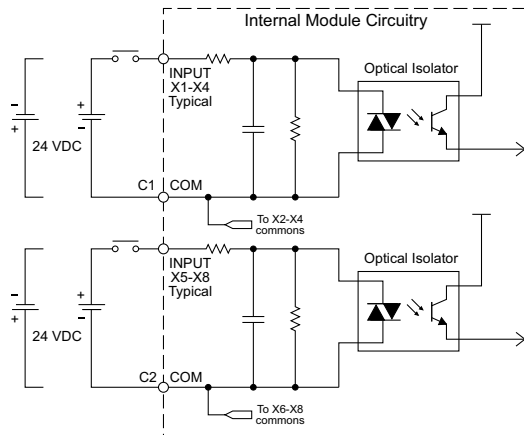

C2-14D1 – 8 DC Input/6 Sinking DC Output Option Slot I/O Module (continued)

I/O Specifications - Outputs	
Outputs per Module	6 (Sink)
Operating Voltage Range	5-27 VDC
Output Voltage Range	4-30 VDC
Maximum Output Current	0.1 A/point; C3: 0.4 A/common, C4: 0.2 A/common
Minimum Output Current	0.2 mA
Maximum Leakage Current	0.1 mA @ 30.0 VDC
On Voltage Drop	0.5 VDC @ 0.1 A
Maximum Inrush Current	150mA for 10ms
Output Frequency (Max)	Y1, Y3, Y5: 100kHz (3m cable)
OFF to ON Response	< 5µs (Duty 40-60%, Load current 20mA)
ON to OFF Response	< 5µs (Duty 40-60%, Load current 20mA)
Status Indicators	Logic Side (6 points, red LED)
Commons	2 (4 points/com & 2 points/com)
External DC Power Required	20-28 VDC Maximum @ 60mA (All Points On)

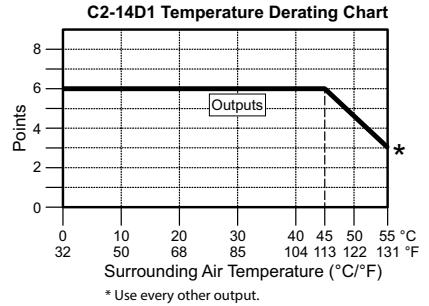

Maximum Number of High Speed Outputs	
Pulse Train	3
Pulse Width Modulation	3

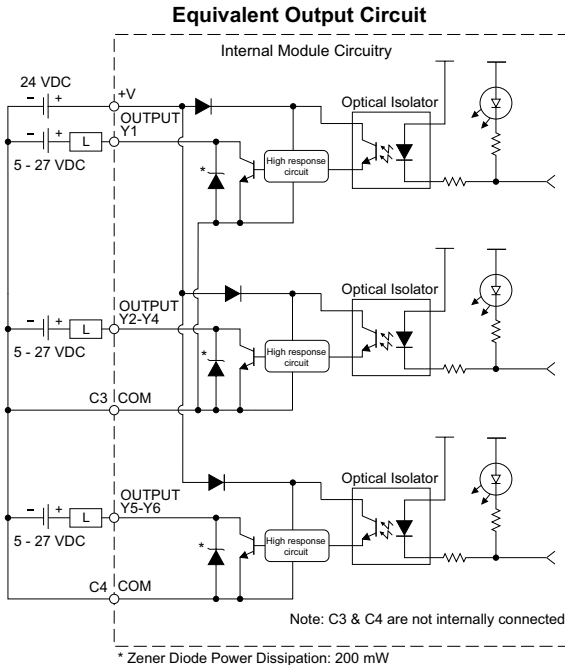

ZIPLink Pre-Wired PLC Connection Cables and Modules for CLICK PLC

20-pin connector cable
 ZL-C0-CBL20 (0.5 m length)
 ZL-C0-CBL20-1 (1.0 m length)
 ZL-C0-CBL20-2 (2.0 m length)



ZL-RTB20
 20-pin feed-through connector module



C2-14D2 – 8 DC Input/6 Sourcing DC Output Option Slot I/O Module

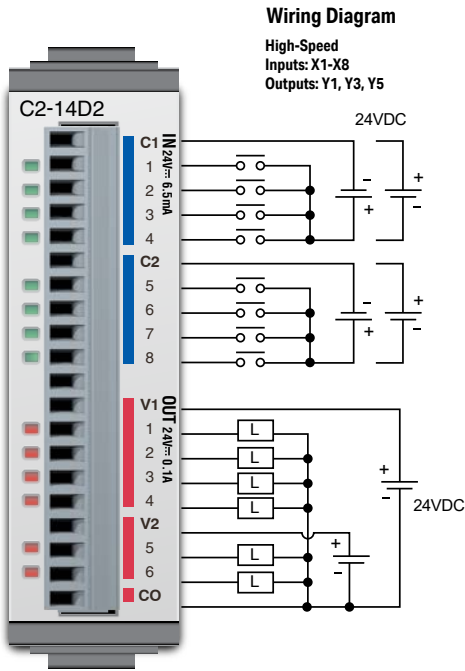

I/O Specifications - Inputs	
Inputs per Module	8 (Sink/Source)
Operating Voltage Range	24VDC
Input Voltage Range	21.6 – 26.4 VDC
Input Current	Typ 6.5 mA @ 24VDC
Maximum Input Current	7.0 mA @ 26.4 VDC
Input Impedance	3.9 kΩ @ 24VDC
Input Frequency (Max)	X1-X8: 100kHz (3m cable)
ON Voltage Level	> 19VDC
OFF Voltage Level	< 2VDC
Minimum ON Current	4.5 mA
Maximum OFF Current	0.5 mA
OFF to ON Response	Typ 3μs Max 5μs
ON to OFF Response	Typ 1μs Max 3μs
Status Indicators	Logic Side (8 points, green LED)
Commons	2 (4 points/common) Isolated

General Specifications	
Current Consumption at 24VDC	50mA max (All Points On)
Terminal Block Replacement Part No.	CO-16TB
Weight	47g

Maximum Number of High Speed Counters	
Up	6
Down	6
Up/Down	3
Pulse/Direction	4
Quadrature A-B	4
Quadrature A-B+Z	2

Equivalent Input Circuit

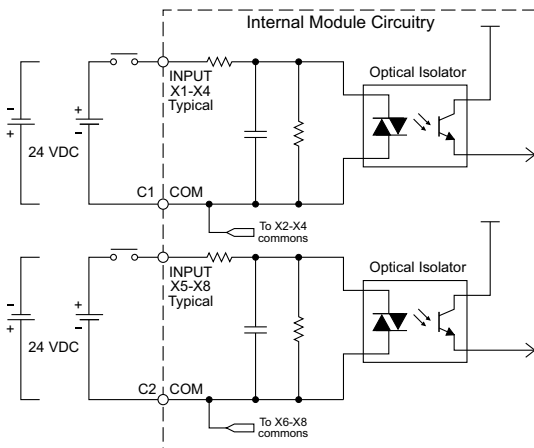

C2-14D2 Temperature Derating Chart

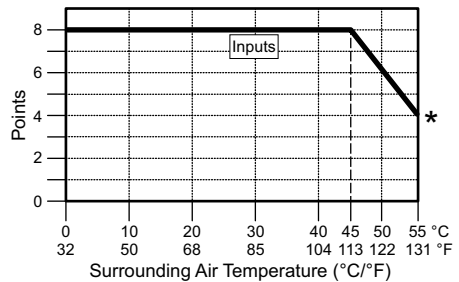

C2-14D2 – 8 DC Input/6 Sourcing DC Output Option Slot I/O Module (continued)

I/O Specifications - Outputs	
Outputs per Module	6 (Source)
Operating Voltage Range	24VDC
Output Voltage Range	19.2-30 VDC
Maximum Output Current	0.1 A/point, 0.6 A/common
Minimum Output Current	0.2 mA
Maximum Leakage Current	0.1 mA @ 30VDC
On Voltage Drop	0.5 VDC @ 0.1 A
Maximum Inrush Current	150mA for 10ms
Output Frequency (Max)	Y1, Y3, Y5: 100kHz (3m cable)
OFF to ON Response	< 5µs (Duty 40-60%, Load current 20mA)
ON to OFF Response	< 5µs (Duty 40-60%, Load current 20mA)
Status Indicators	Logic Side (6 points, red LED)
Commons	1 (6 points/common)

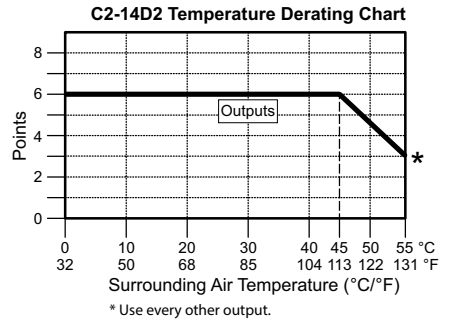

Maximum Number of High Speed Outputs	
Pulse Train	3
Pulse Width Modulation	3

Equivalent Output Circuit

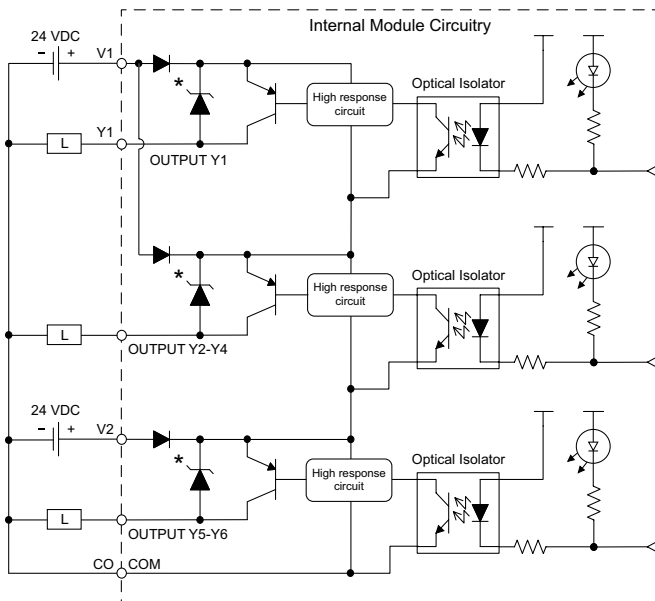

*Zener Diode Power Dissipation: 200 mW

ZIPLink Pre-Wired PLC Connection Cables and Modules for CLICK PLC

- 20-pin connector cable
- ZL-CO-CBL20 (0.5 m length)
- ZL-CO-CBL20-1 (1.0 m length)
- ZL-CO-CBL20-2 (2.0 m length)



- ZL-RTB20
- 20-pin feed-through connector module



C2-14DR – 8 DC Input/6 Relay Output Option Slot I/O Module

Wiring Diagram

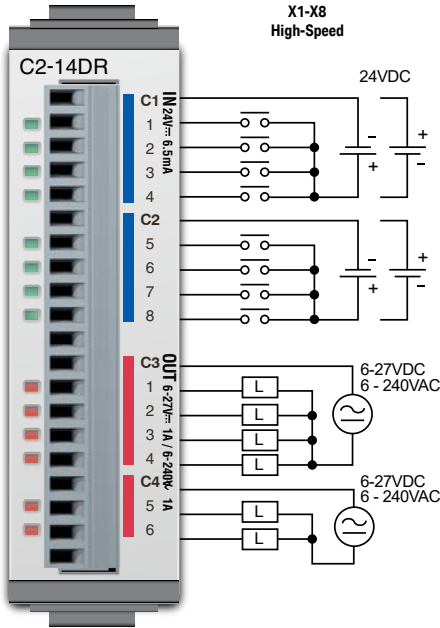

I/O Specifications - Inputs	
Inputs per Module	8 (Sink/Source)
Operating Voltage Range	24VDC
Input Voltage Range	21.6 – 26.4 VDC
Input Current	Typ 6.5 mA @ 24VDC
Maximum Input Current	7.0 mA @ 26.4 VDC
Input Impedance	3.9 kΩ @ 24VDC
Input Frequency (Max)	X1-X8: 100kHz (3m cable)
ON Voltage Level	> 19VDC
OFF Voltage Level	< 2VDC
Minimum ON Current	4.5 mA
Maximum OFF Current	0.5 mA
OFF to ON Response	Typ 3µs Max 5µs
ON to OFF Response	Typ 1µs Max 3µs
Status Indicators	Logic Side (8 points, green LED)
Commons	2 (4 points/common) Isolated

General Specifications	
Current Consumption at 24VDC	75mA max (All Points On)
Terminal Block Replacement Part No.	C0-16TB
Weight	62g

Maximum Number of High Speed Counters	
Up	6
Down	6
Up/Down	3
Pulse/Direction	4
Quadrature A-B	4
Quadrature A-B+Z	2

Equivalent Input Circuit

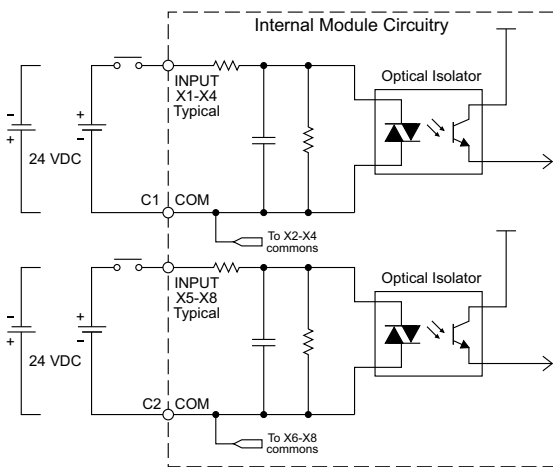

C2-14DR Temperature Derating Chart

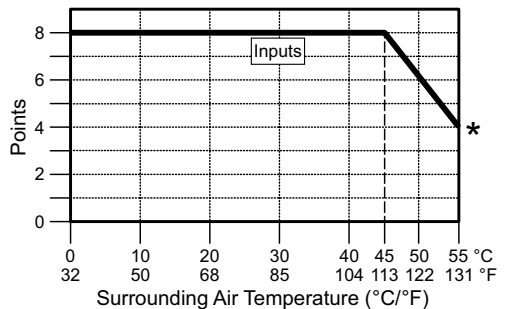

C2-14DR – 8 DC Input/6 Relay Output Option Slot I/O Module (continued)

I/O Specifications - Outputs	
Outputs per Module	6
Operating Voltage Range	6-240 VAC (47-63 Hz), 6-27 VDC
Output Voltage Range	5-264 VAC (47-63 Hz), 5-30 VDC
Output Type	Relay, form A (SPST)
Maximum Current	1A/point; C3: 4A/common, C4: 2A/common
Minimum Load Current	5mA @ 5VDC
Maximum Inrush Current	3A for 10ms
OFF to ON Response	< 15ms
ON to OFF Response	< 15ms
Status Indicators	Logic Side (6 points, red LED)
Commons	2 (4 points/com & 2 points/com) Isolated

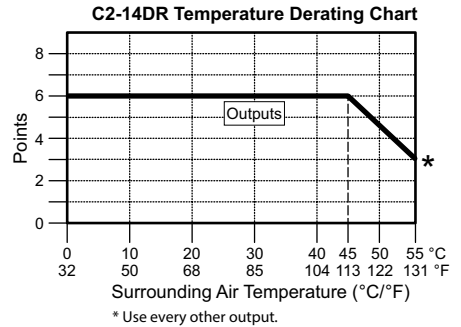

Typical Relay Life (Operations) at Room Temperature	
Voltage & Load Type	Relay Life
30VDC, 1A Resistive	200,000 cycles
30VDC, 1A Inductive	100,000 cycles
250VAC, 1A Resistive	200,000 cycles
250VAC, 1A Inductive	50,000 cycles
ON to OFF = 1 cycle	

Equivalent Output Circuit

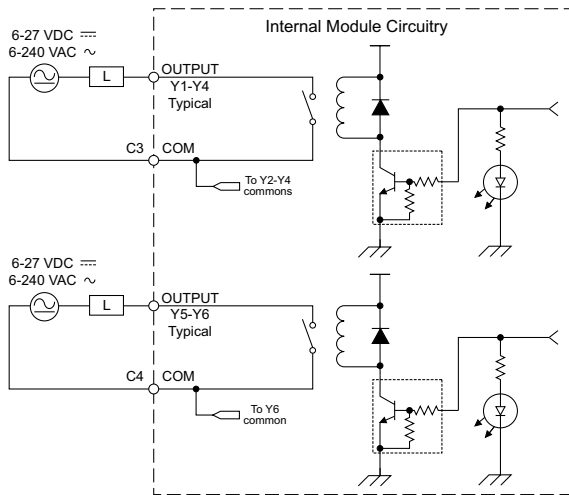

ZIPLink Pre-Wired PLC Connection Cables and Modules for CLICK PLC

- 20-pin connector cable
- ZL-C0-CBL20 (0.5 m length)
- ZL-C0-CBL20-1 (1.0 m length)
- ZL-C0-CBL20-2 (2.0 m length)



- ZL-RTB20
- 20-pin feed-through connector module



NOTE: The C2-14DR is derated to 2A maximum per Common when used with the ZIPLink wiring system.

Insulation Requirements for IEC/UL 61010-1 and 61010-2-201 (sections 6.5 and 6.7)

Input to Output Insulation

Basic insulation is provided between Relay Output 1 and the closest Input terminal. When connecting the Relay Output to a circuit that exceeds 100VAC (141VDC) more than the closest input circuit an additional basic insulation layer must be added to the input circuit.

Output to Output Insulation

Basic insulation is provided between Relay Outputs. When connecting a Relay Output to a circuit that exceeds 100VAC (141VDC) more than the adjacent Relay Outputs, an additional basic insulation layer must be added to the adjacent Relay Output circuits.

Additional Basic Insulation Examples

- Supplementary Insulation: Interposing relay, additional insulating material,... (sec. 6.5.3)
- Automatic Disconnection of the Supply: Properly sized breaker (sec. 6.5.5)
- Current or Voltage Limiting device: Properly sized fuse (sec. 6.5.6)

Basic insulation requires a clearance distance of 1.5 mm or more, a creepage distance of 2.5 mm or more, and dielectric voltage withstand of 1500Vrms.

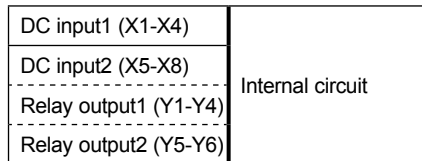

- : No insulation
- - - - - : Basic insulation
- : Reinforced insulation

C2-14AR – 8 AC Input/6 Relay Output Option Slot I/O Module

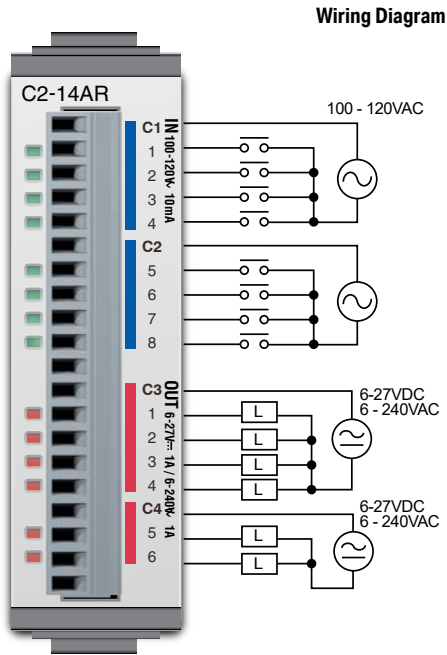

I/O Specifications - Inputs	
Inputs per Module	8
Operating Voltage Range	100-120 VAC
Input Voltage Range	80-144 VAC
AC Frequency	47-63 Hz
Input Current	8.5 mA @ 100VAC at 50Hz 10mA @ 100VAC at 60Hz
Maximum Input Current	16mA @ 144VAC
Input Impedance	15kΩ @ 50Hz 12kΩ @ 60Hz
ON Voltage Level	> 60VAC
OFF Voltage Level	< 20VAC
Minimum ON Current	5mA
Maximum OFF Current	2mA
OFF to ON Response	< 40ms
ON to OFF Response	< 40ms
Status Indicators	Logic Side (8 points, green LED)
Commons	2 (4 points/common) Isolated

General Specifications	
Current Consumption at 24VDC	75mA max (All Points On)
Terminal Block Replacement Part No.	C0-16TB
Weight	63g

Equivalent Input Circuit

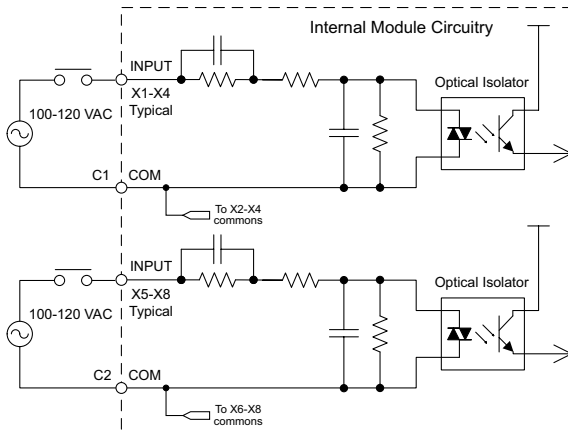

C2-14AR Temperature Derating Chart

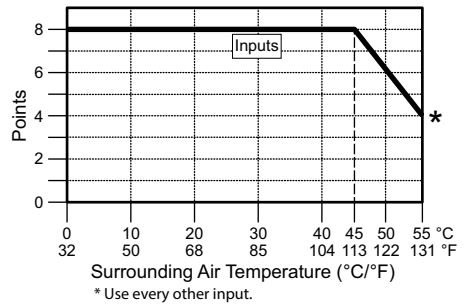

C2-14AR – 8 AC Input/6 Relay Output Option Slot I/O Module (continued)

I/O Specifications - Outputs	
Outputs per Module	6
Operating Voltage Range	6–240 VAC (47–63 Hz), 6–27 VDC
Output Voltage Range	5–264 VAC (47–63 Hz), 5–30 VDC
Output Type	Relay, form A (SPST)
Maximum Current	1A/point; C3: 4A/common, C4: 2A/common
Minimum Load Current	5mA @ 5VDC
Maximum Inrush Current	3A for 10ms
OFF to ON Response	< 15ms
ON to OFF Response	< 15ms
Status Indicators	Logic Side (6 points, red LED)
Commons	2 (4 points/com & 2 points/com) Isolated

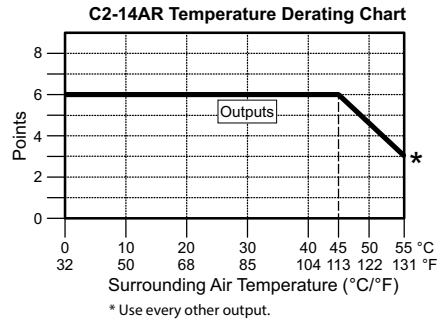

Typical Relay Life (Operations) at Room Temperature	
Voltage & Load Type	Relay Life
30VDC, 1A Resistive	200,000 cycles
30VDC, 1A Inductive	100,000 cycles
250VAC, 1A Resistive	200,000 cycles
250VAC, 1A Inductive	50,000 cycles
ON to OFF = 1 cycle	

Equivalent Output Circuit

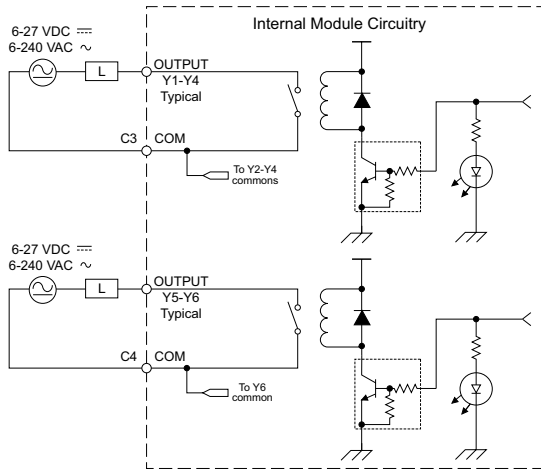

ZIPLink Pre-Wired PLC Connection Cables and Modules for CLICK PLC

- 20-pin connector cable
- ZL-C0-CBL20 (0.5 m length)
- ZL-C0-CBL20-1 (1.0 m length)
- ZL-C0-CBL20-2 (2.0 m length)



ZL-RTB20
20-pin feed-through connector module



NOTE: The C2-14AR is derated to 2A maximum per Common when used with the ZIPLink wiring system.

C2-14AR – 8 AC Input/6 Relay Output Option Slot I/O Module (continued)

Insulation Requirements for IEC/UL 61010-1 and 61010-2-201 (sections 6.5 and 6.7)

Input to Output Insulation

Basic insulation is provided between Relay Output 1 and the closest Input terminal. When connecting the Relay Output to a circuit that exceeds 100VAC (141VDC) more than the closest input circuit an additional basic insulation layer must be added to the input circuit.

Output to Output Insulation

Basic insulation is provided between Relay Outputs. When connecting a Relay Output to a circuit that exceeds 100VAC (141VDC) more than the adjacent Relay Outputs, an additional basic insulation layer must be added to the adjacent Relay Output circuits.

Additional Basic Insulation Examples

- Supplementary Insulation: Interposing relay, additional insulating material,... (sec. 6.5.3)
- Automatic Disconnection of the Supply: Properly sized breaker (sec. 6.5.5)
- Current or Voltage Limiting device: Properly sized fuse (sec. 6.5.6)

Basic insulation requires a clearance distance of 1.5 mm or more, a creepage distance of 2.5 mm or more, and dielectric voltage withstand of 1500Vrms.

AC input1 (X1-X4)	Internal circuit
AC input2 (X5-X8)	
Relay output1 (Y1-Y4)	
Relay output2 (Y5-Y6)	

————— : No insulation

----- : Basic insulation

————— : Reinforced insulation

C2-08D1-4VC – 4 DC Input (Sink/Source)/4 Sinking DC Output

2 Analog Voltage/Current Input

2 Analog Voltage/Current Output Option Slot I/O Module

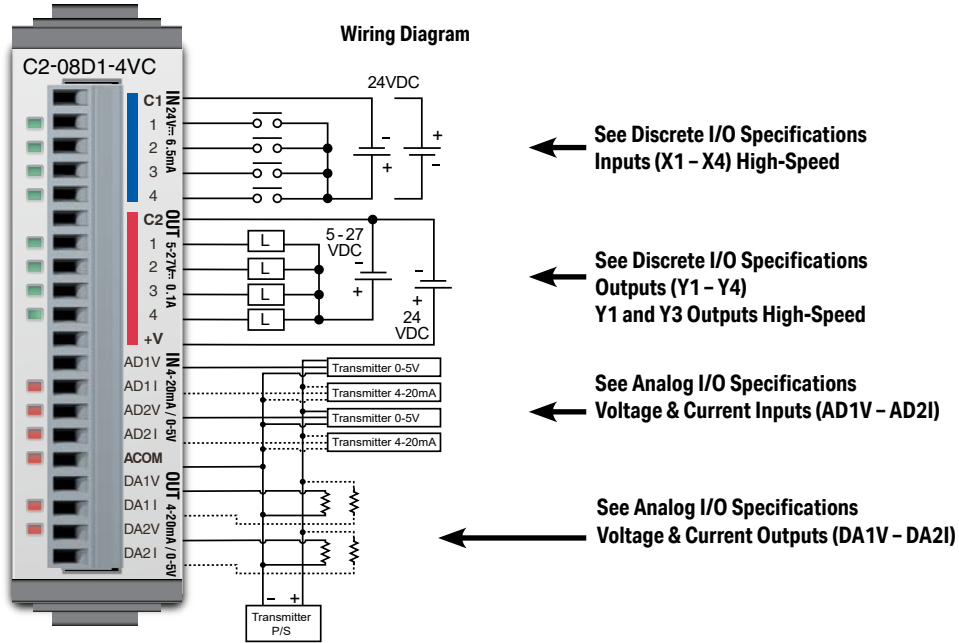

General Specifications	
Current Consumption at 24VDC	80mA max (All Points On)
Terminal Block Replacement Part No.	C0-16TB
Weight	48g

NOTE: Please refer to the Analog I/O Configuration section in Chapter 3 for information on using the analog I/O.

NOTE: There are no ZIPLink pre-wired PLC connection cables and modules for the Analog Option Slot Modules (cannot mix discrete I/O and analog I/O signals in a ZIPLink cable).



C2-08D1-4VC (continued)

X1 - X4

Discrete I/O Specifications - Inputs	
Inputs per Module	4 (Sink/Source)
Operating Voltage Range	24VDC
Input Voltage Range	21.6 - 26.4 VDC
Input Current	Typ 6.5 mA @ 24VDC
Maximum Input Current	7.0 mA @ 26.4 VDC
Input Impedance	3.9 kΩ @ 24VDC
Input Frequency (Max)	X1-X4: 100kHz (3m cable)
ON Voltage Level	> 19VDC
OFF Voltage Level	< 2VDC
Minimum ON Current	4.5 mA
Maximum OFF Current	0.5 mA
OFF to ON Response	Typ 3μs Max 5μs
ON to OFF Response	Typ 1μs Max 3μs
Status Indicators	Logic Side (4 points, green LED)
Commons	1 (4 points/common)

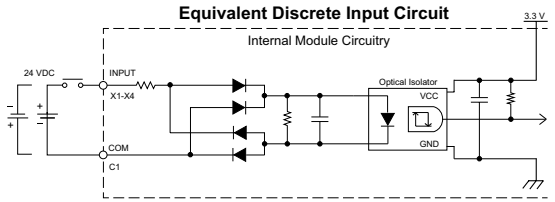

C2-08D1-4VC Temperature Derating Chart

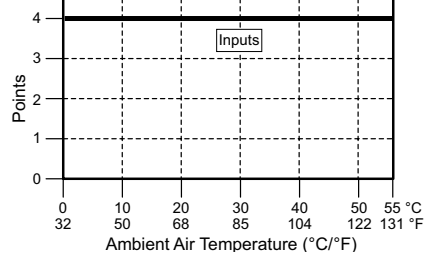

Maximum Number of High Speed Counters	
Up	4
Down	4
Up/Down	2
Pulse/Direction	2
Quadrature A-B	2
Quadrature A-B+Z	1

Y1 - Y4

Discrete I/O Specifications - Outputs	
Outputs per Module	4 (Sink)
Operating Voltage Range	5-27 VDC
Maximum Output Current	0.1 A/point; 0.4 A/common
Minimum Output Current	0.2 mA
Maximum Leakage Current	0.1 mA @ 30.0 VDC
On Voltage Drop	0.5 VDC @ 0.1 A
Maximum Inrush Current	150mA for 10ms
Output Frequency (Max)	Y1, Y3: 100kHz (3m cable)
OFF to ON Response	< 5μs (Duty 40-60%, Load current 20mA)
ON to OFF Response	< 5μs (Duty 40-60%, Load current 20mA)
Status Indicators	Logic Side (4 points, red LED)
Commons	1 (4 points/common)
External DC Power Required	20-28 VDC Maximum @ 60mA (All points ON)

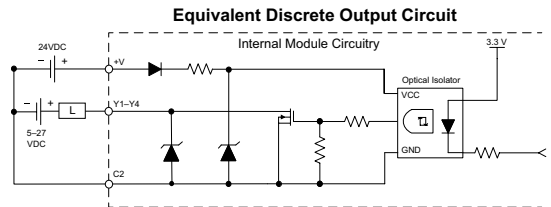

C2-08D1-4VC Temperature Derating Chart

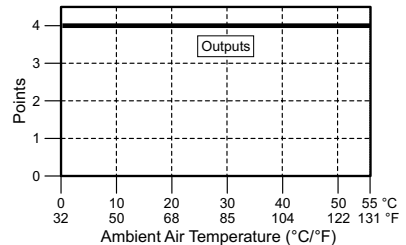

Maximum Number of High Speed Outputs	
Pulse Train	2
Pulse Width Modulation	2

C2-08D1-4VC (continued)

AD1V - AD2I

Analog Specifications - Voltage Input	
Inputs per Module	2 (voltage/current selectable)
Input Range	0-5 VDC (6VDC Max.)
Resolution	12-bit
Conversion Time	50ms
Input Impedance	20kΩ
Input Stability	±2 LSB maximum
Full-Scale Calibration Error	±2% maximum
Offset Calibration Error	±25mV maximum
Accuracy vs. Temperature Error	±100ppm/°C maximum

Analog Specifications - Current Input	
Inputs per Module	2 (voltage/current selectable)
Input Range	4-20 mA (sink)
Resolution	12-bit
Conversion Time	50ms
Input Impedance	125Ω
Input Stability	±2 LSB maximum
Full-Scale Calibration Error	±2% maximum
Offset Calibration Error	±0.1 mA maximum
Accuracy vs. Temperature Error	±100ppm/°C maximum

Analog Voltage Input Circuit

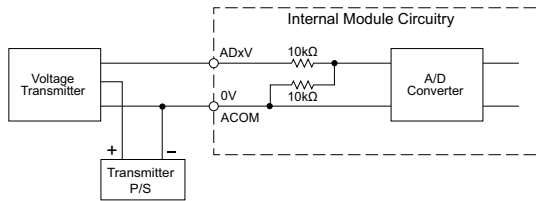

Analog Current Input Circuit

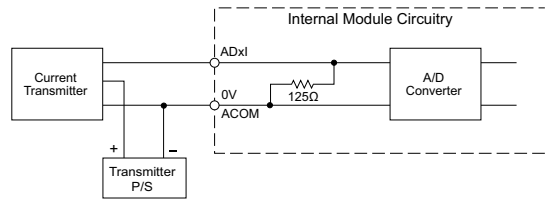

DA1V - DA2I

Analog Specifications - Voltage Output	
Outputs per Module	2 (voltage/current selectable)
Output Range	0-5 VDC
Resolution	12-bit
Conversion Time	1ms
Load Impedance	2kΩ minimum (output current 2.5 mA maximum)
Full-Scale Calibration Error	±2% maximum
Offset Calibration Error	±25mV maximum
Accuracy vs. Temperature Error	±100ppm/°C maximum

Analog Specifications - Current Output	
Outputs per Module	2 (voltage/current selectable)
Output Range	4-20 mA (sink)
Resolution	12-bit
Conversion Time	1ms
Loop Supply Voltage	DC 18-30 V
Load Impedance	250Ω Load Power Supply: DC 18V: 600Ω maximum DC 24V: 900Ω maximum DC 30V: 1200Ω maximum
Full-Scale Calibration Error	±2% maximum
Offset Calibration Error	±25mA maximum
Accuracy vs. Temperature Error	±100ppm/°C maximum

Analog Voltage Output Circuit

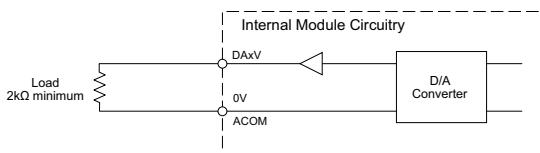

Analog Current Output Circuit

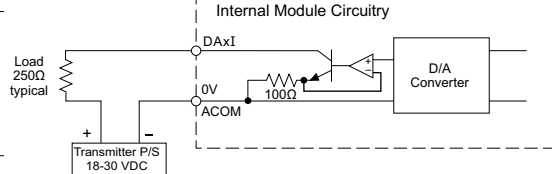

C2-08D2-4VC – 4 DC Input (Sink/Source)/4 Sourcing DC Output

2 Analog Voltage/Current Input

2 Analog Voltage/Current Output Option Slot I/O Module

Wiring Diagram

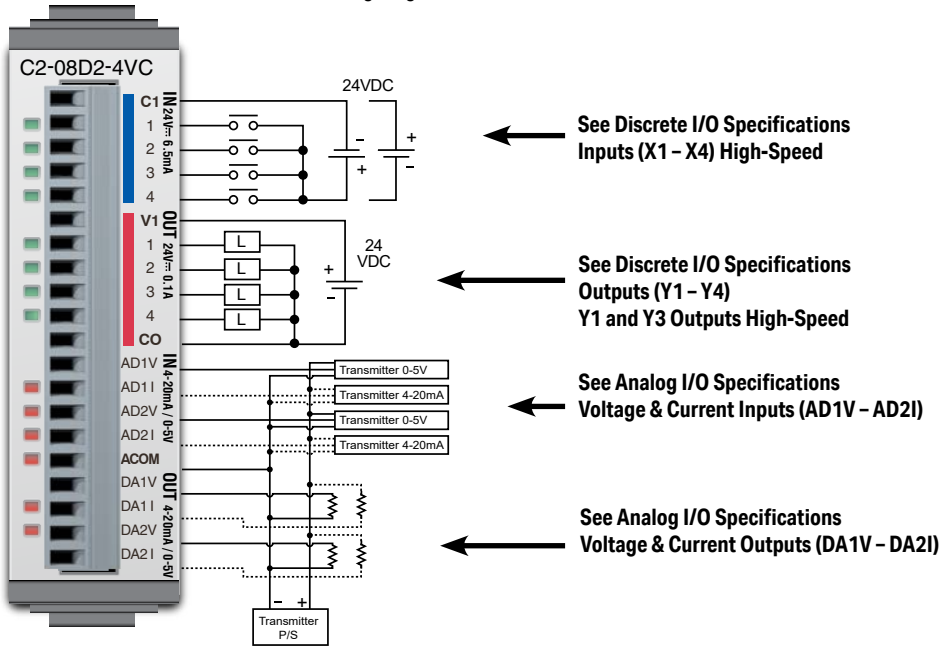

General Specifications	
Current Consumption at 24VDC	80mA max (All Points On)
Terminal Block Replacement Part No.	CO-16TB
Weight	48g

NOTE: Please refer to the Analog I/O Configuration section in Chapter 3 for information on using the analog I/O.



NOTE: There are no ZIPLink pre-wired PLC connection cables and modules for the Analog Option Slot Modules (cannot mix discrete I/O and analog I/O signals in a ZIPLink cable).

C2-08D2-4VC (continued)

X1 - X4

Discrete I/O Specifications - Inputs	
Inputs per Module	4 (Sink/Source)
Operating Voltage Range	24VDC
Input Voltage Range	21.6 - 26.4 VDC
Input Current	Typ 6.5 mA @ 24VDC
Maximum Input Current	7mA @ 26.4 VDC
Input Impedance	3.9 kΩ @ 24VDC
Input Frequency (Max)	X1-X4: 100kHz (3m cable)
ON Voltage Level	> 19VDC
OFF Voltage Level	< 2VDC
Minimum ON Current	4.5 mA
Maximum OFF Current	0.5 mA
OFF to ON Response	Typ 3μs, Max 5μs
ON to OFF Response	Typ 1μs, Max 3μs
Status Indicators	Logic Side (4 points, green LED)
Commons	1 (4 points/common)

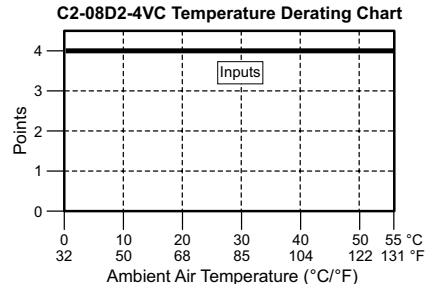
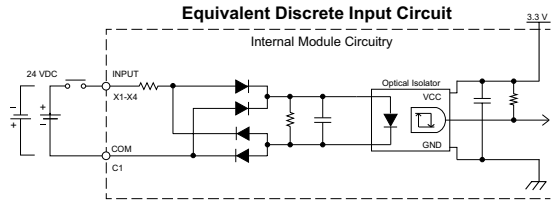

Maximum Number of High Speed Counters	
Up	4
Down	4
Up/Down	2
Pulse/Direction	2
Quadrature A-B	2
Quadrature A-B+Z	1

Y1 - Y4

Discrete I/O Specifications - Outputs	
Outputs per Module	4 (Source)
Operating Voltage Range	24VDC
Output Voltage Range	19.2-30 VDC
Maximum Output Current	0.1 A/point, 0.4 A/common
Minimum Output Current	0.2 mA
Maximum Leakage Current	0.1mA @ 30VDC
On Voltage Drop	0.5 VDC @ 0.1 A
Maximum Inrush Current	150mA for 10ms
Output Frequency (Max)	Y1, Y3: 100kHz (3m cable)
OFF to ON Response	< 5μs (Duty 40-60%, Load current 20mA)
ON to OFF Response	< 5μs (Duty 40-60%, Load current 20mA)
Status Indicators	Logic Side (4 points, red LED)
Commons	1 (4 points/common)

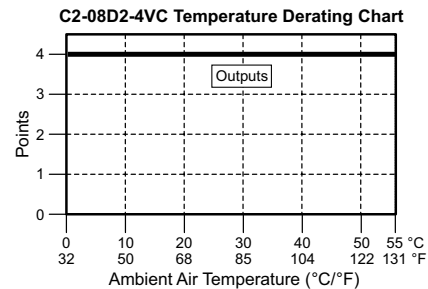
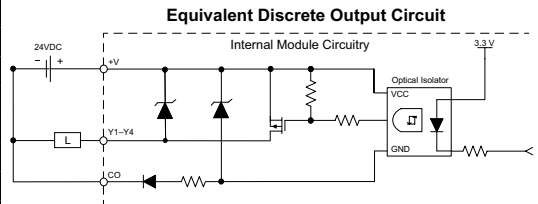

Maximum Number of High Speed Outputs	
Pulse Train	2
Pulse Width Modulation	2

C2-08D2-4VC (continued)

AD1V - AD2I

Analog Specifications - Voltage Input	
Inputs per Module	2 (voltage/current selectable)
Input Range	0-5 VDC
Resolution	12-bit
Conversion Time	50ms
Input Impedance	20k Ω
Input Stability	± 2 LSB maximum
Full-Scale Calibration Error	$\pm 2\%$ maximum
Offset Calibration Error	± 25 mV maximum
Accuracy vs. Temperature Error	± 100 ppm/ $^{\circ}$ C maximum

Analog Voltage Input Circuit

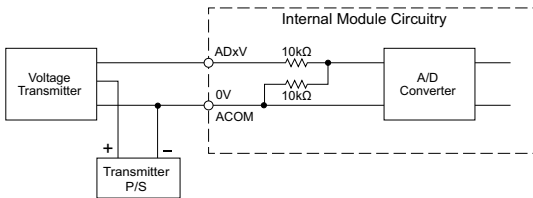

Analog Specifications - Current Input	
Inputs per Module	2 (voltage/current selectable)
Input Range	4-20 mA (sink)
Resolution	12-bit
Conversion Time	50ms
Input Impedance	125 Ω
Input Stability	± 2 LSB maximum
Full-Scale Calibration Error	$\pm 2\%$ maximum
Offset Calibration Error	± 0.1 mA maximum
Accuracy vs. Temperature Error	Less than ± 100 ppm/ $^{\circ}$ C

Analog Current Input Circuit

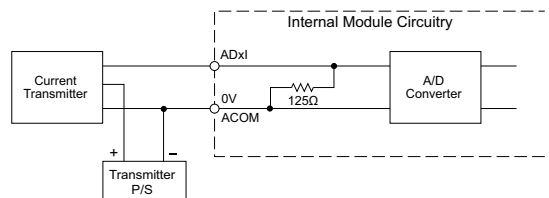

DA1V - DA2I

Analog Specifications - Voltage Output	
Outputs per Module	2 (voltage/current selectable)
Output Range	0-5 VDC
Resolution	12-bit
Conversion Time	1ms
Load Impedance	2k Ω minimum (output current 2.5 mA maximum)
Full-Scale Calibration Error	$\pm 2\%$ maximum
Offset Calibration Error	± 25 mV maximum
Accuracy vs. Temperature Error	± 100 ppm/ $^{\circ}$ C maximum

Analog Voltage Output Circuit

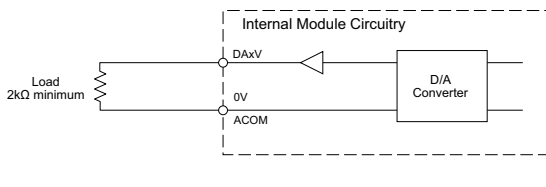

Analog Specifications - Current Output	
Outputs per Module	2 (voltage/current selectable)
Output Range	4-20 mA (sink)
Resolution	12-bit
Conversion Time	1ms
Loop Supply Voltage	DC 18-30 V
Load Impedance	250 Ω Load Power Supply: DC 18V: 600 Ω maximum DC 24V: 900 Ω maximum DC 30V: 1200 Ω maximum
Full-Scale Calibration Error	$\pm 2\%$ maximum
Offset Calibration Error	± 25 mA maximum
Accuracy vs. Temperature Error	± 100 ppm/ $^{\circ}$ C maximum

Analog Current Output Circuit

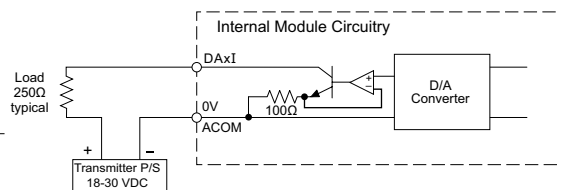

C2-08DR-4VC – 4 DC Input (Sink/Source)/4 Relay Output

2 Analog Voltage/Current Input

2 Analog Voltage/Current Output Option Slot I/O Module

Wiring Diagram

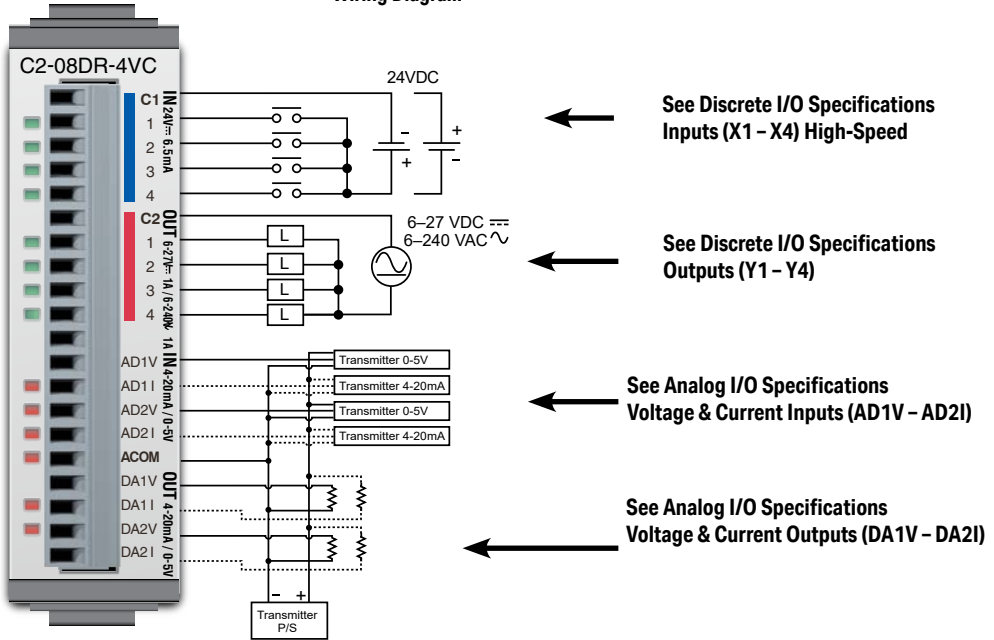

General Specifications	
Current Consumption at 24VDC	100mA max (All Points On)
Terminal Block Replacement Part No.	CO-16TB
Weight	58g

NOTE: Please refer to the Analog I/O Configuration section in Chapter 3 for information on using the analog I/O.



NOTE: There are no ZIPLink pre-wired PLC connection cables and modules for the Analog Option Slot Modules (cannot mix discrete I/O and analog I/O signals in a ZIPLink cable).

C2-08DR-4VC (continued)

X1 - X4

Discrete I/O Specifications - Inputs	
Inputs per Module	4 (Source/Sink)
Operating Voltage Range	24VDC
Input Voltage Range	21.6 – 26.4 VDC
Input Current	Typ 6.5 mA @ 24VDC
Input Impedance	3.9 kΩ @ 24 VDC
Input Frequency (Max)	X1-X4: 100kHz (3m cable)
ON Voltage Level	> 19VDC
OFF Voltage Level	< 2VDC
Minimum ON Current	4.5 mA
Maximum OFF Current	0.5 mA
OFF to ON Response	Typ 3μs, Max 5μs
ON to OFF Response	Typ 1μs, Max 3μs
Status Indicators	Logic Side (4 points, green LED)
Commons	1 (4 points/common)

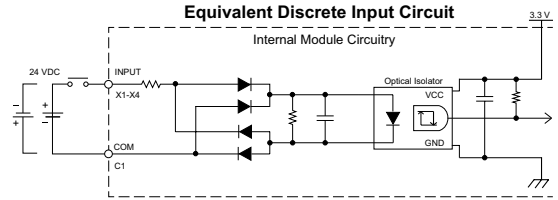

Maximum Number of High Speed Counters	
Up	4
Down	4
Up/Down	2
Pulse/Direction	2
Quadrature A-B	2
Quadrature A-B+Z	1

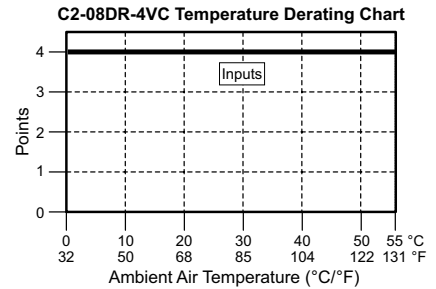

Y1 - Y4

Discrete I/O Specifications - Outputs	
Outputs per Module	4
Operating Voltage Range	6–27 VDC / 6–240 VAC
Output Type	Relay, form A (SPST)
AC Frequency	47–63 Hz
Maximum Current	1A/point (resistive)
Minimum Load Current	5mA @ 5VDC
Maximum Inrush Current	3A for 10ms
OFF to ON Response	< 15ms
ON to OFF Response	< 15ms
Status Indicators	Logic Side (4 points, red LED)
Commons per Module	1 (4 points/common)

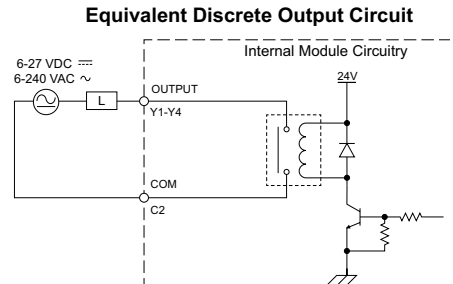

Typical Relay Life (Operations) at Room Temperature	
Voltage & Load Type	Relay Life
30VDC, 1A Resistive	200,000 cycles
30VDC, 1A Inductive	100,000 cycles
250VAC, 1A Resistive	200,000 cycles
250VAC, 1A Inductive	50,000 cycles
ON to OFF = 1 cycle	

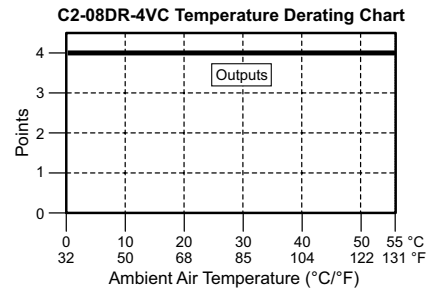

Chapter 2: Specifications

C2-08DR-4VC (continued)

AD1V - AD2I

Analog Specifications - Voltage Input	
Inputs per Module	2 (voltage/current selectable)
Input Range	0-5 VDC (6VDC Max.)
Resolution	12-bit
Conversion Time	50ms
Input Impedance	20kΩ
Input Stability	±2 LSB maximum
Full-Scale Calibration Error	±2% maximum
Offset Calibration Error	±25mV maximum
Accuracy vs. Temperature Error	±100ppm/°C maximum

Analog Specifications - Current Input	
Inputs per Module	2 (voltage/current selectable)
Input Range	4-20 mA (sink)
Resolution	12-bit
Conversion Time	50ms
Input Impedance	125Ω
Input Stability	±2 LSB maximum
Full-Scale Calibration Error	±2% maximum
Offset Calibration Error	±0.1 mA maximum
Accuracy vs. Temperature Error	±100ppm/°C maximum

Analog Voltage Input Circuit

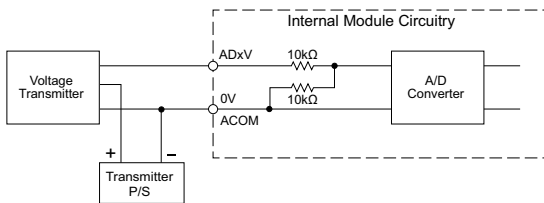

Analog Current Input Circuit

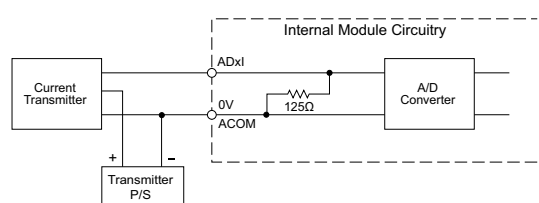

DA1V - DA2I

Analog Specifications - Voltage Output	
Outputs per Module	2 (voltage/current selectable)
Output Range	0-5 VDC
Resolution	12-bit
Conversion Time	1ms
Load Impedance	2kΩ minimum (output current 2.5 mA maximum)
Full-Scale Calibration Error	±2% maximum
Offset Calibration Error	±25mV maximum
Accuracy vs. Temperature Error	±100ppm/°C maximum

Analog Specifications - Current Output	
Outputs per Module	2 (voltage/current selectable)
Output Range	4-20 mA (sink)
Resolution	12-bit
Conversion Time	1ms
Loop Supply Voltage	DC 18-30 V
Load Impedance	250Ω Load Power Supply: DC 18V: 600Ω maximum DC 24V: 900Ω maximum DC 30V: 1200Ω maximum
Full-Scale Calibration Error	±2% maximum
Offset Calibration Error	±25mA maximum
Accuracy vs. Temperature Error	±100ppm/°C maximum

Analog Voltage Output Circuit

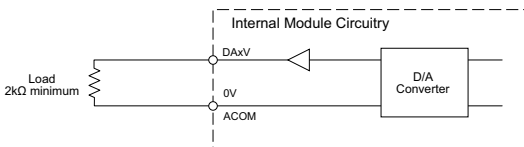

Analog Current Output Circuit

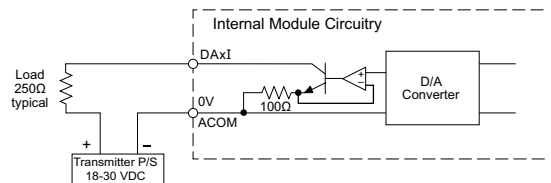

C2-08DR-4VC (continued)**Insulation Requirements for IEC/UL 61010-1 and 61010-2-201 (sections 6.5 and 6.7)****Input to Output Insulation**

Basic insulation is provided between the Relay Output and the closest Input terminal. When connecting the Relay Output to a circuit that exceeds 100VAC (141VDC) more than the closest input circuit an additional basic insulation layer must be added to the input circuit.

Additional Basic Insulation Examples

- Supplementary Insulation: Interposing relay, additional insulating material,... (sec. 6.5.3)
- Automatic Disconnection of the Supply: Properly sized breaker (sec. 6.5.5)
- Current or Voltage Limiting device: Properly sized fuse (sec. 6.5.6)

Basic insulation requires a clearance distance of 1.5 mm or more, a creepage distance of 2.5 mm or more, and dielectric voltage withstand of 1500Vrms.

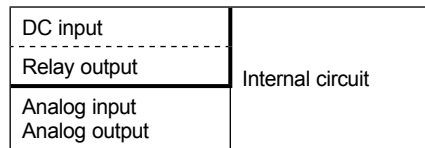

————— : No insulation

----- : Basic insulation

————— : Reinforced insulation

C2-08AR-4VC – 4 AC Input/4 Relay Output

2 Analog Voltage/Current Input

2 Analog Voltage/Current Output Option Slot I/O Module

Wiring Diagram

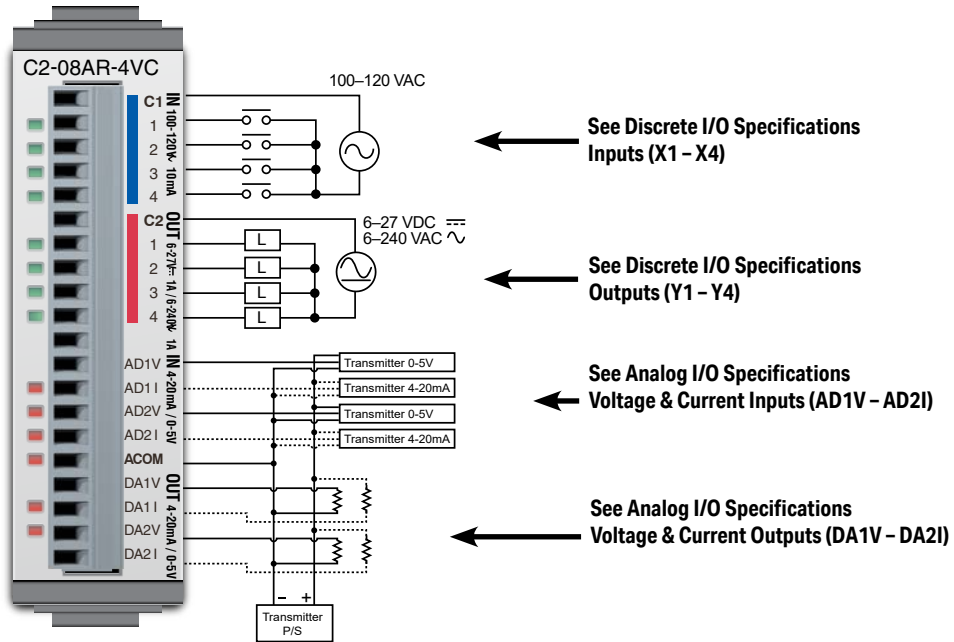

General Specifications	
Current Consumption at 24VDC	100mA max (All Points On)
Terminal Block Replacement Part No.	C0-16TB
Weight	58g

NOTE: Please refer to the Analog I/O Configuration section in Chapter 3 for information on using the analog I/O.



NOTE: There are no ZIPLink pre-wired PLC connection cables and modules for the Analog Option Slot Modules (cannot mix discrete I/O and analog I/O signals in a ZIPLink cable).

C2-08AR-4VC (continued)

X1 - X4

Discrete I/O Specifications - Inputs	
Inputs per Module	4
Operating Voltage Range	100-120 VAC
AC Frequency	47-63 Hz
Input Current	Typ 8.5 mA @ 100VAC (50Hz) Typ 10mA @100VAC (60Hz)
Max. Input Current	16mA @ 144VAC
Input Impedance	15kΩ @ 50Hz 12kΩ @ 60Hz
ON Voltage Level	> 60VAC
OFF Voltage Level	< 20VAC
Minimum ON Current	5mA
Maximum OFF Current	2mA
OFF to ON Response	< 40ms
ON to OFF Response	< 40ms
Status Indicators	Logic Side (4 points, green LED)
Commons	1 (4 points/common)

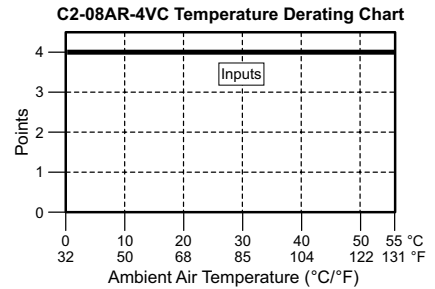
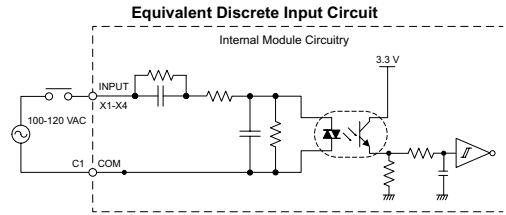

Y1 - Y4

Discrete I/O Specifications - Outputs	
Outputs per Module	4
Operating Voltage Range	6-27 VDC, 6-240 VAC
Output Type	Relay, form A (SPST)
AC Frequency	47-63 Hz
Maximum Current	1A/point (resistive)
Minimum Load Current	5mA @ 5VDC
Maximum Inrush Current	3A for 10ms
OFF to ON Response	< 15ms
ON to OFF Response	< 15ms
Status Indicators	Logic Side (4 points, red LED)
Commons per Module	1 (4 points/common)

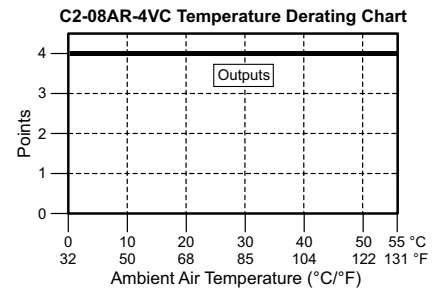
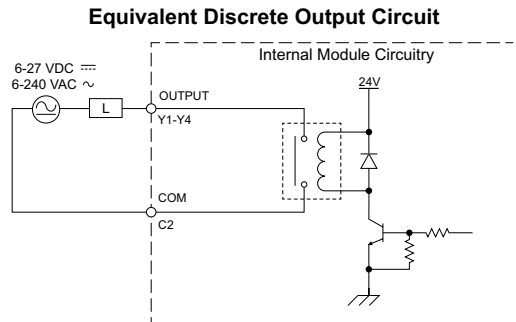

Typical Relay Life (Operations) at Room Temperature	
Voltage & Load Type	Relay Life
30VDC, 1A Resistive	200,000 cycles
30VDC, 1A Inductive	100,000 cycles
250VAC, 1A Resistive	200,000 cycles
250VAC, 1A Inductive	50,000 cycles
ON to OFF = 1 cycle	

C2-08AR-4VC (continued)

AD1V - AD2V

Analog Specifications - Voltage Input	
Inputs per Module	2 (voltage/current selectable)
Input Range	0-5 VDC (6VDC Max.)
Resolution	12-bit
Conversion Time	50ms
Input Impedance	20kΩ
Input Stability	±2 LSB maximum
Full-Scale Calibration Error	±2% maximum
Offset Calibration Error	±25mV maximum
Accuracy vs. Temperature Error	±100ppm/°C maximum

Analog Voltage Input Circuit

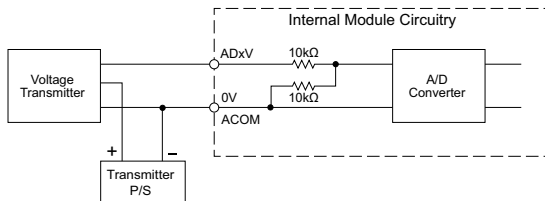

AD1I - AD2I

Analog Specifications - Current Input	
Inputs per Module	2 (voltage/current selectable)
Input Range	4-20 mA (sink)
Resolution	12-bit
Conversion Time	50ms
Input Impedance	125Ω
Input Stability	±2 LSB maximum
Full-Scale Calibration Error	±2% maximum
Offset Calibration Error	±0.1 mA maximum
Accuracy vs. Temperature Error	±100ppm/°C maximum

Analog Current Input Circuit

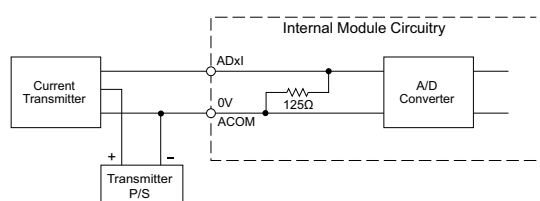

DA1V - DA2V

Analog Specifications - Voltage Output	
Outputs per Module	2 (voltage/current selectable)
Output Range	0-5 VDC
Resolution	12-bit
Conversion Time	1ms
Load Impedance	2kΩ minimum (output current 2.5 mA maximum)
Full-Scale Calibration Error	±2% maximum
Offset Calibration Error	±25mV maximum
Accuracy vs. Temperature Error	±100ppm/°C maximum

Analog Voltage Output Circuit

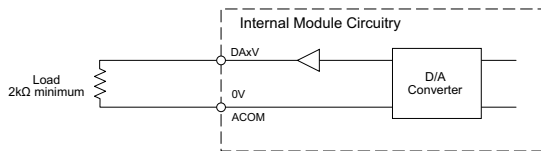

DA1I - DA2I

Analog Specifications - Current Output	
Outputs per Module	2 (voltage/current selectable)
Output Range	4-20 mA (sink)
Resolution	12-bit
Conversion Time	1ms
Loop Supply Voltage	DC 18-30 V
Load Impedance	250Ω Load Power Supply: DC 18V: 600Ω maximum DC 24V: 900Ω maximum DC 30V: 1200Ω maximum
Full-Scale Calibration Error	±2% maximum
Offset Calibration Error	±25mA maximum
Accuracy vs. Temperature Error	±100ppm/°C maximum

Analog Current Output Circuit

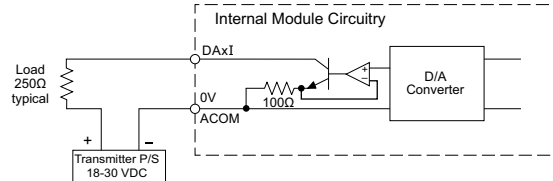

C2-08AR-4VC (continued)**Insulation Requirements for IEC/UL 61010-1 and 61010-2-201 (sections 6.5 and 6.7)****Input to Output Insulation**

Basic insulation is provided between the Relay Output and the closest Input terminal. When connecting the Relay Output to a circuit that exceeds 100VAC (141VDC) more than the closest input circuit an additional basic insulation layer must be added to the input circuit.

Additional Basic Insulation Examples

- Supplementary Insulation: Interposing relay, additional insulating material,... (sec. 6.5.3)
- Automatic Disconnection of the Supply: Properly sized breaker (sec. 6.5.5)
- Current or Voltage Limiting device: Properly sized fuse (sec. 6.5.6)

Basic insulation requires a clearance distance of 1.5 mm or more, a creepage distance of 2.5 mm or more, and dielectric voltage withstand of 1500Vrms.

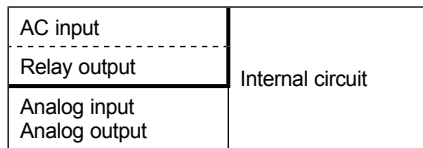

————— : No insulation

----- : Basic insulation

————— : Reinforced insulation

C2-08D1-6C – 4 DC Input (Sink/Source)/4 Sinking DC Output

4 Analog Current Input

2 Analog Current Output Option Slot I/O Module

Wiring Diagram

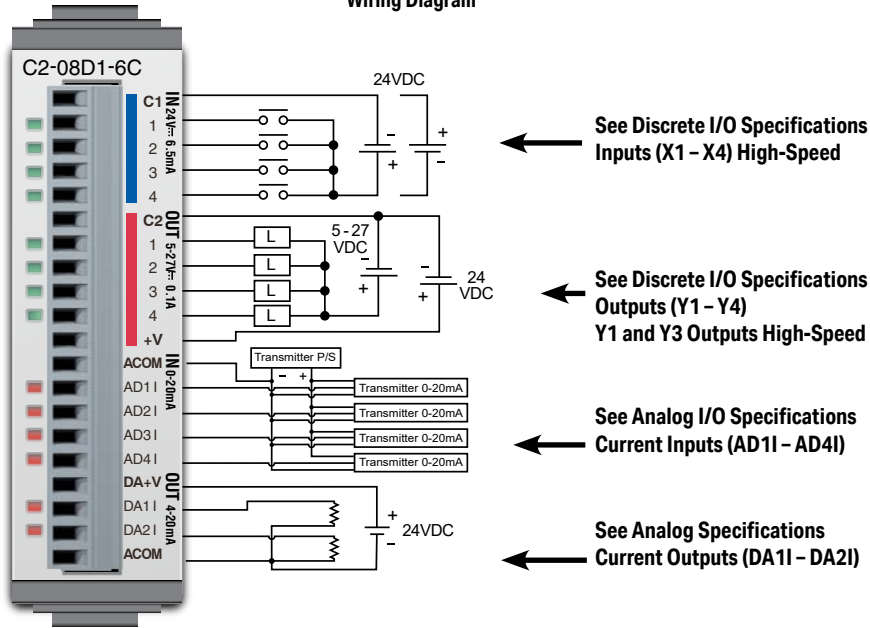

General Specifications	
Current Consumption at 24VDC	80mA max (All Points On)
Terminal Block Replacement Part No.	C0-16TB
Weight	48g

NOTE: Please refer to the Analog I/O Configuration section in Chapter 3 for information on using the analog I/O.



NOTE: There are no ZIPLink pre-wired PLC connection cables and modules for the Analog Option Slot Modules (cannot mix discrete I/O and analog I/O signals in a ZIPLink cable).

C2-08D1-6C (continued)

X1 - X4

Discrete I/O Specifications - Inputs	
Inputs per Module	4 (Sink/Source)
Operating Voltage Range	24VDC
Input Voltage Range	21.6 – 26.4 VDC
Input Current	Typ 6.5 mA @ 24VDC
Maximum Input Current	7mA @ 26.4 VDC
Input Impedance	3.9 kΩ @ 24VDC
Input Frequency (Max)	X1-X4: 100kHz (3m cable)
ON Voltage Level	>19VDC
OFF Voltage Level	< 2VDC
Minimum ON Current	4.5 mA
Maximum OFF Current	0.5 mA
OFF to ON Response	Typ 3μs Max 5μs
ON to OFF Response	Typ 1μs Max 3μs
Status Indicators	Logic Side (4 points, green LED)
Commons	1 (4 points/common)

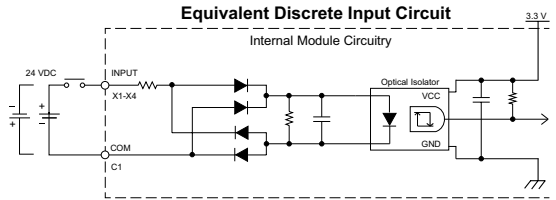

Maximum Number of High Speed Counters	
Up	4
Down	4
Up/Down	2
Pulse/Direction	2
Quadrature A-B	2
Quadrature A-B+Z	1

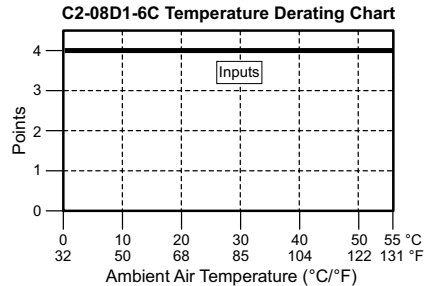

Y1 - Y4

Discrete I/O Specifications - Outputs	
Outputs per Module	4 (Sink)
Operating Voltage Range	5–27 VDC
Maximum Output Current	0.1 A/point; 0.4 A/common
Minimum Output Current	0.2 mA
Maximum Leakage Current	0.1 mA @ 30.0 VDC
On Voltage Drop	0.5 VDC @ 0.1 A
Maximum Inrush Current	150mA for 10ms
Output Frequency (Max)	Y1, Y3: 100kHz (3m cable)
OFF to ON Response	< 5μs (Duty 40–60%, Load current 20mA)
ON to OFF Response	< 5μs (Duty 40–60%, Load current 20mA)
Status Indicators	Logic Side (4 points, red LED)
Commons	1 (4 points/common)
External DC Power Required	20–28 VDC Maximum @ 60mA (All points on)

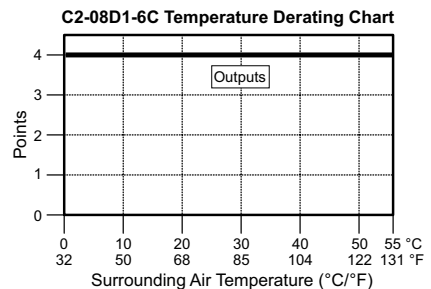
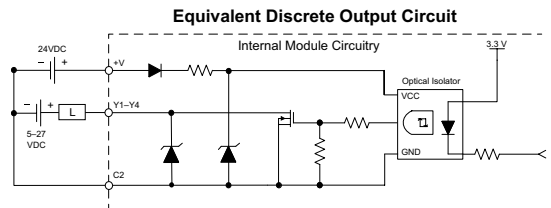

Maximum Number of High Speed Outputs	
Pulse Train	2
Pulse Width Modulation	2

AD1I - AD4I

Analog Specifications - Current Input	
Inputs per Module	4 (current)
Input Range	0–20 mA (sink)
Resolution	12-bit
Conversion Time	50ms
Input Impedance	125Ω
Input Stability	±2 LSB maximum
Full-Scale Calibration Error	±2% maximum
Offset Calibration Error	±0.1 mA maximum
Accuracy vs. Temperature Error	±120ppm/°C maximum

Analog Current Input Circuit

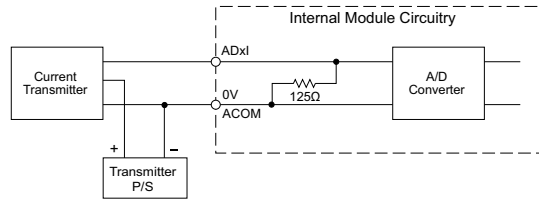

DA1I - DA2I

Analog Specifications - Current Output	
Outputs per Module	2 (current)
Output Range	4–20 mA (source)
Resolution	12-bit
Conversion Time	2.5 ms
Load Impedance	250Ω TYP (200–800 Ω)
Loop Supply Voltage	DC 24V TYP (21.6 – 26.4 VDC)
Full-Scale Calibration Error	±2% maximum
Offset Calibration Error	±25mA maximum
Accuracy vs. Temperature Error	±120ppm/°C maximum
External DC Power Required	21.6 – 26.4 VDC

Analog Current Output Circuit

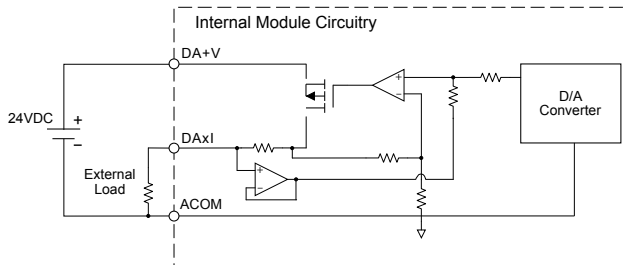

C2-08D2-6C – 4 DC Input (Sink/Source)/4 Sourcing DC Output

4 Analog Current Input

2 Analog Current Output Option Slot I/O Module

Wiring Diagram

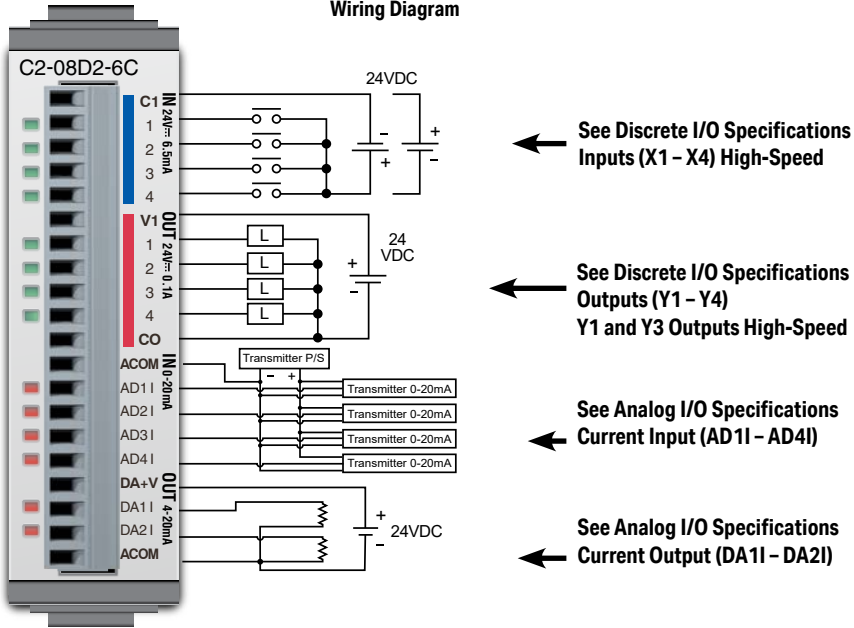

General Specifications	
Current Consumption at 24VDC	80mA max (All Points On)
Terminal Block Replacement Part No.	C0-16TB
Weight	48g

NOTE: Please refer to the Analog I/O Configuration section in Chapter 3 for information on using the analog I/O.

NOTE: There are no ZIPLink pre-wired PLC connection cables and modules for the Analog Option Slot Modules (cannot mix discrete I/O and analog I/O signals in a ZIPLink cable).



C2-08D2-6C (continued)

X1 - X4

Discrete I/O Specifications - Inputs	
Inputs per Module	4 (Sink/Source)
Operating Voltage Range	24VDC
Input Voltage Range	21.6 – 26.4 VDC
Input Current	Typ 6.5 mA @ 24VDC
Maximum Input Current	7mA @ 26.4 VDC
Input Impedance	3.9 kΩ @ 24VDC
Input Frequency (Max)	X1-X4: 100kHz (3m cable)
ON Voltage Level	>19VDC
OFF Voltage Level	< 2VDC
Minimum ON Current	4.5 mA
Maximum OFF Current	0.5 mA
OFF to ON Response	Typ 3μs Max 5μs
ON to OFF Response	Typ 1μs Max 3μs
Status Indicators	Logic Side (4 points, green LED)
Commons	1 (4 points/common)

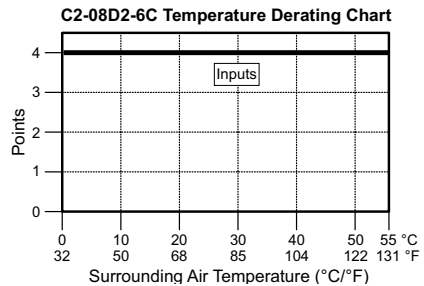
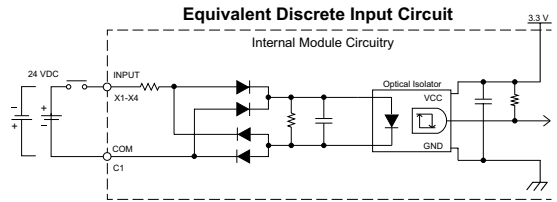

Maximum Number of High Speed Counters	
Up	4
Down	4
Up/Down	2
Pulse/Direction	2
Quadrature A-B	2
Quadrature A-B+Z	1

Y1 - Y4

Discrete I/O Specifications - Outputs	
Outputs per Module	4 (Source)
Operating Voltage Range	19.2–30 VDC
Maximum Output Current	0.1 A/point; 0.4 A/common C0
Minimum Output Current	0.2 mA
Maximum Leakage Current	0.1 mA @ 30.0 VDC
On Voltage Drop	0.5 VDC @ 0.1 A
Maximum Inrush Current	150mA for 10ms
Output Frequency (Max)	Y1, Y3: 100kHz (3m cable)
OFF to ON Response	< 5μs (Duty 40–60%, Load current 20mA)
ON to OFF Response	< 5μs (Duty 40–60%, Load current 20mA)
Status Indicators	Logic side (4 points, red LED)
Commons	1 (4 points/common)

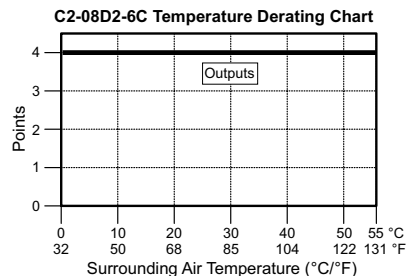
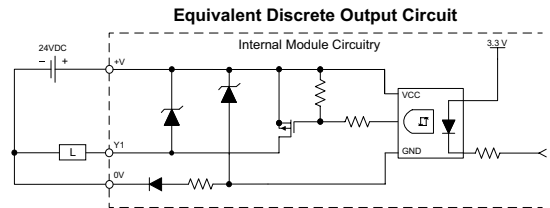

Maximum Number of High Speed Outputs	
Pulse Train	2
Pulse Width Modulation	2

C2-08D2-6C (continued)

AD1I - AD4I

Analog Specifications - Current Input	
Inputs per Module	4 (current)
Input Range	0–20 mA (sink)
Resolution	12-bit
Conversion Time	50ms
Input Impedance	125Ω
Input Stability	±2 LSB maximum
Full-Scale Calibration Error	±2% maximum
Offset Calibration Error	±0.1 mA maximum
Accuracy vs. Temperature Error	±100ppm/°C maximum

Analog Current Input Circuit

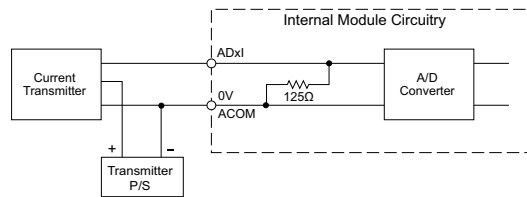

DA1I - DA2I

Analog Specifications - Current Output	
Outputs per Module	2 (current)
Output Range	4–20 mA (source)
Resolution	12-bit
Conversion Time	2.5 ms
Load Impedance	250Ω Typ (200Ω to 800Ω)
Loop Supply Voltage	24VDC Typ (21.6 – 26.4 VDC)
Full-Scale Calibration Error	±2% maximum
Offset Calibration Error	±25mA maximum
Accuracy vs. Temperature Error	±120ppm/°C maximum
External DC Power Required	21.6 – 26.4 VDC

Analog Current Output Circuit

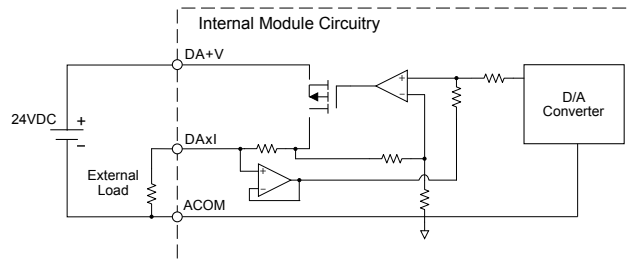

C2-08DR-6C – 4 DC Input (Sink/Source)/4 Relay Output

4 Analog Current Input

2 Analog Current Output Option Slot I/O Module

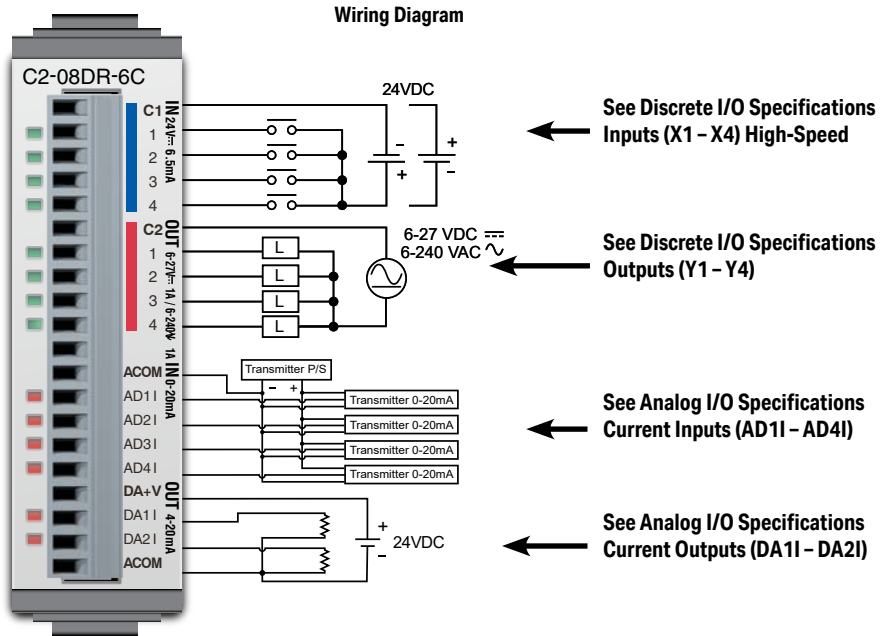

General Specifications	
Current Consumption at 24VDC	100mA max (All Points On)
Terminal Block Replacement Part No.	CO-16TB
Weight	58g

NOTE: Please refer to the Analog I/O Configuration section in Chapter 3 for information on using the analog I/O.



NOTE: There are no ZIPLink pre-wired PLC connection cables and modules for the Analog Option Slot Modules (cannot mix discrete I/O and analog I/O signals in a ZIPLink cable).

C2-08DR-6C (continued)

X1 - X4

Discrete I/O Specifications - Inputs	
Inputs per Module	4
Operating Voltage Range	24VDC
Input Voltage Range	21.6 – 26.4 VDC
Input Current	Typ 6.5 mA @ 24VDC
Max. Input Current	7mA @ 26.4 VDC
Input Impedance	3.9 kΩ @ 24VDC
Input Frequency (Max)	X1-X4: 100kHz (3m cable)
ON Voltage Level	>19VDC
OFF Voltage Level	< 2VDC
Minimum ON Current	4.5 mA
Maximum OFF Current	0.5 mA
OFF to ON Response	Typ 3μs Max 5μs
ON to OFF Response	Typ 1μs Max 3μs
Status Indicators	Logic Side (4 points, green LED)
Commons	1 (4 points/common)

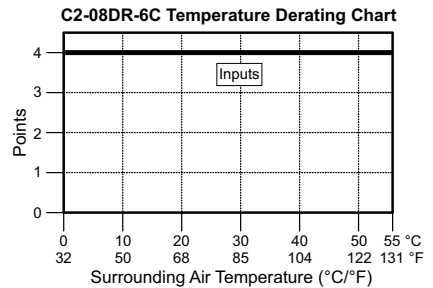
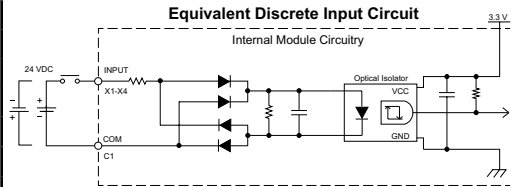

Maximum Number of High Speed Counters	
Up	4
Down	4
Up/Down	2
Pulse/Direction	2
Quadrature A-B	2
Quadrature A-B+Z	1

Equivalent Discrete Output Circuit

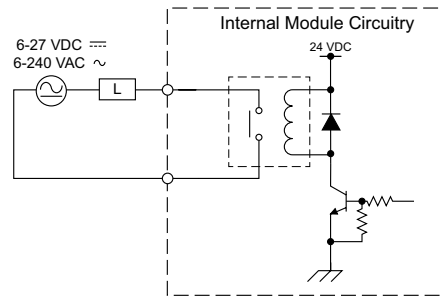

Y1 - Y4

Discrete I/O Specifications - Outputs	
Outputs per Module	4
Operating Voltage Range	6-27 VDC, 6-240 VAC
Output Type	Relay, form A (SPST)
AC Frequency	47-63 Hz
Maximum Current	1A/point (resistive)
Minimum Load Current	5mA @ 5VDC
Maximum Inrush Current	3A for 10ms
OFF to ON Response	< 15ms
ON to OFF Response	< 15ms
Status Indicators	Logic Side (4 points, red LED)
Commons	1 (4 points/common)

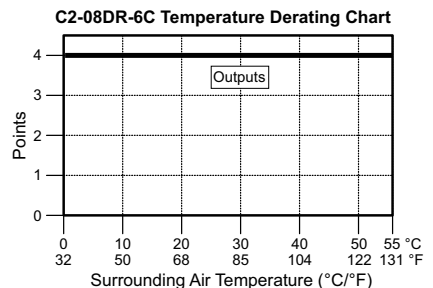

Typical Relay Life (Operations) at Room Temperature	
Voltage & Load Type	Relay Life
30VDC, 1A Resistive	200,000 cycles
30VDC, 1A Inductive	100,000 cycles
250VAC, 1A Resistive	200,000 cycles
250VAC, 1A Inductive	50,000 cycles

ON to OFF = 1 cycle

AD1I - AD4I

Analog Specifications - Current Input	
Inputs per Module	4 (Current)
Input Range	0–20 mA (Sink)
Resolution	12-bit
Conversion Time	50ms
Input Impedance	125Ω
Input Stability	±2 LSB maximum
Full-Scale Calibration Error	±2% maximum
Offset Calibration Error	±0.1 mA maximum
Accuracy vs. Temperature Error	±100ppm/°C maximum

Analog Current Input Circuit

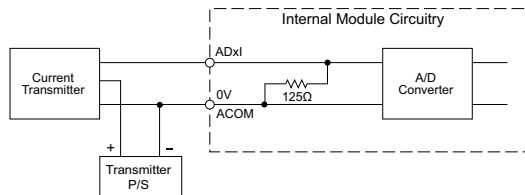

DA1I - DA2I

Analog Specifications - Current Output	
Outputs per Module	2 (Current)
Output Range	4–20 mA (Source)
Resolution	12-bit
Conversion Time	2.5 ms
Load Impedance	250Ω Typ (200Ω to 800Ω)
Loop Supply Voltage	24VDC Typ (21.6–26.4)
Full-Scale Calibration Error	±2% maximum
Offset Calibration Error	±25mA maximum
Accuracy vs. Temperature Error	±120ppm/°C maximum
External DC Power Required	21.6 – 26.4 VDC

Analog Current Output Circuit

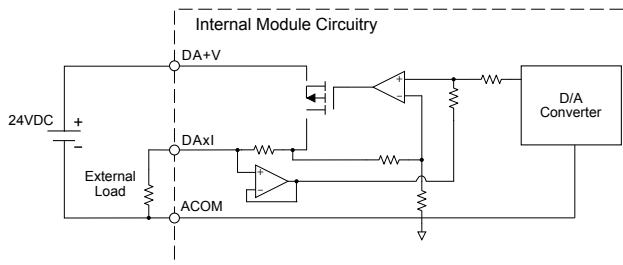

C2-08DR-6C (continued)

Insulation Requirements for IEC/UL 61010-1 and 61010-2-201 (sections 6.5 and 6.7)**Input to Output Insulation**

Basic insulation is provided between the Relay Output and the closest Input terminal. When connecting the Relay Output to a circuit that exceeds 100VAC (141VDC) more than the closest input circuit an additional basic insulation layer must be added to the input circuit.

Additional Basic Insulation Examples

- Supplementary Insulation: Interposing relay, additional insulating material,... (sec. 6.5.3)
- Automatic Disconnection of the Supply: Properly sized breaker (sec. 6.5.5)
- Current or Voltage Limiting device: Properly sized fuse (sec. 6.5.6)

Basic insulation requires a clearance distance of 1.5 mm or more, a creepage distance of 2.5 mm or more, and dielectric voltage withstand of 1500Vrms.

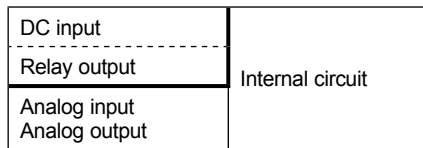

—————: No insulation

-----: Basic insulation

—————: Reinforced insulation

C2-08AR-6C – 4 AC Input/4 Relay Output

4 Analog Current Input

2 Analog Current Output Option Slot I/O Module

Wiring Diagram

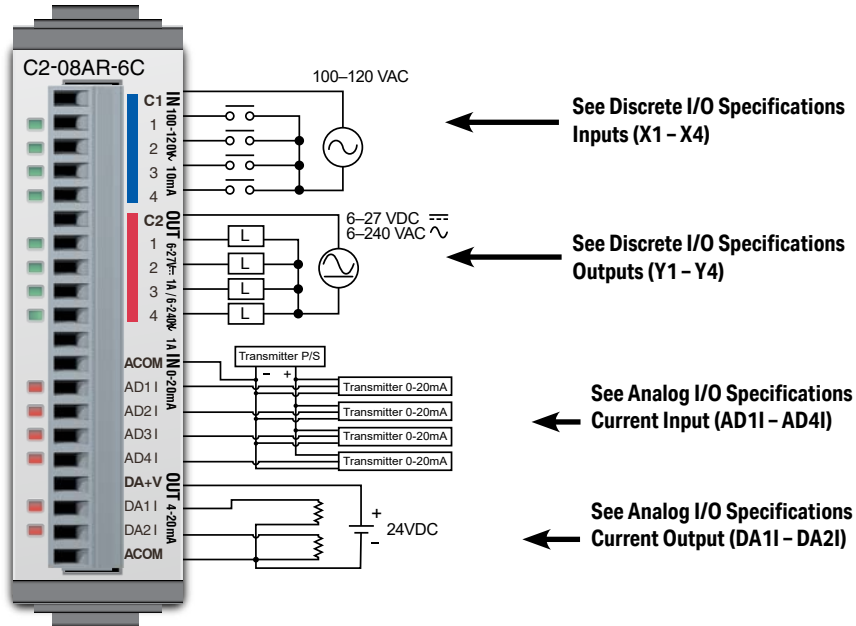

General Specifications	
Current Consumption at 24VDC	100mA max (All Points On)
Terminal Block Replacement Part No.	C0-16TB
Weight	58g

NOTE: Please refer to the Analog I/O Configuration section in Chapter 3 for information on using the analog I/O.

NOTE: There are no ZIPLink pre-wired PLC connection cables and modules for the Analog Option Slot Modules (cannot mix discrete I/O and analog I/O signals in a ZIPLink cable).

C2-08AR-6C (continued)

X1 - X4

Discrete I/O Specifications - Inputs	
Inputs per Module	4
Operating Voltage Range	100-120 VAC
AC Frequency	47-63 Hz
Input Current	Typ 8.5 mA @ 100VAC at 50Hz Typ 10mA @ 100VAC at 60Hz
Maximum Input Current	16mA @ 144VAC
Input Impedance	15kΩ @ 50Hz 12kΩ @ 60Hz
ON Voltage Level	> 60VAC
OFF Voltage Level	< 20VAC
Minimum ON Current	5mA
Maximum OFF Current	2mA
OFF to ON Response	< 40ms
ON to OFF Response	< 40ms
Status Indicators	Logic Side (4 points, green LED)
Commons	1 (4 points/common)

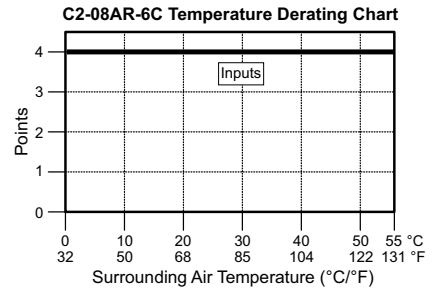
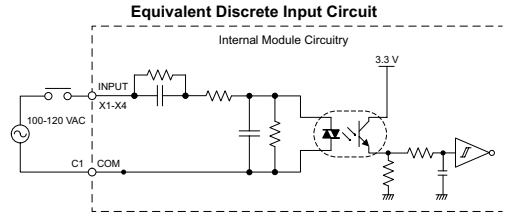

Y1 - Y4

Discrete I/O Specifications - Outputs	
Outputs per Module	4
Operating Voltage Range	6-27 VDC, 6-240 VAC
Output Type	Relay, form A (SPST)
AC Frequency	47-63 Hz
Maximum Current	1A/point (resistive)
Minimum Load Current	5mA @ 5VDC
Maximum Inrush Current	3A for 10ms
OFF to ON Response	< 15ms
ON to OFF Response	< 15ms
Status Indicators	Logic Side (4 points, red LED)
Commons per Module	1 (4 points/common)

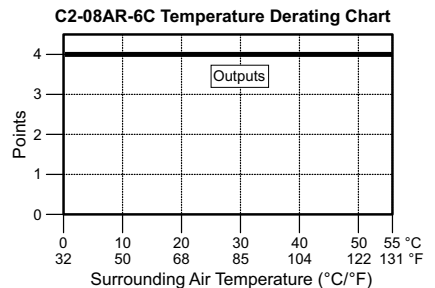
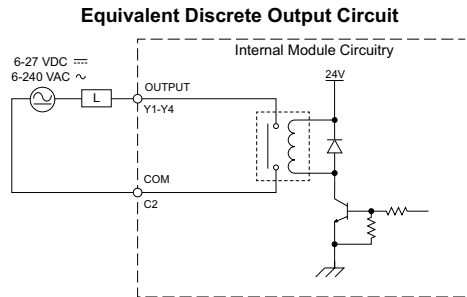

Typical Relay Life (Operations) at Room Temperature	
Voltage & Load Type	Relay Life
30VDC, 1A Resistive	200,000 cycles
30VDC, 1A Inductive	100,000 cycles
250VAC, 1A Resistive	200,000 cycles
250VAC, 1A Inductive	50,000 cycles

ON to OFF = 1 cycle

C2-08AR-6C (continued)

AD1I – AD4I

Analog Specifications - Current Input	
Inputs per Module	4 (current)
Input Range	0–20 mA (sink)
Resolution	12-bit
Conversion Time	50ms
Input Impedance	125Ω
Input Stability	±2 LSB maximum
Full-Scale Calibration Error	±2% maximum
Offset Calibration Error	±0.1 mA maximum
Accuracy vs. Temperature Error	±100ppm/°C maximum

Analog Current Input Circuit

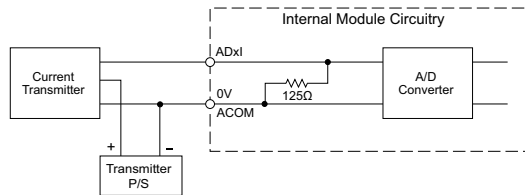

DA1I – DA2I

Analog Specifications - Current Output	
Outputs per Module	2 (current)
Output Range	4–20 mA (source)
Resolution	12-bit
Conversion Time	2.5 ms
Load Impedance	250Ω Typ (200Ω to 800Ω)
Loop Supply Voltage	DC 24V Typ (21.6 – 26.4 V)
Full-Scale Calibration Error	±2% maximum
Offset Calibration Error	±25mA maximum
Accuracy vs. Temperature Error	±120ppm/°C maximum
External DC Power Supply Required	21.6–26.4 VDC

Analog Current Output Circuit

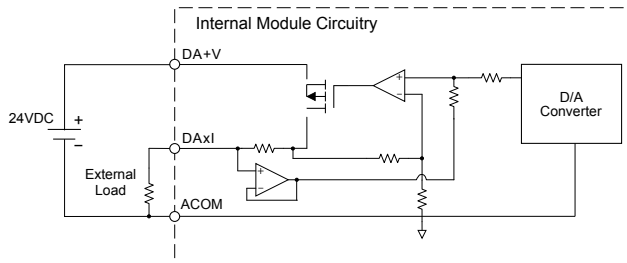

C2-08AR-6C (continued)

Insulation Requirements for IEC/UL 61010-1 and 61010-2-201 (sections 6.5 and 6.7)

Input to Output Insulation

Basic insulation is provided between the Relay Output and the closest Input terminal. When connecting the Relay Output to a circuit that exceeds 100VAC (141VDC) more than the closest input circuit an additional basic insulation layer must be added to the input circuit.

Additional Basic Insulation Examples

- Supplementary Insulation: Interposing relay, additional insulating material,... (sec. 6.5.3)
- Automatic Disconnection of the Supply: Properly sized breaker (sec. 6.5.5)
- Current or Voltage Limiting device: Properly sized fuse (sec. 6.5.6)

Basic insulation requires a clearance distance of 1.5 mm or more, a creepage distance of 2.5 mm or more, and dielectric voltage withstand of 1500Vrms.

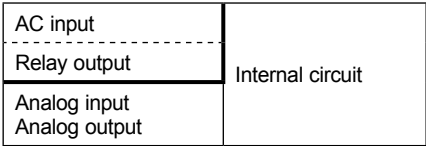

- : No insulation
- : Basic insulation
- : Reinforced insulation

C2-08D1-6V – 4 DC Input (Sink/Source)/4 Sinking DC Output

4 Analog Voltage Input

2 Analog Voltage Output Option Slot I/O Module

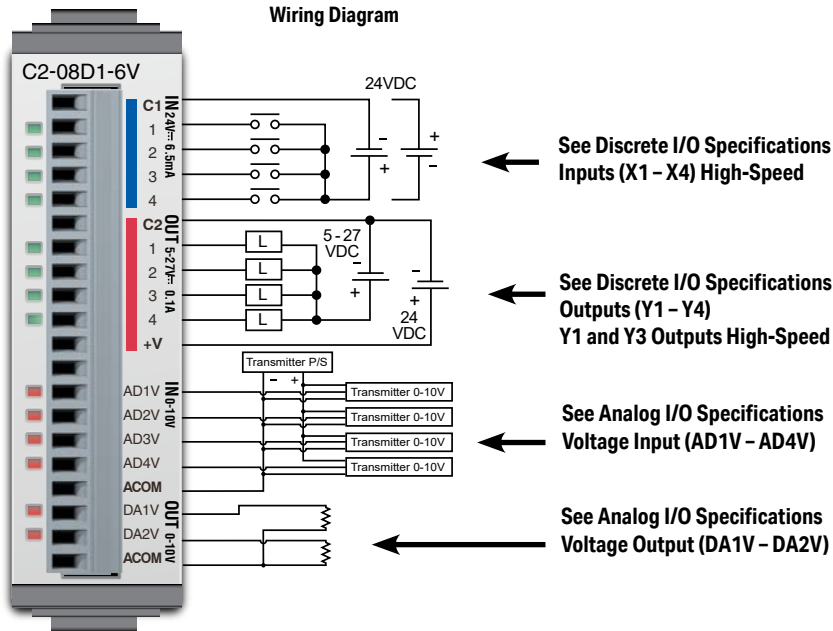

General Specifications	
Current Consumption at 24VDC	80mA max (All Points On)
Terminal Block Replacement Part No.	C0-16TB
Weight	48g

NOTE: Please refer to the Analog I/O Configuration section in Chapter 3 for information on using the analog I/O.



NOTE: There are no ZIPLink pre-wired PLC connection cables and modules for the Analog Option Slot Modules (cannot mix discrete I/O and analog I/O signals in a ZIPLink cable).

C2-08D1-6V (continued)

X1 - X4

Discrete I/O Specifications - Inputs	
Inputs per Module	4 (Source/Sink)
Operating Voltage Range	24VDC
Input Voltage Range	21.6 - 26.4 VDC
Input Current	Typ 6.5 mA @ 24VDC
Max. Input Current	7mA @ 26.4 VDC
Input Impedance	3.9 kΩ @ 24VDC
Input Frequency (Max)	X1-X4: 100kHz (3m cable)
ON Voltage Level	>19VDC
OFF Voltage Level	< 2VDC
Minimum ON Current	4.5 mA
Maximum OFF Current	0.5 mA
OFF to ON Response	Typ 3μs Max 5μs
ON to OFF Response	Typ 1μs Max 3μs
Status Indicators	Logic Side (4 points, green LED)
Commons	1 (4 points/common)

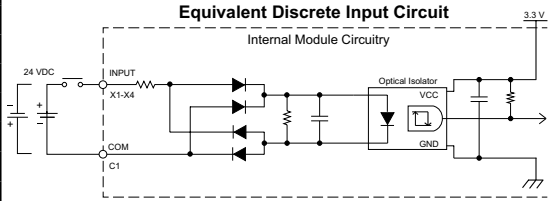

C2-08D1-6V Temperature Derating Chart

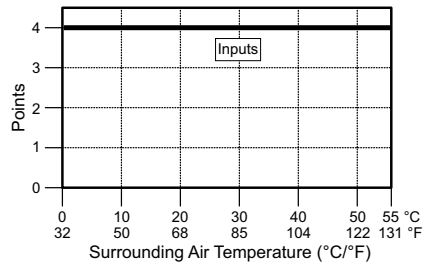

Maximum Number of High Speed Counters	
Up	4
Down	4
Up/Down	2
Pulse/Direction	2
Quadrature A-B	2
Quadrature A-B+Z	1

Y1 - Y4

Discrete I/O Specifications - Outputs	
Outputs per Module	4 (Sink)
Operating Voltage Range	5-27 VDC
Maximum Output Current	0.1 A/point; 0.4 A/common
Minimum Output Current	0.2 mA
Maximum Leakage Current	0.1 mA @ 30.0 VDC
On Voltage Drop	0.5 VDC @ 0.1 A
Maximum Inrush Current	150 mA for 10ms
Output Frequency (Max)	Y1, Y3: 100kHz (3m cable)
OFF to ON Response	< 5μs (Duty 40-60%, Load current 20mA)
ON to OFF Response	< 5μs (Duty 40-60%, Load current 20mA)
Status Indicators	Logic Side (4 points, red LED)
Commons	1 (4 points/common)
External DC Power Required	20-28 VDC Maximum @ 60mA (All points on)

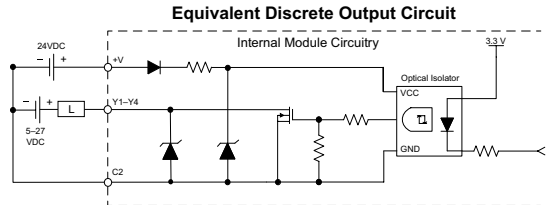

C2-08D1-6V Temperature Derating Chart

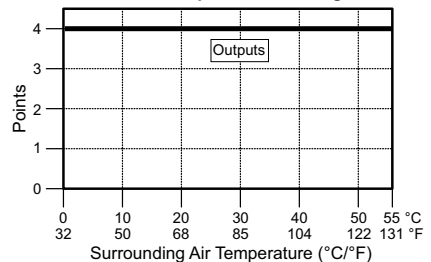

Maximum Number of High Speed Outputs	
Pulse Train	2
Pulse Width Modulation	2

AD1V - AD4V

Analog Specifications - Voltage Input	
Inputs per Module	4 (voltage)
Input Range	0-10 VDC
Resolution	12-bit
Conversion Time	50ms
Input Impedance	40kΩ
Input Stability	±2 LSB maximum
Full-Scale Calibration Error	±2% maximum
Offset Calibration Error	±25mV maximum
Accuracy vs. Temperature Error	±100ppm/°C maximum

Analog Voltage Input Circuit

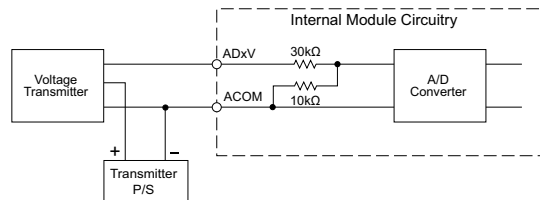

DA1V - DA2V

Analog Specifications - Voltage Output	
Outputs per Module	2 (voltage)
Output Range	0-10 VDC
Resolution	12-bit
Conversion Time	1ms
Load Impedance	4kΩ minimum (output current 2.5 mA maximum)
Full-Scale Calibration Error	±2% maximum
Offset Calibration Error	±25mV maximum
Accuracy vs. Temperature Error	±100ppm/°C maximum

Analog Voltage Output Circuit

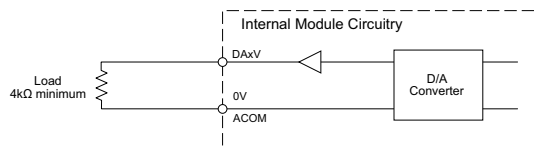

C2-08D2-6V – 4 DC Input (Sink/Source)/4 Sourcing DC Output

4 Analog Voltage Input

2 Analog Voltage Output Option Slot I/O Module

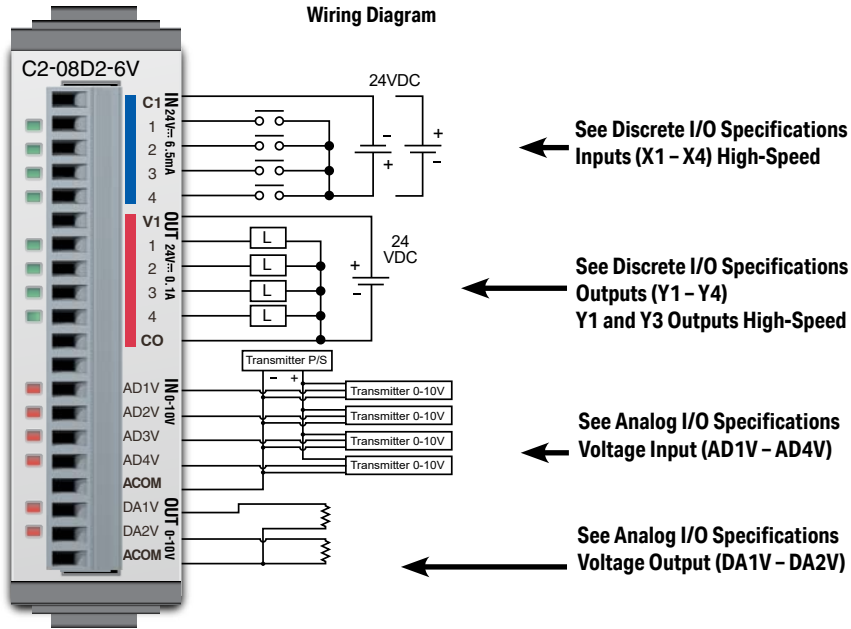

General Specifications	
Current Consumption at 24VDC	80mA max (All Points On)
Terminal Block Replacement Part No.	CO-16TB
Weight	48g

NOTE: Please refer to the Analog I/O Configuration section in Chapter 3 for information on using the analog I/O.

NOTE: There are no ZIPLink pre-wired PLC connection cables and modules for the Analog Option Slot Modules (cannot mix discrete I/O and analog I/O signals in a ZIPLink cable).



X1 - X4

Discrete I/O Specifications - Inputs	
Inputs per Module	4 (Source/Sink)
Operating Voltage Range	24VDC
Input Voltage Range	21.6 – 26.4 VDC
Input Current	Typ 6.5 mA @ 24VDC
Max. Input Current	7mA @ 26.4 VDC
Input Impedance	3.9 kΩ @ 24VDC
Input Frequency (Max)	X1-X4: 100kHz (3m cable)
ON Voltage Level	>19VDC
OFF Voltage Level	< 2VDC
Minimum ON Current	4.5 mA
Maximum OFF Current	0.5 mA
OFF to ON Response	Typ 3μs Max 5μs
ON to OFF Response	Typ 1μs Max 3μs
Status Indicators	Logic Side (4 points, green LED)
Commons	1 (4 points/common)

Maximum Number of High Speed Counters	
Up	4
Down	4
Up/Down	2
Pulse/Direction	2
Quadrature A-B	2
Quadrature A-B+Z	1

Y1 - Y4

Discrete I/O Specifications - Outputs	
Outputs per Module	4 (Source)
Operating Voltage Range	24VDC
Output Voltage Range	19.2-30 VDC
Maximum Output Current	0.1 A/point , 0.4 A/common
Minimum Output Current	0.2 mA
Maximum Leakage Current	0.1mA @ 30VDC
On Voltage Drop	0.5 VDC@ 0.1 mA
Maximum Inrush Current	150mA for 10ms
Output Frequency (Max)	Y1, Y3: 100kHz (3m cable)
OFF to ON Response	< 5μs (Duty 40–60%, Load current 20mA)
ON to OFF Response	< 5μs (Duty 40–60%, Load current 20mA)
Status Indicators	Logic Side (4 points, red LED)
Commons	1 (4 points/common)

Maximum Number of High Speed Outputs	
Pulse Train	2
Pulse Width Modulation	2

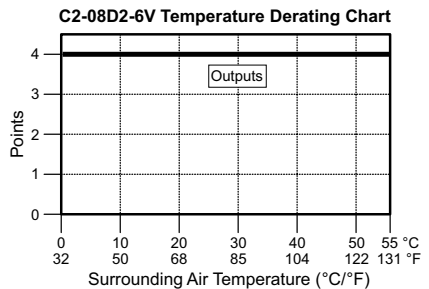
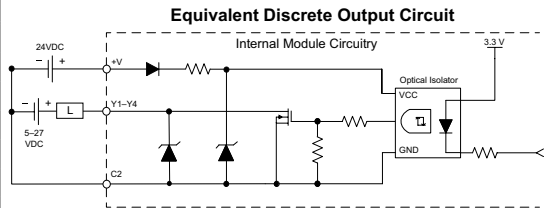
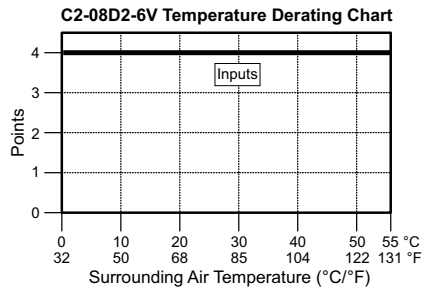
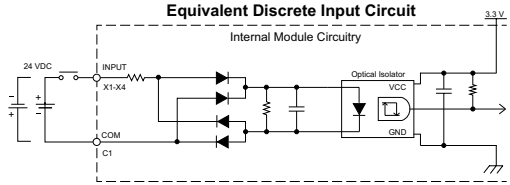

C2-08D2-6V (continued)

AD1V - AD4V

Analog Specifications - Voltage Input	
Inputs per Module	4 (voltage)
Input Range	0–10 VDC
Resolution	12-bit
Conversion Time	50ms
Input Impedance	40kΩ
Input Stability	±2 LSB maximum
Full-Scale Calibration Error	±2% maximum
Offset Calibration Error	±25mV maximum
Accuracy vs. Temperature Error	±100ppm/°C maximum

Analog Voltage Input Circuit

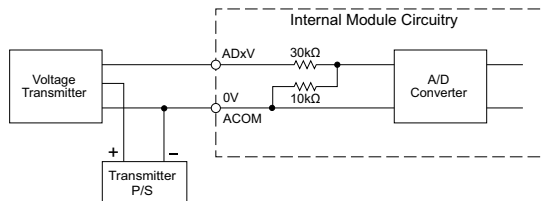

DA1V - DA2V

Analog Specifications - Voltage Output	
Outputs per Module	2 (voltage)
Output Range	0–10 VDC
Resolution	12-bit
Conversion Time	1ms
Load Impedance	4kΩ minimum (output current 2.5 mA maximum)
Full-Scale Calibration Error	±2% maximum
Offset Calibration Error	±25mV maximum
Accuracy vs. Temperature Error	±100ppm/°C maximum

Analog Voltage Output Circuit

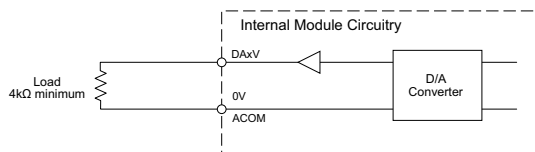

C2-08DR-6V – 4 DC Input (Sink/Source)/4 Relay Output

4 Analog Voltage Input

2 Analog Voltage Output Option Slot I/O Module

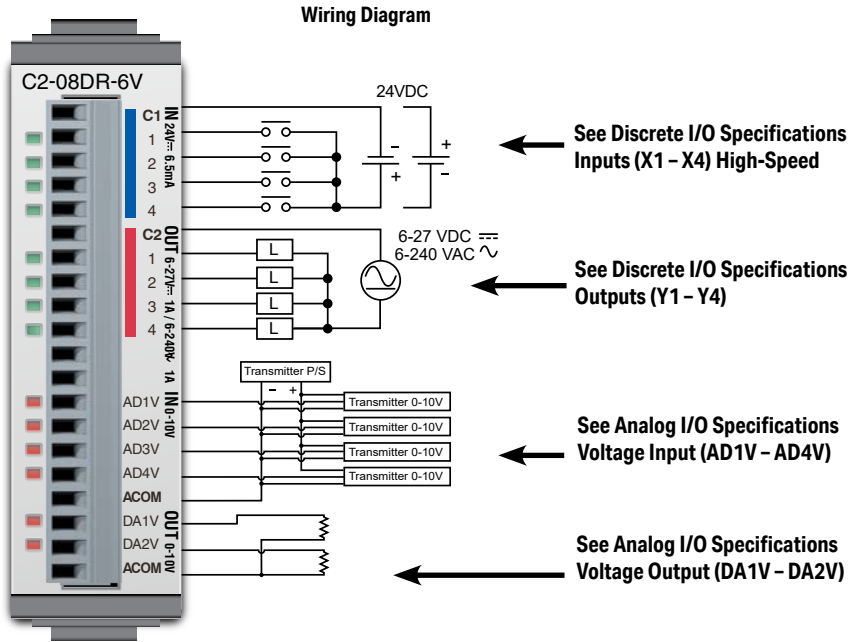

General Specifications	
Current Consumption at 24VDC	80mA max (All Points On)
Terminal Block Replacement Part No.	C0-16TB
Weight	57g

NOTE: Please refer to the Analog I/O Configuration section in Chapter 3 for information on using the analog I/O.



NOTE: There are no ZIPLink pre-wired PLC connection cables and modules for the Analog Option Slot Modules (cannot mix discrete I/O and analog I/O signals in a ZIPLink cable).

C2-08DR-6V (continued)

X1 - X4

Discrete I/O Specifications - Inputs	
Inputs per Module	4
Operating Voltage Range	24VDC
Input Voltage Range	21.6 – 26.4 VDC
Input Current	Typ 6.5 mA @ 24VDC
Max. Input Current	7mA @ 26.4 VDC
Input Impedance	3.9 kΩ @ 24VDC
Input Frequency (Max)	X1-X4: 100kHz (3m cable)
ON Voltage Level	>19VDC
OFF Voltage Level	< 2VDC
Minimum ON Current	4.5 mA
Maximum OFF Current	0.5 mA
OFF to ON Response	Typ 3μs Max 5μs
ON to OFF Response	Typ 1μs Max 3μs
Status Indicators	Logic side (4 points, green LED)
Commons	1 (4 points/common)

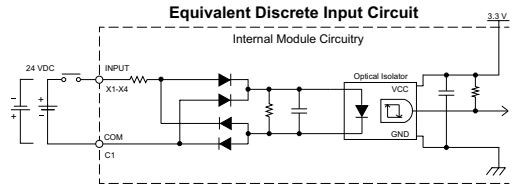

C2-08DR-6V Temperature Derating Chart

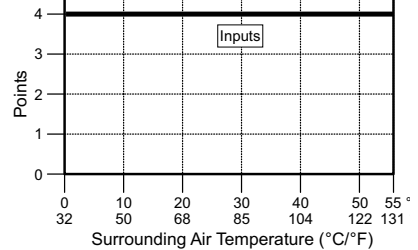

Y1 - Y4

Maximum Number of High Speed Counters	
Up	4
Down	4
Up/Down	2
Pulse/Direction	2
Quadrature A-B	2
Quadrature A-B+Z	1

Discrete I/O Specifications - Outputs	
Outputs per Module	4
Operating Voltage Range	6–27 VDC, 6–240 VAC
Output Type	Relay, form A (SPST)
AC Frequency	47–63 Hz
Maximum Current	1A/point (resistive)
Minimum Load Current	5mA @ 5VDC
Maximum Inrush Current	3A for 10ms
OFF to ON Response	< 15ms
ON to OFF Response	< 15ms
Status Indicators	Logic Side (4 points, red LED)
Commons per Module	1 (4 points/common)

Equivalent Discrete Output Circuit

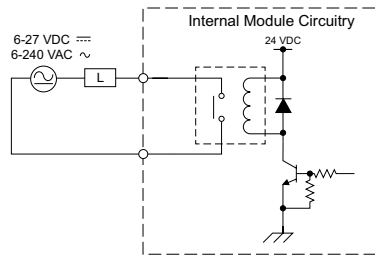

C2-08DR-6V Temperature Derating Chart

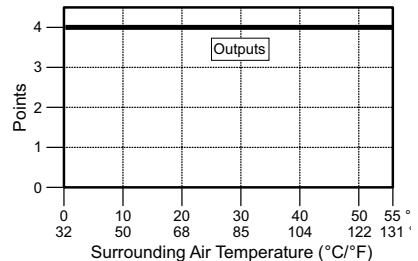

Typical Relay Life (Operations) at Room Temperature	
Voltage & Load Type	Relay Life
30VDC, 1A Resistive	200,000 cycles
30VDC, 1A Inductive	100,000 cycles
250VAC, 1A Resistive	200,000 cycles
250VAC, 1A Inductive	50,000 cycles

ON to OFF = 1 cycle

AD1V - AD4V

Analog Specifications - Voltage Input	
Inputs per Module	4 (voltage)
Input Range	0-10 VDC
Resolution	12-bit
Conversion Time	50ms
Input Impedance	40kΩ
Input Stability	±2 LSB maximum
Full-Scale Calibration Error	±2% maximum
Offset Calibration Error	±25mV maximum
Accuracy vs. Temperature Error	±100ppm/°C maximum

Analog Voltage Input Circuit

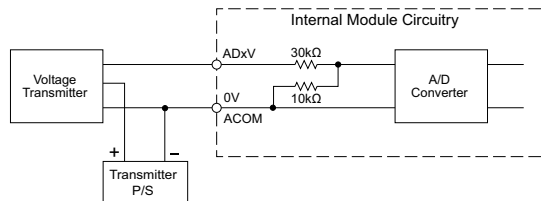

DA1V - DA2V

Analog Specifications - Voltage Output	
Outputs per Module	2 (voltage)
Output Range	0-10 VDC
Resolution	12-bit
Conversion Time	1ms
Load Impedance	4kΩ minimum (output current 2.5 mA maximum)
Full-Scale Calibration Error	±2% maximum
Offset Calibration Error	±25mV maximum
Accuracy vs. Temperature Error	±100ppm/°C maximum

Analog Voltage Output Circuit

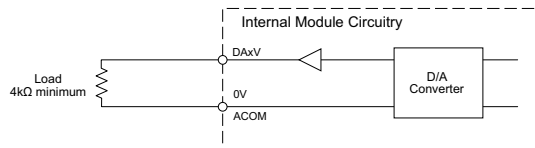

C2-08DR-6V (continued)

Insulation Requirements for IEC/UL 61010-1 and 61010-2-201 (sections 6.5 and 6.7)**Input to Output Insulation**

Basic insulation is provided between the Relay Output and the closest Input terminal. When connecting the Relay Output to a circuit that exceeds 100VAC (141VDC) more than the closest input circuit an additional basic insulation layer must be added to the input circuit.

Additional Basic Insulation Examples

- Supplementary Insulation: Interposing relay, additional insulating material,... (sec. 6.5.3)
- Automatic Disconnection of the Supply: Properly sized breaker (sec. 6.5.5)
- Current or Voltage Limiting device: Properly sized fuse (sec. 6.5.6)

Basic insulation requires a clearance distance of 1.5 mm or more, a creepage distance of 2.5 mm or more, and dielectric voltage withstand of 1500Vrms.

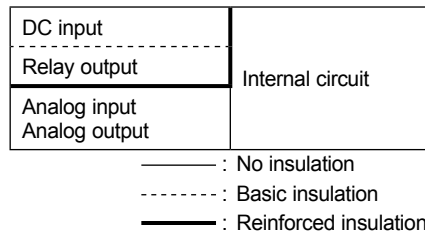

C2-08AR-6V – 4 AC Input (Sink/Source) /4 Relay Output

4 Analog Voltage Input

2 Analog Voltage Output Option Slot I/O Module

Wiring Diagram

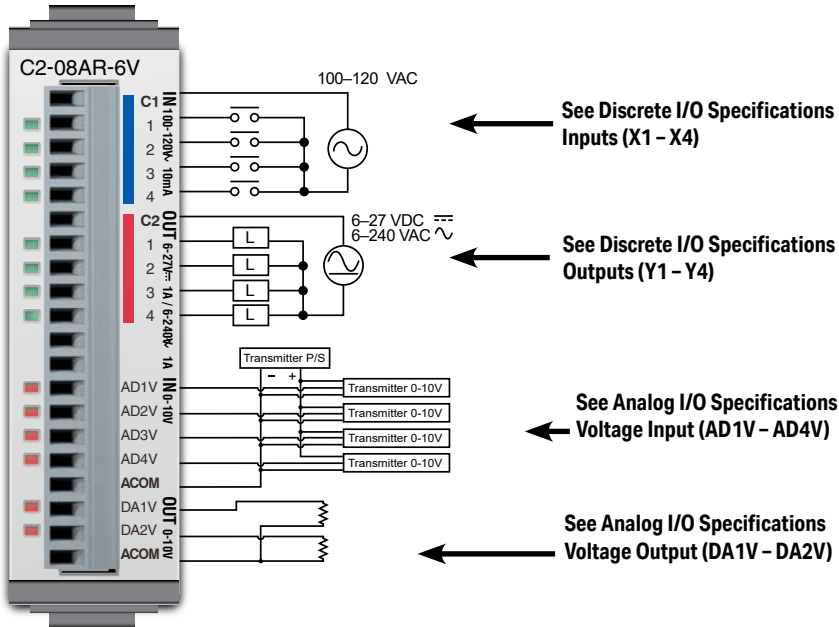

General Specifications	
Current Consumption at 24VDC	100mA max (All Points On)
Terminal Block Replacement Part No.	C0-16TB
Weight	58g

NOTE: Please refer to the Analog I/O Configuration section in Chapter 3 for information on using the analog I/O.



NOTE: There are no ZIPLink pre-wired PLC connection cables and modules for the Analog Option Slot Modules (cannot mix discrete I/O and analog I/O signals in a ZIPLink cable).

C2-08AR-6V (continued)

X1 - X4

Discrete I/O Specifications - Inputs	
Inputs per Module	4
Operating Voltage Range	100-120 VAC
AC Frequency	47-63 Hz
Input Current	Typ 8.5 mA @ 100VAC at 50Hz Typ 10mA @ 100VAC at 60Hz
Maximum Input Current	16mA @ 144VAC
Input Impedance	15kΩ @ 50Hz 12kΩ @ 60Hz
ON Voltage Level	> 60VAC
OFF Voltage Level	< 20VAC
Minimum ON Current	5mA
Maximum OFF Current	2mA
OFF to ON Response	< 40ms
ON to OFF Response	< 40ms
Status Indicators	Logic Side (4 points, green LED)
Commons	1 (4 points/common)

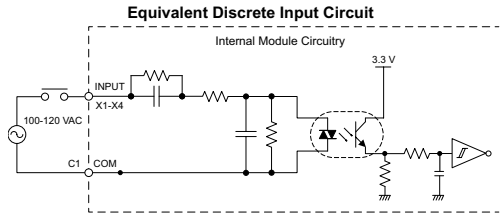

C2-08AR-6V Temperature Derating Chart

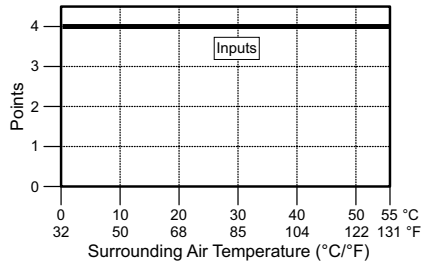

Y1 - Y4

Discrete I/O Specifications - Outputs	
Outputs per Module	4
Operating Voltage Range	6-27 VDC, 6-240 VAC
Output Type	Relay, form A (SPST)
AC Frequency	47-63 Hz
Maximum Current	1A/point (resistive)
Minimum Load Current	5mA @ 5VDC
Maximum Inrush Current	3A for 10ms
OFF to ON Response	< 15ms
ON to OFF Response	< 15ms
Status Indicators	Logic Side (4 points, red LED)
Commons per Module	1 (4 points/common)

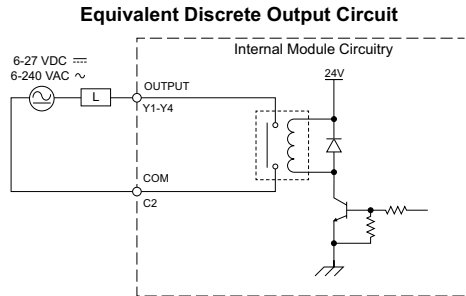

C2-08AR-6V Temperature Derating Chart

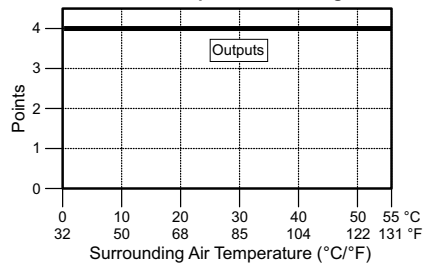

Typical Relay Life (Operations) at Room Temperature	
Voltage & Load Type	Relay Life
30VDC, 1A Resistive	200,000 cycles
30VDC, 1A Inductive	100,000 cycles
250VAC, 1A Resistive	200,000 cycles
250VAC, 1A Inductive	50,000 cycles

ON to OFF = 1 cycle

C2-08AR-6V (continued)

AD1V - AD4V

Analog Specifications - Voltage Input	
Inputs per Module	4 (voltage)
Input Range	0-10 VDC
Resolution	12-bit
Conversion Time	50ms
Input Impedance	40kΩ
Input Stability	±2 LSB maximum
Full-Scale Calibration Error	±2% maximum
Offset Calibration Error	±25mV maximum
Accuracy vs. Temperature Error	±100ppm/°C maximum

Analog Voltage Input Circuit

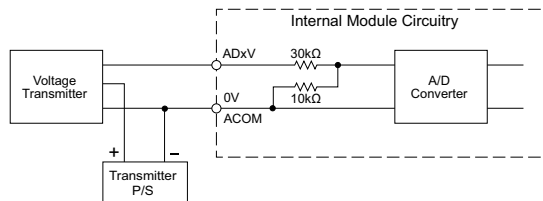

DA1V - DA2V

Analog Specifications - Voltage Output	
Outputs per Module	2 (voltage)
Output Range	0-10 VDC
Resolution	12-bit
Conversion Time	1ms
Load Impedance	4kΩ minimum (output current 2.5 mA maximum)
Full-Scale Calibration Error	±2% maximum
Offset Calibration Error	±25mV maximum
Accuracy vs. Temperature Error	±100ppm/°C maximum

Analog Voltage Output Circuit

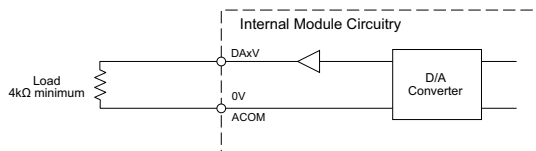

C2-08AR-6V (continued)

Insulation Requirements for IEC/UL 61010-1 and 61010-2-201 (sections 6.5 and 6.7)

Input to Output Insulation

Basic insulation is provided between the Relay Output and the closest Input terminal. When connecting the Relay Output to a circuit that exceeds 100VAC (141VDC) more than the closest input circuit an additional basic insulation layer must be added to the input circuit.

Additional Basic Insulation Examples

- Supplementary Insulation: Interposing relay, additional insulating material,... (sec. 6.5.3)
- Automatic Disconnection of the Supply: Properly sized breaker (sec. 6.5.5)
- Current or Voltage Limiting device: Properly sized fuse (sec. 6.5.6)

Basic insulation requires a clearance distance of 1.5 mm or more, a creepage distance of 2.5 mm or more, and dielectric voltage withstand of 1500Vrms.

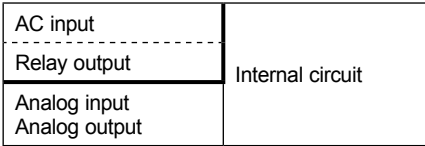

- : No insulation
- : Basic insulation
- : Reinforced insulation

Option Slot Intelligent Module Specifications

General Specifications for all CLICK PLUS Option Slot Intelligent Modules

CLICK PLUS Option Slot Module General Specifications	
Operating Temperature	32°F to 131°F [0°C to 55°C]
Storage Temperature	-4°F to 158°F [-20°C to 70°C] IEC 60068-2-1 (Test Ab, Cold) IEC 60068-2-2 (Test Bb, Dry Heat) IEC 60068-2-14 (Test Na, Thermal Shock)
Ambient Humidity	30% to 95% relative humidity (non-condensing)
Environmental Air	No corrosive gases The level for the environmental pollution is 2 (UL840)
Environment	For Indoor Use Only
Vibration	IEC60068-2-6 (Test Fc) 5-9Hz:3.5mm amplitude, 9-150Hz 1.0G 10 sweep cycles per axis on each of 3 mutually perpendicular axes.
Shock	IEC60068-2-27 (Test Ea) 15G peak, 11ms duration, 3 shocks in each direction per axis, on 3 mutually perpendicular axes.
Noise Immunity	<EN61131-2> EN61000-4-2 (ESD) EN61000-4-3 (RFI) EN61000-4-4 (FTB) EN61000-4-5 (Surge) EN61000-4-6 (Conducted) EN61000-4-8 (Power frequency magnetic field immunity) <Local Test> Impulse Immunity : 1000V @ 1uS pulse
Emissions	EN55011 Class A (Radiated RF emission)
Agency Approvals	UL61010 (File No. E157382, E316037); CE (EN61131-2); CUL Canadian C22.2
Other	RoHS 2011/65/EU Amendment (EU)2015/863

C2-DCM – Data Communication Module

The CLICK PLUS serial communications module provides two RS-232/RS-485 ports. This configuration allows Modbus master/slave networking or connection to serial devices using ASCII communications protocol.

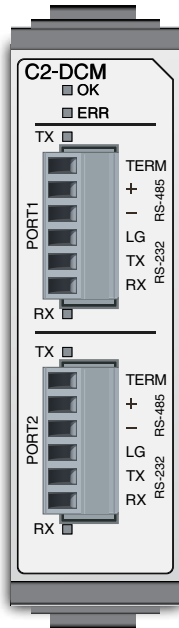

Port Specifications	
Number of Ports	2
Port Types	RS-232, RS-485 (2-wire)
Supported Protocols	Modbus RTU, ASCII (user-defined)
Communications Parameters	<ul style="list-style-type: none"> Baud rate: 2400, 4800, 9600, 19200, 38400, 57600, 115.2k bps Data bit: 7 bits, 8 bits Parity: None, Odd, Even Stop bit: 1 bit, 2 bits Flow Control: None
RS-485 Terminating Resistor	120Ω, Internal
Status Indicator LEDs	OK, ERR, TX (per port), RX (per port)

Modbus Specifications	
Station Number Range	1-247
Timeout Setting	100ms, 200ms, 500ms, 1s, 2s, 5s, 10s, 20s, 30s
Character Timeout	2-1000ms
Response Delay Time	0-5000ms
Modbus Function Codes	Master/Slave: 01 - Read Coil Status 02 - Read Input Bits 03 - Read Holding Register 04 - Read Input Register 05 - Write Single Coil 06 - Write Single Register 15 - Write Multiple Coils 16 - Write Multiple Registers

General Specifications	
Current Consumption at 24VDC	60mA max
Weight	41g

Terminal Block Specifications	
Connector Type	Pluggable Terminal Block
Number of Pins	6 (x2 terminal blocks)
Pitch	3.50 mm
Wire Size Range	22-26 AWG
Stripping Length	7.0 mm
Wire Specification	Lead-free, heat resistant, polyvinyl chloride insulated copper wire, rated over 80°C
Screw Thread	M2.0
Tightening Torque	1.7 lb-inch [0.19 N·m]
Recommended Cable	Shielded cable (AutomationDirect Q8105-1 or Q8302-1 recommended)

Wiring Diagrams

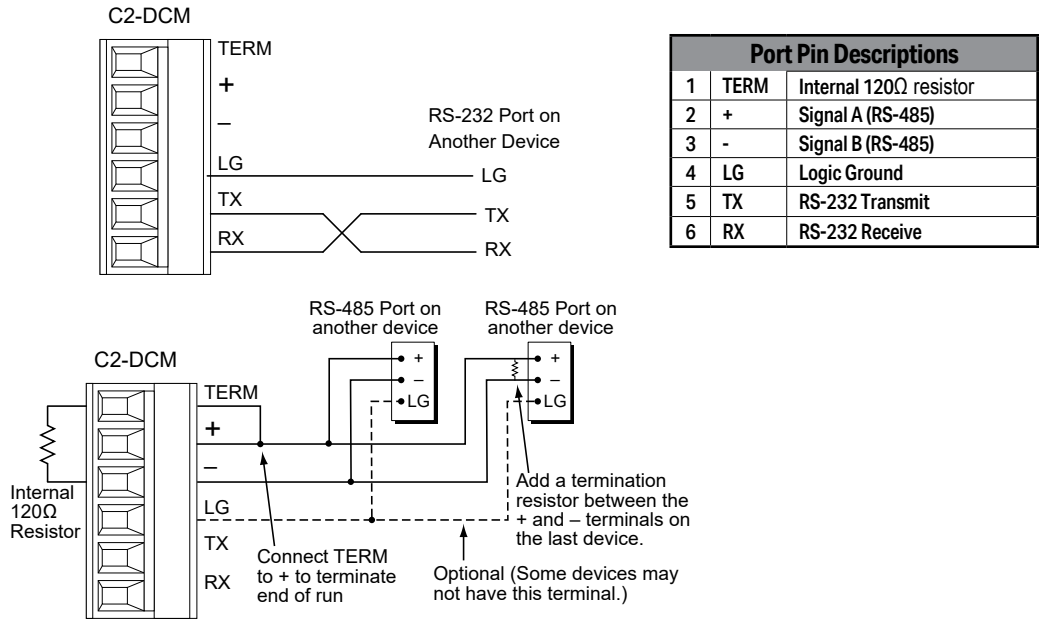

LED Indicators

OK LED (Green)	
On	Operating Normally
Blink	Updating Now
Off	No Power or Program Stopped

ERROR LED (Red)	
Blink	Port Communication Error
Off	No Error

TX & RX LED (Green)	
On	Com Port Data Active
Off	No Communication

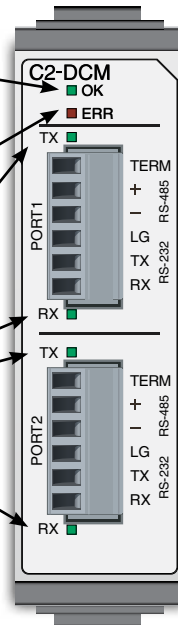

Stackable I/O Module Specifications

I/O Terminal Block Specifications for CPUs and I/O Modules



11-Pin Terminal Block,
C0-8TB

11-pin Terminal Block Specifications	
Connector Type	Pluggable Terminal Block
Number of Pins	11 pt
Pitch	3.50 mm
Wire Range	28–16 AWG
Wire Strip Length	7mm
Screw Size	M2.0
Screw Torque	2.0 to 2.2 lb-inch
AutomationDirect Part Number	C0-8TB

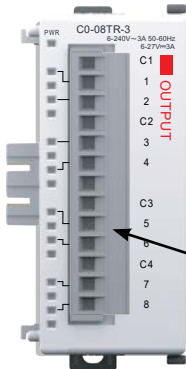

13-Pin Terminal Block,
C0-8TB-1

13-pin Terminal Block Specifications	
Connector Type	Pluggable Terminal Block
Number of Pins	13 pt
Pitch	5.08 mm
Wire Range	12–20 AWG
Wire Strip Length	7.0–8.0 mm
Screw Size	M2.5
Screw Torque	4.51 lb-inch
AutomationDirect Part Number	C0-8TB-1

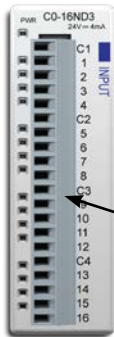

20-Pin Terminal Block,
C0-16TB

20-pin Terminal Block Specifications	
Connector Type	Pluggable Terminal Block
Number of Pins	20 pt
Pitch	3.50 mm
Wire Range	28–16 AWG
Wire Strip Length	7mm
Screw Size	M2.0
Screw Torque	2.0 to 2.2 lb-inch
AutomationDirect Part Number	C0-16TB

LED Indicators

All CLICK Discrete I/O modules have an LED Power Indicator, PWR. When this LED is on, the I/O module is receiving 24VDC through the backplane connector. The input modules have green LEDs and the output modules have red LEDs respectively as the status indicator. When the LED is on, the I/O point is on.

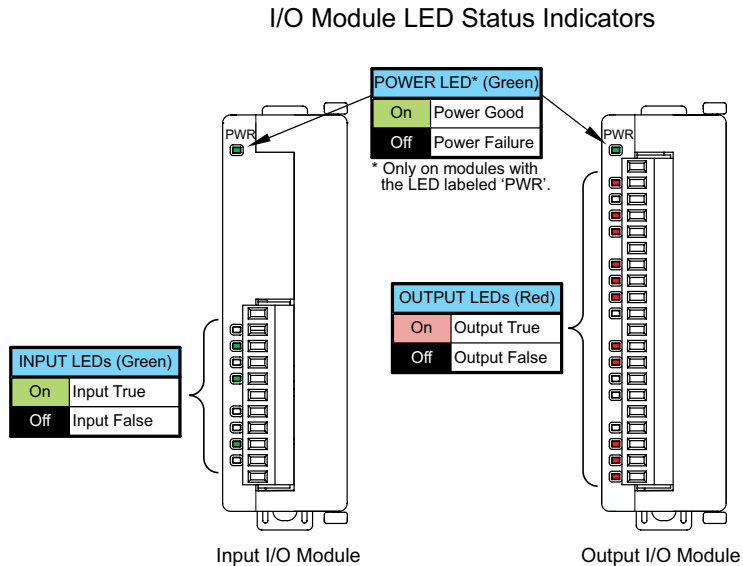

C0-08SIM – 8-Point Toggle Switch Input Module

8-point toggle switch input module provides for simple simulation of system discrete inputs.



Input Specifications	
Inputs per Module	8 Toggle Switches
OFF to ON Response	Max 140ms, Typ 90ms
ON to OFF Response	Max 110ms, Typ 60ms
Status Indicators	Logic Side (8 points, green LED) Power Indicator (green LED)
Bus Power Required	Max. 50mA (All points ON)
Weight	2.9 oz (84g)



CAUTION

The C0-08SIM unit toggle switch can get hot when mounted in hot environment. Wear heat-resistant gloves before use, as it may cause burns.

Chapter 2: Specifications

C0-08ND3 – 8-Point Sink/Source DC Input Module

8-point 12–24 VDC current sinking or sourcing input module, 2 commons, isolated, removable terminal block included.

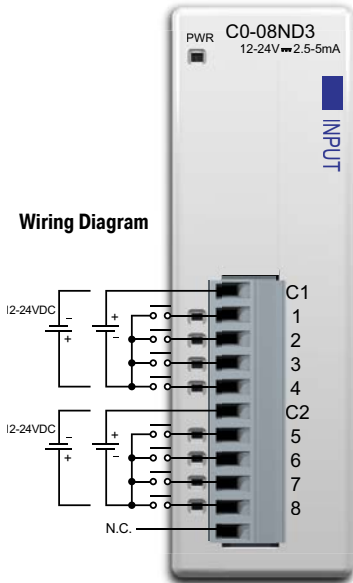

N.C. = Not Connected

Input Specifications	
Inputs per Module	8 (Sink/Source)
Operating Voltage Range	12–24 VDC
Input Voltage Range	10.8 – 26.4 VDC
Input Current	Typ 5mA @ 24VDC
Maximum Input Current	7mA @ 26.4 VDC
Input Impedance	4.7 kΩ @ 24VDC
ON Voltage Level	> 8.0 VDC
OFF Voltage Level	< 3.0 VDC
Minimum ON Current	1.4 mA
Maximum OFF Current	0.5 mA
OFF to ON Response	Max 3.5 ms, Typ 2ms
ON to OFF Response	Max 4 ms, Typ 2.5 ms
Status Indicators	Logic Side (8 points, green LED) Power Indicator (green LED)
Commons	2 (4 points/common) Isolated
Bus Power Required (24VDC)	Max. 30mA (All Inputs On)
Terminal Block Replacement	AutomationDirect p/n C0-8TB
Weight	2.8 oz (80g)

Equivalent Input Circuit

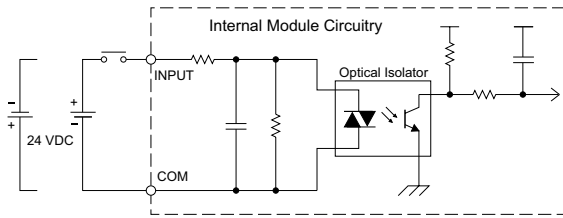

Input Module Temperature Derating Chart

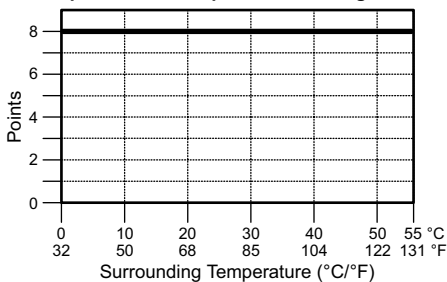

ZIPLink Pre-Wired PLC Connection Cables and Modules for CLICK PLC

- 11-pin connector cable
- ZL-C0-CBL11 (0.5 m length)
- ZL-C0-CBL11-1 (1.0 m length)
- ZL-C0-CBL11-2 (2.0 m length)



ZL-RTB20 20-pin feed-through connector module



C0-08ND3-1 – 8-Point Sink/Source DC Input Module

8-point 3.3–5 VDC current sinking or sourcing input module, 2 commons, isolated, removable terminal block included.

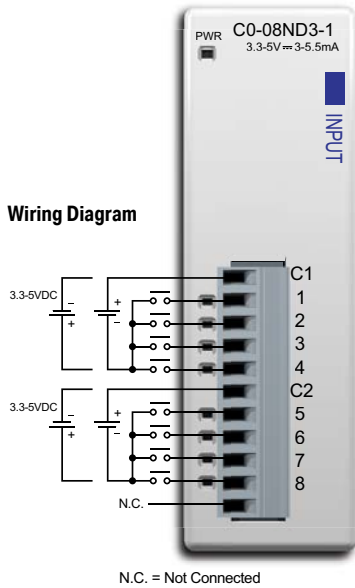

Input Specifications	
Inputs per Module	8 (Sink/Source)
Operating Voltage Range	3.3–5 VDC
Input Voltage Range	2.8 – 5.5 VDC
Input Current	Typ 5.5 mA @ 5 VDC
Maximum Input Current	7.5 mA @ 5.5 VDC
Input Impedance	680 Ω
ON Voltage Level	> 2.2 VDC
OFF Voltage Level	< 0.8 VDC
Minimum ON Current	1.4 mA
Maximum OFF Current	0.2 mA
OFF to ON Response	Max. 3ms Typ. 1.6 ms
ON to OFF Response	Max. 4ms Typ. 2.3 ms
Status Indicators	Logic Side (8 points, green LED) Power Indicator (green LED)
Commons	2 (4 points/common) Isolated
Bus Power Required (24VDC)	Max. 30mA (All Inputs On)
Terminal Block Replacement	AutomationDirect p/n C0-8TB
Weight	2.8 oz (80g)

Equivalent Input Circuit

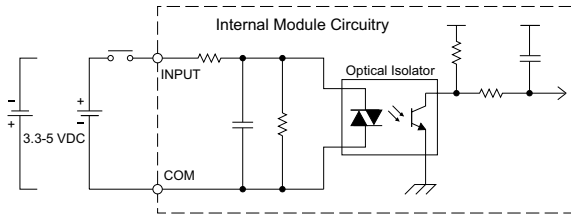

Input Module Temperature Derating Chart

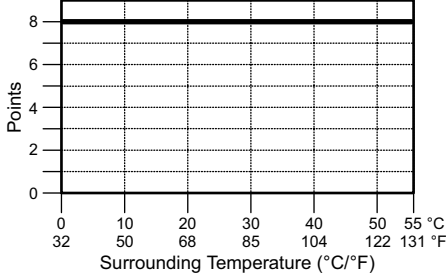

ZIPLink Pre-Wired PLC Connection Cables and Modules for CLICK PLC

- 11-pin connector cable
- ZL-C0-CBL11 (0.5 m length)
- ZL-C0-CBL11-1 (1.0 m length)
- ZL-C0-CBL11-2 (2.0 m length)



- ZL-RTB20
- 20-pin feed-through connector module



Chapter 2: Specifications

C0-16ND3 – 16-Point Sink/Source DC Input Module

16-point 24VDC current sinking or sourcing input module, 4 commons, isolated, removable terminal block included.

Wiring Diagram

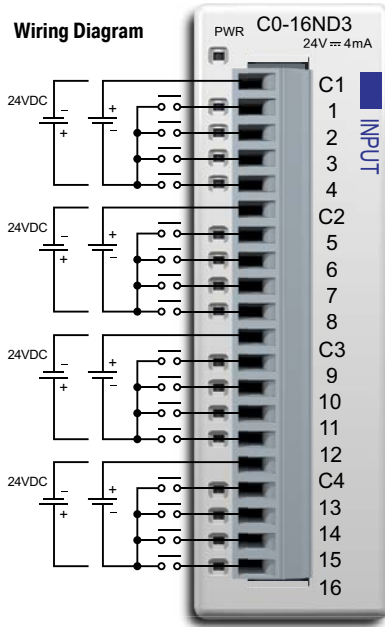

Input Specifications

Inputs per Module	16 (Sink/Source)
Operating Voltage Range	24VDC
Input Voltage Range	21.6 – 26.4 VDC
Input Current	Typ 4.0 mA @ 24VDC
Maximum Input Current	5.0 mA @ 26.4 VDC
Input Impedance	6.8 kΩ @ 24VDC
ON Voltage Level	> 19VDC
OFF Voltage Level	< 7VDC
Minimum ON Current	3.5 mA
Maximum OFF Current	0.5 mA
OFF to ON Response	Max. 10ms Typ 2ms
ON to OFF Response	Max. 10ms Typ 3ms
Status Indicators	Logic Side (16 points, green LED) Power Indicator (green LED)
Commons	4 (4 points/common) Isolated
Bus Power Required (24VDC)	Max. 40 mA (All Inputs On)
Terminal Block Replacement	AutomationDirect p/n C0-16TB
Weight	3.2 oz (90g)

Equivalent Input Circuit

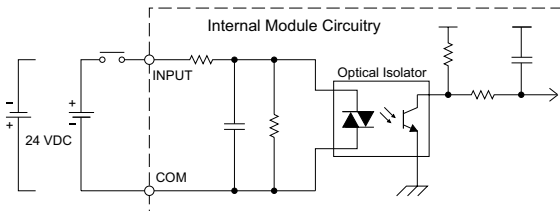

Z/PLink Pre-Wired PLC Connection Cables and Modules for CLICK PLC

- 20-pin connector cable
- ZL-C0-CBL20 (0.5 m length)
- ZL-C0-CBL20-1 (1.0 m length)
- ZL-C0-CBL20-2 (2.0 m length)



Input Module Temperature Derating Chart

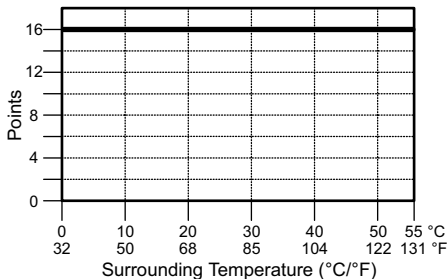

C0-08NE3 – 8-Point Sink/Source AC/DC Input Module

8-point 24VAC / 24VDC current sinking or sourcing input module, 2 commons, 4 points per common, removable terminal block included.

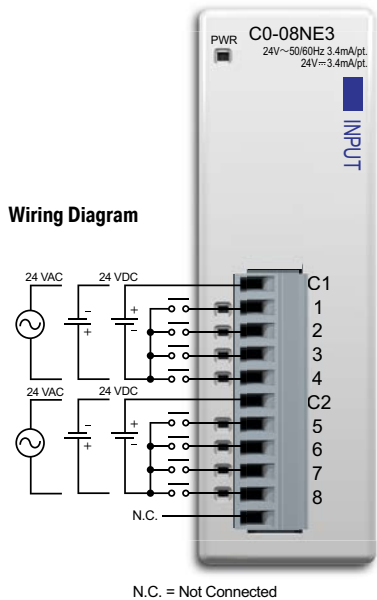

Input Specifications	
Inputs per Module	8 (Sink/Source)
Operating Voltage Range	24 VAC/VDC
Input Voltage Range	20.4 – 27.6 VAC/VDC
Peak Voltage	27.6 VAC/VDC
AC Frequency	47–63 Hz
Input Current	Typ 3.4 mA @ 24 VAC/VDC
Maximum Input Current	5.0 mA @ 27.6 VAC/VDC
Input Impedance	6.8 K Ω @ 24 VAC/VDC
ON Voltage Level	> 18.0 VAC/VDC
OFF Voltage Level	< 4.0 VAC/VDC
Minimum ON Current	2.5 mA
Maximum OFF Current	0.5 mA
OFF to ON Response	5–40 ms
ON to OFF Response	10–50 ms
Status Indicators	Logic Side (8 points, green LED) Power Indicator (green LED)
Commons	2 (4 points/common) Isolated
Bus Power Required (24VDC)	Max. 30mA (All Inputs On)
Terminal Block Replacement	AutomationDirect p/n C0-8TB
Weight	2.9 oz (82g)



NOTE: When using this module you must also use CLICK programming software version V1.20 or later.

Equivalent Input Circuit

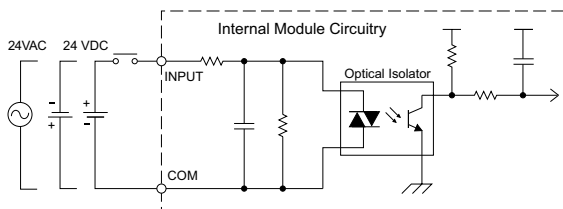

Input Module Temperature Derating Chart

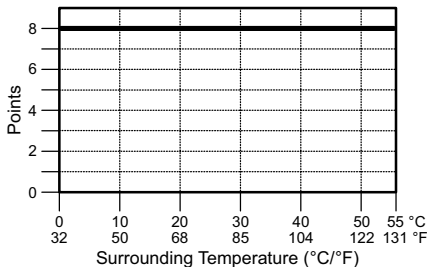

ZILink Pre-Wired PLC Connection Cables and Modules for CLICK PLC

- 11-pin connector cable
- ZL-C0-CBL11 (0.5 m length)
- ZL-C0-CBL11-1 (1.0 m length)
- ZL-C0-CBL11-2 (2.0 m length)



- ZL-RTB20
- 20-pin feed-through connector module



Chapter 2: Specifications

C0-16NE3 – 16-Point Sink/Source AC/DC Input Module

16-point 24VAC / 24VDC current sinking or sourcing input module, 4 commons, 4 points per common, removable terminal block included.

Wiring Diagram

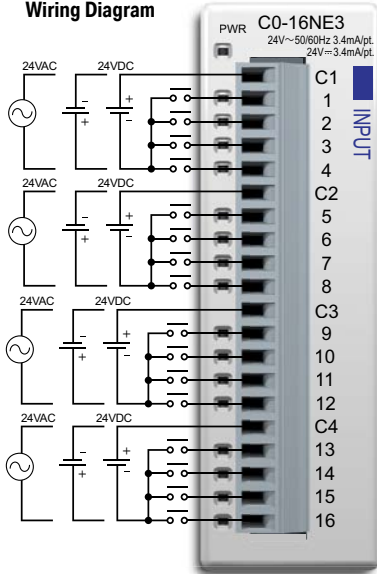

Input Specifications

Inputs per Module	16 (Sink/Source)
Operating Voltage Range	24 VAC/VDC
Input Voltage Range	20.4 – 27.6 VAC/VDC
Peak Voltage	27.6 VAC/VDC
AC Frequency	47-63 Hz
Input Current	Typ 3.4 mA @ 24 VAC/VDC
Maximum Input Current	5.0 mA @ 27.6 VAC/VDC
Input Impedance	6.8 kΩ @ 24 VAC/VDC
ON Voltage Level	> 18.0 VAC/VDC
OFF Voltage Level	< 4.0 VAC/VDC
Minimum ON Current	2.5 mA
Maximum OFF Current	0.5 mA
OFF to ON Response	5–40 ms
ON to OFF Response	10–50 ms
Status Indicators	Logic Side (16 points, green LED) Power Indicator (green LED)
Commons	4 (4 points/common) Isolated
Bus Power Required (24VDC)	Max. 40mA (All Inputs On)
Terminal Block Replacement	AutomationDirect p/n C0-16TB
Weight	3.2 oz (90g)



NOTE: When using this module you must also use CLICK programming software version V1.20 or later.

ZIPLink Pre-Wired PLC Connection Cables and Modules for CLICK PLC

Equivalent Input Circuit

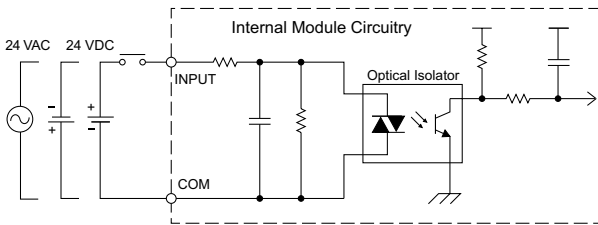

20-pin connector cable
 ZL-C0-CBL20 (0.5 m length)
 ZL-C0-CBL20-1 (1.0 m length)
 ZL-C0-CBL20-2 (2.0 m length)



Input Module Temperature Derating Chart

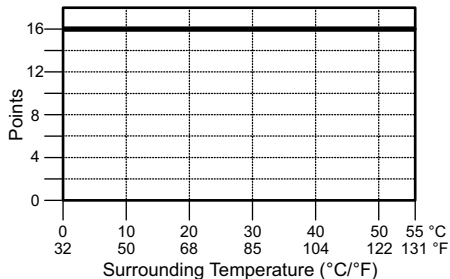

ZL-RTB20 20-pin
feed-through
connector module



ZL-LTB16-24-1
sensor input module

C0-08NA – 8-Point AC Input Module

8-point 100–120 VAC input module, 2 commons, isolated, removable terminal block included.

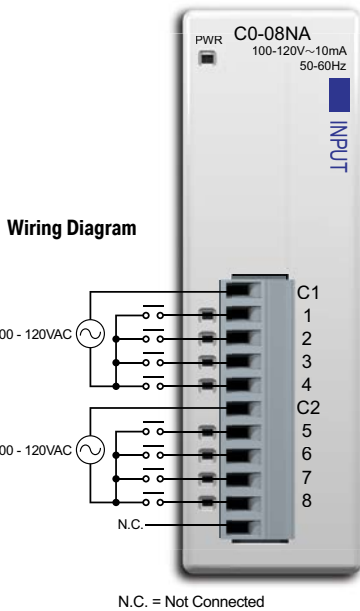

Input Specifications	
Inputs per Module	8
Operating Voltage Range	100–120 VAC
Input Voltage Range	80–144 VAC
AC Frequency	47–63 Hz
Input Current	Typ 8.5 mA @ 100VAC (50Hz) Typ 10mA @ 100VAC (60Hz)
Maximum Input Current	16mA @ 144VAC
Input Impedance	15kΩ (50 Hz), 12kΩ (60Hz)
ON Voltage Level	> 70VAC
OFF Voltage Level	< 20VAC
Minimum ON Current	5mA
Maximum OFF Current	2mA
OFF to ON Response	< 40ms
ON to OFF Response	< 40ms
Status Indicators	Logic Side (8 points, green LED) Power Indicator (green LED)
Commons	2 (4 points/common) Isolated
Bus Power Required (24VDC)	Max. 30mA (All Inputs On)
Terminal Block Replacement	AutomationDirect p/n C0-8TB
Weight	2.8 oz (80g)

Equivalent Input Circuit

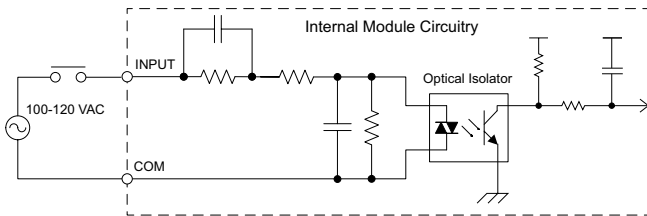

ZIPLink Pre-Wired PLC Connection Cables and Modules for CLICK PLC

- 11-pin connector cable
- ZL-C0-CBL11 (0.5 m length)
- ZL-C0-CBL11-1 (1.0 m length)
- ZL-C0-CBL11-2 (2.0 m length)



Input Module Temperature Derating Chart

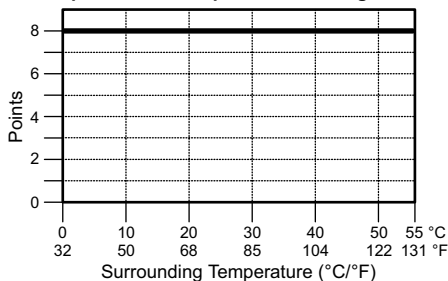

- ZL-RTB20
- 20-pin feed-through connector module



Chapter 2: Specifications

C0-08TD1 – 8-Point Sinking DC Output Module

8-point 3.3–27 VDC current sinking output module, 2 commons, 0.3 A/pt, removable terminal block included.

Wiring Diagram

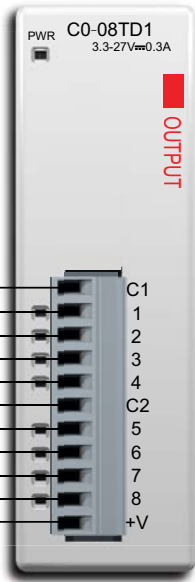
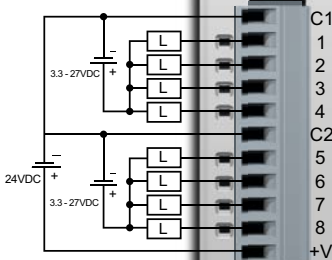

Output Specifications

Outputs per Module	8 (Sink)
Operating Voltage Range	3.3–27 VDC
Output Voltage Range	2.8–30 VDC
Maximum Output Current	0.3 A/point, 1.2 A/common
Minimum Output Current	0.5 mA
Maximum Leakage Current	0.1 mA @ 30.0 VDC
On Voltage Drop	1.5 VDC @ 0.3 A
Maximum Inrush Current	1A for 10ms
OFF to ON Response	< 0.5 ms
ON to OFF Response	< 0.5 ms
Status Indicators	Logic Side (8 points, red LED) Power Indicator (green LED)
Commons	2 (4 points/common)
External DC Power Required	21.6 – 26.4 VDC Max 15mA (All Outputs On)
Bus Power Required (24VDC)	Max. 50mA (All Outputs On)
Terminal Block Replacement	AutomationDirect p/n C0-8TB
Weight	2.8 oz (80g)

Equivalent Output Circuit

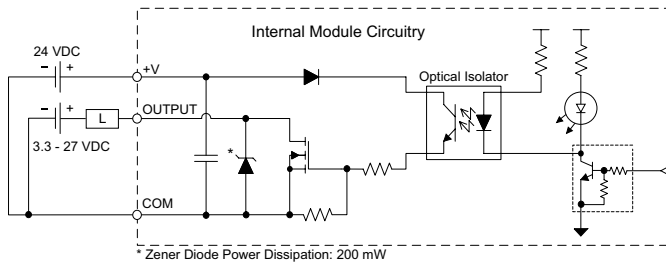

Z/PLink Pre-Wired PLC Connection Cables and Modules for CLICK PLC

11-pin connector cable
 ZL-C0-CBL11 (0.5 m length)
 ZL-C0-CBL11-1 (1.0 m length)
 ZL-C0-CBL11-2 (2.0 m length)



Output Module Temperature Derating Chart

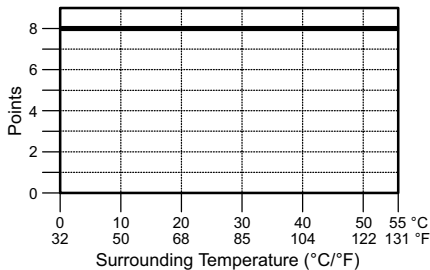

ZL-RTB20
 20-pin feed-through
 connector module



C0-08TD2 – 8-Point Sourcing DC Output Module

8-point 12–24VDC current sourcing output module, 1 common, 0.3 A/pt, removable terminal block included.

Wiring Diagram

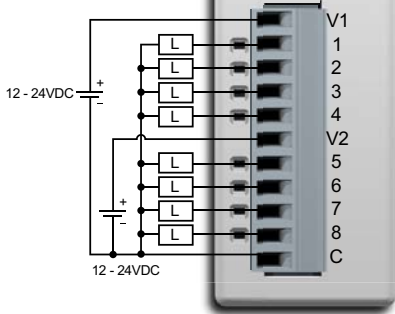

Output Specifications	
Outputs per Module	8 (Source)
Operating Voltage Range	12–24VDC
Output Voltage Range	9.6–30 VDC
Maximum Output Current	0.3 A/point, 1.2 A/common
Minimum Output Current	0.5 mA
Maximum Leakage Current	0.1 mA @ 30.0 VDC
On Voltage Drop	1.5 VDC @ 0.3 A
Maximum Inrush Current	1A for 10ms
OFF to ON Response	< 1ms
ON to OFF Response	< 1ms
Status Indicators	Logic Side (8 points, red LED) Power Indicator (green LED)
Commons	1 (8 points/common)
Bus Power Required (24VDC)	Max. 50mA (All Outputs On)
Terminal Block Replacement	AutomationDirect p/n C0-8TB
Weight	2.8 oz (80g)

Equivalent Output Circuit

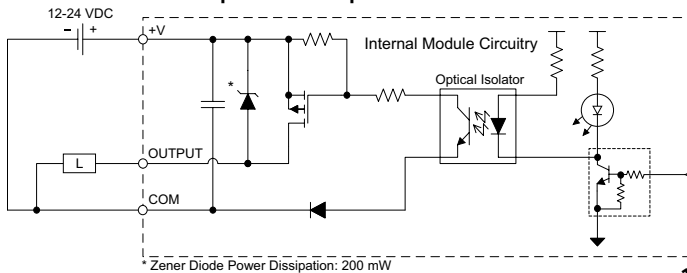

Z/PLink Pre-Wired PLC Connection Cables and Modules for CLICK PLC



- 11-pin connector cable
- ZL-C0-CBL11 (0.5 m length)
- ZL-C0-CBL11-1 (1.0 m length)
- ZL-C0-CBL11-2 (2.0 m length)

Output Module Temperature Derating Chart

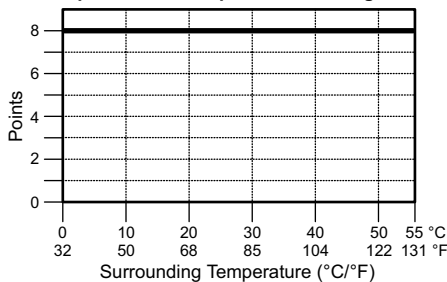

ZL-RTB20
20-pin feed-through
connector module



Chapter 2: Specifications

C0-16TD1 – 16-Point Sinking DC Output Module

16-point 5–27 VDC current sinking output module, 2 commons, isolated, 0.1 A/pt, removable terminal block included.

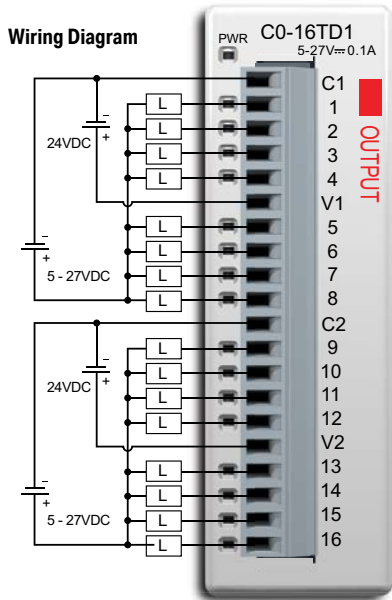

Output Specifications	
Outputs per Module	16 (Sink)
Operating Voltage Range	5–27 VDC
Output Voltage Range	4–30 VDC
Maximum Output Current	0.1 A/point, 0.8 A/common
Minimum Output Current	0.2 mA
Maximum Leakage Current	0.1 mA @ 30.0 VDC
On Voltage Drop	0.5 VDC @ 0.1 A
Maximum Inrush Current	150mA for 10ms
OFF to ON Response	< 0.5 ms
ON to OFF Response	< 0.5 ms
Status Indicators	Logic Side (16 points, red LED) Power Indicator (green LED)
Commons	2 (8 Points/common) Isolated
External DC Power Required	21.6 – 26.4 VDC Max 100mA (All Outputs On)
Bus Power Required (24VDC)	Max. 80mA (All Outputs On)
Terminal Block Replacement	AutomationDirect p/n C0-16TB
Weight	3.2 oz (90g)

Equivalent Output Circuit

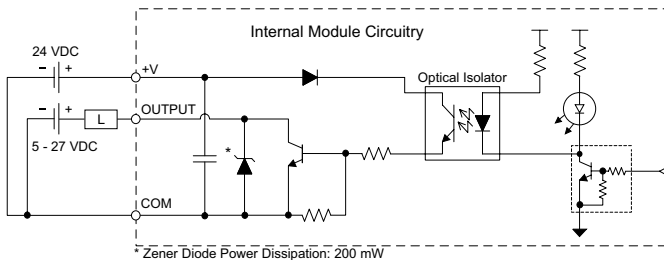

Z/PLink Pre-Wired PLC Connection Cables and Modules for CLICK PLC



20-pin connector cable
 ZL-C0-CBL20 (0.5 m length)
 ZL-C0-CBL20-1 (1.0 m length)
 ZL-C0-CBL20-2 (2.0 m length)

Output Module Temperature Derating Chart

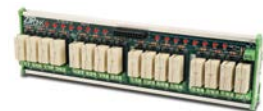
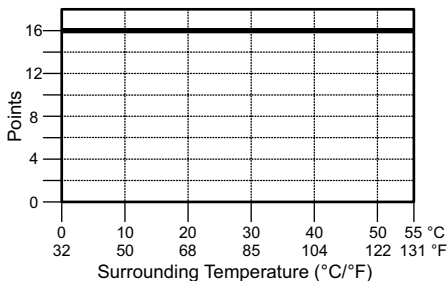

Note: 10A/Point (DC)
 8A/Point (AC)
 (Replaceable relays)

C0-16TD2 – 16-Point Sourcing Output Module

16-point 12–24 VDC current sourcing output module, 2 commons, isolated, 0.1 A/pt, removable terminal block included.

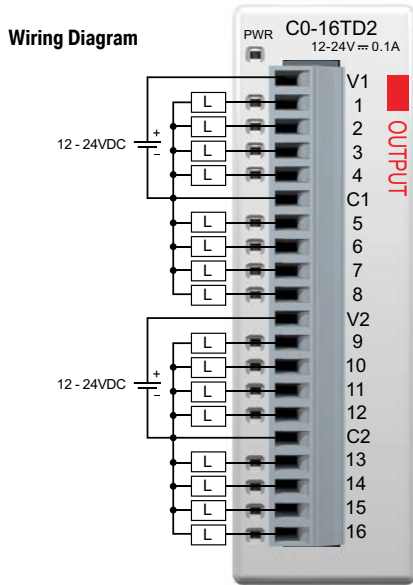

Output Specifications	
Outputs per Module	16 (Source)
Operating Voltage Range	12-24VDC
Output Voltage Range	9.6 – 30.0 VDC
Maximum Output Current	0.1 A/point , 0.8 A/common
Minimum Output Current	0.2 mA
Maximum Leakage Current	0.1 mA @ 30.0 VDC
On Voltage Drop	0.6 VDC @ 0.1 A
Maximum Inrush Current	150mA for 10ms
OFF to ON Response	< 0.5 ms
ON to OFF Response	< 0.5 ms
Status Indicators	Logic Side (16 points, red LED) Power Indicator (green LED)
Commons	2 (8 points/common) Isolated
Bus Power Required (24VDC)	Max. 80mA (All Outputs On)
Terminal Block Replacement	AutomationDirect p/n C0-16TB
Weight	3.2 oz (90g)

Equivalent Output Circuit

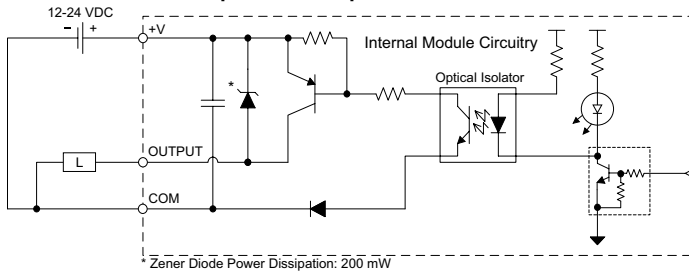

ZIPLink Pre-Wired PLC Connection Cables and Modules for CLICK PLC



- 20-pin connector cable
- ZL-C0-CBL20 (0.5 m length)
- ZL-C0-CBL20-1 (1.0 m length)
- ZL-C0-CBL20-2 (2.0 m length)

Output Module Temperature Derating Chart

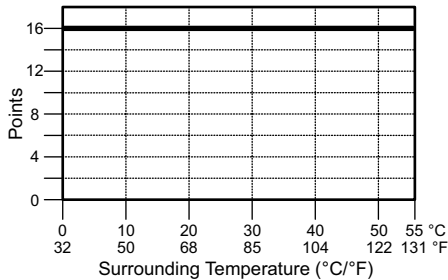

Chapter 2: Specifications

C0-08TA – 8-Point AC Output Module

8-point 17-240 VAC triac output module, 2 commons, isolated, 0.3 A/pt, removable terminal block included.

Wiring Diagram

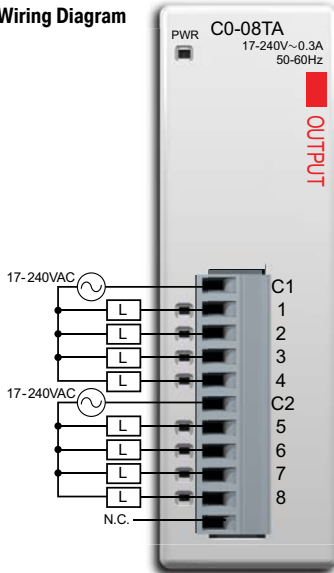

N.C. = Not Connected

Output Specifications

Outputs per Module	8
Operating Voltage Range	17-240 VAC
Output Voltage Range	13.5-288 VAC
AC Frequency	47-63 Hz
Maximum Output Current	0.3 A/point, 1.2 A/common
Minimum Load	10mA
Maximum Leakage Current	4mA @ 288 VAC
On Voltage Drop	1.5 VAC @ > 0.1 A 3.0 VAC @ < 0.1 A
Maximum Inrush Current	10A for 10ms
OFF to ON Response	1ms
ON to OFF Response	1ms + 1/2 cycle
Status Indicators	Logic Side (8 points, red LED) Power Indicator (green LED)
Commons	2 (4 points/common) Isolated
Bus Power Required (24VDC)	Max. 80mA (All Outputs On)
Protection Circuit	Not built into the module - Install protection elements such as external fuse.
Terminal Block Replacement	AutomationDirect p/n C0-8TB
Weight	3.5 oz (100g)

Equivalent Output Circuit

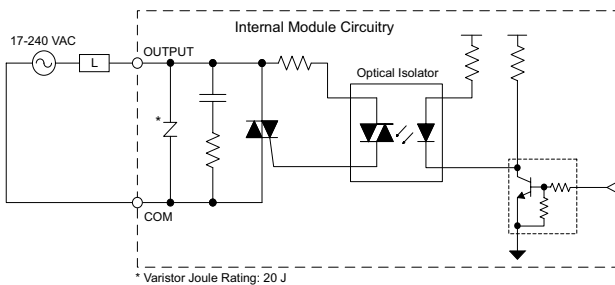

Z/PLink Pre-Wired PLC Connection Cables and Modules for CLICK PLC



11-pin connector cable
 ZL-C0-CBL11 (0.5 m length)
 ZL-C0-CBL11-1 (1.0 m length)
 ZL-C0-CBL11-2 (2.0 m length)

Output Temperature Derating Chart

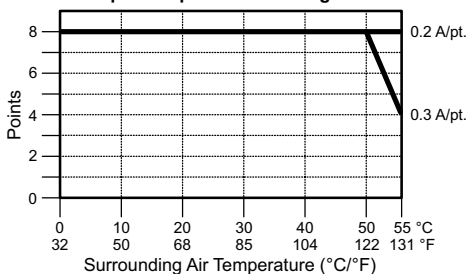

* Use every other output.

ZL-RTB20
 20-pin feed-through
 connector module



CO-04TRS – 4-Point Relay Output Module

4-point 6–240 VAC / 6–27VDC Isolated relay output module, 4 Form C (SPDT) relays, 4 isolated commons, 7 A/point, removable terminal block included.

Wiring Diagram

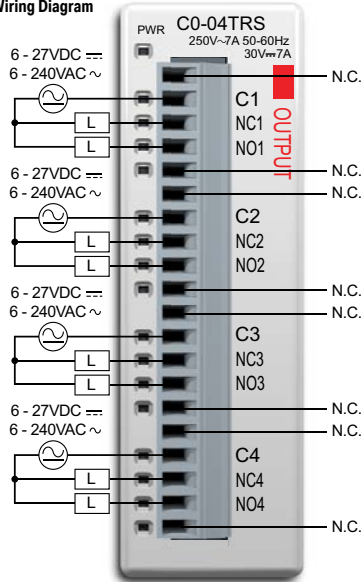

N.C. = Not Connected

Output Specifications	
Outputs per Module	4
Operating Voltage Range	6–27 VDC / 6–240 VAC
Output Voltage Range	5–30 VDC / 5–264 VAC
Output Type	Relay, form C (SPDT)
AC Frequency	47–63 Hz
Maximum Current	7A / point, 7A / common
Minimum Load Current	100mA @ 5VDC
Maximum Leakage Current	0.1 mA @ 264VAC
Maximum Inrush Current	12A
OFF to ON Response	< 15ms
ON to OFF Response	< 15ms
Status Indicators	Logic Side (4 points, red LED) Power Indicator (green LED)
Commons	4 (1 point/common) Isolated
Bus Power Required (24VDC)	Max. 100mA (All Outputs On)
Protection Circuit	Not built into the module - Install protection elements such as external fuse.
Terminal Block Replacement	AutomationDirect p/n CO-16TB
Weight	4.4 oz (125g)

Equivalent Output Circuit

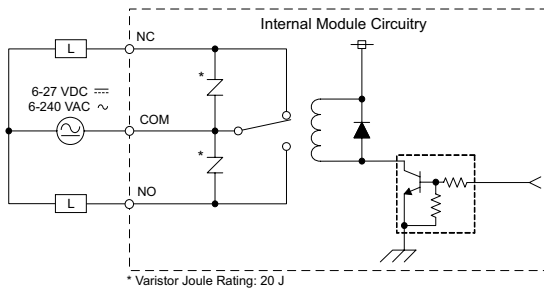

Typical Relay Life (Operations) at Room Temperature	
Voltage & Load Type	Relay Life
30VDC, 7A Resistive	100,000 cycles
250VAC, 7A Resistive	100,000 cycles
250VAC, 4.9 A Solenoid	90,000 cycles
250VAC, 2.9 A Solenoid	100,000 cycles
ON to OFF = 1 cycle	

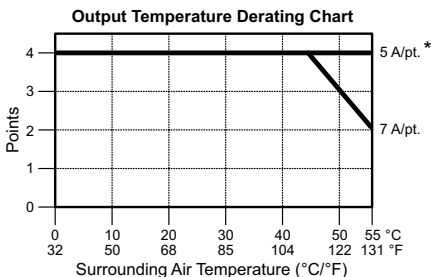

* No derating when the load current is 5A or less for each output point.



NOTE: The CO-04TRS relay output module is derated to 2A per point maximum when used with the ZIPLink wiring system.

ZIPLink Pre-Wired PLC Connection Cables and Modules for CLICK PLC



20-pin connector cable
ZL-C0-CBL20 (0.5 m length)
ZL-C0-CBL20-1 (1.0 m length)
ZL-C0-CBL20-2 (2.0 m length)

ZL-RTB20
 20-pin feed-through connector module

Chapter 2: Specifications

C0-04TRS-10 – 4-Point Relay Output Module

4-point 6–240 VAC / 6–24VDC Isolated relay output module, 4 Form A (SPST) relays, 4 isolated commons, 10A/point, removable terminal block included.

Wiring Diagram

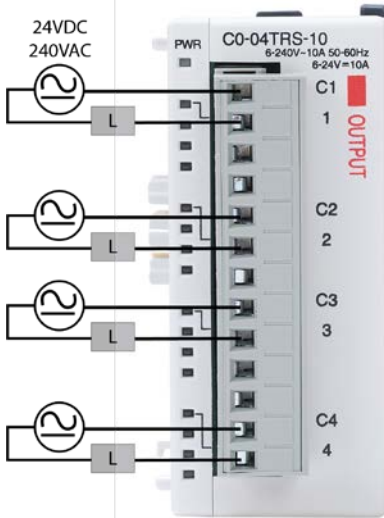

Output Specifications

Outputs per Module	4
Operating Voltage Range	6–24 VDC / 6–240 VAC
Peak Voltage	24VDC / 264VAC
Output Type	Relay, form A (SPST)
AC Frequency	47–63 Hz
Maximum Current	10A / point, 10A / common
Minimum Load Current	100mA @ 5VDC
Maximum Inrush Current	16A for 10ms
OFF to ON Response	< 15ms
ON to OFF Response	< 15ms
Status Indicators	Logic Side (4 points, red LED) Power Indicator (green LED)
Commons	4 (1 point/common) Isolated
Bus Power Required (24VDC)	Max. 120mA (All Outputs On)
Protection Circuit	Not built into the module - Install protection elements such as external fuse.
Terminal Block Replacement	AutomationDirect p/n C0-8TB-1
Weight	5.22 oz (148g)

Typical Relay Life (Operations) at Room Temperature

Voltage & Load Type	Relay Life
24VDC, 10A Resistive	120,000 cycles
24VDC, 10A Inductive	60,000 cycles
110VAC, 10A Resistive	120,000 cycles
110VAC, 10A Inductive	35,000 cycles
220VAC, 10A Resistive	120,000 cycles
220VAC, 10A Inductive	35,000 cycles

ON to OFF = 1 cycle

Output Temperature Derating Chart

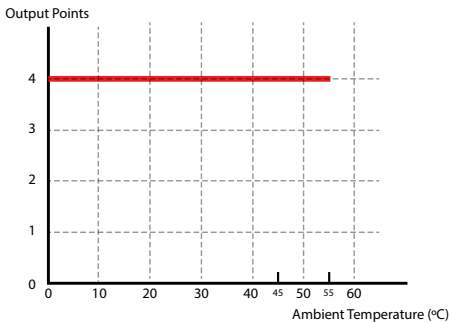

Equivalent Output Circuit

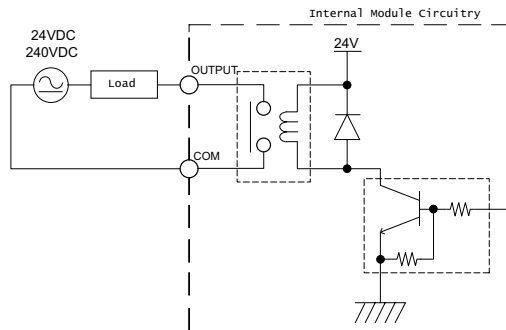

C0-08TR – 8-Point Relay Output Module

8-point 6–240 VAC /6–27 VDC relay output module, 8 Form A (SPST) relays, 2 commons, isolated, 4 A/common, removable terminal block included.

Wiring Diagram

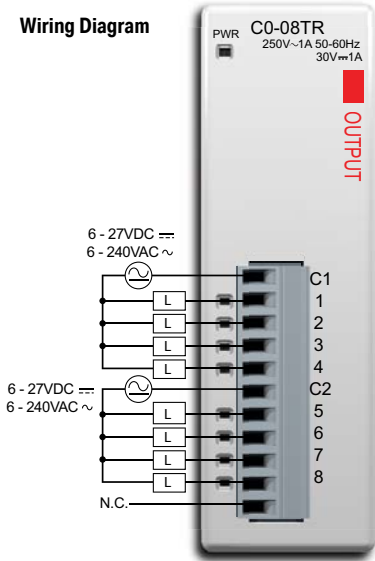

N.C. = Not Connected

Output Specifications	
Outputs per Module	8
Operating Voltage Range	6-27 VDC / 6-240 VAC
Output Voltage Range	5-30 VDC / 5-264 VAC
Output Type	Relay, form A (SPST)
AC Frequency	47-63 Hz
Maximum Current (resistive)	1A /point, 4A /common
Minimum Load Current	5mA @ 5VDC
Maximum Leakage Current	0.1 mA @ 264VAC
Maximum Inrush Current	3A for 10ms
OFF to ON Response	< 15ms
ON to OFF Response	< 15ms
Status Indicators	Logic Side (8 points, red LED) Power Indicator (green LED)
Commons	2 (4 points/common) Isolated
Bus Power Required (24VDC)	Max. 100mA (All Outputs On)
Protection Circuit	Not built into the module - Install protection elements such as external fuse.
Terminal Block Replacement	AutomationDirect p/n C0-8TB
Weight	3.9 oz (110g)

Equivalent Output Circuit

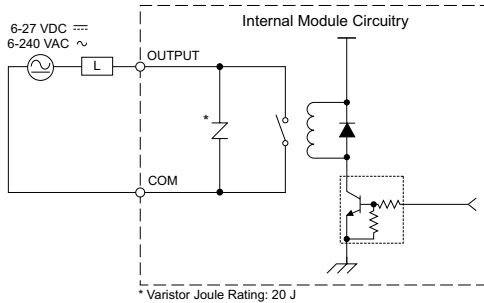

Typical Relay Life (Operations) at Room Temperature	
Voltage & Load Type	Relay Life
30VDC, 1A Resistive	300,000 cycles
30VDC, 1A Solenoid	50,000 cycles
250VAC, 1A Resistive	500,000 cycles
250VAC, 1A Solenoid	200,000 cycles
ON to OFF = 1 cycle	

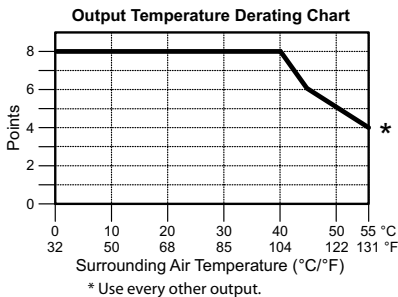

ZIPLink Pre-Wired PLC Connection Cables and Modules for CLICK PLC



- 11-pin connector cable
- ZL-C0-CBL11 (0.5 m length)
- ZL-C0-CBL11-1 (1.0 m length)
- ZL-C0-CBL11-2 (2.0 m length)



ZL-RTB20
20-pin feed-through
connector module



NOTE: The C0-08TR is derated to 2A maximum per Common when used with the ZIPLink wiring system.

Chapter 2: Specifications

C0-08TR-3 – 8-Point Relay Output Module

8-point 6–240 VAC /6–27 VDC relay output module, 8 Form A (SPST) relays, 4 commons, isolated, 3A/point, removable terminal block included.

Wiring Diagram

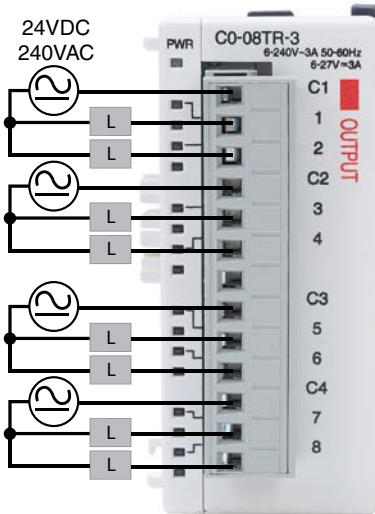

Output Specifications

Outputs per Module	8
Operating Voltage Range	6–27 VDC / 6–240 VAC
Peak Voltage	30 VDC / 264 VAC
Output Type	Relay, form A (SPST)
AC Frequency	47–63 Hz
Maximum Current (resistive)	3A /point, 6A /common
Minimum Load Current	5mA @ 5VDC
Maximum Inrush Current	5A for 10ms
OFF to ON Response	< 15ms
ON to OFF Response	< 15ms
Status Indicators	Logic Side (8 points, red LED) Power Indicator (green LED)
Commons	4 (2 points/common) Isolated
Bus Power Required (24VDC)	Max. 90mA (All Outputs ON)
Protection Circuit	Not built into the module - Install protection elements such as external fuse.
Terminal Block Replacement	AutomationDirect p/n C0-8TB-1
Weight	4.12 oz (117g)

Typical Relay Life (Operations) at Room Temperature

Voltage & Load Type	Relay Life
24VDC, 3A Resistive	100,000 cycles
24VDC, 3A Inductive	50,000 cycles
110VAC, 3A Resistive	100,000 cycles
110VAC, 3A Inductive	25,000 cycles
220VAC, 3A Resistive	100,000 cycles
220VAC, 3A Inductive	25,000 cycles

ON to OFF = 1 cycle

Output Temperature Derating Chart

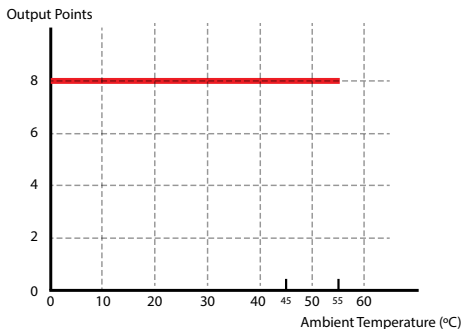

Equivalent Output Circuit

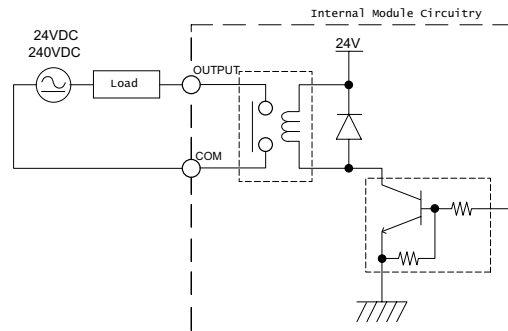

C0-16CDD1 – 8-Point DC Input and 8-Point DC Sinking Output Module

8-point 24VDC current sinking/sourcing input, 1 common, 8-point 5–27 VDC sinking output, 0.1A/pt., 1 common, non-fused, removable terminal block included.

Wiring Diagram

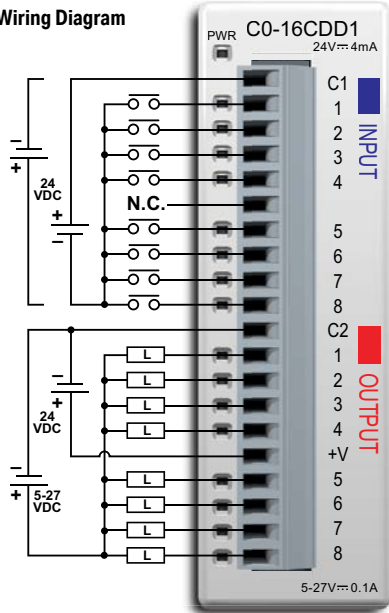

N.C. = Not Connected

Input Specifications	
Inputs per Module	8 (Source/Sink)
Operating Voltage Range	CE: 24VDC (-10%/+10%) UL: 24VDC (-10%/+10%)
Input Voltage Range	21.6 – 26.4 VDC
Input Current	Typ 4.0 mA @ 24VDC
Maximum Input Current	5.0 mA @ 26.4 VDC
Input Impedance	6.8 kΩ @ 24VDC
ON Voltage Level	>19.0 VDC
OFF Voltage Level	<7.0 VDC
Minimum ON Current	3.5 mA
Maximum OFF Current	0.5 mA
OFF to ON Response	Max. 10ms Typ 2ms
ON to OFF Response	Max. 10ms Typ 3ms
Status Indicators	Logic Side (8 points, green LED) Power Indicator (green LED)
Commons	1 (8 points/common)

General Specifications	
Bus Power Required (24VDC)	Max. 80mA (all points on)
Terminal Block Replacement	AutomationDirect p/n C0-16TB
Weight	3.2 oz (90g)



NOTE: When using this module you must also use CLICK programming software and PLC firmware version V1.40 or later.

Equivalent Input Circuit

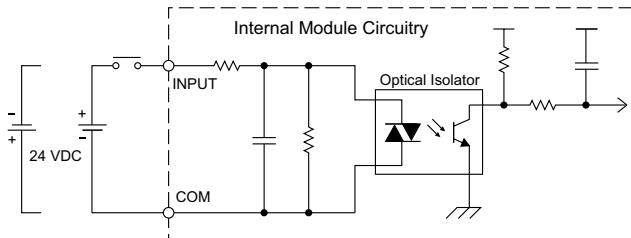

Input Module Temperature Derating Chart

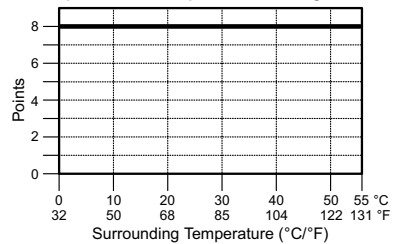

C0-16CDD1 (continued)

Output Specifications	
Outputs per Module	8 (sink)
Operating Voltage Range	CE: 5-24 VDC (-15%/+20%)
	UL: 5-27 VDC (-15%/+20%)
Output Voltage Range	4-30 VDC
Maximum Output Current	0.1 A/point, 0.8 A/common
Minimum Output Current	0.2 mA
Maximum Leakage Current	0.1 mA @ 30VDC
On Voltage Drop	0.5 VDC @ 0.1 A
Maximum Inrush Current	0.15 A for 10ms
OFF to ON Response	< 0.5 ms
ON to OFF Response	< 0.5 ms
Status Indicators	Logic Side (8 points, red LED)
Commons	1 (8 points/common)
External DC Power Required	24VDC (-10%/+10%) max. 50mA (all points on)

Equivalent Output Circuit

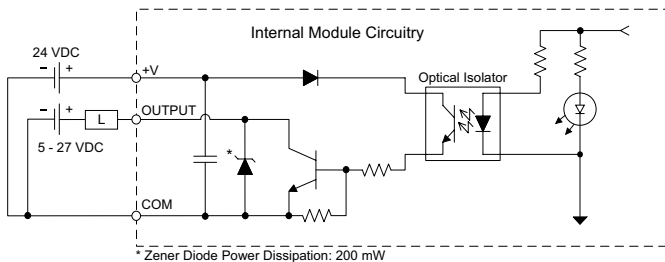

Output Module Temperature Derating Chart

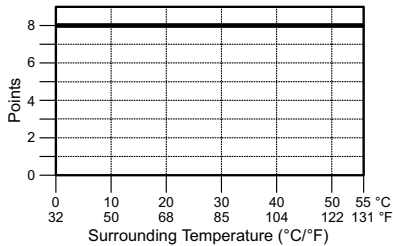

ZIPLink Pre-Wired PLC Connection Cables and Modules for CLICK PLC



ZL-RTB20
20-pin feed-through connector module

- 20-pin connector cable ZL-C0-CBL20 (0.5 m length)
- ZL-C0-CBL20-1 (1.0 m length)
- ZL-C0-CBL20-2 (2.0 m length)



C0-16CDD2 – 8-Point DC Input and 8-Point DC Sourcing Output Module

8-point 24VDC current sinking/sourcing input, 1 common, 8-point 12–24 VDC sourcing output, 0.1A/pt, 1 common, non-fused, removable terminal block included.

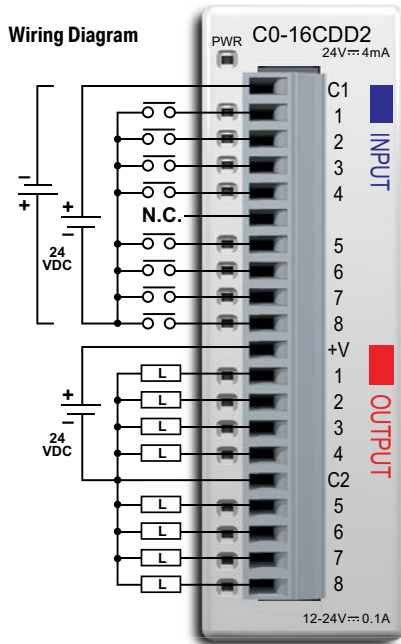

N.C. = Not Connected

Input Specifications	
Inputs per Module	8 (source/sink)
Operating Voltage Range	CE: 24VDC (-10%/+10%) UL: 24VDC (-10%/+10%)
Input Voltage Range	21.6 – 26.4 VDC
Input Current	Typ 4.0 mA @ 24VDC
Maximum Input Current	5.0 mA @ 26.4 VDC
Input Impedance	6.8 kΩ @ 24VDC
ON Voltage Level	>19.0 VDC
OFF Voltage Level	<7.0 VDC
Minimum ON Current	3.5 mA
Maximum OFF Current	0.5 mA
OFF to ON Response	Max. 10ms Typ 2ms
ON to OFF Response	Max. 10ms Typ 3ms
Status Indicators	Logic Side (8 points, green LED) Power Indicator (green LED)
Commons	1 (8 points/common)

General Specifications	
Bus Power Required (24VDC)	Max. 80mA (all points on)
Terminal Block Replacement	AutomationDirect p/n C0-16TB
Weight	3.2 oz (90g)



NOTE: When using this module you must also use CLICK programming software and PLC firmware version V1.40 or later.

Equivalent Input Circuit

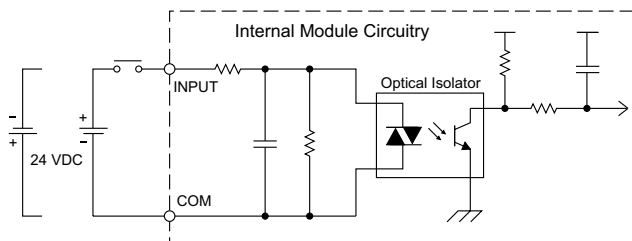

Input Module Temperature Derating Chart

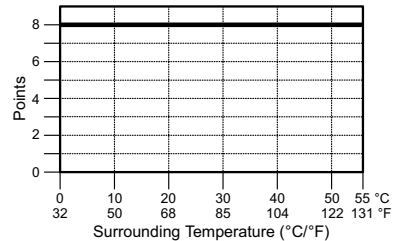

C0-16CDD2 (continued)

Output Specifications	
Outputs per Module	8 (Source)
Operating Voltage Range	CE: 12–24 VDC (-15%/+20%) UL: 12–24 VDC (-20%/+25%)
Output Voltage Range	9.6–30 VDC
Maximum Output Current	0.1 A/point, 0.8 A/common
Minimum Output Current	0.2 mA
Maximum Leakage Current	0.1 mA @ 30VDC
On Voltage Drop	0.6 VDC @ 0.1 A
Maximum Inrush Current	0.15 A for 10ms
OFF to ON Response	<0.5 ms
ON to OFF Response	<0.5 ms
Status Indicators	Logic Side (8 points, red LED)
Commons	1 (8 points/common)

Equivalent Output Circuit

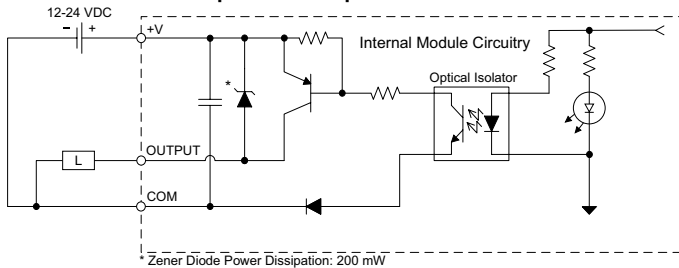

Output Module Temperature Derating Chart

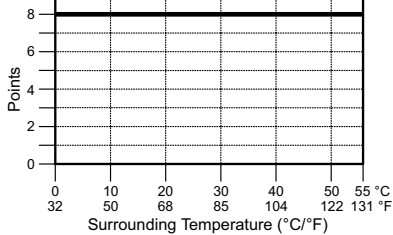

ZIPLink Pre-Wired PLC Connection Cables and Modules for CLICK PLC



ZL-RTB20
20-pin feed-through connector module

20-pin connector cable
ZL-C0-CBL20 (0.5 m length)
ZL-C0-CBL20-1 (1.0 m length)
ZL-C0-CBL20-2 (2.0 m length)



C0-08CDR – 4-Point DC Input and 4-Point Relay Output Module

4-point 12–24 VDC current sinking/sourcing input, 1 common, 4-point 6.25–24 VDC / 6–240 VAC relay output, Form A (SPST) relays 1A/pt, 1 common, non-fused, removable terminal block included.

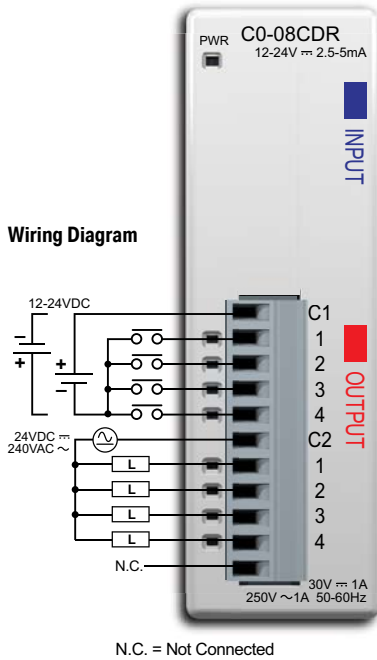

Input Specifications	
Inputs per Module	4 (source/sink)
Operating Voltage Range	CE: 12–24 VDC (-10%/+10%) UL: 12–24 VDC (-10%/+10%)
Input Voltage Range	10.8 – 26.4 VDC
Input Current	Typ 5.0 mA @ 24VDC
Maximum Input Current	7.0 mA @ 26.4 VDC
Input Impedance	4.7 kΩ @ 24VDC
ON Voltage Level	>8.0 VDC
OFF Voltage Level	<3.0 VDC
Minimum ON Current	1.4 mA
Maximum OFF Current	0.5 mA
OFF to ON Response	Max. 3.5 ms Typ 2ms
ON to OFF Response	Max. 4ms Typ 2.5 ms
Status Indicators	Logic Side (4 points, green LED) Power Indicator (green LED)
Commons	1 (4 points/common)

General Specifications	
Bus Power Required (24VDC)	Max. 80mA (all points on)
Protection Circuit	Not built into the module - Install protection elements such as external fuse
Terminal Block Replacement	AutomationDirect p/n C0-8TB
Weight	3.2 oz (90g)



NOTE: When using this module you must also use CLICK programming software and PLC firmware version V1.40 or later.

Equivalent Input Circuit

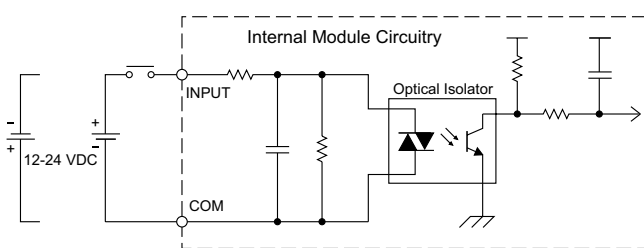

Input Temperature Derating Chart

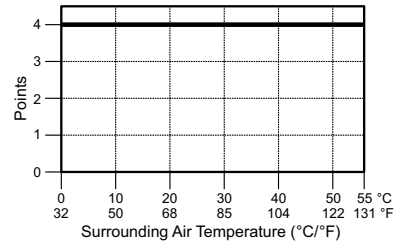

C0-08CDR (continued)

Output Specifications	
Outputs per Module	4 (Relay)
Operating Voltage Range	CE: 6.25–24 VDC (-15%/+10%) / 6–240 VAC (-15%/+10%) UL: 24VDC (-15%/+10%) / 240VAC (-10%/+10%)
Peak Voltage	30VDC / 264VAC
Output Type	Relay, Form A (SPST)
AC Frequency	47–63 Hz
Maximum Current	1A /point, 4 A/common
Minimum Load Current	5mA @ 5VDC
Maximum Leakage Current	0.1 mA @ 264VAC
Maximum Inrush Current	3A for 10ms
OFF to ON Response	<15ms
ON to OFF Response	<15ms
Status Indicators	Logic Side (4 points, red LED)
Commons	1 (4 points/common)

Typical Relay Life (Operations) at Room Temperature	
Voltage & Load Type*	Relay Life (ON to OFF = 1 cycle)
30VDC, 1A, Resistive	80,000 cycles
30VDC, 1A, Solenoid	80,000 cycles
250VAC, 1A, Resistive	80,000 cycles
250VAC, 1A, Solenoid	80,000 cycles

* These relay outputs support both inductive (solenoid) and resistive loads.

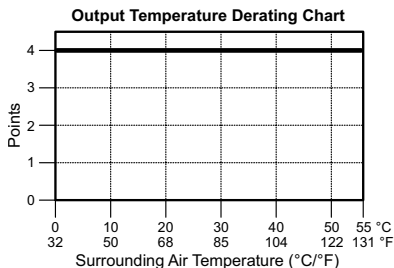
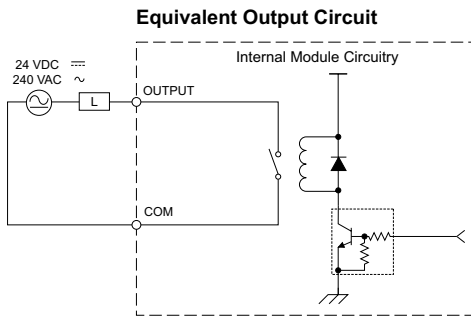

ZIPLink Pre-Wired PLC Connection Cables and Modules for CLICK PLC



ZL-RTB20
20-pin feed-through connector module

11-pin connector cable
 ZL-C0-CBL11 (0.5 m length)
 ZL-C0-CBL11-1 (1.0 m length)
 ZL-C0-CBL11-2 (2.0 m length)



C0-04AD-1 – 4-Channel Analog Current Input Module

4-channel analog current sinking input module, 13-bit resolution, range: 0–20 mA. External 24VDC power required, removable terminal block included.

Wiring Diagram

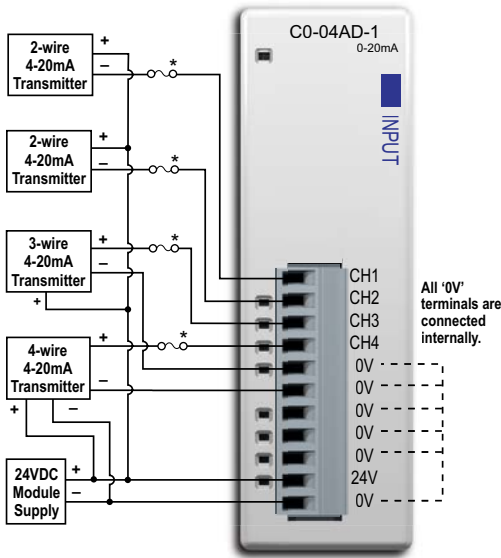

NOTE: When using this module you must also use CLICK programming software and PLC firmware version V1.40 or later.

Input Specifications	
Inputs per Module	4
Input Range	0–20 mA (sink)
Resolution	13-bit, 2.44 $\mu\text{A}/\text{count}$
Input Type	Single ended (one common)
Maximum Continuous Overload	$\pm 44\text{mA}$
Input Impedance	124 Ω , 0.5 W current input
Filter Characteristics	Low pass, -3 dB at 120Hz
Sample Duration Time	2ms
All Channel Update Rate	25ms
Open Circuit Detection Time	Zero reading within 100ms
Accuracy vs. Temperature	$\pm 75 \text{ PPM}/^\circ\text{C}$ maximum
Maximum Inaccuracy	0.5% of range (including temperature changes)
Linearity Error (End to End)	± 3 count maximum, monotonic with no missing codes
Input Stability and Repeatability	± 2 count maximum
Full Scale Calibration Error (including Offset)	± 8 count maximum
Offset Calibration Error	± 8 count maximum
Maximum Crosstalk at DC, 50/60 Hz	± 2 count maximum
Field to Logic Side Isolation	1800VAC for 1 sec.
Recommended Fuse (external)	AutomationDirect p/n S500-32-R (0.032A fuse)
External 24VDC Power Required	65mA
Bus Power Required (24VDC)	20mA
Terminal Block Replacement	AutomationDirect p/n C0-8TB
Weight	2.9 oz (82g)

Z/PLink Pre-Wired PLC Connection Cables and Modules for CLICK PLC



ZL-RTB20 20-pin feed-through connector module



11-pin connector cable
 ZL-C0-CBL11 (0.5 m length)
 ZL-C0-CBL11-1 (1.0 m length)
 ZL-C0-CBL11-2 (2.0 m length)

Chapter 2: Specifications

C0-04AD-2 – 4-Channel Analog Voltage Input Module

4-channel analog voltage input module, 13-bit resolution, range: 0–10V. External 24VDC power required, removable terminal block included.

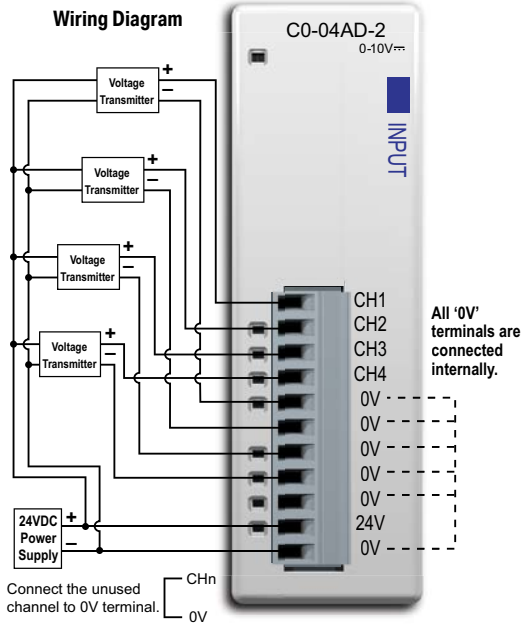

Input Specifications	
Inputs per Module	4
Input Range	0–10 V
Resolution	13-bit, 1.22 mV per count
Input Type	Single ended (one common)
Maximum Continuous Overload	±100VDC
Input Impedance	>150kΩ
Filter Characteristics	Low pass, -3 dB at 500Hz
Sample Duration Time	6.25 ms
All Channel Update Rate	25ms
Open Circuit Detection Time	Zero reading within 100 ms
Accuracy vs. Temperature	±75 PPM/°C maximum
Maximum Inaccuracy	0.5% of range (including temperature changes)
Linearity Error (End to End)	±3 count maximum, monotonic with no missing codes
Input Stability and Repeatability	±2 count maximum
Full Scale Calibration Error (Including Offset)	±8 count maximum
Offset Calibration Error	±8 count maximum
Maximum Crosstalk at DC, 50/60 Hz	±2 count maximum
Field to Logic Side Isolation	1800VAC for 1 sec.
External 24VDC Power Required	65mA
Base Power Required (24VDC)	23mA
Terminal Block Replacement	AutomationDirect p/n C0-8TB
Weight	2.9 oz (82g)



NOTE: When using this module you must also use CLICK programming software and PLC firmware version V1.40 or later.

ZIPLink Pre-Wired PLC Connection Cables and Modules for CLICK PLC



ZL-RTB20 20-pin feed-through connector module

11-pin connector cable
 ZL-C0-CBL11 (0.5 m length)
 ZL-C0-CBL11-1 (1.0 m length)
 ZL-C0-CBL11-2 (2.0 m length)



C0-04RTD – 4-Channel RTD Input Module

4-channel RTD input module, 16-bit resolution (± 0.1 degrees Celsius or Fahrenheit), supports: Pt100, Pt1000, jPT100, Cu10, Cu25, Ni120. Resistive ranges also supported, removable terminal block included.

Wiring Diagram

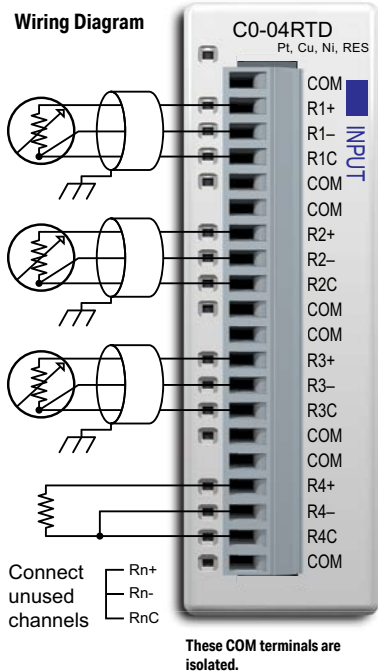

Connect unused channels
 Rn+
 Rn-
 RnC

These COM terminals are isolated.



NOTE: The C0-04RTD module cannot be used with thermistors.



NOTE: When using this module you must also use CLICK programming software and PLC firmware version V1.40 or later.

If there are any unused channels, make sure to select the correct number of channels that you actually use in the C0-04RTD Setting window.

General Specifications	
Field to Logic Side Isolation	No isolation
External DC Power Required	None
Bus Power Required (24VDC)	25mA
Thermal Dissipation	2.047 BTU per hour
Terminal Block Replacement	AutomationDirect p/n C0-16TB
Weight	3.1 oz (86g)

Input Specifications	
Inputs per Module	4
Common Mode Range	± 2.5 V
Common Mode Rejection	100dB at DC and 100 dB at 50/60 Hz
Input Impedance	$> 5M\Omega$
Maximum Ratings	Fault protected inputs to $\pm 50VDC$
Resolution	$\pm 0.1^\circ C$ or $^\circ F$, 0.1 Ω or 0.01 Ω
Input Ranges*	Pt100: -200 to 850°C (-328 to 1562°F)
	Pt1000: -200 to 595°C (-328 to 1103°F)
	jPt100: -100 to 450°C (-148 to 842°F)
	10 Ω Cu: -200 to 260°C (-328 to 500°F)
	25 Ω Cu: -200 to 260°C (-328 to 500°F)
	120 Ω Ni: -80 to 260°C (-112 to 500°F)
	0 to 3125.0 Ω : Resolution 0.1 Ω
0 to 1562.5 Ω : Resolution 0.1 Ω	
0 to 781.2 Ω : Resolution 0.1 Ω	
0 to 390.62 Ω : Resolution 0.01 Ω	
0 to 195.31 Ω : Resolution 0.01 Ω	
RTD Linearization	Automatic
Excitation Current (All Ranges)	210 μA

* While it is possible to use different resistive ranges, we recommend using the narrowest range that covers the resistance being measured. For example, if measuring approximately 100 ohms resistance, use the 0 to 195.31 ohms range. While the resolution is the same as the 0 to 390.62 ohms range, output RMS noise will be lower and stability will be improved.

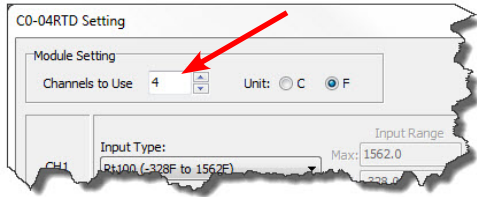

C0-04RTD – 4-Channel RTD Input Module (continued)

Input Specifications (continued)	
Accuracy vs. Temperature	±10ppm per °C maximum
RTD Input Maximum Inaccuracy	±3°C (excluding RTD error); ±5°C (ranges Cu10 and Cu25)
RTD Linearity Error (End to End)	±2°C maximum, ±0.5°C typical, monotonic with no missing codes
Resistance Input Maximum Zero Scale Error	±0.0015% of full scale range in ohms (negligible)
Resistance Input Maximum Full Scale Error	±0.02% of full scale range
Maximum Linearity Error	±0.015% of full scale range maximum at 25°C, monotonic with no missing codes
Resistance Maximum Input Inaccuracy	0.1% at 0 to 60°C (32° to 140° F), typical 0.04% at 25°C (77° F)
Warm Up Time	30 minutes for ±1°C repeatability
Single Channel Update Rate	240ms
All Channel Update Rate	Single Channel Update Rate times the number of enabled channels on the module
Open Circuit Detection Time	Positive full-scale reading within 2 seconds
Conversion Method	Sigma - Delta

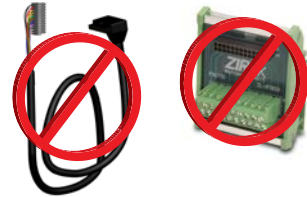

Not Compatible with ZIPLink Pre-Wired PLC Connection Cables and Modules.



NOTE: When this module is used in a CLICK PLC system, it takes up to 24 seconds for initialization after power-up. During this time period, the RUN LED on the PLC module blinks to indicate the initialization process.

Initialization Time		
The Number of Channels Used	The same Input Type is selected for all Channels	Mixed Input Types are selected
1	4 sec	N/A
2	5 sec	May take up to 13 sec
3	6 sec	May take up to 18 sec
4	7 sec	May take up to 24 sec

C0-04THM – 4-Channel Thermocouple Input Module

4-channel thermocouple input module, 16-bit resolution (± 0.1 degrees Celsius or Fahrenheit), Supports: J, K, E, R, S, T, B, N, C type thermocouples; voltages ranges also supported, removable terminal block included.

Wiring Diagram

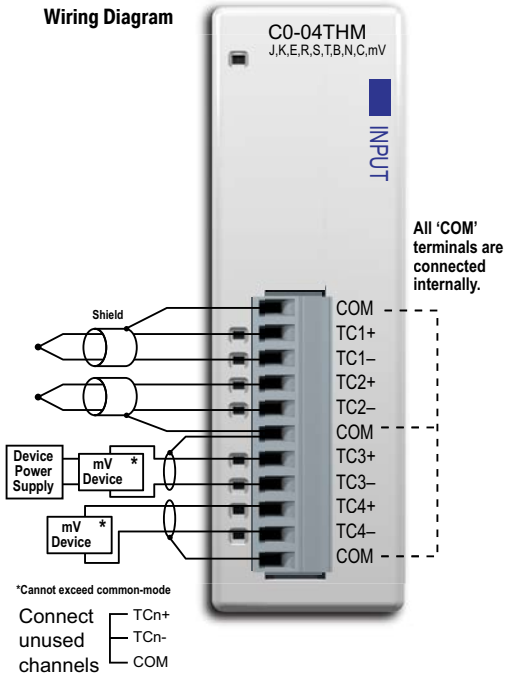

NOTE: When using this module you must also use CLICK programming software and PLC firmware version V1.40 or later.



General Specifications	
Field to Logic Side Isolation	1800 VAC applied for 1 second (100% tested)
External DC Power Required	None
Bus Power Required (24VDC)	25mA
Thermal Dissipation	0.175 BTU per hour
Terminal Block Replacement	AutomationDirect p/n C0-8TB
Weight	3.1 oz (86 g)

Input Specifications	
Inputs per Module	4
Common Mode Range	-1.3 to +3.8 V
Common Mode Rejection	100dB at DC and 130dB at 60Hz
Input Impedance	>5MΩ
Maximum Ratings	Fault protected inputs to ± 50 VDC
Resolution	$\pm 0.1^\circ\text{C}$ or $^\circ\text{F}$, 16-bit
Input Ranges	Type J: -190 to 760°C (-310 to 1400°F)
	Type K: -150 to 1372°C (-238 to 2502°F)
	Type E: -210 to 1000°C (-346 to 1832°F)
	Type S: 65 to 1768°C (149 to 3214°F)
	Type T: -230 to 400°C (-382 to 752°F)
	Type B: 529 to 1820°C (984 to 3308°F)
	Type N: -70 to 1300°C (-94 to 2372°F)
Type C: 65 to 2320°C (149 to 4208°F)	
	0 to 39.0625 mV
	± 39.0625 mV
	± 78.125 mV
	0 to 156.25 mV
	± 156.25 mV
	0 to 1.25 V

If there are any unused channels, make sure to select the correct number of channels that you actually use in the C0-04THM Setting window.

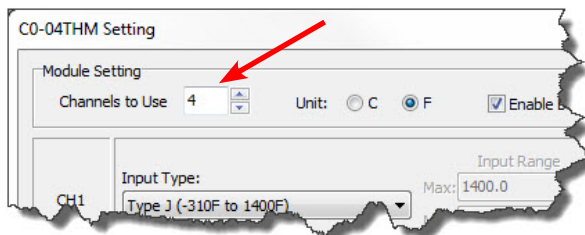

C0-04THM – 4-Channel Thermocouple Input Module (continued)

Input Specifications (continued)	
Cold Junction Compensation	Automatic
Thermocouple Linearization	Automatic
Accuracy vs. Temperature	±25 ppm per °C maximum
Linearity Error	±2°C maximum, ±1°C typical, monotonic with no missing codes
Maximum Inaccuracy	±3°C maximum (excluding thermocouple error)
Maximum Voltage Input Offset Error	0.05% at 0° to 55° C (32° to 131° F), typical 0.04% at 25° C (77° F)
Maximum Voltage Input Gain Error	0.06% at 25°C (77°F)
Maximum Voltage Input Linearity Error	0.05% at 0° to 55°C (32° to 131°F), typical 0.03% at 25°C (77°F)
Maximum Voltage Input Inaccuracy	0.1% at 0° to 55°C (32° to 131°F), typical 0.04% at 25°C (77°F)
Warm Up Time	30 minutes for ±1°C repeatability
Single Channel Update Rate	400ms
All Channel Update Rate	Single Channel Update Rate times the number of enabled channels on the module
Open Circuit Detection Time	Burn Out flag set and zero scale reading within 3 seconds
Conversion Method	Sigma - Delta

Not Compatible with ZIPLink Pre-Wired PLC Connection Cables and Modules.



NOTE: When this module is used in a CLICK PLC system, it takes up to 11 seconds for initialization after power-up. During this time period, the RUN LED on the PLC module blinks to indicate the initialization process.

Initialization Time	
The Number of Channels Used	With any Configuration
1	5 sec
2	7 sec
3	9 sec
4	11 sec



NOTE: With grounded thermocouples, take precautions to prevent having a voltage potential between thermocouple tips. A voltage less than -1.3V or greater than +3.8V between tips will skew measurements.

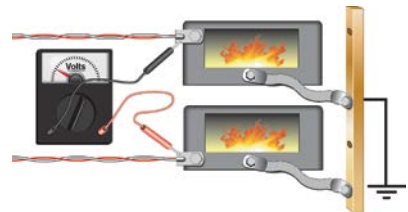

C0-04DA-1 – 4-Channel Analog Current Output Module

4-channel analog current sourcing output module, 12-bit resolution, range: 4–20 mA. External 24VDC power required, removable terminal block included.

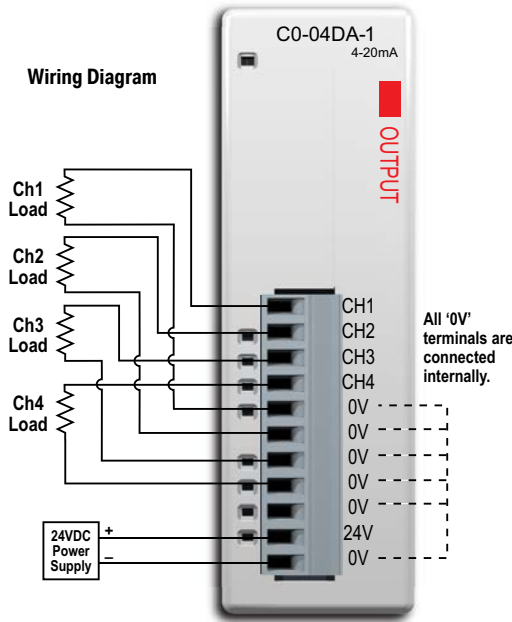

NOTE: When using this module you must also use CLICK programming software and PLC firmware version V1.40 or later.

Output Specifications	
Outputs per Module	4
Output Range	4–20 mA (source)
Resolution	12-bit, 3.9 uA per count
Output Type	Current sourcing at 20mA max.
Output Value in Fault Mode	Less than 4mA
Load Impedance	0–600Ω at 24VDC; minimum load: 0Ω 32° to 131°F (0° to 55°C) ambient temp.
Maximum Inductive Load	1mH
Allowed Load Type	Grounded
Maximum Inaccuracy	±1% of range
Max. Full Scale Calibration Error (Including Offset)	±0.2% of range maximum
Max. Offset Calibration Error	±0.2% of range maximum
Accuracy vs. Temperature	±75 PPM/°C maximum full scale calibration change (±0.005% of range/°C)
Max. Crosstalk at DC, 50/60 Hz	-72 dB, 1 LSB
Linearity Error (End to End)	±4 LSB max., (±0.1% of full scale)
Output Stability and Repeatability	±2% LSB after 10 minute warmup period typical
Output Ripple	±0.1% of full scale
Output Settling Time	0.3 ms maximum, 5μs min. (full scale range)
All Channel Update Rate	10ms
Max. Continuous Overload	Outputs open circuit protected 1800VAC applied for 1 second (100% tested)
Field to Logic Side Isolation	Electronically limited to 20mA or less
Type of Output Protection	Electronically limited to 20mA or less
Output Signal at Power Up and Power Down	4mA
External VDC Power Required	145mA
Base Power Required (24VDC)	20mA
Terminal Block Replacement	AutomationDirect p/n C0-8TB
Weight	2.9 oz (82g)

ZL-RTB20 20-pin feed-through connector module



Z/PLink Pre-Wired PLC Connection Cables and Modules for CLICK PLC

11-pin connector cable
 ZL-C0-CBL11 (0.5 m length)
 ZL-C0-CBL11-1 (1.0 m length)
 ZL-C0-CBL11-2 (2.0 m length)



C0-04DA-2 – 4-Channel Analog Voltage Output Module

4-channel analog voltage output module, 12-bit resolution, range: 0–10 V. External 24VDC power required, removable terminal block included.

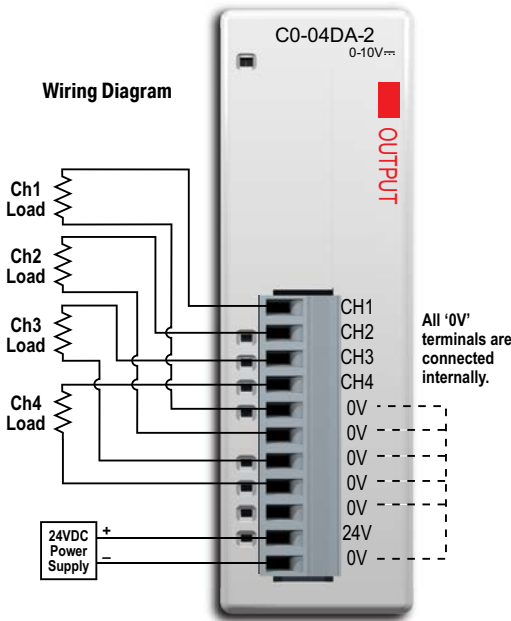

NOTE: When using this module you must also use CLICK programming software and PLC firmware version V1.40 or later.

ZIPLink Pre-Wired PLC Connection Cables and Modules for CLICK PLC

11-pin connector cable
 ZL-C0-CBL11 (0.5 m length)
 ZL-C0-CBL11-1 (1.0 m length)
 ZL-C0-CBL11-2 (2.0 m length)



ZL-RTB20 20-pin feed-through connector module



Output Specifications	
Outputs per Module	4
Output Range	0–10 V
Resolution	12-bit, 2.44 mV per count
Output Type	Voltage sourcing at 10mA max. (One common)
Output Value in Program Mode	Determined by PLC
Output Value in Fault Mode	0 V
Output Impedance	0.2 Ω typical
Load Impedance	>1000Ω
Maximum Capacitive Load	0.01 μF maximum
Allowed Load Type	Grounded
Maximum Inaccuracy	0.5% of range
Max. Full Scale Calibration Error (Not including Offset)	±0.2% of range maximum voltage
Max. Offset Calibration Error	±0.2% of range maximum
Accuracy vs. Temperature	±75 PPM/°C maximum full scale calibration change (±0.0025% of range/°C)
Max. Crosstalk at DC, 50/60 Hz	-72 dB, 1 LSB
Linearity Error (End to End)	±4 LSB max., (±0.1% of full scale); monotonic with no missing codes
Output Stability and Repeatability	±2% LSB after 10 minute warmup period typical
Output Ripple	0.1% of full scale
Output Settling Time	0.3 ms maximum, 5 μs minimum (full scale range)
All Channel Update Rate	10ms
Max. Continuous Overload	Outputs current limited to 40mA typical; continuous overloads on multiple outputs can damage module.
Field to Logic Side Isolation	1800VAC applied for 1 second (100% tested)
Type of Output Protection	0.1 μF transient suppressor
Output Signal at Power Up and Power Down	0 V
External 24VDC Power Required	85mA
Base Power Required (24VDC)	20mA
Terminal Block Replacement	AutomationDirect p/n C0-8TB
Weight	2.9 oz (82g)

C0-4AD2DA-1 – 4-Channel Analog Current Input and 2-Channel Analog Current Output Module

4-channel analog current sinking input (13-bit resolution) and 2-channel analog current sourcing output (12-bit resolution) module, range: 0–20 mA (inputs), 4–20 mA (outputs). External 24VDC power required, removable terminal block included.

Wiring Diagram

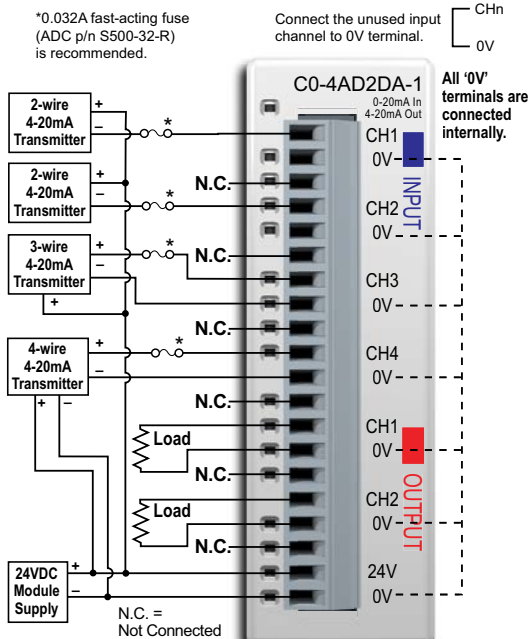

NOTE: When using this module you must also use *CLICK* programming software and PLC firmware version V1.40 or later.

ZIPLink Pre-Wired PLC Connection Cables and Modules for CLICK PLC

- 20-pin connector cable ZL-C0-CBL20 (0.5 m length)
- ZL-C0-CBL20-1 (1.0 m length)
- ZL-C0-CBL20-2 (2.0 m length)



ZL-RTB20 20-pin feed-through connector module

General Specifications	
Field to Logic Side Isolation	1800VAC for 1 sec.
External 24VDC Power Required	75mA
Bus Power Required (24VDC)	25mA
Recommended Fuse (External)	AutomationDirect p/n S500-32-R (0.032 A fuse)
Terminal Block Replacement	AutomationDirect p/n C0-16TB
Weight	3.1 oz (86g)

Input Specifications	
Inputs per Module	4
Input Range	0-20 mA (sink)
Resolution	13-bit, 2.44 uA per count
Input Type	Single ended (one common)
Maximum Continuous Overload	±44 mA
Input Impedance	124Ω, 0.5 W current input
Filter Characteristics	Low pass, -3 dB at 400 Hz
PLC Data Format	13-bit unsigned Integer, range is 0-8191
Sample Duration Time	5 ms
All Channel Update Rate	20 ms (input plus output maximum time)
Open Circuit Detection Time	Zero reading within 20 ms
Conversion Method	Successive approximation
Accuracy vs. Temperature	±75 PPM/°C maximum
Maximum Inaccuracy	0.5% of range (including temperature changes)
Linearity Error (End to End)	±3 count maximum, monotonic with no missing codes
Input Stability and Repeatability	±2 count maximum
Full Scale Calibration Error (Including Offset)	±8 count maximum
Offset Calibration Error	±8 count maximum
Maximum Crosstalk at DC, 50/60 Hz	±2 count maximum

C0-4AD2DA-1 – 4-Channel Analog Current Input and 2-Channel Analog Current Output Module (continued)

Output Specifications	
Outputs per Module	2
Output Range	4–20 mA (source)
Resolution	12-bit, 3.9 uA per count
Output Type	Current sourcing at 20mA max. (One common)
PLC Data Format	12-bit unsigned integer, 0–4095 counts
Output Value in Fault Mode	Less than 4mA
Load Impedance	0–600 Ω at 24VDC; minimum load: 0 Ω 32° to 113°F (0° to 45°C); 125 Ω 113° to 131°F (45° to 55°C) ambient temp.
Maximum Inductive Load	1mH
Allowed Load Type	Grounded
Maximum Inaccuracy	±1% of range
Max. Full Scale Calibration Error (Including Offset)	±0.2% of range maximum
Max. Offset Calibration Error	±0.2% of range maximum
Accuracy vs. Temperature	±50 PPM/°C maximum full scale calibration change (±0.005% of range/°C)
Max. Crosstalk at DC, 50/60 Hz	-72 dB, 1 LSB
Linearity Error (End to End)	±4 LSB maximum, (±0.1% of full scale), monotonic with no missing codes
Output Stability and Repeatability	±2% LSB after 10 minute warmup period typical
Output Ripple	±0.1% of full scale
Output Settling Time	0.2 ms maximum, 5 μ s min. (full scale range)
All Channel Update Rate	20ms
Max. Continuous Overload	Outputs open circuit protected
Type of Output Protection	Electronically limited to 20mA or less
Output Signal at Power Up or Power Down	4mA

C0-4AD2DA-2 – 4-Channel Analog Voltage Input and 2-Channel Analog Voltage Output Module

4-channel analog voltage input (13-bit resolution) and 2-channel analog voltage output (12-bit resolution) module, range: 0-10V. External 24VDC power required, removable terminal block included.

Wiring Diagram

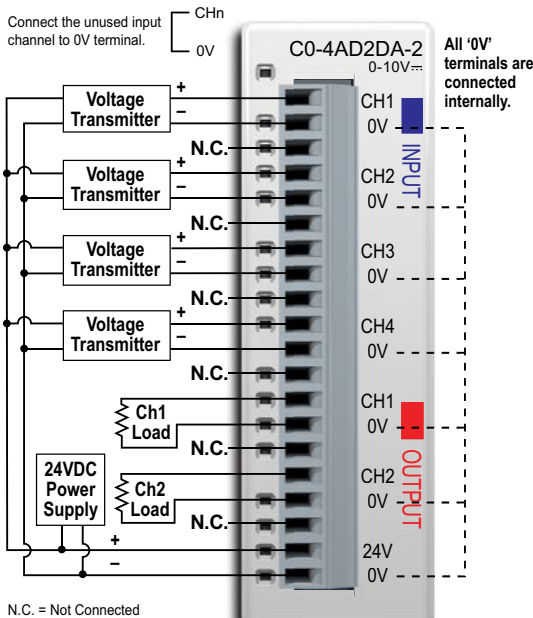

NOTE: When using this module you must also use CLICK programming software and PLC firmware version V1.40 or later.

ZIPLink Pre-Wired PLC Connection Cables and Modules for CLICK PLC

- 20-pin connector cable
- ZL-C0-CBL20 (0.5 m length)
- ZL-C0-CBL20-1 (1.0 m length)
- ZL-C0-CBL20-2 (2.0 m length)



General Specifications	
Field to Logic Side Isolation	1800VAC for 1 sec.
External 24VDC Power Required	65mA
Base Power Required (24VDC)	20mA
Terminal Block Replacement	AutomationDirect p/n C0-16TB
Weight	3.1 oz (86g)

Input Specifications	
Inputs per Module	4
Input Range	0-10 V
Resolution	13-bit, 1.22 mV per count
Input Type	Single ended (one common)
Maximum Continuous Overload	±100VDC
Input Impedance	>150kΩ
Filter Characteristics	Low pass, -3dB at 500Hz
Sample Duration Time	5ms
All Channel Update Rate	20ms
Open Circuit Detection Time	Zero reading within 100ms
Conversion Method	Successive approximation
Accuracy vs. Temperature	±75 PPM/°C maximum
Maximum Inaccuracy	0.5% of range (including temperature changes)
Linearity Error (End to End)	±3 count maximum, monotonic with no missing codes
Input Stability and Repeatability	±2 count maximum
Full Scale Calibration Error (including Offset)	±8 count maximum
Offset Calibration Error	±8 count maximum
Maximum Crosstalk at DC, 50/60 Hz	±2 count maximum



ZL-RTB20 20-pin feed-through connector module

C0-4AD2DA-2 – 4-Channel Analog Voltage Input and 2-Channel Analog Voltage Output Module (continued)

Output Specifications	
Outputs per Module	2
Output Range	0-10 V
Resolution	12-bit, 2.44 mV per count
Output Type	Voltage sourcing at 10mA max. (One common)
Output Value in Program Mode	Determined by PLC
Output Value in Fault Mode	0V
Output Impedance	0.2 Ω typical
Load Impedance	>1000 Ω
Maximum Capacitive Load	0.01 μ F maximum
Allowed Load Type	Grounded
Maximum Inaccuracy	1% of range
Max. Full Scale Calibration Error (Not including Offset)	\pm 0.2% of range maximum voltage
Max. Offset Calibration Error	\pm 0.2% of range maximum
Accuracy vs. Temperature	\pm 75 PPM/ $^{\circ}$ C maximum full scale calibration change (\pm 0.0025% of range/ $^{\circ}$ C)
Max. Crosstalk at DC, 50/60 Hz	-72dB, 1 LSB
Linearity Error (End to End)	\pm 4 LSB maximum, (\pm 0.1% of full scale); monotonic with no missing codes
Output Stability and Repeatability	\pm 2% LSB after 10 minute warmup period typical
Output Ripple	0.5% of full scale
Output Settling Time	0.3 ms maximum, 5 μ s minimum (full scale range)
All Channel Update Rate	20ms
Max. Continuous Overload	Outputs current limited to 40mA typical; continuous overloads on multiple outputs can damage module.
Type of Output Protection	0.1 μ F transient suppressor
Output Signal at Power Up or Power Down	0V

Power Supply Specifications

C0-00AC Power Supply



Limited auxiliary AC power supply allows you to power the CLICK PLC with 100-240 VAC supply power. The 0.5 A DC power supply is capable of controlling the PLC plus a limited configuration based on the power budget of each I/O module. The C0-00AC is a low-cost solution for applications requiring only minimal I/O and power consumption. This power supply will not support a fully-populated CLICK PLC system with all possible I/O module combinations.

C0-00AC Input Specifications

Input Voltage Range	85–264 VAC
Input Frequency	47–63 Hz.
Input Current (typical)	0.3 A @ 100 VAC, 0.2 A @ 200VAC
Inrush Current	30A
Efficiency	80% typical

C0-00AC Output Specifications

Output Voltage Range	23–25 VDC
Output Current	0.5 A
Ripple	200mV p-p max (0–55°C)
Ripple Noise	300mV p-p max (0–55°C)
Over Current Protection	@ 0.65 A (automatic recovery)
Over Voltage Protection	@ 27.6 V (clamped by Zener diode)
Start-up Time	1000ms max at rated input and load
Hold-up Time	10ms minimum at 85VAC, I=max

C0-00AC General Specifications

Ambient Operating Temperature	32–131°F [0–55°C]
Storage Temperature	–4–158°F [–20–70°C]
Humidity	30–95%, non-condensing
Vibration Resistance	JIS C60068-2-6, sine wave vibration
Shock Resistance	JIS C60068-2-27
Voltage Withstand	
Input-Output	1500VAC, 5mA cutoff current
Input-Ground	1500VAC, 5mA cutoff current
Output-Ground	500VAC, 5mA cutoff current
Insulation Resistance	
Input-Output	10MΩ minimum, 500VDC
Input-Ground	10MΩ minimum, 500VDC
Output-Ground	5MΩ minimum, 500VDC
Noise Immunity	FCC Class A, EN55022:1998 Class A
Input/Output Interface	5P terminal block, Fujicon UF2362AX series or equivalent
Agency Approvals	UL508, UL1604, EN61010-1 (IEC 1010-1), CAN/CSA E60079-15:02, JIS C0025
Weight	5.3 oz [150g]

C0-01AC Power Supply

No-limit auxiliary AC power supply allows you to power the CLICK PLC with 100-240 VAC supply power. The 1.3 A DC power supply is capable of supporting a fully-populated CLICK PLC system with all possible I/O module combinations with no concerns of exceeding the power budget.



C0-01AC Input Specifications	
Input Voltage Range	85-264 VAC
Input Frequency	47-63 Hz.
Input Current (typical)	0.9 A @ 100 VAC, 0.6 A @ 200VAC
Inrush Current	30A
Efficiency	80% typical

C0-01AC Output Specifications	
Output Voltage Range	23-25 VDC
Output Current	1.3 A
Ripple	200mV p-p max (0-55°C)
Ripple Noise	300mV p-p max (0-55°C)
Over Current Protection	@ 1.6 A (automatic recovery)
Over Voltage Protection	@ 27.6 V (clamped by Zener diode)
Start-up Time	1000ms max at rated input and load
Hold-up Time	10ms minimum at 85VAC, I=max

C0-01AC General Specifications	
Ambient Operating Temperature	32-131°F [0-55°C]
Storage Temperature	-4-158°F [-20-70°C]
Humidity	30-95%, non-condensing
Vibration Resistance	JIS C60068-2-6, sine wave vibration
Shock Resistance	JIS C60068-2-27
Voltage Withstand	
Input-Output	1500VAC, 5mA cutoff current
Input-Ground	1500VAC, 5mA cutoff current
Output-Ground	500VAC, 5mA cutoff current
Insulation Resistance	
Input-Output	10MΩ minimum, 500VDC
Input-Ground	10MΩ minimum, 500VDC
Output-Ground	5MΩ minimum, 500VDC
Noise Immunity	FCC Class A, EN55022:1998 Class A
Input/Output Interface	5P terminal block, Fujicon UF2362AX series or equivalent
Agency Approvals	UL508, UL1604, EN61010-1 (IEC 1010-1), CAN/CSA E60079-15:02, JIS C0025
Weight	6.0 oz [170g]

PSP24-DC12-1 DC-DC Converter

With this DC-DC converter you can operate the CLICK PLC with 12VDC input power.



PSP24-DC12-1 DC-DC Converter Specifications	
Input Voltage Range	9.5–18 VDC
Input Power (no load)	1.0 W max.
Startup Voltage	8.4 VDC
Undervoltage Shutdown	7.6 VDC
Output Voltage Range	24–28 VDC (adjustable)
Output Current	1.0 A
Short Circuit Protection	Current limited at 110% typical
Weight	7.5 oz (213g)

Please see this part at www.automationdirect.com/pn/PSP24-DC12-1 on our web store for full specifications.

Programming Software

The CLICK PLC Programming Software, which can be downloaded free from the Automationdirect.com web site (Downloads/Software), is designed to provide simple and fast application development of ladder logic programming.

These are some of the features that help make this happen:

- The Navigation window allows organization of the ladder logic programs used in your project and access to the functions, settings and configurations used to work with your project.
- The Instruction List window displays all available CLICK PLC instructions, allows you to drag and drop the instruction into your ladder logic program, and then enter any values and/or parameters required for the particular instruction.
- You can add Subroutine and Interrupt programs separately from the main ladder logic program. This allows you to manage your ladder logic programs in a simple, structured environment and, at the same time, aid in trouble-shooting your program.
- The Data View Monitor window configurations are saved with your project. This allows quick access to the same set of memory addresses that may have been set up for viewing during testing of your program.
- The graphical represented System Configuration dialog box allows checking the PLC system configuration. A Power Budget calculation feature is included. Refer to the Power Budgeting section later in this chapter for additional details.
- The Address Picker window allows quick selection of any memory address to be placed in the ladder logic program. Refer to the programming software online help for additional details.
- The PLC module Firmware can be updated from the programming software within 7 minutes.

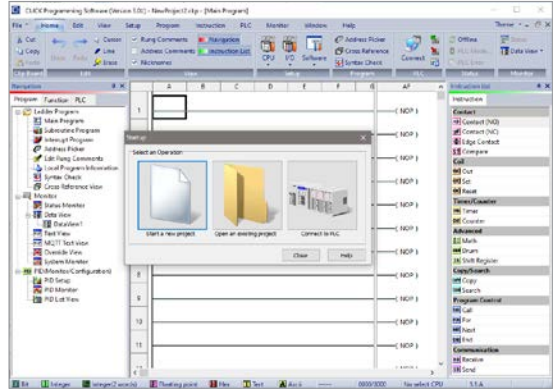

PC Requirements

Check our online webstore for current operating system requirements:







<http://www.automationdirect.com>

Data Types, Memory, and Numbering System

The following section explains how the CLICK PLC handles the available data types, memory addressing, and I/O numbering.

Data Types

The CLICK PLC supports the following data types. On the CLICK PLC programming software, each data type is indicated with a small icon.









Data Type	S/W Icon	Data Ranges
Bit		0, 1
Integer (Single Word)		-32,768 to 32,767
Integer2 (Double Word)		-2,147,483,648 to 2,147,483,647
Floating Point		-3.4028235E+38 to 3.4028235E+38
HEX (Hexadecimal)		0000h to FFFFh (The HEX data type requires the 'h' after the value.)
Text (Single Character)		Single ASCII character (ASCII code: 00h to FFh.)
ASCII Code		ASCII code \$00 to \$FF (The ASCII Code data type requires the '\$' before the value.)



NOTE: The CLICK PLC does not support Octal or BCD numbering systems (data types).

Memory Types

The following is the list of the memory types that the CLICK PLC system supports. See the memory map later in this chapter.

Memory Type	Symbol	Data Type	S/W Icon	Definition
Input Point	X	Bit		The Discrete Input points are represented by the "X" symbol.
Output Point	Y			The Discrete Output points are represented by the "Y" symbol.
Control Relay	C			The Control Relay bits are represented by the "C" symbol. These internal bits are typically used for ladder program control. They do not represent any real world inputs or outputs.
Timer	T			The Timers are represented by the "T" symbol. The Timer status bit is used to indicate when the Current Value of the timer equals its Preset Value.
Counter	CT			The Counters are represented by the "CT" symbol. The Counter status bit is used to indicate when the Current Value of the counter equals its Preset Value.
System Control Relay	SC			The internal System Control Relays, represented by the "SC" symbol, are pre-defined bits which represent the status of specific system functions.
Data Register	DS	Integer		Single word integer data registers are represented by the "DS" symbol.
	DD	Integer2		Double word integer data registers are represented by the "DD" symbol.
	DH	HEX		Single word Hex data registers are represented by the "DH" symbol.
	DF	Floating Point		Data Floating Point registers are IEEE format Real number values represented by the "DF" symbol as 32-bit words.
Input Register	XD	HEX		The Input Registers, represented by the "XD" symbol, contain groups of Discrete Input points in a 16-bit word format. XD0 is a Hexadecimal representation of X1-X16, XD1 of X101-X116, etc.
Output Register	YD			The Output Registers, represented by the "YD" symbol, contain groups of Discrete Output points in a 16-bit word format. YD0 is a Hexadecimal representation of Y1-Y16, YD1 of Y101-Y116, etc.
Timer Register	TD	Integer		The Timer Registers, represented by the "TD" symbol, contain the corresponding Timer's accumulative value in a 16-bit data register.
Counter Register	CTD	Integer2		The Counter Registers, represented by the "CTD" symbol, contain the corresponding Counter's accumulative value in a 32-bit data register.
System Data Register	SD	Integer		The internal System Data Registers, represented by the "SD" symbol, are pre-defined words which represent the status of specific system functions.
Text	TXT	Text		The Text data registers, represented by the "TXT" symbol, are used to store and manipulate ASCII text data.

Memory Types (cont'd)

Pointer Addressing

The CLICK PLUS PLC allows the use of Pointer Addressing for flexibility in programming. The Copy instruction supports Pointer Addressing in the single copy mode. The Pointer is always assigned as a DS memory type and is designated as a Pointer by placing the DS memory type in square brackets, such as [DS1]. Pointer Addressing uses the Pointer's data value to point to a memory location within the range of one of the eligible memory types. Pointer Addressing can be used with the C, DS, DD, DF, DH, XD, YD, TD, CTD and TXT data register memory types.

Pointer Addressing is also sometimes referred to as Indirect Addressing. One of the many uses for Pointer Addressing would be to perform lookup in tables. An application example might be determining the number of gallons in a horizontal tank when the liquid level is known. The gallons could be determined by a rather complex math formula, but a simpler approach would be to pre-calculate the number of gallons at several uniform levels, and place these values into a table of data registers that can be accessed using Pointer Addressing.

Pointer Addressing Example

DS1 = 100; data register DS1 is assigned the value of 100.

Then the use of DD[DS1] would be the same as showing DD100.

As the value in DS1 is changed, the result would then point to a different DD data register.

In the example, data register DS1 is called a Pointer. Only a DS memory type can be used as a pointer. As mentioned before, the use of the [square brackets] around DS1 in the data register reference DD[DS1] is how the Pointer Addressing is designated.

I/O Numbering System

The CLICK PLC uses decimal numbers for the input (X) and output (Y) addressing.

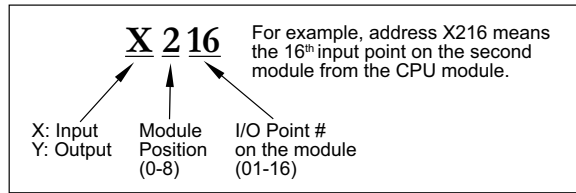

Module Location

Please refer to the following diagram to understand the module position and I/O numbering.

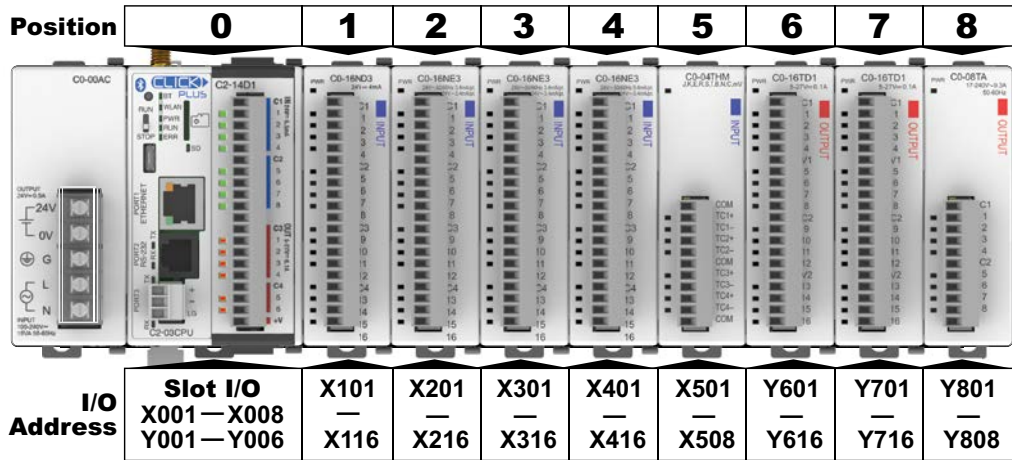

The I/O Addressing can be checked by using the System Configuration window from within the CLICK programming software. From the Setup pulldown menu, select System Configuration; otherwise, from the Navigation window select the Function tab, and under PLC configuration, double click on System Configuration.

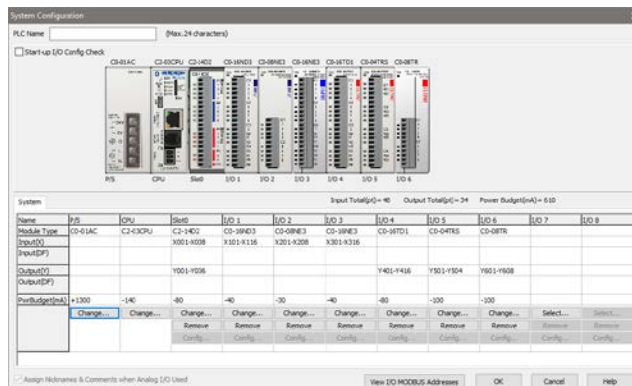

PLC Operation

Introduction

Achieving proper control of your equipment or process requires a thorough understanding of how the CLICK PLUS PLC controls all aspects of system operation. There are three main areas to understand before you create your application program:

- PLC Operating System – the PLC manages all aspects of system control. A quick overview of all the steps are provided in the next section.
- PLC Operating Modes – The two primary modes of operation are Stop mode and Run mode.
- PLC Memory Map – CLICK PLCs offer a wide variety of resources, such as timers, counters, inputs, etc. The Memory Map section shows the organization and availability of these data types.

PLC Operating System

At powerup, the CLICK PLUS PLC initializes the internal electronic hardware. Memory initialization starts with examining the retentive memory settings. In general, the contents of retentive memory are preserved, and non-retentive memory is initialized to zero (unless otherwise specified).

After the one-time powerup tasks, the PLC begins the cyclical scan activity. The flowchart to the right shows how the tasks differ, based on the PLC mode and the existence of any errors. The “scan time” is defined as the average time around the task loop. Note that the PLC is always reading the inputs, even during Stop mode. This allows programming tools to monitor input status at any time.

The outputs are only updated in Run mode. In Stop mode, they are in the off state.

Error detection has two levels. Non-fatal errors are reported, but the PLC remains in its current mode. If a fatal error occurs, the PLC is forced into Stop mode and the outputs turn off.

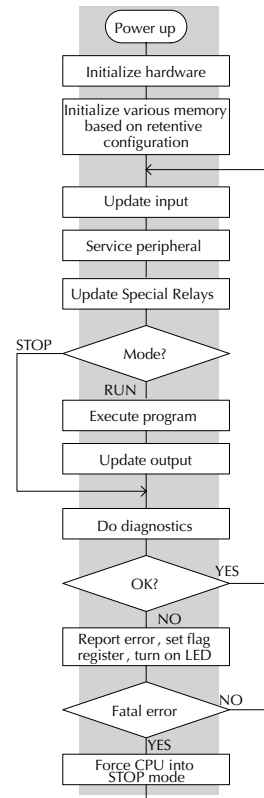

PLC Operating Modes

Stop Mode

In Stop mode, the CLICK PLUS PLC does NOT execute the ladder logic program or update the output points. The primary use for Stop Mode is to enter or change a ladder logic program. You also use Stop mode to set up the PLC parameters, such as retentive memory areas, etc.

You can use CLICK Programming Software, or the CLICK PLUS PLC mode switch to place the PLC in Stop mode; however, the CLICK PLUS PLC mode switch will override the software mode condition. If the PLC mode switch is in the Stop position, the software is blocked from changing the PLC mode. When the PLC mode switch is in the Run position, the software may toggle the mode switch from Run to Stop at will.



Run Mode

In Run mode, the PLC executes the application program and updates the I/O system. You can perform many operations during Run mode. Some of these include:

- Monitor and change I/O point status
- Change timer/counter preset values
- Change variable memory locations

The Run Mode can be divided into several key areas. For the vast majority of applications, some of these execution segments are more important than others. For example, you need to understand how the PLC updates the I/O points, handles forcing operations, and solves the application program. The remaining segments are not that important for most applications.

You can use CLICK Programming Software, or the CLICK PLUS PLC mode switch to place the PLC in Run mode.

Normal Run Mode Scan

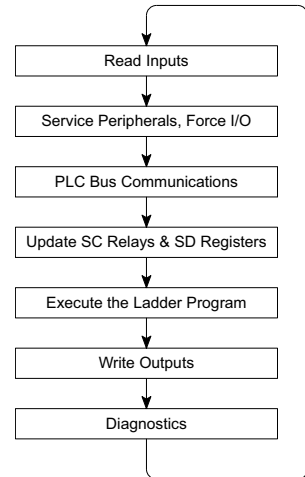

NOTE: The CLICK PLUS PLC will not go into RUN mode if it is in Low Power Mode as a result of powering only through the USB port.



WARNING: Only authorized personnel fully familiar with all aspects of the application should make changes to the ladder logic program. Make sure you thoroughly consider the impact of any changes to minimize the risk of personal injury or damage to equipment.

Read Inputs

The CLICK PLUS PLC reads the status of all inputs, then stores it in the image register. Input image register locations are designated with an X followed by a memory location. Image register data is used by the PLC when it solves the application program.

Of course, an input may change after the PLC has just read the inputs. Generally, the PLC scan time is measured in milliseconds. If you have an application that cannot wait until the next I/O update, you can use Immediate Instructions. These do not use the status of the input image register to solve the application program. The Immediate instructions immediately read the input status directly from the I/O modules. However, this lengthens the program scan since the PLC has to read the I/O point status again.

Service Peripherals and Force I/O

After the CLICK PLUS PLC reads the inputs from the input modules, it reads any attached peripheral devices. This is primarily a communications service for any attached devices. For example, it would read a programming device to see if any input, output, or other memory type status needs to be modified. There are two basic types of forcing available with the CLICK PLC:

- Forcing from a peripheral – not a permanent force, good only for one scan
- Bit Override – holds the I/O point (or other bit) in the current state. Valid bits are X, Y, C, T and CT. (These memory types are discussed in more detail earlier in this chapter).

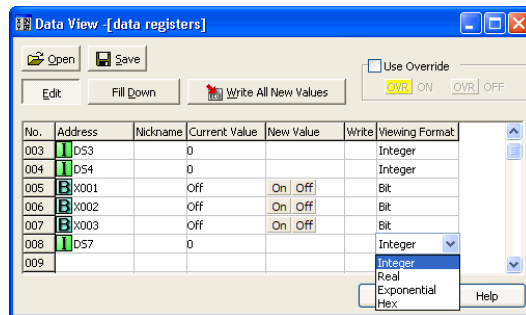

Forcing and Bit Override are done through the Data View Monitor.

Regular Forcing: This type of forcing can temporarily change the status of a discrete bit. For example, you may want to force an input on, even though it is really off. This allows you to change the point status that was stored in the image register. This value will be valid until the image register location is written to during the next scan. This is primarily useful during testing situations when you need to force a bit on to trigger another event.

Bit override: This is a more forceful type of bit manipulation. When bit override is enabled, you can actually override the current status of a bit in the image register. This change will remain intact until you remove the override.



WARNING: Only authorized personnel fully familiar with all aspects of the application should make changes to the program. Make sure you thoroughly consider the impact of any changes to minimize the risk of personal injury or damage to equipment.

Update System Control (SC) Relays and System Data (SD) Registers

The CLICK PLUS PLC units have system memory locations that hold this information. This portion of the execution cycle ensures these locations get updated on every scan. Also, there are several different system control relays, such as diagnostic relays, etc., that are also updated during this segment.

Solve Application Program

The CLICK PLUS PLC evaluates each instruction in the application program during this segment of the scan cycle. The instructions define the relationship between the input conditions and the desired output response. The CLICK PLUS PLC uses the output image register area to store the status of the desired action for the outputs. Output image register locations are designated with a Y followed by a memory location. The actual outputs are updated during the write outputs segment of the scan cycle.

The internal control relays (C) and the data registers (DS, DD, DF and DH) are also updated in this segment.

You may recall that you can force various types of points in the system, discussed earlier in this chapter. If any I/O points or memory data have been forced, the output image register also contains this information.

Write Outputs

Once the application program has solved the instruction logic and constructed the output image register, the CLICK PLC writes the contents of the output image register to the corresponding output points. Remember, the PLC also ensured that any forcing operation changes were stored in the output image register, so the forced points get updated with the status specified earlier.

Diagnostics

During this part of the scan, the PLC performs all system diagnostics and other tasks such as calculating the scan time and resetting the watchdog timer. There are many different error conditions that are automatically detected and reported by the CLICK PLUS PLC. Chapter 6: *Troubleshooting* contains a listing of the various error codes with a description of the possible causes.

Probably one of the more important things that occurs during this segment is the scan time calculation and watchdog timer control. The CLICK PLUS PLC has a watchdog timer that stores the maximum time allowed for the PLC to complete the solve application part of the scan cycle. If this time is exceeded, the PLC will enter the Stop mode and turn off all outputs. An error is automatically reported. The default value of the watchdog timer is 200ms and can be adjusted between 5–10,000 ms. Refer to the online help available from the CLICK Programming Software, C0-PGMSW, for additional information in regards to the Watchdog Timer.

Accessories

C2-USER-M – CLICK PLUS PLC Hardware Users Manual



Manual covers all CLICK PLUS PLC & I/O Module installation & wiring, specifications, error codes & trouble shooting guide. The CLICK PLUS PLC Hardware User Manual can be downloaded free at the AutomationDirect Web site, www.automationdirect.com

C0-PGMSW – CLICK PLC Programming Software USB



CLICK PLC programming software Ladder Logic Editor for Windows PCs, includes the manual as a pdf file. Free download available from AutomationDirect online Web store: www.automationdirect.com. Alternatively the programming software USB may be purchased and shipped from the AutomationDirect online Web store: www.automationdirect.com

USB-CBL-AMICB6 – USB A to USB micro B Programming Cable Assembly



Programming cable, USB A to micro-B USB, 6ft cable length. For use with Productivity1000 and Productivity2000 CPUs, CLICK PLUS CPUs and most USB devices. The USB port supplies 5VDC to the CLICK PLUS CPU for programming.

EA-MG-PGM-CBL – PC to Panel Programming Cable Assembly for C-more Micro-Graphic Panels and CLICK/CLICK PLUS PLCs



6-ft cable assembly connects a personal computer to any C-more Micro-Graphic panel, CLICK PLC, or select CLICK PLUS PLC for setup and programming. Assembly includes standard USB A-type connector to B-type connector cable, custom converter, and a RS232C cable with RJ12 modular connector on each end

D2-DSCBL – PC Programming Cable for CLICK and DirectLOGIC PLCs



12ft (3.66 m) RS232 shielded PC programming cable for CLICK, DL05, DL06, DL105, DL205, D3-350, and D4-450 CPUs. 9-pin D-shell female connector to an RJ12 6P6C connector.

Cat5e – PC Programming Ethernet Cable for CLICK PLCs



3ft–50ft Cat5e STP Ethernet Patch Cable for PC programming of CLICK PLCs; RJ45 connector. Straight or Cross-over cable can be used.

Accessories (cont'd)

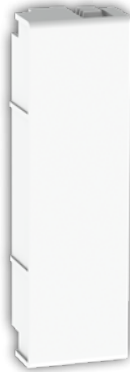

C2-FILL
CPU Option Slot Cover

Snap-on cover for CPU Option Slot in applications without an Option Slot module present.



MSD-SLC16G

16GB microSD card, industrial grade, 3D NAND Flash (with SLC Mode), 85°C [185°F] max operating temp.



SE-ANT210

Whip/straight 2.4 GHz antenna, IP65, connector mount.



SE-ANT250

Dome 2.4 GHz antenna, IP67, panel mount, 9.8ft/3m cable length.

2.4 GHz WiFi Antenna Specifications		
	SE-ANT210	SE-ANT250
Antenna Connector	RP-SMA (M)	
Application	WLAN (802.11 b/g/n), Bluetooth (IEEE 802.15.1)	
Impedance	50Ω	
Antenna Type	whip, straight	dome
Cable Length	N/A	3m [9.8 ft]
Frequency Range	2.4-2.5 GHz	2.4-2.5 GHz
Gain	1.8 dBi	1.5 dBi
Height	1.2 in	1.89 in
IP Rating	IP65	IP67
Maximum Power	1W	5W
Mounting Screw Torque	NA	2.94 N·m

Accessories (cont'd)

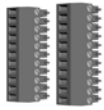

C0-8TB – Spare 8 Point I/O Terminal Block

Replacement terminal block for the 8 point I/O modules. Sold in packs of 2.

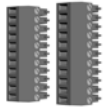

C0-8TB-1 – Spare 8 Point I/O Terminal Block

Replacement terminal block for the 8 point relay I/O modules. Sold in packs of 2.

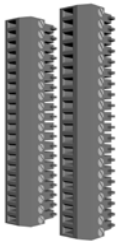

C0-16TB – Spare 16 Point I/O Terminal Block

Replacement terminal block for the 16 point I/O modules & Option Slot I/O. Sold in packs of 2.



C0-3TB - Spare 3-Pole Terminal Block

Replacement 3-pole terminal block for the 3-wire, RS485 communications port on the C2-03CPU and C2-03CPU-02 PLCs. Sold in packs of 2.



C0-4TB – Spare 24VDC Power Terminal Block

Replacement terminal block for the 24VDC supply power to the PLC. Sold in packs of 2.



C2-6TB - Spare 6-Pole Terminal Block

Replacement 6-pole terminal block for the C2-DCM. Sold in packs of 2.



D0-MC-BAT – Battery

Replacement battery for CLICK PLUS PLC units.

ZIPLink Wiring Systems

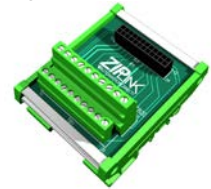

C-more and C-more Micro-Graphic Operator Interfaces



DN-WS – Wire Stripper



TW-SD-MSL-2 – Insulated Slotted Screwdriver 0.4 x 2.5 x 80 mm



DN-EB35MN – DINnectors End Bracket

