

BX 36/36E WIRING

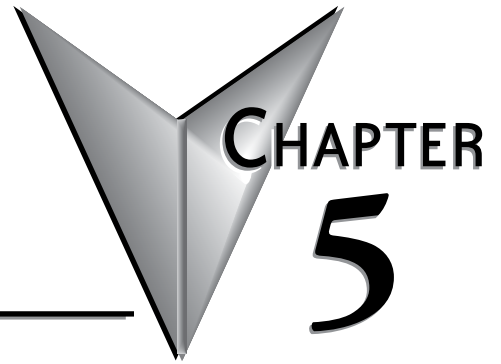

In This Chapter...

| | |
|--|-------|
| BX 36/36E Micro PLC Units (MPUs) Overview | 5-2 |
| BX 36 MPUs General Specifications | 5-3 |
| BX 36E MPUs General Specifications | 5-4 |
| BX 36/36E MPU Wiring Termination Selection | 5-5 |
| BX 36 Micro PLC Units (MPUs) | 5-9 |
| BX-DM1-36ED1 Wiring | 5-9 |
| BX-DM1-36ED1-D Wiring | 5-15 |
| BX-DM1-36ED2 Wiring | 5-21 |
| BX-DM1-36ED2-D Wiring | 5-27 |
| BX-DM1-36ER Wiring | 5-33 |
| BX-DM1-36ER-D Wiring | 5-39 |
| BX-DM1-36AR Wiring | 5-45 |
| BX 36E Micro PLC Units (MPUs) | 5-50 |
| BX-DM1E-36ED13 Wiring | 5-50 |
| BX-DM1E-36ED13-D Wiring | 5-59 |
| BX-DM1E-36ED23 Wiring | 5-68 |
| BX-DM1E-36ED23-D Wiring | 5-77 |
| BX-DM1E-36ER3 Wiring | 5-86 |
| BX-DM1E-36ER3-D Wiring | 5-95 |
| BX-DM1E-36AR3 Wiring | 5-104 |

BX 36/36E Micro PLC Units (MPUs) Overview

The BX 36/36E Micro PLC Unit (MPU) includes fourteen different versions. All have the same appearance and basic features. All units have 20 discrete input points and 16 discrete output points built-in. Units with DC inputs have 10 selectable high-speed inputs and units with DC outputs have 8 selectable high-speed outputs. All MPUs can expand their capacity with the BRX Expansion Modules to allow for more flexibility while keeping control cost down. BX 36E units have an Ethernet port as well as an additional 4 analog inputs and 2 analog outputs built-in that are current/voltage selectable within the software.

The units ship without wiring terminals. This allows you to select the termination type that best fits your application. There are several wiring options available, including screw terminal connectors, spring clamp terminal connectors and pre-wired *ZIPLink* cable solutions.

BX 36/36E MPUs are divided into two distinct groups, BX 36 and BX 36E. The BX 36 MPUs have no built-in analog I/O or Ethernet port. The BX 36E MPUs have all the features of the BX 36, plus built-in analog I/O and an Ethernet port.

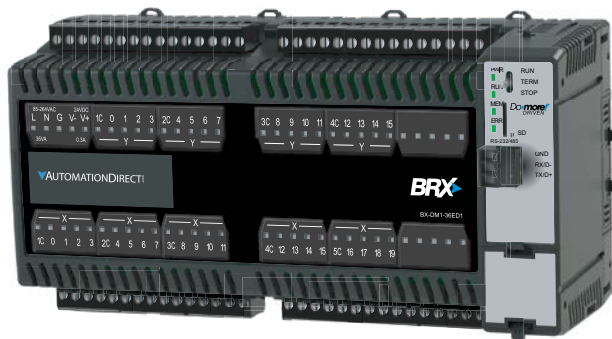

BX 36 Micro PLC Unit (MPU)
(No Built-in Analog or Ethernet Port)

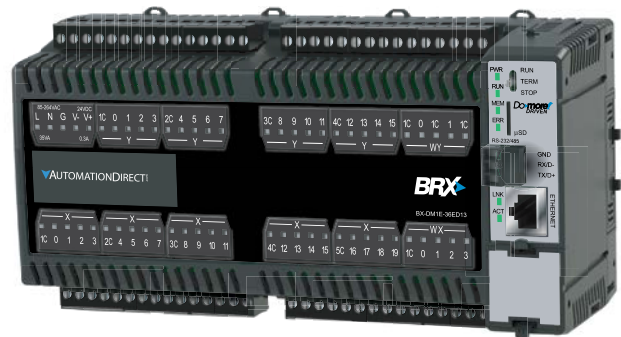

BX 36E Micro PLC Unit (MPU)
(Built-in Analog and Ethernet Port)

BX 36 MPUs General Specifications

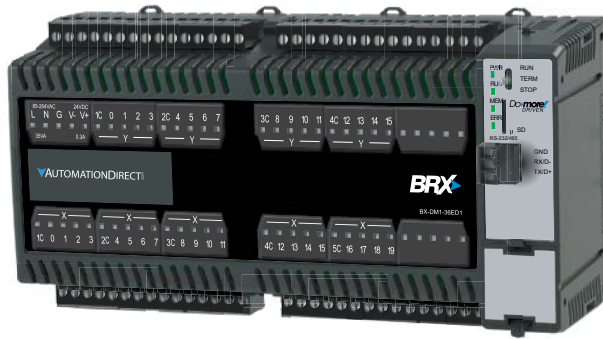

BX 36 Micro PLC Unit (MPU)
(No Built-in Analog or Ethernet port)

- 36 discrete I/O points: 20 input, 16 output
- No built-in analog I/O points
- Models with DC inputs:
 - have 10 high-speed inputs rated up to 250kHz
 - accept 12–24 nominal voltage, AC or DC
 - can be wired as sinking or sourcing
- Models with AC inputs can accept 120–240 nominal voltages
- Output types available are DC sinking, DC sourcing, and relay
- Models with DC outputs have 8 high-speed outputs rated up to 250kHz
- Support for 4 additional Expansion Modules

The following table shows the available BX 36 MPUs.

| BX 36 MPUs | | | | |
|----------------|----------------|--|---|-------------------|
| Part Number | External Power | Discrete Input | Discrete Output | Expansion Modules |
| BX-DM1-36ED1 | 120–240 VAC | 10 High-speed 10 Standard DC Sinking or Sourcing | 8 High-speed 8 Standard DC Sinking | 4 |
| BX-DM1-36ED1-D | 12–24 VDC | | 8 High-speed 8 Standard DC Sourcing | |
| BX-DM1-36ED2 | 120–240 VAC | | | |
| BX-DM1-36ED2-D | 12–24 VDC | | | |
| BX-DM1-36ER | 120–240 VAC | 20 AC | 16 Form A Relay | |
| BX-DM1-36ER-D | 12–24 VDC | | | |
| BX-DM1-36AR | 120–240 VAC | | | |

BX 36E MPUs General Specifications

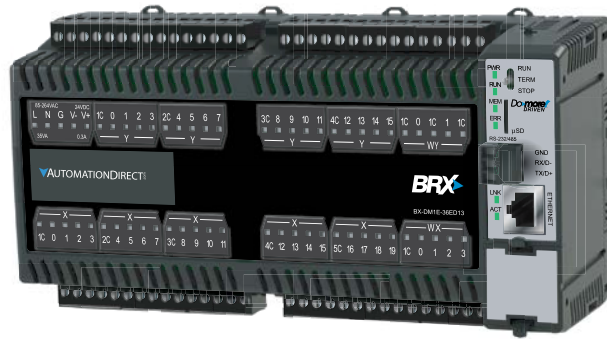

BX 36E Micro PLC Unit (MPU)
(Built-in Analog and Ethernet Port)

- 36 Discrete I/O points: 20 inputs, 16 outputs
- All units have 4 analog input and 2 analog output (current/voltage software selectable)
- All units have built-in Ethernet port, 10/100 Mbps
- Models with DC inputs:
 - have 10 high-speed inputs rated up to 250kHz
 - accept 12–24 nominal voltages, AC or DC
 - can be wired as sinking or sourcing
- Models with AC inputs can accept 120–240 nominal voltages
- Output types available are DC sinking, DC sourcing, and relay
- Models with DC outputs have 8 high-speed outputs rated up to 250kHz
- Support for 8 additional Expansion Modules

The following table shows the available BX 36E MPUs.

| BX 36E MPUs | | | | | | |
|------------------|----------------|--|---|-------------------------------|-------------------------------|-------------------|
| Part Number | External Power | Discrete Inputs | Discrete Output | Analog * | | Expansion Modules |
| | | | | Input | Output | |
| BX-DM1E-36ED13 | 120–240 VAC | 10 High-speed 10 Standard DC Sinking or Sourcing | 8 High-Speed 8 Standard DC Sinking | 4 Current or Voltage | 2 Current or Voltage | 8 |
| BX-DM1E-36ED13-D | 12–24 VDC | | | | | |
| BX-DM1E-36ED23 | 120–240 VAC | | 8 High-Speed 8 Standard DC Sourcing | | | |
| BX-DM1E-36ED23-D | 12–24 VDC | | | | | |
| BX-DM1E-36ER3 | 120–240 VAC | | 16 Form A Relay | | | |
| BX-DM1E-36ER3-D | 12–24 VDC | | | | | |
| BX-DM1E-36AR3 | 120–240 VAC | 20 Standard AC | | | | |

* Analog can be current or voltage software selectable per channel.

BX 36/36E MPU Wiring Termination Selection

The BX 36/36E MPUs ship without terminal blocks. This allows you to select the termination type that best suits your application. There are several removable terminal block options available, including screw terminals, spring clamp terminals, as well as pre-wired *ZIPLink* module and cable solutions.

Terminal Block Connectors

The terminal block connectors are provided in kits and can be easily ordered as a single part number. Each kit contains the required number of terminal blocks: (12) 5-pin 5mm terminal blocks.

The BX 36/36E MPUs terminals are configured into groups consisting of 4 inputs and 4 outputs each with an isolated common, e.g., inputs X0–X3 are grouped with a common terminal. The groups are isolated such that a single 5-pin connector can be removed without affecting another group of I/O or the external power source.

The terminal block connector kit part numbers and connector specifications are listed in the table below.

| Removable Terminal Block Connector Specifications | | |
|---|-------------------------|---|
| Kit Part Number | BX-RTB36 | BX-RTB36-1 |
| Connector Type | Screw Type-90 degree | Spring Clamp Type-180 degree |
| Wire Exit | 180 degree | 180 degree |
| Pitch | 5.0 mm | 5.0 mm |
| Screw Size | M2.5 | N/A |
| Recommended Screw Torque | < 3.98 lb·in (0.45 N·m) | N/A |
| Screwdriver Blade Width | 3.5 mm | 3.5 mm |
| Wire Gauge (Single Wire) | 28–12 AWG | 28–14 AWG |
| Wire Gauge (Dual Wire) | 28–16 AWG | 28–16 AWG (Dual wire ferrule required) |
| Wire Strip Length | 0.3 in (7.5 mm) | 0.37 in (9.5 mm) |
| Equiv. Dinkle P/N | 5ESDV-05P-BK | 5ESDSR-05P-BK |

BX-RTB36 Screw Terminal Block Kit

This terminal block kit has 12, 90 degree screw terminal blocks with 180 degree wire pass through.



5-Pin

BX-RTB36-1 Spring Terminal Block Kit

This terminal block kit has 12, Spring Clamp wire terminal blocks with 180 degree wire pass through.



5-Pin

Replacement terminal blocks can be ordered online at: www.AutomationDirect.com. Single replacement terminal blocks are listed in table below.

| Replacement Terminal Blocks | | |
|-----------------------------|----------|------------|
| | BX-RTB36 | BX-RTB36-1 |
| 5-pin | BX-RTB05 | BX-RTB05-1 |

ZIPLink Prewired Cable Solutions

ZIPLinks eliminate the normally tedious process of wiring between devices by utilizing prewired cables and DIN rail mount connector modules. ZIPLinks are as simple as plugging in a cable connector at either end or terminating wires at only one end. Pre-wired cables keep installation clean and efficient, using less space at a fraction of the cost of standard terminal blocks. ZIPLink pre-wired cables connect directly from the MPU to a ZIPLink remote terminal block module or with the pigtail cable option, that allows for a convenient solution to wire the BRX platform to third-party devices. For the BX 36/36E MPUs, four (4) cables and four (4) ZIPLink feedthrough modules are needed to connect all the wiring termination points.

There are two (2) feedthrough module options available, the ZL-RTB20 and the ZL-RTB20-1. The ZL-RTB20 is a standard feedthrough remote terminal module while the ZL-RTB20-1 is a feedthrough remote terminal block having a more compact footprint, requiring less space in the control cabinet.

The table below lists the ZIPLink system options for the BX 36/36E MPUs.

| BX 36/36E ZIPLink Selector | | | | | |
|----------------------------|----------------|---|----------------|---|----------------|
| Part No. | Component Type | Module Part No. | Max Qty Needed | Cable Part No.* | Max Qty Needed |
| BX-DM1-36ED1 | Feedthrough | ZL-RTB20 (Standard) -OR- ZL-RTB20-1 (Compact) | 4 | ZL-BX-CBL15 ZL-BX-CBL15-1 ZL-BX-CBL15-2 | 4 |
| BX-DM1-36ED1-D | | | | | |
| BX-DM1-36ED2 | | | | | |
| BX-DM1-36ED2-D | | | | | |
| BX-DM1-36ER | | | | | |
| BX-DM1-36ER-D | | | | | |
| BX-DM1-36AR | | | | | |
| BX-DM1E-36ED13 | | | | | |
| BX-DM1E-36ED13-D | | | | | |
| BX-DM1E-36ED23 | | | | | |
| BX-DM1E-36ED23-D | | | | | |
| BX-DM1E-36ER3 | | | | | |
| BX-DM1E-36ER3-D | | | | | |
| BX-DM1E-36AR3 | | | | | |

* Select the cable length: Blank = 0.5 m, -1 = 1.0 m, -2 = 2.0 m.
Available pigtail cables: ZL-BX-CBL15-1P = 1.0 m, ZL-BX-CBL15-2P = 2.0 m.

ZIPLink Prewired Cables

Custom molded **ZIPLink** prewired cables allow for fast and easy connection of field wiring and remote I/O to the BRX platform. The prewired cables are available in 0.5 meter, 1 meter and 2 meter lengths. Pigtail cables are used to connect the BRX platform directly to third-party devices, lowering your wiring cost and time. The pigtail cables are available in 1 meter and 2 meter lengths.



ZIPLink Remote Feedthrough Modules

Feedthrough modules provide low-cost and compact field wiring screw termination solutions for quickly connecting with the BRX platform. There are two (2) modules available for use with the BRX platform. The ZL-RTB20 and the ZL-RTB20-1. The ZL-RTB20 is a standard 2-row, 20-pin, DIN rail mountable feedthrough module. The ZL-RTB20-1 is a compact 3-row, 24-pin, DIN rail mountable feedthrough module with a smaller footprint design.

The **ZIPLink** remote feedthrough module specifications are listed in the table below.

| ZIPLink Module Specifications | | |
|--------------------------------------|---|---|
| Part Number | ZL-RTB20 (Maximum of 4 Needed) | ZL-RTB20-1 (Maximum of 4 Needed) |
| Number of positions | 20 screw terminals, 2 rows | 24 screw terminals, 3 rows |
| Screwdriver Width | 1/8 in (3.8 mm) maximum | |
| Screw Torque | 4.4 lb·in (0.5 N·m) | |



ZIPLink System Examples

BX 36 MPU with *ZIPLink* pre-wired cables and ZL-RTB20 feedthrough modules.



BX 36 MPU with *ZIPLink* pigtail cables installed.

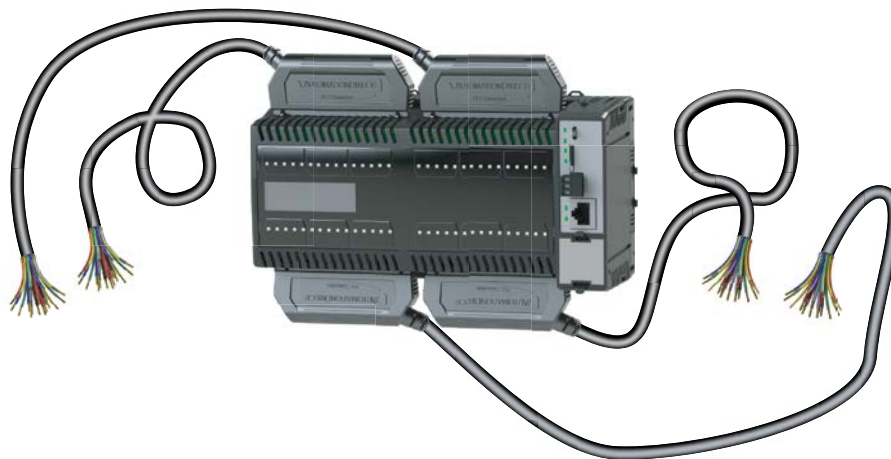

BX 36 Micro PLC Units (MPUs)

BX-DM1-36ED1 Wiring

This MPU is made up of 36 discrete I/O points. The connections are grouped as follows:

- 20 discrete inputs - sinking/sourcing; rated for 12–24 VAC/VDC. They are located along the bottom of the unit; configured in five (5) groups of 5 terminals, each comprised of 5 inputs and an isolated common.
- 16 discrete outputs - sinking; rated at 12–24 VDC. They are located along the top of the unit starting to the right of the 24VDC auxiliary output terminals. The outputs are configured in four (4) groups of 5 terminals, each comprised of 4 outputs and an isolated common.

This MPU requires an external 120–240 VAC power supply. The AC power supply connection and the 24VDC auxiliary output supply terminals are located on the top left side of the unit.



WARNING: No analog I/O is included on this unit. The 5 terminals to the right of the input and output rails are not used. These terminals are not internally connected. DO NOT CONNECT ANYTHING TO THESE TERMINALS!

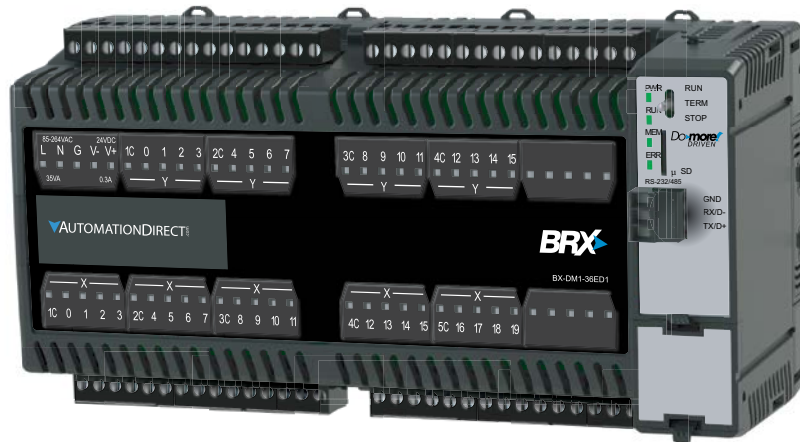

BX-DM1-36ED1



NOTE: Four (4) Expansion Modules can be connected to extend I/O capacity.

BX-DM1-36ED1 Wiring, Continued

Power Supply Specifications

| Power Supply Specifications | |
|-------------------------------------|--|
| Nominal Voltage Range | 120–240 VAC |
| Input Voltage Range (Tolerance) | 85–264 VAC |
| Rated Operating Frequency | 47–63 Hz |
| Maximum Input Power | 40VA |
| Cold Start Inrush Current | 1.5 A, 2ms |
| Maximum Inrush Current (Hot Start) | 1.5 A, 2ms |
| Internal Input Fuse Protection | Micro fuse 250V, 2A Non-replaceable |
| Acceptable External Power Drop Time | 10ms |
| Under Input Voltage Lock-out | 80VAC |
| Input Transient Protection | Input choke and line filter |
| Heat Dissipation | 21.7 W Max |
| Isolated User 24VDC Output | 24VDC @ 0.3 A max, <1V P-P Ripple, Integrated self-resetting short circuit protection |
| Voltage Withstand (dielectric) | 1500VAC Power Inputs to Ground applied for 1 minute 1500VAC Ground to 24VDC Output applied for 1 minute |
| Insulation Resistance | >10MΩ @ 500VDC |
| Software Version Required | Do-more! Designer version 2.0 or later |

Power Supply Connections

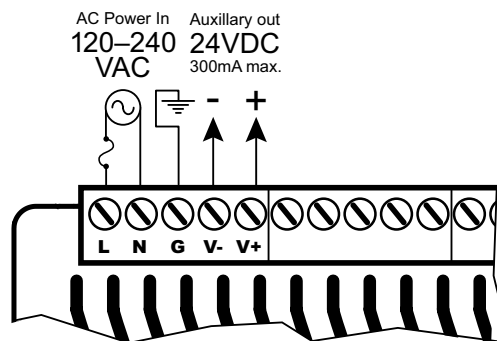

WARNING: Do not exceed the 24VDC auxiliary power supply load limit of 300mA.



WARNING: The BRX System **MUST** have a proper earth ground. Do not operate the BRX MPU without proper earth grounding.

BX-DM1-36ED1 Wiring, Continued

Discrete Input Specifications

| Discrete Input Specifications | | | |
|-------------------------------|------------------------------|-----------------------|-------------------|
| Input Type | Sink/Source | | |
| Total Inputs per Module | 20 | | |
| Commons | 5 (4 points/common) Isolated | | |
| Nominal Voltage Range | 12–24 VAC/VDC | | |
| Input Voltage Range | 9–30 VAC/VDC | | |
| Maximum Voltage | 30 VAC/VDC | | |
| DC Frequency | 0–250 kHz - High-speed | | |
| Minimum Pulse Width | 0.5 μ s - High-speed | | |
| AC Frequency | 47–63 Hz ² | | |
| Input Impedance | 3k Ω @ 24VDC | | |
| Input Current (typical) | 6mA @ 24 VAC/VDC | | |
| Maximum Input Current | 12mA @ 30 VAC/VDC | | |
| ON Voltage Level | > 9.0 VAC/VDC | | |
| OFF Voltage Level | < 2.0 VAC/VDC | | |
| Maximum OFF Current | 1.5 mA | | |
| Status Indicators | Logic Side, Green | | |
| Input Details | | | |
| Input Type | High-Speed DC | Standard ¹ | |
| Location | X0...X9 | X10...X19 | |
| OFF to ON Response | DC | < 2 μ s | 2ms |
| | AC | – | 10ms ² |
| ON to OFF Response | DC | < 2 μ s | 2ms |
| | AC | – | 10ms ² |
| Maximum Switching Frequency | DC | 250kHz | |
| | AC | ~ 30Hz | |

- 1. All inputs may be used as standard inputs. Only the first 10 inputs (X0...X9) are capable of high-speed DC operation.*
- 2. 60Hz to 240Hz filter should be set in the software when using an AC line signal.*

BX-DM1-36ED1 Wiring, Continued

Discrete Input Connection Options

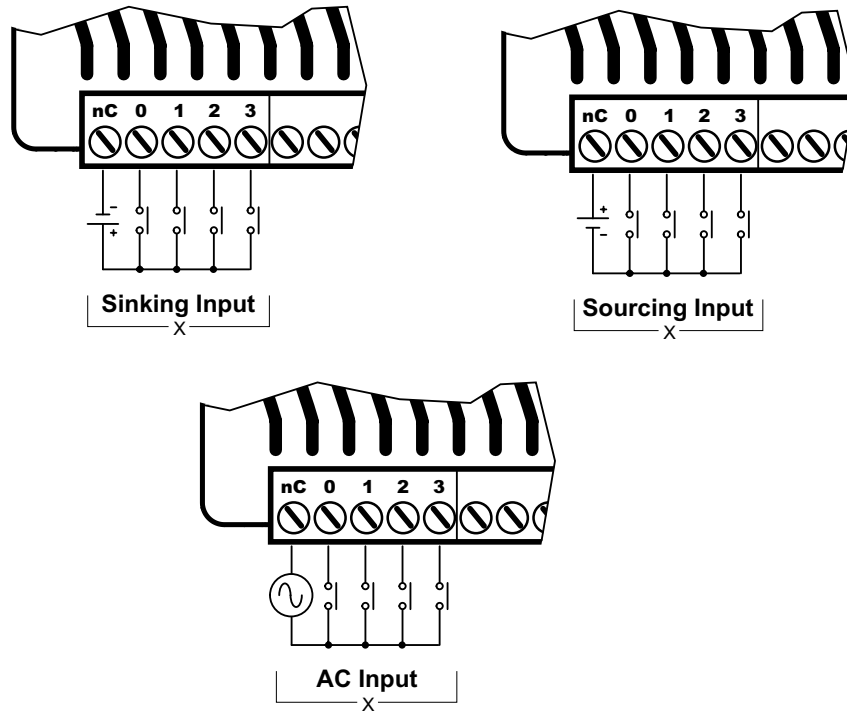

Discrete Input Internal Circuitry *

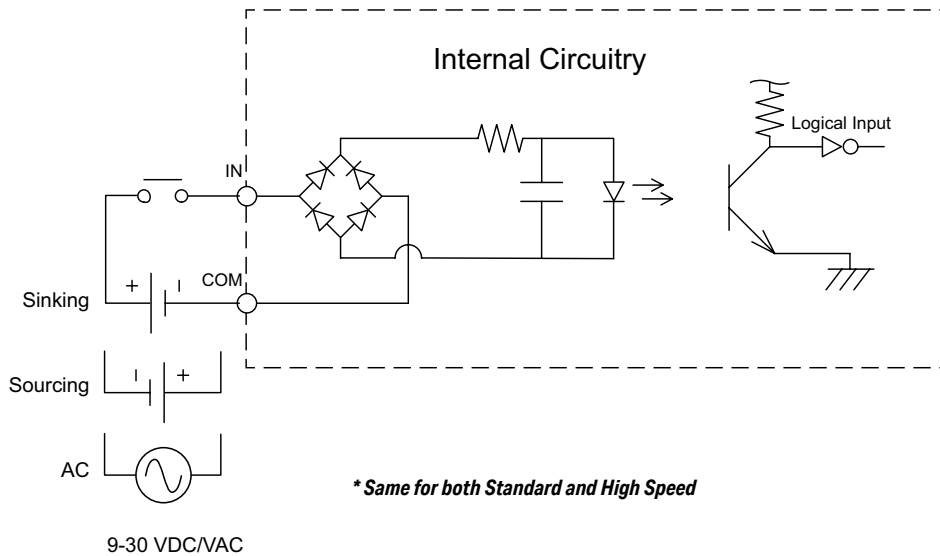

BX-DM1-36ED1 Wiring, Continued

Discrete Output Specifications

| Discrete Output Specifications | | |
|---|--|-----------------------|
| Output Type | Sinking | |
| Total Outputs per Module | 16 | |
| Commons | 4 (4 points/common) Isolated | |
| Maximum Current per Common | 2A | |
| Nominal Voltage Range | 12–24 VDC | |
| Operating Voltage Range | 5–36 VDC | |
| Maximum Voltage | 36VDC | |
| Minimum Output Current | 0.1 mA @ 24VDC | |
| Maximum Output Current | 0.5 A per output No derating over temperature range | |
| Maximum Inrush Current | 5A for 50ms | |
| Maximum Leakage Current | 10 μ A | |
| ON Voltage Drop | 0.05 VDC | |
| Status Indicators | Logic Side, Green | |
| Output Details | | |
| Output Type | High-Speed | Standard ¹ |
| Location | Y0...Y7 | Y8...Y15 |
| OFF to ON Response | < 2 μ s | < 5ms |
| ON to OFF Response | < 2 μ s | < 2ms |
| Maximum Switching Frequency | 1m cable - 250kHz 10m cable - 100kHz | ~100Hz |
| Overcurrent, Short Circuit Protection and Short to Ground | Current limit by Common Group, self-resetting | N/A |
| Overcurrent Trip Level ² | Between 4A and 8A | N/A |
| Fuse Type | User-supplied external fuse | |

1. All outputs may be used as standard outputs. Only the first 8 outputs (Y0...Y7) are capable of high-speed DC operation.

2. When the high-speed outputs are in an overcurrent situation, the Common terminal Red LED is on. The output LEDs will remain operational even though the output circuitry is turned off and no power is flowing. This condition is not reported to the CPU.

BX-DM1-36ED1 Wiring, continued

Discrete Output Connection Options

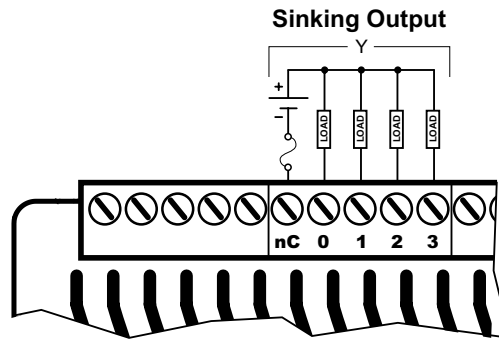

Discrete Standard Output Internal Circuitry

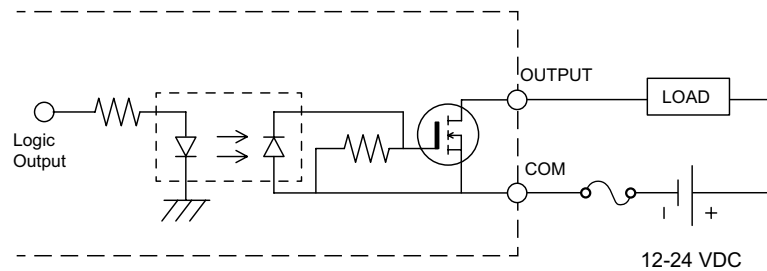

Discrete High-Speed Output Internal Circuitry

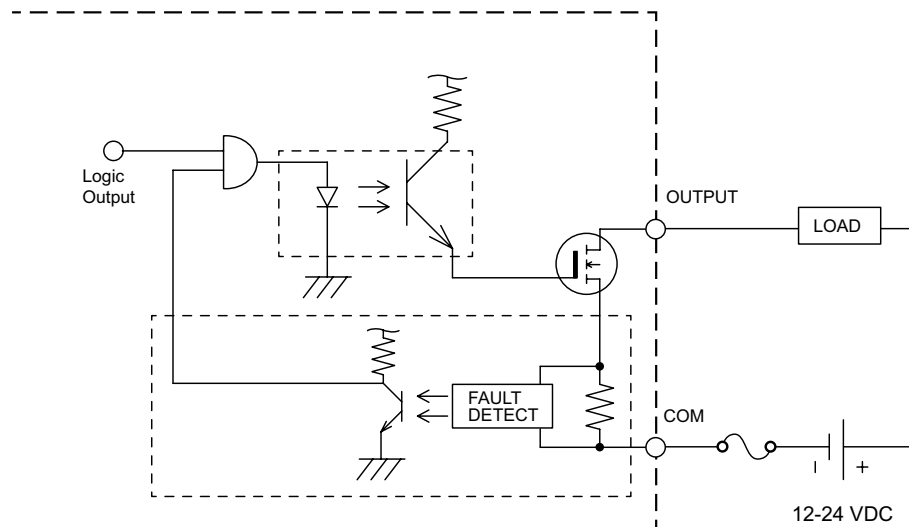

NOTE: When the high speed outputs are in an overcurrent situation, the Common terminal Red LED is on. The output LEDs will remain operational even though the output circuitry is turned off and no power is flowing. This condition is not reported to the CPU.

BX-DM1-36ED1-D Wiring

This MPU is made up of 36 discrete I/O points. The connections are grouped as follows:

- 20 discrete inputs - sinking/sourcing; rated for 12–24 VAC/VDC. They are located along the bottom of the unit; configured in five (5) groups of 5 terminals, each comprised of 4 inputs and an isolated common.
- 16 discrete outputs - sinking; rated at 12–24 VDC. They are located along the top of the unit starting to the right of the 24VDC external power supply terminals. The outputs are configured in four (4) groups of five (5) terminals, each comprised of four (4) outputs and an isolated common.

The MPU requires an external 12–24 VDC power supply. The DC power supply connection is located on the top left side of the unit. There is no 24VDC auxiliary output supply.



WARNING: No analog I/O is included on this unit. The 5 terminals to the right of the input and output rails are not used. These terminals are not internally connected. DO NOT CONNECT ANYTHING TO THESE TERMINALS!

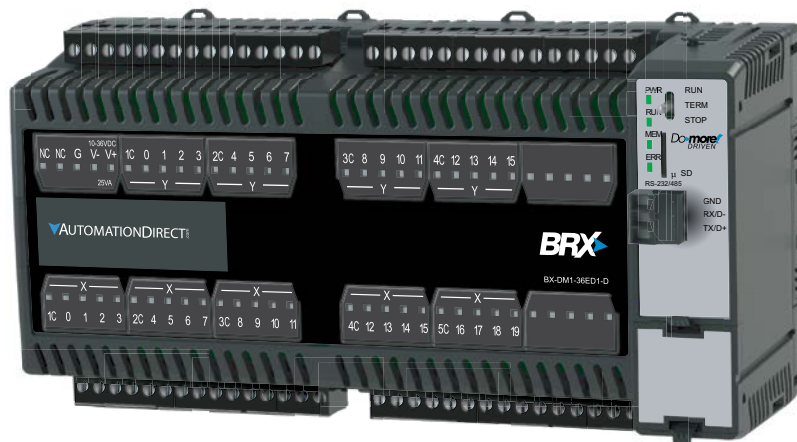

BX-DM1-36ED1-D



NOTE: Four (4) Expansion Modules can be connected to extend I/O capacity.

BX-DM1-36ED1-D Wiring, Continued

Power Supply Specifications

| Power Supply Specifications | |
|-------------------------------------|---|
| Nominal Voltage Range* | 12–24 VDC |
| Input Voltage Range (Tolerance)* | 10–36 VDC |
| Maximum Input Voltage Ripple | < ±10% |
| Maximum Input Power | 30W |
| Cold Start Inrush Current | 5A, 2ms |
| Maximum Inrush Current (Hot Start) | 5A, 2ms |
| Internal Input Protection | Reverse polarity protection and undervoltage lockout via transistor circuit |
| Acceptable External Power Drop Time | 10ms |
| Under Input Voltage Lock-out | <9VDC |
| Heat Dissipation | 19.5 W Max |
| Isolated User 24VDC Output | None |
| Voltage Withstand (dielectric) | 1500VAC power Inputs to ground applied for 1 minute |
| Insulation Resistance | >10MΩ @ 500VDC |
| Software Version Required | Do-more! Designer version 2.0 or later |

* Class 2 or LPS Power Supply required.

Power Supply Connections

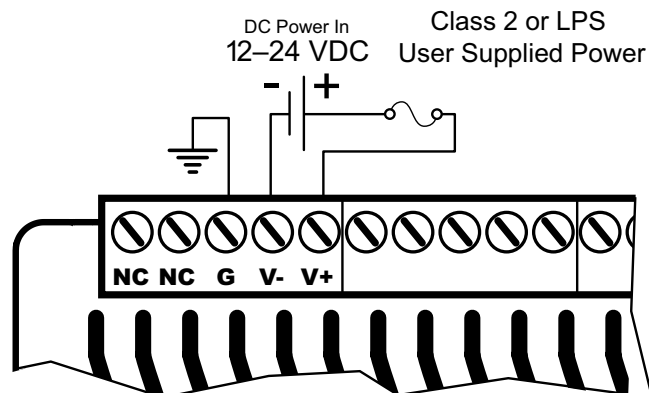

WARNING: No External AC power supply needed on this unit. The two terminals marked "NC" are not used. These terminals are not internally connected. **DO NOT CONNECT ANYTHING TO THESE TERMINALS!**



WARNING: The BRX System **MUST** have a proper earth ground. Do not operate the BRX MPU without proper earth grounding.

BX-DM1-36ED1-D Wiring, Continued

Discrete Input Specifications

| Discrete Input Specifications | | | |
|-------------------------------|------------------------------|-----------------------|-------------------|
| Input Type | Sink/Source | | |
| Total Inputs per Module | 20 | | |
| Commons | 5 (4 points/common) Isolated | | |
| Nominal Voltage Range | 12–24 VAC/VDC | | |
| Input Voltage Range | 9–30 VAC/VDC | | |
| Maximum Voltage | 30 VAC/VDC | | |
| DC Frequency | 0–250 kHz - High-speed | | |
| Minimum Pulse Width | 0.5 μ s - High-speed | | |
| AC Frequency | 47–63 Hz ² | | |
| Input Impedance | 3k Ω @ 24VDC | | |
| Input Current (typical) | 6mA @ 24 VAC/VDC | | |
| Maximum Input Current | 12mA @ 30 VAC/VDC | | |
| ON Voltage Level | > 9.0 VAC/VDC | | |
| OFF Voltage Level | < 2.0 VAC/VDC | | |
| Maximum OFF Current | 1.5 mA | | |
| Status Indicators | Logic Side, Green | | |
| Input Details | | | |
| Input Type | High-Speed DC | Standard ¹ | |
| Location | X0...X9 | X10...X19 | |
| OFF to ON Response | DC | < 2 μ s | 2ms |
| | AC | – | 10ms ² |
| ON to OFF Response | DC | < 2 μ s | 2ms |
| | AC | – | 10ms ² |
| Maximum Switching Frequency | DC | 250kHz | |
| | AC | ~ 30Hz | |

1. All inputs may be used as standard inputs. Only the first 10 inputs (X0...X9) are capable of high-speed DC operation.

2. 60Hz to 240Hz filter should be set in the software when using an AC line signal.

BX-DM1-36ED1-D Wiring, Continued

Discrete Input Connection Options

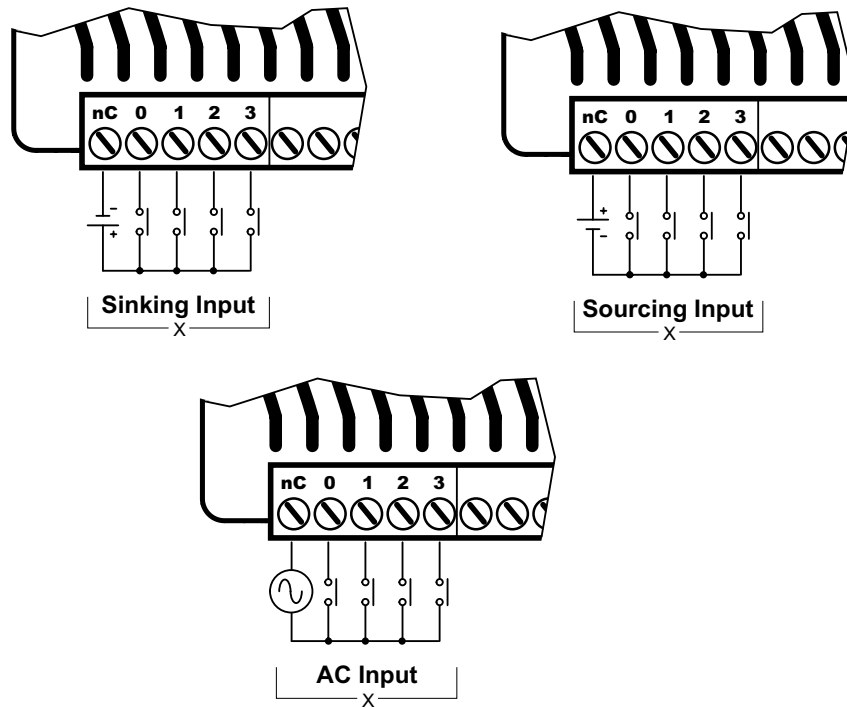

Discrete Input Internal Circuitry *

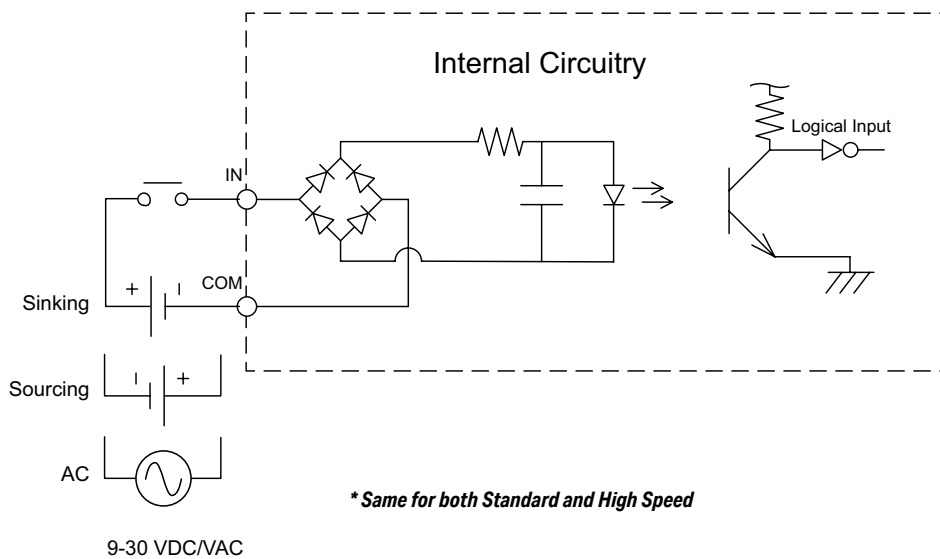

BX-DM1-36ED1-D Wiring, Continued

Discrete Output Specifications

| Discrete Output Specifications | | |
|---|--|-----------------------|
| Output Type | Sinking | |
| Total Outputs per Module | 16 | |
| Commons | 4 (4 points/common) Isolated | |
| Maximum Current per Common | 2A | |
| Nominal Voltage Range | 12–24 VDC | |
| Operating Voltage Range | 5–36 VDC | |
| Maximum Voltage | 36VDC | |
| Minimum Output Current | 0.1 mA @ 24VDC | |
| Maximum Output Current | 0.5 A per output No derating over temperature range | |
| Maximum Inrush Current | 5A for 50ms | |
| Maximum Leakage Current | 10 μ A | |
| ON Voltage Drop | 0.05 VDC | |
| Status Indicators | Logic Side, Green | |
| Output Details | | |
| Output Type | High-Speed | Standard ¹ |
| Location | Y0...Y7 | Y8...Y15 |
| OFF to ON Response | < 2 μ s | < 5ms |
| ON to OFF Response | < 2 μ s | < 2ms |
| Maximum Switching Frequency | 1m cable - 250kHz 10m cable - 100kHz | ~100Hz |
| Overcurrent, Short Circuit Protection and Short to Ground | Current limit by Common Group, self-resetting | N/A |
| Overcurrent Trip Level ² | Between 4A and 8A | N/A |
| Fuse Type | User-supplied external fuse | |

- 1. All outputs may be used as standard outputs. Only the first 8 outputs (Y0...Y7) are capable of high-speed DC operation.*
- 2. When the high-speed outputs are in an overcurrent situation, the Common terminal Red LED is on. The output LEDs will remain operational even though the output circuitry is turned off and no power is flowing. This condition is not reported to the CPU.*

BX-DM1-36ED1-D Wiring, Continued

Discrete Output Connection Options

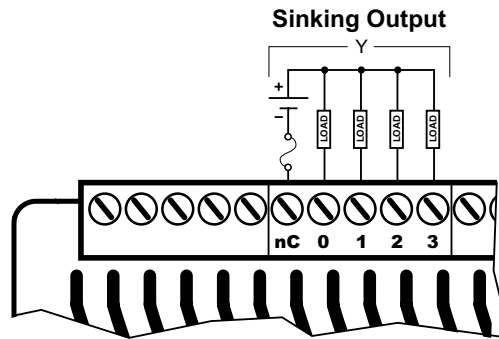

Discrete Standard Output Internal Circuitry

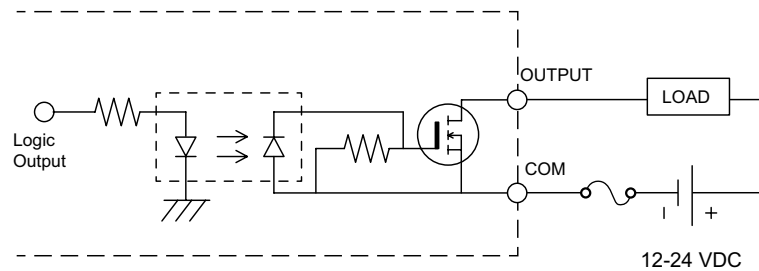

Discrete High-Speed Output Internal Circuitry

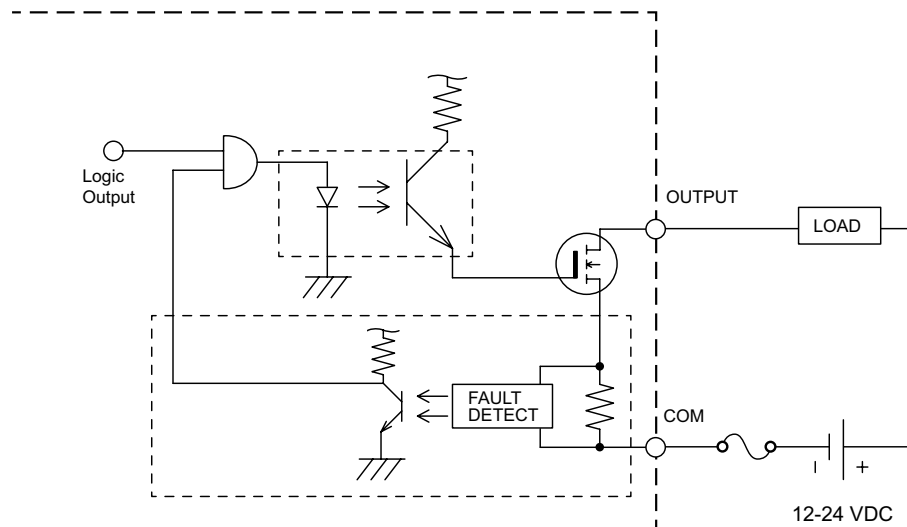

NOTE: When the high speed outputs are in an overcurrent situation, the Common terminal Red LED is on. The output LEDs will remain operational even though the output circuitry is turned off and no power is flowing. This condition is not reported to the CPU.

BX-DM1-36ED2 Wiring

This MPU is made up of 36 discrete I/O points. The connections are grouped as follows:

- 20 discrete inputs - sinking/sourcing; rated for 12–24 VAC/VDC. They are located along the bottom of the unit; configured in five (5) groups of 5 terminals, each comprised of 4 inputs and an isolated common.
- 16 discrete outputs - sourcing; rated at 12–24 VDC. They are located along the top of the unit starting to the right of the 24VDC auxiliary output terminals. The outputs are configured in four (4) groups of 5 terminals, each comprised of 4 outputs and an isolated common.

This MPU requires an external 120–240 VAC power supply. The AC power supply connection and the 24VDC auxiliary output supply terminals are located on the top left side of the unit.



WARNING: No analog I/O is included on this unit. The 5 terminals to the right of the input and output rails are not used. These terminals are not internally connected. DO NOT CONNECT ANYTHING TO THESE TERMINALS!

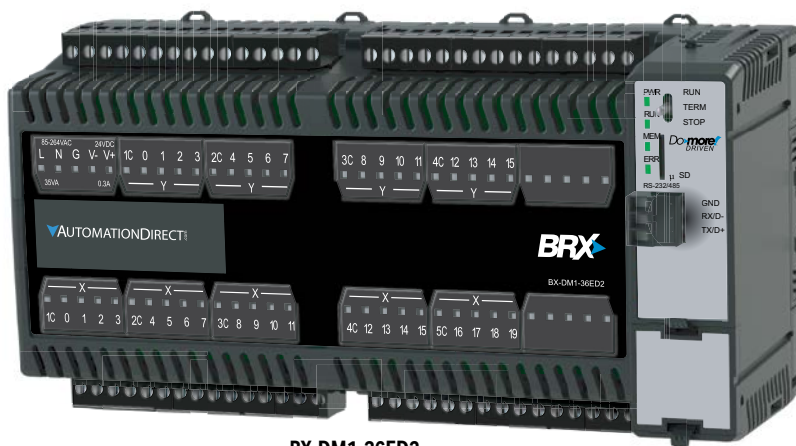

BX-DM1-36ED2



NOTE: Four (4) Expansion Modules can be connected to extend I/O capacity.

BX-DM1-36ED2 Wiring, Continued

Power Supply Specifications

| Power Supply Specifications | |
|-------------------------------------|--|
| Nominal Voltage Range | 120–240 VAC |
| Input Voltage Range (Tolerance) | 85–264 VAC |
| Rated Operating Frequency | 47–63 Hz |
| Maximum Input Power | 40VA |
| Cold Start Inrush Current | 1.5 A, 2ms |
| Maximum Inrush Current (Hot Start) | 1.5 A, 2ms |
| Internal Input Fuse Protection | Micro fuse 250V, 2A Non-replaceable |
| Acceptable External Power Drop Time | 10ms |
| Under Input Voltage Lock-out | 80VAC |
| Input Transient Protection | Input choke and line filter |
| Heat Dissipation | 21.7 W Max |
| Isolated User 24VDC Output | 24VDC @ 0.3 A max, <1V P-P Ripple, Integrated self-resetting short circuit protection |
| Voltage Withstand (dielectric) | 1500VAC Power Inputs to Ground applied for 1 minute 1500VAC Ground to 24VDC Output applied for 1 minute |
| Insulation Resistance | >10M Ω @ 500VDC |
| Software Version Required | Do-more! Designer version 2.0 or later |

Power Supply Connections

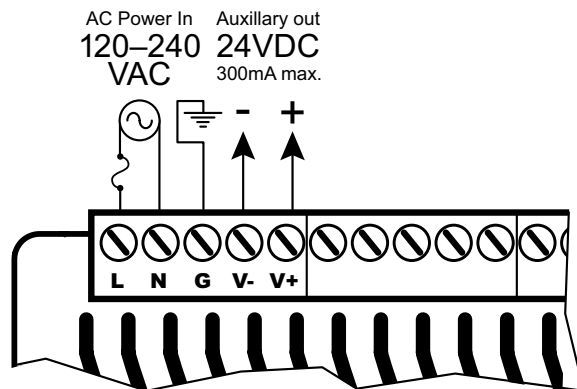

WARNING: Do not exceed the 24VDC auxiliary power supply load limit of 300mA.



WARNING: The BRX System MUST have a proper earth ground. Do not operate the BRX MPU without proper earth grounding.

BX-DM1-36ED2 Wiring, Continued

Discrete Input Specifications

| Discrete Input Specifications | | | |
|-------------------------------|------------------------------|-------------|-----------------------|
| Input Type | Sink/Source | | |
| Total Inputs per Module | 20 | | |
| Commons | 5 (4 points/common) Isolated | | |
| Nominal Voltage Range | 12–24 VAC/VDC | | |
| Input Voltage Range | 9–30 VAC/VDC | | |
| Maximum Voltage | 30 VAC/VDC | | |
| DC Frequency | 0–250 kHz - High-speed | | |
| Minimum Pulse Width | 0.5 μ s - High-speed | | |
| AC Frequency | 47–63 Hz ² | | |
| Input Impedance | 3k Ω @ 24VDC | | |
| Input Current (typical) | 6mA @ 24 VAC/VDC | | |
| Maximum Input Current | 12mA @ 30 VAC/VDC | | |
| ON Voltage Level | > 9.0 VAC/VDC | | |
| OFF Voltage Level | < 2.0 VAC/VDC | | |
| Maximum OFF Current | 1.5 mA | | |
| Status Indicators | Logic Side, Green | | |
| Input Details | | | |
| Input Type | High-Speed DC | | Standard ¹ |
| Location | X0...X9 | | X10...X19 |
| OFF to ON Response | DC | < 2 μ s | 2ms |
| | AC | – | 10ms ² |
| ON to OFF Response | DC | < 2 μ s | 2ms |
| | AC | – | 10ms ² |
| Maximum Switching Frequency | DC | 250kHz | |
| | AC | ~ 30Hz | |

1. All inputs may be used as standard inputs. Only the first 10 inputs (X0...X9) are capable of high-speed DC operation.

2. 60Hz to 240Hz filter should be set in the software when using an AC line signal.

BX-DM1-36ED2 Wiring, Continued

Discrete Input Connection Options

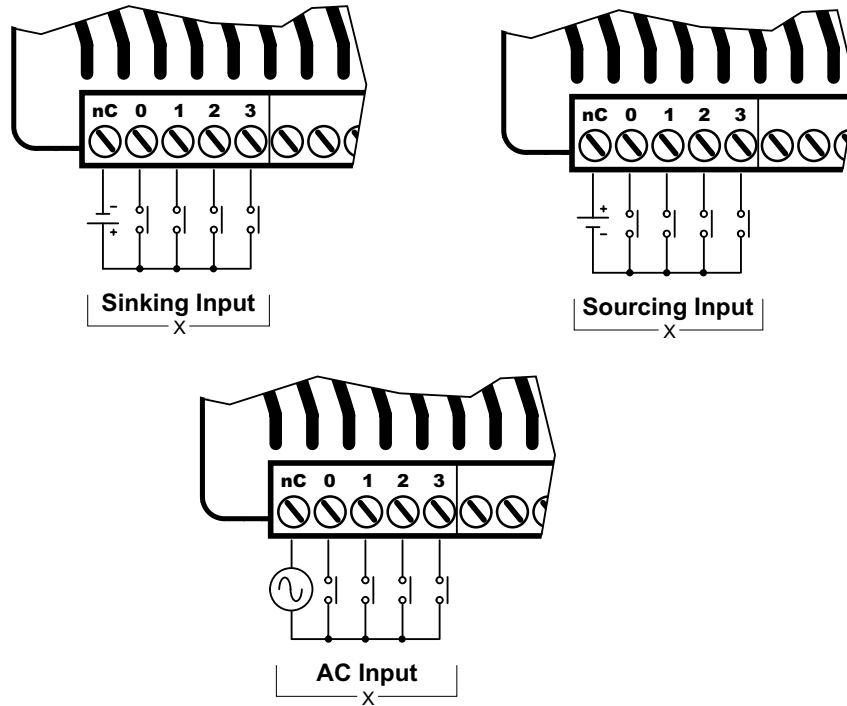

Discrete Input Internal Circuitry *

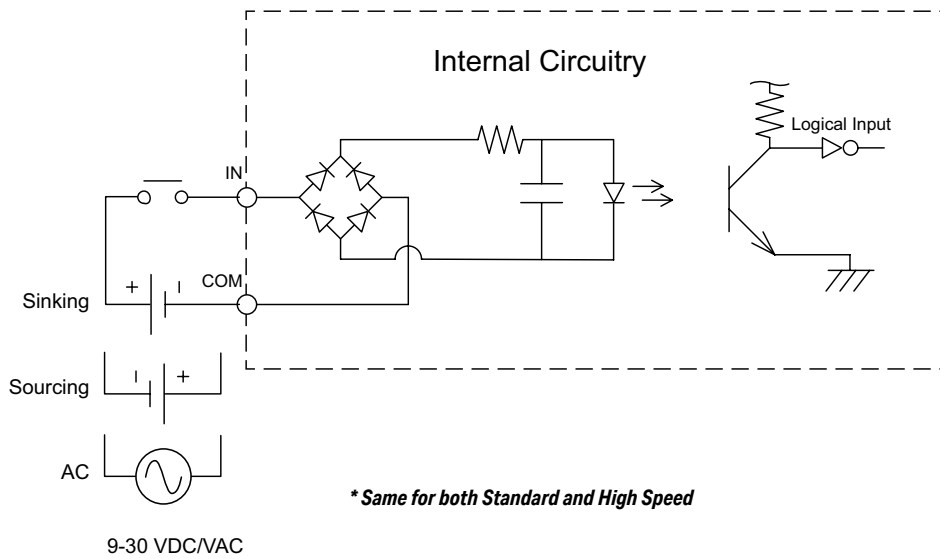

BX-DM1-36ED2 Wiring, Continued

Discrete Output Specifications

| Discrete Output Specifications | | |
|---|--|-----------------------|
| Output Type | Sourcing | |
| Total Outputs per Module | 16 | |
| Commons | 4 (4 points/common) Isolated | |
| Maximum Current per Common | 2A | |
| Nominal Voltage Range | 12–24 VDC | |
| Operating Voltage Range | 5–36 VDC | |
| Maximum Voltage | 36VDC | |
| Minimum Output Current | 0.1 mA @ 24VDC | |
| Maximum Output Current | 0.5 A per output No derating over temperature range | |
| Maximum Inrush Current | 5A for 50ms | |
| Maximum Leakage Current | 10 μ A | |
| ON Voltage Drop | 0.05 VDC | |
| Status Indicators | Logic Side, Green | |
| Output Details | | |
| Output Type | High-Speed | Standard ¹ |
| Location | Y0...Y7 | Y8...Y15 |
| OFF to ON Response | < 2 μ s | < 5ms |
| ON to OFF Response | < 2 μ s | < 2ms |
| Maximum Switching Frequency | 1m cable - 250kHz 10m cable - 100kHz | ~100Hz |
| Overcurrent, Short Circuit Protection and Short to Ground | Current limit by Common Group, self-resetting | N/A |
| Overcurrent Trip Level ² | Between 4A and 8A | N/A |
| Fuse Type | User-supplied external fuse | |

- 1. All outputs may be used as standard outputs. Only the first 8 outputs (Y0...Y7) are capable of high-speed DC operation.*
- 2. When the high-speed outputs are in an overcurrent situation, the Common terminal Red LED is on. The output LEDs will remain operational even though the output circuitry is turned off and no power is flowing. This condition is not reported to the CPU.*

BX-DM1-36ED2 Wiring, Continued

Discrete Output Connection Options

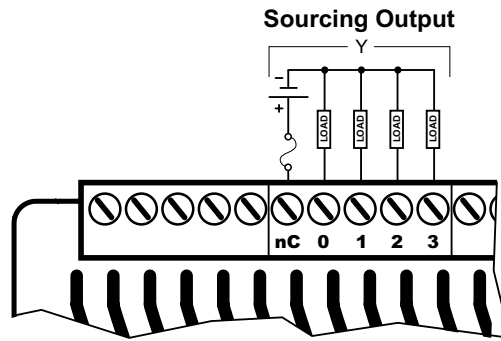

Discrete Standard Output Internal Circuitry

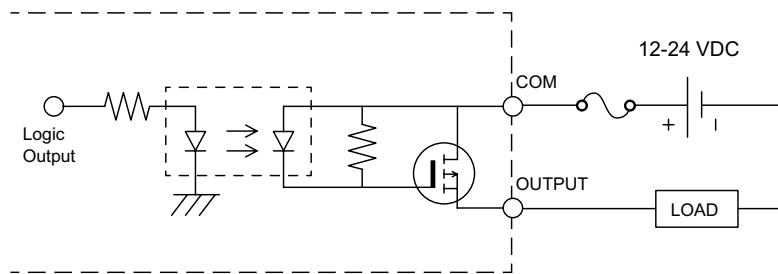

Discrete High-Speed Output Internal Circuitry

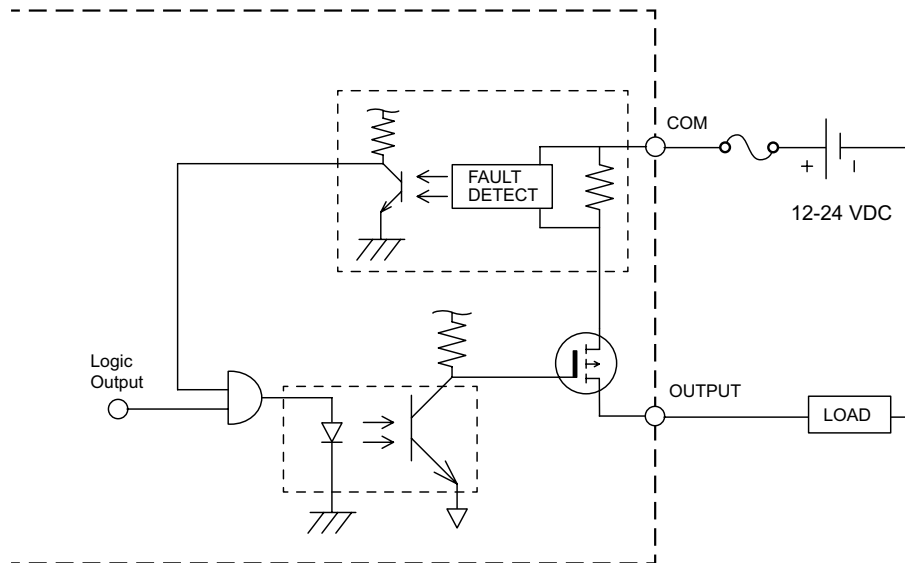

NOTE: When the high speed outputs are in an overcurrent situation, the Common terminal Red LED is on. The output LEDs will remain operational even though the output circuitry is turned off and no power is flowing. This condition is not reported to the CPU.

BX-DM1-36ED2-D Wiring

This MPU is made up of 36 discrete I/O points. The connections are grouped as follows:

- 20 discrete inputs - sinking/sourcing; rated for 12–24 VAC/VDC. They are located along the bottom of the unit; configured in five (5) groups of 5 terminals, each comprised of 4 inputs and an isolated common.
- 16 discrete outputs - sourcing; rated at 12–24 VDC. They are located along the top of the unit starting to the right of the 24VDC external power supply terminals. The outputs are configured in four (4) groups of 5 terminals, each comprised of 4 outputs and an isolated common.

This MPU requires an external 12–24 VDC power supply. The DC power supply connection is located on the top left side of the unit. There is no 24VDC auxiliary output supply.



WARNING: No analog I/O is included on this unit. The 5 terminals to the right of the input and output rails are not used. These terminals are not internally connected. DO NOT CONNECT ANYTHING TO THESE TERMINALS!

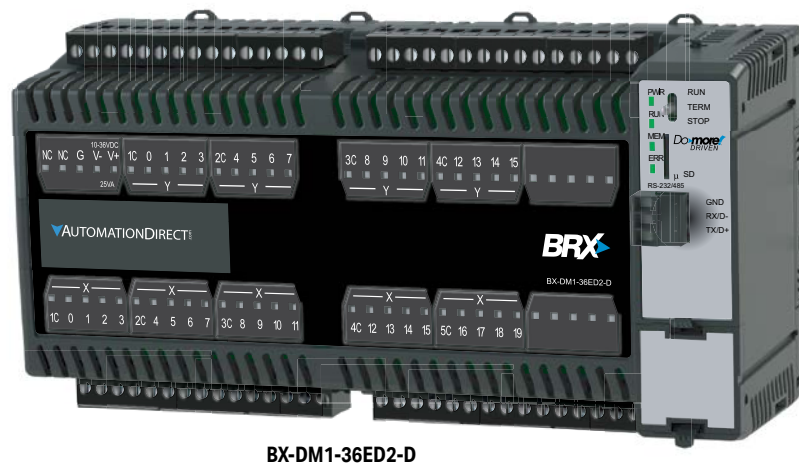

BX-DM1-36ED2-D



NOTE: Four (4) Expansion Modules can be connected to extend I/O capacity.

BX-DM1-36ED2-D, Continued

Power Supply Specifications

| Power Supply Specifications | |
|-------------------------------------|---|
| Nominal Voltage Range* | 12–24 VDC |
| Input Voltage Range (Tolerance)* | 10–36 VDC |
| Maximum Input Voltage Ripple | < ±10% |
| Maximum Input Power | 30W |
| Cold Start Inrush Current | 5A, 2ms |
| Maximum Inrush Current (Hot Start) | 5A, 2ms |
| Internal Input Protection | Reverse polarity protection and undervoltage lockout via transistor circuit |
| Acceptable External Power Drop Time | 10ms |
| Under Input Voltage Lock-out | <9VDC |
| Heat Dissipation | 19.5 W Max |
| Isolated User 24VDC Output | None |
| Voltage Withstand (dielectric) | 1500VAC power Inputs to ground applied for 1 minute |
| Insulation Resistance | >10MΩ @ 500VDC |
| Software Version Required | Do-more! Designer version 2.0 or later |

*Class 2 or LPS Power Supply required.

Power Supply Connections

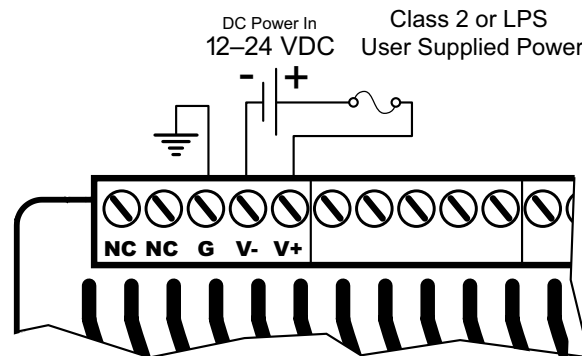

WARNING: No External AC power supply needed on this unit. The two terminals marked "NC" are not used. These terminals are not internally connected. **DO NOT CONNECT ANYTHING TO THESE TERMINALS!**



WARNING: The BRX System **MUST** have a proper earth ground. Do not operate the BRX MPU without proper earth grounding.

BX-DM1-36ED2-D Wiring, Continued

Discrete Input Specifications

| Discrete Input Specifications | | | |
|-------------------------------|------------------------------|-------------|-----------------------|
| Input Type | Sink/Source | | |
| Total Inputs per Module | 20 | | |
| Commons | 5 (4 points/common) Isolated | | |
| Nominal Voltage Range | 12–24 VAC/VDC | | |
| Input Voltage Range | 9–30 VAC/VDC | | |
| Maximum Voltage | 30 VAC/VDC | | |
| DC Frequency | 0–250 kHz - High-speed | | |
| Minimum Pulse Width | 0.5 μ s - High-speed | | |
| AC Frequency | 47–63 Hz ² | | |
| Input Impedance | 3k Ω @ 24VDC | | |
| Input Current (typical) | 6mA @ 24 VAC/VDC | | |
| Maximum Input Current | 12mA @ 30 VAC/VDC | | |
| ON Voltage Level | > 9.0 VAC/VDC | | |
| OFF Voltage Level | < 2.0 VAC/VDC | | |
| Maximum OFF Current | 1.5 mA | | |
| Status Indicators | Logic Side, Green | | |
| Input Details | | | |
| Input Type | High-Speed DC | | Standard ¹ |
| Location | X0...X9 | | X10...X19 |
| OFF to ON Response | DC | < 2 μ s | 2ms |
| | AC | – | 10ms ² |
| ON to OFF Response | DC | < 2 μ s | 2ms |
| | AC | – | 10ms ² |
| Maximum Switching Frequency | DC | 250kHz | |
| | AC | ~ 30Hz | |

1. All inputs may be used as standard inputs. Only the first 10 inputs (X0...X9) are capable of high-speed DC operation.

2. 60Hz to 240Hz filter should be set in the software when using an AC line signal.

BX-DM1-36ED2-D Wiring, Continued

Discrete Input Connection Options

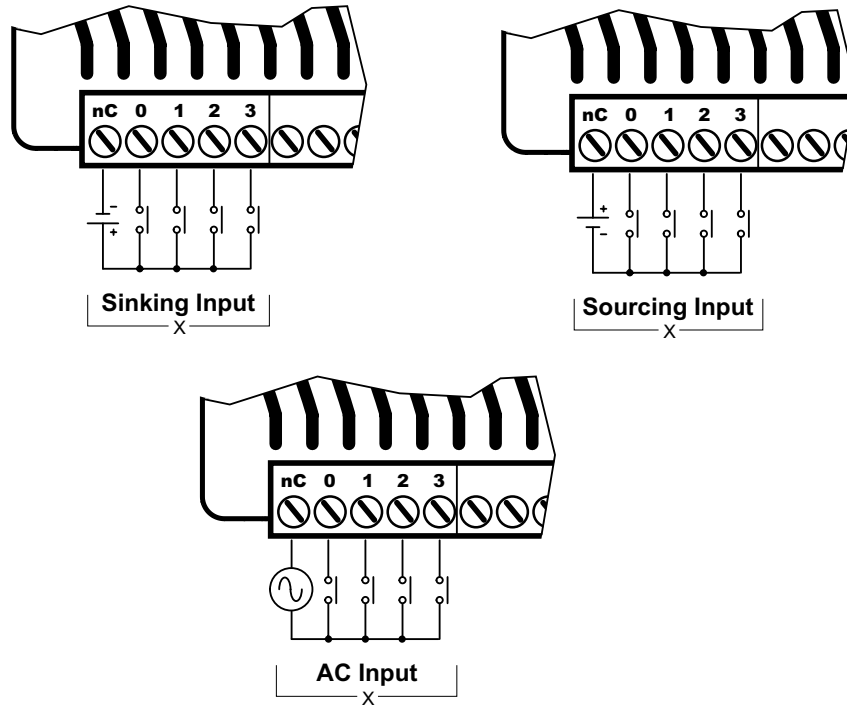

Discrete Input Internal Circuitry *

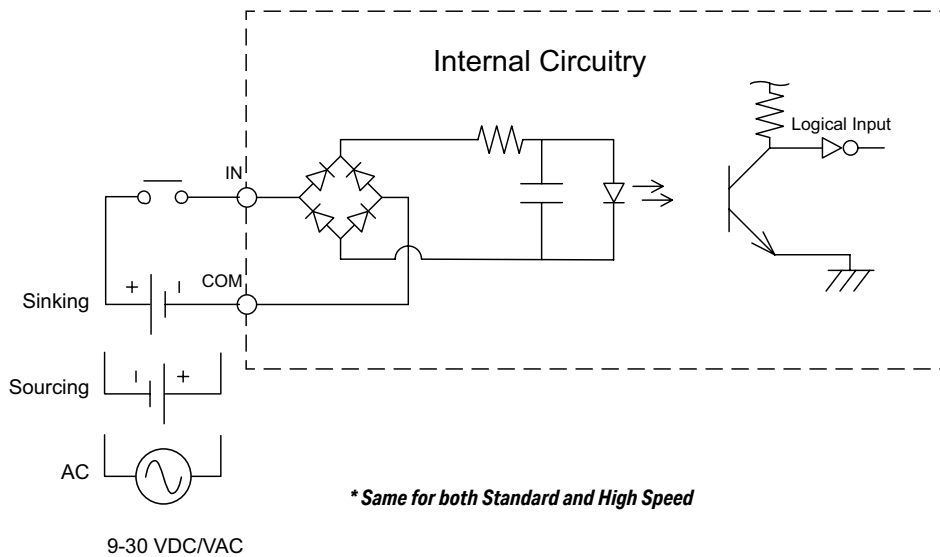

BX-DM1-36ED2-D Wiring, Continued

Discrete Output Specifications

| Discrete Output Specifications | | |
|---|--|-----------------------|
| Output Type | Sourcing | |
| Total Outputs per Module | 16 | |
| Commons | 4 (4 points/common) Isolated | |
| Maximum Current per Common | 2A | |
| Nominal Voltage Range | 12–24 VDC | |
| Operating Voltage Range | 5–36 VDC | |
| Maximum Voltage | 36VDC | |
| Minimum Output Current | 0.1 mA @ 24VDC | |
| Maximum Output Current | 0.5 A per output No derating over temperature range | |
| Maximum Inrush Current | 5A for 50ms | |
| Maximum Leakage Current | 10 μ A | |
| ON Voltage Drop | 0.05 VDC | |
| Status Indicators | Logic Side, Green | |
| Output Details | | |
| Output Type | High-Speed | Standard ¹ |
| Location | Y0...Y7 | Y8...Y15 |
| OFF to ON Response | < 2 μ s | < 5ms |
| ON to OFF Response | < 2 μ s | < 2ms |
| Maximum Switching Frequency | 1m cable - 250kHz 10m cable - 100kHz | ~100Hz |
| Overcurrent, Short Circuit Protection and Short to Ground | Current limit by Common Group, self-resetting | N/A |
| Overcurrent Trip Level ² | Between 4A and 8A | N/A |
| Fuse Type | User-supplied external fuse | |

- 1. All outputs may be used as standard outputs. Only the first 8 outputs (Y0...Y7) are capable of high-speed DC operation.*
- 2. When the high-speed outputs are in an overcurrent situation, the Common terminal Red LED is on. The output LEDs will remain operational even though the output circuitry is turned off and no power is flowing. This condition is not reported to the CPU.*

BX-DM1-36ED2-D Wiring, Continued

Discrete Output Connection Options

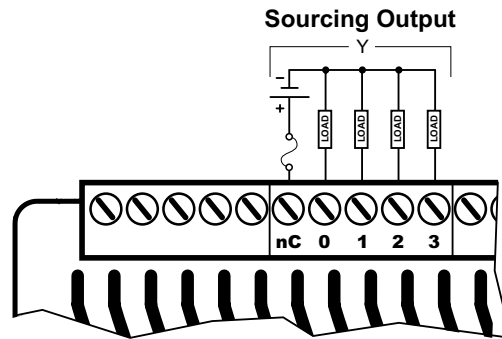

Discrete Standard Output Internal Circuitry

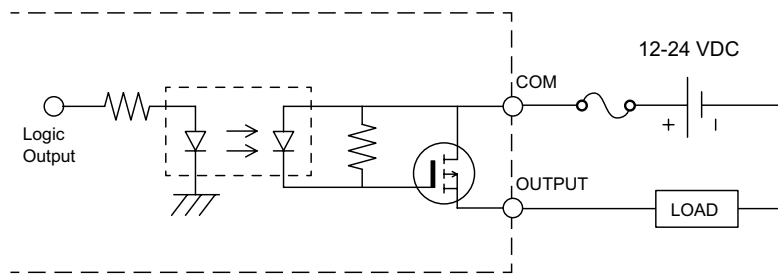

Discrete High-Speed Output Internal Circuitry

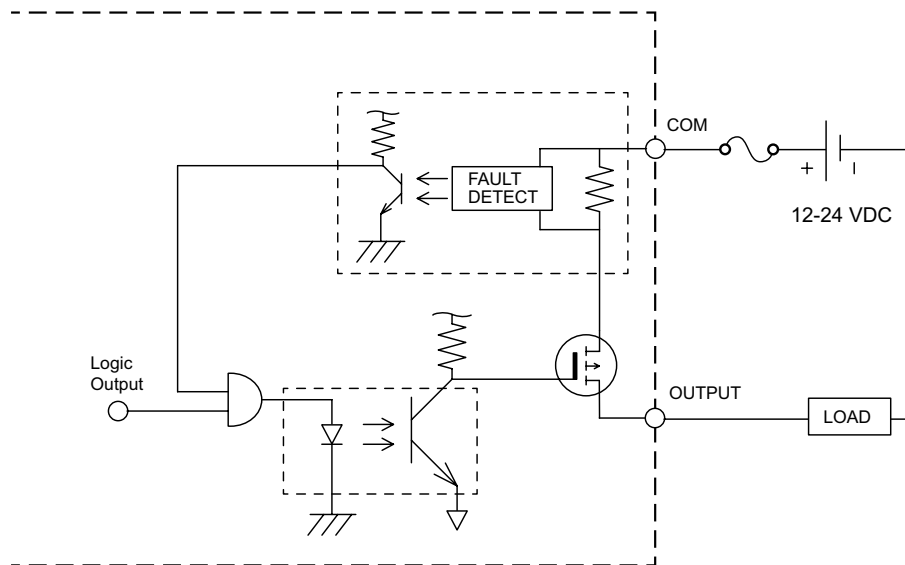

NOTE: When the high speed outputs are in an overcurrent situation, the Common terminal Red LED is on. The output LEDs will remain operational even though the output circuitry is turned off and no power is flowing. This condition is not reported to the CPU.

BX-DM1-36ER Wiring

This MPU is made up of 36 discrete I/O points. The connections are grouped as follows:

- 20 discrete inputs - sinking/sourcing; rated for 12–24 VAC/VDC. They are located along the bottom of the unit; configured in five (5) groups of 5 terminals, each comprised of 4 inputs and an isolated common.
- 16 discrete outputs - Form A Relay (SPST); rated 12–48 VDC/ 24–240 VAC. They are located along the top of the unit starting to the right of the 24VDC auxiliary output terminals. The outputs are configured in four (4) groups of 5 terminals, each comprised of 4 outputs and an isolated common.

This MPU requires an external 120–240 VAC power supply. The AC power supply connection and the 24VDC auxiliary output supply terminals are located on the top left side of the unit.



WARNING: No analog I/O is included on this unit. The 5 terminals to the right of the input and output rails are not used. These terminals are not internally connected. DO NOT CONNECT ANYTHING TO THESE TERMINALS!

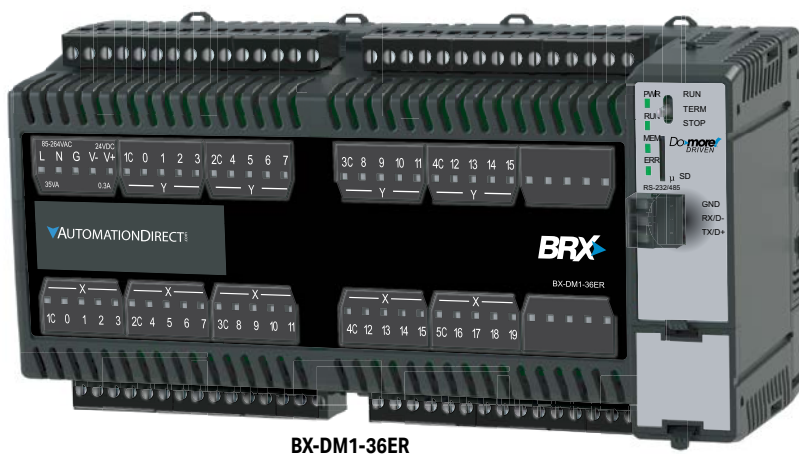

BX-DM1-36ER



NOTE: Four (4) Expansion Modules can be connected to extend I/O capacity.

BX-DM1-36ER Wiring, Continued

Power Supply Specifications

| Power Supply Specifications | |
|-------------------------------------|--|
| Nominal Voltage Range | 120–240 VAC |
| Input Voltage Range (Tolerance) | 85–264 VAC |
| Rated Operating Frequency | 47–63 Hz |
| Maximum Input Power | 40VA |
| Cold Start Inrush Current | 1.5 A, 2ms |
| Maximum Inrush Current (Hot Start) | 1.5 A, 2ms |
| Internal Input Fuse Protection | Micro fuse 250V, 2A Non-replaceable |
| Acceptable External Power Drop Time | 10ms |
| Under Input Voltage Lock-out | 80VAC |
| Input Transient Protection | Input choke and line filter |
| Heat Dissipation | 24.9 W Max |
| Isolated User 24VDC Output | 24VDC @ 0.3 A max, <1V P-P Ripple, Integrated self-resetting short circuit protection |
| Voltage Withstand (dielectric) | 1500VAC Power Inputs to Ground applied for 1 minute 1500VAC Ground to 24VDC Output applied for 1 minute |
| Insulation Resistance | >10MΩ @ 500VDC |
| Software Version Required | Do-more! Designer version 2.0 or later |

Power Supply Connections

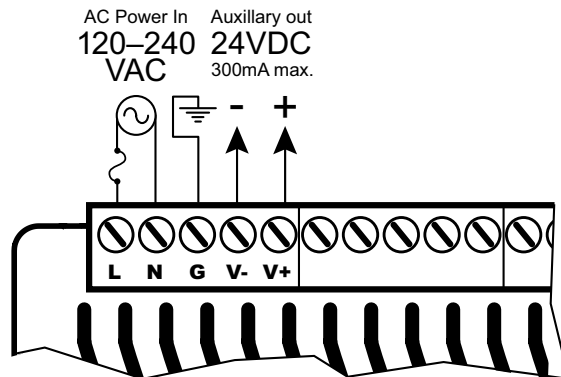

WARNING: Do not exceed the 24VDC auxiliary power supply load limit of 300mA.



WARNING: The BRX System **MUST** have a proper earth ground. Do not operate the BRX MPU without proper earth grounding.

BX-DM1-36ER Wiring, Continued

Discrete Input Specifications

| Discrete Input Specifications | | | |
|-------------------------------|------------------------------|-------------|-----------------------|
| Input Type | Sink/Source | | |
| Total Inputs per Module | 20 | | |
| Commons | 5 (4 points/common) Isolated | | |
| Nominal Voltage Range | 12–24 VAC/VDC | | |
| Input Voltage Range | 9–30 VAC/VDC | | |
| Maximum Voltage | 30 VAC/VDC | | |
| DC Frequency | 0–250 kHz - High-speed | | |
| Minimum Pulse Width | 0.5 μ s - High-speed | | |
| AC Frequency | 47–63 Hz ² | | |
| Input Impedance | 3k Ω @ 24VDC | | |
| Input Current (typical) | 6mA @ 24 VAC/VDC | | |
| Maximum Input Current | 12mA @ 30 VAC/VDC | | |
| ON Voltage Level | > 9.0 VAC/VDC | | |
| OFF Voltage Level | < 2.0 VAC/VDC | | |
| Maximum OFF Current | 1.5 mA | | |
| Status Indicators | Logic Side, Green | | |
| Input Details | | | |
| Input Type | High-Speed DC | | Standard ¹ |
| Location | X0...X9 | | X10...X19 |
| OFF to ON Response | DC | < 2 μ s | 2ms |
| | AC | – | 10ms ² |
| ON to OFF Response | DC | < 2 μ s | 2ms |
| | AC | – | 10ms ² |
| Maximum Switching Frequency | DC | 250kHz | |
| | AC | ~ 30Hz | |

- 1. All inputs may be used as standard inputs. Only the first 10 inputs (X0...X9) are capable of high-speed DC operation.*
- 2. 60Hz to 240Hz filter should be set in the software when using an AC line signal.*

BX-DM1-36ER Wiring, Continued

Discrete Input Connection Options

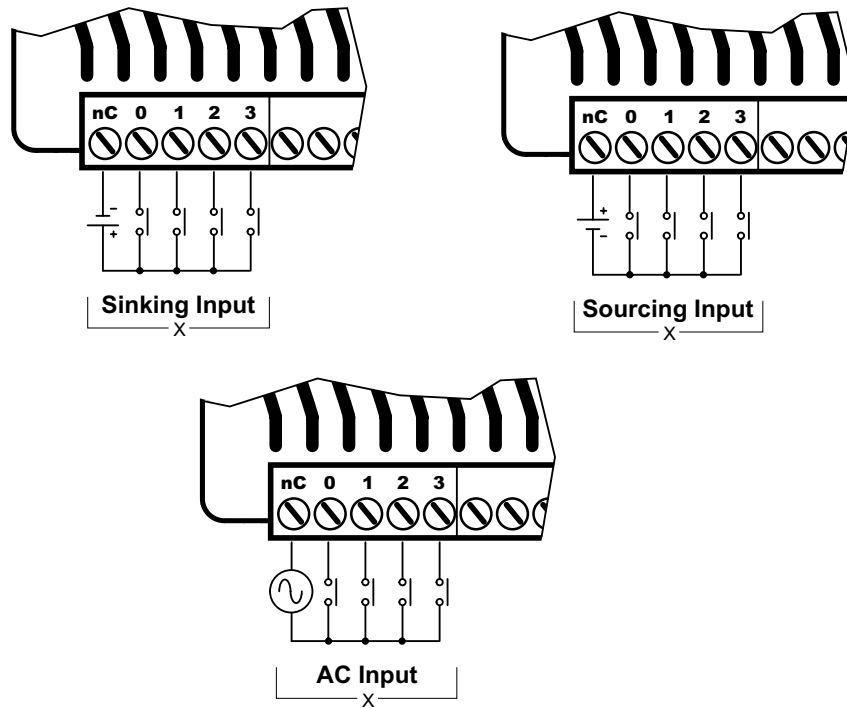

Discrete Input Internal Circuitry *

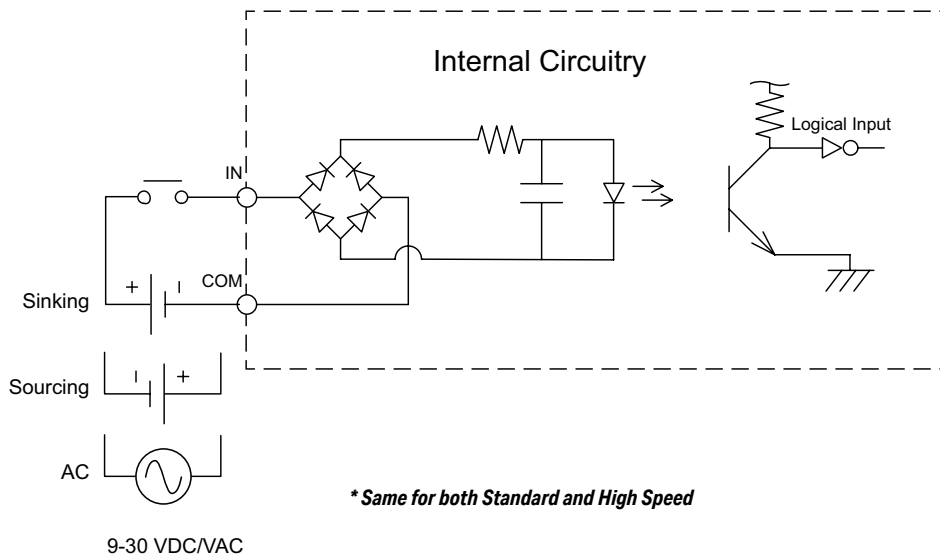

BX-DM1-36ER Wiring, Continued

Discrete Output Specifications

| Discrete Output Specifications | |
|--------------------------------|--|
| Output Type | Relay Form A (SPST) |
| Total Outputs per Module | 16 |
| Commons | 4 (4 points/common) Isolated |
| Maximum Current per Common | 8A |
| Nominal Voltage Range | 12–48 VDC 24–240 VAC |
| Operating Voltage Range | 5–60 VDC 5–264 VAC |
| Maximum Voltage | 60VDC 264VAC |
| Minimum Output Current | 0.1 mA @ 24VDC 0.1 mA @ 24VAC |
| Maximum Output Current | 2A |
| Maximum Inrush Current | 5A for 50ms |
| Maximum Leakage Current | 1 μ A (DC), 300 μ A (AC) due to RC snubber circuit |
| ON Voltage Drop | 0.2 V Max |
| Status Indicators | Logic Side, Green |
| Output Details | |
| Output Type | Standard |
| Location | Y0...Y15 |
| ON-OFF Response | <10ms |
| OFF-ON Response | <10ms |
| Maximum Switching Frequency | 10Hz |
| Relay Cycle Life | 5 million operations |
| Mechanical Endurance | 120,000 operations |
| Electrical Endurance | |
| Fuse Type | User-supplied external fuse |

BX-DM1-36ER Wiring, Continued

Discrete Output Connection Options

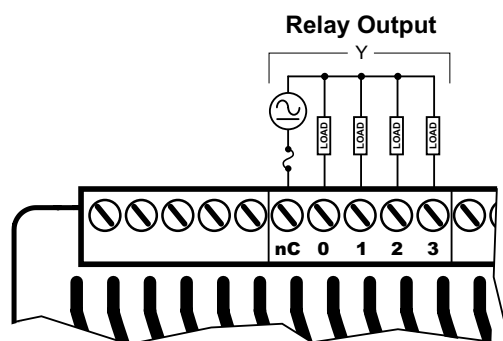

Discrete Standard Output Internal Circuitry

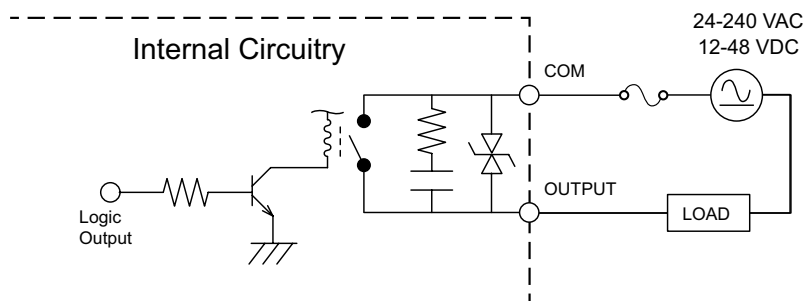

BX-DM1-36ER-D Wiring

This MPU is made up of 36 discrete I/O points. The connections are grouped as follows:

- 20 discrete inputs - sinking/sourcing; rated for 12–24 VAC/VDC. They are located along the bottom of the unit; configured in five (5) groups of 5 terminals, each comprised of 4 inputs and an isolated common.
- 16 discrete outputs - Form A Relay (SPST); rated 12–48 VDC/ 24–240 VAC. They are located along the top of the unit starting to the right of the 24VDC external power supply terminals. The outputs are configured in four (4) groups of 5 terminals, each comprised of 4 outputs and an isolated common.

This MPU requires an external 12–24 VDC power supply. The DC power supply connection is located on the top left side of the unit. There is no 24VDC auxiliary output supply



WARNING: No analog I/O is included on this unit. The 5 terminals to the right of the input and output rails are not used. These terminals are not internally connected. DO NOT CONNECT ANYTHING TO THESE TERMINALS!

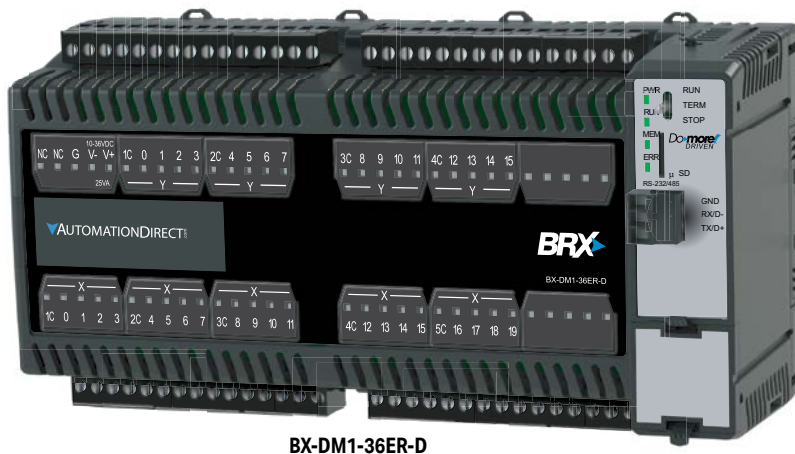

BX-DM1-36ER-D



NOTE: Four (4) Expansion Modules can be connected to extend I/O capacity.

BX-DM1-36ER-D Wiring, Continued

Power Supply Specifications

| Power Supply Specifications | |
|-------------------------------------|---|
| Nominal Voltage Range* | 12–24 VDC |
| Input Voltage Range (Tolerance)* | 10–36 VDC |
| Maximum Input Voltage Ripple | < ±10% |
| Maximum Input Power | 30W |
| Cold Start Inrush Current | 5A, 2ms |
| Maximum Inrush Current (Hot Start) | 5A, 2ms |
| Internal Input Protection | Reverse polarity protection and undervoltage lockout via transistor circuit |
| Acceptable External Power Drop Time | 10ms |
| Under Input Voltage Lock-out | <9VDC |
| Heat Dissipation | 22.7 W Max |
| Isolated User 24VDC Output | None |
| Voltage Withstand (dielectric) | 1500VAC power Inputs to ground applied for 1 minute |
| Insulation Resistance | >10MΩ @ 500VDC |
| Software Version Required | Do-more! Designer version 2.0 or later |

* Class 2 or LPS Power Supply required.

Power Supply Connections

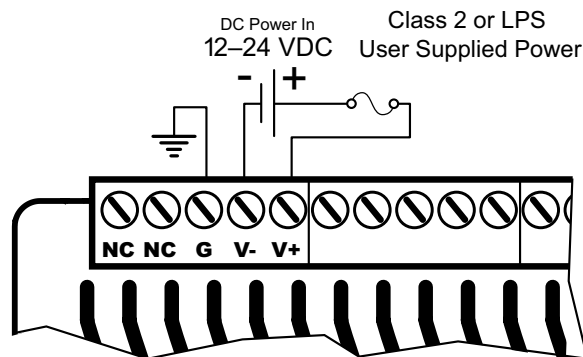

WARNING: No External AC power supply needed on this unit. The two terminals marked "NC" are not used. These terminals are not internally connected. **DO NOT CONNECT ANYTHING TO THESE TERMINALS!**



WARNING: The BRX System **MUST** have a proper earth ground. Do not operate the BRX MPU without proper earth grounding.

BX-DM1-36ER-D Wiring, Continued

Discrete Input Specifications

| Discrete Input Specifications | | | |
|-------------------------------|------------------------------|-------------|-----------------------|
| Input Type | Sink/Source | | |
| Total Inputs per Module | 20 | | |
| Commons | 5 (4 points/common) Isolated | | |
| Nominal Voltage Range | 12–24 VAC/VDC | | |
| Input Voltage Range | 9–30 VAC/VDC | | |
| Maximum Voltage | 30 VAC/VDC | | |
| DC Frequency | 0–250 kHz - High-speed | | |
| Minimum Pulse Width | 0.5 μ s - High-speed | | |
| AC Frequency | 47–63 Hz ² | | |
| Input Impedance | 3k Ω @ 24VDC | | |
| Input Current (typical) | 6mA @ 24 VAC/VDC | | |
| Maximum Input Current | 12mA @ 30 VAC/VDC | | |
| ON Voltage Level | > 9.0 VAC/VDC | | |
| OFF Voltage Level | < 2.0 VAC/VDC | | |
| Maximum OFF Current | 1.5 mA | | |
| Status Indicators | Logic Side, Green | | |
| Input Details | | | |
| Input Type | High-Speed DC | | Standard ¹ |
| Location | X0...X9 | | X10...X19 |
| OFF to ON Response | DC | < 2 μ s | 2ms |
| | AC | – | 10ms ² |
| ON to OFF Response | DC | < 2 μ s | 2ms |
| | AC | – | 10ms ² |
| Maximum Switching Frequency | DC | 250kHz | |
| | AC | ~ 30Hz | |

- 1. All inputs may be used as standard inputs. Only the first 10 inputs (X0...X9) are capable of high-speed DC operation.*
- 2. 60Hz to 240Hz filter should be set in the software when using an AC line signal.*

BX-DM1-36ER-D Wiring, Continued

Discrete Input Connection Options

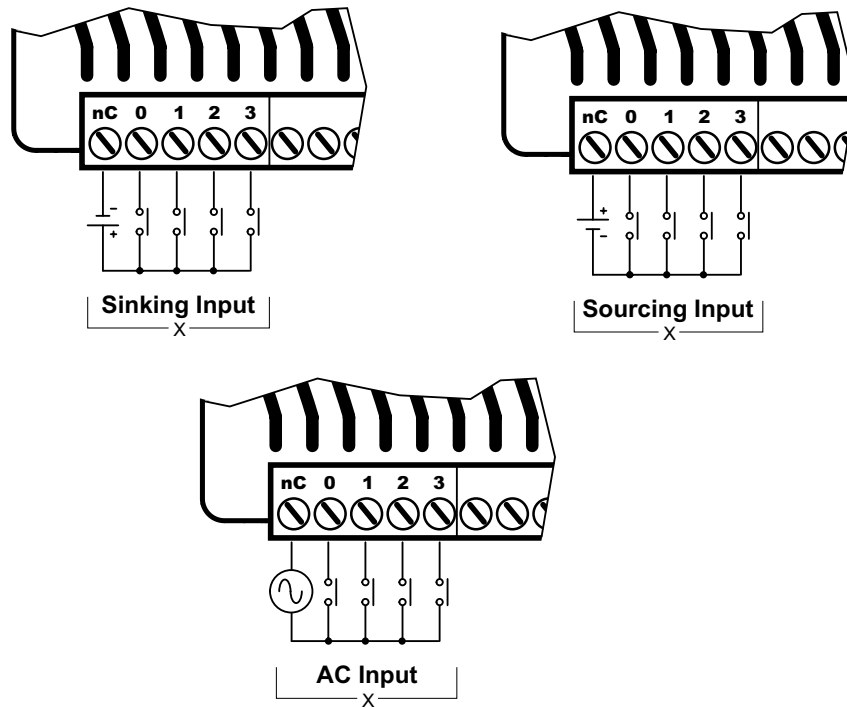

Discrete Input Internal Circuitry *

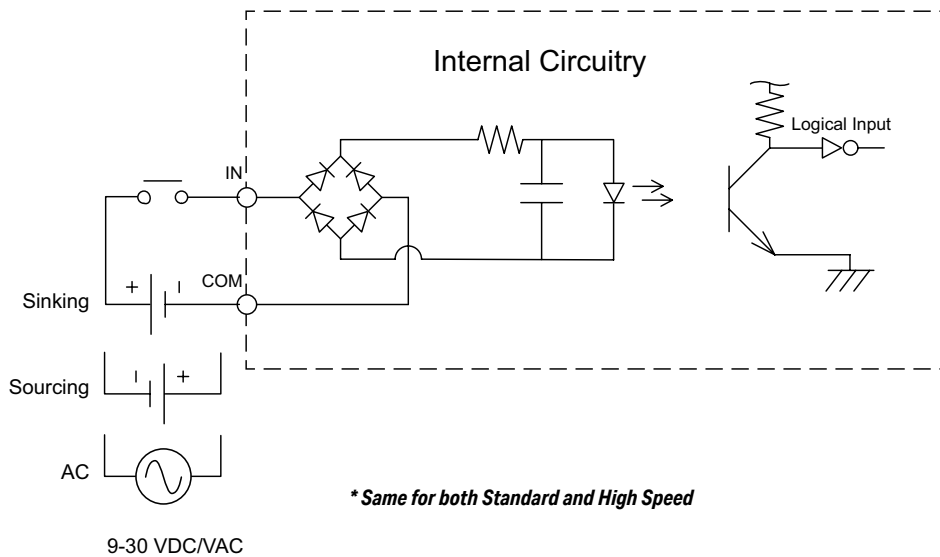

BX-DM1-36ER-D Wiring, Continued

Discrete Output Specifications

| Discrete Output Specifications | |
|--------------------------------|--|
| Output Type | Relay Form A (SPST) |
| Total Outputs per Module | 16 |
| Commons | 4 (4 points/common) Isolated |
| Maximum Current per Common | 8A |
| Nominal Voltage Range | 12–48 VDC 24–240 VAC |
| Operating Voltage Range | 5–60 VDC 5–264 VAC |
| Maximum Voltage | 60VDC 264VAC |
| Minimum Output Current | 0.1 mA @ 24VDC 0.1 mA @ 24VAC |
| Maximum Output Current | 2A |
| Maximum Inrush Current | 5A for 50ms |
| Maximum Leakage Current | 1 μ A (DC), 300 μ A (AC) due to RC snubber circuit |
| ON Voltage Drop | 0.2 V Max |
| Status Indicators | Logic Side, Green |
| Output Details | |
| Output Type | Standard |
| Location | Y0...Y15 |
| ON-OFF Response | <10ms |
| OFF-ON Response | <10ms |
| Maximum Switching Frequency | 10Hz |
| Relay Cycle Life | 5 million operations |
| Mechanical Endurance | 120,000 operations |
| Electrical Endurance | |
| Fuse Type | User-supplied external fuse |

BX-DM1-36ER-D Wiring, Continued

Discrete Output Connection Options

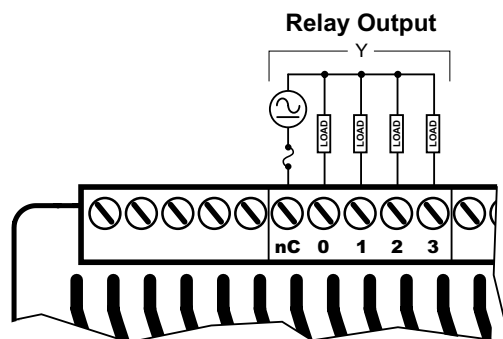

Discrete Standard Output Internal Circuitry

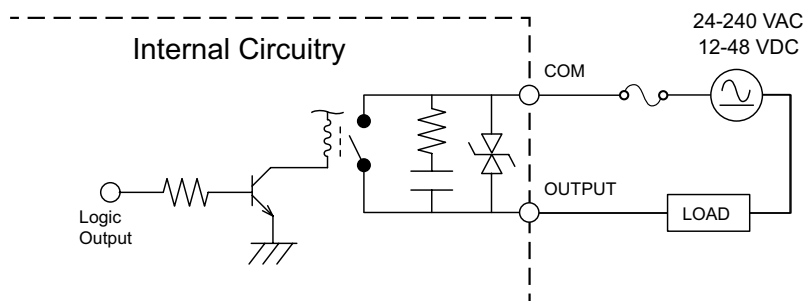

BX-DM1-36AR Wiring

This MPU is made up of 36 discrete I/O points. The connections are grouped as follows:

- 20 discrete inputs - AC rated for 120–240 VAC. They are located along the bottom of the unit; configured in five (5) groups of 5 terminals, each comprised of 4 inputs and an isolated common.
- 16 discrete outputs - Form A Relay (SPST); rated 12–48 VDC/ 24–240 VAC. They are located along the top of the unit starting to the right of the 24VDC auxiliary output terminals. The outputs are configured in four (4) groups of 5 terminals, each comprised of 4 outputs and an isolated common.

This MPU requires an external 120–240 VAC power supply. The AC power supply connection and the 24VDC auxiliary output supply terminals are located on the top left side of the unit.



WARNING: No analog I/O is included on this unit. The 5 terminals to the right of the input and output rails are not used. These terminals are not internally connected. DO NOT CONNECT ANYTHING TO THESE TERMINALS!

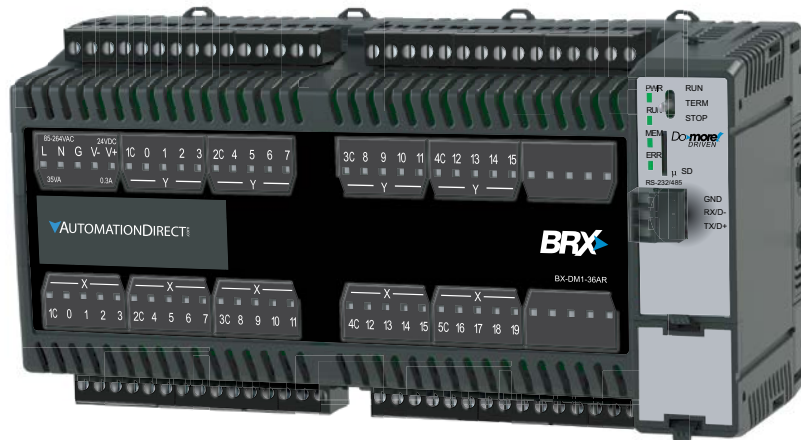

BX-DM1-36AR



NOTE: Four (4) Expansion Modules can be connected to extend I/O capacity.

BX-DM1-36AR Wiring, Continued

Power Supply Specifications

| Power Supply Specifications | |
|-------------------------------------|--|
| Nominal Voltage Range | 120–240 VAC |
| Input Voltage Range (Tolerance) | 85–264 VAC |
| Rated Operating Frequency | 47–63 Hz |
| Maximum Input Power | 40VA |
| Cold Start Inrush Current | 1.5 A, 2ms |
| Maximum Inrush Current (Hot Start) | 1.5 A, 2ms |
| Internal Input Fuse Protection | Micro fuse 250V, 2A Non-replaceable |
| Acceptable External Power Drop Time | 10ms |
| Under Input Voltage Lock-out | 80VAC |
| Input Transient Protection | Input choke and line filter |
| Heat Dissipation | 24.1 W Max |
| Isolated User 24VDC Output | 24VDC @ 0.3 A max, <1V P-P Ripple, Integrated self-resetting short circuit protection |
| Voltage Withstand (dielectric) | 1500VAC Power Inputs to Ground applied for 1 minute 1500VAC Ground to 24VDC Output applied for 1 minute |
| Insulation Resistance | >10MΩ @ 500VDC |
| Software Version Required | Do-more! Designer version 2.0 or later |

Power Supply Connections

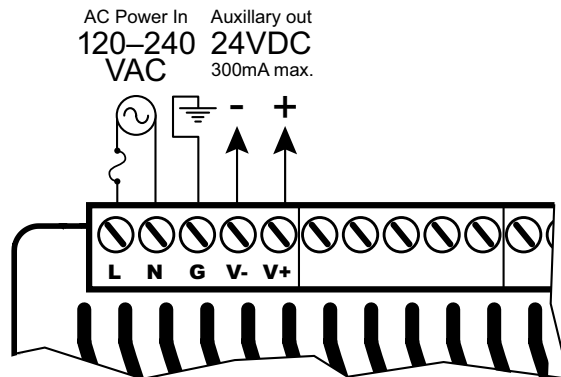

WARNING: Do not exceed the 24VDC auxiliary power supply load limit of 300mA.



WARNING: The BRX System **MUST** have a proper earth ground. Do not operate the BRX MPU without proper earth grounding.

BX-DM1-36AR Wiring, Continued

Discrete Input Specifications

| Discrete Input Specifications | |
|-------------------------------|------------------------------|
| Input Type | AC |
| Total Inputs per Module | 20 |
| Commons | 5 (4 points/common) Isolated |
| Nominal Voltage Range | 120–240 VAC |
| Input Voltage Range | 85–264 VAC |
| Maximum Voltage | 264VAC RMS |
| AC Frequency | 47–63 Hz |
| Input Impedance | 15k Ω |
| Input Current (typical) | 9mA @ 120VAC, 13mA @ 220VAC |
| Maximum Input Current | 14mA @ 120VAC, 20mA @ 220VAC |
| ON Voltage Level | > 85VAC |
| OFF Voltage Level | < 40VAC |
| Maximum OFF Current | 2.5 mA |
| Status Indicators | Logic Side, Green |
| Input Details | |
| Input Type | Standard |
| Location | X0...X19 |
| OFF - ON Response | 10ms |
| ON - OFF Response | 10ms |
| Maximum Switch Frequency | ~ 30Hz |

Discrete Input Connection Options

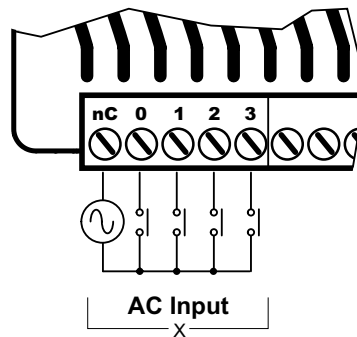

Discrete Input Internal Circuitry

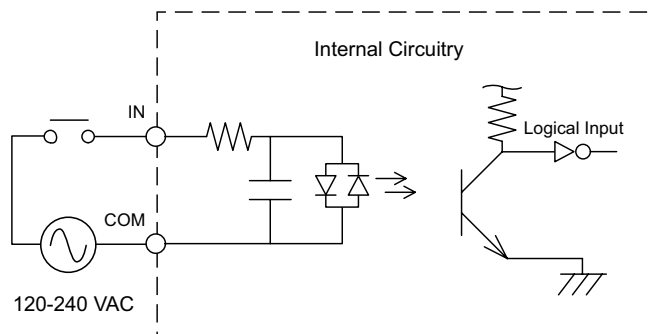

BX-DM1-36AR Wiring, Continued

Discrete Output Specifications

| Discrete Output Specifications | |
|--------------------------------|--|
| Output Type | Relay Form A (SPST) |
| Total Outputs per Module | 16 |
| Commons | 4 (4 points/common) Isolated |
| Maximum Current per Common | 8A |
| Nominal Voltage Range | 12–48 VDC 24–240 VAC |
| Operating Voltage Range | 5–60 VDC 5–264 VAC |
| Maximum Voltage | 60VDC 264VAC |
| Minimum Output Current | 0.1 mA @ 24VDC 0.1 mA @ 24VAC |
| Maximum Output Current | 2A |
| Maximum Inrush Current | 5A for 50ms |
| Maximum Leakage Current | 1 μ A (DC), 300 μ A (AC) due to RC snubber circuit |
| ON Voltage Drop | 0.2 V Max |
| Status Indicators | Logic Side, Green |
| Output Details | |
| Output Type | Standard |
| Location | Y0...Y15 |
| ON-OFF Response | <10ms |
| OFF-ON Response | <10ms |
| Maximum Switching Frequency | 10Hz |
| Relay Cycle Life | 5 million operations |
| Mechanical Endurance | 120,000 operations |
| Electrical Endurance | |
| Fuse Type | User-supplied external fuse |

BX-DM1-36AR Wiring, Continued

Discrete Output Connection Options

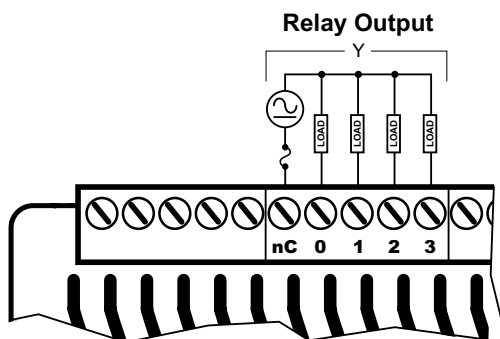

Discrete Standard Output Internal Circuitry

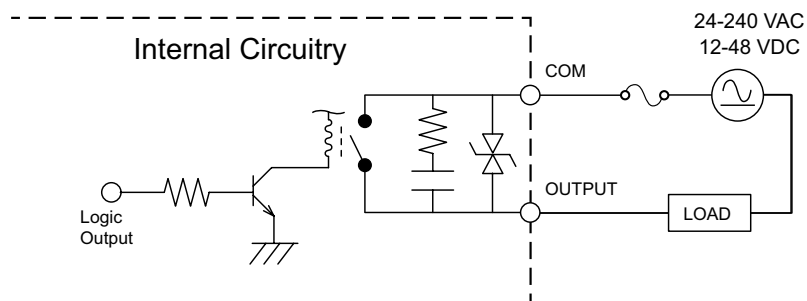

BX 36E Micro PLC Units (MPUs)

BX-DM1E-36ED13 Wiring

This MPU is made up of 36 discrete I/O points. The connections are grouped as follows:

- 20 discrete inputs - sinking/sourcing; rated for 12–24 VAC/VDC. They are located along the bottom of the unit; configured in five (5) groups of 5 terminals, each comprised of 4 inputs and an isolated common.
- 16 discrete outputs - sinking; rated at 12–24 VDC. They are located along the top of the unit starting to the right of the 24VDC auxiliary output terminals. The outputs are configured in four (4) groups of 5 terminals, each comprised of 4 outputs and an isolated common.
- 4 analog inputs and 2 analog outputs. The analog inputs are located along the bottom of the unit to the right of the discrete inputs. The analog inputs are grouped together on 5 terminals consisting of 4 input and a shared analog input common. The analog outputs are located along the top of the unit to the right of the discrete outputs. The analog outputs are grouped together on 5 terminals consisting of 2 outputs and 3 shared analog output common terminals. The analogs share these common features:
 - current or voltage selectable through software
 - 16-bit resolution @ $\pm 20\text{mA}$, $\pm 10\text{VDC}$
 - current signal ranges of 4–20 mA, $\pm 20\text{mA}$
 - voltage signal ranges of 0–5 VDC, 0–10 VDC, $\pm 5\text{VDC}$, $\pm 10\text{VDC}$.

This MPU requires an external 120–240 VAC power supply. The AC power supply connection and the 24VDC auxiliary output supply terminals are located on the top left side of the unit.

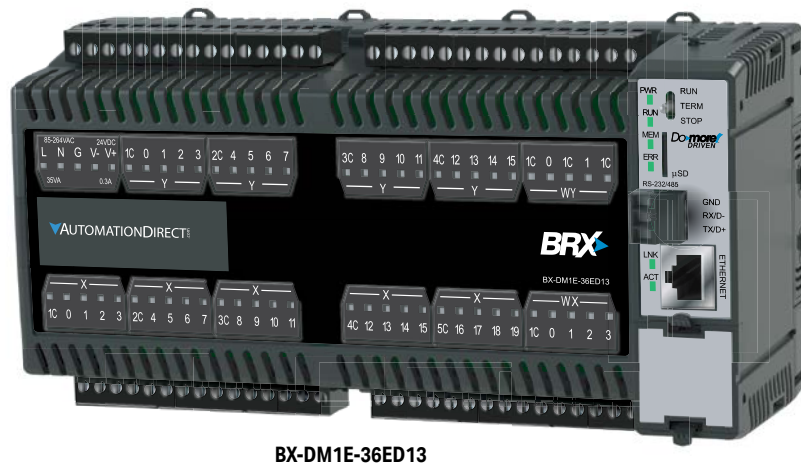

BX-DM1E-36ED13



NOTE: Eight (8) Expansion Modules can be connected to extend I/O capacity.

BX-DM1E-36ED13 Wiring, Continued

Power Supply Specifications

| Power Supply Specifications | |
|-------------------------------------|--|
| Nominal Voltage Range | 120–240 VAC |
| Input Voltage Range (Tolerance) | 85–264 VAC |
| Rated Operating Frequency | 47–63 Hz |
| Maximum Input Power | 40VA |
| Cold Start Inrush Current | 1.5 A, 2ms |
| Maximum Inrush Current (Hot Start) | 1.5 A, 2ms |
| Internal Input Fuse Protection | Micro fuse 250V, 2A Non-replaceable |
| Acceptable External Power Drop Time | 10ms |
| Under Input Voltage Lock-out | 80VAC |
| Input Transient Protection | Input choke and line filter |
| Heat Dissipation | 24.4 W Max |
| Isolated User 24VDC Output | 24VDC @ 0.3 A max, <1V P-P Ripple, Integrated self-resetting short circuit protection |
| Voltage Withstand (dielectric) | 1500VAC Power Inputs to Ground applied for 1 minute 1500VAC Ground to 24VDC Output applied for 1 minute |
| Insulation Resistance | >10M Ω @ 500VDC |
| Software Version Required | Do-more! Designer version 2.0 or later |

Power Supply Connections

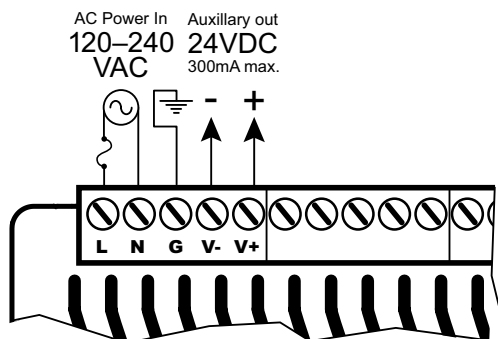

WARNING: Do not exceed the 24VDC auxiliary power supply load limit of 300mA.



WARNING: The BRX System **MUST** have a proper earth ground. Do not operate the BRX MPU without proper earth grounding.

BX-DM1E-36ED13 Wiring, Continued

Discrete Input Specifications

| Discrete Input Specifications | | | |
|-------------------------------|------------------------------|-----------------------|-------------------|
| Input Type | Sink/Source | | |
| Total Inputs per Module | 20 | | |
| Commons | 5 (4 points/common) Isolated | | |
| Nominal Voltage Range | 12–24 VAC/VDC | | |
| Input Voltage Range | 9–30 VAC/VDC | | |
| Maximum Voltage | 30 VAC/VDC | | |
| DC Frequency | 0–250 kHz - High-speed | | |
| Minimum Pulse Width | 0.5 μ s - High-speed | | |
| AC Frequency | 47–63 Hz ² | | |
| Input Impedance | 3k Ω @ 24VDC | | |
| Input Current (typical) | 6mA @ 24 VAC/VDC | | |
| Maximum Input Current | 12mA @ 30 VAC/VDC | | |
| ON Voltage Level | > 9.0 VAC/VDC | | |
| OFF Voltage Level | < 2.0 VAC/VDC | | |
| Maximum OFF Current | 1.5 mA | | |
| Status Indicators | Logic Side, Green | | |
| Input Details | | | |
| Input Type | High-Speed DC | Standard ¹ | |
| Location | X0...X9 | X10...X19 | |
| OFF to ON Response | DC | < 2 μ s | 2ms |
| | AC | – | 10ms ² |
| ON to OFF Response | DC | < 2 μ s | 2ms |
| | AC | – | 10ms ² |
| Maximum Switching Frequency | DC | 250kHz | |
| | AC | ~ 30Hz | |

1. All inputs may be used as standard inputs. Only the first 10 inputs (X0...X9) are capable of high-speed DC operation.

2. 60Hz to 240Hz filter should be set in the software when using an AC line signal.

BX-DM1E-36ED13 Wiring, Continued

Discrete Input Connection Options

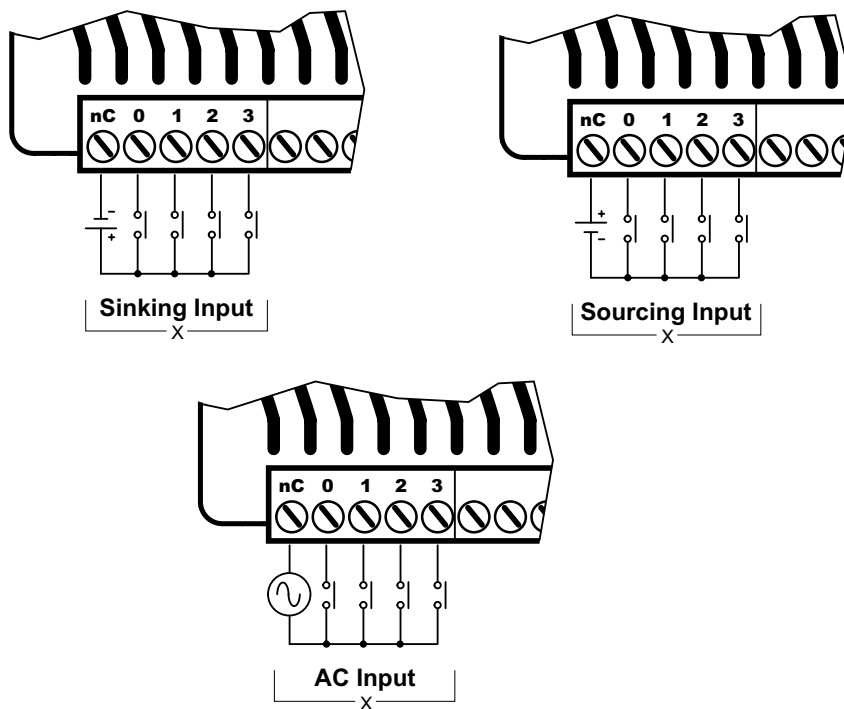

Discrete Input Internal Circuitry *

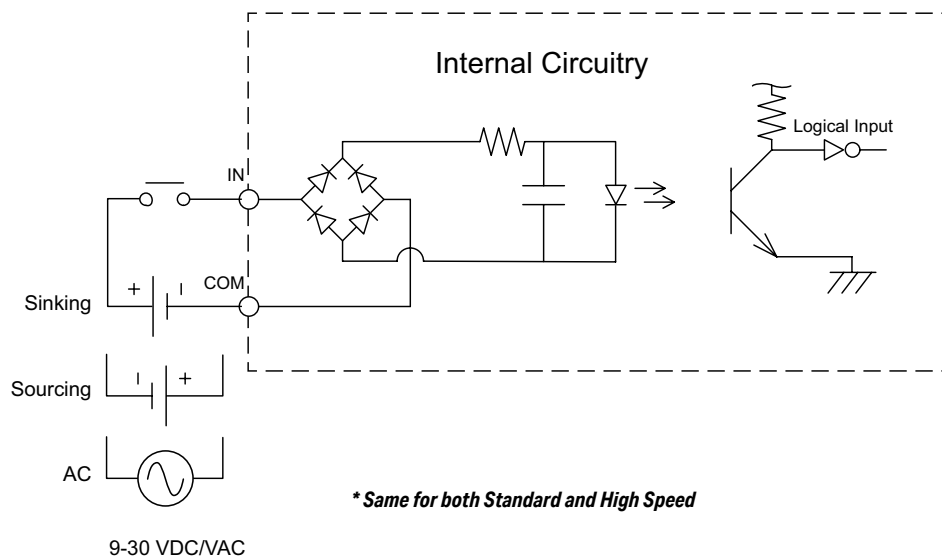

BX-DM1E-36ED13 Wiring, Continued

Discrete Output Specifications

| Discrete Output Specifications | | |
|---|--|-----------------------|
| Output Type | Sinking | |
| Total Outputs per Module | 16 | |
| Commons | 4 (4 points/common) Isolated | |
| Maximum Current per Common | 2A | |
| Nominal Voltage Range | 12–24 VDC | |
| Operating Voltage Range | 5–36 VDC | |
| Maximum Voltage | 36VDC | |
| Minimum Output Current | 0.1 mA @ 24VDC | |
| Maximum Output Current | 0.5 A per output No derating over temperature range | |
| Maximum Inrush Current | 5A for 50ms | |
| Maximum Leakage Current | 10 μ A | |
| ON Voltage Drop | 0.05 VDC | |
| Status Indicators | Logic Side, Green | |
| Output Details | | |
| Output Type | High-Speed | Standard ¹ |
| Location | Y0...Y7 | Y8...Y15 |
| OFF to ON Response | < 2 μ s | < 5ms |
| ON to OFF Response | < 2 μ s | < 2ms |
| Maximum Switching Frequency | 1m cable - 250kHz 10m cable - 100kHz | ~100Hz |
| Overcurrent, Short Circuit Protection and Short to Ground | Current limit by Common Group, self-resetting | N/A |
| Overcurrent Trip Level ² | Between 4A and 8A | N/A |
| Fuse Type | User-supplied external fuse | |

1. All outputs may be used as standard outputs. Only the first 8 outputs (Y0...Y7) are capable of high-speed DC operation.

2. When the high-speed outputs are in an overcurrent situation, the Common terminal Red LED is on. The output LEDs will remain operational even though the output circuitry is turned off and no power is flowing. This condition is not reported to the CPU.

BX-DM1E-36ED13 Wiring, continued

Discrete Output Connection Options

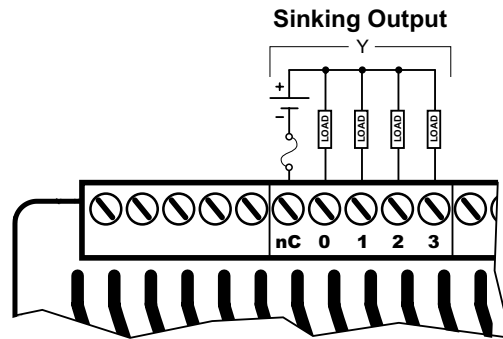

Discrete Standard Output Internal Circuitry

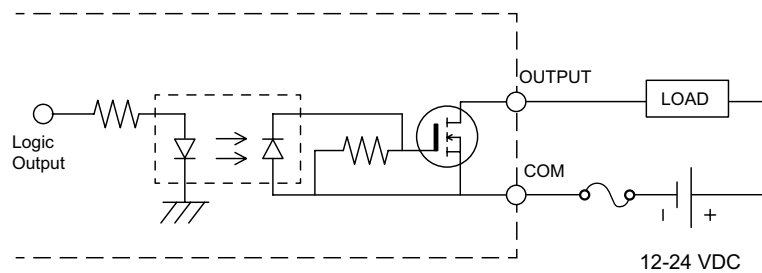

Discrete High-Speed Output Internal Circuitry

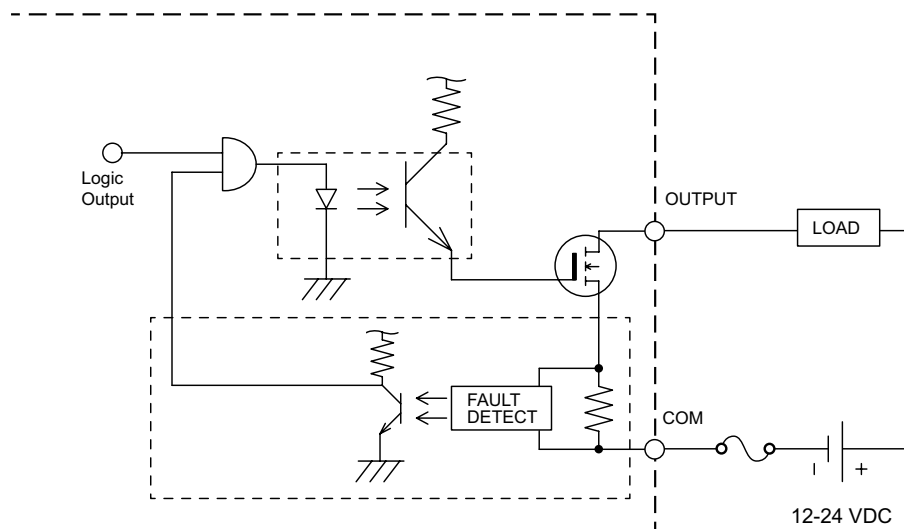

NOTE: When the high speed outputs are in an overcurrent situation, the Common terminal Red LED is on. The output LEDs will remain operational even though the output circuitry is turned off and no power is flowing. This condition is not reported to the CPU.

BX-DM1E-36ED13 Wiring, Continued

Analog Input Specifications

| Analog Input Specifications | |
|--|--|
| Inputs per Module | 4 |
| Commons | 1 |
| Input Voltage Range * | Software Selectable $\pm 10V$, $\pm 5V$, 0–10 V, 0–5 V |
| Input Current Range * | Software Selectable $\pm 20mA$, 4–20 mA |
| Resolution $\pm 10V$, $\pm 20mA$ $\pm 5V$ 0–5 V 4–20 mA 0–10 V | 16 bits (0–65535 counts) 15 bits (0–32767 counts) 14 bits (0–16383 counts) ~15 bits (6553–32767 counts) 15 bits (0–32767 counts) |
| Input Impedance Voltage Modes | 100k Ω |
| Absolute Maximum Input, Voltage Mode | $\pm 30V$ |
| Input Impedance Current Modes | 249 Ω |
| Absolute Maximum Input, Current Mode | $\pm 40mA$ sustained, $\pm 100mA$ for < 5s |
| Conversion Time | 1.2 ms |
| Input Stability | 0.02% of Full Hardware Range = 13 Counts |
| Full Scale Calibration Error | 0.05% of Full Hardware Range = 33 Counts |
| Offset Calibration Error | 0.01% of Full Hardware Range = 7 Counts |
| Accuracy vs Temperature Error | 0.05% of Full Hardware Range = 33 Counts |
| Maximum Linearity Error (End to End) | 0.1% of Full Hardware Range = 66 Counts |
| Maximum Inaccuracy | 0.2% of Full Hardware Range = 131 Counts |
| Fuse Type | User-supplied external fuse |

* *Software selectable per channel*

BX-DM1E-36ED13 Wiring, Continued

Analog Input Connection Options

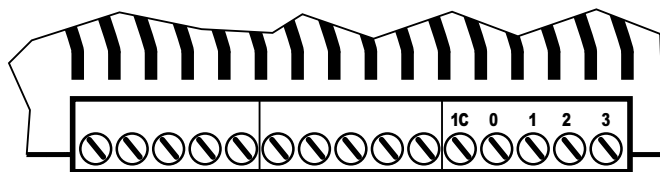

Analog Voltage Input Circuits

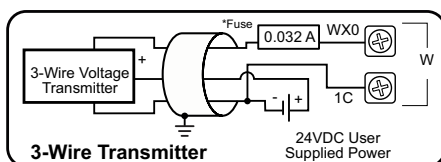
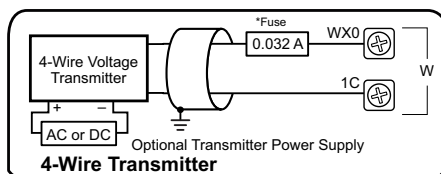

NOTE: Shield should be connected only at one end, to ground at the source device.

Analog Current Sinking Input Circuits

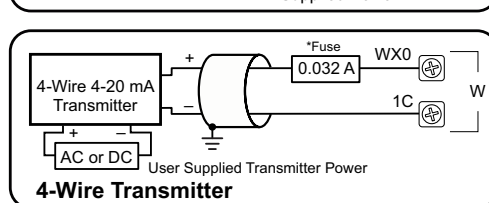
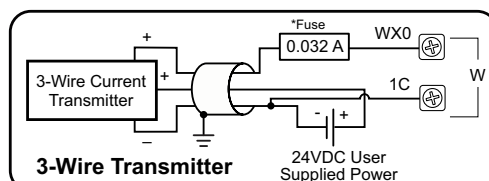
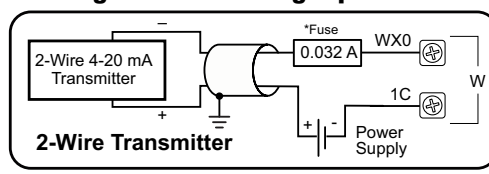

NOTE: Shield should be connected only at one end, to ground at the source device.



NOTE: An Edison S500-32-R 0.032A fast-acting fuse is recommended for all analog voltage inputs, analog outputs, and current loops.

BX-DM1E-36ED13 Wiring, Continued

Analog Output Specifications

| Analog Output Specifications | |
|--|--|
| Outputs per Module | 2 |
| Commons | 3 |
| Output Voltage Range * | Software Selectable $\pm 10V$, $\pm 5V$, $0-10 V$, $0-5 V$ |
| Output Current Range * | Software Selectable $\pm 20mA$, $4-20 mA$ |
| Resolution $\pm 10V$, $\pm 20mA$ $\pm 5V$ $0-5 V$ $4-20 mA$ $0-10 V$ | 16 bits (0–65535 counts) 15 bits (0–32767 counts) 14 bits (0–16383 counts) ~15 bits (6553–32767 counts) 15 bits (0–32767 counts) |
| Minimum Voltage Load Impedance | 1k Ω |
| Maximum Current Load Impedance | 500 Ω |
| Maximum Rating | Continuous Short Circuit Protected |
| Settling Time | < 1ms |
| Output Stability | 0.02% of Full Hardware Range = 13 Counts |
| Full Scale Calibration Error | 0.05% of Full Hardware Range = 33 Counts |
| Offset Calibration Error | 0.01% of Full Hardware Range = 7 Counts |
| Accuracy vs Temperature Error | 0.05% of Full Hardware Range = 33 Counts |
| Maximum Linearity Error (End to End) | 0.1% of Full Hardware Range = 66 Counts |
| Maximum Inaccuracy | 0.2% of Full Hardware Range = 131 Counts |
| Fuse Type | User-supplied external fuse |

* Software selectable per channel

Analog Output Connection Options

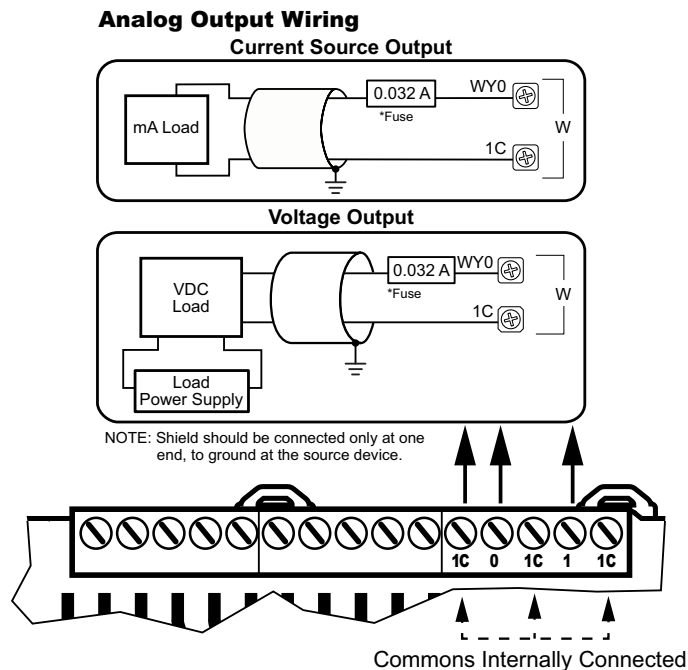

NOTE: An Edison S500-32-R 0.032A fast-acting fuse is recommended for all analog voltage inputs, analog outputs, and current loops.

BX-DM1E-36ED13-D Wiring

This MPU is made up of 36 discrete I/O points. The connections are grouped as follows:

- 20 discrete inputs - sinking/sourcing; rated for 12–24 VAC/VDC. They are located along the bottom of the unit; configured in five (5) groups of 5 terminals, each comprised of 4 inputs and an isolated common.
- 16 discrete outputs - sinking; rated at 12–24 VDC. They are located along the top of the unit starting to the right of the 24VDC external power supply terminals. The outputs are configured in four (4) groups of five (5) terminals, each comprised of four (4) outputs and an isolated common.
- 4 analog inputs and 2 analog outputs. The analog inputs are located along the bottom of the unit to the right of the discrete inputs. The analog inputs are grouped together on 5 terminals consisting of 4 input and a shared analog input common. The analog outputs are located along the top of the unit to the right of the discrete outputs. The analog outputs are grouped together on 5 terminals consisting of 2 outputs and 3 shared analog output common terminals. The analogs share these common features:
 - current or voltage selectable through software,
 - 16-bit resolution @ ± 20 mA, ± 10 VDC
 - current signal ranges of 4–20 mA, ± 20 mA,
 - voltage signal ranges of 0–5 VDC, 0–10 VDC, ± 5 VDC, ± 10 VDC.

This MPU requires an external 12–24 VDC power supply. The DC power supply connection is located on the top left side of the unit. There is no 24VDC auxiliary output supply.

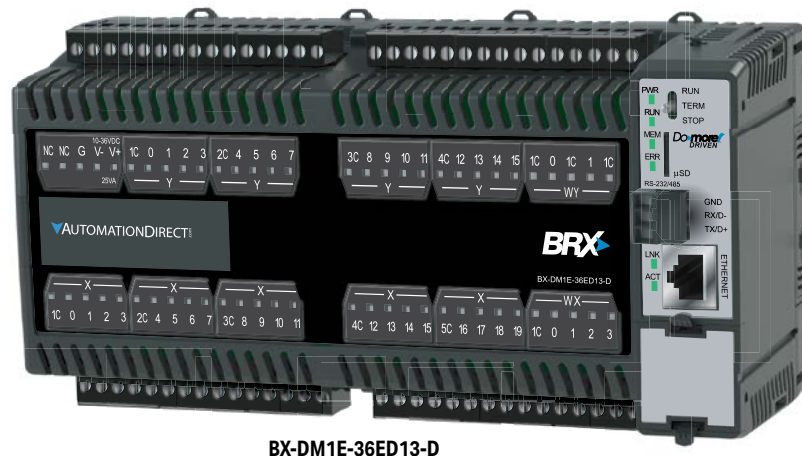

BX-DM1E-36ED13-D



NOTE: Eight (8) Expansion Modules can be connected to extend I/O capacity.

BX-DM1E-36ED13-D Wiring, Continued

Power Supply Specifications

| Power Supply Specifications | |
|-------------------------------------|---|
| Nominal Voltage Range* | 12–24 VDC |
| Input Voltage Range (Tolerance)* | 10–36 VDC |
| Maximum Input Voltage Ripple | < ±10% |
| Maximum Input Power | 30W |
| Cold Start Inrush Current | 5A, 2ms |
| Maximum Inrush Current (Hot Start) | 5A, 2ms |
| Internal Input Protection | Reverse polarity protection and undervoltage lockout via transistor circuit |
| Acceptable External Power Drop Time | 10ms |
| Under Input Voltage Lock-out | <9VDC |
| Heat Dissipation | 22.1 W Max |
| Isolated User 24VDC Output | None |
| Voltage Withstand (dielectric) | 1500VAC power Inputs to ground applied for 1 minute |
| Insulation Resistance | >10MΩ @ 500VDC |
| Software Version Required | Do-more! Designer version 2.0 or later |

* Class 2 or LPS Power Supply required.

Power Supply Connections

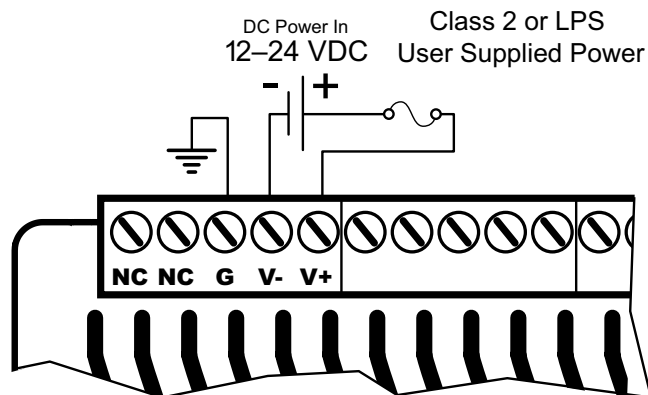

WARNING: No External AC power supply needed on this unit. The two terminals marked "NC" are not used. These terminals are not internally connected. **DO NOT CONNECT ANYTHING TO THESE TERMINALS!**



WARNING: The BRX System **MUST** have a proper earth ground. Do not operate the BRX MPU without proper earth grounding.

BX-DM1E-36ED13-D Wiring, Continued

Discrete Input Specifications

| Discrete Input Specifications | | | |
|-------------------------------|------------------------------|-----------------------|-------------------|
| Input Type | Sink/Source | | |
| Total Inputs per Module | 20 | | |
| Commons | 5 (4 points/common) Isolated | | |
| Nominal Voltage Range | 12–24 VAC/VDC | | |
| Input Voltage Range | 9–30 VAC/VDC | | |
| Maximum Voltage | 30 VAC/VDC | | |
| DC Frequency | 0–250 kHz - High-speed | | |
| Minimum Pulse Width | 0.5 μ s - High-speed | | |
| AC Frequency | 47–63 Hz ² | | |
| Input Impedance | 3k Ω @ 24VDC | | |
| Input Current (typical) | 6mA @ 24 VAC/VDC | | |
| Maximum Input Current | 12mA @ 30 VAC/VDC | | |
| ON Voltage Level | > 9.0 VAC/VDC | | |
| OFF Voltage Level | < 2.0 VAC/VDC | | |
| Maximum OFF Current | 1.5 mA | | |
| Status Indicators | Logic Side, Green | | |
| Input Details | | | |
| Input Type | High-Speed DC | Standard ¹ | |
| Location | X0...X9 | X10...X19 | |
| OFF to ON Response | DC | < 2 μ s | 2ms |
| | AC | – | 10ms ² |
| ON to OFF Response | DC | < 2 μ s | 2ms |
| | AC | – | 10ms ² |
| Maximum Switching Frequency | DC | 250kHz | |
| | AC | ~ 30Hz | |

- 1. All inputs may be used as standard inputs. Only the first 10 inputs (X0...X9) are capable of high-speed DC operation.*
- 2. 60Hz to 240Hz filter should be set in the software when using an AC line signal.*

BX-DM1E-36ED13-D Wiring, Continued

Discrete Input Connection Options

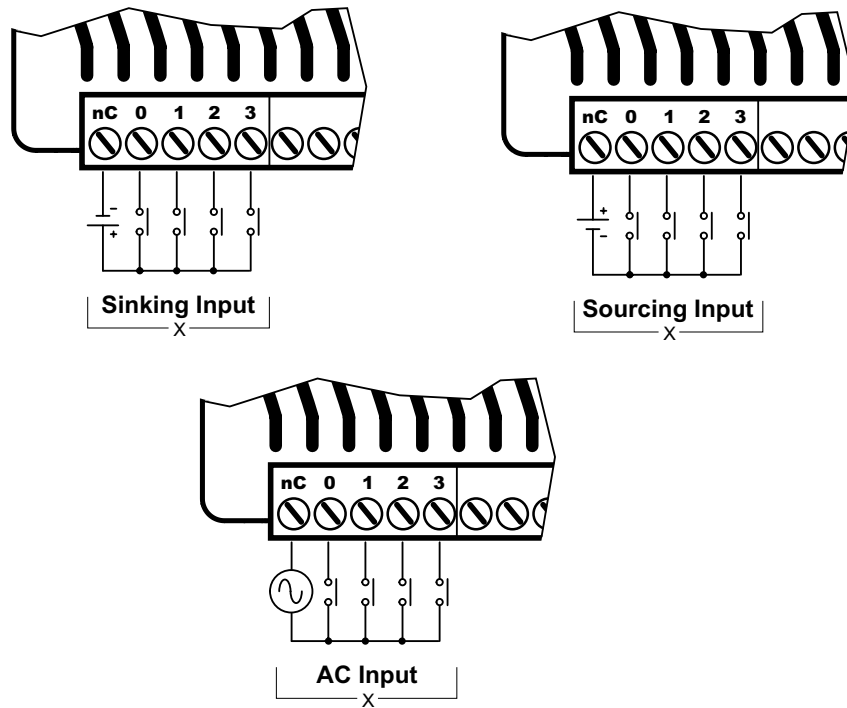

Discrete Input Internal Circuitry *

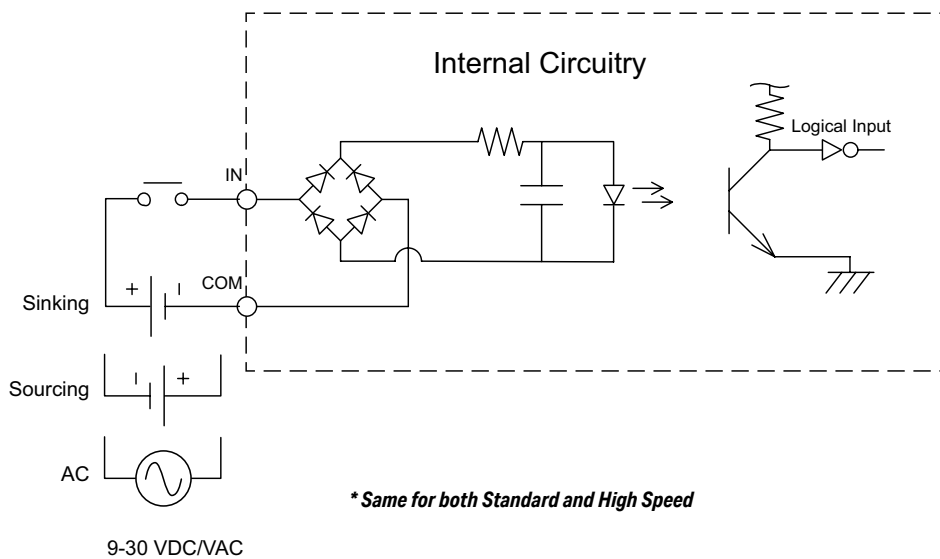

BX-DM1E-36ED13-D Wiring, Continued

Discrete Output Specifications

| Discrete Output Specifications | | |
|---|--|-----------------------|
| Output Type | Sinking | |
| Total Outputs per Module | 16 | |
| Commons | 4 (4 points/common) Isolated | |
| Maximum Current per Common | 2A | |
| Nominal Voltage Range | 12–24 VDC | |
| Operating Voltage Range | 5–36 VDC | |
| Maximum Voltage | 36VDC | |
| Minimum Output Current | 0.1 mA @ 24VDC | |
| Maximum Output Current | 0.5 A per output No derating over temperature range | |
| Maximum Inrush Current | 5A for 50ms | |
| Maximum Leakage Current | 10 μ A | |
| ON Voltage Drop | 0.05 VDC | |
| Status Indicators | Logic Side, Green | |
| Output Details | | |
| Output Type | High-Speed | Standard ¹ |
| Location | Y0...Y7 | Y8...Y15 |
| OFF to ON Response | < 2 μ s | < 5ms |
| ON to OFF Response | < 2 μ s | < 2ms |
| Maximum Switching Frequency | 1m cable - 250kHz 10m cable - 100kHz | ~100Hz |
| Overcurrent, Short Circuit Protection and Short to Ground | Current limit by Common Group, self-resetting | N/A |
| Overcurrent Trip Level ² | Between 4A and 8A | N/A |
| Fuse Type | User-supplied external fuse | |

- 1. All outputs may be used as standard outputs. Only the first 8 outputs (Y0...Y7) are capable of high-speed DC operation.*
- 2. When the high-speed outputs are in an overcurrent situation, the Common terminal Red LED is on. The output LEDs will remain operational even though the output circuitry is turned off and no power is flowing. This condition is not reported to the CPU.*

BX-DM1E-36ED13-D Wiring, Continued

Discrete Output Connection Options

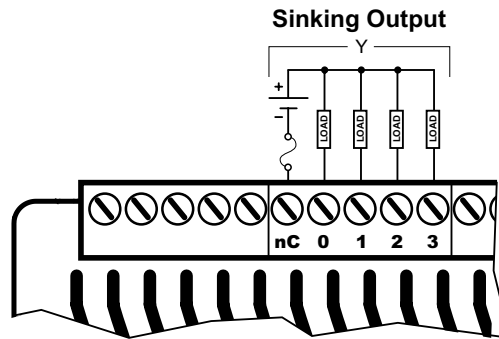

Discrete Standard Output Internal Circuitry

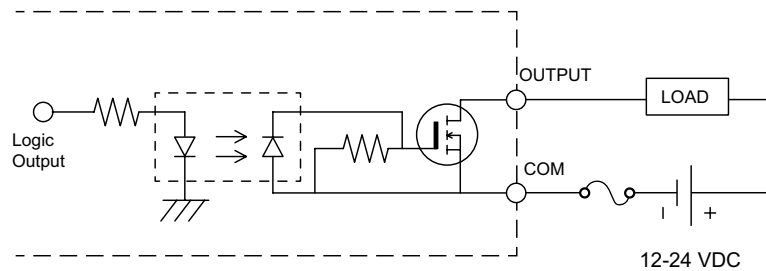

Discrete High-Speed Output Internal Circuitry

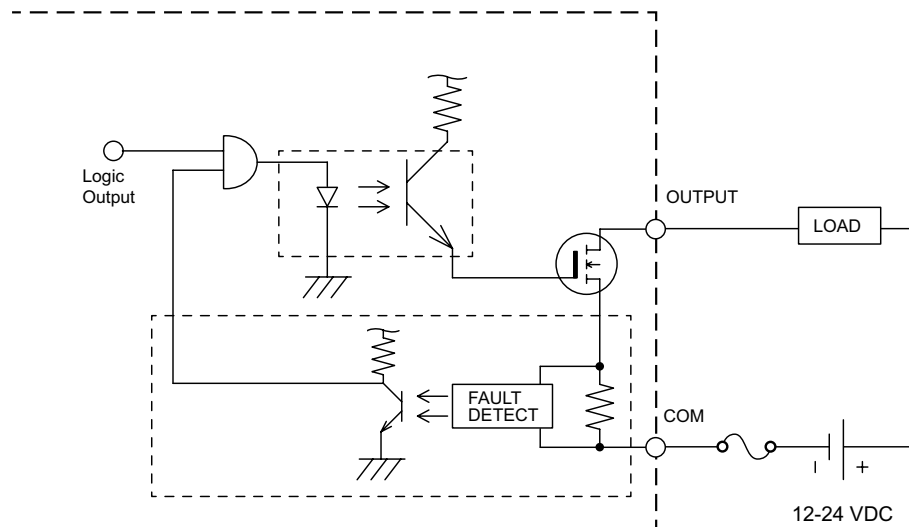

NOTE: When the high speed outputs are in an overcurrent situation, the Common terminal Red LED is on. The output LEDs will remain operational even though the output circuitry is turned off and no power is flowing. This condition is not reported to the CPU.

BX-DM1E-36ED13-D Wiring, Continued

Analog Input Specifications

| Analog Input Specifications | |
|--|--|
| Inputs per Module | 4 |
| Commons | 1 |
| Input Voltage Range * | Software Selectable $\pm 10V$, $\pm 5V$, 0–10 V, 0–5 V |
| Input Current Range * | Software Selectable $\pm 20mA$, 4–20 mA |
| Resolution $\pm 10V$, $\pm 20mA$ $\pm 5V$ 0–5 V 4–20 mA 0–10 V | 16 bits (0–65535 counts) 15 bits (0–32767 counts) 14 bits (0–16383 counts) ~15 bits (6553–32767 counts) 15 bits (0–32767 counts) |
| Input Impedance Voltage Modes | 100k Ω |
| Absolute Maximum Input, Voltage Mode | $\pm 30V$ |
| Input Impedance Current Modes | 249 Ω |
| Absolute Maximum Input, Current Mode | $\pm 40mA$ sustained, $\pm 100mA$ for < 5s |
| Conversion Time | 1.2 ms |
| Input Stability | 0.02% of Full Hardware Range = 13 Counts |
| Full Scale Calibration Error | 0.05% of Full Hardware Range = 33 Counts |
| Offset Calibration Error | 0.01% of Full Hardware Range = 7 Counts |
| Accuracy vs Temperature Error | 0.05% of Full Hardware Range = 33 Counts |
| Maximum Linearity Error (End to End) | 0.1% of Full Hardware Range = 66 Counts |
| Maximum Inaccuracy | 0.2% of Full Hardware Range = 131 Counts |
| Fuse Type | User-supplied external fuse |

* Software selectable per channel

BX-DM1E-36ED13-D Wiring, Continued

Analog Input Connection Options

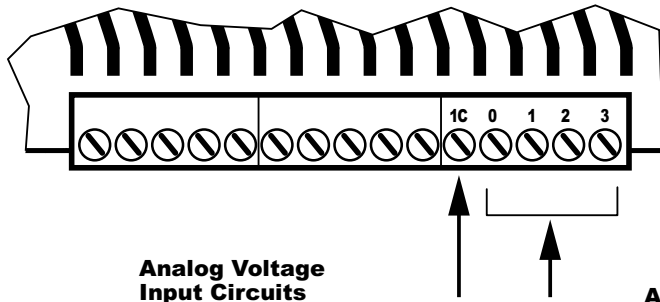

Analog Voltage Input Circuits

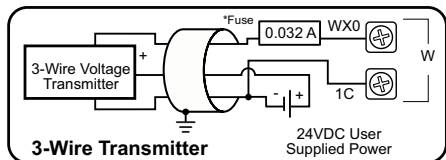
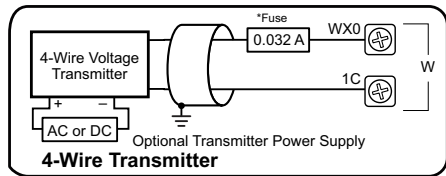

NOTE: Shield should be connected only at one end, to ground at the source device.

Analog Current Sinking Input Circuits

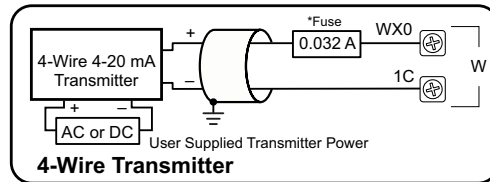
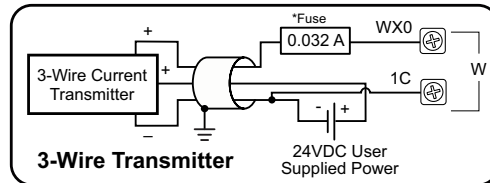
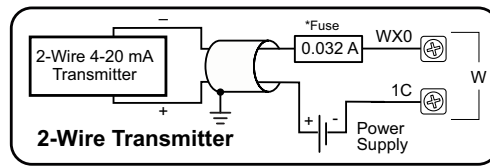

NOTE: Shield should be connected only at one end, to ground at the source device.



NOTE: An Edison S500-32-R 0.032A fast-acting fuse is recommended for all analog voltage inputs, analog outputs, and current loops.

BX-DM1E-36ED13-D Wiring, Continued

Analog Output Specifications

| Analog Output Specifications | |
|--|--|
| Outputs per Module | 2 |
| Commons | 3 |
| Output Voltage Range * | Software Selectable $\pm 10V$, $\pm 5V$, 0–10 V, 0–5 V |
| Output Current Range * | Software Selectable $\pm 20mA$, 4–20 mA |
| Resolution $\pm 10V$, $\pm 20mA$ $\pm 5V$ 0–5 V 4–20 mA 0–10 V | 16 bits (0–65535 counts) 15 bits (0–32767 counts) 14 bits (0–16383 counts) ~15 bits (6553–32767 counts) 15 bits (0–32767 counts) |
| Minimum Voltage Load Impedance | 1k Ω |
| Maximum Current Load Impedance | 500 Ω |
| Maximum Rating | Continuous Short Circuit Protected |
| Settling Time | < 1ms |
| Output Stability | 0.02% of Full Hardware Range = 13 Counts |
| Full Scale Calibration Error | 0.05% of Full Hardware Range = 33 Counts |
| Offset Calibration Error | 0.01% of Full Hardware Range = 7 Counts |
| Accuracy vs Temperature Error | 0.05% of Full Hardware Range = 33 Counts |
| Maximum Linearity Error (End to End) | 0.1% of Full Hardware Range = 66 Counts |
| Maximum Inaccuracy | 0.2% of Full Hardware Range = 131 Counts |
| Fuse Type | User-supplied external fuse |

* Software selectable per channel

Analog Output Connection Options

Analog Output Wiring

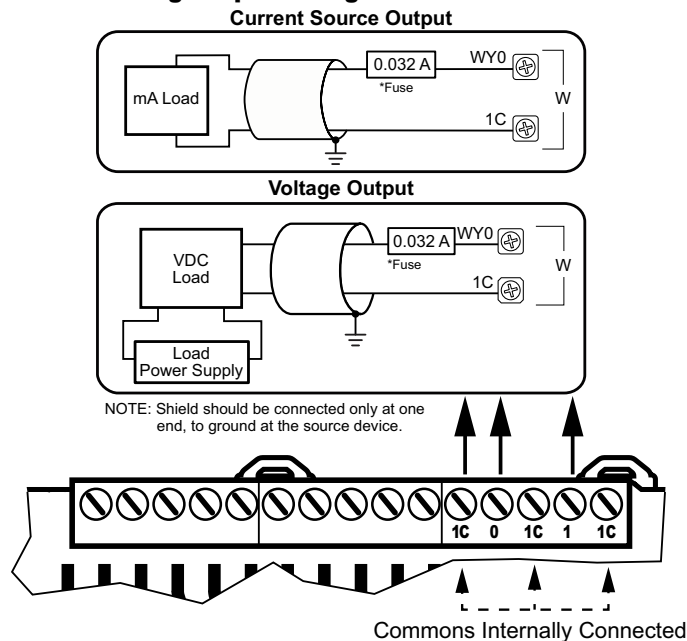

NOTE: An Edison S500-32-R 0.032A fast-acting fuse is recommended for all analog voltage inputs, analog outputs, and current loops.

BX-DM1E-36ED23 Wiring

This MPU is made up of 36 discrete I/O points. The connections are grouped as follows:

- 20 discrete inputs - sinking/sourcing; rated for 12–24 VAC/VDC. They are located along the bottom of the unit; configured in five (5) groups of 5 terminals, each comprised of 4 inputs and an isolated common.
- 16 discrete outputs - sourcing; rated at 12–24 VDC. They are located along the top of the unit starting to the right of the 24VDC auxiliary output terminals. The outputs are configured in four (4) groups of 5 terminals, each comprised of 4 outputs and an isolated common.
- 4 analog inputs and 2 analog outputs. The analog inputs are located along the bottom of the unit to the right of the discrete inputs. The analog inputs are grouped together on 5 terminals consisting of 4 input and a shared analog input common. The analog outputs are located along the top of the unit to the right of the discrete outputs. The analog outputs are grouped together on 5 terminals consisting of 2 outputs and 3 shared analog output common terminals. The analogs share these common features:
 - current or voltage selectable through software,
 - 16-bit resolution @ $\pm 20\text{mA}$, $\pm 10\text{VDC}$
 - current signal ranges of 4–20 mA, $\pm 20\text{mA}$,
 - voltage signal ranges of 0–5 VDC, 0–10 VDC, $\pm 5\text{VDC}$, $\pm 10\text{VDC}$.

This MPU requires an external 120–240 VAC power supply. The AC power supply connection and the 24VDC auxiliary output supply terminals are located on the top left side of the unit.

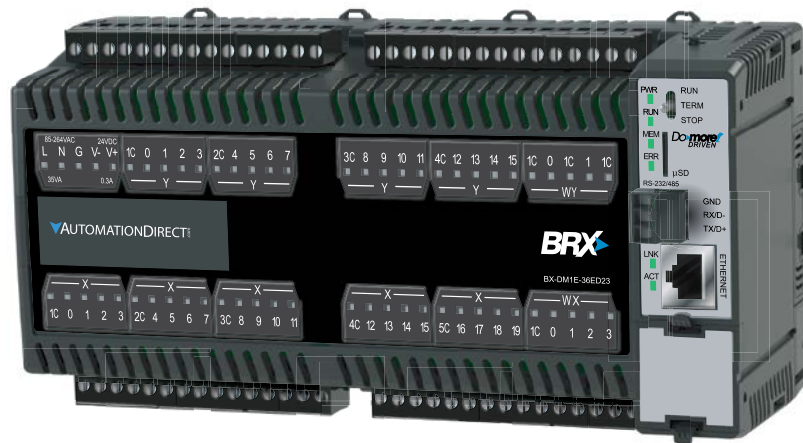

BX-DM1E-36ED23



NOTE: Eight (8) Expansion Modules can be connected to extend I/O capacity.

BX-DM1E-36ED23 Wiring, Continued

Power Supply Specifications

| Power Supply Specifications | |
|-------------------------------------|--|
| Nominal Voltage Range | 120–240 VAC |
| Input Voltage Range (Tolerance) | 85–264 VAC |
| Rated Operating Frequency | 47–63 Hz |
| Maximum Input Power | 40VA |
| Cold Start Inrush Current | 1.5 A, 2ms |
| Maximum Inrush Current (Hot Start) | 1.5 A, 2ms |
| Internal Input Fuse Protection | Micro fuse 250V, 2A Non-replaceable |
| Acceptable External Power Drop Time | 10ms |
| Under Input Voltage Lock-out | 80VAC |
| Input Transient Protection | Input choke and line filter |
| Heat Dissipation | 24.4 W Max |
| Isolated User 24VDC Output | 24VDC @ 0.3 A max, <1V P-P Ripple, Integrated self-resetting short circuit protection |
| Voltage Withstand (dielectric) | 1500VAC Power Inputs to Ground applied for 1 minute 1500VAC Ground to 24VDC Output applied for 1 minute |
| Insulation Resistance | >10MΩ @ 500VDC |
| Software Version Required | Do-more! Designer version 2.0 or later |

Power Supply Connections

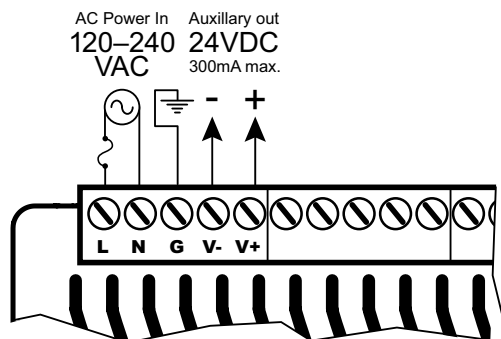

WARNING: Do not exceed the 24VDC auxiliary power supply load limit of 300mA.



WARNING: The BRX System **MUST** have a proper earth ground. Do not operate the BRX MPU without proper earth grounding.

BX-DM1E-36ED23 Wiring, Continued

Discrete Input Specifications

| Discrete Input Specifications | | | |
|-------------------------------|------------------------------|-------------|-----------------------|
| Input Type | Sink/Source | | |
| Total Inputs per Module | 20 | | |
| Commons | 5 (4 points/common) Isolated | | |
| Nominal Voltage Range | 12–24 VAC/VDC | | |
| Input Voltage Range | 9–30 VAC/VDC | | |
| Maximum Voltage | 30 VAC/VDC | | |
| DC Frequency | 0–250 kHz - High-speed | | |
| Minimum Pulse Width | 0.5 μ s - High-speed | | |
| AC Frequency | 47–63 Hz ² | | |
| Input Impedance | 3k Ω @ 24VDC | | |
| Input Current (typical) | 6mA @ 24 VAC/VDC | | |
| Maximum Input Current | 12mA @ 30 VAC/VDC | | |
| ON Voltage Level | > 9.0 VAC/VDC | | |
| OFF Voltage Level | < 2.0 VAC/VDC | | |
| Maximum OFF Current | 1.5 mA | | |
| Status Indicators | Logic Side, Green | | |
| Input Details | | | |
| Input Type | High-Speed DC | | Standard ¹ |
| Location | X0...X9 | | X10...X19 |
| OFF to ON Response | DC | < 2 μ s | 2ms |
| | AC | – | 10ms ² |
| ON to OFF Response | DC | < 2 μ s | 2ms |
| | AC | – | 10ms ² |
| Maximum Switching Frequency | DC | 250kHz | |
| | AC | ~ 30Hz | |

- 1. All inputs may be used as standard inputs. Only the first 10 inputs (X0...X9) are capable of high-speed DC operation.*
- 2. 60Hz to 240Hz filter should be set in the software when using an AC line signal.*

BX-DM1E-36ED23 Wiring, Continued

Discrete Input Connection Options

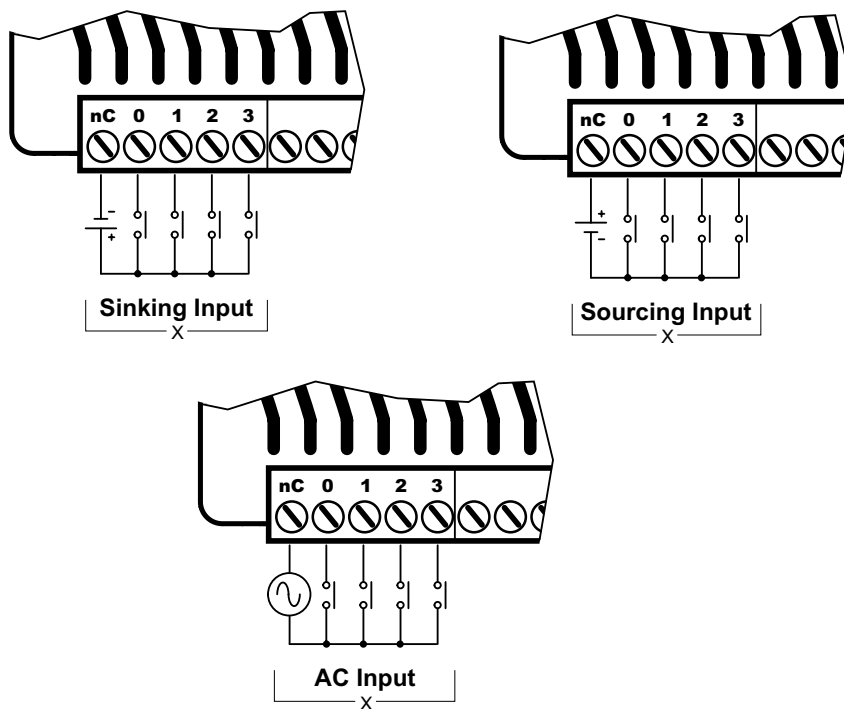

Discrete Input Internal Circuitry *

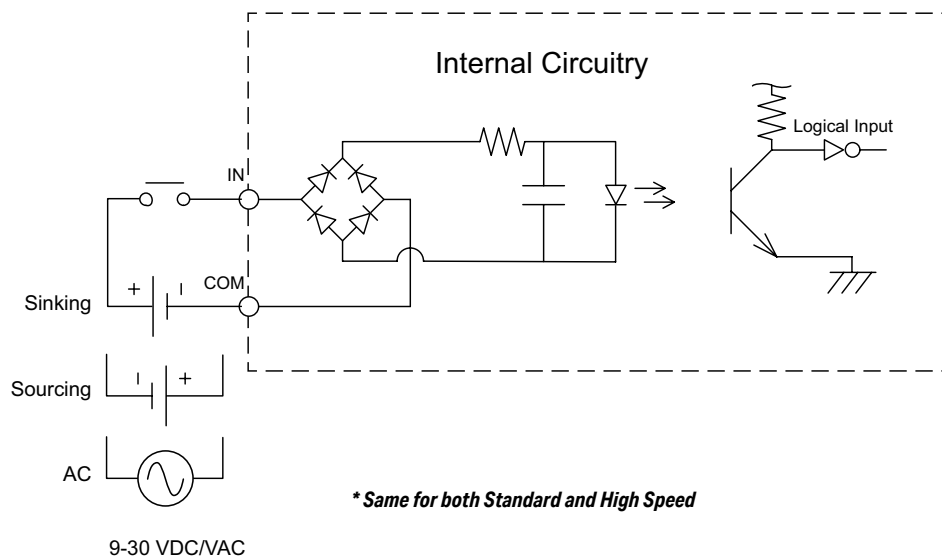

BX-DM1E-36ED23 Wiring, Continued

Discrete Output Specifications

| Discrete Output Specifications | | |
|---|--|-----------------------|
| Output Type | Sourcing | |
| Total Outputs per Module | 16 | |
| Commons | 4 (4 points/common) Isolated | |
| Maximum Current per Common | 2A | |
| Nominal Voltage Range | 12–24 VDC | |
| Operating Voltage Range | 5–36 VDC | |
| Maximum Voltage | 36VDC | |
| Minimum Output Current | 0.1 mA @ 24VDC | |
| Maximum Output Current | 0.5 A per output No derating over temperature range | |
| Maximum Inrush Current | 5A for 50ms | |
| Maximum Leakage Current | 10 μ A | |
| ON Voltage Drop | 0.05 VDC | |
| Status Indicators | Logic Side, Green | |
| Output Details | | |
| Output Type | High-Speed | Standard ¹ |
| Location | Y0...Y7 | Y8...Y15 |
| OFF to ON Response | < 2 μ s | < 5ms |
| ON to OFF Response | < 2 μ s | < 2ms |
| Maximum Switching Frequency | 1m cable - 250kHz 10m cable - 100kHz | ~100Hz |
| Overcurrent, Short Circuit Protection and Short to Ground | Current limit by Common Group, self-resetting | N/A |
| Overcurrent Trip Level ² | Between 4A and 8A | N/A |
| Fuse Type | User-supplied external fuse | |

- 1. All outputs may be used as standard outputs. Only the first 8 outputs (Y0...Y7) are capable of high-speed DC operation.*
- 2. When the high-speed outputs are in an overcurrent situation, the Common terminal Red LED is on. The output LEDs will remain operational even though the output circuitry is turned off and no power is flowing. This condition is not reported to the CPU.*

BX-DM1E-36ED23 Wiring, Continued

Discrete Output Connection Options

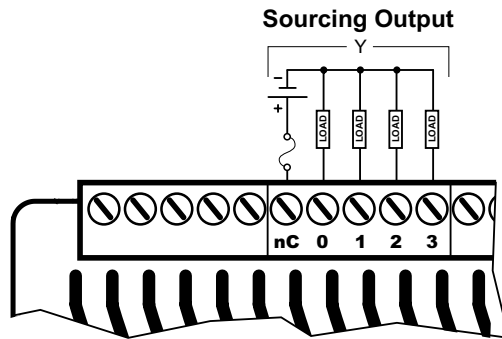

Discrete Standard Output Internal Circuitry

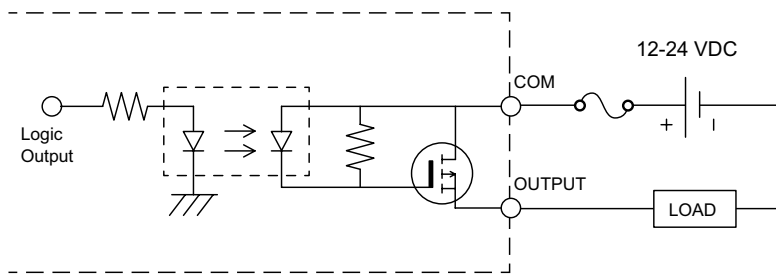

Discrete High-Speed Output Internal Circuitry

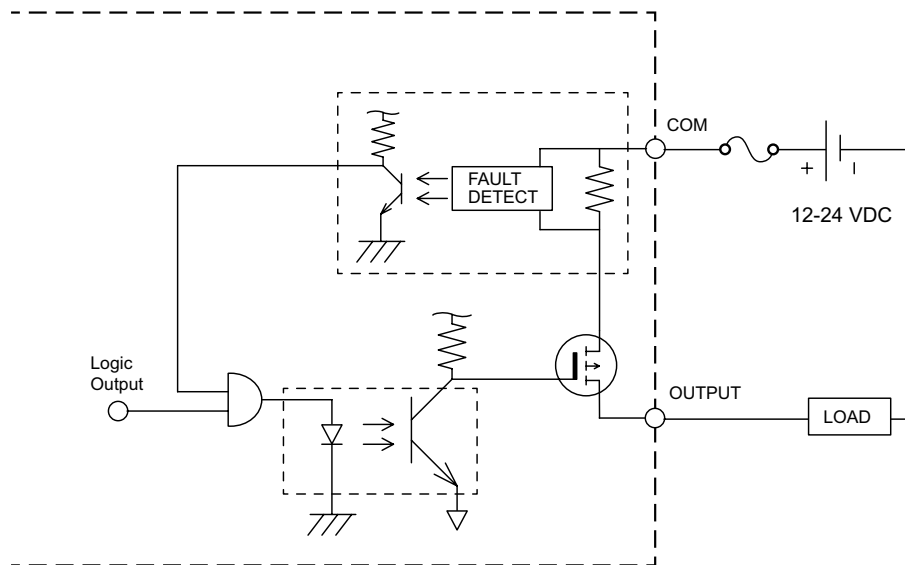

NOTE: When the high speed outputs are in an overcurrent situation, the Common terminal Red LED is on. The output LEDs will remain operational even though the output circuitry is turned off and no power is flowing. This condition is not reported to the CPU.

BX-DM1E-36ED23 Wiring, Continued

Analog Input Specifications

| Analog Input Specifications | |
|--|--|
| Inputs per Module | 4 |
| Commons | 1 |
| Input Voltage Range * | Software Selectable $\pm 10V$, $\pm 5V$, 0–10 V, 0–5 V |
| Input Current Range * | Software Selectable $\pm 20mA$, 4–20 mA |
| Resolution $\pm 10V$, $\pm 20mA$ $\pm 5V$ 0–5 V 4–20 mA 0–10 V | 16 bits (0–65535 counts) 15 bits (0–32767 counts) 14 bits (0–16383 counts) ~15 bits (6553–32767 counts) 15 bits (0–32767 counts) |
| Input Impedance Voltage Modes | 100k Ω |
| Absolute Maximum Input, Voltage Mode | $\pm 30V$ |
| Input Impedance Current Modes | 249 Ω |
| Absolute Maximum Input, Current Mode | $\pm 40mA$ sustained, $\pm 100mA$ for < 5s |
| Conversion Time | 1.2 ms |
| Input Stability | 0.02% of Full Hardware Range = 13 Counts |
| Full Scale Calibration Error | 0.05% of Full Hardware Range = 33 Counts |
| Offset Calibration Error | 0.01% of Full Hardware Range = 7 Counts |
| Accuracy vs Temperature Error | 0.05% of Full Hardware Range = 33 Counts |
| Maximum Linearity Error (End to End) | 0.1% of Full Hardware Range = 66 Counts |
| Maximum Inaccuracy | 0.2% of Full Hardware Range = 131 Counts |
| Fuse Type | User-supplied external fuse |

* Software selectable per channel

BX-DM1E-36ED23 Wiring, Continued

Analog Input Connection Options

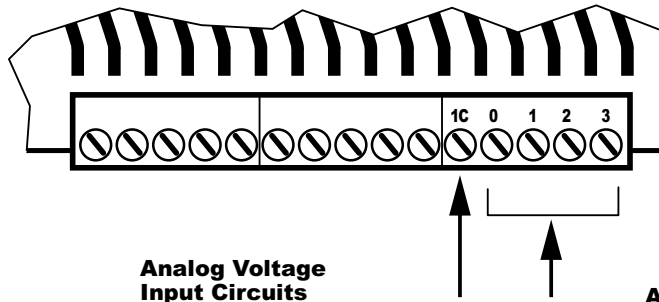

Analog Voltage Input Circuits

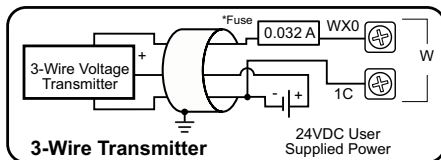
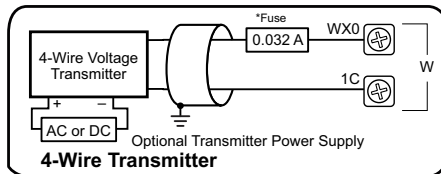

NOTE: Shield should be connected only at one end, to ground at the source device.

Analog Current Sinking Input Circuits

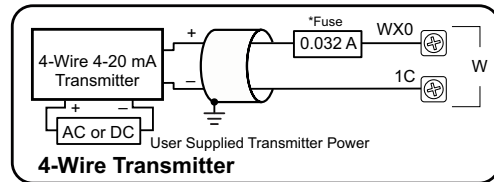
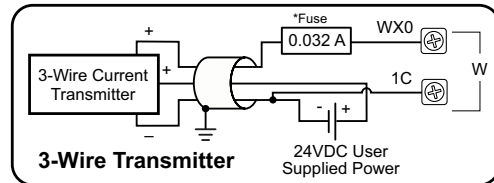
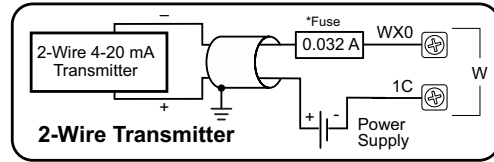

NOTE: Shield should be connected only at one end, to ground at the source device.



NOTE: An Edison S500-32-R 0.032A fast-acting fuse is recommended for all analog voltage inputs, analog outputs, and current loops.

BX-DM1E-36ED23 Wiring, Continued

Analog Output Specifications

| Analog Output Specifications | |
|--|--|
| Outputs per Module | 2 |
| Commons | 3 |
| Output Voltage Range * | Software Selectable $\pm 10V$, $\pm 5V$, 0–10 V, 0–5 V |
| Output Current Range * | Software Selectable $\pm 20mA$, 4–20 mA |
| Resolution $\pm 10V$, $\pm 20mA$ $\pm 5V$ 0–5 V 4–20 mA 0–10 V | 16 bits (0–65535 counts) 15 bits (0–32767 counts) 14 bits (0–16383 counts) ~15 bits (6553–32767 counts) 15 bits (0–32767 counts) |
| Minimum Voltage Load Impedance | 1k Ω |
| Maximum Current Load Impedance | 500 Ω |
| Maximum Rating | Continuous Short Circuit Protected |
| Settling Time | < 1ms |
| Output Stability | 0.02% of Full Hardware Range = 13 Counts |
| Full Scale Calibration Error | 0.05% of Full Hardware Range = 33 Counts |
| Offset Calibration Error | 0.01% of Full Hardware Range = 7 Counts |
| Accuracy vs Temperature Error | 0.05% of Full Hardware Range = 33 Counts |
| Maximum Linearity Error (End to End) | 0.1% of Full Hardware Range = 66 Counts |
| Maximum Inaccuracy | 0.2% of Full Hardware Range = 131 Counts |
| Fuse Type | User-supplied external fuse |

* Software selectable per channel

Analog Output Connection Options

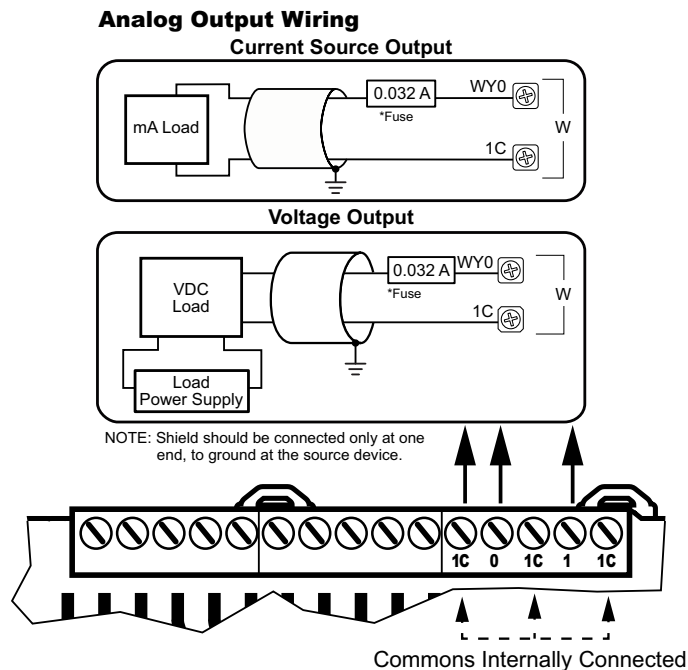

NOTE: An Edison S500-32-R 0.032A fast-acting fuse is recommended for all analog voltage inputs, analog outputs, and current loops.

BX-DM1E-36ED23-D Wiring

This MPU is made up of 36 discrete I/O points. The connections are grouped as follows:

- 20 discrete inputs - sinking/sourcing; rated for 12–24 VAC/VDC. They are located along the bottom of the unit; configured in five (5) groups of 5 terminals, each comprised of 4 inputs and an isolated common.
- 16 discrete outputs - sourcing; rated at 12–24 VDC. They are located along the top of the unit starting to the right of the 24VDC external power supply terminals. The outputs are configured in four (4) groups of 5 terminals, each comprised of 4 outputs and an isolated common.
- 4 analog inputs and 2 analog outputs. The analog inputs are located along the bottom of the unit to the right of the discrete inputs. The analog inputs are grouped together on 5 terminals consisting of 4 input and a shared analog input common. The analog outputs are located along the top of the unit to the right of the discrete outputs. The analog outputs are grouped together on 5 terminals consisting of 2 outputs and 3 shared analog output common terminals. The analog share these common features:
 - current or voltage selectable through software,
 - 16-bit resolution @ $\pm 20\text{mA}$, $\pm 10\text{VDC}$
 - current signal ranges of 4–20 mA, $\pm 20\text{mA}$,
 - voltage signal ranges of 0–5 VDC, 0–10 VDC, $\pm 5\text{VDC}$, $\pm 10\text{VDC}$.

This MPU requires an external 12–24 VDC power supply. The DC power supply connection is located on the top left side of the unit. There is no 24VDC auxiliary output supply.

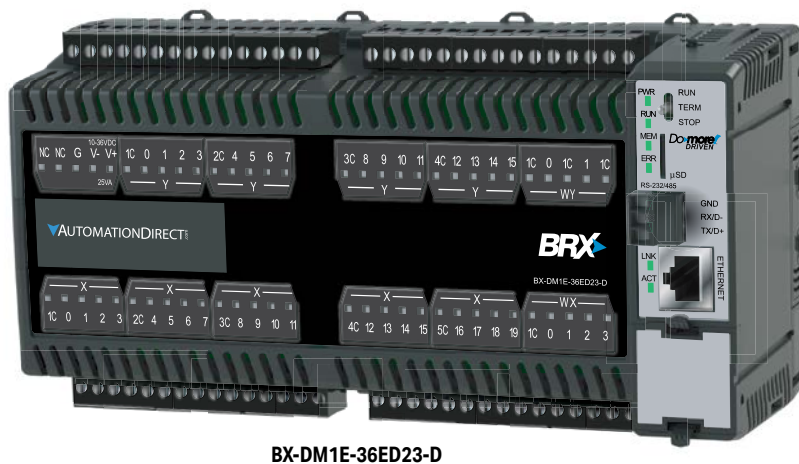

BX-DM1E-36ED23-D



NOTE: Eight (8) Expansion Modules can be connected to extend I/O capacity.

BX-DM1E-36ED23-D, Continued

Power Supply Specifications

| Power Supply Specifications | |
|-------------------------------------|---|
| Nominal Voltage Range* | 12–24 VDC |
| Input Voltage Range (Tolerance)* | 10–36 VDC |
| Maximum Input Voltage Ripple | < ±10% |
| Maximum Input Power | 30W |
| Cold Start Inrush Current | 5A, 2ms |
| Maximum Inrush Current (Hot Start) | 5A, 2ms |
| Internal Input Protection | Reverse polarity protection and undervoltage lockout via transistor circuit |
| Acceptable External Power Drop Time | 10ms |
| Under Input Voltage Lock-out | <9VDC |
| Heat Dissipation | 22.1 W Max |
| Isolated User 24VDC Output | None |
| Voltage Withstand (dielectric) | 1500VAC power Inputs to ground applied for 1 minute |
| Insulation Resistance | >10MΩ @ 500VDC |
| Software Version Required | Do-more! Designer version 2.0 or later |

* Class 2 or LPS Power Supply required.

Power Supply Connections

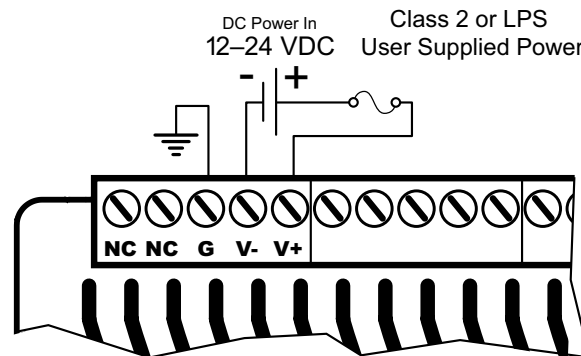

WARNING: No External AC power supply needed on this unit. The two terminals marked "NC" are not used. These terminals are not internally connected. **DO NOT CONNECT ANYTHING TO THESE TERMINALS!**



WARNING: The BRX System **MUST** have a proper earth ground. Do not operate the BRX MPU without proper earth grounding.

BX-DM1E-36ED23-D Wiring, Continued

Discrete Input Specifications

| Discrete Input Specifications | | | |
|-------------------------------|------------------------------|-------------|-----------------------|
| Input Type | Sink/Source | | |
| Total Inputs per Module | 20 | | |
| Commons | 5 (4 points/common) Isolated | | |
| Nominal Voltage Range | 12–24 VAC/VDC | | |
| Input Voltage Range | 9–30 VAC/VDC | | |
| Maximum Voltage | 30 VAC/VDC | | |
| DC Frequency | 0–250 kHz - High-speed | | |
| Minimum Pulse Width | 0.5 μ s - High-speed | | |
| AC Frequency | 47–63 Hz ² | | |
| Input Impedance | 3k Ω @ 24VDC | | |
| Input Current (typical) | 6mA @ 24 VAC/VDC | | |
| Maximum Input Current | 12mA @ 30 VAC/VDC | | |
| ON Voltage Level | > 9.0 VAC/VDC | | |
| OFF Voltage Level | < 2.0 VAC/VDC | | |
| Maximum OFF Current | 1.5 mA | | |
| Status Indicators | Logic Side, Green | | |
| Input Details | | | |
| Input Type | High-Speed DC | | Standard ¹ |
| Location | X0...X9 | | X10...X19 |
| OFF to ON Response | DC | < 2 μ s | 2ms |
| | AC | – | 10ms ² |
| ON to OFF Response | DC | < 2 μ s | 2ms |
| | AC | – | 10ms ² |
| Maximum Switching Frequency | DC | 250kHz | |
| | AC | ~ 30Hz | |

- 1. All inputs may be used as standard inputs. Only the first 10 inputs (X0...X9) are capable of high-speed DC operation.*
- 2. 60Hz to 240Hz filter should be set in the software when using an AC line signal.*

BX-DM1E-36ED23-D Wiring, Continued

Discrete Input Connection Options

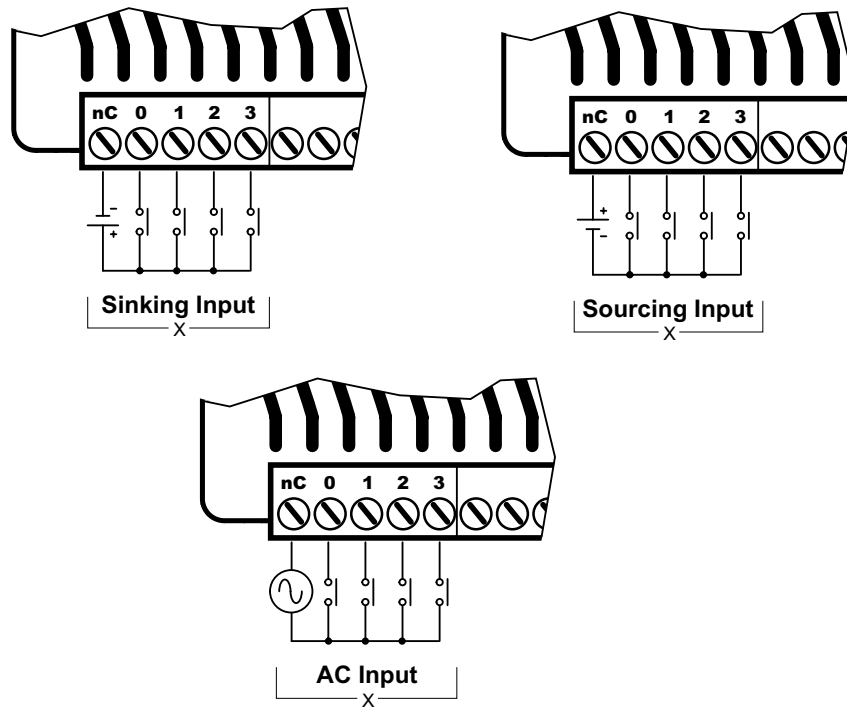

Discrete Input Internal Circuitry *

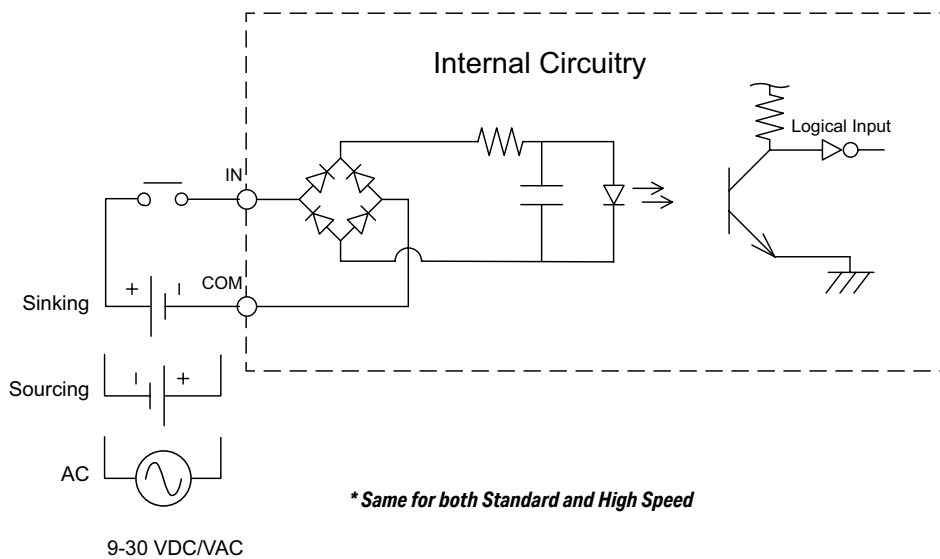

BX-DM1E-36ED23-D Wiring, Continued

Discrete Output Specifications

| Discrete Output Specifications | | |
|---|--|-----------------------|
| Output Type | Sourcing | |
| Total Outputs per Module | 16 | |
| Commons | 4 (4 points/common) Isolated | |
| Maximum Current per Common | 2A | |
| Nominal Voltage Range | 12–24 VDC | |
| Operating Voltage Range | 5–36 VDC | |
| Maximum Voltage | 36VDC | |
| Minimum Output Current | 0.1 mA @ 24VDC | |
| Maximum Output Current | 0.5 A per output No derating over temperature range | |
| Maximum Inrush Current | 5A for 50ms | |
| Maximum Leakage Current | 10 μ A | |
| ON Voltage Drop | 0.05 VDC | |
| Status Indicators | Logic Side, Green | |
| Output Details | | |
| Output Type | High-Speed | Standard ¹ |
| Location | Y0...Y7 | Y8...Y15 |
| OFF to ON Response | < 2 μ s | < 5ms |
| ON to OFF Response | < 2 μ s | < 2ms |
| Maximum Switching Frequency | 1m cable - 250kHz 10m cable - 100kHz | ~100Hz |
| Overcurrent, Short Circuit Protection and Short to Ground | Current limit by Common Group, self-resetting | N/A |
| Overcurrent Trip Level ² | Between 4A and 8A | N/A |
| Fuse Type | User-supplied external fuse | |

- 1. All outputs may be used as standard outputs. Only the first 8 outputs (Y0...Y7) are capable of high-speed DC operation.*
- 2. When the high-speed outputs are in an overcurrent situation, the Common terminal Red LED is on. The output LEDs will remain operational even though the output circuitry is turned off and no power is flowing. This condition is not reported to the CPU.*

BX-DM1E-36ED23-D Wiring, Continued

Discrete Output Connection Options

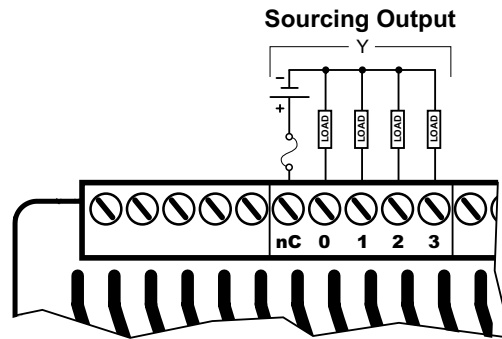

Discrete Standard Output Internal Circuitry

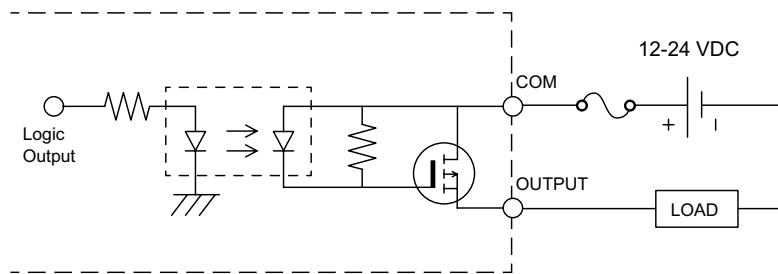

Discrete High-Speed Output Internal Circuitry

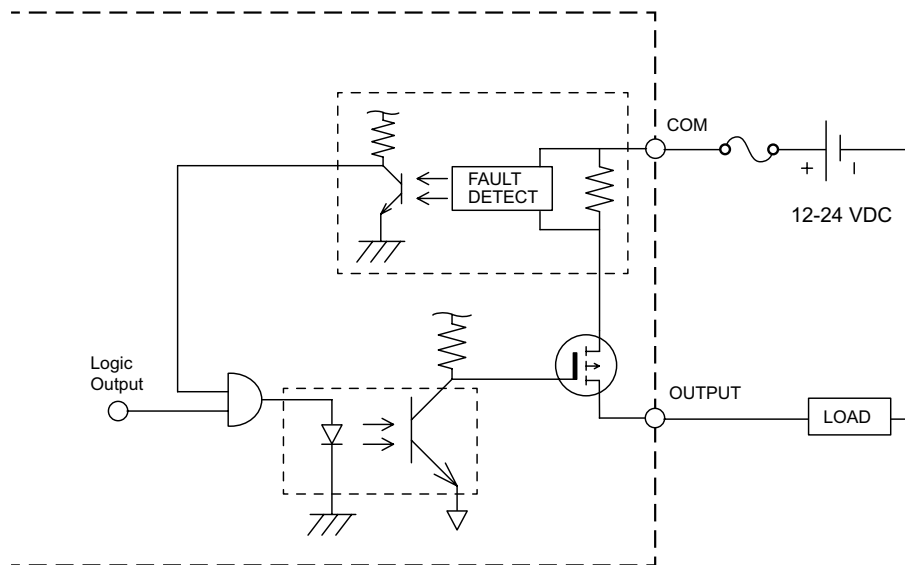

NOTE: When the high speed outputs are in an overcurrent situation, the Common terminal Red LED is on. The output LEDs will remain operational even though the output circuitry is turned off and no power is flowing. This condition is not reported to the CPU.

BX-DM1E-36ED23-D Wiring, Continued

Analog Input Specifications

| Analog Input Specifications | |
|--|--|
| Inputs per Module | 4 |
| Commons | 1 |
| Input Voltage Range * | Software Selectable $\pm 10V$, $\pm 5V$, 0–10 V, 0–5 V |
| Input Current Range * | Software Selectable $\pm 20mA$, 4–20 mA |
| Resolution $\pm 10V$, $\pm 20mA$ $\pm 5V$ 0–5 V 4–20 mA 0–10 V | 16 bits (0–65535 counts) 15 bits (0–32767 counts) 14 bits (0–16383 counts) ~15 bits (6553–32767 counts) 15 bits (0–32767 counts) |
| Input Impedance Voltage Modes | 100k Ω |
| Absolute Maximum Input, Voltage Mode | $\pm 30V$ |
| Input Impedance Current Modes | 249 Ω |
| Absolute Maximum Input, Current Mode | $\pm 40mA$ sustained, $\pm 100mA$ for < 5s |
| Conversion Time | 1.2 ms |
| Input Stability | 0.02% of Full Hardware Range = 13 Counts |
| Full Scale Calibration Error | 0.05% of Full Hardware Range = 33 Counts |
| Offset Calibration Error | 0.01% of Full Hardware Range = 7 Counts |
| Accuracy vs Temperature Error | 0.05% of Full Hardware Range = 33 Counts |
| Maximum Linearity Error (End to End) | 0.1% of Full Hardware Range = 66 Counts |
| Maximum Inaccuracy | 0.2% of Full Hardware Range = 131 Counts |
| Fuse Type | User-supplied external fuse |

* *Software selectable per channel*

BX-DM1E-36ED23-D Wiring, Continued

Analog Input Connection Options

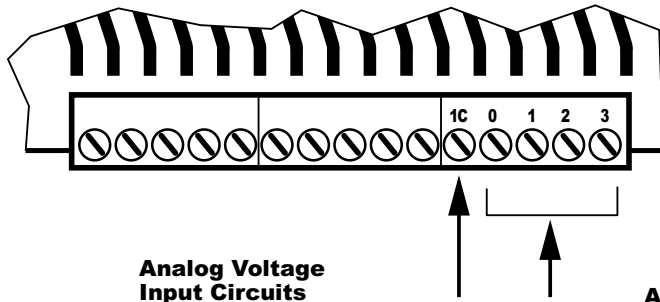

Analog Voltage Input Circuits

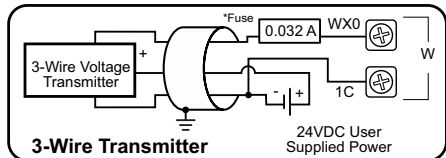
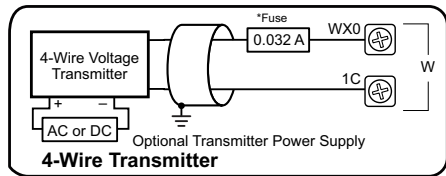

NOTE: Shield should be connected only at one end, to ground at the source device.

Analog Current Sinking Input Circuits

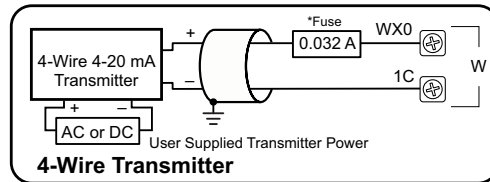
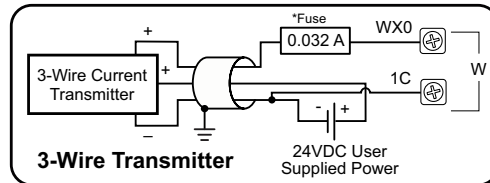
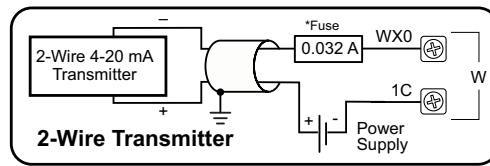

NOTE: Shield should be connected only at one end, to ground at the source device.



NOTE: An Edison S500-32-R 0.032A fast-acting fuse is recommended for all analog voltage inputs, analog outputs, and current loops.

BX-DM1E-36ED23-D Wiring, Continued

Analog Output Specifications

| Analog Output Specifications | |
|--|--|
| Outputs per Module | 2 |
| Commons | 3 |
| Output Voltage Range * | Software Selectable $\pm 10V$, $\pm 5V$, $0-10 V$, $0-5 V$ |
| Output Current Range * | Software Selectable $\pm 20mA$, $4-20 mA$ |
| Resolution $\pm 10V$, $\pm 20mA$ $\pm 5V$ $0-5 V$ $4-20 mA$ $0-10 V$ | 16 bits (0–65535 counts) 15 bits (0–32767 counts) 14 bits (0–16383 counts) ~15 bits (6553–32767 counts) 15 bits (0–32767 counts) |
| Minimum Voltage Load Impedance | 1k Ω |
| Maximum Current Load Impedance | 500 Ω |
| Maximum Rating | Continuous Short Circuit Protected |
| Settling Time | < 1ms |
| Output Stability | 0.02% of Full Hardware Range = 13 Counts |
| Full Scale Calibration Error | 0.05% of Full Hardware Range = 33 Counts |
| Offset Calibration Error | 0.01% of Full Hardware Range = 7 Counts |
| Accuracy vs Temperature Error | 0.05% of Full Hardware Range = 33 Counts |
| Maximum Linearity Error (End to End) | 0.1% of Full Hardware Range = 66 Counts |
| Maximum Inaccuracy | 0.2% of Full Hardware Range = 131 Counts |
| Fuse Type | User-supplied external fuse |

* Software selectable per channel

Analog Output Connection Options

Analog Output Wiring

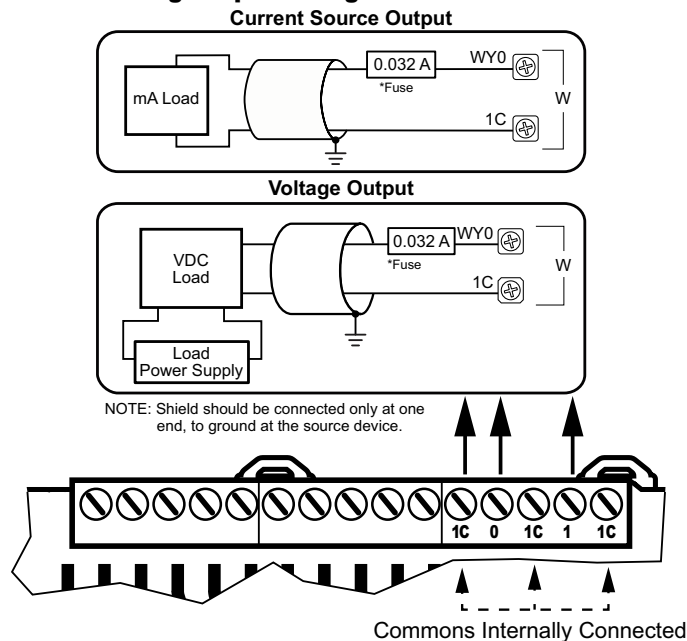

NOTE: An Edison S500-32-R 0.032A fast-acting fuse is recommended for all analog voltage inputs, analog outputs, and current loops.

BX-DM1E-36ER3 Wiring

This MPU is made up of 36 discrete I/O points. The connections are grouped as follows:

- 20 discrete inputs - sinking/sourcing; rated for 12–24 VAC/VDC. They are located along the bottom of the unit; configured in five (5) groups of 5 terminals, each comprised of 4 inputs and an isolated common.
- 16 discrete outputs - Form A Relay (SPST); rated 12–48 VDC/ 24–240 VAC. They are located along the top of the unit starting to the right of the 24VDC auxiliary output terminals. The outputs are configured in four (4) groups of 5 terminals, each comprised of 4 outputs and an isolated common.
- 4 analog inputs and 2 analog outputs. The analog inputs are located along the bottom of the unit to the right of the discrete inputs. The analog inputs are grouped together on 5 terminals consisting of 4 input and a shared analog input common. The analog outputs are located along the top of the unit to the right of the discrete outputs. The analog outputs are grouped together on 5 terminals consisting of 2 outputs and 3 shared analog output common terminals. The analogs share these common features:
 - current or voltage selectable through software,
 - 16-bit resolution @ $\pm 20\text{mA}$, $\pm 10\text{VDC}$
 - current signal ranges of 4–20 mA, $\pm 20\text{mA}$,
 - voltage signal ranges of 0–5 VDC, 0–10 VDC, ± 5 VDC, $\pm 10\text{VDC}$.

This MPU requires an external 120–240 VAC power supply. The AC power supply connection and the 24VDC auxiliary output supply terminals are located on the top left side of the unit.

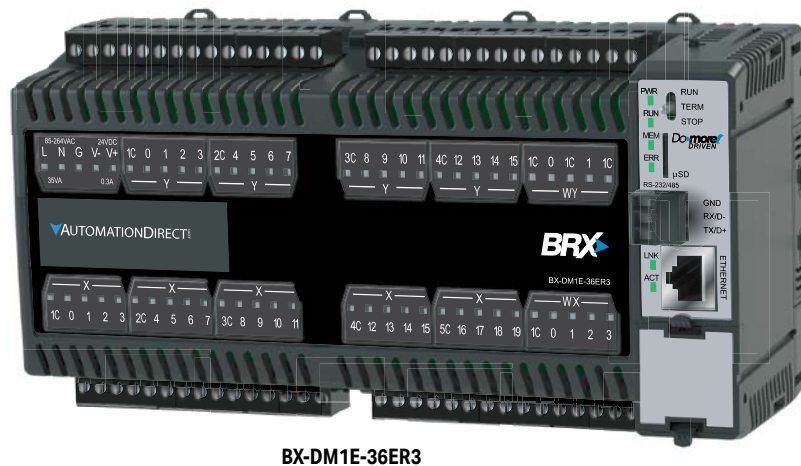

BX-DM1E-36ER3



NOTE: Eight (8) Expansion Modules can be connected to extend I/O capacity.

BX-DM1E-36ER3 Wiring, Continued

Power Supply Specifications

| Power Supply Specifications | |
|-------------------------------------|--|
| Nominal Voltage Range | 120–240 VAC |
| Input Voltage Range (Tolerance) | 85–264 VAC |
| Rated Operating Frequency | 47–63 Hz |
| Maximum Input Power | 40VA |
| Cold Start Inrush Current | 1.5 A, 2ms |
| Maximum Inrush Current (Hot Start) | 1.5 A, 2ms |
| Internal Input Fuse Protection | Micro fuse 250V, 2A Non-replaceable |
| Acceptable External Power Drop Time | 10ms |
| Under Input Voltage Lock-out | 80VAC |
| Input Transient Protection | Input choke and line filter |
| Heat Dissipation | 27.6 W Max |
| Isolated User 24VDC Output | 24VDC @ 0.3 A max, <1V P-P Ripple, Integrated self-resetting short circuit protection |
| Voltage Withstand (dielectric) | 1500VAC Power Inputs to Ground applied for 1 minute 1500VAC Ground to 24VDC Output applied for 1 minute |
| Insulation Resistance | >10MΩ @ 500VDC |
| Software Version Required | Do-more! Designer version 2.0 or later |

Power Supply Connections

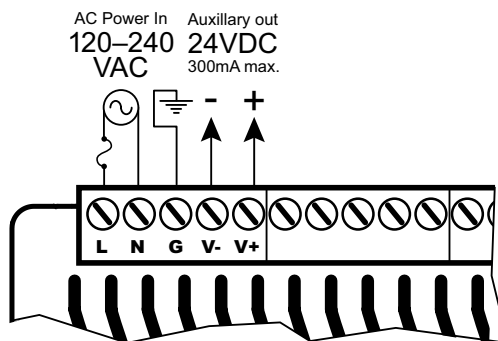

WARNING: Do not exceed the 24VDC auxiliary power supply load limit of 300mA.



WARNING: The BRX System **MUST** have a proper earth ground. Do not operate the BRX MPU without proper earth grounding.

BX-DM1E-36ER3 Wiring, Continued

Discrete Input Specifications

| Discrete Input Specifications | | | |
|-------------------------------|------------------------------|-------------|-----------------------|
| Input Type | Sink/Source | | |
| Total Inputs per Module | 20 | | |
| Commons | 5 (4 points/common) Isolated | | |
| Nominal Voltage Range | 12–24 VAC/VDC | | |
| Input Voltage Range | 9–30 VAC/VDC | | |
| Maximum Voltage | 30 VAC/VDC | | |
| DC Frequency | 0–250 kHz - High-speed | | |
| Minimum Pulse Width | 0.5 μ s - High-speed | | |
| AC Frequency | 47–63 Hz ² | | |
| Input Impedance | 3k Ω @ 24VDC | | |
| Input Current (typical) | 6mA @ 24 VAC/VDC | | |
| Maximum Input Current | 12mA @ 30 VAC/VDC | | |
| ON Voltage Level | > 9.0 VAC/VDC | | |
| OFF Voltage Level | < 2.0 VAC/VDC | | |
| Maximum OFF Current | 1.5 mA | | |
| Status Indicators | Logic Side, Green | | |
| Input Details | | | |
| Input Type | High-Speed DC | | Standard ¹ |
| Location | X0...X9 | | X10...X19 |
| OFF to ON Response | DC | < 2 μ s | 2ms |
| | AC | – | 10ms ² |
| ON to OFF Response | DC | < 2 μ s | 2ms |
| | AC | – | 10ms ² |
| Maximum Switching Frequency | DC | 250kHz | |
| | AC | ~ 30Hz | |

1. All inputs may be used as standard inputs. Only the first 10 inputs (X0...X9) are capable of high-speed DC operation.

2. 60Hz to 240Hz filter should be set in the software when using an AC line signal.

BX-DM1E-36ER3 Wiring, Continued

Discrete Input Connection Options

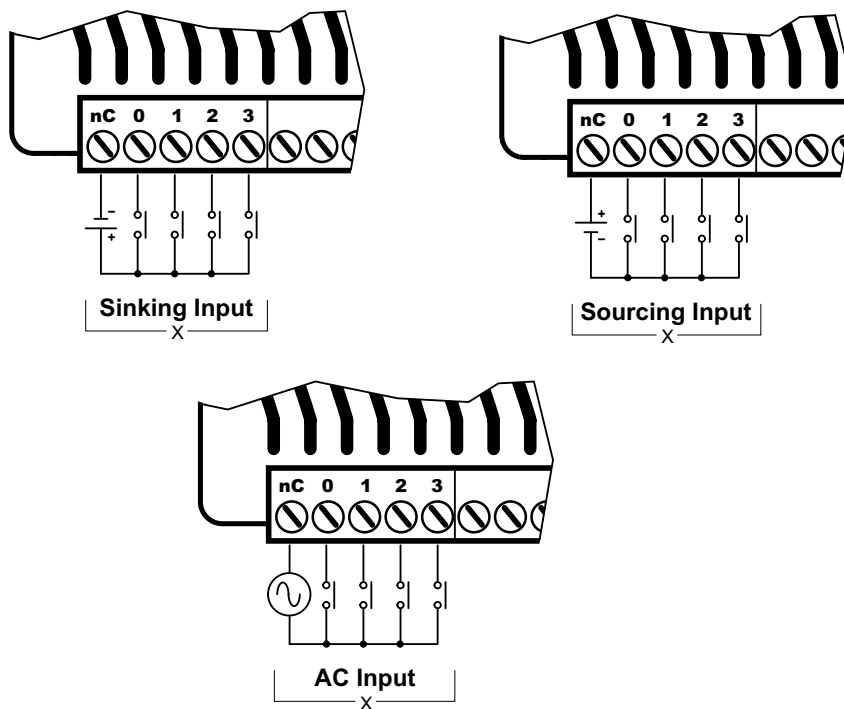

Discrete Input Internal Circuitry *

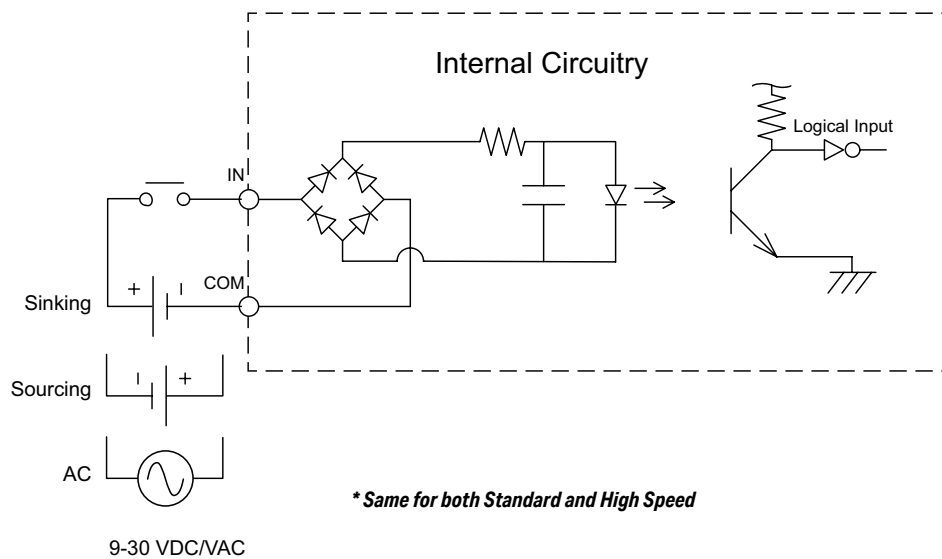

BX-DM1E-36ER3 Wiring, Continued

Discrete Output Specifications

| Discrete Output Specifications | |
|--------------------------------|--|
| Output Type | Relay Form A (SPST) |
| Total Outputs per Module | 16 |
| Commons | 4 (4 points/common) Isolated |
| Maximum Current per Common | 8A |
| Nominal Voltage Range | 12–48 VDC 24–240 VAC |
| Operating Voltage Range | 5–60 VDC 5–264 VAC |
| Maximum Voltage | 60VDC 264VAC |
| Minimum Output Current | 0.1 mA @ 24VDC 0.1 mA @ 24VAC |
| Maximum Output Current | 2A |
| Maximum Inrush Current | 5A for 50ms |
| Maximum Leakage Current | 1 μ A (DC), 300 μ A (AC) due to RC snubber circuit |
| ON Voltage Drop | 0.2 V Max |
| Status Indicators | Logic Side, Green |
| Output Details | |
| Output Type | Standard |
| Location | Y0...Y15 |
| ON-OFF Response | <10ms |
| OFF-ON Response | <10ms |
| Maximum Switching Frequency | 10Hz |
| Relay Cycle Life | 5 million operations |
| Mechanical Endurance | 120,000 operations |
| Electrical Endurance | |
| Fuse Type | User-supplied external fuse |

BX-DM1E-36ER3 Wiring, Continued

Discrete Output Connection Options

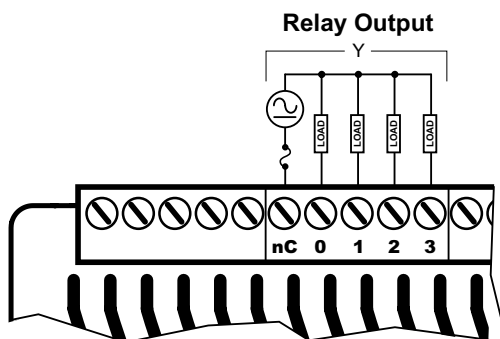

Discrete Standard Output Internal Circuitry

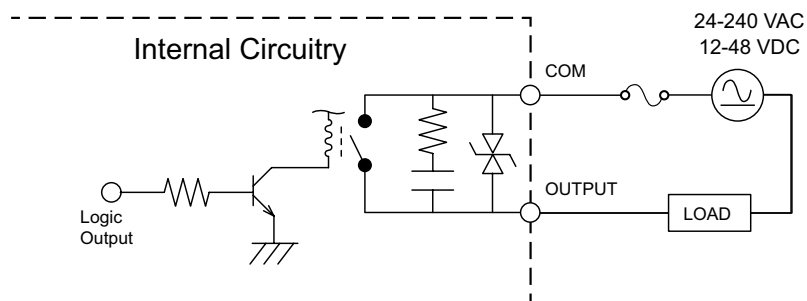

BX-DM1E-36ER3 Wiring, Continued

Analog Input Specifications

| Analog Input Specifications | |
|--|--|
| Inputs per Module | 4 |
| Commons | 1 |
| Input Voltage Range * | Software Selectable $\pm 10V$, $\pm 5V$, 0–10 V, 0–5 V |
| Input Current Range * | Software Selectable $\pm 20mA$, 4–20 mA |
| Resolution $\pm 10V$, $\pm 20mA$ $\pm 5V$ 0–5 V 4–20 mA 0–10 V | 16 bits (0–65535 counts) 15 bits (0–32767 counts) 14 bits (0–16383 counts) ~15 bits (6553–32767 counts) 15 bits (0–32767 counts) |
| Input Impedance Voltage Modes | 100k Ω |
| Absolute Maximum Input, Voltage Mode | $\pm 30V$ |
| Input Impedance Current Modes | 249 Ω |
| Absolute Maximum Input, Current Mode | $\pm 40mA$ sustained, $\pm 100mA$ for < 5s |
| Conversion Time | 1.2 ms |
| Input Stability | 0.02% of Full Hardware Range = 13 Counts |
| Full Scale Calibration Error | 0.05% of Full Hardware Range = 33 Counts |
| Offset Calibration Error | 0.01% of Full Hardware Range = 7 Counts |
| Accuracy vs Temperature Error | 0.05% of Full Hardware Range = 33 Counts |
| Maximum Linearity Error (End to End) | 0.1% of Full Hardware Range = 66 Counts |
| Maximum Inaccuracy | 0.2% of Full Hardware Range = 131 Counts |
| Fuse Type | User-supplied external fuse |

* *Software selectable per channel*

BX-DM1E-36ER3 Wiring, Continued

Analog Input Connection Options

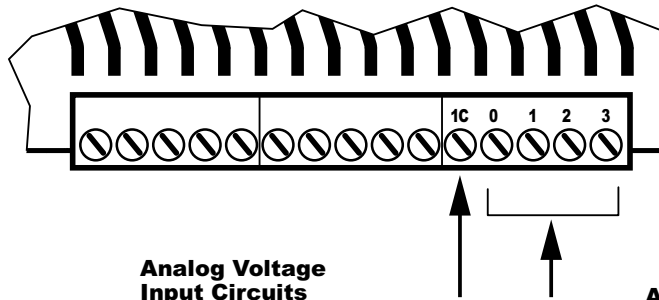

Analog Voltage Input Circuits

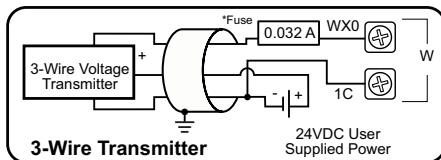
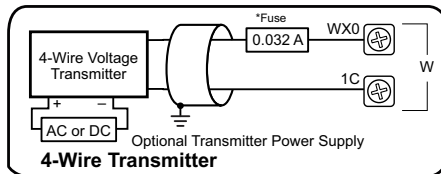

NOTE: Shield should be connected only at one end, to ground at the source device.

Analog Current Sinking Input Circuits

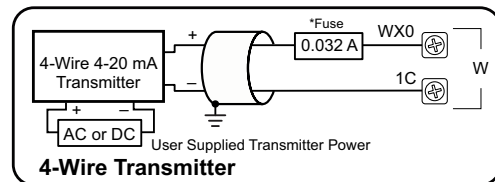
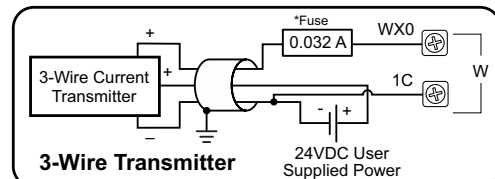
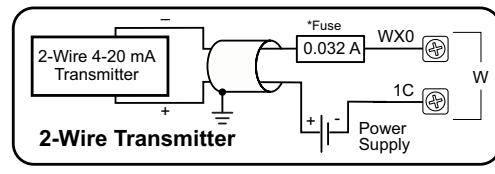

NOTE: Shield should be connected only at one end, to ground at the source device.



NOTE: An Edison S500-32-R 0.032A fast-acting fuse is recommended for all analog voltage inputs, analog outputs, and current loops.

BX-DM1E-36ER3 Wiring, Continued

Analog Output Specifications

| Analog Output Specifications | |
|--|--|
| Outputs per Module | 2 |
| Commons | 3 |
| Output Voltage Range * | Software Selectable $\pm 10V$, $\pm 5V$, 0–10 V, 0–5 V |
| Output Current Range * | Software Selectable $\pm 20mA$, 4–20 mA |
| Resolution $\pm 10V$, $\pm 20mA$ $\pm 5V$ 0–5 V 4–20 mA 0–10 V | 16 bits (0–65535 counts) 15 bits (0–32767 counts) 14 bits (0–16383 counts) ~15 bits (6553–32767 counts) 15 bits (0–32767 counts) |
| Minimum Voltage Load Impedance | 1k Ω |
| Maximum Current Load Impedance | 500 Ω |
| Maximum Rating | Continuous Short Circuit Protected |
| Settling Time | < 1ms |
| Output Stability | 0.02% of Full Hardware Range = 13 Counts |
| Full Scale Calibration Error | 0.05% of Full Hardware Range = 33 Counts |
| Offset Calibration Error | 0.01% of Full Hardware Range = 7 Counts |
| Accuracy vs Temperature Error | 0.05% of Full Hardware Range = 33 Counts |
| Maximum Linearity Error (End to End) | 0.1% of Full Hardware Range = 66 Counts |
| Maximum Inaccuracy | 0.2% of Full Hardware Range = 131 Counts |
| Fuse Type | User-supplied external fuse |

* Software selectable per channel

Analog Output Connection Options

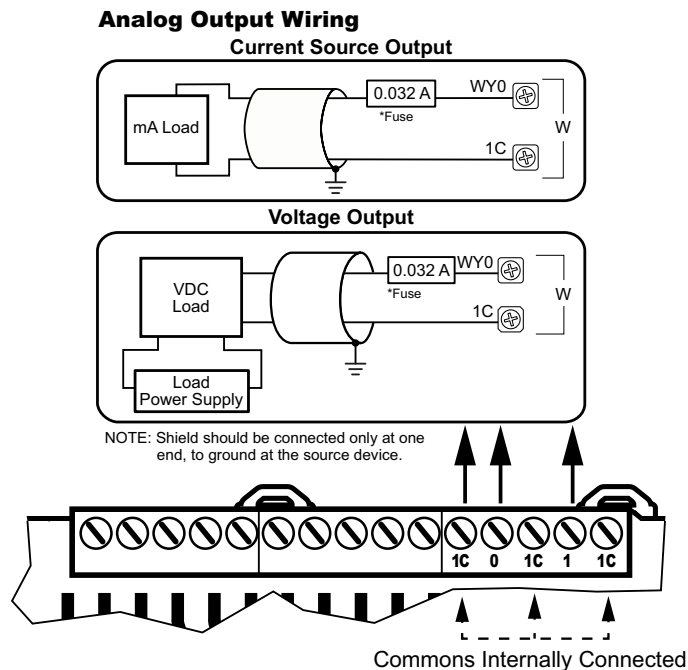

NOTE: An Edison S500-32-R 0.032A fast-acting fuse is recommended for all analog voltage inputs, analog outputs, and current loops.

BX-DM1E-36ER3-D Wiring

This MPU is made up of 36 discrete I/O points. The connections are grouped as follows:

- 20 discrete inputs - sinking/sourcing; rated for 12–24 VAC/VDC. They are located along the bottom of the unit; configured in five (5) groups of 5 terminals, each comprised of 4 inputs and an isolated common.
- 16 discrete outputs - Form A Relay (SPST); rated 12–48 VDC/ 24–240 VAC. They are located along the top of the unit starting to the right of the 24VDC external power supply terminals. The outputs are configured in four (4) groups of 5 terminals, each comprised of 4 outputs and an isolated common.
- 4 analog inputs and 2 analog outputs. The analog inputs are located along the bottom of the unit to the right of the discrete inputs. The analog inputs are grouped together on 5 terminals consisting of 4 input and a shared analog input common. The analog outputs are located along the top of the unit to the right of the discrete outputs. The analog outputs are grouped together on 5 terminals consisting of 2 outputs and 3 shared analog output common terminals. The analogs share these common features:
 - current or voltage selectable through software
 - 16-bit resolution @ $\pm 20\text{mA}$, $\pm 10\text{VDC}$
 - current signal ranges of 4–20 mA, $\pm 20\text{mA}$
 - voltage signal ranges of 0–5 VDC, 0–10 VDC, $\pm 5\text{VDC}$, $\pm 10\text{VDC}$

This MPU requires an external 12–24 VDC power supply. The DC power supply connection is located on the top left side of the unit. There is no 24VDC auxiliary output supply.

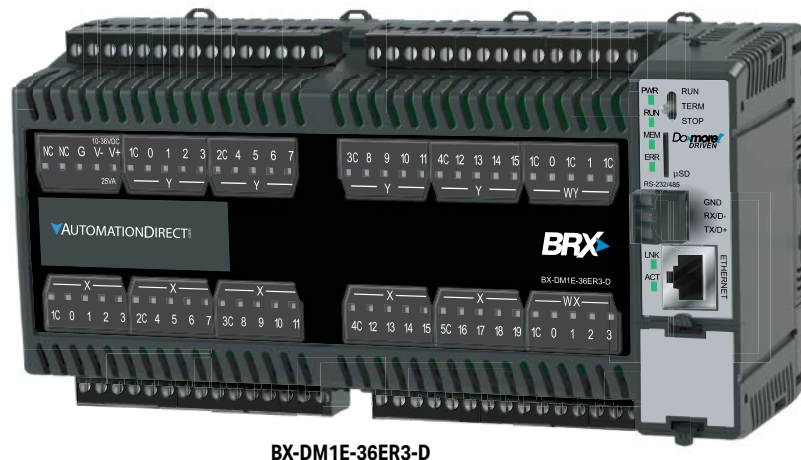

BX-DM1E-36ER3-D



NOTE: Eight (8) Expansion Modules can be connected to extend I/O capacity.

BX-DM1E-36ER3-D Wiring, Continued

Power Supply Specifications

| Power Supply Specifications | |
|-------------------------------------|---|
| Nominal Voltage Range* | 12–24 VDC |
| Input Voltage Range (Tolerance)* | 10–36 VDC |
| Maximum Input Voltage Ripple | < ±10% |
| Maximum Input Power | 30W |
| Cold Start Inrush Current | 5A, 2ms |
| Maximum Inrush Current (Hot Start) | 5A, 2ms |
| Internal Input Protection | Reverse polarity protection and undervoltage lockout via transistor circuit |
| Acceptable External Power Drop Time | 10ms |
| Under Input Voltage Lock-out | <9VDC |
| Heat Dissipation | 25.4 W Max |
| Isolated User 24VDC Output | None |
| Voltage Withstand (dielectric) | 1500VAC power Inputs to ground applied for 1 minute |
| Insulation Resistance | >10MΩ @ 500VDC |
| Software Version Required | Do-more! Designer version 2.0 or later |

* Class 2 or LPS Power Supply required.

Power Supply Connections

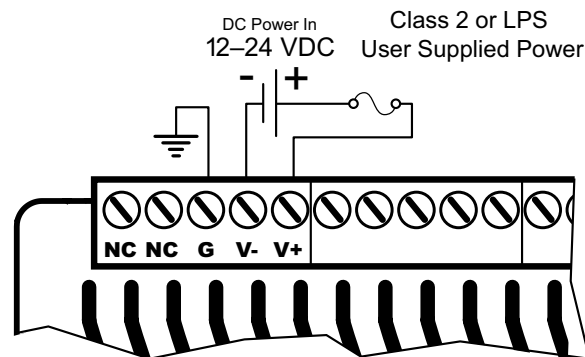

WARNING: No External AC power supply needed on this unit. The two terminals marked "NC" are not used. These terminals are not internally connected. **DO NOT CONNECT ANYTHING TO THESE TERMINALS!**



WARNING: The BRX System **MUST** have a proper earth ground. Do not operate the BRX MPU without proper earth grounding.

BX-DM1E-36ER3-D Wiring, Continued

Discrete Input Specifications

| Discrete Input Specifications | | | |
|-------------------------------|------------------------------|-------------|-----------------------|
| Input Type | Sink/Source | | |
| Total Inputs per Module | 20 | | |
| Commons | 5 (4 points/common) Isolated | | |
| Nominal Voltage Range | 12–24 VAC/VDC | | |
| Input Voltage Range | 9–30 VAC/VDC | | |
| Maximum Voltage | 30 VAC/VDC | | |
| DC Frequency | 0–250 kHz - High-speed | | |
| Minimum Pulse Width | 0.5 μ s - High-speed | | |
| AC Frequency | 47–63 Hz ² | | |
| Input Impedance | 3k Ω @ 24VDC | | |
| Input Current (typical) | 6mA @ 24 VAC/VDC | | |
| Maximum Input Current | 12mA @ 30 VAC/VDC | | |
| ON Voltage Level | > 9.0 VAC/VDC | | |
| OFF Voltage Level | < 2.0 VAC/VDC | | |
| Maximum OFF Current | 1.5 mA | | |
| Status Indicators | Logic Side, Green | | |
| Input Details | | | |
| Input Type | High-Speed DC | | Standard ¹ |
| Location | X0...X9 | | X10...X19 |
| OFF to ON Response | DC | < 2 μ s | 2ms |
| | AC | – | 10ms ² |
| ON to OFF Response | DC | < 2 μ s | 2ms |
| | AC | – | 10ms ² |
| Maximum Switching Frequency | DC | 250kHz | |
| | AC | ~ 30Hz | |

- 1. All inputs may be used as standard inputs. Only the first 10 inputs (X0...X9) are capable of high-speed DC operation.*
- 2. 60Hz to 240Hz filter should be set in the software when using an AC line signal.*

BX-DM1E-36ER3-D Wiring, Continued

Discrete Input Connection Options

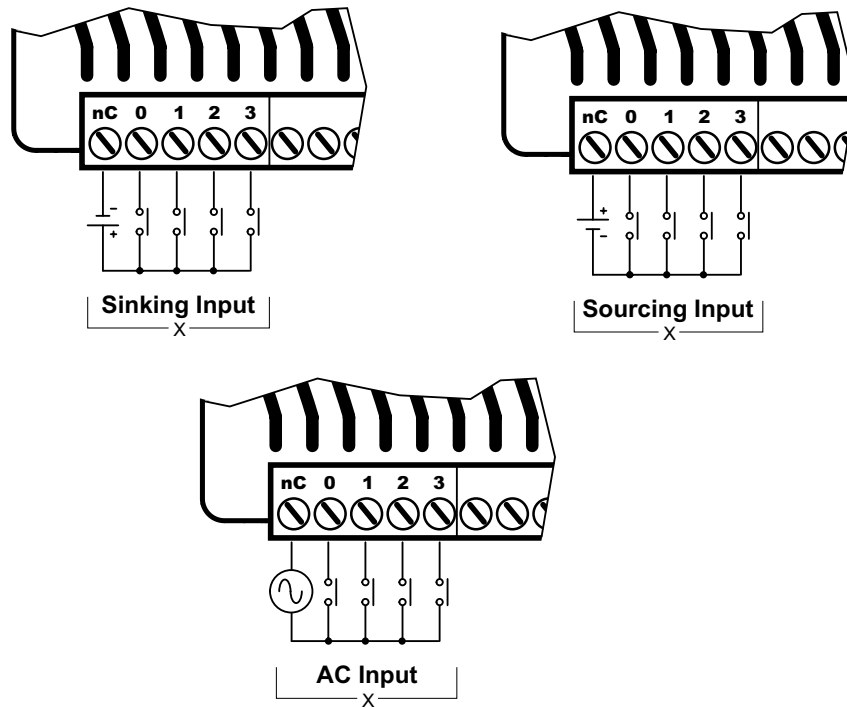

Discrete Input Internal Circuitry *

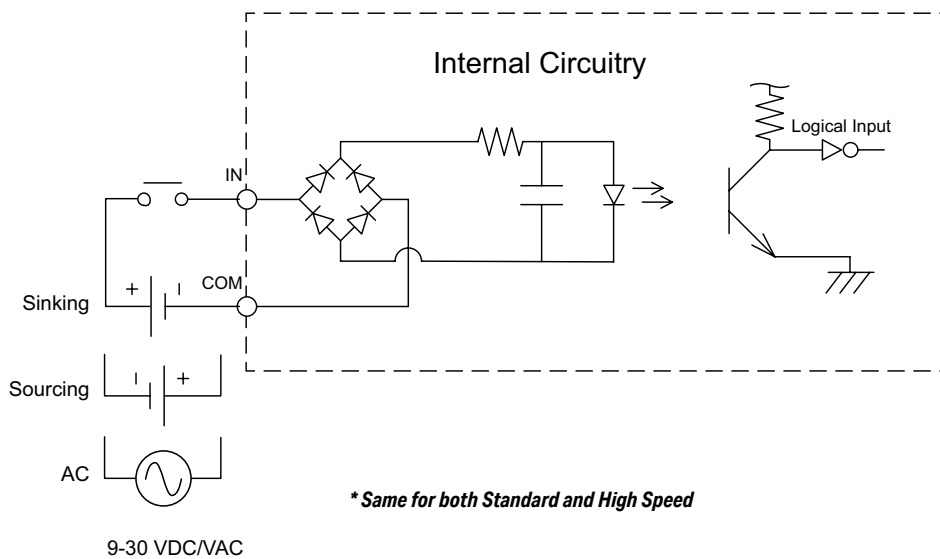

BX-DM1E-36ER3-D Wiring, Continued

Discrete Output Specifications

| Discrete Output Specifications | |
|--------------------------------|--|
| Output Type | Relay Form A (SPST) |
| Total Outputs per Module | 16 |
| Commons | 4 (4 points/common) Isolated |
| Maximum Current per Common | 8A |
| Nominal Voltage Range | 12–48 VDC 24–240 VAC |
| Operating Voltage Range | 5–60 VDC 5–264 VAC |
| Maximum Voltage | 60VDC 264VAC |
| Minimum Output Current | 0.1 mA @ 24VDC 0.1 mA @ 24VAC |
| Maximum Output Current | 2A |
| Maximum Inrush Current | 5A for 50ms |
| Maximum Leakage Current | 1 μ A (DC), 300 μ A (AC) due to RC snubber circuit |
| ON Voltage Drop | 0.2 V Max |
| Status Indicators | Logic Side, Green |
| Output Details | |
| Output Type | Standard |
| Location | Y0...Y15 |
| ON-OFF Response | <10ms |
| OFF-ON Response | <10ms |
| Maximum Switching Frequency | 10Hz |
| Relay Cycle Life | 5 million operations |
| Mechanical Endurance | 120,000 operations |
| Electrical Endurance | |
| Fuse Type | User-supplied external fuse |

BX-DM1E-36ER3-D Wiring, Continued

Discrete Output Connection Options

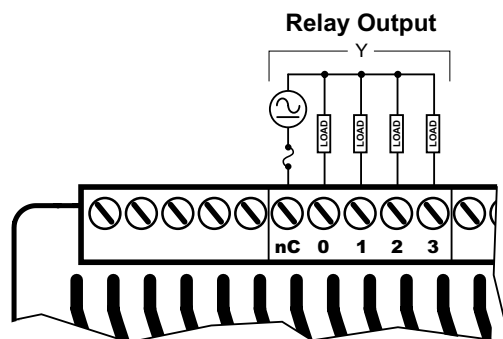

Discrete Standard Output Internal Circuitry

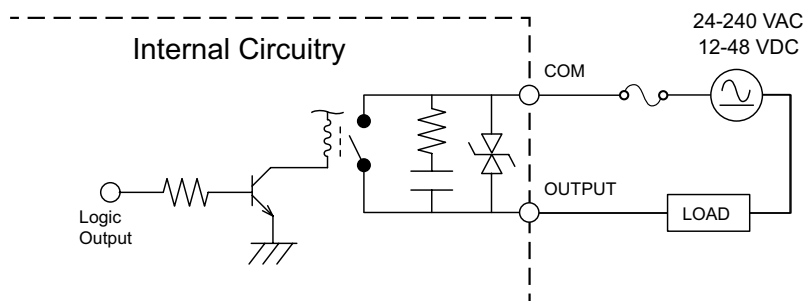

BX-DM1E-36ER3-D Wiring, Continued

Analog Input Specifications

| Analog Input Specifications | |
|--|--|
| Inputs per Module | 4 |
| Commons | 1 |
| Input Voltage Range * | Software Selectable $\pm 10V$, $\pm 5V$, 0–10 V, 0–5 V |
| Input Current Range * | Software Selectable $\pm 20mA$, 4–20 mA |
| Resolution $\pm 10V$, $\pm 20mA$ $\pm 5V$ 0–5 V 4–20 mA 0–10 V | 16 bits (0–65535 counts) 15 bits (0–32767 counts) 14 bits (0–16383 counts) ~15 bits (6553–32767 counts) 15 bits (0–32767 counts) |
| Input Impedance Voltage Modes | 100k Ω |
| Absolute Maximum Input, Voltage Mode | $\pm 30V$ |
| Input Impedance Current Modes | 249 Ω |
| Absolute Maximum Input, Current Mode | $\pm 40mA$ sustained, $\pm 100mA$ for < 5s |
| Conversion Time | 1.2 ms |
| Input Stability | 0.02% of Full Hardware Range = 13 Counts |
| Full Scale Calibration Error | 0.05% of Full Hardware Range = 33 Counts |
| Offset Calibration Error | 0.01% of Full Hardware Range = 7 Counts |
| Accuracy vs Temperature Error | 0.05% of Full Hardware Range = 33 Counts |
| Maximum Linearity Error (End to End) | 0.1% of Full Hardware Range = 66 Counts |
| Maximum Inaccuracy | 0.2% of Full Hardware Range = 131 Counts |
| Fuse Type | User-supplied external fuse |

* *Software selectable per channel*

BX-DM1E-36ER3-D Wiring, Continued

Analog Input Connection Options

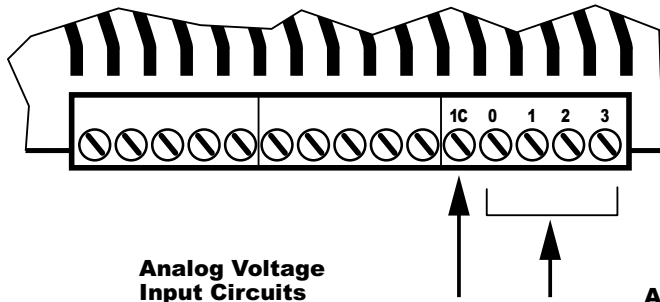

Analog Voltage Input Circuits

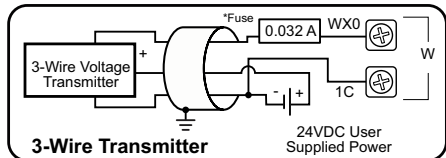
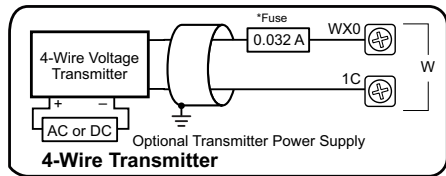

NOTE: Shield should be connected only at one end, to ground at the source device.

Analog Current Sinking Input Circuits

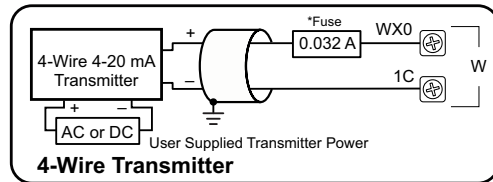
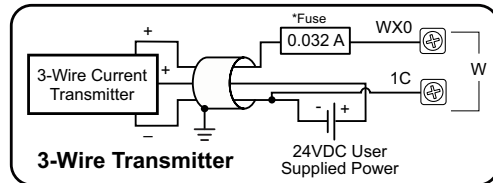
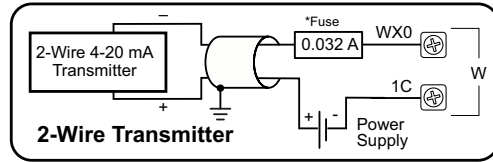

NOTE: Shield should be connected only at one end, to ground at the source device.



NOTE: An Edison S500-32-R 0.032A fast-acting fuse is recommended for all analog voltage inputs, analog outputs, and current loops.

BX-DM1E-36ER3-D Wiring, Continued

Analog Output Specifications

| Analog Output Specifications | |
|--|--|
| Outputs per Module | 2 |
| Commons | 3 |
| Output Voltage Range * | Software Selectable $\pm 10V$, $\pm 5V$, 0–10 V, 0–5 V |
| Output Current Range * | Software Selectable $\pm 20mA$, 4–20 mA |
| Resolution $\pm 10V$, $\pm 20mA$ $\pm 5V$ 0–5 V 4–20 mA 0–10 V | 16 bits (0–65535 counts) 15 bits (0–32767 counts) 14 bits (0–16383 counts) ~15 bits (6553–32767 counts) 15 bits (0–32767 counts) |
| Minimum Voltage Load Impedance | 1k Ω |
| Maximum Current Load Impedance | 500 Ω |
| Maximum Rating | Continuous Short Circuit Protected |
| Settling Time | < 1ms |
| Output Stability | 0.02% of Full Hardware Range = 13 Counts |
| Full Scale Calibration Error | 0.05% of Full Hardware Range = 33 Counts |
| Offset Calibration Error | 0.01% of Full Hardware Range = 7 Counts |
| Accuracy vs Temperature Error | 0.05% of Full Hardware Range = 33 Counts |
| Maximum Linearity Error (End to End) | 0.1% of Full Hardware Range = 66 Counts |
| Maximum Inaccuracy | 0.2% of Full Hardware Range = 131 Counts |
| Fuse Type | User-supplied external fuse |

* Software selectable per channel

Analog Output Connection Options

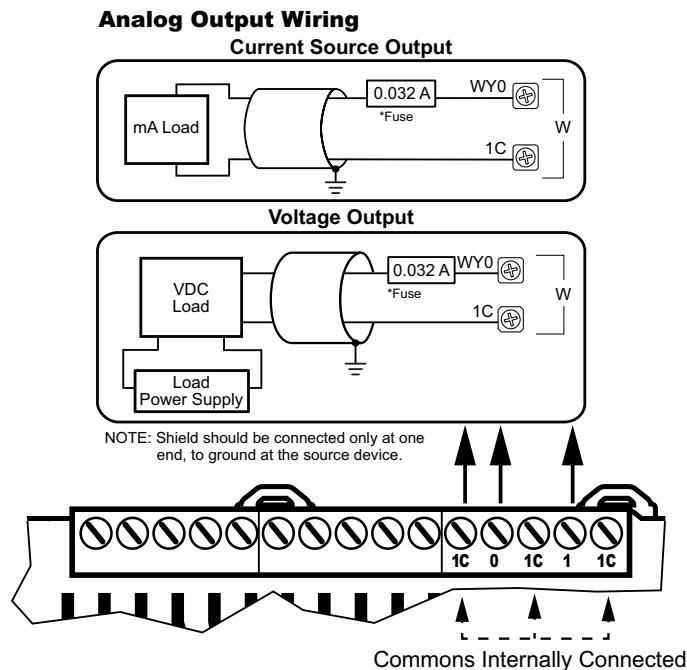

NOTE: An Edison S500-32-R 0.032A fast-acting fuse is recommended for all analog voltage inputs, analog outputs, and current loops.

BX-DM1E-36AR3 Wiring

This MPU is made up of 36 discrete I/O points. The connections are grouped as follows:

- 20 discrete inputs - AC rated for 120–240 VAC. They are located along the bottom of the unit; configured in five (5) groups of 5 terminals, each comprised of 4 inputs and an isolated common.
- 16 discrete outputs - Form A Relay (SPST); rated 12–48 VDC/ 24–240 VAC. They are located along the top of the unit starting to the right of the 24VDC auxiliary output terminals. The outputs are configured in four (4) groups of 5 terminals, each comprised of 4 outputs and an isolated common.
- 4 analog inputs and 2 analog outputs. The analog inputs are located along the bottom of the unit to the right of the discrete inputs. The analog inputs are grouped together on 5 terminals consisting of 4 input and a shared analog input common. The analog outputs are located along the top of the unit to the right of the discrete outputs. The analog outputs are grouped together on 5 terminals consisting of 2 outputs and 3 shared analog output common terminals. The analogs share these common features:
 - current or voltage selectable through software,
 - 16-bit resolution @ $\pm 20\text{mA}$, $\pm 10\text{VDC}$
 - current signal ranges of 4–20 mA, $\pm 20\text{mA}$,
 - voltage signal ranges of 0–5 VDC, 0–10 VDC, $\pm 5\text{VDC}$, $\pm 10\text{VDC}$.

This MPU requires an external 120–240 VAC power supply. The AC power supply connection and the 24VDC auxiliary output supply terminals are located on the top left side of the unit.

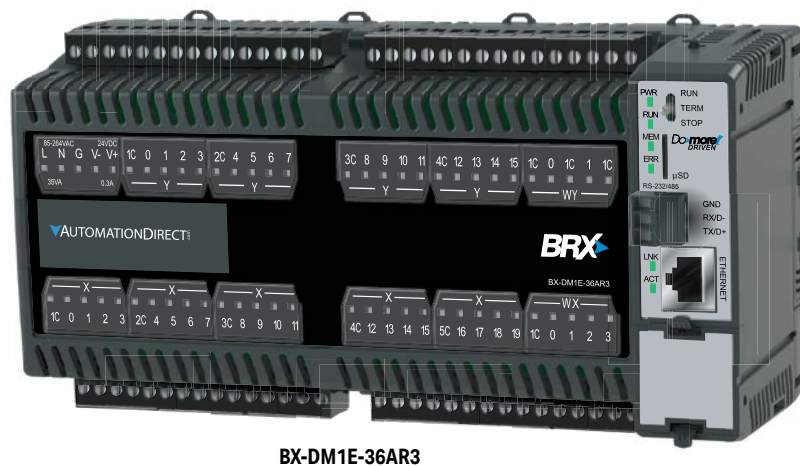

BX-DM1E-36AR3



NOTE: Eight (8) Expansion Modules can be connected to extend I/O capacity.

BX-DM1E-36AR3 Wiring, Continued

Power Supply Specifications

| Power Supply Specifications | |
|-------------------------------------|--|
| Nominal Voltage Range | 120–240 VAC |
| Input Voltage Range (Tolerance) | 85–264 VAC |
| Rated Operating Frequency | 47–63 Hz |
| Maximum Input Power | 40VA |
| Cold Start Inrush Current | 1.5 A, 2ms |
| Maximum Inrush Current (Hot Start) | 1.5 A, 2ms |
| Internal Input Fuse Protection | Micro fuse 250V, 2A Non-replaceable |
| Acceptable External Power Drop Time | 10ms |
| Under Input Voltage Lock-out | 80VAC |
| Input Transient Protection | Input choke and line filter |
| Heat Dissipation | 26.8 W Max |
| Isolated User 24VDC Output | 24VDC @ 0.3 A max, <1V P-P Ripple, Integrated self-resetting short circuit protection |
| Voltage Withstand (dielectric) | 1500VAC Power Inputs to Ground applied for 1 minute 1500VAC Ground to 24VDC Output applied for 1 minute |
| Insulation Resistance | >10M Ω @ 500VDC |
| Software Version Required | Do-more! Designer version 2.0 or later |

Power Supply Connections

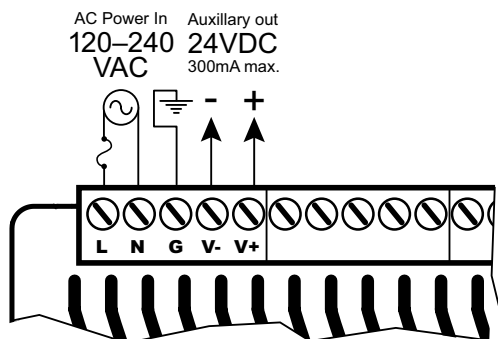

WARNING: Do not exceed the 24VDC auxiliary power supply load limit of 300mA.



WARNING: The BRX System **MUST** have a proper earth ground. Do not operate the BRX MPU without proper earth grounding.

BX-DM1E-36AR3 Wiring, Continued

Discrete Input Specifications

| Discrete Input Specifications | |
|-------------------------------|------------------------------|
| Input Type | AC |
| Total Inputs per Module | 20 |
| Commons | 5 (4 points/common) Isolated |
| Nominal Voltage Range | 120–240 VAC |
| Input Voltage Range | 85–264 VAC |
| Maximum Voltage | 264VAC RMS |
| AC Frequency | 47–63 Hz |
| Input Impedance | 15k Ω |
| Input Current (typical) | 9mA @ 120VAC, 13mA @ 220VAC |
| Maximum Input Current | 14mA @ 120VAC, 20mA @ 220VAC |
| ON Voltage Level | > 85VAC |
| OFF Voltage Level | < 40VAC |
| Maximum OFF Current | 2.5 mA |
| Status Indicators | Logic Side, Green |
| Input Details | |
| Input Type | Standard |
| Location | X0...X19 |
| OFF - ON Response | 10ms |
| ON - OFF Response | 10ms |
| Maximum Switching Frequency | ~ 30Hz |

Discrete Input Connection Options

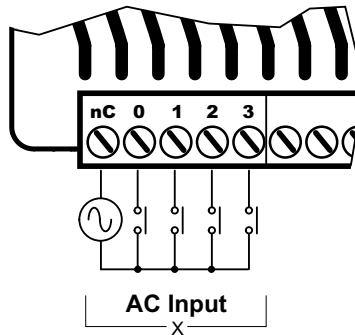

Discrete Input Internal Circuitry

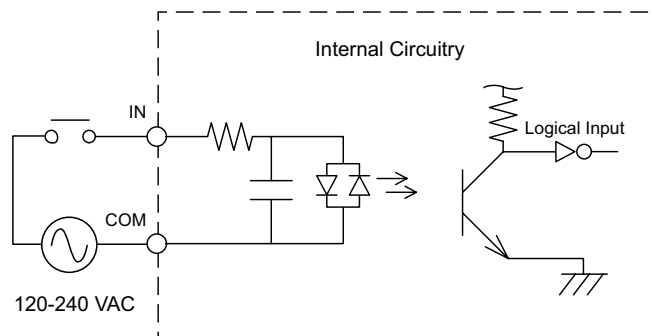

BX-DM1E-36AR3 Wiring, Continued

Discrete Output Specifications

| Discrete Output Specifications | |
|--------------------------------|--|
| Output Type | Relay Form A (SPST) |
| Total Outputs per Module | 16 |
| Commons | 4 (4 points/common) Isolated |
| Maximum Current per Common | 8A |
| Nominal Voltage Range | 12–48 VDC 24–240 VAC |
| Operating Voltage Range | 5–60 VDC 5–264 VAC |
| Maximum Voltage | 60VDC 264VAC |
| Minimum Output Current | 0.1 mA @ 24VDC 0.1 mA @ 24VAC |
| Maximum Output Current | 2A |
| Maximum Inrush Current | 5A for 50ms |
| Maximum Leakage Current | 1 μ A (DC), 300 μ A (AC) due to RC snubber circuit |
| ON Voltage Drop | 0.2 V Max |
| Status Indicators | Logic Side, Green |
| Output Details | |
| Output Type | Standard |
| Location | Y0...Y15 |
| ON-OFF Response | <10ms |
| OFF-ON Response | <10ms |
| Maximum Switching Frequency | 10Hz |
| Relay Cycle Life | 5 million operations |
| Mechanical Endurance | 120,000 operations |
| Electrical Endurance | |
| Fuse Type | User-supplied external fuse |

BX-DM1E-36AR3 Wiring, Continued

Discrete Output Connection Options

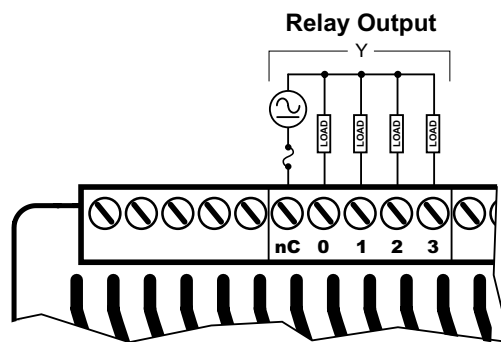

Discrete Standard Output Internal Circuitry

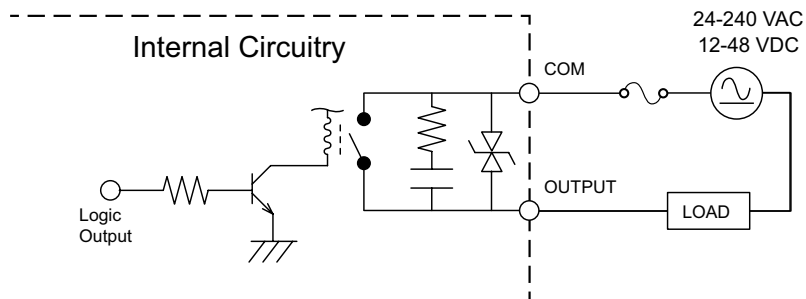

BX-DM1E-36AR3 Wiring, Continued

Analog Input Specifications

| Analog Input Specifications | |
|--|--|
| Inputs per Module | 4 |
| Commons | 1 |
| Input Voltage Range * | Software Selectable $\pm 10V$, $\pm 5V$, 0–10 V, 0–5 V |
| Input Current Range * | Software Selectable $\pm 20mA$, 4–20 mA |
| Resolution $\pm 10V$, $\pm 20mA$ $\pm 5V$ 0–5 V 4–20 mA 0–10 V | 16 bits (0–65535 counts) 15 bits (0–32767 counts) 14 bits (0–16383 counts) ~15 bits (6553–32767 counts) 15 bits (0–32767 counts) |
| Input Impedance Voltage Modes | 100k Ω |
| Absolute Maximum Input, Voltage Mode | $\pm 30V$ |
| Input Impedance Current Modes | 249 Ω |
| Absolute Maximum Input, Current Mode | $\pm 40mA$ sustained, $\pm 100mA$ for < 5s |
| Conversion Time | 1.2 ms |
| Input Stability | 0.02% of Full Hardware Range = 13 Counts |
| Full Scale Calibration Error | 0.05% of Full Hardware Range = 33 Counts |
| Offset Calibration Error | 0.01% of Full Hardware Range = 7 Counts |
| Accuracy vs Temperature Error | 0.05% of Full Hardware Range = 33 Counts |
| Maximum Linearity Error (End to End) | 0.1% of Full Hardware Range = 66 Counts |
| Maximum Inaccuracy | 0.2% of Full Hardware Range = 131 Counts |
| Fuse Type | User-supplied external fuse |

* *Software selectable per channel*

BX-DM1E-36AR3 Wiring, Continued

Analog Input Connection Options

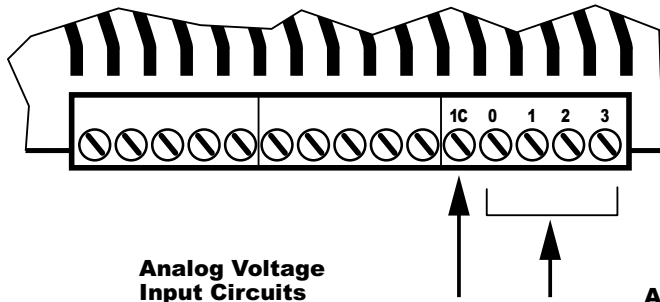

Analog Voltage Input Circuits

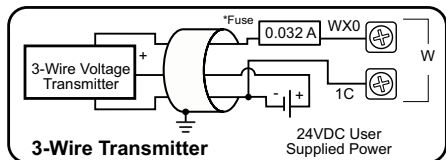
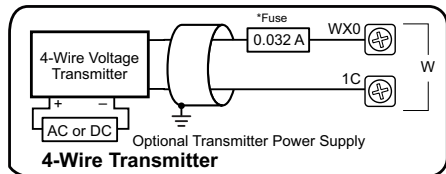

NOTE: Shield should be connected only at one end, to ground at the source device.

Analog Current Sinking Input Circuits

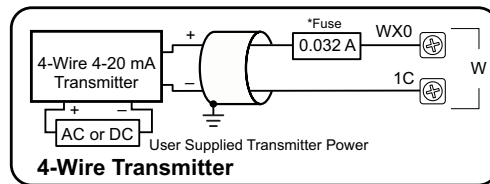
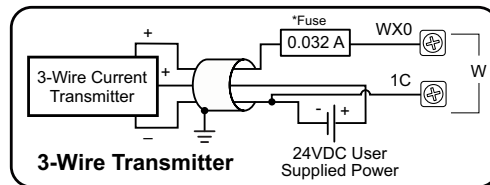
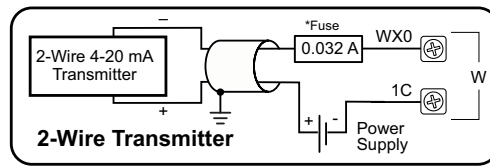

NOTE: Shield should be connected only at one end, to ground at the source device.



NOTE: An Edison S500-32-R 0.032A fast-acting fuse is recommended for all analog voltage inputs, analog outputs, and current loops.

BX-DM1E-36AR3 Wiring, Continued

Analog Output Specifications

| Analog Output Specifications | |
|--|--|
| Outputs per Module | 2 |
| Commons | 3 |
| Output Voltage Range * | Software Selectable $\pm 10V$, $\pm 5V$, $0-10 V$, $0-5 V$ |
| Output Current Range * | Software Selectable $\pm 20mA$, $4-20 mA$ |
| Resolution $\pm 10V$, $\pm 20mA$ $\pm 5V$ $0-5 V$ $4-20 mA$ $0-10 V$ | 16 bits (0–65535 counts) 15 bits (0–32767 counts) 14 bits (0–16383 counts) ~15 bits (6553–32767 counts) 15 bits (0–32767 counts) |
| Minimum Voltage Load Impedance | 1k Ω |
| Maximum Current Load Impedance | 500 Ω |
| Maximum Rating | Continuous Short Circuit Protected |
| Settling Time | < 1ms |
| Output Stability | 0.02% of Full Hardware Range = 13 Counts |
| Full Scale Calibration Error | 0.05% of Full Hardware Range = 33 Counts |
| Offset Calibration Error | 0.01% of Full Hardware Range = 7 Counts |
| Accuracy vs Temperature Error | 0.05% of Full Hardware Range = 33 Counts |
| Maximum Linearity Error (End to End) | 0.1% of Full Hardware Range = 66 Counts |
| Maximum Inaccuracy | 0.2% of Full Hardware Range = 131 Counts |
| Fuse Type | User-supplied external fuse |

* Software selectable per channel

Analog Output Connection Options

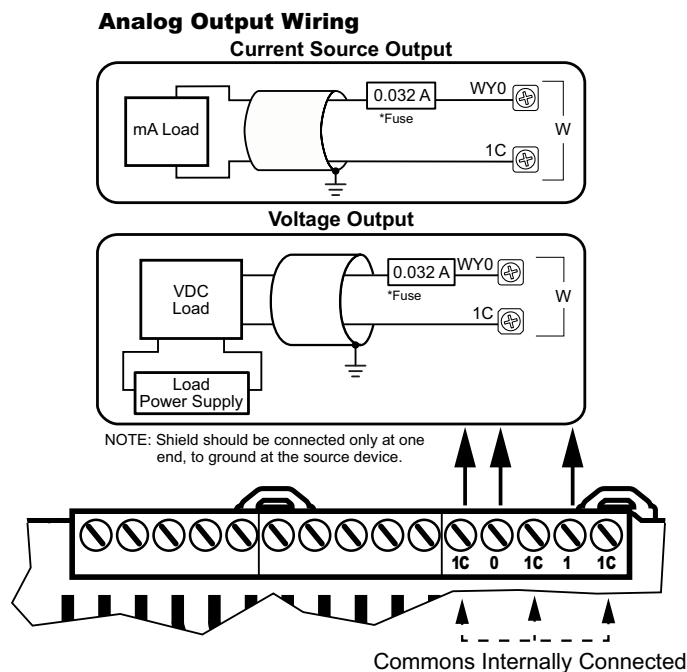

NOTE: An Edison S500-32-R 0.032A fast-acting fuse is recommended for all analog voltage inputs, analog outputs, and current loops.

Notes: