

HITACHI

SJ100 Series Inverter

Instruction Manual

- Single-phase Input 200V Class
- Three-phase Input 200V Class
- Three-phase Input 400V Class



Manual Number: NB585XD

**After reading this manual,
keep it handy for future reference.**

Hitachi Industrial Equipment Systems Co., Ltd.

Safety Messages

For the best results with the SJ100 Series inverter, carefully read this manual and all of the warning labels attached to the inverter before installing and operating it, and follow the instructions exactly. Keep this manual handy for quick reference.

Definitions and Symbols

A safety instruction (message) includes a “Safety Alert Symbol” and a signal word or phrase such as **WARNING** or **CAUTION**. Each signal word has the following meaning:



HIGH VOLTAGE: This symbol indicates high voltage. It calls your attention to items or operations that could be dangerous to you and other persons operation this equipment. Read the message and follow the instructions carefully.



WARNING: Indicates a potentially hazardous situation that, if not avoided, can result in serious injury or death.



CAUTION: Indicates a potentially hazardous situation that, if not avoided, can result in minor to moderate injury, or serious damage to the product. The situation described in the **CAUTION** may, if not avoided, lead to serious results. Important safety measures are described in **CAUTION** (as well as **WARNING**), so be sure to observe them.



Step 1: Indicates a step in a series of action steps required to accomplish a goal. The number of the step will be contained in the step symbol.



NOTE: Notes indicate an area or subject of special merit, emphasizing either the product’s capabilities or common errors in operation or maintenance.



TIP: Tips give a special instruction that can save time or provide other benefits while installing or using the product. The tip calls attention to an idea that may not be obvious to first-time users of the product.

Hazardous High Voltage



HIGH VOLTAGE: Motor control equipment and electronic controllers are connected to hazardous line voltages. When servicing drives and electronic controllers, there may be exposed components with housings or protrusions at or above line potential. Extreme care should be taken to protect against shock.

Stand on an insulating pad and make it a habit to use only one hand when checking components. Always work with another person in case an emergency occurs. Disconnect power before checking controllers or performing maintenance. Be sure equipment is properly grounded. Wear safety glasses whenever working on electronic controllers or rotating machinery.

General Precautions - Read These First!



WARNING: This equipment should be installed, adjusted, and serviced by qualified electrical maintenance personnel familiar with the construction and operation of the equipment and the hazards involved. Failure to observe this precaution could result in bodily injury.



WARNING: The user is responsible for ensuring that all driven machinery, drive train mechanism not supplied by Hitachi Industrial Equipment Systems Co., Ltd., and process line material are capable of safe operation at an applied frequency of 150% of the maximum selected frequency range to the AC motor. Failure to do so can result in destruction of equipment and injury to personnel should a single-point failure occur.



WARNING: For equipment protection, install a ground leakage type breaker with a fast response circuit capable of handling large currents. The ground fault protection circuit is not designed to protect against personal injury.



WARNING: HAZARD OF ELECTRICAL SHOCK. DISCONNECT INCOMING POWER BEFORE WORKING ON THIS CONTROL.



WARNING: Wait at least five (5) minutes after turning OFF the input power supply before performing maintenance or an inspection. Otherwise, there is the danger of electric shock.



CAUTION: These instructions should be read and clearly understood before working on SJ100 series equipment.



CAUTION: Proper grounds, disconnecting devices and other safety devices and their location are the responsibility of the user and are not provided by Hitachi Industrial Equipment Systems Co., Ltd.



CAUTION: Be sure to connect a motor thermal disconnect switch or overload device to the SJ100 series controller to assure that the inverter will shut down in the event of an overload or an overheated motor.



HIGH VOLTAGE: Dangerous voltage exists until power light is OFF. Wait at least five (5) minutes after input power is disconnected before performing maintenance.



WARNING: This equipment has high leakage current and must be permanently (fixed) hard-wired to earth ground via two independent cables.



WARNING: Rotating shafts and above-ground electrical potentials can be hazardous. Therefore, it is strongly recommended that all electrical work conform to the National Electrical Codes and local regulations. Installation, alignment and maintenance should be performed only by qualified personnel.

Factory-recommended test procedures included in the instruction manual should be followed. Always disconnect electrical power before working on the unit.



CAUTION:

- a) Class I motor must be connected to earth ground via low resistive path ($< 0.1\Omega$)
- b) Any motor used must be of a suitable rating.
- c) Motors may have hazardous moving parts. In this event suitable protection must be provided.



CAUTION: Alarm connection may contain hazardous live voltage even when inverter is disconnected. When removing the front cover for maintenance or inspection, confirm that incoming power for alarm connection is completely disconnected.



CAUTION: Hazardous (main) terminals for any interconnection (motor, contact breaker, filter, etc.) must be inaccessible in the final installation.



CAUTION: This equipment should be installed in IP54 or equivalent (see EN60529) enclosure. The end application must be in accordance with BS EN60204-1. Refer to the section [“Choosing a Mounting Location” on page 2-7](#). The diagram dimensions are to be suitably amended for your application.



CAUTION: Connection to field wiring terminals must be reliably fixed having two independent means of mechanical support. Use a termination with cable support (figure below), or strain relief, cable clamp, etc.

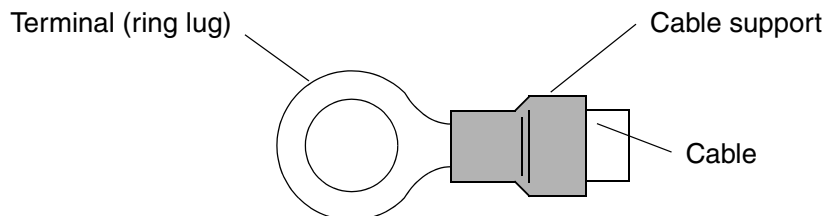

CAUTION: A double-pole disconnection device must be fitted to the incoming main power supply close to the inverter. Additionally, a protection device meeting IEC947-1/ IEC947-3 must be fitted at this point (protection device data shown in [“Determining Wire and Fuse Sizes” on page 2-14](#)).



NOTE: The above instructions, together with any other requirements highlighted in this manual, must be followed for continued LVD (European Low Voltage Directive) compliance.

Index to Warnings and Cautions in This Manual

Installation - Cautions for Mounting Procedures



CAUTION: The inverter is shipped with a plastic cover over the top vent grill. REMOVE this cover after the installation is complete. Operation with this cover in place will not allow proper cooling, and damage to the inverter may result. [2-6](#)



CAUTION: Be sure to install the unit on flame-resistant material such as a steel plate. Otherwise, there is the danger of fire. [2-7](#)



CAUTION: Be sure not to place any flammable materials near the inverter. Otherwise, there is the danger of fire. [2-7](#)



CAUTION: Be sure not to let the foreign matter enter vent openings in the inverter housing, such as wire clippings, spatter from welding, metal shavings, dust, etc. Otherwise, there is the danger of fire. [2-7](#)



CAUTION: Be sure to install the inverter in a place that can bear the weight according to the specifications in the text (Chapter 1, Specifications Tables). Otherwise, it may fall and cause injury to personnel. [2-7](#)



CAUTION: Be sure to install the unit on a perpendicular wall that is not subject to vibration. Otherwise, it may fall and cause injury to personnel. [2-7](#)



CAUTION: Be sure not to install or operate an inverter that is damaged or has missing parts. Otherwise, it may cause injury to personnel. [2-7](#)



CAUTION: Be sure to install the inverter in a well-ventilated room that does not have direct exposure to sunlight, a tendency for high temperature, high humidity or dew condensation, high levels of dust, corrosive gas, explosive gas, inflammable gas, grinding-fluid mist, salt damage, etc. Otherwise, there is the danger of fire. [2-7](#)



CAUTION: Be sure to maintain the specified clearance area around the inverter and to provide adequate ventilation. Otherwise, the inverter may overheat and cause equipment damage or fire. [2-8](#)

Wiring - Warnings for Electrical Practices and Wire Specifications



WARNING: "Use 60/75°C Cu wire only" or equivalent. [2-13](#)





WARNING: "Open Type Equipment." [2-13](#)





WARNING: "Suitable for use on a circuit capable of delivering not more than 5,000 rms symmetrical amperes, 240 V maximum." For models with suffix N or L. [2-13](#)

- 

WARNING: “Suitable for use on a circuit capable of delivering not more than 5,000 rms symmetrical amperes, 480 V maximum.” For models with suffix H. [2-13](#)
- 

HIGH VOLTAGE: Be sure to ground the unit. Otherwise, there is a danger of electric shock and/or fire. [2-13](#)
- 

HIGH VOLTAGE: Wiring work shall be carried out only by qualified personnel. Otherwise, there is a danger of electric shock and/or fire. [2-13](#)
- 

HIGH VOLTAGE: Implement wiring after checking that the power supply is OFF. Otherwise, you may incur electric shock and/or fire. [2-13](#)
- 

HIGH VOLTAGE: Do not connect wiring to an inverter or operate an inverter that is not mounted according the instructions given in this manual. Otherwise, there is a danger of electric shock and/or injury to personnel. [2-13](#)
- 

WARNING: Make sure the input power to the inverter is OFF. If the drive has been powered, leave it OFF for five minutes before continuing. [2-19](#)

Wiring - Cautions for Electrical Practices

- 

CAUTION: Fasten the screws with the specified fastening torque in the table below. Check for any loosening of screws. Otherwise, there is the danger of fire. [2-15](#)
- 

CAUTION: Be sure that the input voltage matches the inverter specifications: • Single/Three phase 200 to 240 V 50/60 Hz (up to 2.2kW) • Three phase 200 to 230V 50/60Hz (above 2.2kW) • Three phase 380 to 460 V 50/60Hz [2-16](#)
- 

CAUTION: Be sure not to power a three-phase-only inverter with single phase power. Otherwise, there is the possibility of damage to the inverter and the danger of fire. [2-16](#)
- 

CAUTION: Be sure not to connect an AC power supply to the output terminals. Otherwise, there is the possibility of damage to the inverter and the danger of injury and/or fire. [2-17](#)

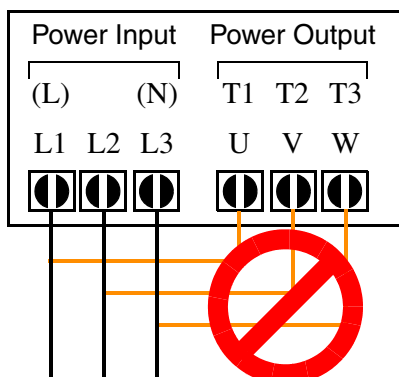

NOTE:

- L, N: Single-phase 200 to 240V 50/60 Hz
- L1, L2, L3: Three-phase 200 to 240V 50/60 Hz
- Three-phase 380 to 460V 50/60 Hz



CAUTION: Remarks for using ground fault interrupter breakers in the main power supply: Adjustable frequency inverters with CE-filters (RFI-filter) and shielded (screened) motor cables have a higher leakage current toward Earth GND. Especially at the moment of switching ON this can cause an inadvertent trip of ground fault interrupters. Because of the rectifier on the input side of the inverter there is the possibility to stall the switch-off function through small amounts of DC current. Please observe the following: • Use only short time-invariant and pulse current-sensitive ground fault interrupters with higher trigger current. • Other components should be secured with separate ground fault interrupters. • Ground fault interrupters in the power input wiring of an inverter are not an absolute protection against electric shock.

..... [2-17](#)



CAUTION: Be sure to install a fuse in each phase of the main power supply to the inverter. Otherwise, there is the danger of fire.

..... [2-17](#)



CAUTION: For motor leads, ground fault interrupter breakers and electromagnetic contactors, be sure to size these components properly (each must have the capacity for rated current and voltage). Otherwise, there is the danger of fire.

..... [2-17](#)

Powerup Test Caution Messages



CAUTION: The heat sink fins will have a high temperature. Be careful not to touch them. Otherwise, there is the danger of getting burned.

..... [2-20](#)



CAUTION: The operation of the inverter can be easily changed from low speed to high speed. Be sure to check the capability and limitations of the motor and machine before operating the inverter. Otherwise, there is the danger of injury.

..... [2-20](#)



CAUTION: If you operate a motor at a frequency higher than the inverter standard default setting (50Hz/60Hz), be sure to check the motor and machine specifications with the respective manufacturer. Only operate the motor at elevated frequencies after getting their approval. Otherwise, there is the danger of equipment damage and/or injury.

.... [2-20](#),

..... [2-24](#)



CAUTION: Check the following before and during the powerup test. Otherwise, there is the danger of equipment damage. • Is the shorting bar between the [+1] and [+] terminals installed? DO NOT power or operate the inverter if the jumper is removed. • Is the direction of the motor rotation correct? • Did the inverter trip during acceleration or deceleration? • Were the rpm and frequency meter readings as expected? • Were there any abnormal motor vibrations or noise?

..... [2-20](#)

Warnings for Configuring Drive Parameters



WARNING: When parameter B_12, level of electronic thermal setting, is set to device FLA rating (Full Load Ampere nameplate rating), the device provides solid state motor overload protection at 115% of device FLA or equivalent. Parameter B_12, level of electronic thermal setting, is a variable parameter. [3-26](#)

Cautions for Configuring Drive Parameters



CAUTION: Be careful to avoid specifying a braking time that is long enough to cause motor overheating. If you use DC braking, we recommend using a motor with a built-in thermistor, and wiring it to the inverter's thermistor input (see "Thermistor Thermal Protection" on page 4-22). Also refer to the motor manufacturer's specifications for duty-cycle recommendations during DC braking. [3-16](#)

Warnings for Operations and Monitoring



WARNING: Be sure to turn ON the input power supply only after closing the front case. While the inverter is energized, be sure not to open the front case. Otherwise, there is the danger of electric shock. [4-3](#)



WARNING: Be sure not to operate electrical equipment with wet hands. Otherwise, there is the danger of electric shock. [4-3](#)



WARNING: While the inverter is energized, be sure not to touch the inverter terminals even when the motor is stopped. Otherwise, there is the danger of electric shock. [4-3](#)



WARNING: If the Retry Mode is selected, the motor may suddenly restart after a trip stop. Be sure to stop the inverter before approaching the machine (be sure to design the machine so that safety for personnel is secure even if it restarts.) Otherwise, it may cause injury to personnel. [4-3](#)









WARNING: If the power supply is cut OFF for a short period of time, the inverter may restart operation after the power supply recovers if the Run command is active. If a restart may pose danger to personnel, so be sure to use a lock-out circuit so that it will not restart after power recovery. Otherwise, it may cause injury to personnel. [4-3](#)







WARNING: The Stop Key is effective only when the Stop function is enabled. Be sure to enable the Stop Key separately from the emergency stop. Otherwise, it may cause injury to personnel. [4-3](#)



WARNING: During a trip event, if the alarm reset is applied and the Run command is present, the inverter will automatically restart. Be sure to apply the alarm reset only after verifying the Run command is OFF. Otherwise, it may cause injury to personnel. [4-3](#)

-  WARNING: Be sure not to touch the inside of the energized inverter or to put any conductive object into it. Otherwise, there is a danger of electric shock and/or fire. [4-3](#)
-  WARNING: If power is turned ON when the Run command is already active, the motor will automatically start and injury may result. Before turning ON the power, confirm that the RUN command is not present. [4-3](#)
-  WARNING: When the Stop key function is disabled, pressing the Stop key does not stop the inverter, nor will it reset a trip alarm. [4-3](#)
-  WARNING: Be sure to provide a separate, hard-wired emergency stop switch when the application warrants it. [4-3](#)
-  WARNING: If the power is turned ON and the Run command is already active, the motor starts rotation and is dangerous! Before turning power ON, confirm that the Run command is not active. [4-9](#)
-  WARNING: After the Reset command is given and the alarm reset occurs, the motor will restart suddenly if the Run command is already active. Be sure to set the alarm reset after verifying that the Run command is OFF to prevent injury to personnel. [4-21](#)
-  WARNING: You may need to disconnect the load from the motor before performing auto-tuning. The inverter runs the motor forward and backward for several seconds without regard to load movement limits. [4-35](#)

Cautions for Operations and Monitoring

-  CAUTION: The heat sink fins will have a high temperature. Be careful not to touch them. Otherwise, there is the danger of getting burned. [4-2](#)
-  CAUTION: The operation of the inverter can be easily changed from low speed to high speed. Be sure check the capability and limitations of the motor and machine before operating the inverter. Otherwise, it may cause injury to personnel. [4-2](#)
-  CAUTION: If you operate a motor at a frequency higher than the inverter standard default setting (50Hz/60Hz), be sure to check the motor and machine specifications with the respective manufacturer. Only operate the motor at elevated frequencies after getting their approval. Otherwise, there is the danger of equipment damage. [4-2](#)
-  CAUTION: It is possible to damage the inverter or other devices if your application exceeds the maximum current or voltage characteristics of a connection point. [4-4](#)

Warnings and Cautions for Troubleshooting and Maintenance



WARNING: Wait at least five (5) minutes after turning OFF the input power supply before performing maintenance or an inspection. Otherwise, there is the danger of electric shock.

..... [6-2](#)



WARNING: Make sure that only qualified personnel will perform maintenance, inspection, and part replacement. Before starting to work, remove any metallic objects from your person (wristwatch, bracelet, etc.). Be sure to use tools with insulated handles. Otherwise, there is a danger of electric shock and/or injury to personnel.

..... [6-2](#)



WARNING: Never remove connectors by pulling on its wire leads (wires for cooling fan and logic P.C.board). Otherwise, there is a danger of fire due to wire breakage and/or injury to personnel.

..... [6-2](#)



CAUTION: Do not connect the megger to any control circuit terminals such as intelligent I/O, analog terminals, etc. Doing so could cause damage to the inverter.

.... [6-10](#)



CAUTION: Never test the withstand voltage (HIPOT) on the inverter. The inverter has a surge protector between the main circuit terminals above and the chassis ground.

.... [6-10](#)



HIGH VOLTAGE: Be careful not to touch wiring or connector terminals when working with the inverters and taking measurements. Be sure to place the measurement circuitry components above in an insulated housing before using them.

.... [6-14](#)

General Warnings and Cautions



WARNING: Never modify the unit. Otherwise, there is a danger of electric shock and/or injury.



CAUTION: Withstand voltage tests and insulation resistance tests (HIPOT) are executed before the units are shipped, so there is no need to conduct these tests before operation.



CAUTION: Do not attach or remove wiring or connectors when power is applied. Also, do not check signals during operation.



CAUTION: Be sure to connect the grounding terminal to earth ground.



CAUTION: When inspecting the unit, be sure to wait five minutes after tuning OFF the power supply before opening the cover.



CAUTION: Do not stop operation by switching OFF electromagnetic contactors on the primary or secondary sides of the inverter.

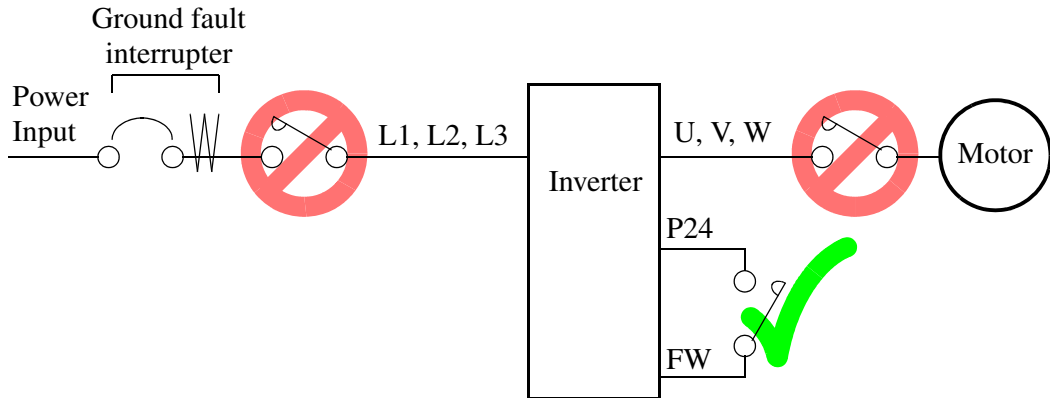

When there has been a sudden power failure while an operation instruction is active, then the unit may restart operation automatically after the power failure has ended. If there is a possibility that such an occurrence may harm humans, then install an electromagnetic contactor (Mgo) on the power supply side, so that the circuit does not allow automatic restarting after the power supply recovers. If the optional remote operator is used and the retry function has been selected, this will also cause automatic restarting when a Run command is active. So, please be careful.



CAUTION: Do not insert leading power factor capacitors or surge absorbers between the output terminals of the inverter and motor.

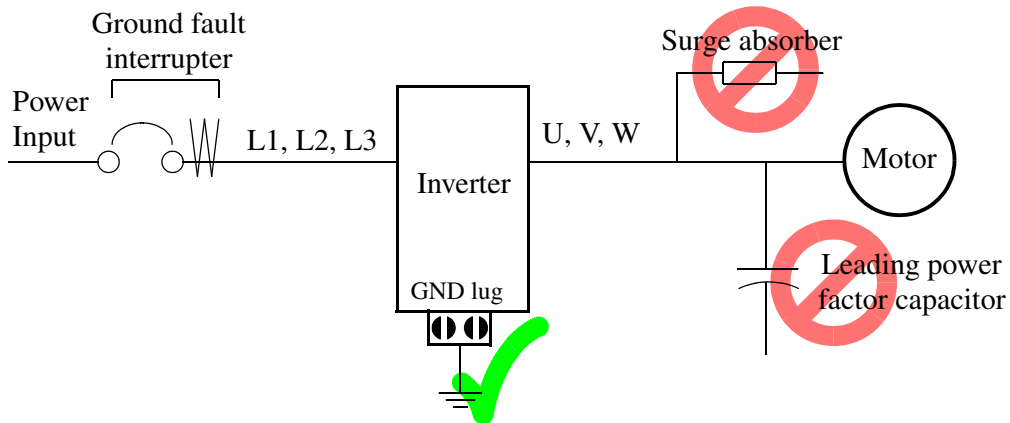

CAUTION: MOTOR TERMINAL SURGE VOLTAGE SUPPRESSION FILTER (For the 400 V CLASS)

In a system using an inverter with the voltage control PWM system, a voltage surge caused by the cable constants such as the cable length (especially when the distance between the motor and inverter is 10 m or more) and cabling method may occur at the motor terminals. A dedicated filter of the 400 V class for suppressing this voltage surge is available. Be sure to install a filter in this situation.



CAUTION: SUPPRESSION FOR NOISE INTERFERENCE FROM INVERTER

The inverter uses many semiconductor switching elements such as transistors and IGBTs. Thus, a radio receiver or measuring instrument located near the inverter is susceptible to noise interference.

To protect the instruments from erroneous operation due to noise interference, they should be used well away from the inverter. It is also effective to shield the whole inverter structure.

The addition of an EMI filter on the input side of the inverter also reduces the effect of noise from the commercial power line on external devices.

Note that the external dispersion of noise from the power line can be minimized by connecting an EMI filter on the primary side of inverter.

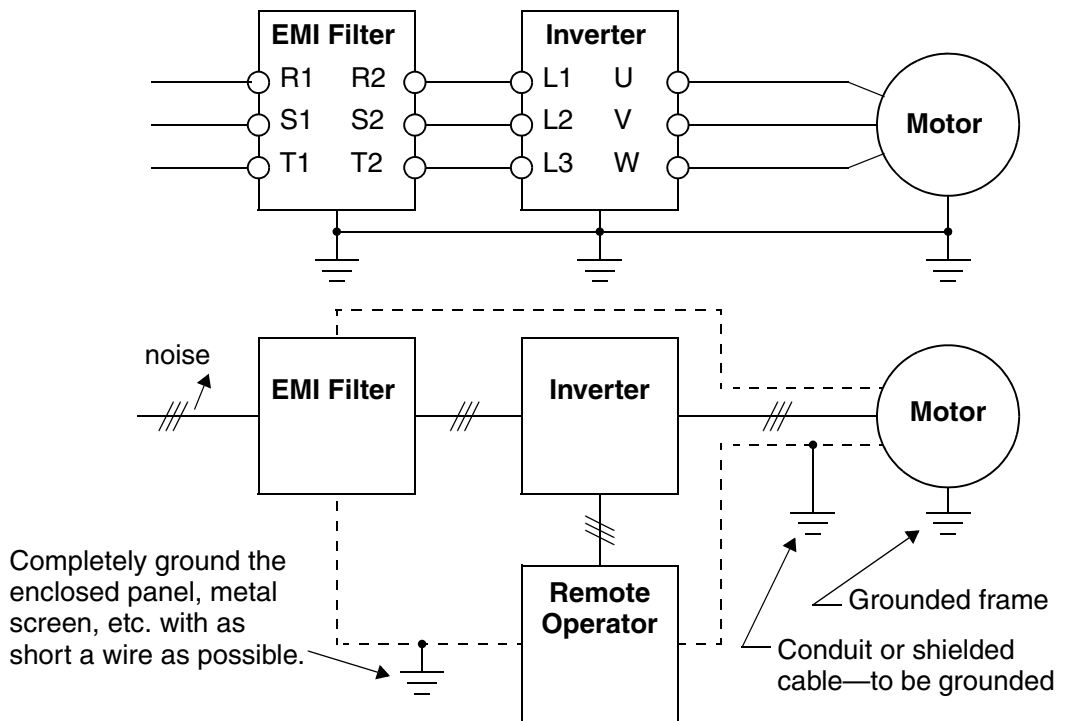

CAUTION: EFFECTS OF POWER DISTRIBUTION SYSTEM ON INVERTER

In the cases below involving a general-purpose inverter, a large peak current can flow on the power supply side, sometimes destroying the converter module:

1. The unbalance factor of the power supply is 3% or higher.
2. The power supply capacity is at least 10 times greater than the inverter capacity (or the power supply capacity is 500 kVA or more).
3. Abrupt power supply changes are expected, due to conditions such as:
 - a. Several inverters are interconnected with a short bus.
 - b. A thyristor converter and an inverter are interconnected with a short bus.
 - c. An installed phase advance capacitor opens and closes.

Where these conditions exist or when the connected equipment must be highly reliable, you **MUST** install an input-side AC reactor of 3% (at a voltage drop at rated current) with respect to the supply voltage on the power supply side. Also, where the effects of an indirect lightning strike are possible, install a lightning conductor.



CAUTION: When the EEPROM error E08 occurs, be sure to confirm the setting values again.



CAUTION: When using *normally closed* active state settings (C_11 to C_16) for externally commanded Forward or Reverse terminals [FW] or [RV], the inverter may start automatically *when the external system is powered OFF or disconnected from the inverter!* So, do not use normally closed active state settings for Forward or Reverse terminals [FW] or [RV] unless your system design protects against unintended motor operation.



CAUTION: In all the illustrations in this manual, covers and safety devices are occasionally removed to describe the details. While operating the product, make sure that the covers and safety devices are placed as they were specified originally and operate it according to the instruction manual.

UL[®] Cautions, Warnings, and Instructions

Wiring Warnings for Electrical Practices and Wire Sizes

The Cautions, Warnings, and instructions in this section summarize the procedures necessary to ensure an inverter installation complies with Underwriters Laboratories[®] guidelines.



WARNING: “Use 60/75°C Cu wire only” or equivalent.



WARNING: “Open Type Equipment.”



WARNING: “Suitable for use on a circuit capable of delivering not more than 5,000 rms symmetrical amperes, 240 V maximum.” For models with suffix N or L.



WARNING: “Suitable for use on a circuit capable of delivering not more than 5,000 rms symmetrical amperes, 480 V maximum.” For models with suffix H.

Terminal Tightening Torque and Wire Size

The wire size range and tightening torque for field wiring terminals are presented in the table below.

Input Voltage	Motor Output		Inverter Model	Wiring Size Range (AWG)	Torque	
	kW	HP			ft-lbs	(N-m)
200V	0.2	1/4	SJ100-002NFE/NFU	16	0.6	0.8
	0.4	1/2	SJ100-004NFE/NFU			
	0.55	3/4	SJ100-005NFE			
	0.75	1	SJ100-007NFE/NFU	14	0.9	1.2
	1.1	1 1/2	SJ100-011NFE			
	1.5	2	SJ100-015NFE/NFU			
	2.2	3	SJ100-022NFE/NFU			
	3.7	5	SJ100-037LFU	12	1.5	2.0
	5.5	7 1/2	SJ100-055LFU	10		
	7.5	10	SJ100-075LFU	8		
400V	0.4	1/2	SJ100-004HFE/HFU	16	0.9	1.2
	0.75	1	SJ100-007HFE/HFU			
	1.5	2	SJ100-015HFE/HFU			
	2.2	3	SJ100-022HFE/HFU			
	3.0	4	SJ100-030HFE	14	1.5	2.0
	4.0	5	SJ100-040HFE/HFU			
	5.5	7 1/2	SJ100-055HFE/HFU	12		
	7.5	10	SJ100-075HFE/HFU			

Wire Connectors



WARNING: Field wiring connections must be made by a UL Listed and CSA Certified ring lug terminal connector sized for the wire gauge being used. The connector must be fixed using the crimping tool specified by the connector manufacturer.

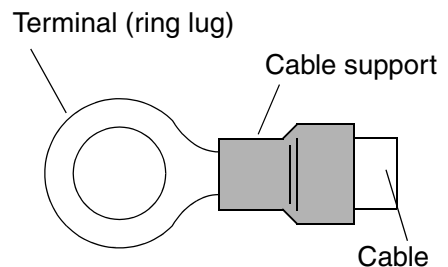

Circuit Breaker and Fuse Sizes

The inverter's connections to input power must include UL Listed inverse time circuit breakers with 600V rating, or UL Listed fuses as shown in the table below.

Input Voltage	Motor Output		Inverter Model	Fuse (A) (UL-rated, class J, 600V)
	kW	HP		
200V	0.2	1/4	SJ100-002NFE/NFU	10
	0.4	1/2	SJ100-004NFE/NFU	10
	0.55	3/4	SJ100-005NFE	10
	0.75	1	SJ100-007NFE/NFU	15
	1.1	1 1/2	SJ100-011NFE	15
	1.5	2	SJ100-015NFE/NFU	20 (single ph.) 15 (three ph.)
	2.2	3	SJ100-022NFE/NFU	30 (single ph.) 20 (three ph.)
	3.7	5	SJ100-037LFU	30
	5.5	7 1/2	SJ100-055LFU	40
	7.5	10	SJ100-075LFU	50
400V	0.4	1/2	SJ100-004HFE/HFU	3
	0.75	1	SJ100-007HFE/HFU	6
	1.5	2	SJ100-015HFE/HFU	10
	2.2	3	SJ100-022HFE/HFU	10
	3.0	4	SJ100-030HFE	15
	4.0	5	SJ100-040HFE/HFU	15
	5.5	7 1/2	SJ100-055HFE/HFU	20
	7.5	10	SJ100-075HFE/HFU	25

Motor Overload Protection

Hitachi SJ100 inverters provide solid state motor overload protection, which depends on the proper setting of the following parameters:

- B_12 “electronic overload protection”
- B212 “electronic overload protection, 2nd motor”

Set the rated current [Amperes] of the motor(s) with the above parameters. The setting range is 0.5 * rated current to 1.2 * rated current.



WARNING: When two or more motors are connected to the inverter, they cannot be protected by the electronic overload protection. Install an external thermal relay on each motor.

Table of Contents

Safety Messages

Hazardous High Voltage	i
General Precautions - Read These First!	ii
Index to Warnings and Cautions in This Manual	iv
General Warnings and Cautions	ix
UL® Cautions, Warnings, and Instructions	xii

Table of Contents

Revisions	xvii
Contact Information	xviii

Chapter 1: Getting Started

Introduction	1-2
SJ100 Inverter Specifications	1-5
Introduction to Variable-Frequency Drives	1-17
Frequently Asked Questions	1-22

Chapter 2: Inverter Mounting and Installation

Orientation to Inverter Features	2-2
Basic System Description	2-5
Step-by-Step Basic Installation	2-6
Powerup Test	2-19
Using the Front Panel Keypad	2-21

Chapter 3: Configuring Drive Parameters

Choosing a Programming Device	3-2
Using Keypad Devices	3-3
“D” Group: Monitoring Functions	3-6
“F” Group: Main Profile Parameters	3-8
“A” Group: Standard Functions	3-9
“B” Group: Fine Tuning Functions	3-24
“C” Group: Intelligent Terminal Functions	3-34
“H” Group: Motor Constants Functions	3-43

Chapter 4: Operations and Monitoring

<u>Introduction</u>	4-2
<u>Connecting to PLCs and Other Devices</u>	4-4
<u>Example Wiring Diagram</u>	4-5
<u>Using Intelligent Input Terminals</u>	4-8
<u>Using Intelligent Output Terminals</u>	4-24
<u>Analog Input Operation</u>	4-32
<u>Analog and Digital Monitor Output</u>	4-33
<u>Auto-tuning for Sensorless Vector Control</u>	4-35
<u>PID Loop Operation</u>	4-39
<u>Configuring the Inverter for Multiple Motors</u>	4-40

Chapter 5: Inverter System Accessories

<u>Introduction</u>	5-2
<u>Component Descriptions</u>	5-3
<u>Dynamic Braking</u>	5-5

Chapter 6: Troubleshooting and Maintenance

<u>Troubleshooting</u>	6-2
<u>Monitoring Trip Events, History, & Conditions</u>	6-5
<u>Restoring Factory Default Settings</u>	6-8
<u>Maintenance and Inspection</u>	6-9
<u>Warranty</u>	6-16

Appendix A: Glossary and Bibliography

<u>Glossary</u>	A-2
<u>Bibliography</u>	A-8

Appendix B: Drive Parameter Settings Tables

<u>Introduction</u>	B-2
<u>Parameter Settings for Keypad Entry</u>	B-2

Appendix C: CE–EMC Installation Guidelines

<u>CE–EMC Installation Guidelines</u>	C-2
<u>Hitachi EMC Recommendations</u>	C-6

Index

Revisions

Revision History Table

No.	Revision Comments	Date of Issue	Operation Manual No.
	Initial release of manual NB585X	April 1999	NB585X
1	Revision A Added 7.5 and 10 HP models to tables and drawings in Chapters 1 and 2, made minor typographical or technical corrections throughout manual	May 1999	NB585XA
2	Revision B Pages 1-4, 5 – Specs tables: corrected weights (lbs), added row for input current, corrected dynamic braking % torque Page 2-11 – Added note about fans at bottom of page Page 2-15 – Added torque specs for 7.5 and 10 HP models Page 3-36 – Added larger motor sizes to H_03/H203 motor capacity settings in table Page 3-41 – Added note about SLV operation at top of page Pages 4-30, 31 – Changed text in notes for Steps 1, 2, and 10 in table to clarify auto-tuning procedure Pages 4-31, 32 – Added auto-tuning notes at bottom of 4-31 and new page 4-32 about motor parameters, frame size, etc. Page 5-5 – Added braking resistor specs for 7.5 and 10 HP models	August 1999	NB585XB
3	Revision C Updated company name on cover, contact page, and nameplate photo Updated text, figures, and tables throughout manual per technical corrections or usability improvements Pages xii to xiv – Added UL Instructions Page xviii – Contact page update Pages 1-5 to 1-8 – Added watt loss, efficiency data to tables Pages 1-10 to 1-15 – Added derating graphs Page 2-16 – Added power terminal diagrams Page 4-5 – Added system wiring diagram Page 4-7 – Added terminal index listing Page 4-8 – Added input terminal wiring diagrams Page 4-24 – Added output terminal wiring diagrams Pages 5-5 to 5-10 – Added braking tables and figures Page 6-10 – Added megger test procedure and figure Page 6-15 – Added IGBT test method, figure, and table Pages C-1 to C-6 – Added appendix on CE-EMC Removed DOP+ info from Ch3 and Appendix B	May 2002	NB585XC
4	Revision D Minor corrections throughout	Nov. 2002	NB585XD

Contact Information

Hitachi America, Ltd.
Power and Industrial Division
50 Prospect Avenue
Tarrytown, NY 10591
U.S.A.
Phone: +1-914-631-0600
Fax: +1-914-631-3672

Hitachi Australia Ltd.
Level 3, 82 Waterloo Road
North Ryde, N.S.W. 2113
Australia
Phone: +61-2-9888-4100
Fax: +61-2-9888-4188

Hitachi Europe GmbH
Am Seestern 18
D-40547 Düsseldorf
Germany
Phone: +49-211-5283-0
Fax: +49-211-5283-649

Hitachi Industrial Equipment Systems Co, Ltd.
International Sales Department
WBG MARIVE WEST 16F
6, Nakase 2-chome
Mihama-ku, Chiba-shi,
Chiba 261-7116 Japan
Phone: +81-43-390-3516
Fax: +81-43-390-3810

Hitachi Asia Ltd.
16 Collyer Quay
#20-00 Hitachi Tower, Singapore 049318
Singapore
Phone: +65-538-6511
Fax: +65-538-9011

Hitachi Industrial Equipment Systems Co, Ltd.
Narashino Division
1-1, Higashi-Narashino 7-chome
Narashino-shi, Chiba 275-8611
Japan
Phone: +81-47-474-9921
Fax: +81-47-476-9517

Hitachi Asia (Hong Kong) Ltd.
7th Floor, North Tower
World Finance Centre, Harbour City
Canton Road, Tsimshatsui, Kowloon
Hong Kong
Phone: +852-2735-9218
Fax: +852-2735-6793



NOTE: To receive technical support for the Hitachi inverter you purchased, contact the Hitachi inverter dealer from whom you purchased the unit, or the sales office or factory contact listed above. Please be prepared to provide the following inverter nameplate information:

1. Model
2. Date of purchase
3. Manufacturing number (MFG No.)
4. Symptoms of any inverter problem

If any inverter nameplate information is illegible, please provide your Hitachi contact with any other legible nameplate items. To reduce unpredictable downtime, we recommend that you stock a spare inverter.

Getting Started



1

In This Chapter...	page
— Introduction	2
— SJ100 Inverter Specifications	5
— Introduction to Variable-Frequency Drives	17
— Frequently Asked Questions	22

Introduction

Main Features

Congratulations on your purchase of an SJ100 Series Hitachi inverter! This inverter drive features state-of-the-art circuitry and components to provide high performance. The housing footprint is exceptionally small, given the size of the corresponding motor. The Hitachi SJ100 product line includes more than a dozen inverter models to cover motor sizes from 1/4 horsepower to 10 horsepower, in either 230 VAC or 460 VAC power input versions. The main features are:

- 200V and 400V Class inverters
- UL or CE version available
- Sensorless vector control
- Regenerative braking circuit
- Convenient keypad for parameter settings
- Built-in RS-422 communications interface to allow configuration from a PC and for field bus external modules.
- Sixteen programmable speed levels
- Motor constants are programmable, or may be set via auto-tuning
- PID control adjusts motor speed automatically to maintain a process variable value

The design in Hitachi inverters overcomes many of the traditional trade-offs between speed, torque and efficiency. The performance characteristics are:

- High starting torque of 200% rating or greater
- Continuous operation at 100% torque within a 1:10 speed range (6/60 Hz / 5/50 Hz) without motor derating
- Fan has ON/OFF selection to provide longer life for cooling fan (on models with fan)



Model SJ100-004NFU

A full line of accessories from Hitachi is available to complete your motor application. These include:

- Digital remote operator keypad
- Braking resistors (shown at right)
- Radio noise filters
- CE compliance filters
- DIN rail mounting adapter (35mm rail size)



Braking Resistor

Operator Interface Options

The optional SRW-0EX digital operator / copy unit is shown to the right. It has the additional capability of reading (uploading) the parameter settings in the inverter into its memory. Then you can connect the copy unit on another inverter and write (download) the parameter settings into that inverter. OEMs will find this unit particularly useful, as one can use a single copy unit to transfer parameter settings from one inverter to many.

Other digital operator interfaces may be available from your Hitachi distributor for particular industries or international markets. Contact your Hitachi distributor for further details.



Digital Operator / Copy Unit

Inverter Specifications Label

The Hitachi SJ100 inverters have product labels located on the right side of the housing, as pictured below. Be sure to verify that the specifications on the labels match your power source, motor, and application safety requirements.

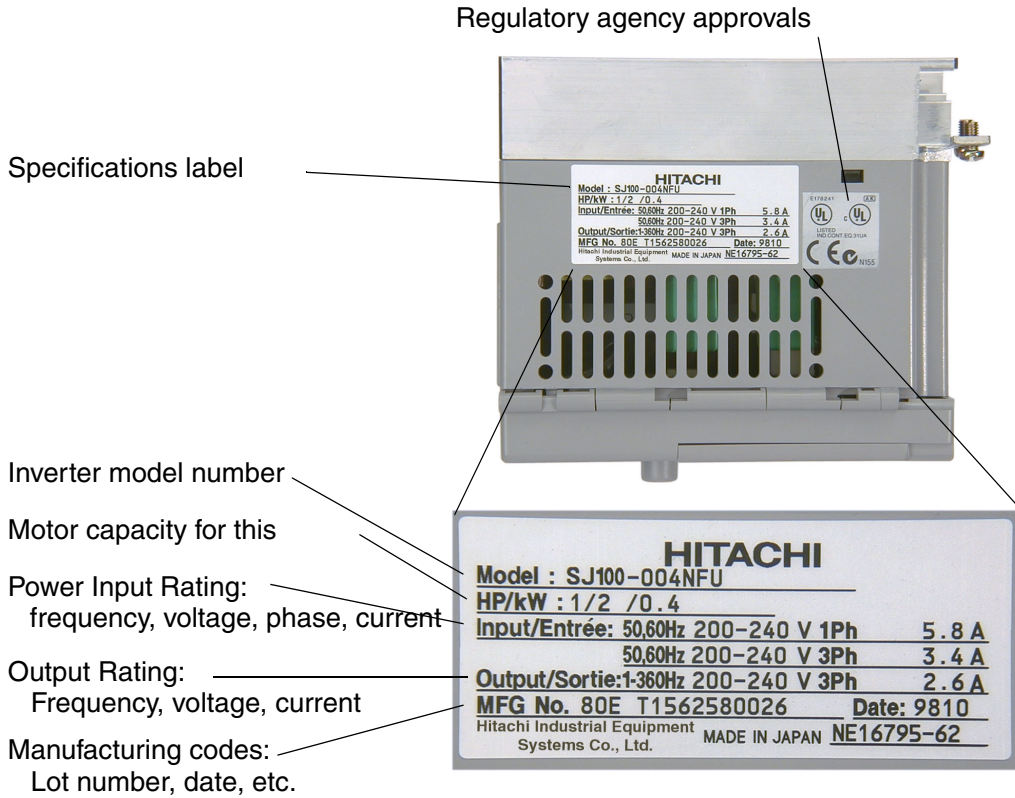

Model Number Convention

The model number for a specific inverter contains useful information about its operating characteristics. Refer to the model number legend below:

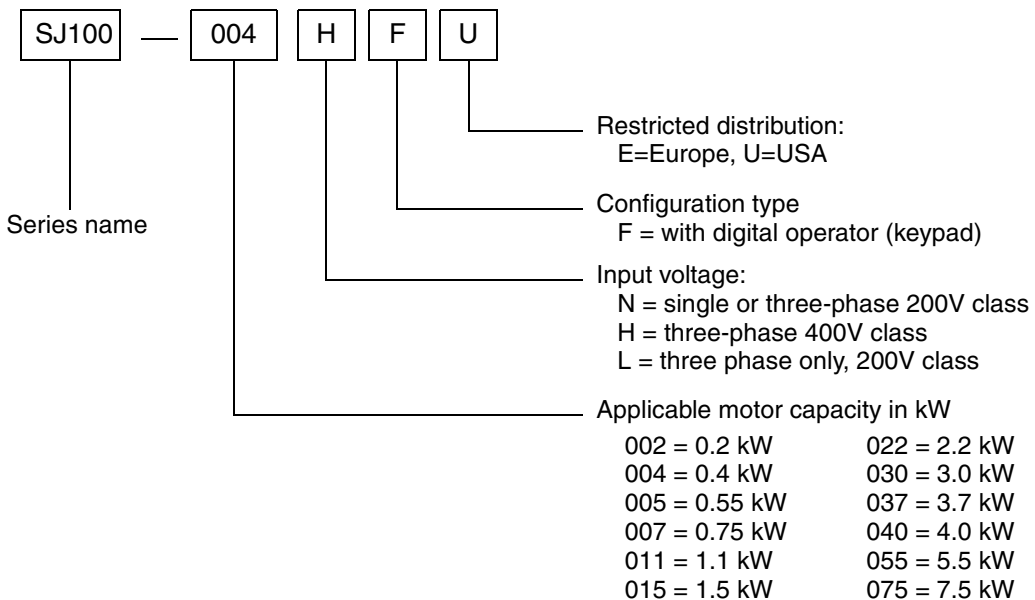

SJ100 Inverter Specifications

Model-specific tables for 200V and 400V class inverters

The following tables are specific to SJ100 inverters for the 200V and 400V class model groups. Note that [“General Specifications” on page 1-9](#) apply to both voltage class groups. Footnotes for all specifications tables follow the table below.

Item		200V Class Specifications				
SJ100 inverters, 200V models	CE version	002NFE	004NFE	005NFE	007NFE	011NFE
	UL version	002NFU	004NFU	—	007NFU	—
Applicable motor size *2	kW	0.2	0.4	0.55	0.75	1.1
	HP	1/4	1/2	3/4	1	1.5
Rated capacity (kVA) *12	230V	0.6	1.0	1.1	1.5	1.9
	240V	0.6	1.0	1.2	1.6	2.0
Rated input voltage		1-phase: 200 to 240V +5/-10%, 50/60 Hz \pm 5%, 3-phase: 200 to 240V +5/-10%, 50/60 Hz \pm 5%, (037LFU, 055LFU, and 075LFU 3phase only)				
Rated input current (A)	1-phase	3.5	5.8	6.7	9.0	11.2
	3-phase	2.0	3.4	3.9	5.2	6.5
Rated output voltage *3		3-phase: 200 to 240V (corresponding to input voltage)				
Rated output current (A)		1.6	2.6	3.0	4.0	5.0
Efficiency at 100% rated output (%)		90.5	92.8	93.6	94.1	95.4
Watt loss, approximate (W)	at 70% output	15	21	25	31	38
	at 100% output	19	29	32	41	51
Starting torque *6		200% or more				
Dynamic braking approx. % torque, short time stop *7	without resistor, from 50 / 60 Hz	100%: \leq 50Hz 50%: \leq 60Hz			70%: \leq 50Hz 50%: \leq 60Hz	
	with resistor	150%				
DC braking		Variable operating frequency, time, and braking force				
Weight	kg	0.7	0.85	0.85	1.3	1.3
	lb	1.54	1.87	1.87	2.87	2.87

Footnotes for the preceding table and the tables that follow:

- Note 1:** The protection method conforms to JEM 1030.
- Note 2:** The applicable motor refers to Hitachi standard 3-phase motor (4-pole). When using other motors, care must be taken to prevent the rated motor current (50/60 Hz) from exceeding the rated output current of the inverter.
- Note 3:** The output voltage decreases as the main supply voltage decreases (except when using the AVR function). In any case, the output voltage cannot exceed the input power supply voltage.
- Note 4:** To operate the motor beyond 50/60 Hz, consult the motor manufacturer for the maximum allowable rotation speed.
- Note 5:** When SLV is selected, please set the carrier frequency higher than 2.1 kHz.
- Note 6:** At the rated voltage when using a Hitachi standard 3-phase, 4-pole motor (when selecting sensorless vector control—SLV).
- Note 7:** The braking torque via capacitive feedback is the average deceleration torque at the shortest deceleration (stopping from 50/60 Hz as indicated). It is not continuous regenerative braking torque. The average deceleration torque varies with motor loss. This value decreases when operating beyond 50 Hz. If a large regenerative torque is required, the optional regenerative braking resistor should be used.
- Note 8:** The frequency command is the maximum frequency at 9.8V for input voltage 0 to 10 VDC, or at 19.6 mA for input current 4 to 20 mA. If this characteristic is not satisfactory for your application, contact your Hitachi sales representative.
- Note 9:** If operating the inverter at 40 to 50° C, reduce the carrier frequency to 2.1 kHz, derate the output current by 80%, and remove the top housing cover. Note that removing the top cover will nullify the NEMA rating for the inverter housing.
- Note 10:** The storage temperature refers to the short-term temperature during transport.
- Note 11:** Conforms to the test method specified in JIS C0911 (1984). For the model types excluded in the standard specifications, contact your Hitachi sales representative.
- Note 12:** The input voltage of xxLFU is 230V.

SJ100 Inverter Specifications, continued...

Item		200V Class Specifications, continued				
SJ100 inverters, 200V models	CE version	015NFE	022NFE	—	—	—
	UL version	015NFU	022NFU	037LFU	055LFU	075LF
Applicable motor size *2	kW	1.5	2.2	3.7	5.5	7.5
	HP	2	3	5	7.5	10
Rated capacity (kVA) *12	230V	3.1	4.3	6.9	9.5	12.7
	240V	3.0	4.5	7.2	9.9	13.3
Rated input voltage		1-phase: 200 to 240V +5/-10%, 50/60 Hz ±5%, 3-phase: 200 to 240V +5/-10%, 50/60 Hz ±5%, (037LFU, 055LFU, 075LFU 3-phase only)				
Rated input current (A)	1-phase	17.5	24.0	—	—	—
	3-phase	10.0	14.0	22.0	30.0	40.0
Rated output voltage *3		3-phase: 200 to 240V (corresponding to input voltage)				
Rated output current (A)		8.0	11.0	17.5	24	32
Efficiency at 100% rated output (%)		94.7	95.1	95.1	96.1	96.2
Watt loss, approximate (W)	at 70% output	57	78	130	152	204
	at 100% output	79	107	181	216	288
Starting torque *6		200% or more		180% or more		
Dynamic braking approx. % torque, short time stop *7	without resistor, from 50 / 60 Hz	70%: ≤ 50Hz 50%: ≤ 60Hz	20%: ≤ 50Hz 20%: ≤ 60Hz			
	with resistor	150%	100%		80%	
DC braking		Variable operating frequency, time, and braking force				
Weight	kg	2.2	2.8	2.8	5.5	5.7
	lb	4.85	6.17	6.17	12.13	12.57

Item		400V Class Specifications			
SJ100 inverters, 400V models	CE version	004HFE	007HFE	015HFE	022HFE
	UL version	004HFU	007HFU	015HFU	022HFU
Applicable motor size *2	kW	0.4	0.75	1.5	2.2
	HP	1/2	1	2	3
Rated capacity (460V) kVA		1.1	1.9	2.9	4.2
Rated input voltage		3-phase: 380 to 460V ±10%, 50/60 Hz ±5%			
Rated input current (A)		2.0	3.3	5.0	7.0
Rated output voltage *3		3-phase: 380 to 460V (corresponding to input voltage)			
Rated output current (A)		1.5	2.5	3.8	5.5
Efficiency at 100% rated output (%)		92.0	93.7	95.7	95.8
Watt loss, approximate (W)	at 70% output	25	33	48	68
	at 100% output	32	44	65	92
Starting torque *6		200% or more			
Dynamic braking approx. % torque, short time stop *7	without resistor, from 50/60 Hz	100%: ≤ 50Hz 50%: ≤ 60Hz			70%: ≤ 50Hz 20%: ≤ 60Hz
	with resistor	150%			100%
DC braking		Variable operating frequency, time, and braking force			
Weight	kg	1.3	1.7	1.7	1.8
	lb	2.87	3.75	3.75	3.97

Item		400V Class Specifications, continued			
SJ100 inverters, 400V models	CE version	030HFE	040HFE	055HFE	075HFE
	UL version	—	040HFU	055HFU	075HFU
Applicable motor size *2	kW	3.0	4.0	5.5	7.5
	HP	4	5	7.5	10
Rated capacity (460V) kVA		6.2	6.6	10.3	12.7
Rated input voltage		3-phase: 380 to 460V $\pm 10\%$, 50/60 Hz $\pm 5\%$			
Rated input current (A)		10.0	11.0	16.5	20.0
Rated output voltage *3		3-phase: 380 to 460V (corresponding to input voltage)			
Rated output current (A)		7.8	8.6	13	16
Efficiency at 100% rated output (%)		95.4	96.2	96.0	96.5
Watt loss, approximate (W)	at 70% output	100	108	156	186
	at 100% output	138	151	219	261
Starting torque *6		180% or more			
Dynamic braking approx. % torque, short time stop *7	without resistor, from 50/60 Hz	20%: $\leq 50\text{Hz}$ 20%: $\leq 60\text{Hz}$			
	with resistor	100%		80%	
DC braking		Variable operating frequency, time, and braking force			
Weight	kg	2.8	2.8	5.5	5.7
	lb	6.17	6.17	12.13	12.57

General Specifications

The following table applies to all SJ100 inverters.

Item	General Specifications
Protective housing *1	IP20
Control method	Sine wave pulse-width modulation (PWM) control
Output frequency range *4	0.5 to 360 Hz
Frequency accuracy	Digital command: 0.01% of the maximum frequency Analog command: 0.1% of the maximum frequency (25°C \pm 10°C)
Frequency setting resolution	Digital: 0.1 Hz; Analog: max. frequency/1000
Volt./Freq. characteristic *5	V/f optionally variable, V/f control (constant torque, reduced torque), sensorless vector control
Overload current rating	150%, 60 seconds
Acceleration/deceleration time	0.1 to 3000 sec., (linear accel/decel), second accel/decel setting available

Item			General Specifications
Input signal	Freq. setting	Operator panel	Up and Down keys / Value settings
		Potentiometer	Analog setting
		External signal *8	0 to 10 VDC (input impedance 10k Ohms), 4 to 20 mA (input impedance 250 Ohms), Potentiometer (1k to 2k Ohms, 2W)
	FWD/REV Run	Operator panel	Run/Stop (Forward/Reverse run change by command)
		External signal	Forward run/stop, Reverse run/stop
	Intelligent input terminal	FW (forward run command), RV (reverse run command), CF1~CF4 (multi-stage speed setting), JG (jog command), 2CH (2-stage accel./decel. command), FRS (free run stop command), EXT (external trip), USP (startup function), SFT (soft lock), AT (analog current input select signal), RS (reset), PTC (thermal protection), DB (external DC braking command), SET (2nd setting selection), UP (remote control, accel.), DWN (remote control, decel.)	
Output signal	Intelligent output terminal	RUN (run status signal), FA1,2 (frequency arrival signal), OL (overload advance notice signal), OD (PID error deviation signal), AL (alarm signal)	
	Frequency monitor	PWM output; Select analog output frequency monitor, analog output current monitor or digital output frequency monitor	
Alarm output contact			ON for inverter alarm (1C contacts, both normally open or closed avail.)
Other functions			AVR function, curved accel/decel profile, upper and lower limiters, 16-stage speed profile, fine adjustment of start frequency, carrier frequency change (0.5 to 16 kHz) frequency jump, gain and bias setting, process jogging, electronic thermal level adjustment, retry function, trip history monitor, 2nd setting selection, auto tuning, fan ON/OFF selection
Protective function			Over-current, over-voltage, under-voltage, overload, extreme high/low temperature, CPU error, memory error, ground fault detection at startup, internal communication error, electronic thermal, CT error
Operating Environment	Temperature	Operating (ambient): -10 to 50°C (*9) / Storage: -25 to 70°C (*10)	
	Humidity	20 to 90% humidity (non-condensing)	
	Vibration *11	5.9 m/s ² (0.6G), 10 to 55 Hz	
	Location	Altitude 1,000 m or less, indoors (no corrosive gasses or dust)	
Coating color			Munsell 8.5YR6.2/0/2, cooling fins in base color of aluminum
Options			Remote operator unit, copy unit, cables for the units, braking unit, braking resistor, AC reactor, DC reactor, noise filter, DIN rail mounting

Derating Curves

The maximum available inverter current output is limited by the carrier frequency and ambient temperature. The carrier frequency is the inverter’s internal power switching frequency, settable from 0.5 kHz to 16 kHz. Choosing a higher carrier frequency tends to decrease audible noise, but it also increases the internal heating of the inverter, thus decreasing (derating) the maximum current output capability. Ambient temperature is the temperature just outside the inverter housing—such as inside the control cabinet where the inverter is mounted. A higher ambient temperature decreases (derates) the inverter’s maximum current output capacity.

Use the following derating curves to help determine the optimal carrier frequency setting for your inverter, and to find the output current derating. Be sure to use the proper curve for your particular SJ100 inverter model number.

- Legend:**
- Standard ratings at 40°C
 - Ratings at 50°C max. with top cover removed
 - - - - - Ratings at 55°C max. with top cover removed

SJ100-002NFE/NFU

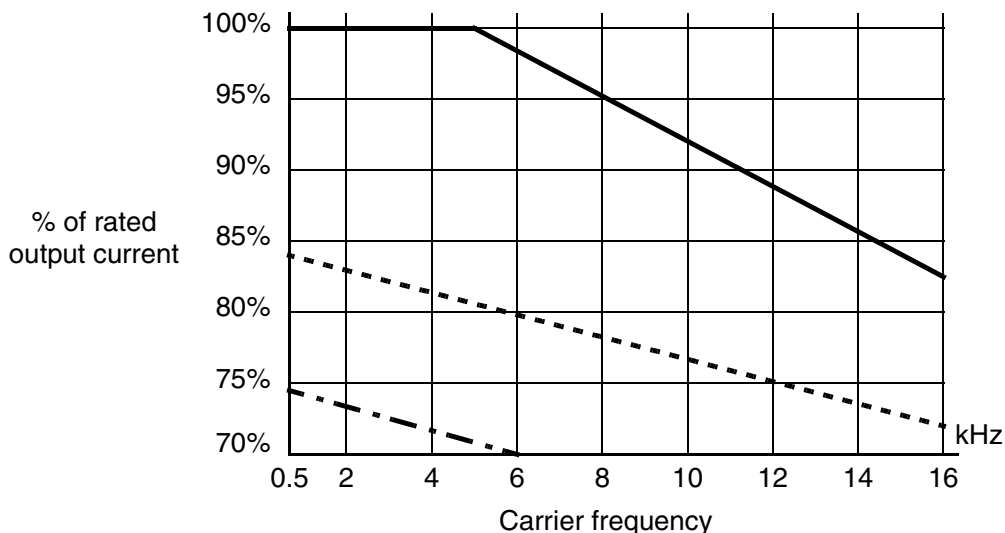

SJ100-004NFE/NFU

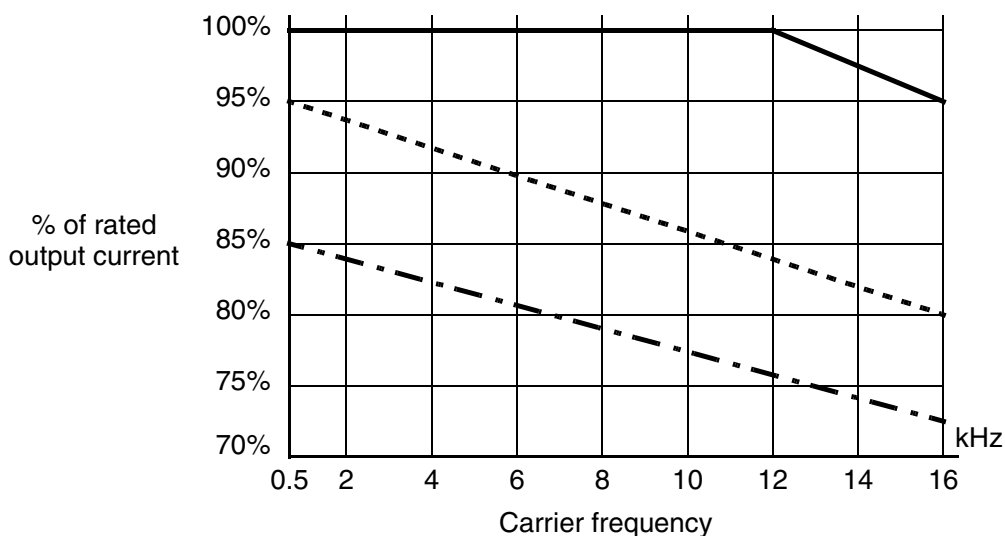

Derating curves, continued...

SJ100-007NFE/NFU

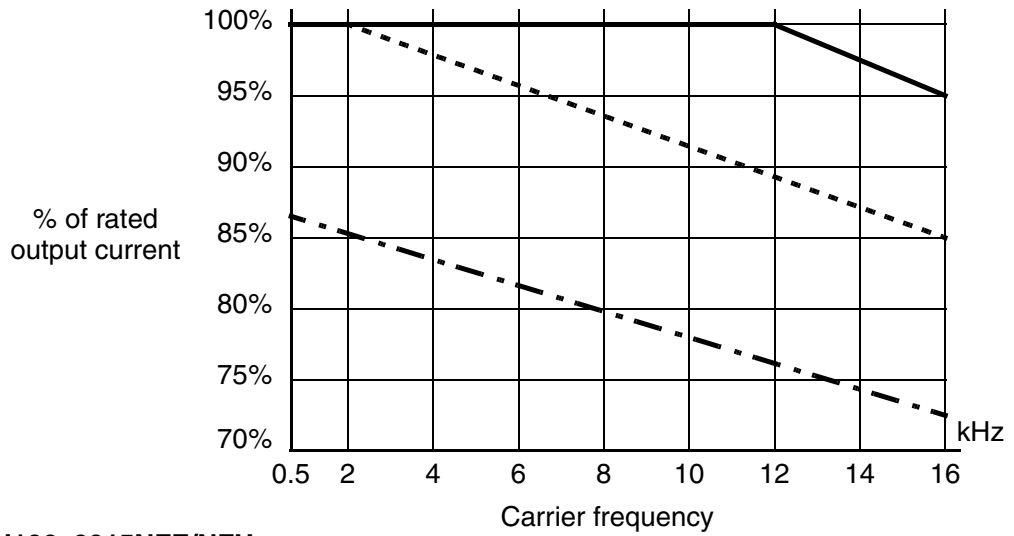

SJ100-0015NFE/NFU

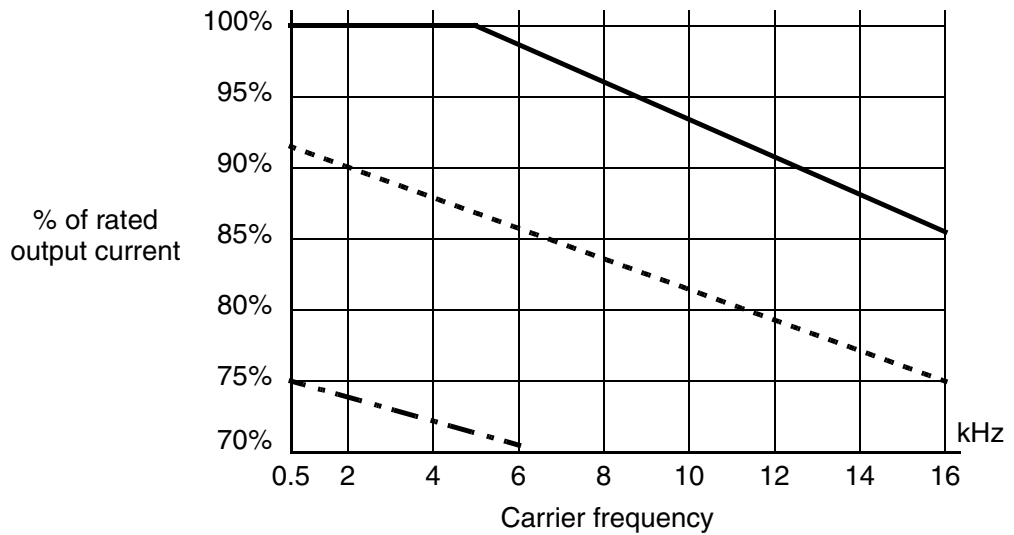

SJ100-022NFE/NFU

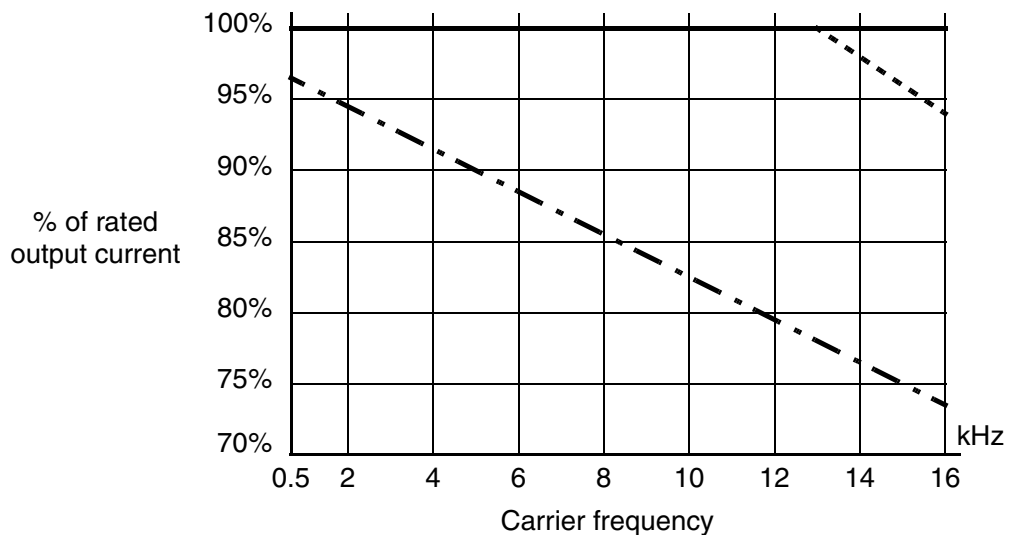

Derating curves, continued...

SJ100-037LF/LFU

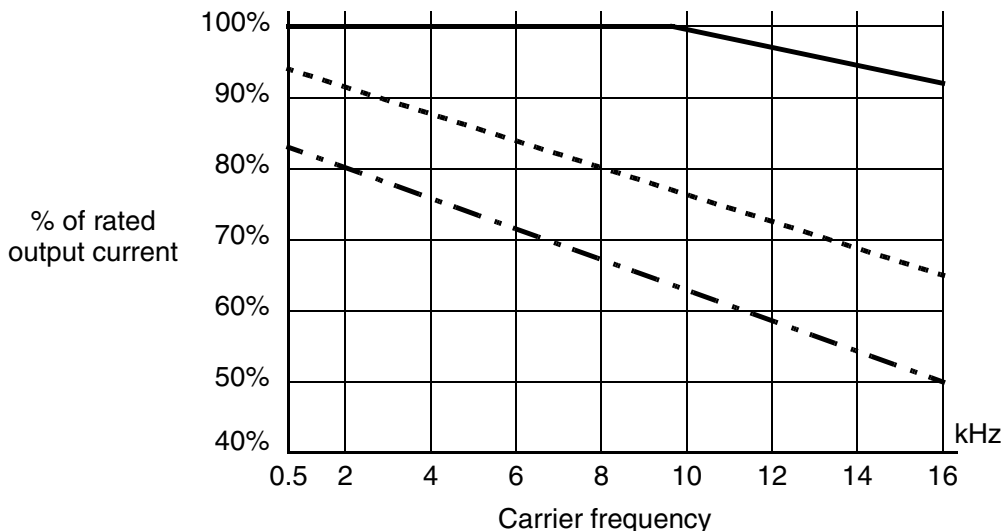

SJ100-055LFU

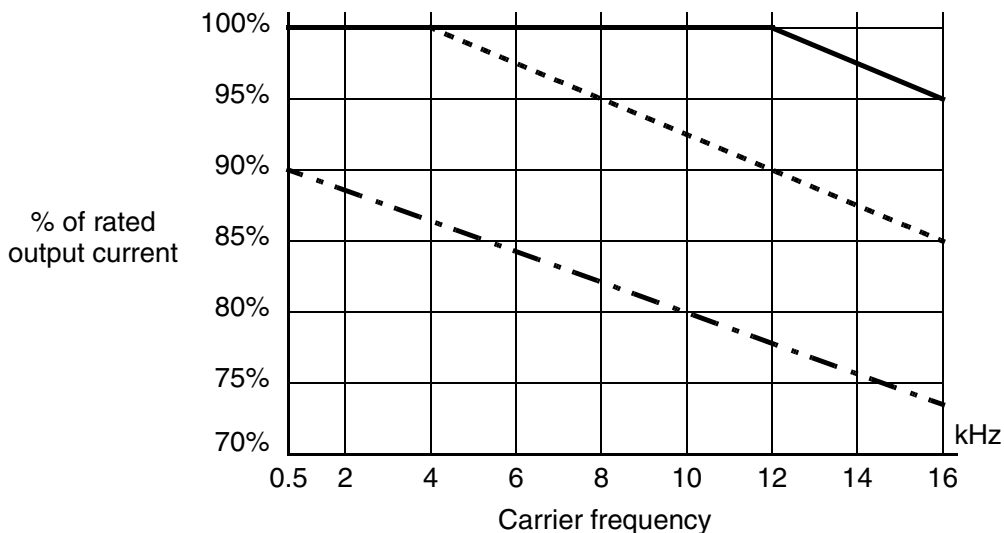

SJ100-075LFU

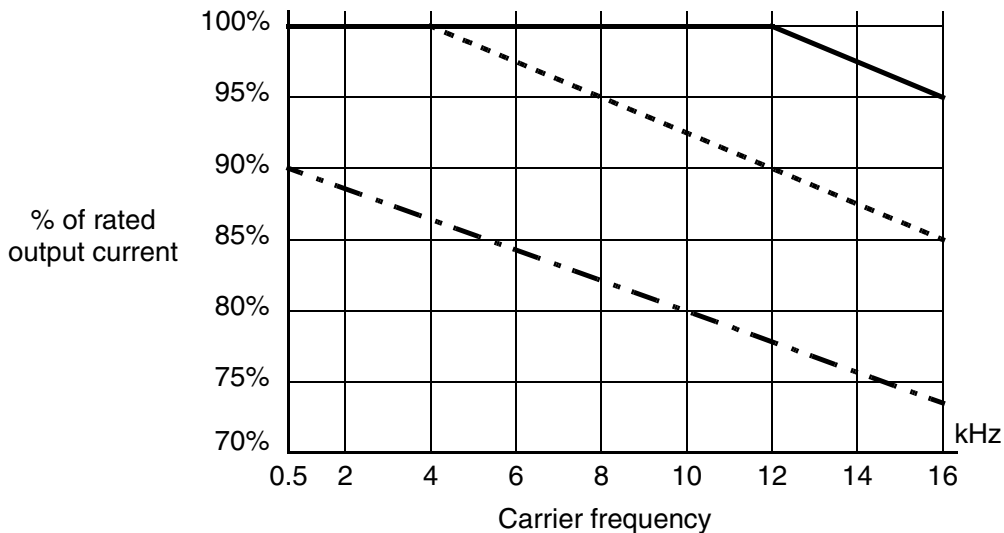

Derating curves, continued...

SJ100-004HFE/HFU

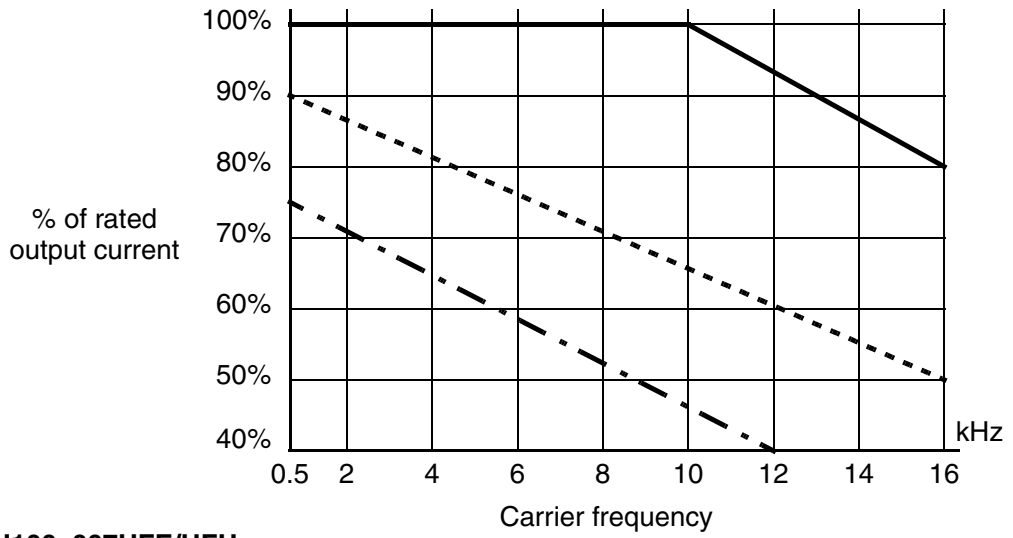

SJ100-007HFE/HFU

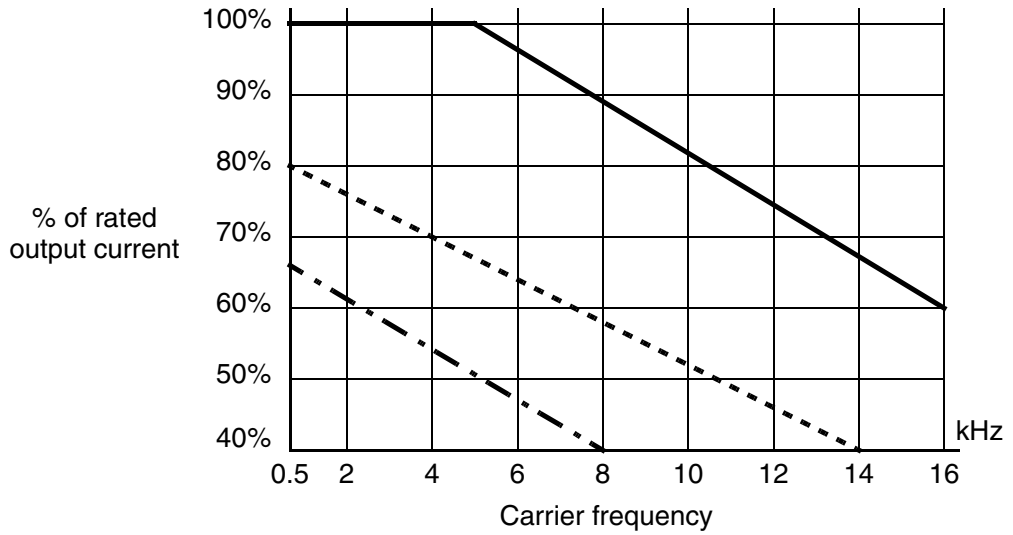

SJ100-015HFE/HFU

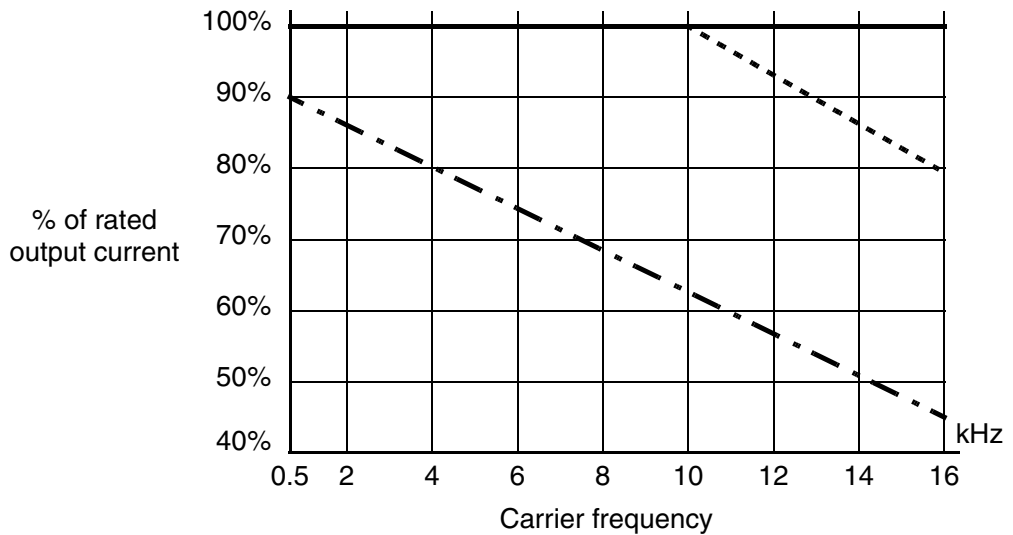

Derating curves, continued...

SJ100-022HFE/HFU

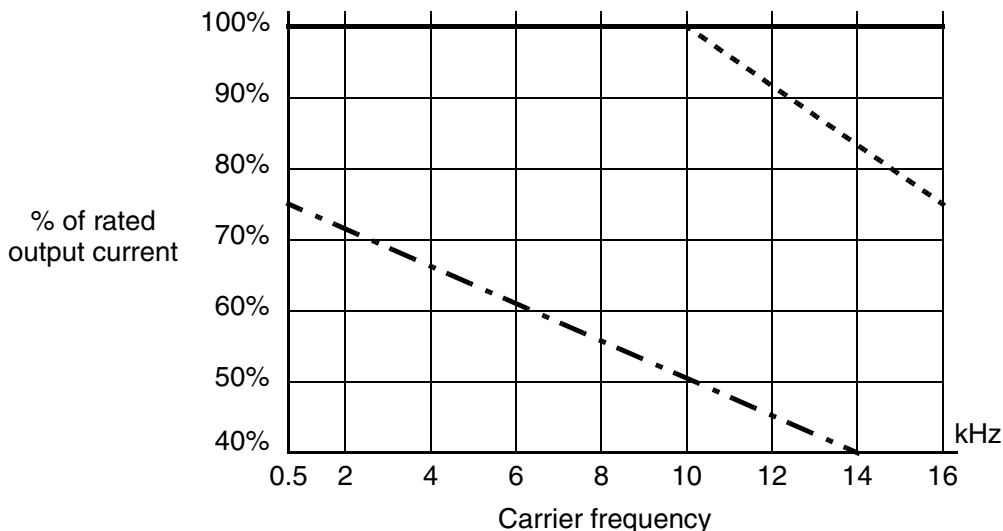

SJ100-040HFE/HFU

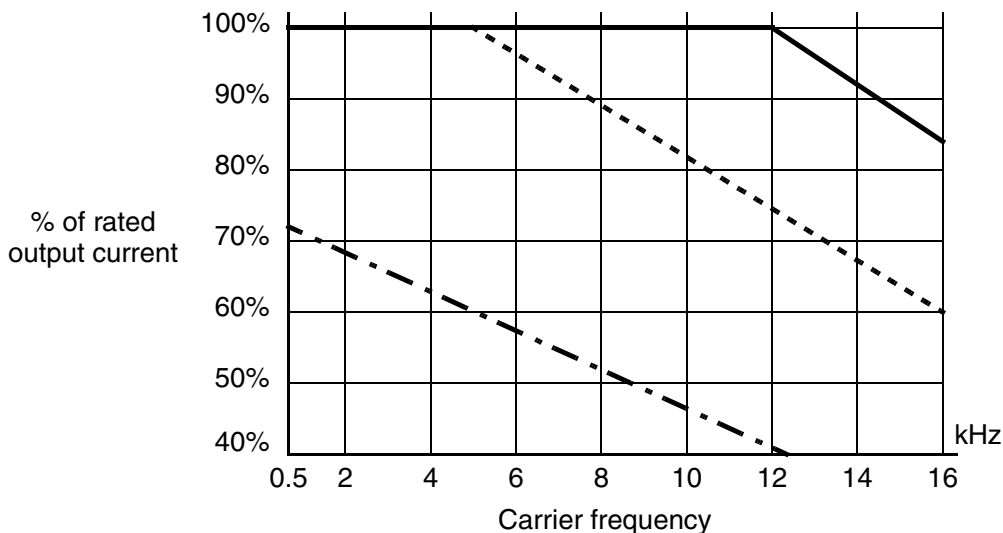

SJ100-055HFE/HFU

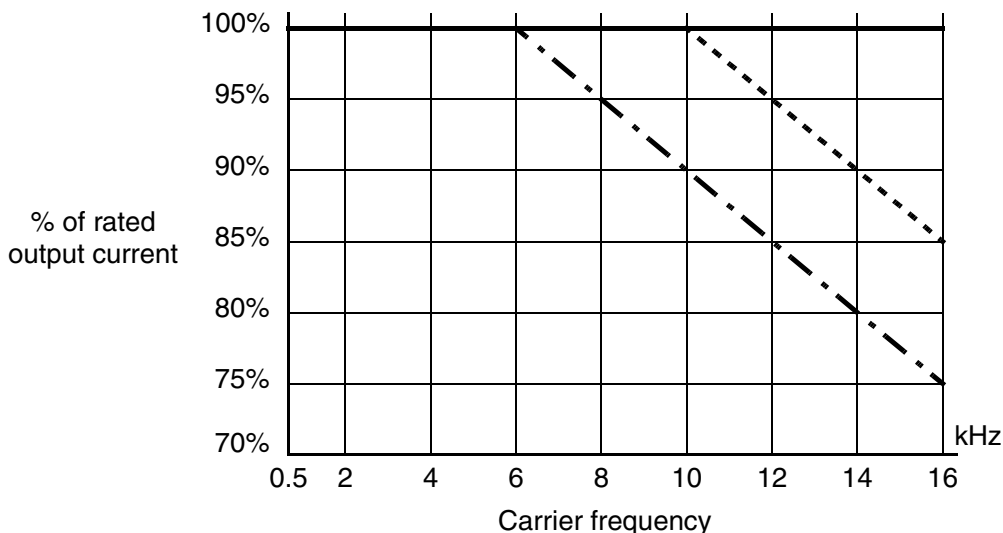

Derating curves, continued...

SJ100-075HFE/HFU

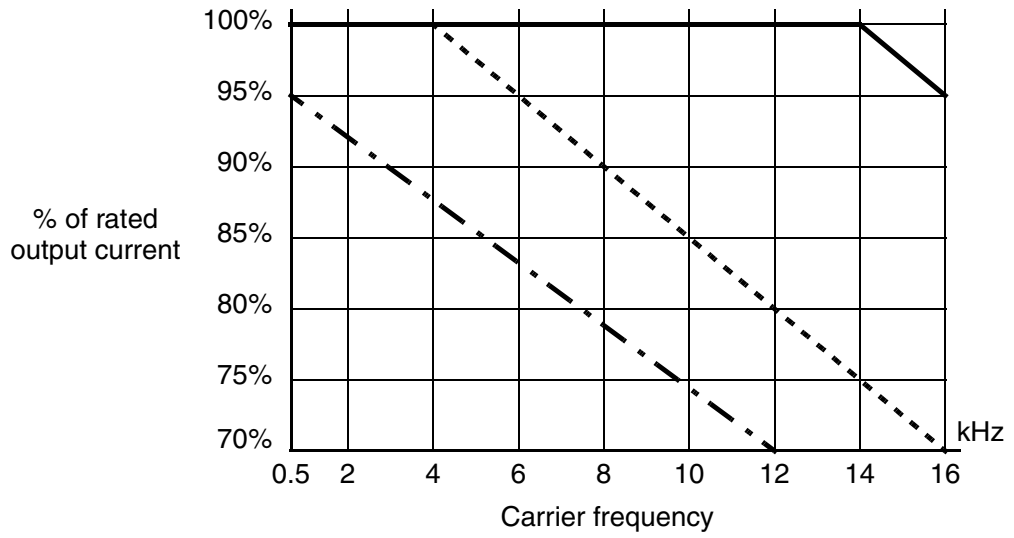

Introduction to Variable-Frequency Drives

The Purpose of Motor Speed Control for Industry

Hitachi inverters provide speed control for 3-phase AC induction motors. You connect AC power to the inverter, and connect the inverter to the motor. Many applications benefit from a motor with variable speed, in several ways:

- Energy savings - HVAC
- Need to coordinate speed with an adjacent process—textiles and printing presses
- Need to control acceleration and deceleration (torque)
- Sensitive loads - elevators, food processing, pharmaceuticals

What is an Inverter?

The term *inverter* and *variable-frequency drive* are related and somewhat interchangeable. An electronic motor drive for an AC motor can control the motor's speed by *varying the frequency* of the power sent to the motor.

An inverter, in general, is a device that converts DC power to AC power. The figure below shows how the variable-frequency drive employs an internal inverter. The drive first converts incoming AC power to DC through a rectifier bridge, creating an internal DC bus voltage. Then the inverter circuit converts the DC back to AC again to power the motor. The special inverter can vary its output frequency and voltage according to the desired motor speed.

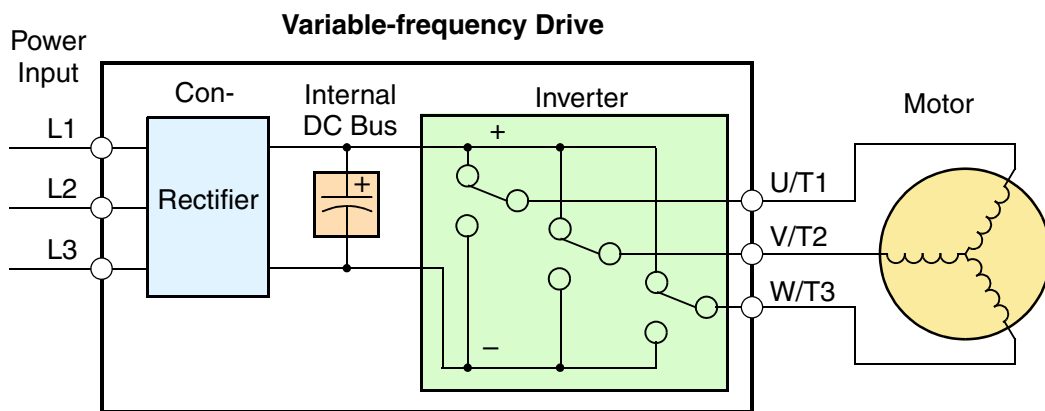

The simplified drawing of the inverter shows three double-throw switches. In Hitachi inverters, the switches are actually IGBTs (isolated gate bipolar transistors). Using a commutation algorithm, the microprocessor in the drive switches the IGBTs on and off at a very high speed to create the desired output waveforms. The inductance of the motor windings helps smooth out the pulses.

Torque and Constant Volts/Hertz Operation

In the past, AC variable speed drives used an open loop (scalar) technique to control speed. The constant-volts-per-hertz operation maintains a constant ratio between the applied voltage and the applied frequency. With these conditions, AC induction motors inherently delivered constant torque across the operating speed range. For some applications, this scalar technique was adequate.

Today, with the advent of sophisticated micro-processors and digital signal processors (DSPs), it is possible to control the speed and torque of AC induction motors with unprecedented accuracy. The SJ100 utilizes these devices to perform complex mathematical calculations required to achieve superior performance. The technique is referred to as sensorless vector control. It allows the drive to continuously monitor its output voltage and current, and their relationship to each other. From this it mathematically calculates two vector currents. One vector is related to motor flux current, and the other to motor torque current. The ability to separately control these two vectors is what allows the SJ100 to deliver extraordinary low-speed performance and speed control accuracy.

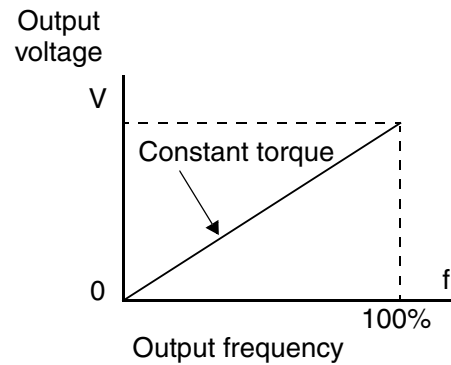

Inverter Input and Three-Phase Power

The Hitachi SJ100 Series of inverters includes two sub-groups: the 200V class and the 400V class inverters. The drives described in this manual may be used in either the United States or Europe, although the exact voltage level for commercial power may be slightly different from country to country. Accordingly, a 200V class inverter requires (nominal) 200 to 240VAC, and a 400V class inverter requires from 380 to 460VAC. Some 200V class inverters will accept single-phase or three-phase power, but all 400V class inverters require a three-phase power supply.



TIP: If your application only has single phase power available, refer to SJ100 inverters of 3HP or less; they can accept single phase input power.

The common terminology for single phase power is Line (L) and Neutral (N). Three-phase power connections are usually labeled Line 1 (L1), Line 2 (L2) and Line 3 (L3). In any case, the power source should include an earth ground connection. That ground connection will need to connect to the inverter chassis and to the motor frame (see [“Wire the Inverter Output to Motor”](#) on page 2-18).

Inverter Output to the Motor

The AC motor must be connected only to the inverter's output terminals. The output terminals are uniquely labeled (to differentiate them from the input terminals) with the designations U/T1, V/T2, and W/T3. This corresponds to typical motor lead connection designations T1, T2, and T3. It is often not necessary to connect a particular inverter output to a particular motor lead for a new application. The consequence of swapping any two of the three connections is the reversal of the motor direction. In applications where reversed rotation could cause equipment damage or personnel injury, be sure to verify direction of rotation before attempting full-speed operation. For safety to personnel, you must connect the motor chassis ground to the ground connection at the bottom of the inverter housing.

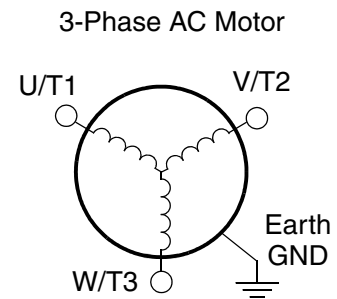

Notice the three connections to the motor do not include one marked “Neutral” or “Return.” The motor represents a balanced “Y” impedance to the inverter, so there is no need for a separate return. In other words, each of the three “Hot” connections serves also as a return for the other connections, because of their phase relationship.

The Hitachi inverter is a rugged and reliable device. The intention is for the inverter to assume the role of controlling power to the motor during all normal operations. Therefore, this manual instructs you not to switch off power to the inverter *while the motor is running* (unless it is an emergency stop). Also, do not install or use disconnect switches in the wiring from the inverter to the motor (except thermal disconnect). Of course, safety-related devices such as fuses must be in the design to break power during a malfunction, as required by NEC and local codes.

Intelligent Functions and Parameters

Much of this manual is devoted to describing how to use inverter functions and how to configure inverter parameters. The inverter is microprocessor-controlled, and has many independent functions. The microprocessor has an on-board EEPROM for parameter storage. The inverter's front panel keypad provides access to all functions and parameters, which you can access through other devices as well. The general name for all these devices is the *digital operator*, or *digital operator panel*. Chapter 2 will show you how to get a motor running, using a minimal set of function commands or configuring parameters.

The optional read/write programmer will let you read and write inverter EEPROM contents from the programmer. This feature is particularly useful for OEMs who need to duplicate a particular inverter's settings in many other inverters in assembly-line fashion.



Braking

In general, braking is a force that attempts to slow or stop motor rotation. So it is associated with motor deceleration, but may also occur even when the load attempts to drive the motor faster than the desired speed (overhauling). If you need the motor and load to decelerate quicker than their natural deceleration during coasting, we recommend installing a braking resistor. The dynamic braking unit (built into the SJ100) sends excess motor energy into a resistor to slow the motor and load (see [“Introduction” on page 5-2](#) and [“Dynamic Braking” on page 5-5](#) for more information). For loads that continuously overhaul the motor for extended periods of time, the SJ100 may not be suitable (contact your Hitachi distributor).

The inverter parameters include acceleration and deceleration, which you can set to match the needs of the application. For a particular inverter, motor, and load, there will be a range of practically achievable accelerations and decelerations.

Velocity Profiles

The SJ100 inverter is capable of sophisticated speed control. A graphical representation of that capability will help you understand and configure the associated parameters. This manual makes use of the velocity profile graph used in industry (shown at right). In the example, *acceleration* is a ramp to a set speed, and *deceleration* is a decline to a stop.

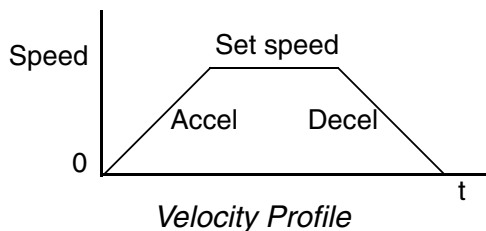

Acceleration and deceleration settings specify the time required to go from a stop to maximum frequency (or visa versa). The resulting slope (speed change divided by time) is the acceleration or deceleration. An increase in output frequency uses the acceleration slope, while a decrease uses the deceleration slope. The accel or decel time a particular speed change depends on the starting and ending frequencies. However, the slope is constant, corresponding to the full-scale accel or decel time setting. For example, the full-scale acceleration setting (time) may be 10 seconds—the time required to go from 0 to 60 Hz.

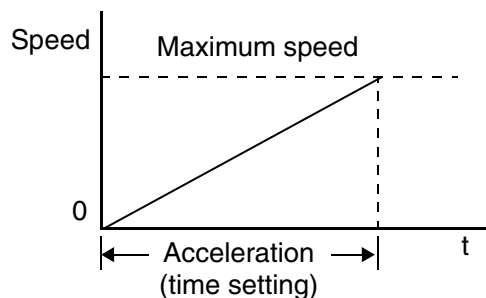

The SJ100 inverter can store up to 16 preset speeds. And, it can apply separate acceleration and deceleration transitions from any preset to any other preset speed. A multi-speed profile (shown at right) uses two or more preset speeds, which you can select via intelligent input terminals. This external control can apply any preset speed at any time. Alternatively, the selected speed is infinitely variable across the speed range. You can use the potentiometer control on the keypad for manual control. The drive accepts analog 0-10V signals and 4-20 mA control signals as well.

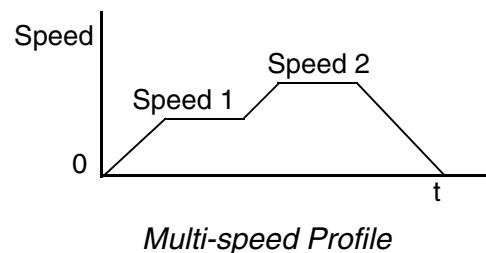

The inverter can drive the motor in either direction. Separate FW and RV commands select the direction of rotation. The motion profile example shows a forward motion followed by a reverse motion of shorter duration. The speed presets and analog signals control the magnitude of the speed, while the FWD and REV commands determine the direction before the motion starts.

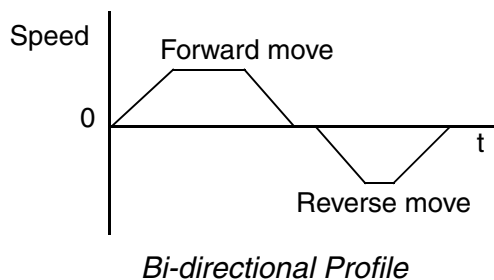

NOTE: The SJ100 can move loads in both directions. However, it is not designed for use in servo-type applications that use a bipolar velocity signal that determines direction.

Frequently Asked Questions

- Q.** What is the main advantage in using an inverter to drive a motor, compared to alternative solutions?
- A.** An inverter can vary the motor speed with very little loss of efficiency, unlike mechanical or hydraulic speed control solutions. The resulting energy savings usually pays for the inverter in a relatively short time.
- Q.** The term “inverter” is a little confusing, since we also use “drive” and “amplifier” to describe the electronic unit that controls a motor. What does “inverter” mean?
- A.** The terms *inverter*, *drive*, and *amplifier* are used somewhat interchangeably in industry. Nowadays, the terms *drive*, *variable-frequency drive*, *variable-speed drive*, and *inverter* are generally used to describe electronic, microprocessor-based motor speed controllers. In the past, *variable-speed drive* also referred to various mechanical means to vary speed. *Amplifier* is a term almost exclusively used to describe drives for servo or stepper motors.
- Q.** Although the SJ100 inverter is a variable speed drive, can I use it in a fixed-speed application?
- A.** Yes, sometimes an inverter can be used simply as a “soft-start” device, providing controlled acceleration and deceleration to a fixed speed. Other functions of the SJ100 may be useful in such applications, as well. However, using a variable speed drive can benefit many types of industrial and commercial motor applications, by providing controlled acceleration and deceleration, high torque at low speeds, and energy savings over alternative solutions.
- Q.** Can I use an inverter and AC induction motor in a positioning application?
- A.** That depends on the required precision, and the slowest speed the motor will must turn and still deliver torque. The SJ100 inverter will deliver full torque while turning the motor at only 0.5 Hz (15 RPM). **DO NOT** use an inverter if you need the motor to stop and hold the load position without the aid of a mechanical brake (use a servo or stepper motion control system).
- Q.** Does the optional digital operator interface or the PC software (DOP Professional) provide features beyond what is available from the keypad on the unit?
- A.** Yes. However, note first that the same set of parameters and functions are equally accessible from either the unit’s keypad or from remote devices. The DOP Professional PC software lets you save or load inverter configurations to or from a disk file. And, the hand-held digital operator provides hard-wired terminals, a safety requirement for some installations.

- Q.** Why does the manual or other documentation use terminology such as “200V class” instead of naming the actual voltage, such as “230 VAC?”
- A.** A specific inverter model is set at the factory to work across a voltage range particular to the destination country for that model. The model specifications are on the label on the side of the inverter. A European 200V class inverter (“EU” marking) has different parameter settings than a USA 200V class inverter (“US” marking). The initialization procedure (see [“Restoring Factory Default Settings” on page 6–8](#)) can set up the inverter for European or US commercial voltage ranges.
- Q.** Why doesn’t the motor have a neutral connection as a return to the inverter?
- A.** The motor theoretically represents a “balanced Y” load if all three stator windings have the same impedance. The Y connection allows each of the three wires to alternately serve as input or return on alternate half-cycles.
- Q.** Does the motor need a chassis ground connection?
- A.** Yes, for several reasons. Most importantly, this provides protection in the event of a short in the motor that puts a hazardous voltage on its housing. Secondly, motors exhibit leakage currents that increase with aging. Lastly, a grounded chassis generally emits less electrical noise than an ungrounded one.
- Q.** What type of motor is compatible with the Hitachi inverters?
- A.** **Motor type** – It must be a three-phase AC induction motor. Use an inverter-grade motor that has 800V insulation for 200V class inverters, or 1600V insulation for 400V class.
Motor size – In practice, it’s better to find the right size motor for your application; then look for the inverter to match the motor.



NOTE: There may be other factors that will affect motor selection, including heat dissipation, motor operating speed profile, enclosure type, and cooling method.

- Q.** How many poles should the motor have?
- A.** Hitachi inverters can be configured to operate motors with 2, 4, 6, or 8 poles. The greater the number of poles, the slower the top motor speed will be, but it will have higher torque at the base speed.
- Q.** Will I be able to add dynamic (resistive) braking to my Hitachi SJ100 drive after the initial installation?
- A.** Yes. The SJ100 inverter already has a dynamic braking circuit built in. Just add the resistor sized to meet the braking requirements. More information on dynamic braking is located in Chapter 5.

- Q.** How will I know if my application will require resistive braking?
- A.** For new applications, it may be difficult to tell before you actually test a motor/drive solution. In general, some applications can rely on system losses such as friction to serve as the decelerating force, or otherwise can tolerate a long decel time. These applications will not need dynamic braking. However, applications with a combination of a high-inertia load and a required short decel time will need dynamic braking. This is a physics question that may be answered either empirically or through extensive calculations.
- Q.** Several options related to electrical noise suppression are available for the Hitachi inverters. How can I know if my application will require any of these options?
- A.** The purpose of these noise filters is to reduce the inverter electrical noise so the operation of nearby electrical devices is not affected. Some applications are governed by particular regulatory agencies, and noise suppression is mandatory. In those cases, the inverter must have the corresponding noise filter installed. Other applications may not need noise suppression, unless you notice electrical interference with the operation of other devices.
- Q.** The SJ100 features a PID loop feature. PID loops are usually associated with chemical processes, heating, or process industries in general. How could the PID loop feature be useful in my application?
- A.** You will need to determine the particular main variable in your application the motor affects. That is the process variable (PV) for the motor. Over time, a faster motor speed will cause a faster change in the PV than a slow motor speed will. By using the PID loop feature, the inverter commands the motor to run at the optimal speed required to maintain the PV at the desired value for current conditions. Using the PID loop feature will require an additional sensor and other wiring, and is considered an advanced application.

Inverter Mounting and Installation

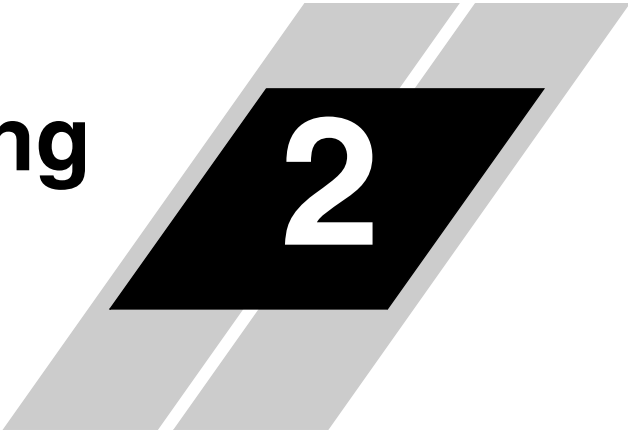

In This Chapter....	page
— Orientation to Inverter Features	2
— Basic System Description	5
— Step-by-Step Basic Installation	6
— Powerup Test	19
— Using the Front Panel Keypad	21

Orientation to Inverter Features

Unpacking and Inspection

Please take a few moments to unpack your new SJ100 inverter and perform these steps:

1. Look for any damage that may have occurred during shipping.
2. Verify the contents of the box include:
 - a. One SJ100 inverter
 - b. One Instruction Manual with self-adhesive label for the inverter
 - c. One SJ100 Quick Reference Guide
 - d. One packet of desiccant—discard (not for human consumption)
3. Inspect the specifications label on the side of the inverter. Make sure it matches the product part number you ordered.

Main Physical Features

The SJ100 Series inverters vary in size according to the current output rating and motor size for each model number. All feature the same basic keypad and connector interface for consistent ease of use. The inverter construction has a heat sink at the back of the housing. The larger models include a fan(s) to enhance heat sink performance. The mounting holes are pre-drilled in the heat sink for your convenience. Never touch the heat sink during or just after operation; it can be very hot.

The electronics housing and front panel are built onto the front of the heat sink. The front panel has three levels of physical access designed for convenience and safety:

- **First-level access** – for basic use of inverter and editing parameters (power ON)
- **Second-level access** – for editing parameters and wiring control signals (power ON)
- **Third-level access** – for wiring the inverter power supply or motor (power OFF)

1. **First-level Access** - View the unit just as it came from the box as shown. The four-digit display can show a variety of performance parameters. LEDs indicate whether the display units are Hertz or Amperes. Other LEDs indicate Power (external), and Run/Stop Mode and Program/Monitor Mode status. Membrane keys Run and Stop/Reset, and a Min/Max frequency control knob control motor operation. These controls and indicators are usually the only ones needed after the inverter installation is complete. You can also access the modular jack for connecting a programming or monitoring device such as a PC (see Chapter 3). And, you can access the two chassis GND screws on the metal tab at the bottom of the inverter.



2. Second-level access - Locate the lift tab at the right lower corner of the front panel near the safety warning message. Lift the corner to swing the half-door around to the left. This exposes four more control buttons and some connectors.

The FUNC., ▲, ▼, and STR keys allow an operator to access and change the inverter's functions and parameter values. The two 8-position connectors provide the interface for logic-level control signals. These signals are generally low-voltage in nature and are appropriate for second-level access.



Locate the label sheet that came with the manual. This is a good moment to apply the self-sticking labels as shown below. Adhere the larger label for monitor codes and basic functions to the rear of the half-door panel. Then adhere the remaining trip code label to the area beside the connectors. Be careful not to cover the screw access on models like the one shown.

MONITOR			
P01	Output frequency	P08	TRIP
P02	Output current	P09	TRIP history
BASIC FUNCTION			
F01	Output frequency	R01	Frequency destination
F02	Acceleration time	R02	Run command destination
F03	Deceleration time	R03	Base frequency
F04	Running direction	R04	Maximum frequency
For the other description of Monitor/Setting, see the manual.			
USER SETTING			

TRIP	
E01	Overcurrent (Const.)
E02	Overcurrent (Decel.)
E03	Overcurrent (Accel.)
E05	Overload
E07	Overvoltage
E09	Undervoltage
E14	Ground fault
E21	Thermal TRIP

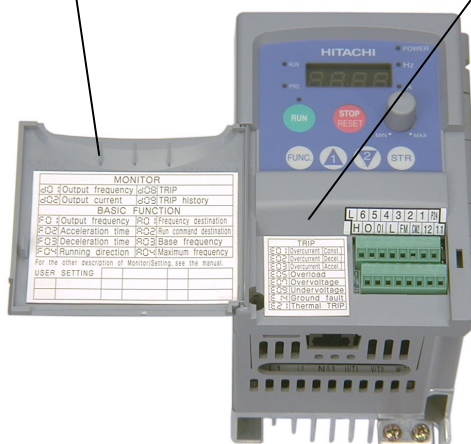

3. Third-level access - First, ensure no power source of any kind is connected to the inverter. If power has been connected, wait five minutes after powerdown and verify the Power LED is OFF to proceed. Then locate the recessed retention screw on the left side main front panel (it is along the left hinge area on some models, or behind the first access door on others). Use a small screwdriver (Regular or Phillips) to loosen the screw. Swing the door around to the right to reveal the internal components of the drive. The two-level tiered 12-position terminal block accepts wires for the power input and wires to the motor.

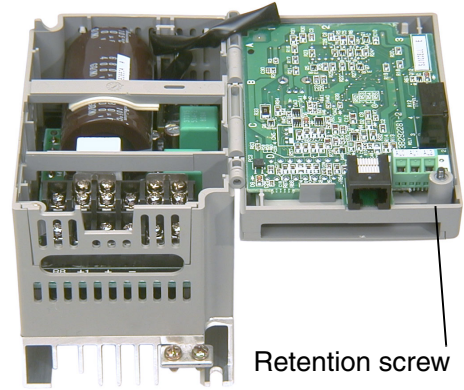

Notice the housing partition that lifts out to allow full access to the terminals for wiring as shown. Never operate the inverter drive with the partition removed or the full access door opened.

The alarm circuit connections are accessible on the 3-position connector near the modular connector on the rear of the main panel door. The nearby relay provides both normally-open and normally-closed logic for interface to an external alarm. The alarm circuit may carry hazardous live voltages even when the main power to the inverter is OFF. So, never directly touch any terminal or circuit component. A notch in the removable partition serves as the exit path for alarm circuit wiring.

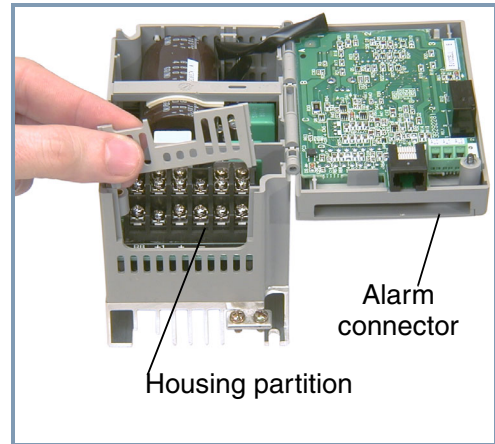

The following sections will describe the system design and guide you through a step-by-step installation process. After the section on wiring, this chapter will show how to use the front panel keys to access functions and edit parameters.

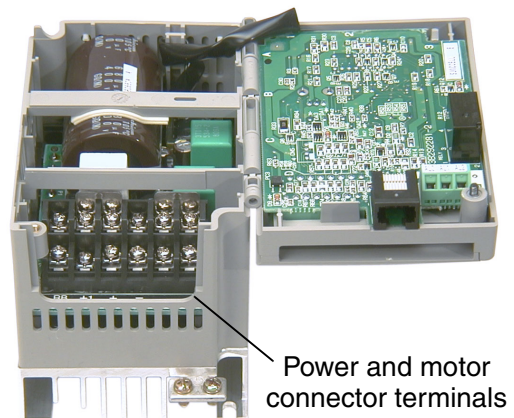

Basic System Description

A motor control system will obviously include a motor and inverter, as well as a breaker or fuses for safety. If you are connecting a motor to the inverter on a test bench just to get started, that's all you may need for now. But a system can also have a variety of additional components. Some can be for noise suppression, while others may enhance the inverter's braking performance. The figure and table below show a system with all the optional components you may need in your finished application.

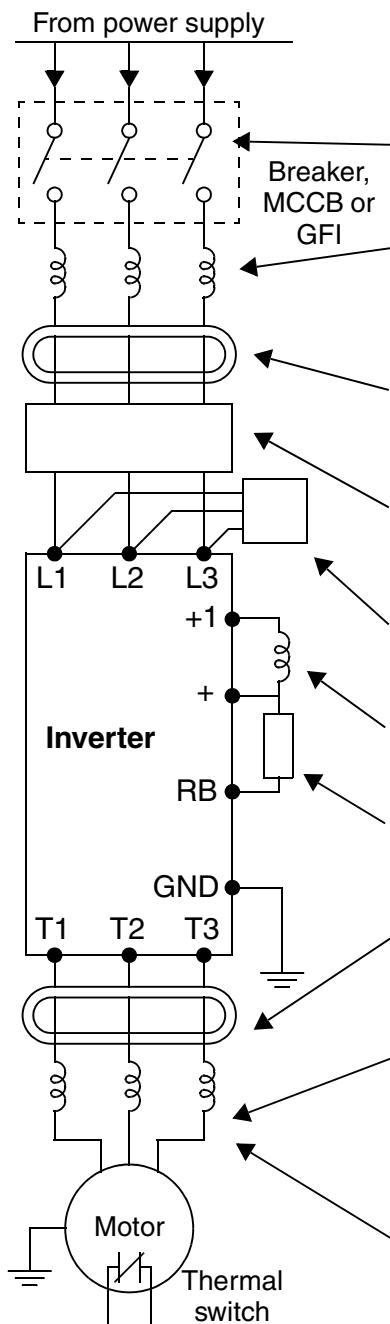

Name	Function
Breaker / disconnect	A molded-case circuit breaker (MCCB), ground fault interrupter (GFI), or a fused disconnect device. NOTE: The installer must refer to the NEC and local codes to ensure safety and compliance.
Input-side AC Reactor	This is useful in suppressing harmonics induced on the power supply lines and for improving the power factor. WARNING: Some applications <i>must</i> use an input-side AC reactor to prevent inverter damage. See Warning on next page.
Radio noise filter	Electrical noise interference may occur on nearby equipment such as a radio receiver. This magnetic choke filter helps reduce radiated noise (can also be used on output).
EMI filter (for CE applications, see Appendix D)	Reduces the conducted noise on the power supply wiring between the inverter and the power distribution system. Connect to the inverter primary (input side).
Radio noise filter (use in non-CE applications)	This capacitive filter reduces radiated noise from the main power wires in the inverter input side.
DC link choke	Suppresses harmonics generated by the inverter. However, it will not protect the input diode bridge rectifier.
Braking resistor	This is useful for increasing the inverter's control torque for high duty-cycle (ON-OFF) applications, and improving the decelerating capability.
Radio noise filter	Electrical noise interference may occur on nearby equipment such as a radio receiver. This magnetic choke filter helps reduce radiated noise (can also be used on input).
Output-side AC reactor	This reactor reduces the vibrations in the motor caused by the inverter's switching waveforms, by smoothing the waveform to approximate commercial power quality. It is also useful to reduce harmonics when wiring from the inverter to the motor is more than 10m in length.
LCR filter	Sine wave shaping filter for output side.

Inverter Mounting and Installation



NOTE: Note that some components are required for regulatory agency compliance (see Chapter 5 and Appendix C).



WARNING: In the cases below involving a general-purpose inverter, a large peak current can flow on the power supply side, sometimes destroying the converter module:

1. The unbalance factor of the power supply is 3% or higher.
2. The power supply capacity is at least 10 times greater than the inverter capacity (or the power supply capacity is 500 kVA or more).
3. Abrupt power supply changes are expected, due to conditions such as:
 - a. Several inverters are interconnected with a short bus.
 - b. A thyristor converter and an inverter are interconnected with a short bus.
 - c. An installed phase advance capacitor opens and closes.

Where these conditions exist or when the connected equipment must be highly reliable, you **MUST** install an input-side AC reactor of 3% (at a voltage drop at rated current) with respect to the supply voltage on the power supply side. Also, where the effects of an indirect lightning strike are possible, install a lightning conductor.

Step-by-Step Basic Installation

This section will guide you through the following basic steps of installation:

1. Study the warnings and instructions associated with mounting the inverter.
2. Select a suitable mounting location.



NOTE: If the installation is in an EU country, study the EMC installation guidelines in Appendix C.

3. Place covers over the inverter's ventilation openings to prevent debris from entering.
4. Check the inverter mounting dimensions for footprint and mounting hole locations.
5. Study the caution and warning messages associated with wiring the inverter.
6. Connect wiring for the inverter power input.
7. Connect wiring to the motor.
8. Remove any covers applied in Step 3 from the inverter's ventilation openings.



CAUTION: The inverter is shipped with a plastic cover over the top vent grill. **REMOVE** this cover after the installation is complete. Operation with this cover in place will not allow proper cooling, and damage to the inverter may result.

9. Perform a powerup test.
10. Make observations and check your installation.

Choosing a Mounting Location



Step 1: Study the following caution messages associated with mounting the inverter. This is the time when mistakes are most likely to occur that will result in expensive rework, equipment damage, or personal injury.



CAUTION: Be sure to install the unit on flame-resistant material such as a steel plate. Otherwise, there is the danger of fire.



CAUTION: Be sure not to place any flammable materials near the inverter. Otherwise, there is the danger of fire.



CAUTION: Be sure not to let the foreign matter enter vent openings in the inverter housing, such as wire clippings, spatter from welding, metal shavings, dust, etc. Otherwise, there is the danger of fire.



CAUTION: Be sure to install the inverter in a place that can bear the weight according to the specifications in the text (Chapter 1, Specifications Tables). Otherwise, it may fall and cause injury to personnel.



CAUTION: Be sure to install the unit on a perpendicular wall that is not subject to vibration. Otherwise, it may fall and cause injury to personnel.



CAUTION: Be sure not to install or operate an inverter that is damaged or has missing parts. Otherwise, it may cause injury to personnel.



CAUTION: Be sure to install the inverter in a well-ventilated room that does not have direct exposure to sunlight, a tendency for high temperature, high humidity or dew condensation, high levels of dust, corrosive gas, explosive gas, inflammable gas, grinding-fluid mist, salt damage, etc. Otherwise, there is the danger of fire.

Ensure Adequate Ventilation

2

Step 2: To summarize the caution messages—you will need to find a solid, non-flammable, vertical surface that is in a relatively clean and dry environment. In order to ensure enough room for air circulation around the inverter to aid in cooling, maintain the specified clearance around the inverter specified in the diagram.

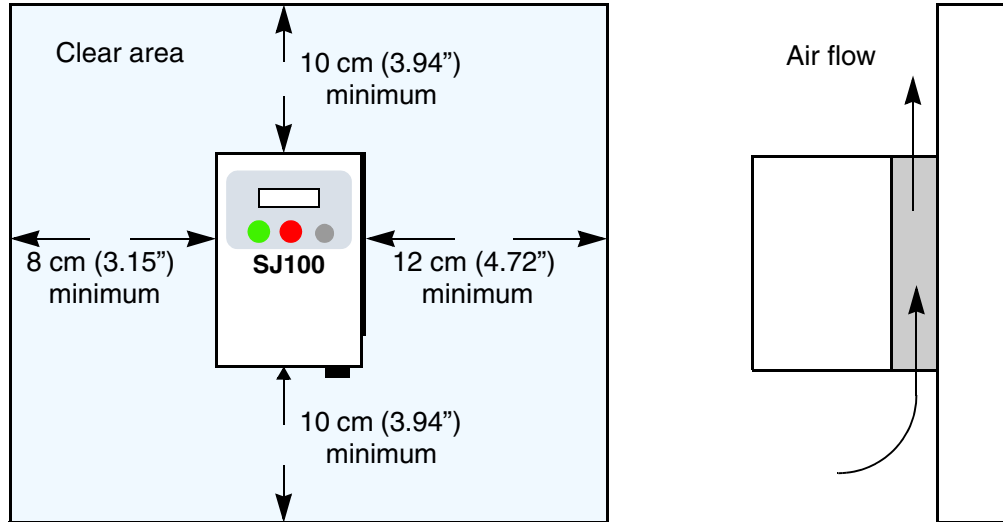

CAUTION: Be sure to maintain the specified clearance area around the inverter and to provide adequate ventilation. Otherwise, the inverter may overheat and cause equipment damage or fire.

Keep Debris Out of Inverter Vents

3

Step 3: Before proceeding to the wiring section, it's a good time to temporarily cover the inverter's ventilation openings. Paper and masking tape are all that is needed. This will prevent harmful debris such as wire clippings and metal shavings from entering the inverter during installation. The inverter housing comes from the factory with a snap-in cover on the top of its housing. Ensure it is in place at this time (also to be removed later, unless the installation must have a NEMA rating).

Please observe this checklist while mounting the inverter:

1. The ambient temperature must be in the range of -10 to 40°C. If the range will be up to 50°C, you will need to set the carrier frequency to 2.1 kHz or less and derate the output current to 80% or less. Chapter 3 covers how to change parameters such as the carrier frequency. Remember to remove the top cover (unless the installation is to have a NEMA rating)!
2. Keep any other heat-producing equipment as far away from the inverter as possible.

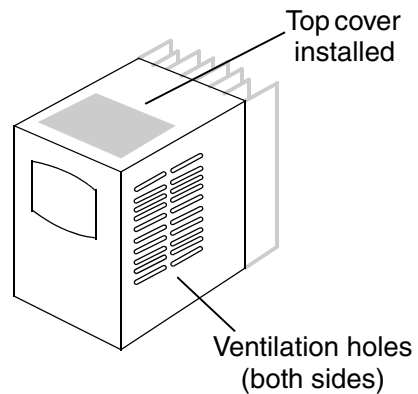

3. When installing the inverter in an enclosure, maintain the clearance around the inverter and verify that its ambient temperature is within specification when the enclosure door is closed.
4. Do not open the main front panel door at any time during operation.

Check Inverter Dimensions

Step 4: Locate the applicable drawing on the following pages for your inverter. Dimensions are given in millimeters (inches) format.

External Dimensions

MODEL	H mm (in.)
SJ100 -002NFE	93 (3.66)
-002NFU	93 (3.66)
-004NFE	107 (4.21)
-004NFU	107 (4.21)
-005NFE	107 (4.21)

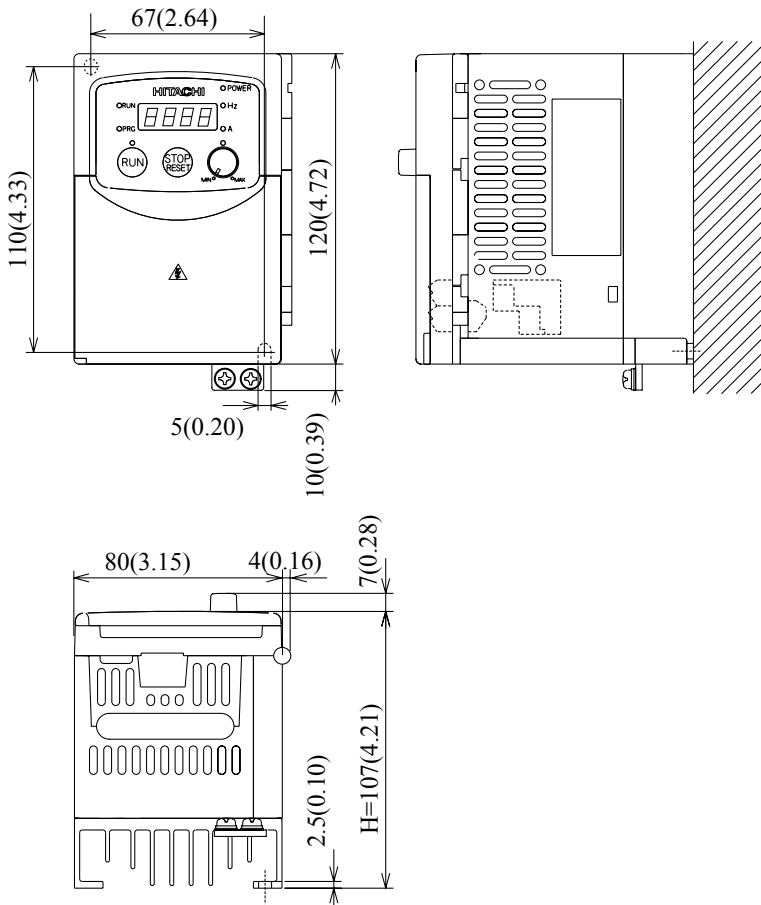

Inverter Mounting and Installation



NOTE: Some inverter housings require two mounting screws, while others require four. Be sure to use lock washers or other means to ensure screws do not loosen due to vibration.

Dimensional drawings, continued...

External Dimensions

- MODEL
- SJ 100 -004HFE
 - 004HFU
 - 007NFE
 - 007NFU
 - 011NFE

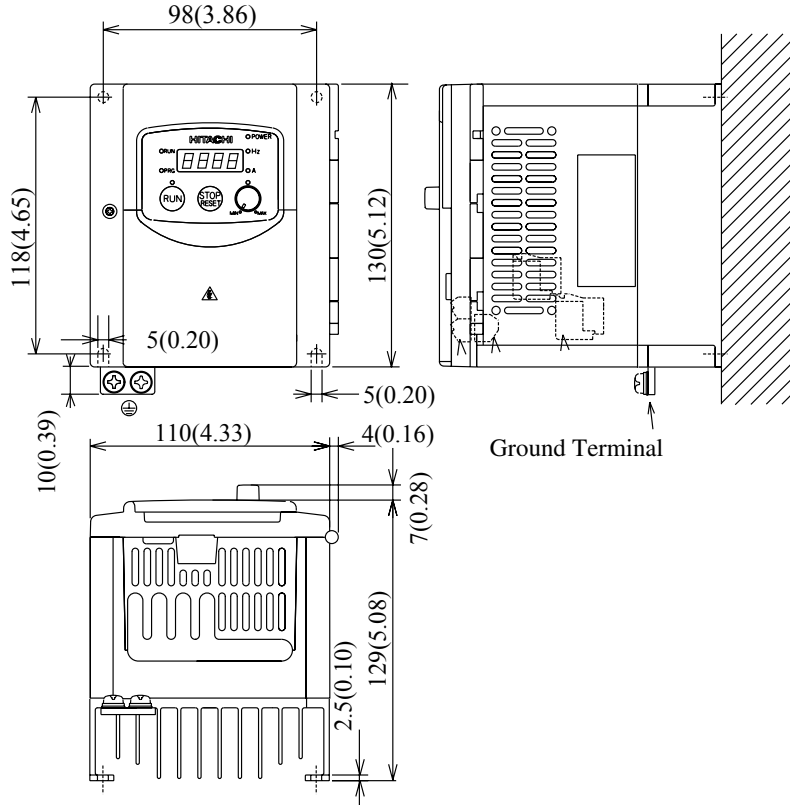

- MODEL
- SJ 100 -007HFE(No fan)
 - 007HFU(No fan)
 - 015HFE
 - 015HFU
 - 022HFE
 - 022HFU

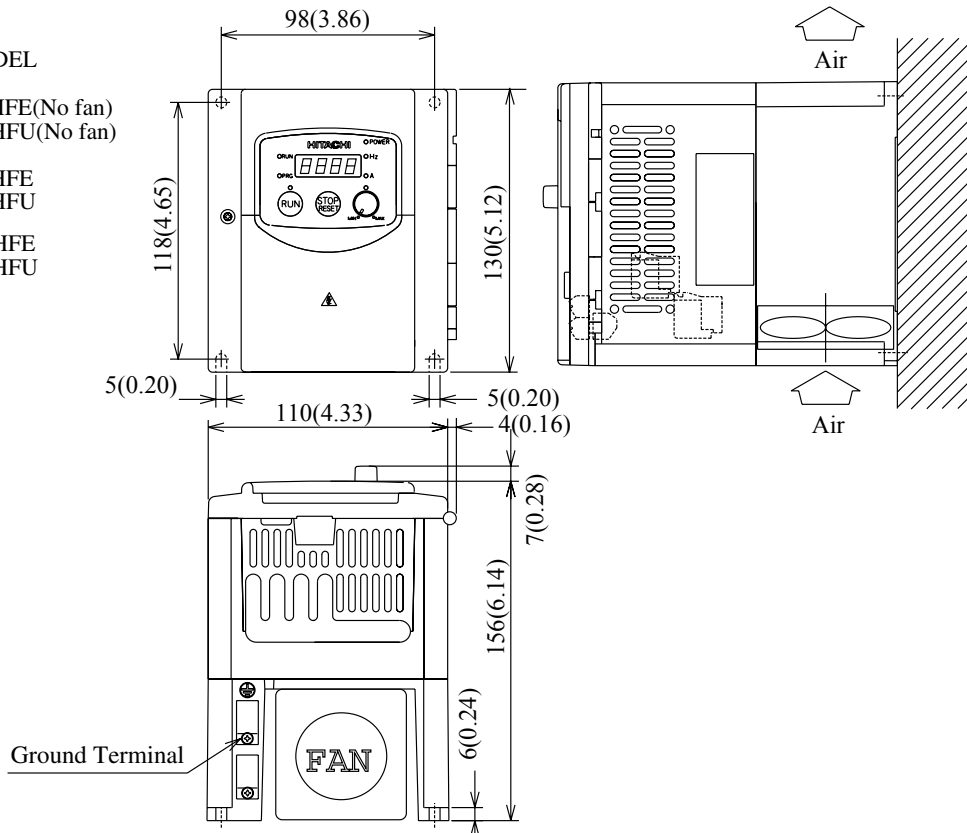

Dimensional drawings, continued...

SJ100 -015NFE
-015NFU

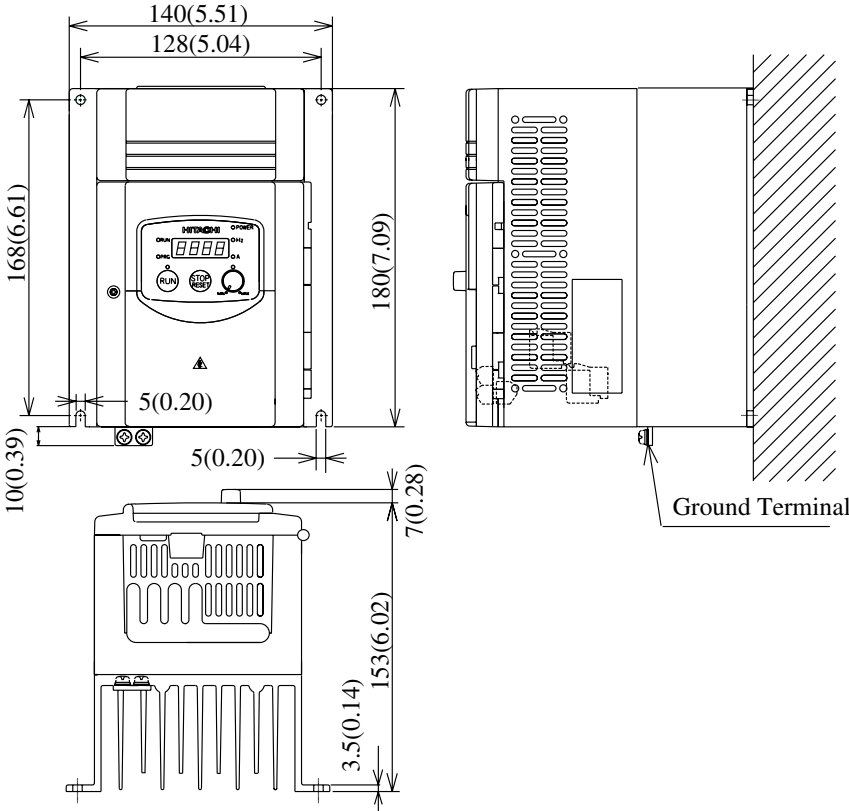

SJ100 -022NFE
-022NFU
-030HFE
-037LFU
-040HFE
-040HFU

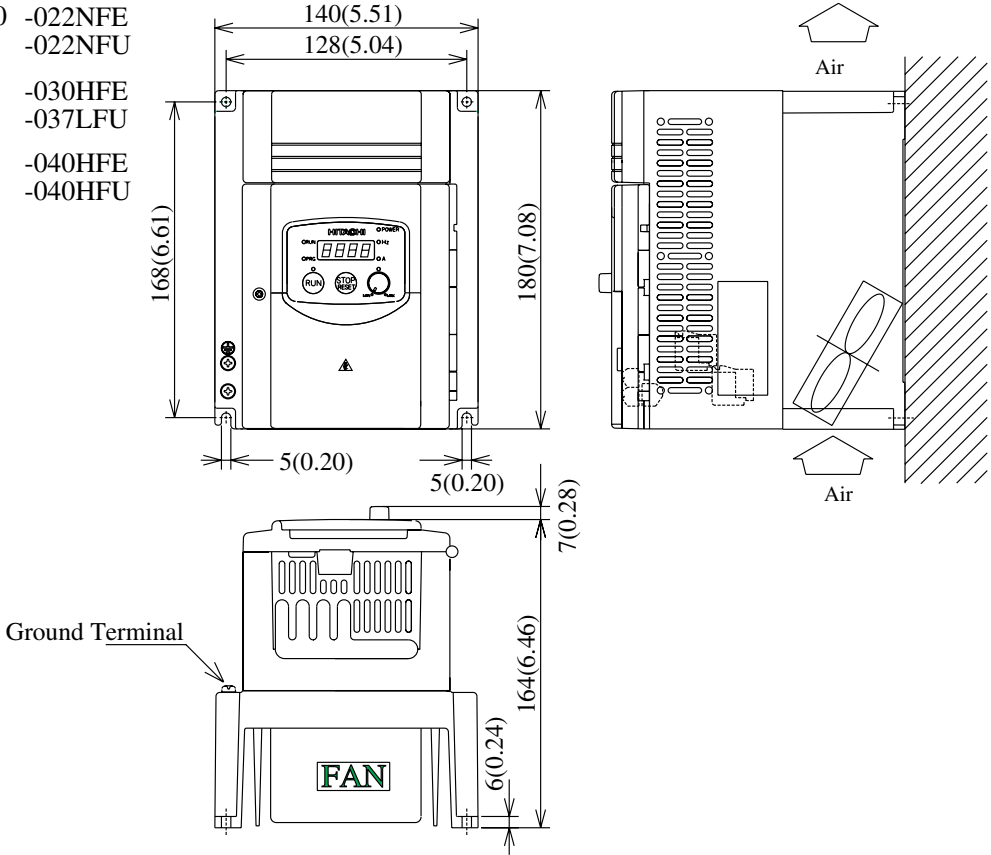

Inverter Mounting
and Installation

Dimensional drawings, continued...

- SJ100 -055LFU
- 055HFE
- 055HFU
- 075LFU
- 075HFE
- 075HFU

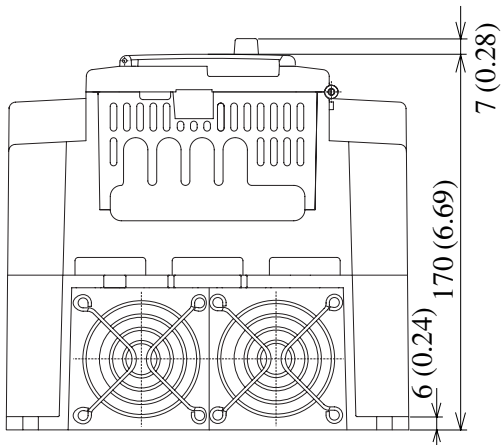
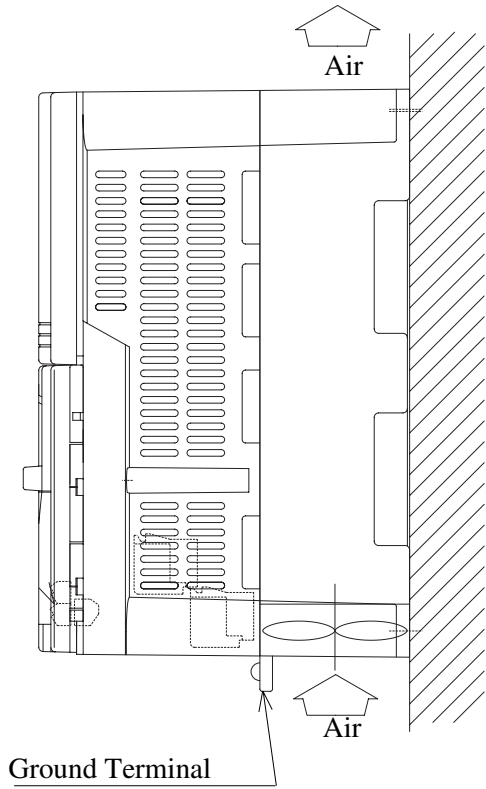
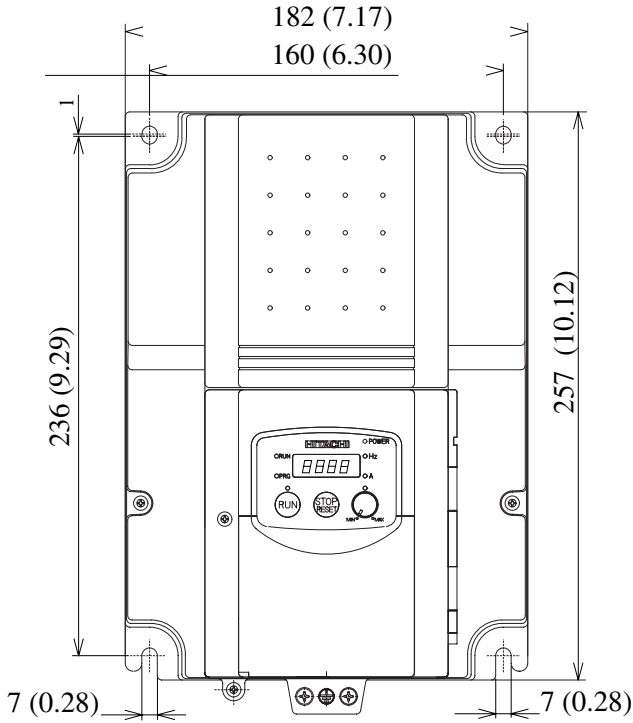

NOTE: Model SJ100-075LFU has (2) fans. All other models in this housing have (1) fan.

Prepare for Wiring



Step 5: It is very important to perform the wiring steps carefully and correctly. Before proceeding, please study the caution and warning messages below.



WARNING: “Use 60/75°C Cu wire only” or equivalent.



WARNING: “Open Type Equipment.”



WARNING: “Suitable for use on a circuit capable of delivering not more than 5,000 rms symmetrical amperes, 240 V maximum.” For models with suffix N or L.



WARNING: “Suitable for use on a circuit capable of delivering not more than 5,000 rms symmetrical amperes, 480 V maximum.” For models with suffix H.



HIGH VOLTAGE: Be sure to ground the unit. Otherwise, there is a danger of electric shock and/or fire.



HIGH VOLTAGE: Wiring work shall be carried out only by qualified personnel. Otherwise, there is a danger of electric shock and/or fire.



HIGH VOLTAGE: Implement wiring after checking that the power supply is OFF. Otherwise, you may incur electric shock and/or fire.



HIGH VOLTAGE: Do not connect wiring to an inverter or operate an inverter that is not mounted according the instructions given in this manual. Otherwise, there is a danger of electric shock and/or injury to personnel.

Determining Wire and Fuse Sizes

The maximum motor currents in your application determines the recommended wire size. The following table gives the wire size in AWG. The “Power Lines” column applies to the inverter input power, output wires to the motor, the earth ground connection, and any other component shown in the [“Basic System Description” on page 2-5](#). The “Signal Lines” column applies to any wire connecting to the two green 8-position connectors just inside the front panel half-door.

Motor Output (kW/HP)		Inverter Model	Wiring		Applicable equipment
kW	HP		Power Lines	Signal Lines	Fuse (UL-rated, class J, 600V)
0.2	1/4	SJ100-002NFE/NFU	AWG16 / 1.3 mm ²	18 to 28 AWG / 0.14 to 0.75 mm ² shielded wire (see Note 4)	10A (single ph.) 7A (three ph.)
0.4	1/2	SJ100-004NFE/NFU			
0.55	3/4	SJ100-005NFE			
0.75	1	SJ100-007NFE/NFU	AWG14 / 2.1 mm ²		15A (single ph.) 10A (three ph.)
1.1	1 1/2	SJ100-011NFE			
1.5	2	SJ100-015NFE/NFU	AWG12 / 3.3 mm ²		20A (single ph.) 15A (three ph.)
2.2	3	SJ100-022NFE/NFU	AWG10 / 5.3 mm ²		30A (single ph.) 20A (three ph.)
3.7	5	SJ100-037LFU	AWG12 / 3.3 mm ²		30A
5.5	7 1/2	SJ100-055LFU	AWG10 / 5.3 mm ²		40A
7.5	10	SJ100-075LFU	AWG8 / 8.4 mm ²		50A
0.4	1/2	SJ100-004HFE/HFU	AWG16 / 1.3 mm ²		3A
0.75	1	SJ100-007HFE/HFU			6A
1.5	2	SJ100-015HFE/HFU			10A
2.2	3	SJ100-022HFE/HFU			
3.0	4	SJ100-030HFE	AWG14 / 2.1 mm ²		15A
4.0	5	SJ100-040HFE/HFU			
5.5	7 1/2	SJ100-055HFE/HFU	AWG12 / 3.3 mm ²	20A	
7.5	10	SJ100-075HFE/HFU		25A	

- Note 1:** Field wiring must be made by a UL-listed and CSA-certified closed-loop terminal connector sized for the wire gauge involved. Connector must be fixed by using the crimping tool specified by the connector manufacturer.
- Note 2:** Be sure to consider the capacity of the circuit breaker to be used.
- Note 3:** Be sure to use a larger wire gauge if power line length exceeds 66 ft (20m).
- Note 4:** Use 18 AWG / 0.75 mm² wire for the alarm signal wire ([AL0], [AL1], [AL2] terminals).

Terminal Dimensions and Torque Specs

The terminal screw dimensions for all SJ100 inverters are listed in table below. This information is useful in sizing spade lug or ring lug connectors for wire terminations.



CAUTION: Fasten the screws with the specified fastening torque in the table below. Check for any loosening of screws. Otherwise, there is the danger of fire.

Connector	Number of Screw Terminals	Models 002NF, 004NF, 005NF		Models 007NF-022NF, 037LE, 004HF - 040HF		Models 055LF, 075LE, 055HF, 075HF	
		Screw Diameter	Width (mm)	Screw Diameter	Width (mm)	Screw Diameter	Width (mm)
Power Terminals	12	M3.5	7.1	M4	9	M5	13
Control Signal	16	M2	—	M2	—	M2	—
Alarm Signal	3	M3	—	M3	—	M3	—
Ground Terminals	2	M4	—	M4	—	M5	—

When connecting wiring, use the tightening torque listed in the following table to safely attach wiring to the connectors.

Screw	Tightening Torque	Screw	Tightening Torque	Screw	Tightening Torque
M2	0.2 N•m (max. 0.25 N•m)	M3.5	0.8 N•m (max. 0.9 N•m)	M5	2.0 N•m (max. 2.2 N•m)
M3	0.5 N•m (max. 0.6 N•m)	M4	1.2 N•m (max. 1.3 N•m)	—	—

Wire the Inverter Input to a Supply

6 **Step 6:** In this step, you will connect wiring to the input of the inverter. First, you must determine whether the inverter model you have requires three-phase power only, or if it can accept either single-phase or three-phase power. All models have the same power connector terminals [L1], [L2], and [N/L3]. **So, you must refer to the specifications label (on the side of the inverter) for the acceptable power source types! For inverters that can accept single-phase power and are connected that way, terminal [L2] will remain unconnected.** The wiring example to the right shows an SJ100 inverter wired for 3-phase input. Note the use of ring lug connectors for a secure connection.

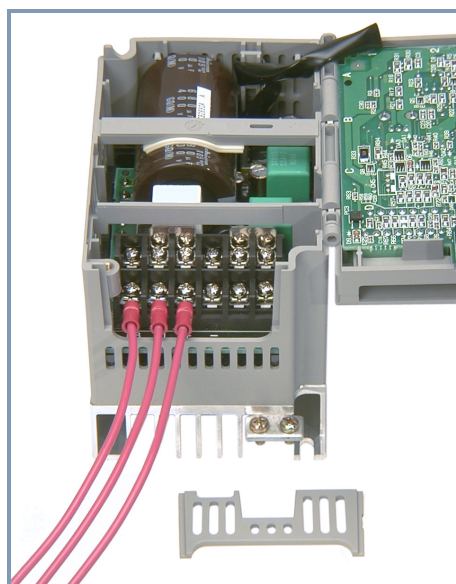

Inverter Mounting and Installation

Please use the terminal arrangement below corresponding to your inverter model.

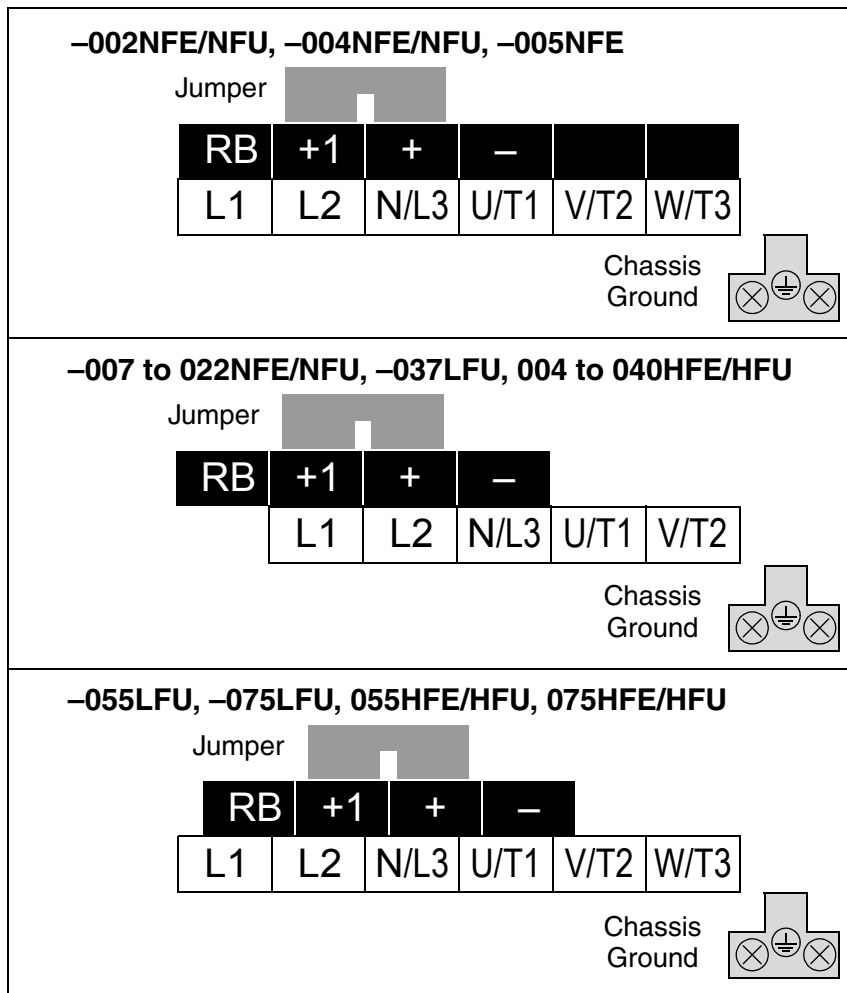

Inverter Mounting and Installation



NOTE: An inverter powered by a portable power generator may receive a distorted power waveform, overheating the generator. In general, the generator capacity should be five times that of the inverter (kVA).



CAUTION: Be sure that the input voltage matches the inverter specifications:

- Single/Three phase 200 to 240 V 50/60 Hz (up to 2.2kW)
- Three phase 200 to 230V 50/60Hz (above 2.2kW)
- Three phase 380 to 460 V 50/60Hz



CAUTION: Be sure not to power a three-phase-only inverter with single phase power. Otherwise, there is the possibility of damage to the inverter and the danger of fire.



CAUTION: Be sure not to connect an AC power supply to the output terminals. Otherwise, there is the possibility of damage to the inverter and the danger of injury and/or fire.

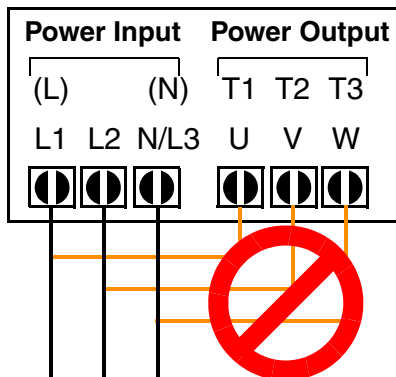

NOTE:

L, N: Single-phase 200 to 240V 50/60 Hz
 L1, L2, L3: Three-phase 200 to 230V 50/60 Hz
 Three-phase 380 to 460V 50/60 Hz



CAUTION: Remarks for using ground fault interrupter breakers in the main power supply:

Adjustable frequency inverters with CE-filters (RFI-filter) and shielded (screened) motor cables have a higher leakage current toward Earth GND. Especially at the moment of switching ON this can cause an inadvertent trip of ground fault interrupters. Because of the rectifier on the input side of the inverter there is the possibility to stall the switch-off function through small amounts of DC current. Please observe the following:

- Use only short time-invariant and pulse current-sensitive ground fault interrupters with higher trigger current.
- Other components should be secured with separate ground fault interrupters.
- Ground fault interrupters in the power input wiring of an inverter are not an absolute protection against electric shock.



CAUTION: Be sure to install a fuse in each phase of the main power supply to the inverter. Otherwise, there is the danger of fire.



CAUTION: For motor leads, ground fault interrupter breakers and electromagnetic contactors, be sure to size these components properly (each must have the capacity for rated current and voltage). Otherwise, there is the danger of fire.

Wire the Inverter Output to Motor

7

Step 7: The process of motor selection is beyond the scope of this manual. However, it must be an AC induction motor with three phases. It should also come with a chassis ground lug. If the motor does not have three power input leads, stop the installation and verify the motor type. Other guidelines for wiring the motor include:

- Use an inverter-grade motor for maximum motor life (1600V insulation).
- For standard motors, use the AC reactor accessory if the wiring between the inverter and motor exceeds 10 meters in length.

Simply connect the motor to the terminals [U/T1], [V/T2], and [W/T3] as shown to the right. This is a good time to connect the chassis ground lug on the drive as well. The motor chassis ground must also connect to the same point. Use a star ground (single-point) arrangement, and never daisy-chain the grounds (point-to-point).

Use the same wire gauge on the motor and chassis ground wiring as you used on the power input wiring in the previous step. After completing the wiring:

- Check the mechanical integrity of each wire crimp and terminal connection.
- Replace the housing partition that covers access to the power connections.
- Close the main door and secure the retention screw firmly.

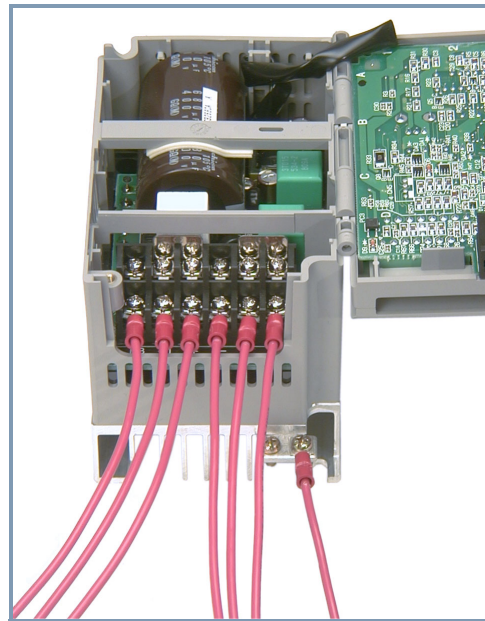

To Power Supply To Motor To Chassis Ground

Logic Control Wiring

After completing the initial installation and powerup test in this chapter, you may need to wire the logic signal connector for your application. For new inverter users/applications, we highly recommend that you first complete the powerup test in this chapter without adding any logic control wiring. Then you will be ready to set the required parameters for logic control as covered in Chapter 4, Operations and Monitoring.

Uncover the Inverter Vents

8

Step 8: After mounting and wiring the inverter, remove any covers from the inverter housing. This includes material over the side ventilation ports. Remove the square cover panel at the top of the housing.



WARNING: Make sure the input power to the inverter is OFF. If the drive has been powered, leave it OFF for five minutes before continuing.



The top housing cover is held in place by four locking tabs. To remove the cover, squeeze two corners together and push a small screwdriver under one side as shown, while pulling upward. Hold the screwdriver at the angle shown, and **DO NOT** push the screwdriver or any object through ventilation openings and into the inverter.

Powerup Test

9

Step 9: After wiring the inverter and motor, you're ready to do a powerup test. The procedure that follows is designed for the first-time use of the drive. Please verify the following conditions before conducting the powerup test:

- You have followed all the steps in this chapter up to this step.
- The inverter is new, and is securely mounted to a non-flammable vertical surface
- The inverter is connected to a power source and motor.
- No additional wiring of inverter connectors or terminals has been done.
- The power supply is reliable, and the motor is a known working unit, and the motor nameplate ratings match the inverter ratings.
- The motor is securely mounted, and is not connected to any load.

Goals for the Powerup Test

If there are any exceptions to the above conditions at this step, please take a moment to take any measures necessary to reach this basic starting point. The specific goals of this powerup test are:

1. Verify that the wiring to the power supply and motor is correct.
2. Demonstrate that the inverter and motor are generally compatible.
3. Give a brief introduction to the use of the built-in operator keypad.

The powerup test gives you an important starting point to ensure a safe and successful application of the Hitachi inverter. We highly recommend performing this test before proceeding to the other chapters in this manual.

Pre-test and Operational Precautions

The following instructions apply to the powerup test, or to any time the inverter is powered and operating. Please study the following instructions and messages before proceeding with the powerup test.

1. The power supply must have fusing suitable for the load. Check the fuse size chart presented in Step 5, if necessary.
2. Be sure you have access to a disconnect switch for the drive input power if necessary. However, do not turn OFF power during inverter operation unless it is an emergency.
3. Turn the front panel potentiometer to the *MIN* position (fully counter-clockwise).



CAUTION: The heat sink fins will have a high temperature. Be careful not to touch them. Otherwise, there is the danger of getting burned.



CAUTION: The operation of the inverter can be easily changed from low speed to high speed. Be sure to check the capability and limitations of the motor and machine before operating the inverter. Otherwise, there is the danger of injury.



CAUTION: If you operate a motor at a frequency higher than the inverter standard default setting (50Hz/60Hz), be sure to check the motor and machine specifications with the respective manufacturer. Only operate the motor at elevated frequencies after getting their approval. Otherwise, there is the danger of equipment damage and/or injury.



CAUTION: Check the following before and during the powerup test. Otherwise, there is the danger of equipment damage.

- Is the shorting bar between the [+1] and [+] terminals installed? DO NOT power or operate the inverter if the jumper is removed.
- Is the direction of the motor rotation correct?
- Did the inverter trip during acceleration or deceleration?
- Were the rpm and frequency meter readings as expected?
- Were there any abnormal motor vibrations or noise?

Powering the Inverter

If you have followed all the steps, cautions and warnings up to this point, you're ready to apply power. After doing so, the following events should occur:

- The *POWER* LED will illuminate.
- The numeric (7-segment) LEDs will display a test pattern, then stop at *0.0*.
- The *Hz* LED will be ON.

If the motor starts running unexpectedly or any other problem occurs, press the *STOP* key. Only if necessary should you remove power to the inverter as a remedy.



NOTE: If the inverter has been previously powered and programmed, the LEDs (other than the *POWER* LED) may illuminate differently than as indicated above. If necessary, you can initialize all parameters to the factory default settings. See [“Restoring Factory Default Settings” on page 6-8](#).

Using the Front Panel Keypad

Front Panel Introduction

Please take a moment to familiarize yourself with the keypad layout shown in the figure below. These are the visible controls and indicators when the front panel door is closed.

The display is used in programming the inverter's parameters, as well as monitoring specific parameter values during operation. Many functions are applicable only during the initial installation, while others are more useful for maintenance or monitoring.

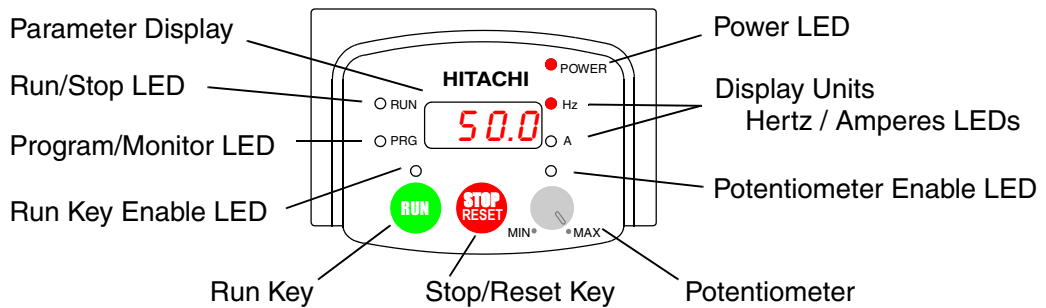

Parameter Editing Controls

Now, open the front panel (half-door) for second-level access to reveal additional operator keys for parameter editing as shown to the right. In normal operation after installation, parameter editing is unnecessary, so these controls are hidden from view. The front panel controls and indicators are described as follows:

- **Run/Stop LED** - ON when the inverter output is ON and the motor is developing torque (Run Mode), and OFF when the inverter output is OFF (Stop Mode).
- **Program/Monitor LED** - This LED is ON when the inverter is ready for parameter editing (Program Mode). It is OFF when the parameter display is monitoring data (Monitor Mode).
- **Run Key Enable LED** - is ON when the inverter is ready to respond to the Run key, OFF when the Run key is disabled.
- **Run Key** - Press this key to run the motor (the Run Enable LED must be ON first). Parameter F_04, Keypad Run Key Routing, determines whether the Run key generates a Run FWD or Run REV command.
- **Stop/Reset Key** - Press this key to stop the motor when it is running (uses the programmed deceleration rate). This key will also reset an alarm that has tripped.
- **Potentiometer** - Allows an operator to directly set the motor speed when the potentiometer is enabled for output frequency control.
- **Potentiometer Enable LED** - ON when the potentiometer is enabled for value entry.

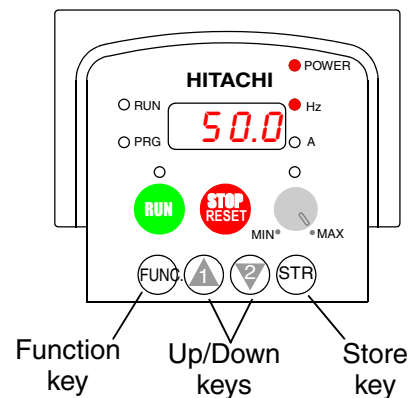

- **Parameter Display** - A 4-digit, 7-segment display for parameters and function codes.
- **Display Units, Hertz/Amperes** - One of these LEDs will be ON to indicate the units associated with the parameter display.
- **Power LED** - This LED is ON when the power input to the inverter is ON.
- **Function Key** - This key is used to navigate through the lists of parameters and functions for setting and monitoring parameter values.
- **Up/Down (\triangle , ∇) Keys** - Use these keys alternately to move up or down the lists of parameter and functions shown in the display, and increment/decrement values.
- **Store (STR) Key** - When the unit is in Program Mode and you have edited a parameter value, press the Store key to write the new value to the EEPROM.

Keys, Modes, and Parameters

Purpose of the keypad is to provide a way to change modes and parameters. The term *function* applies to both monitoring modes and parameters. These are all accessible through *function codes* that are primarily 3-character codes. The various functions are separated into related groups identifiable by the left-most character, as the table shows.

Function Group	Type (Category) of Function	Mode to Access	PGM LED Indicator
“D”	Monitoring functions	Monitor	○
“F”	Main profile parameters	Program	●
“A”	Standard functions	Program	●
“B”	Fine tuning functions	Program	●
“C”	Intelligent terminal functions	Program	●
“H”	Motor constant functions	Program	●
“E”	Error codes	—	—

For example, function “A_04” is the *base frequency setting* for the motor, typically 50 Hz or 60 Hz. To edit the parameter, the inverter must be in Program Mode (PGM LED will be ON). You use the front panel keys to first select the function code “A_04.” After displaying the value for “A_04,” use the Up/Down (\triangle or ∇) keys to edit it.



NOTE: The inverter 7-segment display shows lower case “b” and “d,” meaning the same as the upper case letters “B” and “D” used in this manual (for uniformity “A to F”).

The inverter automatically switches into Monitor Mode when you access “D” Group functions. It switches into Program Mode when you access any other group, because they all have editable parameters. Error codes use the “E” Group, and appear automatically when a fault event occurs. Refer to [“Monitoring Trip Events, History, & Conditions” on page 6-5](#) for error code details.

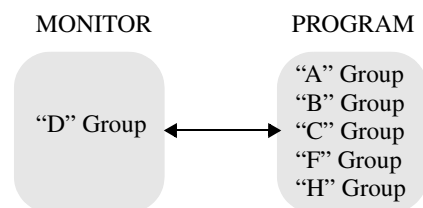

Keypad Navigational Map

The SJ100 Series inverter drives have many programmable functions and parameters. Chapter 3 will cover these in detail, but you need to access just a few items to perform the powerup test. The menu structure makes use of function codes and parameter codes to allow programming and monitoring with only a 4-digit display and a few keys and LEDs. So, it is important to become familiar with the basic navigational map of parameters and functions in the diagram below. You may later use this map as a reference.

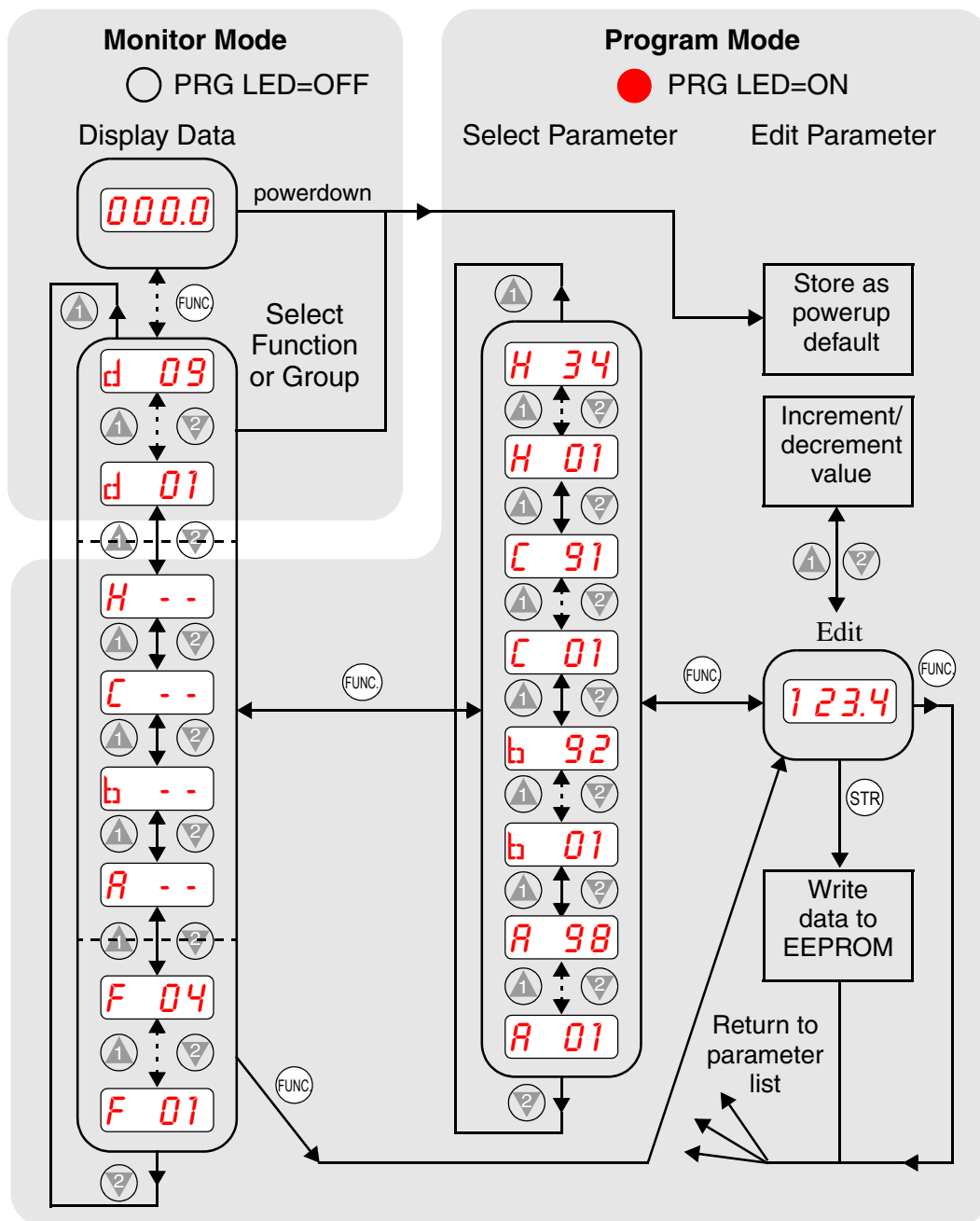

Inverter Mounting and Installation

The navigational map shows the relationship of all resources of the inverter in one view. In general, use the **FUNC.** key to move left and right, and the **▲ ▼** (arrow) keys to move up and down.

Selecting Functions and Editing Parameters

In order to run the motor for the powerup test, this section will show how to:

















- select the inverter's maximum output frequency to the motor
- select the keypad potentiometer as the source of motor speed command
- select the keypad as the source of the RUN command
- set the number of poles for the motor
- enable the RUN command

The following series of programming tables are designed for successive use. Each table uses the previous table's final state as the starting point. Therefore, start with the first and continue programming until the last one. If you get lost or concerned that some of the other parameters settings may be incorrect, refer to [“Restoring Factory Default Settings” on page 6-8](#).

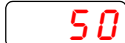



CAUTION: If you operate a motor at a frequency higher than the inverter standard default setting (50Hz/60Hz), be sure to check the motor and machine specifications with the respective manufacturer. Only operate the motor at elevated frequencies after getting their approval. Otherwise, there is the danger of equipment damage.

Setting the Motor Base Frequency -The motor is designed to operate at a specific AC frequency. Most commercial motors are designed for 50/60 Hz operation. First, check the motor specifications. Then follow the steps in the table below to verify the setting or correct for your motor. DO NOT set it for greater than 50/60 Hz unless the motor manufacturer specifically approves operation at the higher frequency.

Action	Display	Func./Parameter
Press the  key.		Monitor functions
Press the  or  keys until ->		“A” Group selected
Press the  key.		First “A” parameter
Press the  key twice.		Base frequency setting
Press the  key.	 or 	Default value for base frequency. US = 60 Hz, Europe = 50 Hz.
Press the  or  key as needed.		Set to your motor specs (your display may be different)
Press the  key.		Stores parameter, returns to “A” Group list











TIP: If you need to scroll through a function or parameter list, press and hold the  or  key to auto-increment through the list.

Select the Potentiometer for Speed Command - The motor speed may be controlled from the following sources:









- Potentiometer on front panel keypad
- Control terminals
- Remote panel

Then follow the steps in the table below to select the potentiometer for the speed command (the table resumes action from the end of the previous table).

Action	Display	Func./Parameter
Press the  key twice.		Speed command source setting
Press the  key.		0 = potentiometer 1 = control terminals (default) 2 = keypad
Press the  key.		0 = potentiometer (selected)
Press the  key.		Stores parameter, returns to “A” Group list

Inverter Mounting and Installation

Select the Keypad for the RUN Command - The RUN command causes the inverter to accelerate the motor to the selected speed. You can program the inverter to respond to either the control terminal signal or the keypad RUN key. Follow the steps in the table below to select the front panel RUN key as the source for the RUN Command (the table resumes action from the end of the previous table).













Action	Display	Func./Parameter
Press the  key.		Run command source
Press the  key.		1 = control terminals (default) 2 = keypad
Press the  key.		2 = keypad (selected)
Press the  key.		Stores parameter, returns to “A” Group list

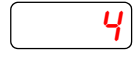

NOTE: When you press the STR key in the last step above (and the display = 02), the Run Enable LED above the RUN switch on the keypad will turn ON. This is normal, and does not mean the motor is trying to run. It means that the RUN key is now enabled. DO NOT press the RUN key at this time—finish out the programming exercise first.

Configure the Inverter for the Number of Motor Poles- The number of magnetic poles of a motor is determined by the motor's internal winding arrangement. The specifications label on the motor usually indicates its number of poles. For proper operation, verify the parameter setting matches the motor poles. Many industrial motors have four poles, corresponding to the default setting in the inverter.

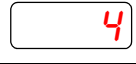
Follow the steps in the table below to verify the motor poles setting and change it if necessary (the table resumes action from the end of the previous table.)

Action	Display	Func./Parameter
Press the  key.		"A" Group selected
Press the  key three times.		"H" Group selected
Press the  key.		First "H" parameter
Press the  key three times.		Motor poles parameter
Press the  key.		2 = 2 poles 4 = 4 poles (default) 6 = 6 poles 8 = 8 poles
Press the  or  key as needed.		Set to match your motor (your display may be different)
Press the  key.		Stores parameter, returns to "H" Group list

This step concludes the parameter setups for the inverter. You are almost ready to run the motor for the first time!



TIP: If you became lost during any of these steps, first observe the state of the PRG LED. Then study the ["Keypad Navigational Map" on page 2-23](#) to determine the current state of the keypad controls and display. As long as you do not press the STR key, no parameters will be changed by keypad entry errors. Note that power cycling the inverter will not cause it to reset to a particular programming state.

The next section will show you how to monitor a particular parameter from the display. Then you will be ready to run the motor.

Monitoring Parameters with the Display

After using the keypad for parameter editing, it's a good idea to switch the inverter from Program Mode to Monitor Mode and close the panel door (puts the keys for parameter editing out of sight). This will also turn out the PRG LED, and the Hertz or Ampere LED indicates the display units.

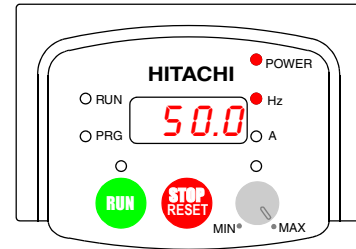

For the powerup test, monitor the motor speed indirectly by viewing the inverter's output frequency. The *output frequency* must not be confused with *base frequency* (50/60 Hz) of the motor, or the *carrier frequency* (switching frequency of the inverter, in the kHz range). The monitoring functions are in the "D" list, located near the top left of the ["Keypad Navigational Map" on page 2-23](#).

Output frequency (speed) monitor - Resuming the keypad programming from the previous table, follow the steps in the table below.

Action	Display	Func./Parameter
Press the key.		"H" Group selected
Press the key.		Output frequency selected
Press the key.		Output frequency displayed

When the function code appeared, the PRG LED went OFF. This confirms the inverter is no longer in programming mode, even while you are selecting the particular monitoring parameter. After pressing the Function key, the display shows the current speed (is zero at this point).

Running the Motor

If you have programmed all the parameters up to this point, you're ready to run the motor! First, review this checklist:

1. Verify the Power LED is ON. If not, check the power connections.
2. Verify the Run Key Enable LED is ON. If not, review the programming steps to find the problem.
3. Verify the PRG LED is OFF. If it is ON, review the instructions above.
4. Make sure the motor is disconnected from any mechanical load.
5. Turn the potentiometer to the MIN position (completely counterclockwise).
6. Now, press the RUN key on the keypad. The RUN LED will turn ON.
7. Slowly increase the potentiometer setting in clockwise fashion. The motor should start turning when the indicator is in the 9:00 position and beyond.
8. Press the STOP key to stop the motor rotation.

Powerup Test Observations and Summary



Step 10: Reading this section will help you make some useful observations when first running the motor.

Error Codes - If the inverter displays an error code (format is “*EXX*”), see [“Monitoring Trip Events, History, & Conditions” on page 6-5](#) to interpret and clear the error.

Acceleration and Deceleration - The SJ100 inverter has programmable acceleration and deceleration values. The test procedure left these at the default value, 10 seconds. You can observe this by setting the potentiometer at about half speed before running the motor. Then press RUN, and the motor will take 5 seconds to reach a steady speed. Press the STOP key to see a 5 second deceleration to a stop.

State of Inverter at Stop - If you adjust the motor’s speed to zero, the motor will slow to a near stop, and the inverter turns the outputs OFF. The high-performance SJ100 can rotate at a very slow speed with high torque output, but not zero (must use servo systems with position feedback for that feature). This characteristic means you must use a mechanical brake for some applications.

Interpreting the Display - First, refer to the output frequency display readout. The maximum frequency setting (parameter A_04) defaults to 50 Hz or 60 Hz (Europe and United States, respectively) for your application.

Example: Suppose a 4-pole motor is rated for 60 Hz operation, so the inverter is configured to output 60 Hz at full scale. Use the following formula to calculate the RPM.

$$\text{Speed in RPM} = \frac{\text{Frequency} \times 60}{\text{Pairs of poles}} = \frac{\text{Frequency} \times 120}{\# \text{ of poles}} = \frac{60 \times 120}{4} = 1800\text{RPM}$$

The theoretical speed for the motor is 1800 RPM (speed of torque vector rotation). However, the motor cannot generate torque unless its shaft turns at a slightly different speed. This difference is called *slip*. So it’s common to see a rated speed of approximately 1750 RPM on a 60 Hz, 4-pole motor. Using a tachometer to measure shaft speed, you can see the difference between the inverter output frequency and the actual motor speed. The slip increases slightly as the motor’s load increases. This is why the inverter output value is called “frequency,” since it is not exactly equal to motor speed. You can program the inverter to display output frequency in units more directly related to the load speed by entering a constant (discussed more in depth on page [3-30](#)).

Run/Stop Versus Monitor/Program Modes –

The Run LED on the inverter is ON in Run Mode, and OFF in Stop Mode. The Program LED is ON when the inverter is in Program Mode, and OFF for Monitor Mode. All four mode combinations are possible. The diagram to the right depicts the modes and the mode transitions via keypad.

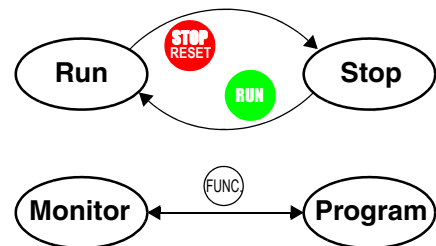

NOTE: Some factory automation devices such as PLCs have alternate Run/Program modes; the device is in either one mode or the other. In the Hitachi inverter, however, Run Mode alternates with Stop Mode, and Program Mode alternates with Monitor Mode. This arrangement lets you program some values while the inverter is operating—providing flexibility for maintenance personnel.

Configuring Drive Parameters



3

In This Chapter....	page
— Choosing a Programming Device	2
— Using Keypad Devices	3
— “D” Group: Monitoring Functions	6
— “F” Group: Main Profile Parameters	8
— “A” Group: Standard Functions	9
— “B” Group: Fine Tuning Functions	24
— “C” Group: Intelligent Terminal Functions	34
— “H” Group: Motor Constants Functions	43

Choosing a Programming Device

Introduction

Hitachi variable frequency drives (inverters) use the latest electronics technology for getting the right AC waveform to the motor at the right time. The benefits are many, including energy savings and higher machine output or productivity. The flexibility required to handle a broad range of applications has required ever more configurable options and parameters—inverters are now a complex industrial automation component. And this can make a product seem difficult to use, but the goal of this chapter is to make this easier for you.

As the powerup test in Chapter 2 demonstrated, you do not have to program very many parameters to run the motor. In fact, most applications would benefit only from programming just a few, specific parameters. This chapter will explain the purpose of each set of parameters, and help you choose the ones that are important to your application.

If you are developing a new application for the inverter and a motor, finding the right parameters to change is mostly an exercise in optimization. Therefore, it is okay to begin running the motor with a loosely tuned system. By making specific, individual changes and observing their effects, you can achieve a finely tuned system. And, the SJ100 Series inverters have a built-in auto-tuning algorithm to set certain motor parameters.

Introduction to Inverter Programming

The front panel keypad is the first and best way to get to know the inverter's capabilities. Every function or programmable parameter is accessible from the keypad. The other devices simply imitate the keypad's layout and inverter access, while adding another valuable aspect to the system. For example, the Copy Unit can transfer one inverter's parameter settings to another inverter, while still providing standard operator keypad control. In this way, you can use a variety of programming devices with basically the same keypad skills. The following table shows various programming options, the features unique to each device, and the cables required.

Device	Part Number	Parameter Access	Parameter setting storage	Cables (choose one)	
				Part number	Length
Inverter keypad	—	Monitor and program	EEPROM in inverter	—	—
DOP Professional Software (for PC)	DOP-PRO	Monitor and program	PC hard drive or diskette	(Included with software)	2 meters
Digital Operator/ Copy Unit	SRW-0EX	Monitor and program	EEPROM in operator panel	ICS-1	1 meter
				ICS-3	3 meters
Operator Monitor	OPE-J	Monitor only	none on operator monitor	ICJ-1L	1 meter
				ICJ-3L	3 meters

Using Keypad Devices

Inverter Front Panel Keypad

The SJ100 Series inverter front keypad contains all the elements for both monitoring and programming parameters. The keypad layout is pictured below. All other programming devices for the inverter have a similar key arrangement and function.

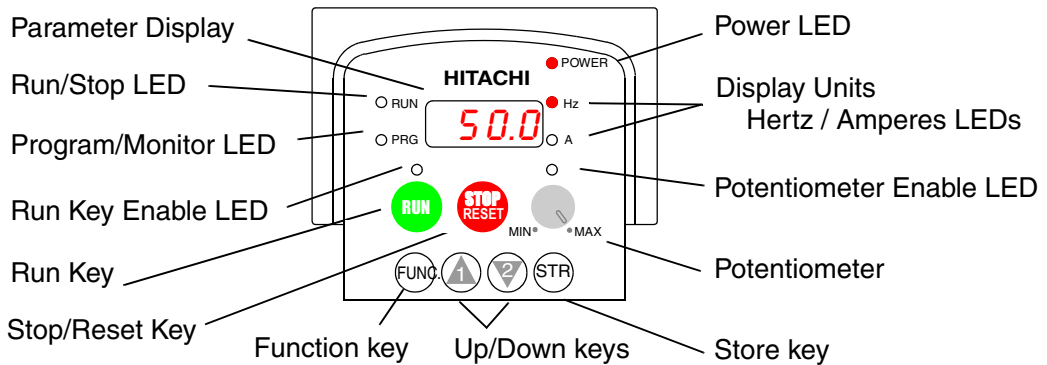

Key and Indicator Legend

- **Run/Stop LED** - ON when the inverter output is ON and the motor is developing torque (Run Mode), and OFF when the inverter output is OFF (Stop Mode).
- **Program/Monitor LED** - This LED is ON when the inverter is ready for parameter editing (Program Mode). It is OFF when the parameter display is monitoring data (Monitor Mode).
- **Run Key Enable LED** - is ON when the inverter is ready to respond to the Run key, OFF when the Run key is disabled.
- **Run Key** - Press this key to run the motor (the Run Enable LED must be ON first). Parameter F_04, Keypad Run Key Routing, determines whether the Run key generates a Run FWD or Run REV command.
- **Stop/Reset Key** - Press this key to stop the motor when it is running (uses the programmed deceleration rate). This key will also reset an alarm that has tripped.
- **Potentiometer** - Allows an operator to directly set the motor speed when the potentiometer is enabled for output frequency control.
- **Potentiometer Enable LED** - ON when the potentiometer is enabled for value entry.
- **Parameter Display** - A 4-digit, 7-segment display for parameters and function codes.
- **Display Units, Hertz/Amperes** - One of these LEDs will be ON to indicate the units associated with the parameter display.
- **Power LED** - This LED is ON when the power input to the inverter is ON.
- **Function Key** - This key is used to navigate through the lists of parameters and functions for setting and monitoring parameter values.
- **Up/Down (\triangle , ∇) Keys** - Use these keys alternately to move up or down the lists of parameter and functions shown in the display, and increment/decrement values.
- **Store ($\text{\textcircled{STR}}$) Key** - When the unit is in Program Mode and you have edited a parameter value, press the Store key to write the new value to the EEPROM.

Keypad Navigational Map

You can use the inverter’s front panel keypad to navigate to any parameter or function. The diagram below shows the basic navigational map to access these items.

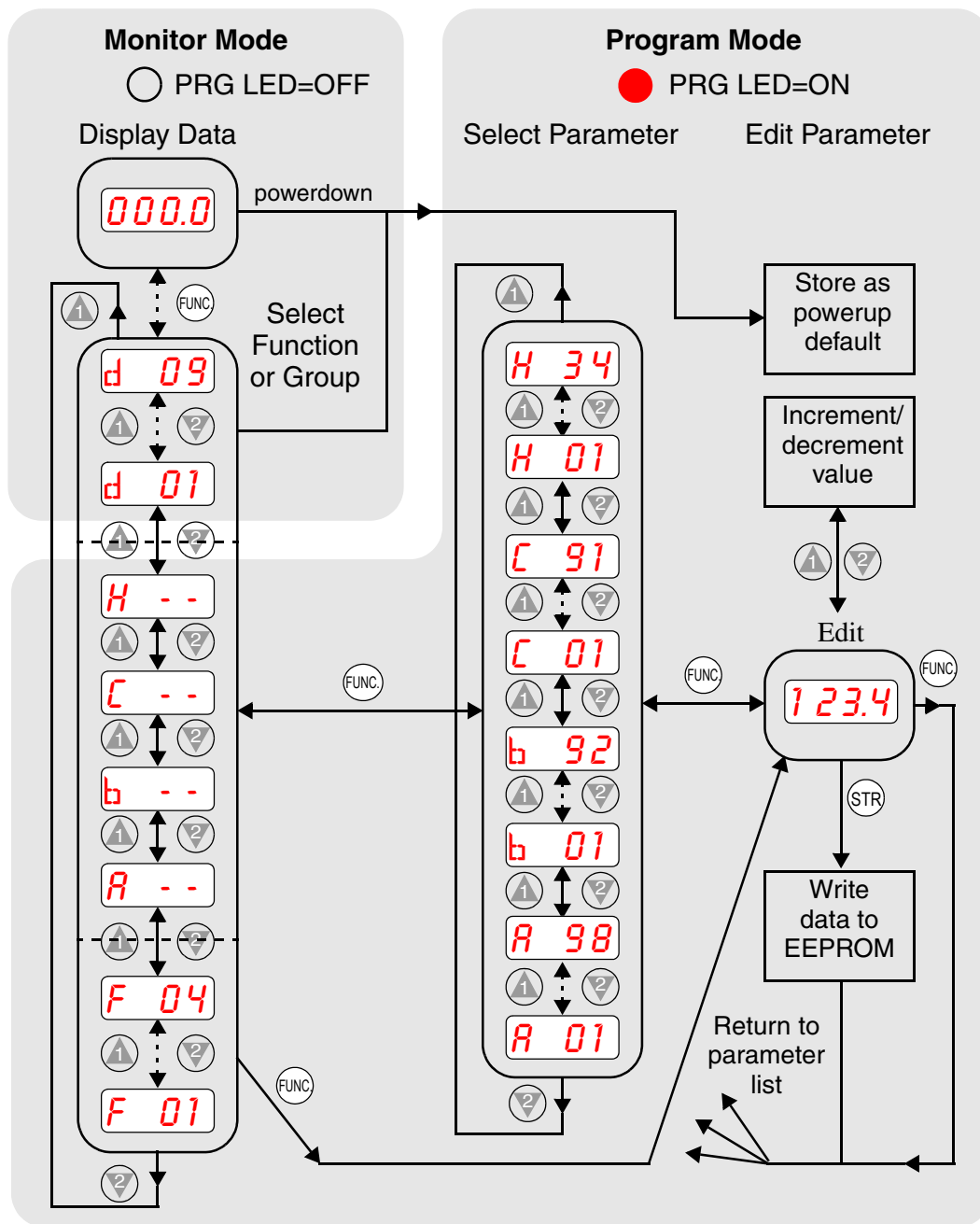

Configuring Drive Parameters



NOTE: The inverter 7-segment display shows lower case “b” and “d,” meaning the same as the upper case letters “B” and “D” used in this manual (for uniformity “A to F”).



NOTE: The Store Key saves the edited parameter (shown in the display) to the inverter’s EEPROM. Upload or download of parameters to/from external devices is accomplished through a different command—do not confuse *Store* with *Download* or *Upload*.

Operational Modes

The RUN and PGM LEDs tell just part of the story; Run Mode and Program Modes are independent modes, not opposite modes. In the state diagram to the right, Run alternates with Stop, and Program Mode alternates with Monitor Mode. This is a very important ability, for it shows that a technician can approach a running machine and change some parameters without shutting down the machine.

The occurrence of a fault during operation will cause the inverter to enter the Trip Mode as shown. An event such as an output overload will cause the inverter to exit the Run Mode and turn OFF its output to the motor. In the Trip Mode, any request to run the motor is ignored. You must clear the error by pressing the Stop/Reset switch. See [“Monitoring Trip Events, History, & Conditions” on page 6-5.](#)

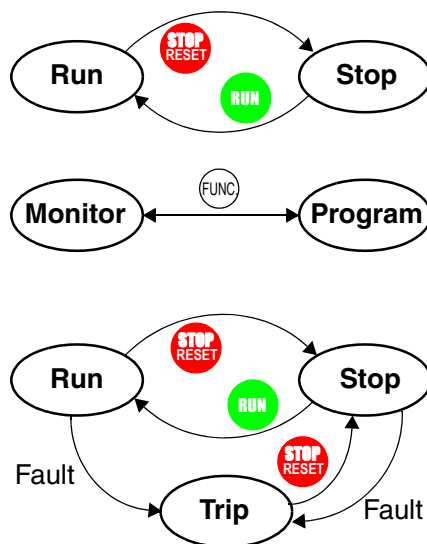

Run Mode Edits

The inverter can be in Run Mode (inverter output is controlling motor) and still allow you to edit certain parameters. This is useful in applications that must run continuously, yet need some inverter parameter adjustment.

The parameter tables in this chapter have a column titled “Run Mode Edit.” An Ex mark ✘ means the parameter cannot be edited; a Check mark ✔ means the parameter can be edited. The Software Lock Setting (parameter B_31) determines when the Run Mode access permission is in effect and access permission in other conditions, as well. It is the responsibility of the user to choose a useful and safe software lock setting for the inverter operating conditions and personnel. Please refer to [“Software Lock Mode” on page 3-28](#) for more information.

	Run Mode Edit	
	✘	
	✔	

Configuring Drive Parameters

Control Algorithms

The motor control program in the SJ100 inverter has three sinusoidal PWM switching algorithms. The intent is that you select the best algorithm for the motor characteristics in your application. Each algorithm generates the frequency output in a unique way. Once configured, the algorithm is the basis for other parameter settings as well (see [“Torque Control Algorithms” on page 3-13](#)). Therefore, choose the best algorithm early in your application design process.

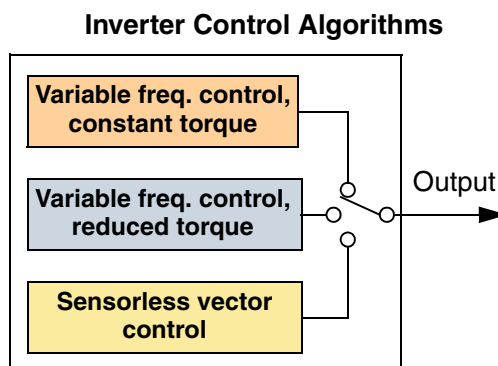

“D” Group: Monitoring Functions

Parameter Monitoring Functions

You can access important system parameter values with the “D” Group monitoring functions, whether the inverter is in Run Mode or Stop Mode. After selecting the function code number for the parameter you want to monitor, press the Function key once to show the value on the display. In Functions D_05 and D_06, the intelligent terminals use individual segments of the display to show ON/OFF status.

If the inverter display is set to monitor a parameter and powerdown occurs, the inverter stores the present monitor function setting. For your convenience, the display automatically returns to the previously monitored parameter upon the next powerup.

Configuring Drive Parameters

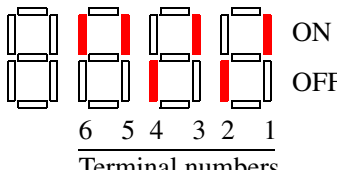
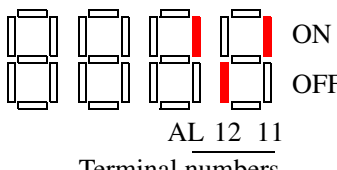
“D” Function			Run Mode Edit	Range and Units
Func. Code	Name / SRW Display	Description		
D_01	Output frequency monitor	Real-time display of output frequency to motor, from 0.0 to 360.0 Hz	—	0.0 to 360.0 Hz
	FM 0000.00Hz			
D_02	Output current monitor	Filtered display of output current to motor (100 ms internal filter time constant)	—	A
	Im 0.0A 0.0%			
D_03	Rotation direction monitor	Three different indications: “F”..... Forward “l l” .. Stop “r”..... Reverse	—	—
	Dir STOP			
D_04	Process variable (PV), PID feedback monitor	Displays the scaled PID process variable (feedback) value (A_75 is scale factor)	—	—
	PID-FB 0000.00%			
D_05	Intelligent input terminal status	Displays the state of the intelligent input terminals: 	—	—
	TERM LLL LLLLLL			
D_06	Intelligent output terminal status	Displays the state of the intelligent output terminals: 	—	—
	TERM LLL LLLLLL			

“D” Function			Run Mode Edit	Range and Units
Func. Code	Name / SRW Display	Description		
D_07	Scaled output frequency monitor	Displays the output frequency scaled by the constant in B_86. Decimal point indicates range: XX.XX 0.01 to 99.99 XXX.X 100.0 to 999.9 XXXX. 1000 to 9999 XXXXX 10000 to 99990	—	Hz
	/Hz01.0 0.00			

Trip Event and History Monitoring

The trip event and history monitoring feature lets you cycle through related information using the keypad. See [“Monitoring Trip Events, History, & Conditions” on page 6-5](#) for more details.

“D” Function			Run Mode Edit	Range and Units
Func. Code	Name / SRW Display	Description		
D_08	Trip event monitor	Displays the current trip event information.	—	—
	ERR1 EEPROM			
	ERR1 0.0Hz			
	ERR1 0.0A			
	ERR1 324.3Vdc ERR1 RUN 000000H			
D_09	Trip history monitor	Displays the previous two events and their causes.	—	—
	ERR2 EEPROM			
	ERR2 0.0Hz			
	ERR2 0.0A			
	ERR2 330.0Vdc ERR2 RUN 000000H			
	ERR3 EEPROM			
	ERR3 0.0Hz			
	ERR3 0.0A			
	ERR3 328.7Vdc ERR3 RUN 000000H			
	—			
RUN 000000H				
—	Trip count	Displays cumulative number of trip events.	—	trips
	ERROR COUNT 009			

“F” Group: Main Profile Parameters

The basic frequency (speed) profile is defined by parameters contained in the “F” Group as shown to the right. The set running frequency is in Hz, but acceleration and deceleration are specified in the time duration of the ramp (from zero to maximum frequency, or from maximum frequency to zero). The motor direction

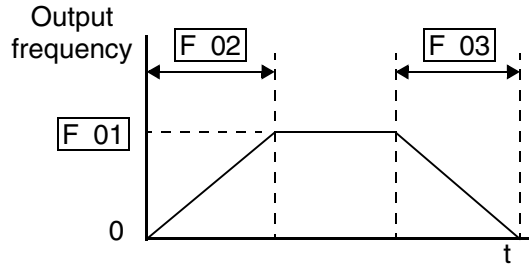

Run key produces a FWD or REV command. This parameter does not affect the intelligent terminal [FWD] and [REV] functions, which you configure separately.

Acceleration 1 and Deceleration 1 are the standard default accel and decel values for the main profile. Accel and decel values for an alternative profile are specified by using parameters Ax92 through Ax93. The motor direction selection (F_04) determines the direction of rotation as commanded only from the keypad. This setting applies to any motor profile (1st or 2nd) in use at a particular time

Configuring Drive Parameters

“F” Function			Run Mode Edit	Defaults			Units
Func. Code	Name / SRW Display	Description		-FE (CE)	-FU (UL)	-FR (Jpn)	
F_01	Output frequency setting	Standard default target frequency that determines constant motor speed, range is 0 to 360 Hz	✓	0.0	0.0	0.0	Hz
	TM 000.0 0.0Hz						
F_02	Acceleration (1) time setting	Standard default acceleration, range is 0.1 to 3000 sec.	✓	10.0	10.0	10.0	sec.
	ACC 1 0010.0s						
F202	Acceleration (1) time setting, 2nd motor	Standard default acceleration, 2nd motor, range is 0.1 to 3000 sec.	✓	10.0	10.0	10.0	sec.
	2ACC1 0010.0s						
F_03	Deceleration (1) time setting	Standard default deceleration, range is 0.1 to 3000 sec.	✓	10.0	10.0	10.0	sec.
	DEC 1 0010.0s						
F203	Deceleration (1) time setting, 2nd motor	Standard default deceleration, 2nd motor, range is 0.1 to 3000 sec.	✓	10.0	10.0	10.0	sec.
	2DEC1 0010.0s						
F_04	Keypad Run key routing	Two options; select codes: 00... Forward 01... Reverse	✗	00	00	00	—
	INIT DOPE FWD						

“A” Group: Standard Functions

Basic Parameter Settings

These settings affect the most fundamental behavior of the inverter—the outputs to the motor. The frequency of the inverter’s AC output determines the motor speed. You may select from three different sources for the reference speed. During application development you may prefer using the potentiometer, but you may switch to an external source (control terminal setting) in the finished application, for example.

The base frequency and maximum frequency settings interact according to the graph below (left). The inverter output operation follows the constant V/f curve until it reaches the full-scale output voltage. This initial straight line is the constant-torque part of the operating characteristic. The horizontal line over to the maximum frequency serves to let the motor run faster, but at a reduced torque. If you want the motor to output constant torque over its entire operating range (limited to the motor nameplate voltage and frequency rating), then set the base frequency and maximum frequency equal as shown (below right).

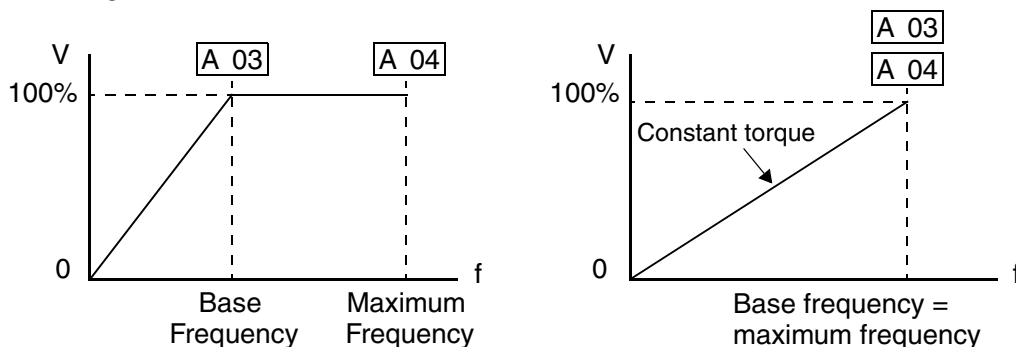

NOTE: The “2nd motor” settings in the tables in this chapter store an alternate set of parameters for a second motor. The inverter can use the 1st set or 2nd set of parameters to generate the output frequency to the motor. See [“Configuring the Inverter for Multiple Motors” on page 4-40.](#)

“A” Function			Run Mode Edit	Defaults			
Func. Code	Name / SRW Display	Description		-FE (CE)	-FU (UL)	-FR (Jpn)	Units
A_01	Frequency source setting	Three options; select codes: 00... Keypad potentiometer 01... Control terminal 02... Function F_01 setting	✘	01	01	02	—
	F-SET-SELECT TRM						
A_02	Run command source setting	Two options; select codes: 01... Control terminal 02... Run key on keypad, or digital operator	✘	01	01	02	—
	F/R SELECT TRM						
A_03	Base frequency setting	Settable from 50 Hz to the maximum frequency	✘	50.0	60.0	60.0	Hz
	F-BASE 060Hz						

"A" Function			Run Mode Edit	Defaults			
Func. Code	Name / SRW Display	Description		-FE (CE)	-FU (UL)	-FR (Jpn)	Units
A203	Base frequency setting, 2nd motor	Settable from 50 Hz to the maximum frequency	✘	50.0	60.0	60.0	Hz
	ZF-BASE						
A_04	Maximum frequency setting	Settable from the base frequency up to 360 Hz	✘	50.0	60.0	60.0	Hz
	F-MAX						
A204	Maximum frequency setting, 2nd motor	Settable from the base frequency up to 360 Hz	✘	50.0	60.0	60.0	Hz
	ZF-MAX						

Analog Input Settings

The inverter has the capability to accept an external analog input that can command the output frequency to the motor. Voltage input (0–10V) and current input (4–20mA) are available on separate terminals ([O] and [OI], respectively). Terminal [L] serves as signal ground for the two analog inputs. The analog input settings adjust the curve characteristics between the analog input and the frequency output.

In the graph below (left), A_13 and A_14 select the active portion of the input voltage or current range. The parameters A_11 and A_12 select the start and end frequency of the converted output frequency range. Together, these four parameters define a line segment as shown (below, right). When the line does not begin at the origin, A_15 defines whether the inverter outputs 0Hz or the A_11 frequency when the analog input value is less than the A_13 setting (determines the non-linear part of the translation).

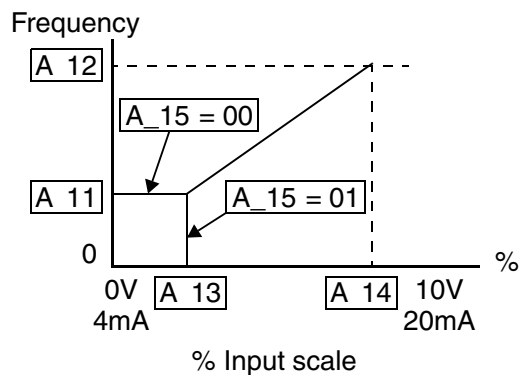
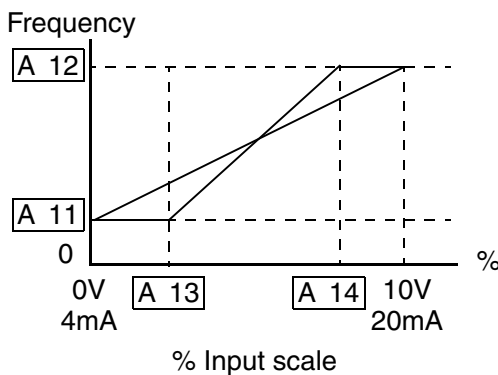

“A” Function			Run Mode Edit	Defaults			
Func. Code	Name / SRW Display	Description		-FE (CE)	-FU (UL)	-FR (Jpn)	Units
A_11	O-L input active range start frequency	The output frequency corresponding to the analog input range starting point	✘	0	0	0	Hz
	IN EXS 000.0Hz						
A_12	O-L input active range end frequency	The output frequency corresponding to the analog input range ending point	✘	0	0	0	Hz
	IN EXE 000.0Hz						
A_13	O-L input active range start voltage	The starting point (offset) for the active analog input range	✘	0	0	0	%
	IN EX%S 000%						
A_14	O-L input active range end voltage	The ending point (offset) for the active analog input range	✘	100	100	100	%
	IN EX%E 100%						
A_15	O-L input start frequency enable	Two options; select codes: 00... Use offset (A_11 value) 01... Use 0 Hz	✘	01	01	01	—
	IN LEVEL 0Hz						
A_16	External frequency filter time constant	Range n = 1 to 8, where n = number of samples for avg.	✘	8	8	8	Sam- ples
	IN F-SAMP 8						

Multi-speed and Jog Frequency Setting

The SJ100 inverter has the capability to store and output up to 16 preset frequencies to the motor (A_20 to A_35). As in traditional motion terminology, we call this *multi-speed profile* capability. These preset frequencies are selected by means of digital inputs to the inverter. The inverter applies the current acceleration or deceleration setting to change from the current output frequency to the new one. The first multi-speed setting is duplicated for the second motor settings (the remaining 15 multi-speeds apply only to the first motor).

The jog speed setting is used whenever the Jog command is active. The jog speed setting range is arbitrarily limited to 10 Hz, to provide safety during manual operation. The acceleration to the jog frequency is instantaneous, but you can choose from three modes for the best method for stopping the jog operation.

"A" Function			Run Mode Edit	Defaults			
Func. Code	Name / SRW Display	Description		-FE (CE)	-FU (UL)	-FR (Jpn)	Units
A_20	Multi-speed frequency setting	Defines the first speed of a multi-speed profile, range is 0 to 360 Hz A_20 = Speed 0 (1st motor)	✓	0	0	0	Hz
	SPD FS 000.0Hz						
A220	Multi-speed frequency setting, 2nd motor	Defines the first speed of a multi-speed profile for 2nd motor, range is 0 to 360 Hz A_20 = Speed 0 (2nd motor)	✓	0	0	0	Hz
	SPD 2FS 000.0Hz						
A_21 to A_35	Multi-speed frequency settings (for both motors)	Defines 15 more speeds, range is 0 to 360 Hz. A_21= Speed 1... A_35 = Speed 15	✓	see next row	see next row	see next row	Hz
	SPD 1 000.0Hz	A_21		0	0	5	
	SPD 2 000.0Hz	A_22		0	0	10	
	SPD 3 000.0Hz	A_23		0	0	15	
	SPD 4 000.0Hz	A_24		0	0	20	
	SPD 5 000.0Hz	A_25		0	0	30	
	SPD 6 000.0Hz	A_26		0	0	40	
	SPD 7 000.0Hz	A_27		0	0	50	
	SPD 8 000.0Hz	A_28		0	0	60	
	SPD 9 000.0Hz	A_29		0	0	0	
	SPD 10 000.0Hz	A_30		0	0	0	
	SPD 11 000.0Hz	A_31		0	0	0	
	SPD 12 000.0Hz	A_32		0	0	0	
	SPD 13 000.0Hz	A_33		0	0	0	
	SPD 14 000.0Hz	A_34		0	0	0	
	SPD 15 000.0Hz	A_35		0	0	0	
	A_38	Jog frequency setting		Defines limited speed for jog, range is 0.5 to 9.99 Hz	✓	1.0	
Jog Freq 01.00Hz							
A_39	Jog stop mode	Define how end of jog stops the motor; three options: 00... Free-run stop 01... Controlled deceleration 02... DC braking to stop	✗	00	00	00	—
	Jog Mode 0						

Torque Control Algorithms

The inverter generates the motor output according to the V/f algorithm or the sensorless vector control algorithm. Parameter A_44 selects the inverter algorithm for generating the frequency output, as shown in the diagram to the right (A244 for 2nd motor). The factory default is 02 (sensorless vector control).

Inverter Torque Control Algorithms

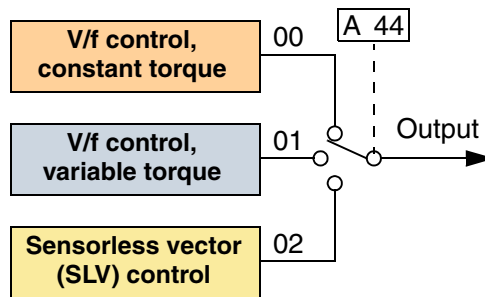

Review the following descriptions to help you choose the best torque control algorithm for your application.

- The built-in V/f curves are oriented toward developing constant torque or variable torque characteristics (see graphs below).
- Sensorless vector control calculates an ideal torque vector based on current motor position, winding currents, and so on. It is a more robust control method than the V/f control methods. However, it is more dependent on actual motor parameters and will require you to set these values carefully or perform the auto-tuning procedure (see [“Auto-tuning for Sensorless Vector Control” on page 4-35](#)).

Constant and Variable (Reduced) Torque – The graph below (left) shows the constant torque characteristic from 0Hz to the base frequency A_03. The voltage remains constant for output frequencies higher than the base frequency. The graph below (right) shows the general variable (reduced) torque curve. The range from 0Hz to the base frequency is the variable characteristic.

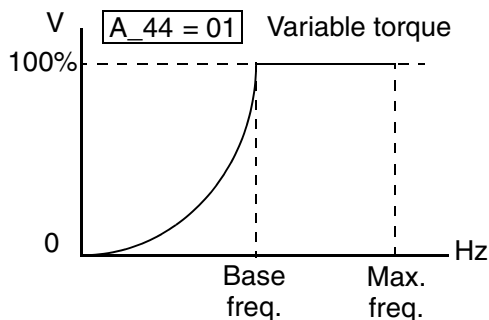
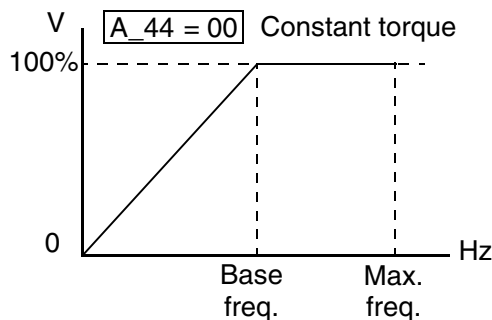

Torque Boost – The Constant and Variable Torque algorithms feature an adjustable *torque boost* curve. When the motor load has a lot of inertia or starting friction, you may need to increase the low frequency starting torque characteristics by boosting the voltage above the normal V/f ratio (shown at right). The boost is applied from zero to 1/2 the base frequency. You set the breakpoint of the boost (point A on the graph) by using

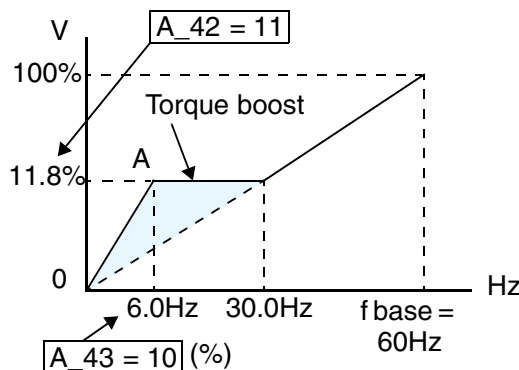

parameters A_42 and A_43. The manual boost is calculated as an addition to the standard straight V/f line (constant torque curve).



NOTE: Manual torque boost is not operational when sensorless vector control is in use.

Be aware that running the motor at a low speed for a long time can cause motor overheating. This is particularly true when manual torque boost is ON, or if the motor relies on a built-in fan for cooling.



NOTE: Manual torque boost applies only to constant torque (A_44=00) and variable torque (A_44=01) V/f control.

Voltage Gain – Using parameter A_45 you can modify the voltage gain of the inverter (see graph at right). This is specified as a percentage of the full scale setting (Automatic Voltage Regulation) AVR level in parameter F_03. The gain can be set from 50% to 100%. It should be adjusted in accordance with the motor specifications.

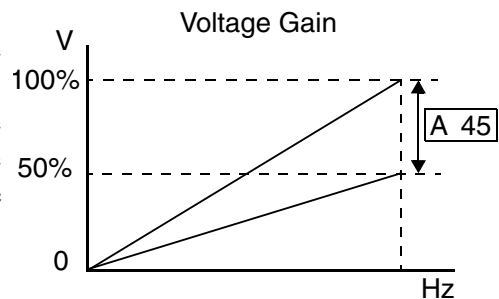

Sensorless Vector Control (SLV) – This advanced torque control algorithm improves torque performance at very low speeds—down to 0.5 Hz. Set parameter A_44=02 to select SLV operation. The SLV algorithm must be tuned to match the characteristics of the particular motor connected to your inverter. Simply using the default motor parameters in the inverter will not work satisfactorily for these control methods. Chapter 4 discusses motor/inverter size selection and how to set the motor parameters either manually or by using the built-in auto-tuning. Before using the sensorless vector control methods, please refer to [“Auto-tuning for Sensorless Vector Control” on page 4-35](#).



NOTE: When the inverter is in SLV (sensorless vector) mode, use B_83 to set the carrier frequency greater than 2.1 kHz for proper operation.



NOTE: You must disable sensorless vector operation when two or more motors are connected (parallel operation) to the inverter.

The following table shows the methods of torque control selection.

“A” Function			Run Mode Edit	Defaults			
Func. Code	Name / SRW Display	Description		-FE (CE)	-FU (UL)	-FR (Jpn)	Units
A_41	Torque boost method selection	Two options: 00... Manual torque boost 01... Automatic torque boost	✗	00	00	00	—
	V-Boost Mode 0						
A241	Torque boost method selection, 2nd motor	Two options (for 2nd motor): 00... Manual torque boost 01... Automatic torque boost	✗	00	00	00	—
	2V-Boost Mode 0						
A_42	Manual torque boost value	Can boost starting torque between 0 and 99% above normal V/f curve, from 0 to 1/2 base frequency	✓	11	11	11	—
	V-Boost code 11						
A242	Manual torque boost value, 2nd motor	Can boost starting torque between 0 and 99% above normal V/f curve, from 0 to 1/2 base frequency	✓	11	11	11	—
	2V-Boost code 11						
A_43	Manual torque boost frequency adjustment	Sets the frequency of the V/f breakpoint A in graph (top of previous page) for torque boost	✓	10.0	10.0	10.0	%
	V-Boost F 10.0%						
A243	Manual torque boost frequency adjustment, 2nd motor	Sets the frequency of the V/f breakpoint A in graph (top of previous page) for torque boost	✓	10.0	10.0	10.0	%
	2V-Boost F 10.0%						
A_44	V/f characteristic curve selection	Two available V/f curves; three select codes: 00... Constant torque 01... Reduced torque 02... Sensorless vector control	✗	02	02	02	—
	CONTROL SLV						
A244	V/f characteristic curve selection, 2nd motor	Two available V/f curves; three select codes: 00... Constant torque 01... Reduced torque 02... Sensorless vector control	✗	02	02	02	—
	2CONTROL SLV						
A_45	V/f gain setting	Sets voltage gain of the inverter from 50 to 100%	✓	100	100	100	%
	V-Gain 100%						

DC Braking Settings

The DC braking feature can provide additional stopping torque when compared to a normal deceleration to a stop. DC braking is particularly useful at low speeds when normal deceleration torque is minimal. When you enable DC braking, the inverter injects a DC voltage into the motor windings during deceleration below a frequency you can specify (A_52). The braking power (A_54) and duration (A_55) can both be set. You can optionally specify a wait time before DC braking (A_53), during which the motor will free run (coast).

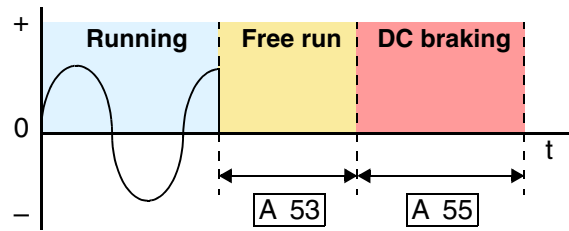

CAUTION: Be careful to avoid specifying a braking time that is long enough to cause motor overheating. If you use DC braking, we recommend using a motor with a built-in thermistor, and wiring it to the inverter's thermistor input (see [“Thermistor Thermal Protection” on page 4-22](#)). Also refer to the motor manufacturer's specifications for duty-cycle recommendations during DC braking.

"A" Function			Run Mode Edit	Defaults			
Func. Code	Name / SRW Display	Description		-FE (CE)	-FU (UL)	-FR (Jpn)	Units
A_51	DC braking enable	Two options; select codes: 00... Disable 01... Enable	✘	00	00	00	—
	DCB SW	OFF					
A_52	DC braking frequency setting	The frequency at which DC braking occurs, range is 0.5 to 10 Hz	✘	0.5	0.5	0.5	Hz
	DCB F	00.5Hz					
A_53	DC braking wait time	The delay from the end of Run command to start of DC braking (motor free runs until DC braking begins)	✘	0.0	0.0	0.0	sec.
	DCB WAIT	0.0s					
A_54	DC braking during deceleration	Applied level of DC braking force, settable from 0 to 100%	✘	0	0	0	%
	DCB V	000					
A_55	DC braking time for deceleration	Sets the duration for DC braking, range is 0.1 to 60.0 seconds	✘	0.0	0.0	0.0	sec.
	DCB T	00.0s					

Frequency-related Functions

Frequency Limits – Upper and lower limits can be imposed on the inverter output frequency. These limits will apply regardless of the source of the speed reference. You can configure the lower frequency limit to be greater than zero as shown in the graph. The upper limit must not exceed the rating of the motor or capability of the machinery.

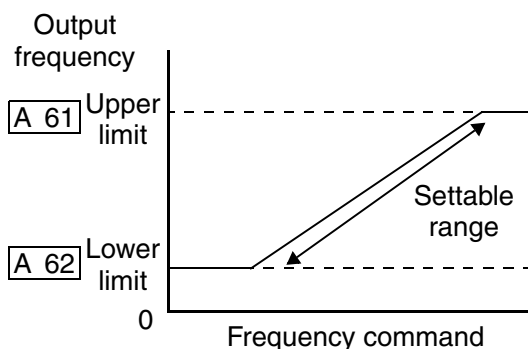

“A” Function			Run Mode Edit	Defaults			
Func. Code	Name / SRW Display	Description		-FE (CE)	-FU (UL)	-FR (Jpn)	Units
A_61	Frequency upper limit setting	Sets a limit on output frequency less than the maximum frequency (A_04) Range is 0.5 to 360.0 Hz 0.0.. setting is disabled >0.1 setting is enabled	✘	0.0	0.0	0.0	Hz
	LIMIT H 000.0Hz						
A_62	Frequency lower limit setting	Sets a limit on output frequency greater than zero Range is 0.5 to 360.0 Hz 0.0.. setting is disabled >0.1 setting is enabled	✘	0.0	0.0	0.0	Hz
	LIMIT L 000.0Hz						

Jump Frequencies – Some motors or machines exhibit resonances at particular speed(s), which can be destructive for prolonged running at those speeds. The inverter has up to three *jump frequencies* as shown in the graph. The hysteresis around the jump frequencies causes the inverter output to skip around the sensitive frequency values.

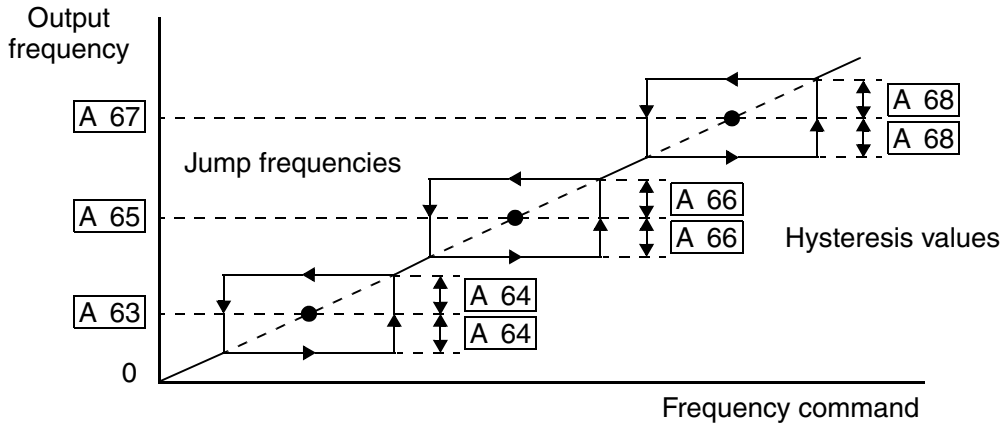

"A" Function			Run Mode Edit	Defaults			
Func. Code	Name / SRW Display	Description		-FE (CE)	-FU (UL)	-FR (Jpn)	Units
A_63, A_65, A_67	Jump (center) frequency setting JUMP F1 000.0Hz JUMP F2 000.0Hz JUMP F3 000.0Hz	Up to 3 output frequencies can be defined for the output to jump past to avoid motor resonances (center frequency) Range is 0.0 to 360.0 Hz	✘	0.0 0.0 0.0	0.0 0.0 0.0	0.0 0.0 0.0	Hz
A_64, A_66, A_68	Jump (hysteresis) frequency width setting JUMP W1 00.50Hz JUMP W2 00.50Hz JUMP W3 00.50Hz	Defines the distance from the center frequency at which the jump around occurs Range is 0.0 to 10.0 Hz	✘	0.5 0.5 0.5	0.5 0.5 0.5	0.5 0.5 0.5	Hz

PID Control

When enabled, the built-in PID loop calculates an ideal inverter output value to cause a loop feedback process variable (PV) to move closer in value to the setpoint (SP). The current frequency command serves as the SP. The PID loop algorithm will read the analog input for the process variable (you specify the current or voltage input) and calculate the output.

- A scale factor in A_75 lets you multiply the PV by a factor, converting it into engineering units for the process.
- Proportional, integral, and derivative gains are all adjustable.
- See [“PID Loop Operation” on page 4-39](#) for more information.

“A” Function			Run Mode Edit	Defaults			
Func. Code	Name / SRW Display	Description		-FE (CE)	-FU (UL)	-FR (Jpn)	Units
A_71	PID Enable	Enables PID function, two option codes: 00... PID Disable 01... PID Enable	✘	00	00	00	—
	PID SW OFF						
A_72	PID proportional gain	Proportional gain has a range of 0.2 to 5.0	✘	1.0	1.0	1.0	—
	PID P 1.0						
A_73	PID integral time constant	Integral time constant has a range of 0.0 to 150 seconds	✘	1.0	1.0	1.0	sec.
	PID I 001.0s						
A_74	PID derivative time constant	Derivative time constant has a range of 0.0 to 100 seconds	✘	0.0	0.0	0.0	sec.
	PID D 00.0						
A_75	PV scale conversion	Process Variable (PV) scale factor (multiplier), range of 0.01 to 99.99	✘	1.00	1.00	1.00	—
	PID CONV 01.00						
A_76	PV source setting	Selects source of Process Variable (PV), option codes: 00... [OI] terminal (current in) 01... [O] terminal (voltage in)	✘	00	00	00	—
	PID INPT CUR						



NOTE: The setting A_73 for the integrator is the integrator’s time constant T_i , not the gain. The integrator gain $K_i = 1/T_i$. When you set A_73 = 0, the integrator is disabled.

Automatic Voltage Regulation (AVR) Function

The automatic voltage regulation (AVR) feature keeps the inverter output waveform at a relatively constant amplitude during power input fluctuations. This can be useful if the installation is subject to input voltage fluctuations. However, the inverter cannot boost its motor output to a voltage higher than the power input voltage. If you enable this feature, be sure to select the proper voltage class setting for your motor.

“A” Function			Run Mode Edit	Defaults			
Func. Code	Name / SRW Display	Description		-FE (CE)	-FU (UL)	-FR (Jpn)	Units
A_81	AVR function select	Automatic (output) voltage regulation, selects from three type of AVR functions, three option codes: 00... AVR enabled 01... AVR disabled 02... AVR enabled except during deceleration	✘	02	00	02	—
	AVR MODE						
A_82	AVR voltage select	200V class inverter settings: 200/220/230/240 400V class inverter settings: 380/400/415/440/460	✘	230/ 400	230/ 460	200/ 400	V
	AVR AC						

Second Acceleration and Deceleration Functions

The SJ100 inverter features two-stage acceleration and deceleration ramps. This gives flexibility in the profile shape. You can specify the frequency transition point, the point at which the standard acceleration (F_02) or deceleration (F_03) changes to the second acceleration (A_92) or deceleration (A_93). These profile options are also available for the second motor settings. Select a transition frequency method via A_94 as depicted below. Be careful not to confuse the *second acceleration/deceleration settings* with settings for the *second motor*!

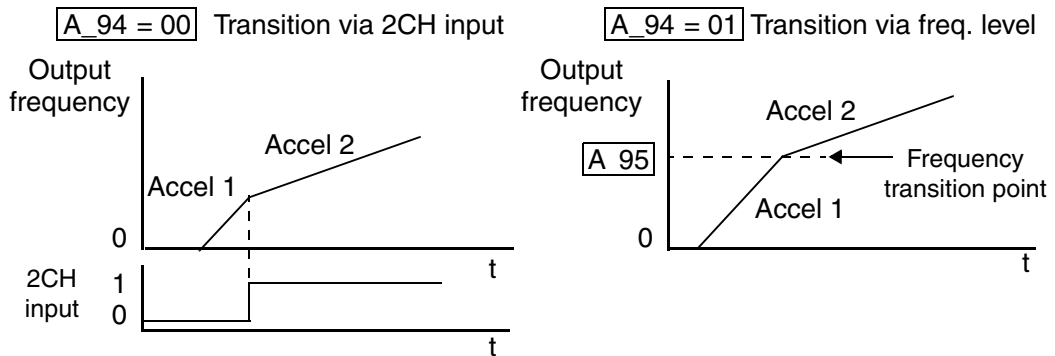

“A” Function			Run Mode Edit	Defaults			
Func. Code	Name / SRW Display	Description		-FE (CE)	-FU (UL)	-FR (Jpn)	Units
A_92	Acceleration (2) time setting	Duration of 2nd segment of acceleration, range is: 0.1 to 3000 sec.	✓	15.0	15.0	15.0	sec.
	ACC 2						
A292	Acceleration (2) time setting, (2nd motor)	Duration of 2nd segment of acceleration, 2nd motor, range is: 0.1 to 3000 sec.	✓	15.0	15.0	15.0	sec.
	2ACC2						
A_93	Deceleration (2) time setting	Duration of 2nd segment of deceleration, range is: 0.1 to 3000 sec.	✓	15.0	15.0	15.0	sec.
	DEC 2						
A293	Deceleration (2) time setting, (2nd motor)	Duration of 2nd segment of deceleration, 2nd motor, range is: 0.1 to 3000 sec.	✓	15.0	15.0	15.0	sec.
	2DEC2						
A_94	Select method to switch to Acc2/Dec2 profile	Two options for switching from 1st to 2nd accel/decel: 00... 2CH input from terminal 01... transition frequency	✗	00	00	00	—
	ACC CHG						
A294	Select method to switch to Acc2/Dec2 profile, 2nd motor	Two options for switching from 1st to 2nd accel/decel: 00... 2CH input from terminal 01... transition frequency (2nd motor)	✗	00	00	00	—
	2ACCCHG						

“A” Function			Run Mode Edit	Defaults			
Func. Code	Name / SRW Display	Description		-FE (CE)	-FU (UL)	-FR (Jpn)	Units
A_95	Acc1 to Acc2 frequency transition point	Output frequency at which Accel1 switches to Accel2, range is 0.0 to 360.0 Hz	✘	0.0	0.0	0.0	Hz
	ACC CHFr 000.0Hz						
A295	Acc1 to Acc2 frequency transition point, 2nd motor	Output frequency at which Accel1 switches to Accel2, range is 0.0 to 360.0 Hz (2nd motor)	✘	0.0	0.0	0.0	Hz
	2ACCCHF 000.0Hz						
A_96	Dec1 to Dec2 frequency transition point	Output frequency at which Decel1 switches to Decel2, range is 0.0 to 360.0 Hz	✘	0.0	0.0	0.0	Hz
	DEC CHFr 000.0Hz						
A296	Dec1 to Dec2 frequency transition point, 2nd motor	Output frequency at which Decel1 switches to Decel2, range is 0.0 to 360.0 Hz (2nd motor)	✘	0.0	0.0	0.0	Hz
	2DECCHF 000.0Hz						



NOTE: For A_95 and A_96 (and for 2nd motor settings), if you set a very rapid Acc1 or Dec1 time (less than 1.0 second), the inverter may not be able to change rates to Acc2 or Dec2 before reaching the target frequency. In that case, the inverter decreases the rate of Acc1 or Dec1 in order to achieve the second ramp to the target frequency.

Accel/Decel

Standard acceleration and deceleration is linear. The inverter CPU can also calculate an S-curve acceleration or deceleration curve as shown. This profile is useful for favoring the load characteristics in particular applications.

Curve settings for acceleration and deceleration are independently selected. To enable the S-curve, use function A_97 (acceleration) and A_98 (deceleration).

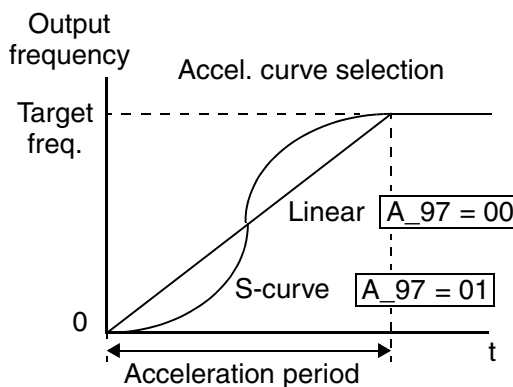

“A” Function			Run Mode Edit	Defaults			
Func. Code	Name / SRW Display	Description		-FE (CE)	-FU (UL)	-FR (Jpn)	Units
A_97	Acceleration curve selection	Set the characteristic curve of Acc1 and Acc2, two options: 00... linear 01... S-curve	✘	00	00	00	—
	ACCEL LINE						
A_98	Deceleration curve selection	Set the characteristic curve of Acc1 and Acc2, two options: 00... linear 01... S-curve	✘	00	00	00	—
	DEC LINE						

“B” Group: Fine Tuning Functions

The “B” Group of functions and parameters adjust some of the more subtle but useful aspects of motor control and system configuration.

Automatic Restart Mode

The restart mode determines how the inverter will resume operation after a fault causes a trip event. The four options provide advantages for various situations. Frequency matching allows the inverter to read the motor speed by virtue of its residual magnetic flux and restart the output at the corresponding frequency. The inverter can attempt a restart a certain number of times depending on the particular trip event:

- Over-current trip, restart up to 3 times
- Over-voltage trip, restart up to 3 times
- Under-voltage trip, restart up to 16 times

When the inverter reaches the maximum number of restarts (3 or 16), you must power-cycle the inverter to reset its operation.

Other parameters specify the allowable under-voltage level and the delay time before restarting. The proper settings depend on the typical fault conditions for your application, the necessity of restarting the process in unattended situations, and whether restarting is always safe.

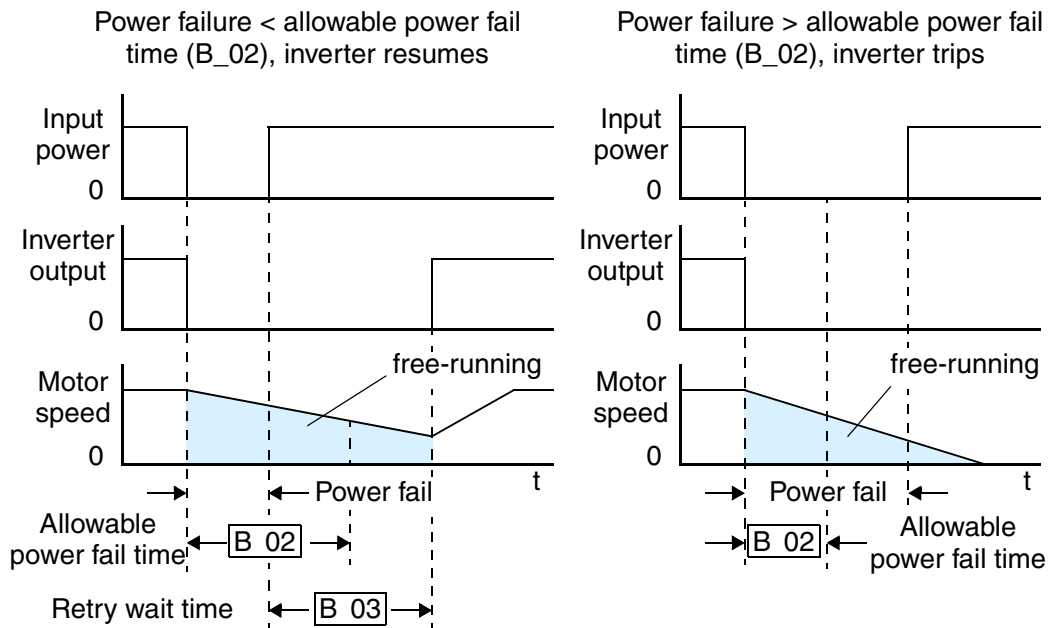

“B” Function			Run Mode Edit	Defaults			
Func. Code	Name / SRW Display	Description		-FE (CE)	-FU (UL)	-FR (Jpn)	Units
B_01	Selection of automatic restart mode	Select inverter restart method, four option codes: 00... Alarm output after trip, no automatic restart 01... Restart at 0Hz 02... Resume operation after frequency matching 03... Resume previous freq. after freq. matching, then decelerate to stop and display trip info.	✗	00	00	00	—
	IPS POWR ALM						
B_02	Allowable under-voltage power failure time	The amount of time a power input under-voltage can occur without tripping the power failure alarm. Range is 0.3 to 25 sec. If under-voltage exists longer than this time, the inverter trips, even if the restart mode is selected.	✗	1.0	1.0	1.0	sec.
	IPS UVTIME 01.0s						
B_03	Retry wait time before motor restart	Time delay after under-voltage condition goes away, before the inverter runs motor again. Range is 0.3 to 100 seconds.	✗	1.0	1.0	1.0	sec.
	IPS WAIT 001.0s						

Electronic Thermal Overload Alarm Setting

The thermal overload detection protects the inverter and motor from overheating due to an excessive load. It uses a current/inverse time curve to determine the trip point.

First, use B_13 to select the torque characteristic that matches your load. This allows the inverter to utilize the best thermal overload characteristic for your application.

The torque developed in a motor is directly proportional to the current in the windings, which is also proportional to the heat generated (and temperature, over time). Therefore, you must set the thermal overload threshold in terms of current (amperes) for parameter B_12. The range is 50% to 120% of the rated current for each inverter model. If the current exceeds the level you specify, the inverter will trip and log an event (error E05) in the history table. The inverter turns the motor output OFF when tripped. Separate settings are available for the second motor (if applicable) as shown in the following table.

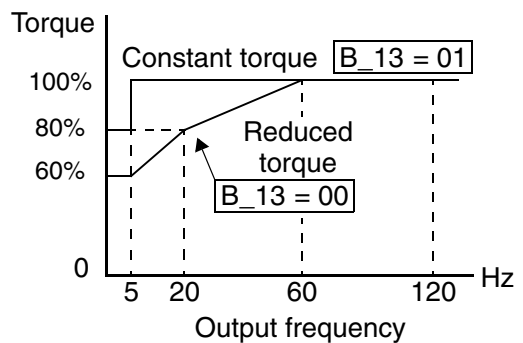

"B" Function			Run Mode Edit	Defaults			Units
Func. Code	Name / SRW Display	Description		-FE (CE)	-FU (UL)	-FR (Jpn)	
B_12	Level of electronic thermal setting E-THM LVL 03.00A	Set a level between 50% and 120% for the rated inverter current.	✗	Rated current for each inverter model *See note			A
B212	Level of electronic thermal setting, 2nd motor 2E-THMLVL 03.00A	Set a level between 50% and 120% for the rated inverter current.	✗	Rated current for each inverter model *See note			A
B_13	Electronic thermal characteristic E-THM CHAR CRT	Select from two curves, option codes: 00... Reduced torque 01... Constant torque	✗	01	01	00	—
B213	Electronic thermal characteristic, 2nd motor 2E-THMCHAR CRT	Select from two curves, option codes: 00... Reduced torque 01... Constant torque	✗	01	01	00	—



WARNING: When parameter B_12, level of electronic thermal setting, is set to device FLA rating (Full Load Ampere nameplate rating), the device provides solid state motor overload protection at 115% of device FLA or equivalent. Parameter B_12, level of electronic thermal setting, is a variable parameter.



NOTE: For inverter models 005NFE, 011NFE, and 030HFE, the thermal value is less than the rated amperes (is the same as models 004NFE, 007NFE, and 040HFE respectively). Therefore, be sure to set the electronic thermal overload according to the actual motor driven by the particular inverter.

Overload Restriction

If the inverter’s output current exceeds a preset current level you specify during acceleration or constant speed, the overload restriction feature automatically reduces the output frequency to restrict the overload. This feature does not generate an alarm or trip event. You can instruct the inverter to apply overload restriction only during constant speed, thus allowing higher currents for acceleration. Or, you may use the same threshold for both acceleration and constant speed. In the case of controlled deceleration, the inverter monitors both output current and DC bus voltage. The inverter will increase output frequency to try to avoid a trip due to over-current or over-voltage (due to regeneration).

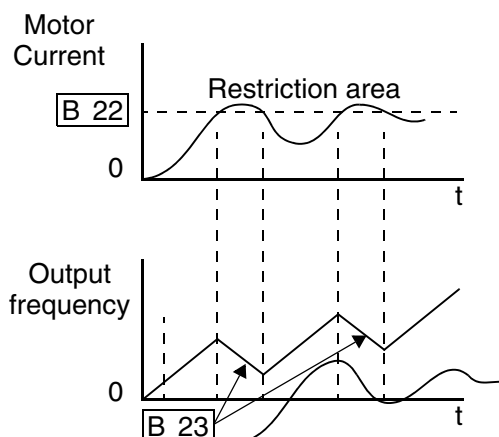

When the inverter detects an overload, it must decelerate the motor to reduce the current until it is less than the threshold. You can choose the rate of deceleration that the inverter uses to lower the output current.

“B” Function			Run Mode Edit	Defaults			Units
Func. Code	Name / SRW Display	Description		-FE (CE)	-FU (UL)	-FR (Jpn)	
B_21	Overload restriction operation mode	Select the operating mode during overload conditions, three options, option codes: 00... Disabled 01... Enabled for acceleration and constant speed 02... Enabled for constant speed only	✗	01	01	01	—
	OLOAD MODE 0N						
B_22	Overload restriction setting	Sets the level for overload restriction, between 50% and 150% of the rated current of the inverter, setting resolution is 1% of rated current	✗	Rated current x 1.25			A
	OLOAD LVL 03.75A						
B_23	Deceleration rate at overload restriction	Sets the deceleration rate when inverter detects overload, range is 0.1 to 30.0, resolution is 0.1.	✗	1.0	1.0	1.0	—
	OLOAD CONST 01.0						

Software Lock Mode

The software lock function keeps personnel from accidentally changing parameters in the inverter memory. Use B_31 to select from various protection levels.

The table below lists all combinations of B_31 option codes and the ON/OFF state of the [SFT] input. Each Check ✓ or Ex ✗ indicates whether the corresponding parameter(s) can be edited. The Standard Parameters column below shows access is permitted for some lock modes. These refer to the parameter tables throughout this chapter, each of which includes a column titled *Run Mode Edit* as shown to the right. The marks (Check ✓ or Ex ✗) under the “Run Mode Edit” column title indicate whether access applies to each parameter as defined in the table below. In some lock modes, you can edit only F_01 and the Multi-speed parameter group that includes A_20, A220, A_21–A_35, and A_38 (Jog). However, it does not include A_19, Multi-speed operation selection. The editing access to B_31 itself is unique, and is specified in the right-most two columns below.

	Run Mode Edit	
	✗	
	✓	

B_31 Lock Mode	[SFT] Intelligent Input	Standard Parameters		F_01 and Multi-Speed	B_31	
		Stop	Run	Stop & Run	Stop	Run
00	OFF	✓	Run mode edit access	✓	✓	✗
	ON	✗	✗	✗	✓	✗
01	OFF	✓	Run mode edit access	✓	✓	✗
	ON	✗	✗	✓	✓	✗
02	(ignored)	✗	✗	✗	✓	✗
03	(ignored)	✗	✗	✓	✓	✗



NOTE: Since the software lock function B_31 is always accessible, this feature is not the same as password protection used in other industrial control devices.

“B” Function			Run Mode Edit	Defaults			
Func. Code	Name / SRW Display	Description		-FE (CE)	-FU (UL)	-FR (Jpn)	Units
B_31	Software lock mode selection	Prevents parameter changes, in four options, option codes: 00... all parameters except B_31 are locked when [SFT] terminal is ON 01... all parameters except B_31 and output frequency F_01 when [SFT] terminal is ON 02... all parameters except B_31 are locked 03... all parameters except B_31 and output frequency F_01 setting are locked	✘	01	01	01	—
	S-LOCK MD1						



NOTE: To disable parameter editing when using B_31 lock modes 00 and 01, assign the [SFT] function to one of the intelligent input terminals. See [“Software Lock” on page 4-19](#).

Miscellaneous Settings

The miscellaneous settings include scaling factors, initialization modes, and others. This section covers some of the most important settings you may need to configure.

B_83: Carrier frequency adjustment – The internal *switching frequency* of the inverter circuitry (also called the *chopper frequency*). It is called the carrier frequency because the lower AC output frequency of the inverter “rides” the carrier. The faint, high-pitched sound you hear when the inverter is in Run Mode is characteristic of switching power supplies in general. The carrier frequency is adjustable from 500 Hz to 16 kHz. The audible sound decreases at the higher frequencies, but RFI noise and leakage current may be increased. Refer to the specification derating curves in Chapter 1 to determine the maximum allowable carrier frequency setting for your particular inverter and environmental conditions.



NOTE: When DC braking is performed, the inverter automatically holds the carrier frequency at 1 kHz.



NOTE: When the inverter is in sensorless vector mode, use B_83 to set the carrier frequency greater than 2.1 kHz for proper operation.



NOTE: The carrier frequency setting must stay within specified limits for inverter-motor applications that must comply with particular regulatory agencies. For example, a European CE-approved application requires the inverter carrier to be less than 5 kHz.

B_84, B_85: Initialization codes – These functions allow you to restore the factory default settings. Please refer to [“Restoring Factory Default Settings” on page 6–8](#).

B_86: Frequency display scaling – You can convert the output frequency monitor on D_01 to a scaled number (engineering units) monitored at function D_07. For example, the motor may run a conveyor that is monitored in feet per minute. Use this formula:

$$\text{Scaled output frequency (D_07)} = \text{Output frequency (D_01)} \times \text{Factor (B_86)}$$

“B” Function			Run Mode Edit	Defaults			
Func. Code	Name / SRW Display	Description		-FE (CE)	-FU (UL)	-FR (Jpn)	Units
B_81	[FM] terminal analog meter adjustment	Adjust 8-bit gain to analog meter connected to terminal [FM], range is 0 to 255	✓	80	80	80	—
	ADJ						
B_82	Start frequency adjust- ment	Sets the starting frequency for the inverter output, range is 0.5 to 9.9 Hz	✗	0.5	0.5	0.5	Hz
	Fmin						
B_83	Carrier frequency setting	Sets the PWM carrier (internal switching frequency), range is 0.5 to 16.0 kHz	✗	5.0	5.0	12.0	kHz
	CARRIER						
B_84	Initialization mode (parameters or trip history)	Select the type of initialization to occur, two option codes: 00... Trip history clear 01... Parameter initialization	✗	00			—
	INIT MODE						
B_85	Country code for initial- ization	Select default parameter values for country on initialization, four options, option codes: 00... Japan version 01... Europe version 02... US version 03... reserved (do not set)	✗	01	02	00	—
	INIT SEL						
B_86	Frequency scaling conversion factor	Specify a constant to scale the displayed frequency for D_07 monitor, range is 0.1 to 99.9	✗	1.0	1.0	1.0	—
	/Hz01.0						
B_87	STOP key enable	Select whether the STOP key on the keypad is enabled, two option codes: 00... enabled 01... disabled	✗	00	00	00	—
	STOP-SW						

B_91/B_88: Stop Mode / Restart Mode Configuration – You can configure how the inverter performs a standard stop (each time Run FWD and REV signals turn OFF). Setting B_91 determines whether the inverter will control the deceleration, or whether it will perform a free-run stop (coast to a stop). When using the free-run stop selection, it is imperative to also configure how you want the inverter to resume control of motor speed. Setting B_88 determines whether the inverter will ensure the motor always resumes at 0 Hz, or whether the motor resumes from its current coasting speed (also called *frequency matching*). The Run command may turn OFF briefly, allowing the motor to coast to a slower speed from which normal operation can resume.

In most applications a controlled deceleration is desirable, corresponding to B_91=00. However, applications such as HVAC fan control will often use a free-run stop (B_91=01). This practice decreases dynamic stress on system components, prolonging system life. In this case, you will typically set B_88=01 in order to resume from the current speed after a free-run stop (see diagram below, right). Note that using the default setting, B_88=00, can cause trip events when the inverter attempts to force the load quickly to zero speed.



NOTE: Other events can cause (or be configured to cause) a free-run stop, such as power loss (see [“Automatic Restart Mode” on page 3-24](#)), or an intelligent input terminal [FRS] signal. If all free-run stop behavior is important to your application (such as HVAC), be sure to configure each event accordingly.

An additional parameter further configures all instances of a free-run stop. Parameter B_03, Retry Wait Time Before Motor Restart, sets the minimum time the inverter will free-run. For example, if B_03 = 4 seconds (and B_91=01) and the cause of the free-run-stop lasts 10 seconds, the inverter will free-run (coast) for a total of 14 seconds before driving the motor again.

B_91 = 01 Stop Mode = free-run stop
B_88 = 00 Resume from 0Hz

B_91 = 01 Stop Mode = free-run stop
B_88 = 01 Resume from current speed

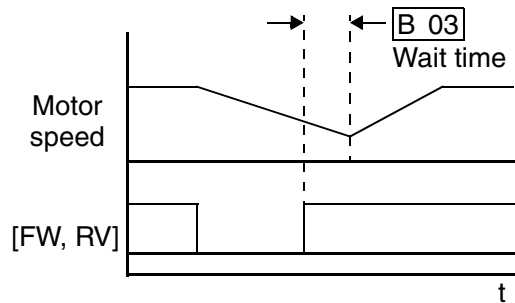
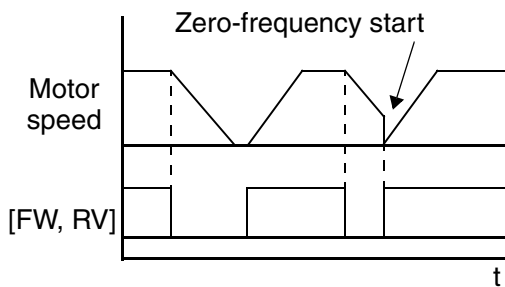

“B” Function			Run Mode Edit	Defaults			
Func. Code	Name / SRW Display	Description		-FE (CE)	-FU (UL)	-FR (Jpn)	Units
B_88	Restart mode after FRS	Selects how the inverter resumes operation when the free-run stop (FRS) is cancelled, two options: 00... Restart from 0Hz 01... Restart from frequency detected from real speed of motor (frequency matching)	✘	00	00	00	—
	RUN FRS ZST						
B_89	Data select for digital operator OPE-J	Select the monitoring data to send to the optional remote hand-held digital operator, seven option codes: 01... Output frequency (D_01) 02... Output current (D_02) 03... Motor direction (D_03) 04... PID PV feedback (D_04) 05... Input states for input terminals (D_05) 06... Output states for output terminals (D_06) 07... Scaled output frequency (D_07)	✔	01	01	01	—
	PANEL d01						
B_90	Dynamic braking usage ratio	Selects the rate of use (in %) of the regenerative braking resistor per 100 sec. intervals, range is 0.0 to 100.0% 0% . Dynamic braking disabled >0% Enabled, per value	✘	0.0	0.0	0.0	%
	BRD-%ED 000.0%						
B_91	Stop mode selection	Selects how the inverter stops the motor, two option codes: 00... DEC (decelerate and stop) 01... FRS (free run to stop)	✘	00	00	00	—
	RUN STP DEC						
B_92	Cooling fan control	Selects when the fan is ON per inverter operation, two options: 00... Fan is always ON 01... Fan is ON during run, OFF during stop	✘	00	00	00	—
	INIT FAN-CTL OFF						

B_90: Dynamic braking usage ratio – This parameter limits the amount of time the inverter can use the dynamic braking accessory device without entering the Trip Mode. Please refer to [“Dynamic Braking” on page 5-5](#) for more information on dynamic braking accessories.

“C” Group: Intelligent Terminal Functions

The six input terminals [1], [2], [3], [4], [5], and [6] can be configured for any of 19 different functions. The next two tables show how to configure the six terminals. The inputs are logical, in that they are either OFF or ON. We define these states as OFF=0, and ON=1.

The inverter comes with default options for the six terminals. These default settings are initially unique, each one having its own setting. Note that European and US versions have different default settings. You can use any option on any terminal, and even use the same option twice to create a logical OR (though usually not required).



NOTE: Terminal [5] has the ability to be a logical input, and to be an analog input for a thermistor device when the PTC function (option code 19) is assigned to that terminal.

Input Terminal Configuration

Functions and Options –The *function codes* in the following table let you assign one of nineteen options to any of the six logic inputs for the SJ100 inverters. The functions C_01 through C_06 configure the terminals [1] through [6] respectively. The “value” of these particular parameters is not a scalar value, but it is a discrete number that selects one option from many available *options*.

For example, if you set function C_01=00, you have assigned option 00 (Forward Run) to terminal [1]. The option codes and the specifics of how each one works are in Chapter 4.

“C” Function			Run Mode Edit	Defaults			
Func. Code	Name / SRW Display	Description		-FE (CE)	-FU (UL)	-FR (Jpn)	Units
C_01	Terminal [1] function	Select function for terminal [1] 18 options (see next section)	✘	00 [FW]	00 [FW]	00 [FW]	—
	IN-TM 1 FW						
C_02	Terminal [2] function	Select function for terminal [2] 18 options (see next section)	✘	01 [RV]	01 [RV]	01 [RV]	—
	IN-TM 2 RV						
C_03	Terminal [3] function	Select function for terminal [3] 18 options (see next section)	✘	02 [CF1]	16 [AT]	02 [CF1]	—
	IN-TM 3 AT						
C_04	Terminal [4] function	Select function for terminal [4] 18 options (see next section)	✘	03 [CF2]	13 [USP]	03 [CF2]	—
	IN-TM 4 USP						
C_05	Terminal [5] function	Select function for terminal [5] 19 options (see next section)	✘	18 [RS]	09 [2CH]	09 [2CH]	—
	IN-TM 5 2CH						
C_06	Terminal [6] function	Select function for terminal [6] 18 options (see next section)	✘	09 [2CH]	18 [RS]	18 [RS]	—
	IN-TM 6 RS						

The input logic convention is programmable for each of the six inputs. Most inputs default to normally open (active high), but you can select normally closed (active low) in order to invert the sense of the logic.

“C” Function			Run Mode Edit	Defaults			
Func. Code	Name / SRW Display	Description		-FE (CE)	-FU (UL)	-FR (Jpn)	Units
C_11	Terminal [1] active state	Select logic convention, two option codes: 00... normally open [NO] 01... normally closed [NC]	✘	00	00	00	—
	IN-TM O/C-1 NO						
C_12	Terminal [2] active state	Select logic convention, two option codes: 00... normally open [NO] 01... normally closed [NC]	✘	00	00	00	—
	IN-TM O/C-2 NO						
C_13	Terminal [3] active state	Select logic convention, two option codes: 00... normally open [NO] 01... normally closed [NC]	✘	00	00	00	—
	IN-TM O/C-3 NO						
C_14	Terminal [4] active state	Select logic convention, two option codes: 00... normally open [NO] 01... normally closed [NC]	✘	00	01	00	—
	IN-TM O/C-4 NC						
C_15	Terminal [5] active state	Select logic convention, two option codes: 00... normally open [NO] 01... normally closed [NC]	✘	00	00	00	—
	IN-TM O/C-5 NO						
C_16	Terminal [6] active state	Select logic convention, two option codes: 00... normally open [NO] 01... normally closed [NC]	✘	00	00	00	—
	IN-TM O/C-6 NO						



NOTE: An input terminal configured for option code 18 ([RS] Reset command) cannot be configured for normally closed operation.

Intelligent Input Terminal Overview

Each of the six intelligent terminals may be assigned any of the options in the following table. When you program one of the option codes for terminal assignments C_01 to C_06, the respective terminal assumes the function role of that option code. The terminal functions have a symbol or abbreviation that we use to label a terminal using that function. For example the “Forward Run” command is [FW]. The physical label on the terminal block connector is simply **1, 2, 3, 4, 5, or 6**. However, schematic examples in this manual also use the terminal symbol (such as [FW]) to show the assigned option. The option codes for C_11 to C_16 determines the active state of the logical input (active high or active low).

Input Function Summary Table – This table shows all nineteen intelligent input functions at a glance. Detailed descriptions of these functions, related parameters and settings, and example wiring diagrams are in [“Using Intelligent Input Terminals” on page 4-8](#).

Input Function Summary Table				
Option Code	Terminal Symbol	Function Name	Description	
00	FW	Forward Run/Stop	ON	Inverter is in Run Mode, motor runs forward
			OFF	Inverter is in Stop Mode, motor stops
01	RV	Reverse Run/Stop	ON	Inverter is in Run Mode, motor runs reverse
			OFF	Inverter is in Stop Mode, motor stops
02	CF1	Multi-speed Select, Bit 0 (LSB)	ON	Binary encoded speed select, Bit 0, logical 1
			OFF	Binary encoded speed select, Bit 0, logical 0
03	CF2	Multi-speed Select, Bit 1	ON	Binary encoded speed select, Bit 1, logical 1
			OFF	Binary encoded speed select, Bit 1, logical 0
04	CF3	Multi-speed Select, Bit 2	ON	Binary encoded speed select, Bit 2, logical 1
			OFF	Binary encoded speed select, Bit 2, logical 0
05	CF4	Multi-speed Select, Bit 3 (MSB)	ON	Binary encoded speed select, Bit 3, logical 1
			OFF	Binary encoded speed select, Bit 3, logical 0
06	JG	Jogging	ON	Inverter is in Run Mode, output to motor runs at jog parameter frequency
			OFF	Inverter is in Stop Mode
07	DB	External DC Braking	ON	DC braking will be applied during deceleration
			OFF	DC braking will not be applied
08	SET	Set (select) 2nd Motor Data	ON	The inverter uses 2nd motor parameters for generating frequency output to motor
			OFF	The inverter uses 1st (main) motor parameters for generating frequency output to motor
09	2CH	2-stage Acceleration and Deceleration	ON	Frequency output uses 2nd-stage acceleration and deceleration values
			OFF	Frequency output uses standard acceleration and deceleration values
11	FRS	Free-run Stop	ON	Causes output to turn OFF, allowing motor to free run (coast) to stop
			OFF	Output operates normally, so controlled deceleration stops motor
12	EXT	External Trip	ON	When assigned input transitions OFF to ON, inverter latches trip event and displays E12
			OFF	No trip event for ON to OFF, any recorded trip events remain in history until Reset

Input Function Summary Table				
Option Code	Terminal Symbol	Function Name	Description	
13	USP	Unattended Start Protection	ON	On powerup, the inverter will not resume a Run command (mostly used in the US)
			OFF	On powerup, the inverter will resume a Run command that was active before power loss
15	SFT	Software Lock	ON	The keypad and remote programming devices are prevented from changing parameters
			OFF	The parameters may be edited and stored
16	AT	Analog Input Voltage/current Select	ON	Terminal [OI] is enabled for current input (uses terminal [L] for power supply return)
			OFF	Terminal [O] is enabled for voltage input (uses terminal [L] for power supply return)
18	RS	Reset Inverter	ON	The trip condition is reset, the motor output is turned OFF, and powerup reset is asserted
			OFF	Normal power-ON operation
19	PTC	PTC Thermistor Thermal Protection	ANLG	When a thermistor is connected to terminals [5] and [L], the inverter checks for over-temperature and will cause trip event and turn OFF output to motor
			OPEN	A disconnect of the thermistor causes a trip event, and the inverter turns OFF the motor
27	UP	Remote Control UP Function (motorized speed pot.)	ON	Accelerates (increases output frequency) motor from current frequency
			OFF	Output to motor operates normally
28	DWN	Remote Control DOWN Function (motorized speed pot.)	ON	Decelerates (decreases output frequency) motor from current frequency
			OFF	Output to motor operates normally

Output Terminal Configuration

The inverter provides configuration for logic (discrete) and analog outputs, shown in the table below.

“C” Function			Run Mode Edit	Defaults			
Func. Code	Name / SRW Display	Description		-FE (CE)	-FU (UL)	-FR (Jpn)	Units
C_21	Terminal [11] function	Select function for terminal [11], 6 options (see next section)	✗	01 [FA1]	01 [FA1]	01 [FA1]	—
	OUT-TM 1 FA1						
C_22	Terminal [12] function	Select function for terminal [12], 6 options (see next section)	✗	00 [RUN]	00 [RUN]	00 [RUN]	—
	OUT-TM 2 RUN						
C_23	[FM] signal selection	Select function for terminal [FM], 3 options (see next section)	✗	00 [A-F]	00 [A-F]	00 [A-F]	—
	MONITOR A-F						
C_24	Alarm relay terminal function	Select function for alarm terminals, 6 options (see next section)	✗	05 [AL]	05 [AL]	05 [AL]	—
	OUT-TM RY AL						

The output logic convention is programmable for terminals [11], [12], and the alarm relay terminals. The open-collector output terminals [11] and [12] default to normally open (active low), but you can select normally closed (active high) for these terminals in order to invert the sense of the logic. You can invert the logical sense of the alarm relay output as well.

“C” Function			Run Mode Edit	Defaults			
Func. Code	Name / SRW Display	Description		-FE (CE)	-FU (UL)	-FR (Jpn)	Units
C_31	Terminal [11] active state (-FU)	Select logic convention, two option codes: 00... normally open [NO] 01... normally closed [NC]	✗	—	00	—	—
	OUT-TM O/C-1 NO						
	Reserved (-FE / -FR) (not displayed)	(reserved) DO NOT EDIT	✗	00	—	00	—
C_32	Terminal [12] active state (-FU)	Select logic convention, two option codes: 00... normally open [NO] 01... normally closed [NC]	✗	—	00	—	—
	OUT-TM O/C-2 NO						
	Terminal [11] active state (-FE / -FR)	(reserved) DO NOT EDIT	✗	00	—	00	—
	OUT-TM O/C-1 NO						

“C” Function			Run Mode Edit	Defaults			
Func. Code	Name / SRW Display	Description		-FE (CE)	-FU (UL)	-FR (Jpn)	Units
C_33	Alarm relay active state OUT-TM O/C-RY NO	Select logic convention, two option codes: 00... normally open [NO] 01... normally closed [NC]	✘	01	01	01	—

Output Function Summary Table – This table shows all six functions for the logical outputs (terminals [11], [12]) at a glance. Detailed descriptions of these functions, related parameters and settings, and example wiring diagrams are in [“Using Intelligent Output Terminals”](#) on page 4-24.

Output Function Summary Table				
Option Code	Terminal Symbol	Function Name	Description	
00	RUN	Run Signal	ON	when inverter is in Run Mode
			OFF	when inverter is in Stop Mode
01	FA1	Frequency Arrival Type 1 – Constant Speed	ON	when output to motor is at the set frequency
			OFF	when output to motor is OFF, or in any acceleration or deceleration ramp
02	FA2	Frequency Arrival Type 2 – Over-frequency	ON	when output to motor is at or above the set frequency, even if in accel. or decel. ramps
			OFF	when output to motor is OFF, or at a level below the set frequency
03	OL	Overload Advance Notice Signal	ON	when output current is more than the set threshold for the overload signal
			OFF	when output current is less than the set threshold for the overload signal
04	OD	Output Deviation for PID Control	ON	when PID error is more than the set threshold for the deviation signal
			OFF	when PID error is less than the set threshold for the deviation signal
05	AL	Alarm Signal	ON	when an alarm signal has occurred and has not been cleared
			OFF	when no alarm has occurred since the last clearing of alarm(s)

Analog Function Summary Table – This table shows all three functions for the analog output [FM] (frequency meter) terminal. Detailed descriptions, related parameters and settings, and example wiring diagrams are in [“Analog and Digital Monitor Output” on page 4-33](#).

Analog Function Summary Table		
Option Code	Function Name	Description
00	Analog Frequency Monitor	PWM (pulse-width-modulated) voltage output that has a duty cycle proportional to the inverter output frequency
01	Analog Current Output Monitor	PWM (pulse-width-modulated) voltage output that has a duty cycle proportional to the inverter output current to the motor. It reaches 100% duty cycle when the output reaches 200% of the rated inverter current.
02	Digital Frequency Output Monitor	FM (frequency-modulated) voltage output with a constant 50% duty cycle. Its frequency = inverter output frequency.

Output Function Adjustment Parameters

The following parameters work in conjunction with the intelligent output function, when configured. The overload level parameter (C_41) sets the motor current level at which the overload signal [OD] turns ON. The range of settings is from 0% to 200% of the rated current for the inverter. This function is for generating an early warning logic output, without causing either a trip event or a restriction of the motor current (those effects are available on other functions).

The frequency arrival signal, [FA1] or [FA2], is intended to indicate when the inverter output has reached (arrived at) the target frequency. You can adjust the timing of the leading and trailing edges of the signal via two parameters specific to acceleration and deceleration ramps, C_42 and C_43.

The Error for the PID loop is the magnitude (absolute value) of the difference between the Setpoint (desired value) and Process Variable (actual value). The PID output deviation signal [OD] (output terminal function option code 04) indicates when the error magnitude has exceeded a magnitude you define.

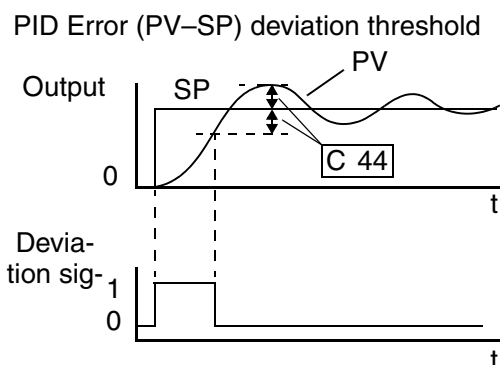
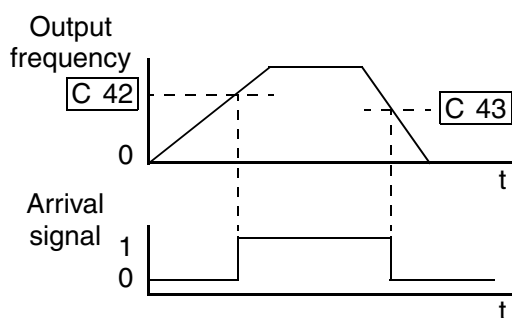
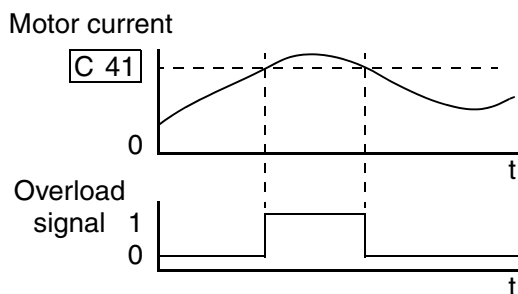

"C" Function			Run Mode Edit	Defaults			
Func. Code	Name / SRW Display	Description		-FE (CE)	-FU (UL)	-FR (Jpn)	Units
C_41	Overload level setting OV Load 03.00A	Sets the overload signal level between 0% and 200% (from 0 to two times the rated current of the inverter)	X	Rated current for each inverter model			
C_42	Frequency arrival setting for acceleration ARV ACC 000.0Hz	Sets the frequency arrival setting threshold for the output frequency during acceleration	X	0.0	0.0	0.0	Hz

“C” Function			Run Mode Edit	Defaults			
Func. Code	Name / SRW Display	Description		-FE (CE)	-FU (UL)	-FR (Jpn)	Units
C_43	Arrival frequency setting for deceleration	Sets the frequency arrival setting threshold for the output frequency during deceleration	✘	0.0	0.0	0.0	Hz
	ARV DEC 000.0Hz						
C_44	PID deviation level setting	Sets the allowable PID loop error magnitude (absolute value), SP - PV, range is 0.0 to 100%, resolution is 0.1%	✘	3.0	3.0	3.0	%
	OV PID 003.0%						
C_81	O input span calibration	Scale factor between the external frequency command on terminals L – O (voltage input) and the frequency output	✘	Factory-calibrated			—
	ADJ-O 082						
C_82	OI input span calibration	Scale factor between the external frequency command on terminals L – OI (current input) and the frequency output	✘	Factory-calibrated			—
	ADJ-OI 066						
C_91	Debug mode enable	(Reserved) DO NOT EDIT	✘	00	00	00	—
	INIT DEBG OFF						
C_92	Core monitor address	(Reserved) DO NOT EDIT	✘	0000	0000	0000	—
	(not displayed)						
C_93	Core monitor date	(Reserved) DO NOT EDIT	✘	—	—	—	—
	(not displayed)						
C_94	Core set address	(Reserved) DO NOT EDIT	✘	D_01	D_01	D_01	—
	(not displayed)						
C_95	Core set date	(Reserved) DO NOT EDIT	✘	00	00	00	—
	(not displayed)						



NOTE: Settings C_81 and C_82 are factory-calibrated for each inverter. Do not change these settings unless absolutely necessary. Note that if you restore factory defaults for all parameters, these settings will not change.

“H” Group: Motor Constants Functions

Introduction

The “H” Group parameters configure the inverter for the motor characteristics. You must manually set H_03 and H_04 values to match the motor. The remaining parameters are related to sensorless vector control (SLV), and are in use only when function A_44 is set for SLV as shown in the diagram. The procedure in [“Auto-tuning for Sensorless Vector Control” on page 4-35](#) automatically sets all the parameters related to SLV. If you configure the inverter to use SLV, we highly recommend letting the auto-tuning procedure derive the values for you. If you want to reset the parameters to the factory default settings, use the procedure in [“Restoring Factory Default Settings” on page 6-8](#).

Inverter Torque Control Algorithms

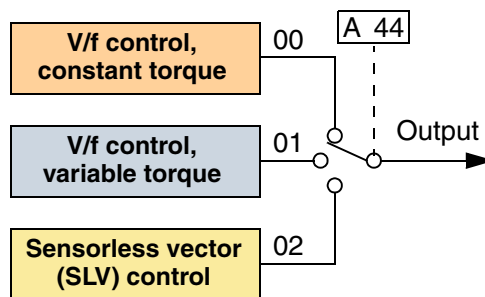

NOTE: The auto-tuning procedure and related warning messages are in [“Auto-tuning for Sensorless Vector Control” on page 4-35](#). Please read these before trying to auto-tune the motor parameters.

“H” Function			Run Mode Edit	Defaults			Units
Func. Code	Name / SRW Display	Description		-FE (CE)	-FU (UL)	-FR (Jpn)	
H_01	Auto-tuning Setting	Three states for auto-tuning function, option codes: 00... Auto-tuning OFF 01... Auto-tune (rotate motor) 02... Auto-tune (measure motor resistance and inductance, without rotating)	✗	00	00	00	—
	AUX AUTO						
H_02	Motor data selection	Two selections, option codes: 00... Use standard motor data 01... Use auto-tuning data	✗	00	00	00	—
	AUX DATA						
H202	Motor data selection, 2nd motor	Two selections, option codes: 00... Use standard motor data 01... Use auto-tuning data	✗	00	00	00	—
	2AUXDATA						
H_03	Motor capacity	Nine selections: 0.2 / 0.4 / 0.75 / 1.5 / 2.2 / 3.7 5.5 / 7.5 / 11	✗	Specified by the capacity of each inverter model			kW
	AUX K						
H203	Motor capacity, 2nd setting	Nine selections: 0.2 / 0.4 / 0.75 / 1.5 / 2.2 / 3.7 5.5 / 7.5 / 11	✗	Specified by the capacity of each inverter model			—
	2AUXK						
H_04	Motor poles setting	Four selections: 2 / 4 / 6 / 8	✗	4	4	4	poles
	AUX P						

"H" Function			Run Mode Edit	Defaults			
Func. Code	Name / SRW Display	Description		-FE (CE)	-FU (UL)	-FR (Jpn)	Units
H204	Motor poles setting, 2nd motor	Four selections: 2 / 4 / 6 / 8	✗	4	4	4	poles
	2AUXP						
H_05	Motor speed constant	Motor proportional gain constant (factory set), range is 0 to 99	✗	20	20	20	—
	AUX KP						
H205	Motor speed constant, 2nd motor	Motor proportional gain constant (factory set) range is 0 to 99	✗	20	20	20	—
	2AUXKP						
H_06	Motor stabilization constant	Motor constant (factory set), range is 0 to 255	✗	100	100	100	—
	AUX KCD						
H206	Motor stabilization constant, 2nd motor	Motor constant (factory set), range is 0 to 255	✗	100	100	100	—
	2AUXKCD						
H_20	Motor constant R1	Range is 0.000 to 65.53, 0.000 to 9.999 10.00 to 65.53	✗	Factory set according to inverter model			Ohms
	AUX R1						
H220	Motor constant R1, 2nd motor	Range is 0.000 to 65.53, 0.000 to 9.999 10.00 to 65.53	✗	Factory set according to inverter model			Ohms
	2AUXR1						
H_21	Motor constant R2	Range is 0.000 to 65.53, 0.000 to 9.999 10.00 to 65.53	✗	Factory set according to inverter model			Ohms
	AUX R2						
H221	Motor constant R2, 2nd motor	Range is 0.000 to 65.53, 0.000 to 9.999 10.00 to 65.53	✗	Factory set according to inverter model			Ohms
	2AUXR2						
H_22	Motor constant L	Range is 0.00 - 655.3 mH, 0.00 to 99.99 100.0 - 655.3	✗	Factory set according to inverter model			mH
	AUX L						
H222	Motor constant L, 2nd motor	Range is 0.00 - 655.3 mH, 0.00 to 99.99 100.0 - 655.3	✗	Factory set according to inverter model			mH
	2AUXL						
H_23	Motor constant I _o	Range is 0.00 to 655.3 Amps, 0.00 to 99.99 100.0 - 655.3	✗	Factory set according to inverter model			Arms
	AUX I0						
H223	Motor constant I _o , 2nd motor	Range is 0.00 to 655.3 Amps, 0.00 to 99.99 100.0 - 655.3	✗	Factory set according to inverter model			Arms
	2AUXI0						

“H” Function			Run Mode Edit	Defaults			
Func. Code	Name / SRW Display	Description		-FE (CE)	-FU (UL)	-FR (Jpn)	Units
H_24	Motor Constant J	Ratio (unit-less), range is 1.0 to 1000	✘	Factory set according to inverter model			—
	AUX J 0020.0						
H224	Motor constant J, 2nd motor	Ratio (unit-less), range is 1.0 to 1000	✘	Factory set according to inverter model			—
	2AUXJ 0020.0						
H_30	Auto-tuned motor constant R1	Auto-tuning data (do not edit)	✘	Factory set according to inverter model			—
	(not displayed)						
H230	Auto-tuned motor constant R1, 2nd motor	Auto-tuning data (do not edit)	✘	Factory set according to inverter model			—
	(not displayed)						
H_31	Auto-tuned motor constant R2	Auto-tuning data (do not edit)	✘	Factory set according to inverter model			—
	(not displayed)						
H231	Motor constant R2, 2nd motor	Auto-tuning data (do not edit)	✘	Factory set according to inverter model			—
	(not displayed)						
H_32	Auto-tuned motor constant L	Auto-tuning data (do not edit)	✘	Factory set according to inverter model			—
	(not displayed)						
H232	Auto-tuned motor constant L, 2nd motor	Auto-tuning data (do not edit)	✘	Factory set according to inverter model			—
	(not displayed)						
H_33	Auto-tuned motor constant I _o	Auto-tuning data (do not edit)	✘	Factory set according to inverter model			—
	(not displayed)						
H233	Auto-tuned motor constant I _o , 2nd motor	Auto-tuning data (do not edit)	✘	Factory set according to inverter model			—
	(not displayed)						
H_34	Auto-tuned motor constant J	Auto-tuning data (do not edit)	✘	Factory set according to inverter model			—
	(not displayed)						
H234	Auto-tuned motor constant J, 2nd motor	Auto-tuning data (do not edit)	✘	Factory set according to inverter model			—
	(not displayed)						

Operations and Monitoring



In This Chapter....	page
— Introduction	2
— Connecting to PLCs and Other Devices	4
— Using Intelligent Input Terminals	8
— Using Intelligent Output Terminals	24
— Analog Input Operation	32
— Analog and Digital Monitor Output	33
— Auto-tuning for Sensorless Vector Control	35
— PID Loop Operation	39
— Configuring the Inverter for Multiple Motors ..	40

Introduction

The previous material in Chapter 3 gave a reference listing of all the programmable functions of the inverter. We suggest that you first scan through the listing of inverter functions to gain a general familiarity. This chapter will build on that knowledge in the following ways:

1. **Related functions** – Some parameters interact with or depend on the settings in other functions. This chapter lists “required settings” for a programmable function to serve as a cross-reference and an aid in showing how functions interact.
2. **Intelligent terminals** – Some functions rely on an input signal on a control logic connector terminal, or generate output signals in other cases.
3. **Electrical interfaces** – This chapter shows how to make connections between the inverter and other electrical devices.
4. **Auto-tuning** – The SJ100 inverter has the ability to run a calibration procedure that takes measurements of the motor’s electrical characteristics. This chapter shows how to run the auto-tuning procedure to help the inverter run the motor more smoothly and efficiently.
5. **PID Loop Operation** – The SJ100 has a built-in PID loop that calculates the optimal inverter output frequency to control an external process. This chapter shows the parameters and input/output terminals associated with PID loop operation.
6. **Multiple motors** – A single SJ100 inverter may be used with two or more motors in some types of applications. This chapter shows the electrical connections and inverter parameters involved in multiple-motor applications.

The topics in this chapter can help you decide the features that are important to your application, and how to use them. The basic installation covered in Chapter 2 concluded with the powerup test and running the motor. Now, this chapter starts from that point and shows how to make the inverter part of a larger control or automation system.

Caution Messages for Operating Procedures

Before continuing, please read the following Caution messages.



CAUTION: The heat sink fins will have a high temperature. Be careful not to touch them. Otherwise, there is the danger of getting burned.



CAUTION: The operation of the inverter can be easily changed from low speed to high speed. Be sure check the capability and limitations of the motor and machine before operating the inverter. Otherwise, it may cause injury to personnel.



CAUTION: If you operate a motor at a frequency higher than the inverter standard default setting (50Hz/60Hz), be sure to check the motor and machine specifications with the respective manufacturer. Only operate the motor at elevated frequencies after getting their approval. Otherwise, there is the danger of equipment damage.

Warning Messages for Operating Procedures

Before continuing, please read the following Warning messages.



WARNING: Be sure to turn ON the input power supply only after closing the front case. While the inverter is energized, be sure not to open the front case. Otherwise, there is the danger of electric shock.



WARNING: Be sure not to operate electrical equipment with wet hands. Otherwise, there is the danger of electric shock.



WARNING: While the inverter is energized, be sure not to touch the inverter terminals even when the motor is stopped. Otherwise, there is the danger of electric shock.



WARNING: If the Retry Mode is selected, the motor may suddenly restart after a trip stop. Be sure to stop the inverter before approaching the machine (be sure to design the machine so that safety for personnel is secure even if it restarts.) Otherwise, it may cause injury to personnel.



WARNING: If the power supply is cut OFF for a short period of time, the inverter may restart operation after the power supply recovers if the Run command is active. If a restart may pose danger to personnel, so be sure to use a lock-out circuit so that it will not restart after power recovery. Otherwise, it may cause injury to personnel.



WARNING: The Stop Key is effective only when the Stop function is enabled. Be sure to enable the Stop Key separately from the emergency stop. Otherwise, it may cause injury to personnel.



WARNING: During a trip event, if the alarm reset is applied and the Run command is present, the inverter will automatically restart. Be sure to apply the alarm reset only after verifying the Run command is OFF. Otherwise, it may cause injury to personnel.



WARNING: Be sure not to touch the inside of the energized inverter or to put any conductive object into it. Otherwise, there is a danger of electric shock and/or fire.



WARNING: If power is turned ON when the Run command is already active, the motor will automatically start and injury may result. Before turning ON the power, confirm that the RUN command is not present.



WARNING: When the Stop key function is disabled, pressing the Stop key does not stop the inverter, nor will it reset a trip alarm.



WARNING: Be sure to provide a separate, hard-wired emergency stop switch when the application warrants it.

Connecting to PLCs and Other Devices

Hitachi inverters (drives) are useful in many types of applications. During installation, the inverter keypad (or other programming device) will facilitate the initial configuration. After installation, the inverter will generally receive its control commands through the control logic connector or serial interface from another controlling device. In a simple application such as single-conveyor speed control, a Run/Stop switch and potentiometer will give the operator all the required control. In a sophisticated application, you may have a *programmable logic controller* (PLC) as the system controller, with several connections to the inverter.

It is not possible to cover all the possible types of application in this manual. It will be necessary for you to know the electrical characteristics of the devices you want to connect to the inverter. Then, this section and the following sections on I/O terminal functions can help you quickly and safely connect those devices to the inverter.



CAUTION: It is possible to damage the inverter or other devices if your application exceeds the maximum current or voltage characteristics of a connection point.

The connections between the inverter and other devices rely on the electrical input/output characteristics at both ends of each connection, shown in the diagram to the right. The inverter's inputs require a sourcing output from an external device (such as a PLC). This chapter shows the inverter's internal electrical component(s) at each I/O terminal. In some cases, you will need to insert a power source in the interface wiring.

In order to avoid equipment damage and get your application running smoothly, we recommend drawing a schematic of each connection between the inverter and the other device. Include the internal components of each device in the schematic, so that it makes a complete circuit loop.

After making the schematic, then:

1. Verify that the current and voltage for each connection is within the operating limits of each device.
2. Make sure that the logic sense (active high or active low) of any ON/OFF connection is correct.
3. Check the zero and span (curve end points) for analog connections, and be sure the scale factor from input to output is correct.
4. Understand what will happen at the system level if any particular device suddenly loses power, or powers up after other devices.

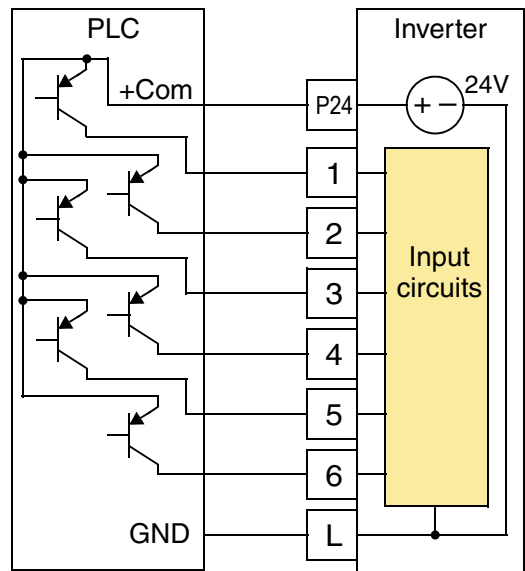
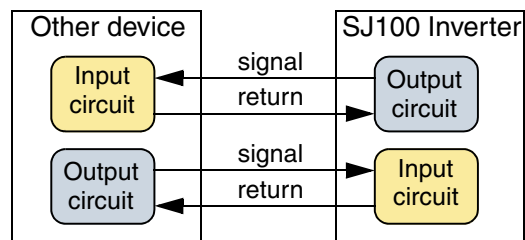

Example Wiring Diagram

The schematic diagram below provides a general example of logic connector wiring, in addition to basic power and motor wiring covered in Chapter 2. The goal of this chapter is to help you determine the proper connections for the various terminals shown below for your specific application needs.

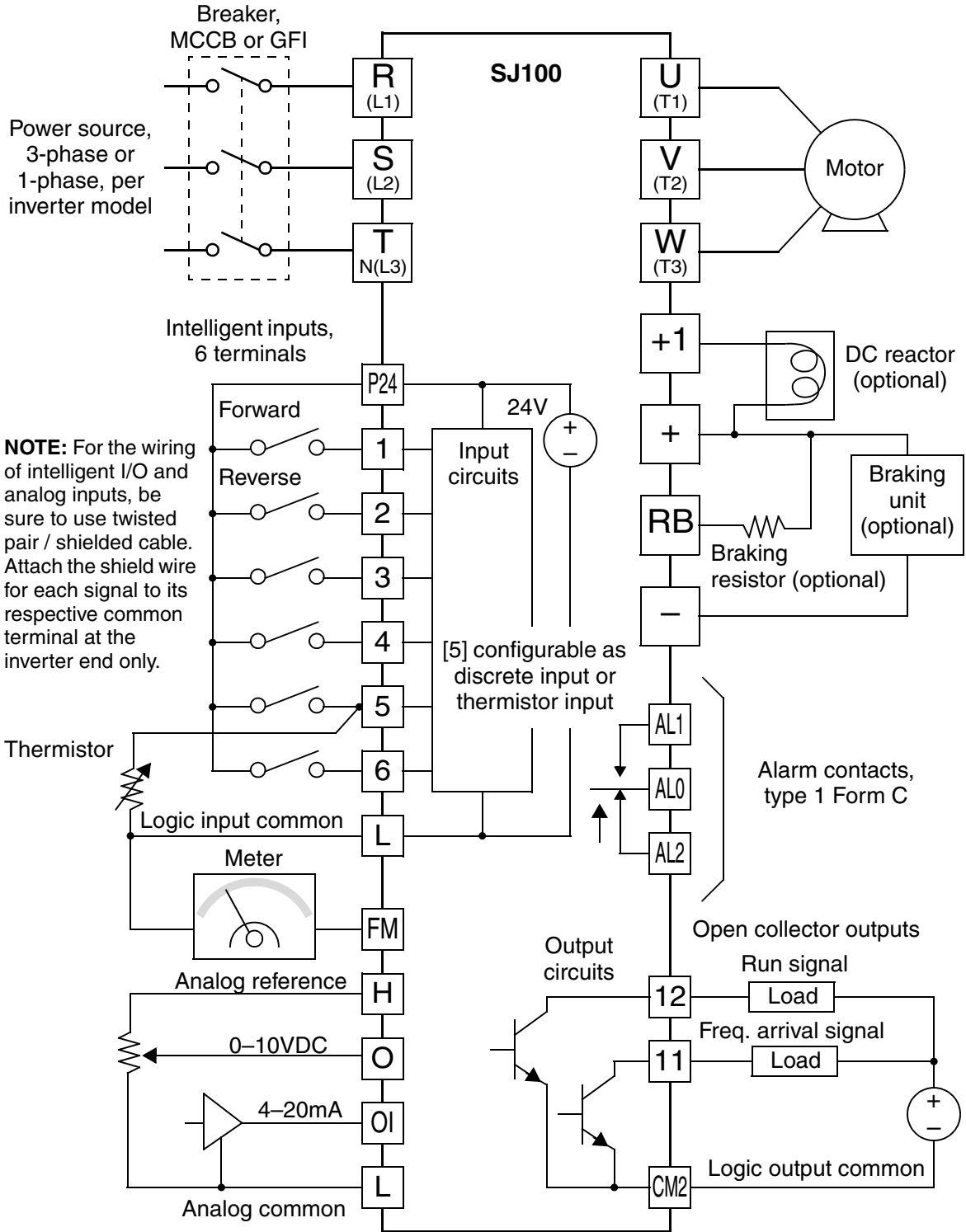

Specifications of Control and Logic Connections

The control logic connectors are located just behind the front panel half-door. The relay contacts are accessible behind the main door. Connector labeling is shown below.

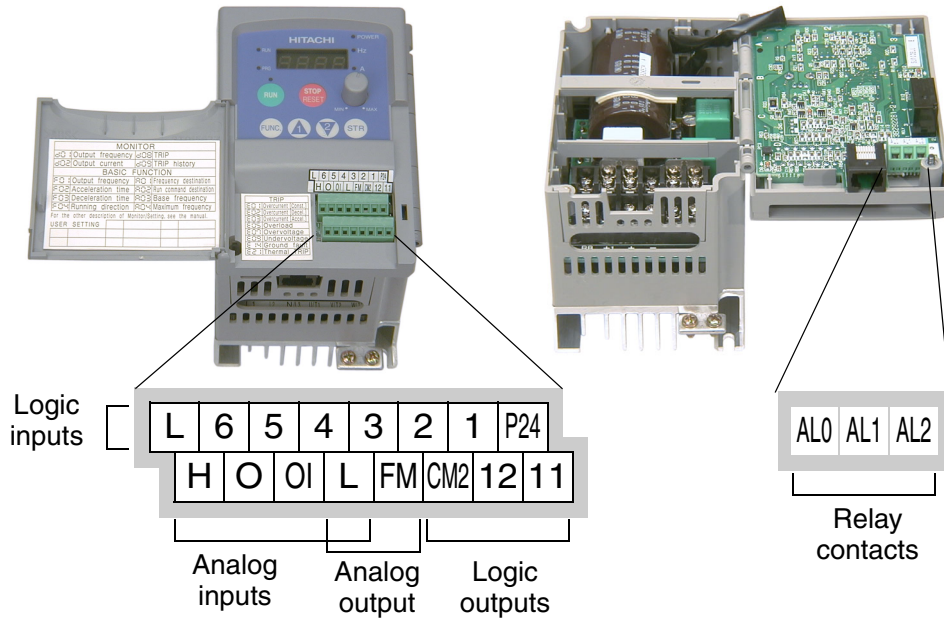

Specifications for the logic connection terminals are in the following table:

Terminal Name	Description	Ratings
[P24]	+24V for logic inputs	24VDC, 30 mA max (do not short to terminal L)
[1], [2], [3], [4], [5], [6]	Discrete logic inputs	27VDC max. (use P24 or an external supply referenced to terminal L)
[L] (top row) *1	GND for logic inputs	sum of input 1-6 currents (return)
[11], [12]	Discrete logic outputs	50mA maximum ON state current, 27 VDC maximum OFF state voltage
[CM2]	GND for logic outputs	100 mA: sum of 11 and 12 currents (return)
[FM]	PWM (analog/digital) output	0 to 10VDC, 1 mA, PWM and 50% duty digital
[L] (bottom row) *1	GND for analog inputs	sum of OI, O, and H currents (return)
[OI]	Analog input, current	4 to 19.6 mA range, 20 mA nominal
[O]	Analog input, voltage	0 to 9.6 VDC range, 10VDC nominal, input impedance 10 kΩ
[H]	+10V analog reference	10VDC nominal, 10 mA max
[AL0]	Relay common contact	250 VAC, 2.5A (R load) max., 250 VAC, 0.2A (I load, P.F.=0.4) max.
[AL1]	Relay contact, normally closed during RUN	100 VAC, 10mA min. 30 VDC, 3.0A (R load) max.
[AL2]	Relay contact, normally open during RUN	30 VDC, 0.7A (I load, P.F.=0.4) max. 5 VDC, 100mA min.

Note 1: The two terminals [L] are electrically connected together inside the inverter.

Terminal Listing

Use the following tables to locate pages for intelligent input and output material in this chapter.

Intelligent Inputs			
Symbol	Code	Name	Page
FW	00	Forward Run/Stop	4-9
RV	01	Reverse Run/Stop	4-9
CF1	02	Multi-speed Select, Bit 0 (LSB)	4-10
CF2	03	Multi-speed Select, Bit 1	4-10
CF3	04	Multi-speed Select, Bit 2	4-10
CF4	05	Multi-speed Select, Bit 3	4-10
JG	06	Jogging	4-12
DB	07	External DC Braking	4-13
SET	08	Set Second Motor	4-14
2CH	09	2-stage Acceleration and Deceleration	4-15
FRS	11	Free-run Stop	4-16
EXT	12	External Trip	4-17
USP	13	Unattended Start Protection	4-18
SFT	15	Software Lock	4-19
AT	16	Analog Input Voltage/current Select	4-20
RS	18	Reset Inverter	4-21
TH	19	Thermistor Thermal Protection	4-22
UP	27	Remote Control UP Function	4-23
DWN	28	Remote Control DOWN Function	4-23

Intelligent Outputs			
Symbol	Code	Name	Page
RUN	00	Run Signal	4-25
FA1	01	Frequency Arrival Type 1 – Constant Speed	4-26
FA2	02	Frequency Arrival Type 2 – Over-frequency	4-26
OL	03	Overload Advance Notice Signal	4-28
OD	04	Output Deviation for PID Control	4-29
AL	05	Alarm Signal	4-30

Using Intelligent Input Terminals

Terminals [1], [2], [3], [4], [5], and [6] are identical, programmable inputs for general use. The input circuits can use the inverter's internal (isolated) +24V field supply (P24) to power the inputs. The input circuits are internally connected to the power supply ground. As the diagram shows, you can use a switch (or jumper) to activate an input terminal that has been configured.

If you use an external supply, its GND terminal must connect to the [L] terminal on the inverter to complete the input circuit. Current can only flow *into* each input, so they are sinking inputs, whether powered internally or externally.



NOTE: We recommend using the top row [L] logic GND for logic input circuits and the [L] GND on the bottom row of terminals for analog I/O circuits.

Sinking inputs,
internal supply

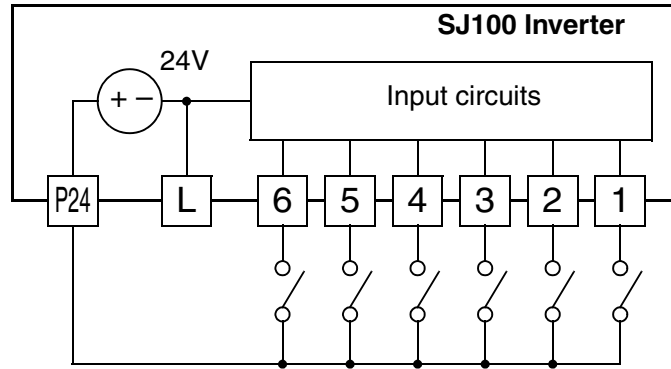

Sinking inputs,
external supply

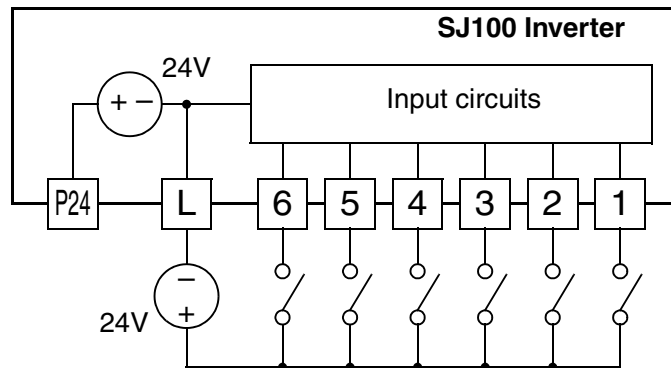

Forward Run/Stop and Reverse Run/Stop Commands:

When you input the Run command via the terminal [FW], the inverter executes the Forward Run command (high) or Stop command (low). When you input the Run command via the terminal [RV], the inverter executes the Reverse Run command (high) or Stop command (low).

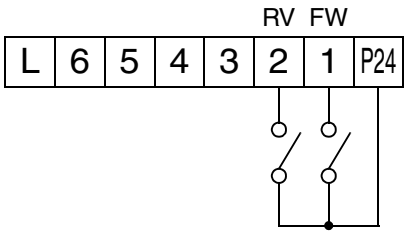
Option Code	Terminal Symbol	Function Name	State	Description
00	FW	Forward Run/Stop	ON	Inverter is in Run Mode, motor runs forward
			OFF	Inverter is in Stop Mode, motor stops
01	RV	Reverse Run/Stop	ON	Inverter is in Run Mode, motor runs reverse
			OFF	Inverter is in Stop Mode, motor stops
Valid for inputs:		C_01, C_02, C_03, C_04, C_05, C_06		Example (default input configuration shown—see page 3-34): 
Required settings:		A_02 = 01		
Notes: <ul style="list-style-type: none"> • When the Forward Run and Reverse Run commands are active at the same time, the inverter enters the Stop Mode. • When a terminal associated with either [FW] or [RV] function is configured for <i>normally closed</i>, the motor starts rotation when that terminal is disconnected or otherwise has no input voltage. 				

See I/O specs on page 4-6.



NOTE: The parameter F_04, Keypad Run Key Routing, determines whether the single Run key issues a Run FWD command or Run REV command. However, it has no effect on the [FW] and [RV] input terminal operation.



WARNING: If the power is turned ON and the Run command is already active, the motor starts rotation and is dangerous! Before turning power ON, confirm that the Run command is not active.

Multi-Speed Select

The inverter can store up to 16 different target frequencies (speeds) that the motor output uses for steady-state run condition. These speeds are accessible through programming four of the intelligent terminals as binary-encoded inputs CF1 to CF4 per the table to the right. These can be any of the six inputs, and in any order. You can use fewer inputs if you need eight or fewer speeds.



Note: When choosing a subset of speeds to use, always start at the top of the table, and with the least-significant bit: CF1, CF2, etc.

The example with eight speeds in the figure below shows how input switches configured for CF1–CF3 functions can change the motor speed in real time.

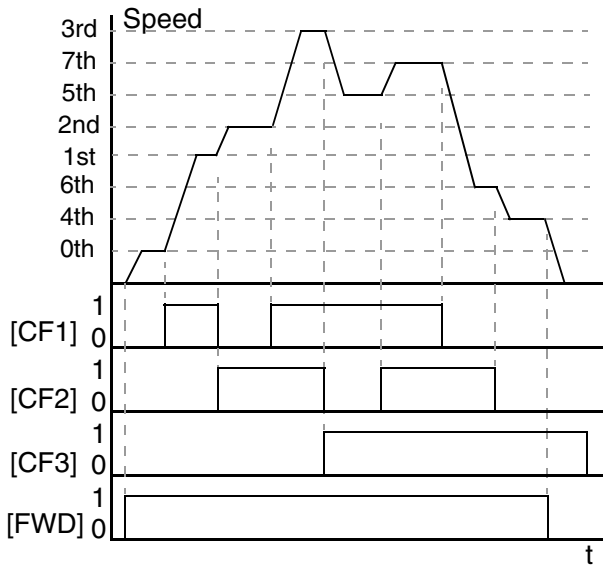

Multi-speed	Input Function			
	CF4	CF3	CF2	CF1
Speed 0	0	0	0	0
Speed 1	0	0	0	1
Speed 2	0	0	1	0
Speed 3	0	0	1	1
Speed 4	0	1	0	0
Speed 5	0	1	0	1
Speed 6	0	1	1	0
Speed 7	0	1	1	1
Speed 8	1	0	0	0
Speed 9	1	0	0	1
Speed 10	1	0	1	0
Speed 11	1	0	1	1
Speed 12	1	1	0	0
Speed 13	1	1	0	1
Speed 14	1	1	1	0
Speed 15	1	1	1	1

NOTE: Speed 0 is set by the A_20 parameter value.

Option Code	Terminal Symbol	Function Name	Input State	Description
02	CF1	Multi-speed Select, Bit 0 (LSB)	ON	Binary encoded speed select, Bit 0, logical 1
			OFF	Binary encoded speed select, Bit 0, logical 0
03	CF2	Multi-speed Select, Bit 1	ON	Binary encoded speed select, Bit 1, logical 1
			OFF	Binary encoded speed select, Bit 1, logical 0
04	CF3	Multi-speed Select, Bit 2	ON	Binary encoded speed select, Bit 2, logical 1
			OFF	Binary encoded speed select, Bit 2, logical 0

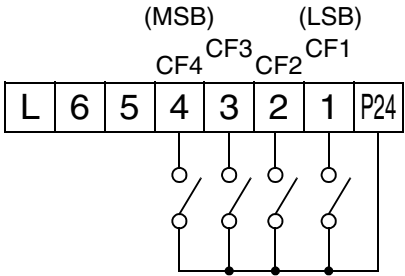
Option Code	Terminal Symbol	Function Name	Input State	Description
05	CF4	Multi-speed Select, Bit 3 (MSB)	ON	Binary encoded speed select, Bit 3, logical 1
			OFF	Binary encoded speed select, Bit 3, logical 0
Valid for inputs:		C_01, C_02, C_03, C_04, C_05, C_06	Example (some CF inputs require input configuration; some are default inputs—see page 3-34): 	
Required settings:		F_01, A_01 = 02, A_20 to A_35		
Notes:		<ul style="list-style-type: none"> When programming the multi-speed settings, be sure to press the Store key each time and then set the next multi-speed setting. Note that when the key is not pressed, no data will be set. When a multi-speed setting more than 50Hz(60Hz) is to be set, it is necessary to program the maximum frequency A_04 high enough to allow that speed. 		
				See I/O specs on page 4-6 .

While using the multi-speed capability, you can monitor the current frequency with monitor function D_01 during each segment of a multi-speed operation. There are two ways to program the speeds into the registers A_20 to A_35:

1. Standard keypad programming:

- Select each parameter A_20 to A_35.
- Press the $\text{\textcircled{FUNC}}$ key to view the parameter value.
- Use the $\text{\textcircled{\u2191}}$ and $\text{\textcircled{\u2193}}$ keys to edit the value.
- Use the $\text{\textcircled{STR}}$ key to save the data to memory.

2. Programming using the CF switches. Set the speed by following these steps:

- Turn the Run command OFF (Stop Mode).
- Turn each switch ON and set it to Multi-speed. Display the value of F_01 on the digital operator.
- Set the desired output frequency by pressing the $\text{\textcircled{\u2191}}$ and $\text{\textcircled{\u2193}}$ keys.
- Press the $\text{\textcircled{STR}}$ key once to store the set frequency. When this occurs, F_01 indicates the output frequency of Multi-speed n.
- Press the $\text{\textcircled{FUNC}}$ key once to confirm that the indication is the same as the set frequency.
- Repeat operations in 2. a) to 2. e) to set the frequency of other Multi-speeds. It can be set also by parameters A_20 to A_35 in the first procedure 1. a) to 1. d).

Jogging Command

The Jog input [JG] is used to command the motor to rotate slowly in small increments for manual operation. The speed is limited to 10 Hz. The frequency for the jogging operation is set by parameter A_38. Jogging does not use an acceleration ramp, so we recommend setting the jogging frequency A_38 to 5 Hz or less to prevent tripping.

When the terminal [JG] is turned ON and the Run command is issued, the inverter outputs the programmed jog frequency to the motor. To enable the Run key on the digital operator for jog input, set the value 01 (terminal mode) in A_02 (Run command source).

The type of deceleration used to end a motor jog operation is selectable by programming function A_39. The options are:

- 00 Free-run stop (coasting)
- 01 Deceleration (normal level) and stop
- 02 Use DC braking and stop

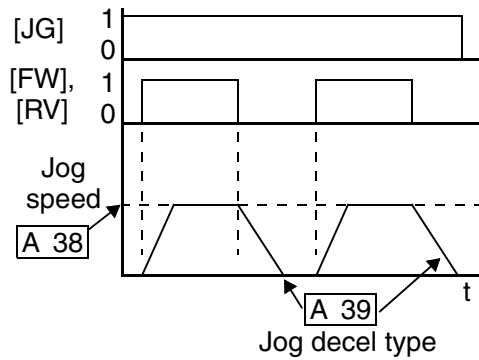

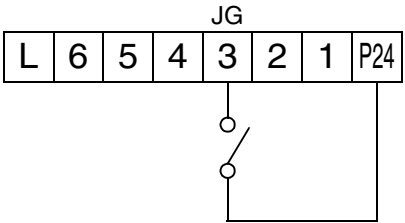
Option Code	Terminal Symbol	Function Name	Input State	Description
06	JG	Jogging	ON	Inverter is in Run Mode, output to motor runs at jog parameter frequency
			OFF	Inverter is in Stop Mode
Valid for inputs:		C_01, C_02, C_03, C_04, C_05, C_06		Example (requires input configuration—see page 3-34): 
Required settings:		A_02= 01, A_38 > B_82, A_38 > 0, A_39		
Notes:		<ul style="list-style-type: none"> • No jogging operation is performed when the set value of jogging frequency A_38 is smaller than the start frequency B_82, or the value is 0 Hz. • Be sure to stop the motor when switching the function [JG] ON or OFF. 		
				See I/O specs on page 4-6.

External Signal for DC Braking

When the terminal [DB] is turned ON, the DC braking feature is enabled. Set the following parameters when the external DC braking terminal [DB] is to be used:

- A_53 – DC braking delay time setting. The range is 0.1 to 5.0 seconds.
- A_54 – DC braking force setting. The range is 0 to 100%.

The scenarios to the right help show how DC braking works in various situations.

1. Scenario 1 – The [FW] or [RV] terminal is ON. When [DB] is ON, DC braking is applied. When [DB] is OFF again, the output frequency ramps to the prior level.
2. Scenario 2 – The Run command is applied from the operator keypad. When the [DB] terminal is ON, DC braking is applied. When the [DB] terminal is OFF again, the inverter output remains OFF.
3. Scenario 3 – The Run command is applied from the operator keypad. When the [DB] terminal is ON, DC braking is applied after the delay time set by A_53 expires. The motor is in a free-running (coasting) condition. When the [DB] terminal is OFF again, the inverter output remains OFF.

Scenario 1

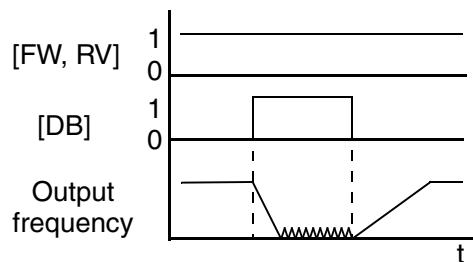

Scenario 2

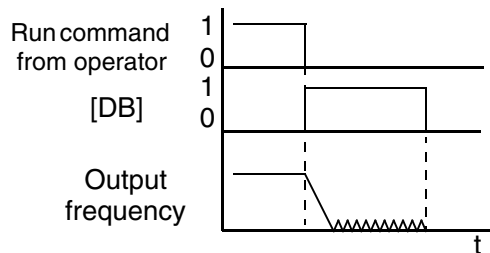

Scenario 3

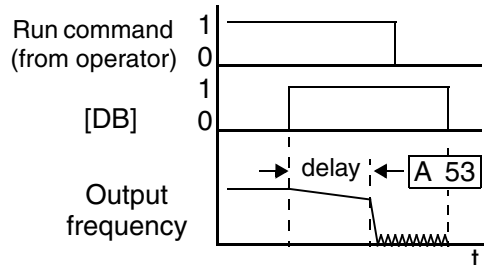

Option Code	Terminal Symbol	Function Name	Input State	Description
07	DB	External DC Braking	ON	applies DC injection braking during deceleration
			OFF	does not apply DC injection braking during deceleration
Valid for inputs:		C_01, C_02, C_03, C_04, C_05, C_06		Example (requires input configuration—see page 3-34):
Required settings:		A_53, A_54		
Notes:				
<ul style="list-style-type: none"> • Do not use the [DB] input continuously or for a long time when the DC braking force setting A_54 is high (depends on the motor application). • Do not use the [DB] feature for continuous or high duty cycle as a holding brake. The [DB] input is designed to improve stopping performance. Use a mechanical brake for holding a stop position. 				<p>See I/O specs on page 4-6.</p>

Set Second Motor

If you assign the [SET] function to an intelligent input terminal, you can select between two sets of motor parameters. The second parameters store an alternate set of motor characteristics. When the terminal [SET] is turned ON, the inverter will use the second set of parameters to generate the frequency output to the motor. When changing the state of the [SET] input terminal, the change will not take effect until the inverter is stopped.

When you turn ON the [SET] input, the inverter operates per the second set of parameters. When the terminal is turned OFF, the output function returns to the original settings (first set of motor parameters). Refer to [“Configuring the Inverter for Multiple Motors” on page 4-40](#) for details.

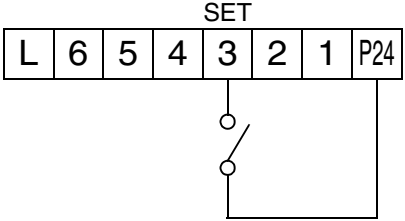
Option Code	Terminal Symbol	Function Name	Input State	Description
08	SET	Set (select) 2nd Motor Data	ON	causes the inverter to use the 2nd set of motor parameters for generating the frequency output to motor
			OFF	causes the inverter to use the 1st (main) set of motor parameters for generating the frequency output to motor
Valid for inputs:		C_01, C_02, C_03, C_04, C_05, C_06	Example (requires input configuration—see page 3-34): 	
Required settings:		(none)		
Notes:		<ul style="list-style-type: none"> If the terminal state is changed while the inverter is running, the inverter continues using the current set of parameters until the inverter is stopped. 		
				See I/O specs on page 4-6 .

Two-stage Acceleration and Deceleration

When terminal [2CH] is turned ON, the inverter changes the rate of acceleration and deceleration from the initial settings (F_02 and F_03) to use the second set of acceleration/deceleration values. When the terminal is turned OFF, the inverter is returned to the original acceleration and deceleration time (F_02 acceleration time 1, and F_03 deceleration time 1). Use A_92 (acceleration time 2) and A_93 (deceleration time 2) to set the second stage acceleration and deceleration times.

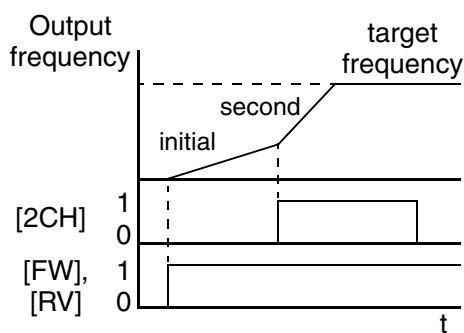

In the graph shown above, the [2CH] becomes active during the initial acceleration. This causes the inverter to switch from using acceleration 1 (F_02) to acceleration 2 (A_92).

Option Code	Terminal Symbol	Function Name	Input State	Description
09	2CH	Two-stage Acceleration and Deceleration	ON	Frequency output uses 2nd-stage acceleration and deceleration values
			OFF	Frequency output uses the initial acceleration 1 and deceleration 1 values
Valid for inputs:		C_01, C_02, C_03, C_04, C_05, C_06	Example (default input configurations shown—see page 3-34):	
Required settings:		A_92, A_93, A_94=00		
<p>Notes:</p> <ul style="list-style-type: none"> Function A_94 selects the method for second stage acceleration. It must be set = 00 to select the input terminal method in order for the [2CH] terminal assignment to operate. 				
<div style="text-align: center;"> <p>See I/O specs on page 4-6.</p> </div>				

Free-run Stop

When the terminal [FRS] is turned ON, the inverter stops the output and the motor enters the free-run state (coasting). If terminal [FRS] is turned OFF, the output resumes sending power to the motor if the Run command is still active. The free-run stop feature works with other parameters to provide flexibility in stopping and starting motor rotation.

In the figure below, parameter B_88 selects whether the inverter resumes operation from 0 Hz (left graph) or the current motor rotation speed (right graph) when the [FRS] terminal turns OFF. The application determines the best setting.

Parameter B_03 specifies a delay time before resuming operation from a free-run stop. To disable this feature, use a zero delay time.

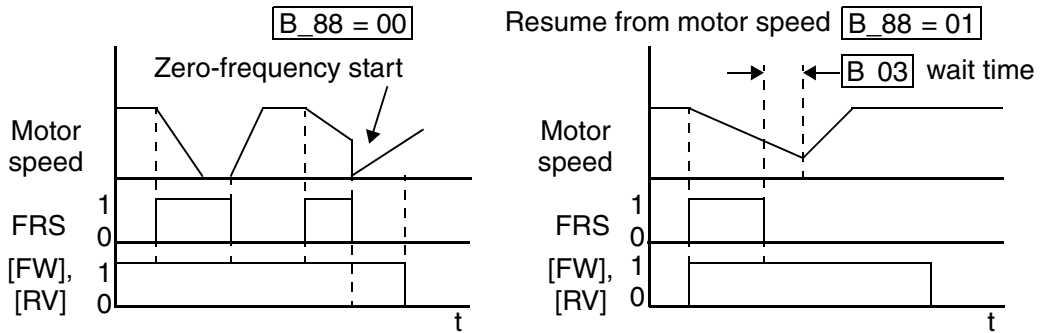

Option Code	Terminal Symbol	Function Name	Input State	Description
11	FRS	Free-run Stop	ON	Causes output to turn OFF, allowing motor to free run (coast) to stop
			OFF	Output operates normally, so controlled deceleration stops motor
Valid for inputs:		C_01, C_02, C_03, C_04, C_05, C_06	Example (requires input configuration—see page 3-34): 	
Required settings:		B_03, B_88, C_11 to C_16		
Notes:		<ul style="list-style-type: none"> When you want the [FRS] terminal to be active low (normally closed logic), change the setting (C_11 to C_16) that corresponds to the input (C_01 to C_06) that is assigned the [FRS] function. 		
				See I/O specs on page 4-6 .

External Trip

When the terminal [EXT] is turned ON, the inverter enters the trip state, indicates error code E12, and stops the output. This is a general purpose interrupt type feature, and the meaning of the error depends on what you connect to the [EXT] terminal. Even if the [EXT] input is turned OFF, the inverter remains in the trip state. You must reset the inverter or cycle power to clear the error, returning the inverter to the Stop Mode.

In the graph below, the [EXT] input turns ON during normal Run Mode operation. The inverter lets the motor free-run to a stop, and the alarm output turns ON immediately. When the operator initiates a Reset command, the alarm and error are cleared. When the Reset is turned OFF, the motor begins rotation since the Run command is already active.

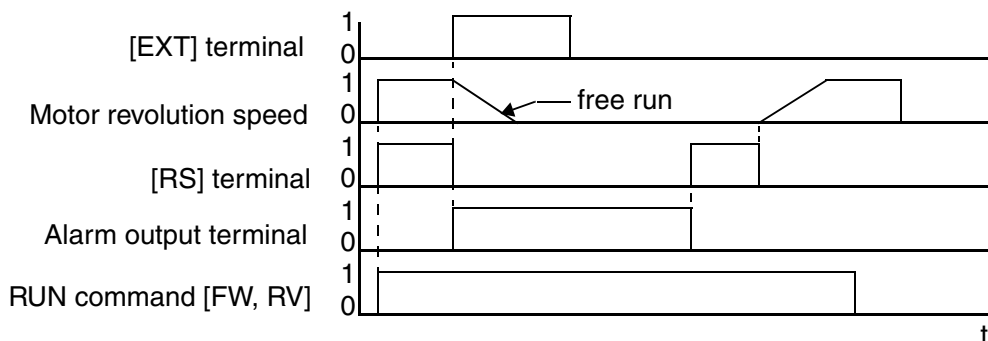

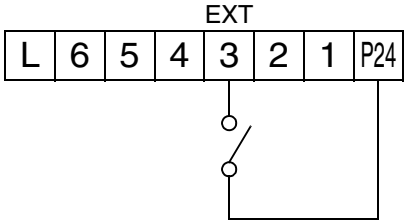
Option Code	Terminal Symbol	Function Name	Input State	Description
12	EXT	External Trip	ON	When assigned input transitions OFF to ON, inverter latches trip event and displays E12
			OFF	No trip event for ON to OFF, any recorded trip events remain in history until Reset
Valid for inputs:		C_01, C_02, C_03, C_04, C_05, C_06		Example (requires input configuration—see page 3-34): 
Required settings:		(none)		
Notes:				
<ul style="list-style-type: none"> If the USP (Unattended Start Protection) feature is in use, the inverter will not automatically restart after cancelling the EXT trip event. In that case, it must receive either another Run command (OFF-to-ON transition), a keypad Reset command, or an [RS] intelligent terminal input signal. 				See I/O specs on page 4-6.

Unattended Start Protection

If the Run command is already set when power is turned ON, the inverter starts running immediately after powerup. The Unattended Start Protection (USP) function prevents that automatic startup, so that the inverter *will not* run without outside intervention. When USP is active and you need to reset an alarm and resume running, either turn the Run command OFF, or perform a reset operation by the terminal [RS] input or the keypad Stop/reset key.

In the figure below, the [UPS] feature is enabled. When the inverter power turns ON, the motor does not start, even though the Run command is already active. Instead, it enters the USP trip state, and displays E13 error code. This requires outside intervention to reset the alarm by turning OFF the Run command per this example (or applying a reset). Then the Run command can turn ON again and start the inverter output.

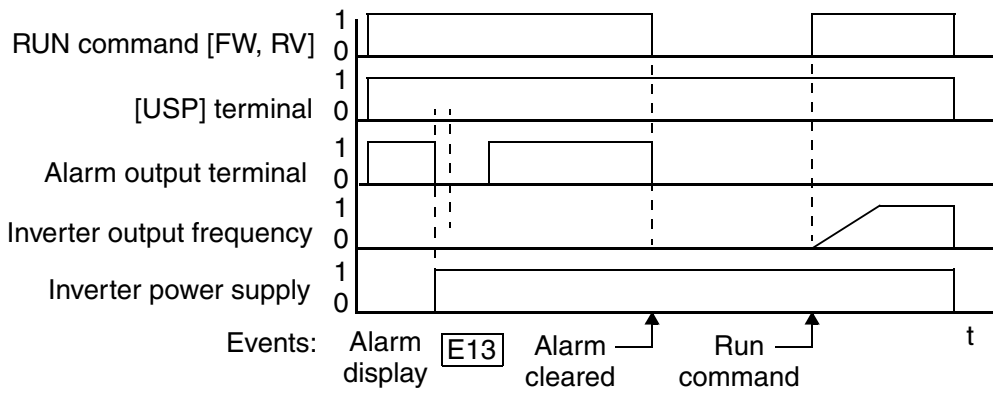

Option Code	Terminal Symbol	Function Name	Input State	Description
13	USP	Unattended Start Protection	ON	On powerup, the inverter will not resume a Run command (mostly used in the US)
			OFF	On powerup, the inverter will resume a Run command that was active before power loss
Valid for inputs:		C_01, C_02, C_03, C_04, C_05, C_06	Example (default input configuration shown for -FU models; -FE and -FR models require input configuration—see page 3-34): <div style="text-align: center;"> <p>The diagram shows a terminal block with terminals L, 6, 5, 4, 3, 2, 1, and P24. A switch is connected between terminal 4 and terminal P24.</p> </div>	
Required settings:		(none)		
Notes:		<ul style="list-style-type: none"> Note that when a USP error occurs and it is canceled by a reset from a [RS] terminal input, the inverter restarts running immediately. Even when the trip state is canceled by turning the terminal [RS] ON and OFF after an under voltage protection E09 occurs, the USP function will be performed. When the running command is active immediately after the power is turned ON, a USP error will occur. When this function is used, wait for at least three (3) seconds after the powerup to generate a Run command. 		

Operations and Monitoring

See I/O specs on page 4-6.

Software Lock

When the terminal [SFT] is turned ON, the data of all the parameters and functions (except the output frequency, depending on the setting of B_31) is locked (prohibited from editing). When the data is locked, the keypad keys cannot edit inverter parameters. To edit parameters again, turn OFF the [SFT] terminal input.

Use parameter B_31 to select whether the output frequency is excluded from the lock state or is locked as well.

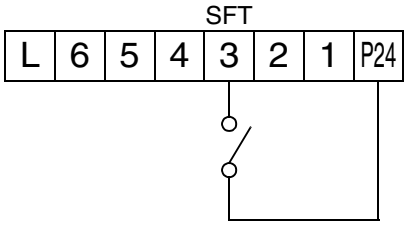
Option Code	Terminal Symbol	Function Name	Input State	Description
15	SFT	Software Lock	ON	The keypad and remote programming devices are prevented from changing parameters
			OFF	The parameters may be edited and stored
Valid for inputs:		C_01, C_02, C_03, C_04, C_05, C_06	Example (requires input configuration—see page 3-34):	
Required settings:		B_31 (excluded from lock)	 <p>See I/O specs on page 4-6.</p>	
Notes:		<ul style="list-style-type: none"> When the [SFT] terminal is turned ON, only the output frequency can be changed. Software lock can include the output frequency by setting B_31. Software lock by the operator is also possible without the [SFT] terminal being used (B_31). 		

Analog Input Current/Voltage Select

The [AT] terminal selects whether the inverter uses the voltage [O] or current [OI] input terminals for external frequency control. When intelligent input [AT] is ON, you can set the output frequency by applying a current input signal at [OI]-[L]. When the [AT] input is OFF, you can apply a voltage input signal at [O]-[L] to set the output frequency. Note that you must also set parameter A_01 = 01 to enable the analog terminal set for controlling the inverter frequency.

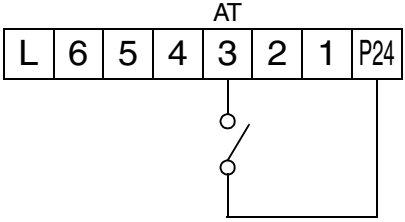
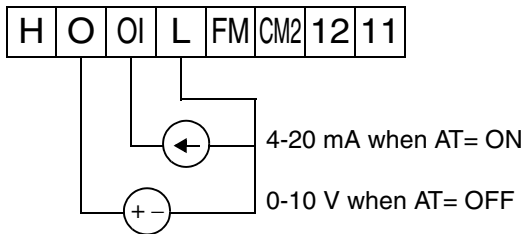
Option Code	Terminal Symbol	Function Name	Input State	Description
16	AT	Analog Input Voltage/current Select	ON	Terminal OI is enabled for current input (uses terminal L for power supply return)
			OFF	Terminal O is enabled for voltage input (uses terminal L for power supply return)
Valid for inputs:		C_01, C_02, C_03, C_04, C_05, C_06		Example (default input configuration shown for -FU models; -FE and -FR models require input configuration—see page 3-34): 
Required settings:		A_01 = 01		
Notes: <ul style="list-style-type: none"> • If the [AT] option is not assigned to any intelligent input terminal, then inverter uses the algebraic sum of both the voltage and current inputs for the frequency command (and A_01=01). • When using either the analog current and voltage input terminal, make sure that the [AT] function is allocated to an intelligent input terminal. • Be sure to set the frequency source setting A_01=01 to select the analog input terminals. 				
				 <p>See I/O specs on page 4-6.</p>

Reset Inverter

The [RS] terminal causes the inverter to execute the reset operation. If the inverter is in Trip Mode, the reset cancels the Trip state. When the signal [RS] is turned ON and OFF, the inverter executes the reset operation. The minimum pulse width for [RS] must be 12 ms or greater. The alarm output will be cleared within 30 ms after the onset of the Reset command.

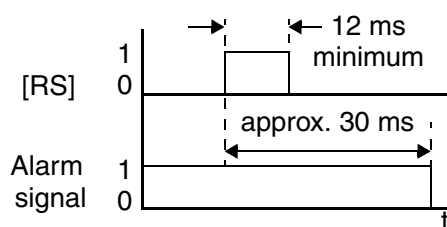

WARNING: After the Reset command is given and the alarm reset occurs, the motor will restart suddenly if the Run command is already active. Be sure to set the alarm reset after verifying that the Run command is OFF to prevent injury to personnel.

Option Code	Terminal Symbol	Function Name	Input State	Description
18	RS	Reset Inverter	ON	The motor output is turned OFF, the Trip Mode is cleared (if it exists), and powerup reset is applied
			OFF	Normal power-ON operation
Valid for inputs:		C_01, C_02, C_03, C_04, C_05, C_06		Example (default input configurations shown—see page 3-34):
Required settings:		(none)		
Notes:				
<ul style="list-style-type: none"> When the control terminal [RS] input is already ON at powerup for more than 4 seconds, the remote operator display is “R-ERROR COMM<2>” (the display of the digital operator is – – –. However, the inverter has no error. To clear the digital operator error, turn OFF the terminal [RS] input and press one of the operator keys. Pressing the Stop/Reset key of the digital operator can generate a reset operation only when an alarm occurs. A terminal configured with the [RS] function can only be configured for normally open operation. The terminal cannot be used in the normally closed contact state. When input power is turned ON, the inverter performs the same reset operation as it does when a pulse on the [RS] terminal occurs. The Stop/Reset key on the inverter is only operational for a few seconds after inverter powerup when a hand-held remote operator is connected to the inverter. If the [RS] terminal is turned ON while the motor is running, the motor will be free running (coasting). 				

Thermistor Thermal Protection

Motors that are equipped with a thermistor can be protected from overheating. Input terminal [5] has the unique ability to sense a thermistor resistance. When the resistance value of the thermistor connected to terminal [TH] (5) and [L] is more than 3 k Ohms $\pm 10\%$, the inverter enters the Trip Mode, turns OFF the output to the motor, and indicates the trip status E35. Use this function to protect the motor from overheating

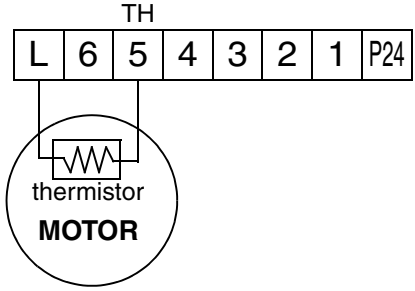
Option Code	Terminal Symbol	Function Name	Input State	Description
19	TH	Thermistor Thermal Protection	Sensor	When a thermistor is connected to terminals [5] and [L], the inverter checks for over-temperature and will cause trip (E35) and turn OFF the output to the motor
			Open	An open circuit in the thermistor causes a trip, and the inverter turns OFF the output
Valid for inputs:		C_05 only		Example (requires input configuration—see page 3-34): 
Required settings:		(none)		
Notes: <ul style="list-style-type: none"> Be sure the thermistor is connected to terminals [5] and [L]. If the resistance is above the threshold the inverter will trip. When the motor cools down enough, the thermistor resistance will change enough to permit you to clear the error. Press the STOP/Reset key to clear the error. 				

Remote Control Up and Down Functions

The [UP] [DWN] terminal functions can adjust the output frequency for remote control while the motor is running. The acceleration time and deceleration time of this function is same as normal operation ACC1 and DEC1 (2ACC1,2DEC1). The input terminals operate according to these principles:

- Acceleration - When the [UP] contact is turned ON, the output frequency accelerates from the current value. When it is turned OFF, the output frequency maintains its current value at that moment.
- Deceleration - When the [DWN] contact is turned ON, the output frequency decelerates from the current value. When it is turned OFF, the output frequency maintains its current value at that moment.

In the graph below, the [UP] and [DWN] terminals activate while the Run command remains ON. The output frequency responds to the [UP] and [DWN] commands.

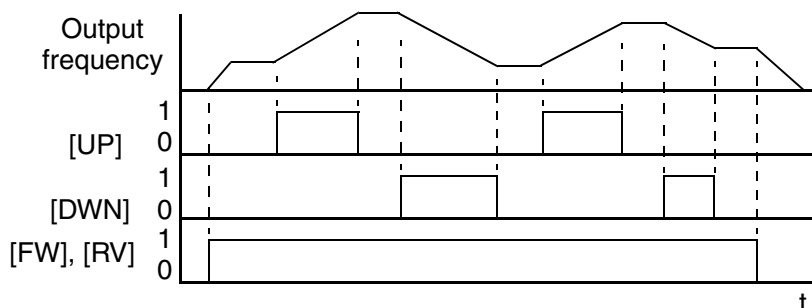

Option Code	Terminal Symbol	Function Name	Input State	Description
27	UP	Remote Control UP Function (motorized speed pot.)	ON	Accelerates (increases output frequency) motor from current frequency
			OFF	Output to motor operates normally
28	DWN	Remote Control DOWN Function (motorized speed pot.)	ON	Decelerates (decreases output frequency) motor from current frequency
			OFF	Output to motor operates normally
Valid for inputs:	C_01, C_02, C_03, C_04, C_05, C_06		Example (requires input configuration—see page 3-34):	
Required settings:	A_01 = 02		<p>See I/O specs on page 4-6.</p>	
Notes:	<ul style="list-style-type: none"> • This feature is available only when the frequency command source is programmed for operator control. Confirm A_01 is set to 02. • This function is not available when [JG] is in use. • The range of output frequency is 0 Hz to the value in A_04 (maximum frequency setting). 			
<ul style="list-style-type: none"> • The minimum ON time of [UP] and [DWN] is 50 ms. • This setting modifies the inverter speed from using F_01 output frequency setting as a starting point. 				

Using Intelligent Output Terminals

The intelligent output terminals are programmable in a similar way to the intelligent input terminals. The inverter has several output functions that you can assign individually to three physical logic outputs. Two of the outputs are open-collector transistors, and the third output is the alarm relay (form C – normally open and normally closed contacts). The relay is assigned the alarm function by default, but you can assign it to any of the functions that the open-collector outputs use.

Sinking Outputs, Open Collector

The open-collector transistor outputs can handle up to 50mA each. We highly recommend that you use an external power source as shown. It must be capable of providing at least 100mA to drive both outputs at full load. To drive loads that require more than 50mA, use external relay circuits as shown below.

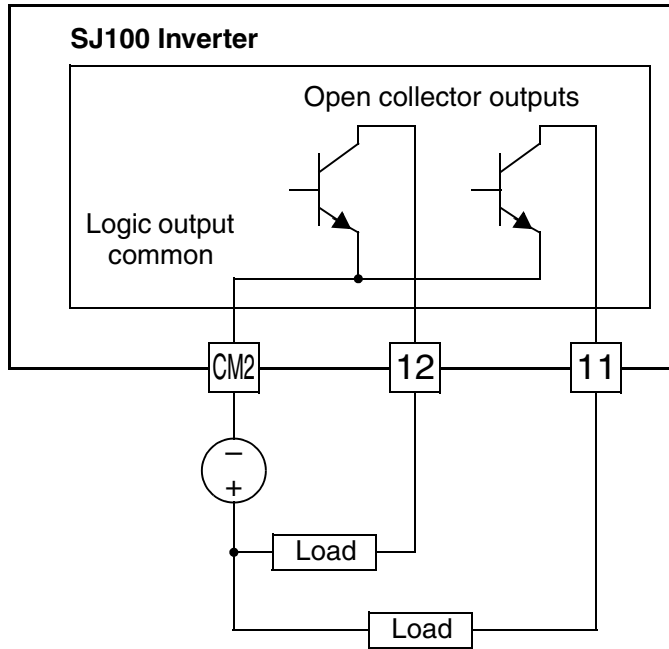

Sinking Outputs, Open Collector with External Relays

If you need output current greater than 50mA, use the inverter output to drive a small relay. Be sure to use a diode across the coil of the relay as shown (reverse-biased) in order to suppress the turn-off spike, or use a solid-state relay.

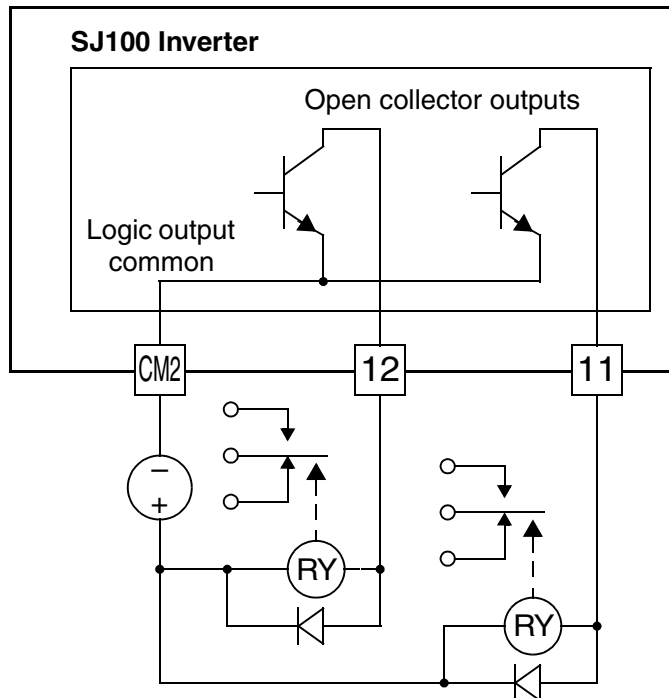

Run Signal

When the [RUN] signal is selected as an intelligent output terminal, the inverter outputs a signal on that terminal when it is in Run Mode. The output logic is active low, and is the open collector type (switch to ground).

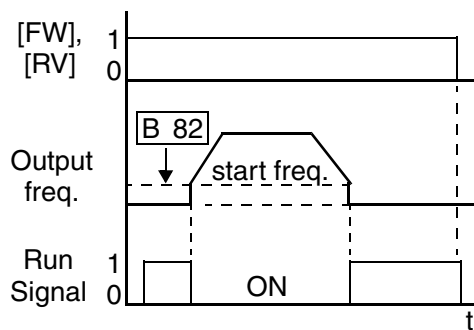

Option Code	Terminal Symbol	Function Name	Output State	Description
00	RUN	Run Signal	ON	when inverter is in Run Mode
			OFF	when inverter is in Stop Mode
Valid for outputs:		11, 12, AL0 – AL2		Example (default output configuration shown—see page 3-38):
Required settings:		(none)		
Notes:				
<ul style="list-style-type: none"> The inverter outputs the [RUN] signal whenever the inverter output exceeds the start frequency specified by parameter B_82. The start frequency is the initial inverter output frequency when it turns ON. 				See I/O specs on page 4-6.



NOTE: The example circuit in the table above drives a relay coil. Note the use of a diode to prevent the negative-going turn-off spike generated by the coil from damaging the inverter’s output transistor.

Frequency Arrival Signals

The *Frequency Arrival* group of outputs help coordinate external systems with the current velocity profile of the inverter. As the name implies, output [FA1] turns ON when the output *frequency arrives* at the standard set frequency (parameter F_01). Output [FA2] relies on programmable accel/ decel thresholds for increased flexibility. For example, you can have an output turn ON at one frequency during acceleration, and have it turn OFF at a different frequency during deceleration. All transitions have hysteresis to avoid output chatter if the output frequency is near one of the thresholds.

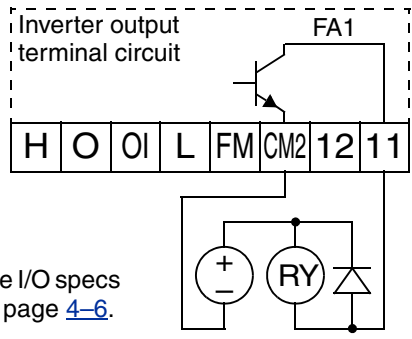
Option Code	Terminal Symbol	Function Name	Output State	Description
01	FA1	Frequency Arrival Type 1 – Constant Speed	ON	when output to motor is at the set frequency
			OFF	when output to motor is OFF, or in any acceleration or deceleration ramp
02	FA2	Frequency Arrival Type 2 – Over-frequency	ON	when output to motor is at or above the set frequency thresholds for, even if in acceleration or deceleration ramps
			OFF	when output to motor is OFF, or during acceleration or deceleration before the respective thresholds are crossed
Valid for outputs:		11, 12, AL0 – AL2		Example (default output configuration shown—see page 3-38): 
Required settings:		(none)		
Notes:				
<ul style="list-style-type: none"> For most applications you will need to use only one type of frequency arrival outputs (see examples). However, it is possible assign both output terminals to output functions [FA1] and [FA2]. For each frequency arrival threshold, the output anticipates the threshold (turns ON early) by 1.5Hz. The output turns OFF as the output frequency moves away from the threshold, delayed by 0.5Hz. The delay time of the output signal is 60 ms (nominal). 				



NOTE: The example circuit in the table above drives a relay coil. Note the use of a diode to prevent the negative-going turn-off spike generated by the coil from damaging the inverter’s output transistor.

Frequency arrival output [FA1] uses the standard output frequency (parameter F_01) as the threshold for switching. In the figure to the right, Frequency Arrival [FA1] turns ON when the output frequency gets within 0.5 Hz below or 1.5 Hz above the target constant frequency. This provides hysteresis that prevents output chatter near the threshold value. The hysteresis effect causes the output to turn ON slightly *early* as the speed approaches the threshold. Then the turn-OFF point is slightly *delayed*. The timing is further modified by a small 60 ms delay. Note the active low nature of the signal, due to the open collector output.

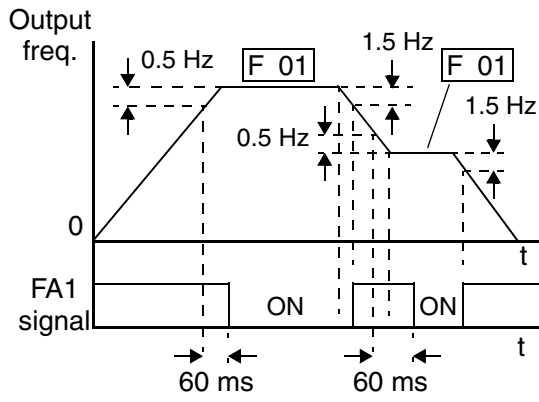

Frequency arrival output [FA2] works the same way; it just uses two separate thresholds as shown in the figure to the right. These provide for separate acceleration and deceleration thresholds to provide more flexibility than for [FA1]. [FA2] uses C_42 during acceleration for the ON threshold, and C_43 during deceleration for the OFF threshold. This signal also is active low and has a 60 ms delay after the frequency thresholds are crossed. Having different accel and decel thresholds provides an asymmetrical output function. However, you can use equal ON and OFF thresholds, if desired.

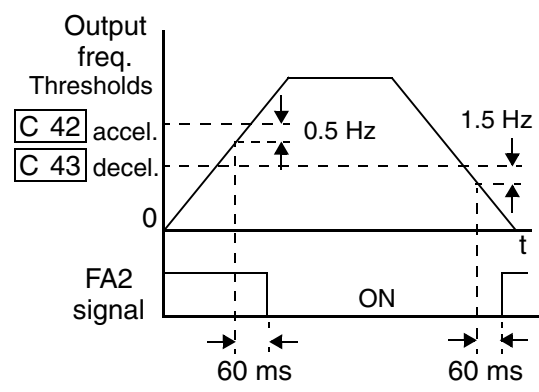

Overload Advance Notice Signal

When the output current exceeds a preset value, the [OL] terminal signal turns ON. The parameter C_41 sets the overload threshold. The overload detection circuit operates during powered motor operation and during regenerative braking. The output circuits use open-collector transistors, and are active low.

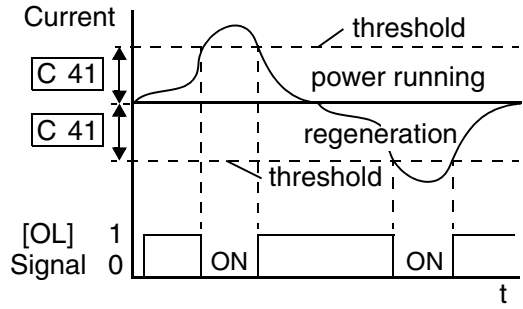

Option Code	Terminal Symbol	Function Name	Output State	Description
03	OL	Overload Advance Notice Signal	ON	when output current is more than the set threshold for the overload signal
			OFF	when output current is less than the set threshold for the overload signal
Valid for outputs:		11, 12, AL0 – AL2		Example (requires output configuration—see page 3-38):
Required settings:		C_41		
Notes: <ul style="list-style-type: none"> The default value is 100%. To change the level from the default, set C_41 (overload level). The accuracy of this function is the same as the function of the output current monitor on the [FM] terminal (see “Analog and Digital Monitor Output” on page 4-33). 				
				See I/O specs on page 4-6.



NOTE: The example circuit in the table above drives a relay coil. Note the use of a diode to prevent the negative-going turn-off spike generated by the coil from damaging the inverter’s output transistor.

Output Deviation for PID Control

The PID loop error is defined as the magnitude (absolute value) of the difference between the Setpoint (target value) and the Process Variable (actual value). When the error magnitude exceeds the preset value for C_44, the [OD] terminal signal turns ON. Refer to [“PID Loop Operation” on page 4-39](#).

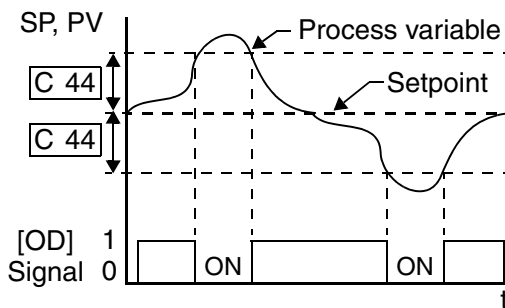

Option Code	Terminal Symbol	Function Name	Output State	Description
04	OD	Output Deviation for PID Control	ON	when PID error is more than the set threshold for the deviation signal
			OFF	when PID error is less than the set threshold for the deviation signal
Valid for outputs:		11, 12, AL0 – AL2		Example (requires output configuration—see page 3-38):
Required settings:		C_44		
Notes:				
<ul style="list-style-type: none"> The default difference value is set to 3%. To change this value, change parameter C_44 (deviation level). 				

See I/O specs on page 4-6.



NOTE: The example circuit in the table above drives a relay coil. Note the use of a diode to prevent the negative-going turn-off spike generated by the coil from damaging the inverter’s output transistor.

Alarm Signal

The inverter alarm signal is active when a fault has occurred and it is in the Trip Mode (refer to the diagram at right). When the fault is cleared the alarm signal becomes inactive.

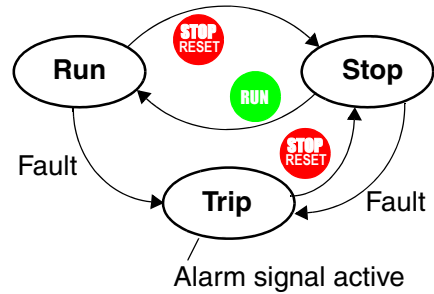

We must make a distinction between the alarm *signal* AL and the alarm relay *contacts* [AL0], [AL1] and [AL2]. The signal AL is a logic function, which you can assign to the open collector output terminals [11] or [12] or the relay

outputs. The most common (and default) use of the relay is for AL, thus the labeling of its terminals. Use an open collector output (terminal [11] or [12]) for a low-current logic signal interface or to energize a small relay (50 mA maximum). Use the relay output to interface to higher voltage and current devices (10 mA minimum).

Option Code	Terminal Symbol	Function Name	Output State	Description
05	AL	Alarm Signal	ON	when an alarm signal has occurred and has not been cleared
			OFF	when no alarm has occurred since the last clearing of alarm(s)
Valid for outputs:		11, 12, AL0 – AL2		Example for terminal [11] or [12] (requires output configuration—see page 3-38):
Required settings:		C_24, C_33		
Notes: <ul style="list-style-type: none"> When the alarm output is set to normally closed, a time delay of less than 2 seconds occurs until the contact is closed when the power is turned ON. Terminals [11] and [12] are open collector outputs, so the electric specifications of [AL] are different from the contact output terminals [AL0], [AL1], [AL2]. When the inverter power supply is turned OFF, the alarm signal output is valid as long as the external control circuit has power. This signal output has the delay time (300 ms nominal) from the fault alarm output. The relay contact specifications are in “Specifications of Control and Logic Connections” on page 4-6. The contact diagrams for different conditions are on the next page. 				
				Example for terminals [AL0], [AL1], [AL2] (default output configuration shown—see page 3-38):
				See I/O specs on page 4-6.

The alarm output terminals are connected as shown below (left) by default. The contact logic can be inverted as shown (below right) by using the parameter setting C_33. The relay contacts normally open (N.O.) and normally closed (N.O.) convention uses “normal” to mean the inverter has power and is in Run or Stop Mode. The relay contacts switch to the opposite position when it is in Trip Mode or when input power is OFF.

N.C. contacts (after initialization)					N.O. contact (inverted by C_33 setting)				
During normal running		When an alarm occurs or power is turned OFF			During normal running		When an alarm occurs or power is turned OFF		
Contact	Power	Run State	AL0-AL1	AL0-AL2	Contact	Power	Run State	AL0-AL1	AL0-AL2
N.C. (after initialize, C_33=01)	ON	Normal	Closed	Open	N.O. (set C_33=00)	ON	Normal	Open	Closed
	ON	Trip	Open	Closed		ON	Trip	Closed	Open
	OFF	—	Open	Closed		OFF	—	Open	Closed

Analog Input Operation

The SJ100 inverters provide for analog input to command the inverter frequency output value. The analog input terminal group includes the [L], [OI], [O], and [H] terminals on the control connector, which provide for Voltage [O] or Current [OI] input. All analog input signals must use the analog ground [L].

If you use either the voltage or current analog input, you must select one of them using the logic input terminal function [AT] analog type. If terminal [AT] is OFF, the voltage input [O] can command the inverter output frequency. If terminal [AT] is ON, the current input [OI] can command the inverter output frequency. The [AT] terminal function is covered in [“Analog Input Current/Voltage Select” on page 4-20](#). Remember that you must also set A_01 = 01 to select analog input as the frequency source.

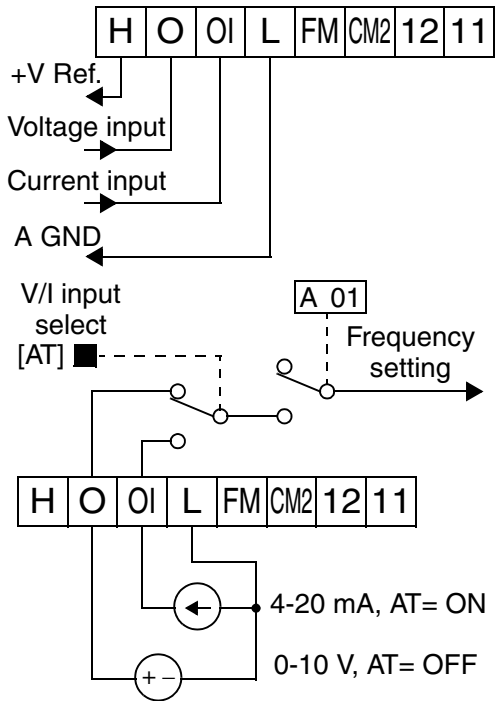

NOTE: If no logic input terminal is configured for the [AT] function, then inverter sums the voltage and current input to determine the desired input value.

Using an external potentiometer is a common way to control the inverter output frequency (and a good way to learn how to use the analog inputs). The potentiometer uses the built-in 10V reference [H] and the analog ground [L] for excitation, and the voltage input [O] for the signal. By default, the [AT] terminal selects the voltage input when it is OFF. Take care to use the proper resistance for the potentiometer, which is 1 to 2 k Ohms, 2 Watts.

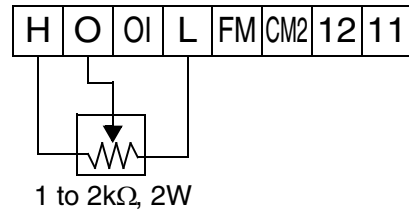

Voltage Input – The voltage input circuit uses terminals [L] and [O]. Attach the signal cable’s shield wire only to terminal [L] on the inverter. Maintain the voltage within specifications (do not apply negative voltage).

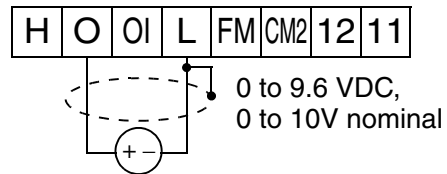

Current Input – The current input circuit uses terminals [OI] and [L]. The current comes from a *sourcing* type transmitter; a *sinking* type will not work! This means the current must flow into terminal [OI], and terminal [L] is the return back to the transmitter. The input impedance from [OI] to [L] is 250 Ohms. Attach the cable shield wire only to terminal [L] on the inverter.

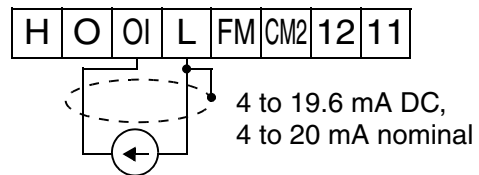

See I/O specs on page 4-6.

Analog and Digital Monitor Output

In the system design for inverter applications it is useful to monitor the inverter operation from a remote location. In some cases, this requires only a panel-mounted analog meter (moving-coil type). In other cases, a controller device such as a PLC may command the inverter frequency and other functions. Sometimes it is useful to have the inverter transmit the (real-time) output frequency value back to the controller to confirm actual operation. The monitor output function [FM] serves these purposes.

The inverter provides an analog/digital output primarily for frequency monitoring on terminal [FM] (frequency monitor). It uses terminal [L] as analog GND reference. You can configure terminal [FM] to transmit the inverter current output or frequency output in *pulse-width modulated* format (PWM). You can also configure terminal [FM] to output the frequency value in a *frequency-modulated* (FM) format.

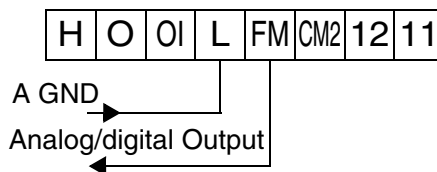

See I/O specs on page 4-6.

The following table lists terminal [FM] configurations. Use function C_23 to configure.

Func.	Code	Description	Waveform	Full Scale value
C_23	00	Output frequency	PWM	0 – Max. frequency (Hz)
	01	Output current	PWM	0 – 200%
	02	Output frequency	FM	0 – Max. frequency (Hz)

PWM Signal Type

The pulse-width modulated signal at terminal [FM] is primarily designed for driving a moving-coil meter. The PWM signal is automatically averaged by the inertia of the moving-coil mechanism—converting the PWM signal to an analog representation. Be sure to use a 10V full-scale DC voltmeter.

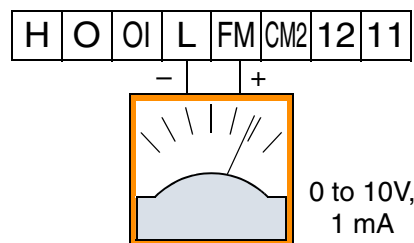

The signal characteristics of terminal [FM] in PWM configuration is shown below:

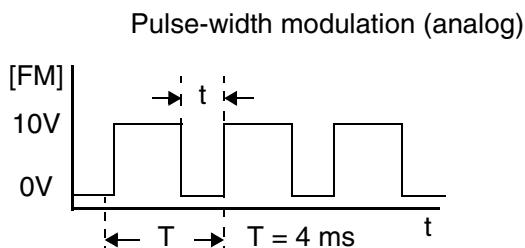

$$[FM] \text{ Output} = \frac{t}{T}$$

- C_23 = 00** Inverter output frequency
- C_23 = 01** Inverter output current
- B_81** PWM scale factor

To calibrate the meter reading, generate a full-scale output (always ON) at terminal [FM]. Then use parameter B_81 (gain setting from 0 to 255) to adjust the corresponding full-scale reading of the meter. For example, when the inverter output frequency is 60 Hz, change the value of B_81 so that the meter reads 60 Hz.



TIP: When using the analog meter for monitoring, adjust the meter so it has a zero reading when the [FM] output is zero. Then use scale factor B_81 to adjust the [FM] output so the maximum frequency in the inverter corresponds to a full-scale reading on the meter.

The following accuracy notes apply for PWM monitor outputs:

- The monitor accuracy for frequency monitoring after adjustment is about $\pm 5\%$. Depending on the motor, the accuracy may exceed this value.
- The monitor display accuracy for current (normally $\pm 20\%$, depending on the connected motor's characteristics) can be improved by adjusting parameter B_32.
- The accuracy of the current reading is given by the equation:

$$\frac{I_{mc} - I_m}{I_r} \times 100 \leq \pm 20\%$$

I_m = Inverter output current (measured)
 I_{mc} = Monitor display current
 I_r = Inverter rated current

- If precise current measurement is necessary, use the moving-coil type ammeter between the inverter and the motor.

PWM Smoothing Circuit – You may also wish to smooth the PWM signal at the [FM] terminal and convert it to an analog signal. The [FM] terminal will then generate a relatively stable DC analog voltage that represents the output value. To do this, use the circuit shown to the right. Note the output impedance of the circuit is at least $82k\Omega$, so the monitoring device needs an input impedance of $1M\Omega$ or greater. Otherwise, the impedance of the smoothing circuit will cause a non-linearity in the reading.

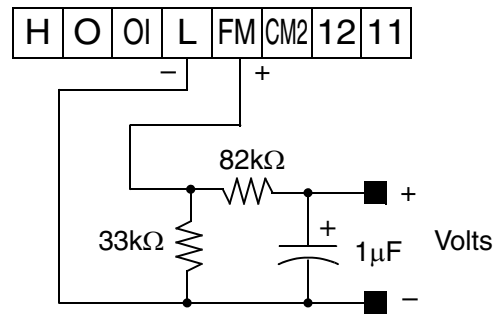

See I/O specs on page 4-6.

FM Signal Type

The *frequency-modulated* output at terminal [FM] varies its frequency with the inverter output frequency (C_23=03). The multiplier is 10, such that the maximum [FM] signal frequency is $10 \times 360 = 3.6$ kHz, or 10 times the inverter's maximum output frequency. The signal at [FM] uses the parameter A_04 *Maximum frequency setting*. For example, if A_04 = 60 Hz, then the maximum signal value at [FM] will be $10 \times 60 = 600$ Hz. This frequency is digitally controlled for accuracy, and does not use the B_81 gain setting when C_23=03 (frequency modulation selection).

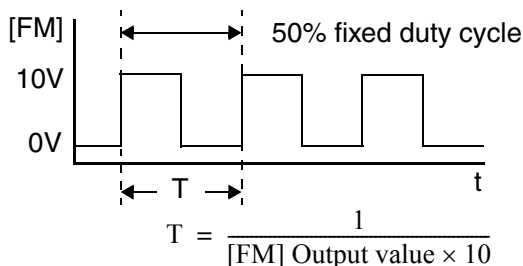

$$[FM] \text{ Output value} = \frac{1}{T \times 10}$$

C_23 = 02 Selects FM type output

Auto-tuning for Sensorless Vector Control

The SJ100 inverter has a built-in auto-tuning algorithm. Its purpose is to detect and record the motor parameters to use in sensorless vector control. As you may recall from Chapter 3, sensorless vector control (SLV) is the more sophisticated control algorithm the SJ100 inverter can use to deliver higher torque levels at different speeds. Using parameter A_44, you can select from the following:

- 00 = Variable frequency with constant torque
- 01 = Variable frequency with reduced torque
- 02 = Sensorless vector control (SLV)



NOTE: Although “auto-tuning” is often associated with PID loops, the PID loop in the SJ100 inverter is not directly affected by the auto-tuning procedure or parameters.

Most of the “H” Group parameters are dedicated to storing SLV parameters. The inverter comes from the factory with default settings for these parameters. To benefit fully from SLV control, you must use A_44 to select SLV control, and initiate the auto-tuning calibration procedure as described below for your motor. During the procedure, the inverter will write new values for the “H” Group settings related to SLV control. The settings have a second set of parameters for a second motor. The factory default configuration will apply auto-tuning to the first motor.



WARNING: You may need to disconnect the load from the motor before performing auto-tuning. The inverter runs the motor forward and backward for several seconds without regard to load movement limits.

Follow the steps below to auto-tune the inverter (table continued on next page):

Step	Parameter		Parameter Setting or Action	Notes
	Code	Name		
1	F_02	Acceleration (1)	Set to a time greater than 10 seconds	Parameters F_02 and F_03 must be equal in order for the moment of inertia data to be correct. Increase the time if over-current or over-voltage trip event occurs.
2	F_03	Deceleration (1)	Set the same as setting F_02	
3	H_03	Motor capacity	Varies with inverter (default value will be correct)	Setting is in kW
4	H_04	Motor poles setting	Set the poles 2 / 4 / 6 / 8 to match motor	Refer to the motor specifications label
5	A_01	Frequency source setting	Set = 02 (selects parameter F_01 as source of output frequency)	The auto-tuning procedure will automatically control the speed
6	A_03	Base frequency setting	Set = 50 or 60 for your motor	Default= 50 (Europe) / 60(US)
7	A_20	Multi-speed frequency setting	Set A_20 > 0	If A_20 = 0, auto-tuning is not performed

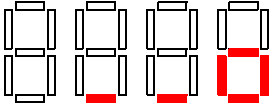
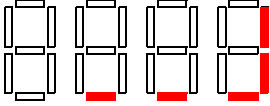
Step	Parameter		Parameter Setting or Action	Notes
	Code	Name		
8	A_82	AVR voltage select	Select output voltage for motor 200V class: 200/220/230/240 400V class: 380/400/415/440/ 460	Voltage setting cannot be greater than input voltage
9	A_51	DC braking enable	Set = 00 to disable DC braking	Default = 00 (disabled)
10	H_01	Auto-tuning Setting	Set = 01 (full auto-tuning Set = 02 (partial auto-tuning – measures resistance and inductance only)	Try using H_01 = 01, if possible. If application or load interferes with or prohibits motor rotation, then use H_01 = 02.
11	—	—	Press the RUN key on the keypad and wait for the test to complete	The inverter actions are: A) .. AC excitation (no rotation) B)... DC excitation (no rotation) C)... Motor accelerates to 80% of base frequency, then stops. D) Motor accelerates to A20 setting frequency, then stops.
12	—	—	Interpret results by reading the display pattern	Auto-tuning process completed steps A) to D)  Auto-tuning failed at step A) or B) 
13	—	—	Reset Inverter by pressing the Stop/Reset Key	Inverter will display alternating pattern on the display and return to parameter menu. Auto-tuning will be OFF. Make any corrections and start again at step 10.



NOTE: During step 11, the motor will make a slight humming sound during the AC and DC excitation (A and B) steps of the auto-tuning process. This sound is normal.



NOTE: When the SLV control method is selected with A_44 (F-04), set the carrier frequency to 2.1 kHz or higher with B_83.

If the inverter drives a motor/load with a small inertia, the motor may exhibit “hunting” during running. If this occurs, take the following corrective steps:

1. Adjust the stabilization constant H_06/H206.
2. Decrease the carrier frequency B_83, but not below 2.1 kHz.
3. Set the Automatic Voltage Regulation (AVR) function A_81 to the OFF setting (disabled = 01).

If the desired characteristic cannot be obtained in sensorless vector controlled operation with standard (factory default) or auto-tuning data, adjust the motor constant(s) according to the observed symptoms shown below.

Operation Status	Symptom	Adjustment	Parameter
Powered running (status with an accelerating torque)	When low frequency (a few Hz) torque is insufficient	Increase the motor speed constant R1 in relation to auto-tuning data, step by step, within 1 to 1.2 times R2.	H_20 / H_30 / H220/ H230
	When the speed fluctuation coefficient becomes negative	Increase the motor constant R2 in relation to auto-tuning data, step by step, within 1 to 1.2 times R2.	H_21 / H_32 / H221 / H231
	When the speed fluctuation coefficient becomes positive	Decrease the motor constant R2 in relation to auto-tuning data, step by step, within 0.8 to 1 times R2.	H_21 / H_32 / H221 / H231
Regeneration (status with a decelerating torque)	When low frequency (a few Hz) torque is insufficient	Increase the motor speed constant R1 in relation to auto-tuning data, step by step, within 1 to 1.2 times R1.	H_20 / H_30 / H220/ H230
		Increase the motor constant R2 in relation to auto-tuning data, step by step, within 1 to 1.2 times R2.	H_21 / H_32 / H221 / H231
		Decrease the carrier frequency set value.	B_83

- Note 1:** If the inverter is using sensorless vector control and the motor is more than one frame size smaller than the maximum applicable motor, then the motor characteristic values may not be satisfactory.
- Note 2:** No sensorless vector control operation is possible if two or more motors are connected (parallel operation).
- Note 3:** When the auto-tuning function is executed in the state that the DC braking is set, the motor constants will not be accurately set. Therefore, disable DC braking and then start the auto-tuning procedure again.
- Note 4:** When accelerating or speeding up is not to be performed in the auto-tuning step for accelerating up to 80% of the base frequency, lower the set value of manual torque boost.
- Note 5:** Be sure the motor is stopped before you carry out an auto-tuning procedure. Auto-tuning data that is derived while the motor is still running may not be correct.

Note 6: Do not interrupt an auto-tuning procedure by removing power or by using the Stop command, unless it is emergency. If this does occur, initialize the inverter's parameters to the factory default settings (see [“Restoring Factory Default Settings” on page 6-8](#)). Then reprogram the parameters unique to your application, and initiate the auto-tuning procedure again.



NOTE: When the data of the H Group parameters does not match that of the motor, satisfactory characteristics may not be obtained during sensorless vector operation. Also, the stabilization adjustment (H_06) is effective for V/f settings (00 and 01). The full performance may not be achieved if the rating of a motor used is more than one frame size smaller than the maximum applicable rating when the sensorless vector function is used. You must disable sensorless vector operation when two or more motors are connected. For the motor stabilization, set this data properly for the H_03 (H203) parameter according to the motor used if its rating is not the same as the maximum applicable rating in V/f operation.

PID Loop Operation

In standard operation, the inverter uses a reference source selected by parameter A_01 for the output frequency, which may be a fixed value (F_01), a variable set by the front panel potentiometer, or value from an analog input (voltage or current). To enable PID operation, set A_71 = 01. This causes the inverter to *calculate* the target frequency, or setpoint.

A calculated target frequency can have a lot of advantages. It lets the inverter adjust the motor speed to optimize some other process of interest, potentially saving energy as well. Refer to the figure below. The motor acts upon the external process. To control that external process, the inverter must monitor the process variable. This requires wiring a sensor to either the analog input terminal [O] (voltage) or terminal [OI] (current).

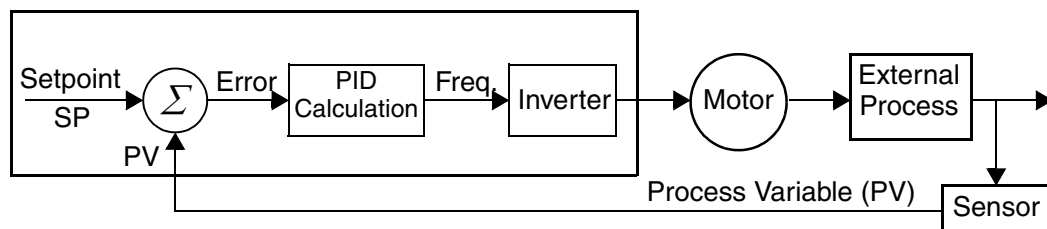

When enabled, the PID loop calculates the ideal output frequency to minimize the loop error. This means we no longer command the inverter to run at a particular frequency, but we specify the ideal value for the process variable. That ideal value is called the *setpoint*, and is specified in the units of the external process variable. For a pump application it may be gallons/minute, or it could be air velocity or temperature for an HVAC unit. Parameter A_75 is a scale factor that relates the external process variable units to motor frequency. The figure below is a more detailed diagram of the PID function.

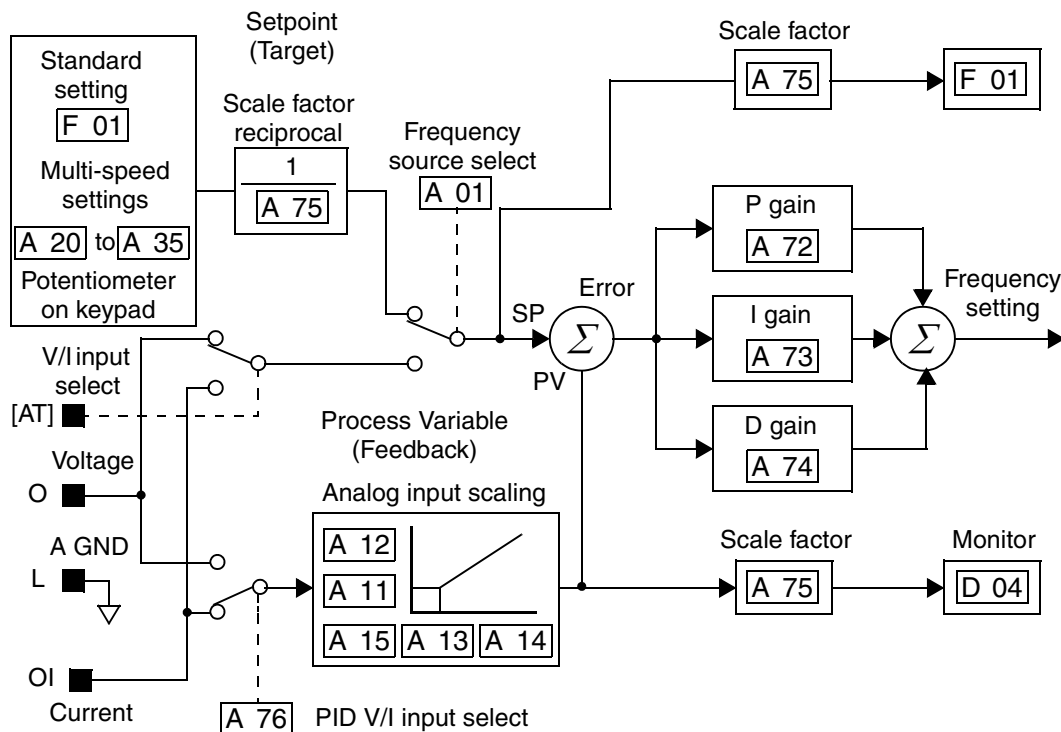

Operations and Monitoring

Configuring the Inverter for Multiple Motors

Simultaneous Connections

For some applications, you may need to connect two or more motors (wired in parallel) to a single inverter's output. For example, this is common in conveyor applications where two separate conveyors need to have approximately the same speed. The use of two motors may be less expensive than making the mechanical link for one motor to drive multiple conveyors.

Some of the characteristics of using multiple motors with one drive are:

- Use only V/f (voltage-frequency) control; do not use SLV (sensorless vector control).
- The inverter output must be rated to handle the sum of the currents from the motors.
- You must use separate thermal protection switches or devices to protect each motor. Locate the device for each motor inside the motor housing or as close to it as possible.
- The wiring for the motors must be permanently connected in parallel (do not remove one motor from the circuit during operation).

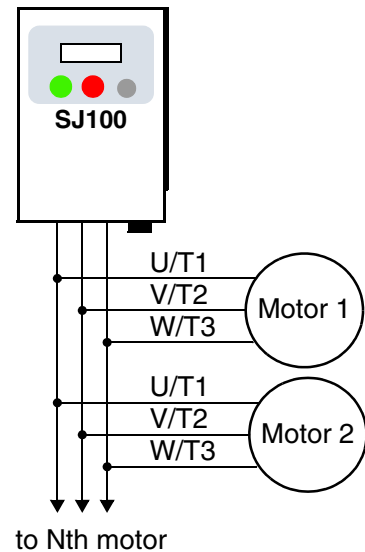

NOTE: The motor speeds are identical only in theory. That is because slight differences in their loads will cause one motor to slip a little more than another, even if the motors are identical. Therefore, do not use this technique for multi-axis machinery that must maintain a fixed position reference between its axes.

Inverter Configuration for Two Motor Types

Some equipment manufacturers may have a single type of machine that has to support two different motor types—and only one motor will be connected at a time. For example, an OEM may sell basically the same machine to the US market and the European market. Some reasons why the OEM needs two motor profiles are:

- The inverter power input voltage is different for these markets.
- The required motor type is also different for each destination.

In other cases, the inverter needs two profiles because the machine characteristics vary according to these situations:

- Sometimes the motor load is very light and can move fast. Other times the motor load is heavy and must move slower. Using two profiles allows the motor speed, acceleration and deceleration to be optimal for the load and avoid inverter trip (fault) events.
- Sometimes the slower version of the machine does not have special braking options, but a higher performance version does have braking features.

Having two motor profiles lets you store two “personalities” for motors in one inverter’s memory. The inverter allows the final selection between the two motor types to be made in the field through the use of an intelligent input terminal function [SET]. This provides an extra level of flexibility needed in particular situations. See the following table.

Parameters for the second motor have a function code of the form x2xx. They appear immediately after the first motor’s parameter in the menu listing order. The following table lists the parameters that have the second parameter register for programming.

Function Name	Parameter Codes	
	1st motor	2nd motor
Multi-speed frequency setting	A_20	A220
Acceleration (1) time setting	F_02	F202
Deceleration (1) time setting	F_03	F203
Acceleration (2) time setting	A_92	A292
Deceleration (2) time setting	A_93	A293
Select method to use Acc2/Dec2	A_94	A294
Acc1 to Acc2 frequency transition point	A_95	A295
Dec1 to Dec2 frequency transition point	A_96	A296
Level of electronic thermal setting	B_12	B212
Electronic thermal characteristic	B_13	B213
Torque boost method selection	A_41	A241
Manual torque boost value	A_42	A242
Manual torque boost frequency adjustment	A_43	A243
V/f characteristic curve selection	A_44	A244
Base frequency setting	A_03	A203
Maximum frequency setting	A_04	A204
Motor data selection	H_02	H202
Motor capacity	H_03	H203
Motor poles setting	H_04	H204
Motor constant R1	H_20/H_30	H220/H230
Motor constant R2	H_21/H_31	H221/H231
Motor constant L	H_22/H_32	H222/H232
Motor constant I _o	H_23/H_33	H223/H233
Motor constant J	H_24/H_34	H224/H234
Motor speed constant	H_05	H205
Motor stabilization constant	H_06	H206

Inverter System Accessories



In This Chapter....	page
— Introduction	2
— Component Descriptions	3
— Dynamic Braking	5

Introduction

A motor control system will obviously include a motor and inverter, as well as fuses for safety. If you are connecting a motor to the inverter on a test bench just to get started, that's all you may need for now. But a fully developed system can also have a variety of additional components. Some can be for noise suppression, while others may enhance the inverter's braking performance. The figure below shows a system with several possible optional components, and the table gives part number information.

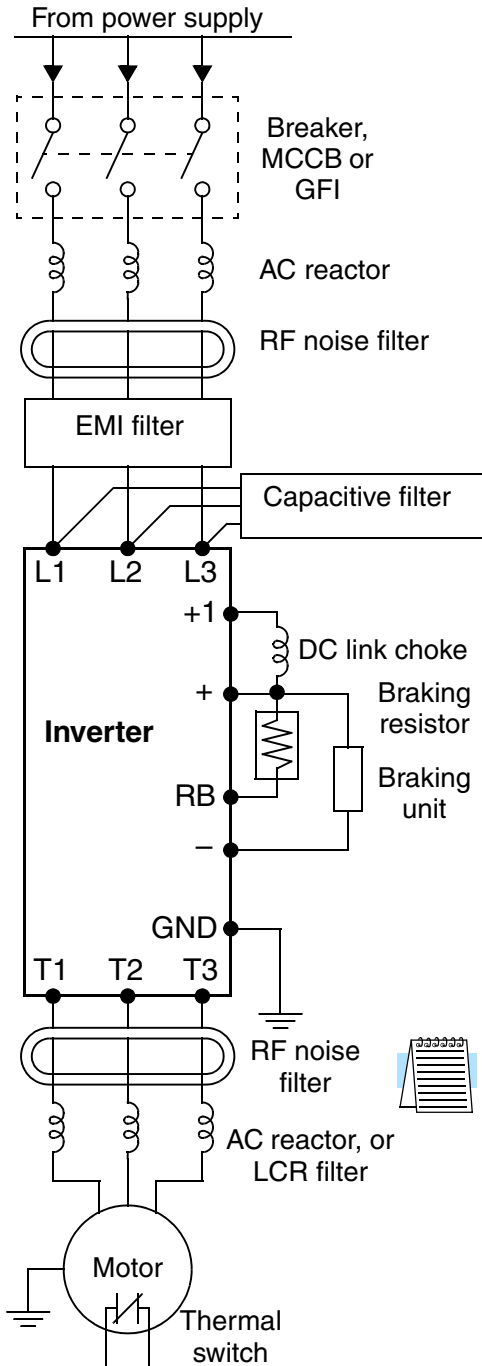

Name	Part No. Series		See page
	Europe, Japan	USA	
AC reactor, input side	ALI-xxx2	HRL-x	5-3
RF noise filter, input side	ZCL-xxx	ZCL-xxx	5-4
EMI filter (for CE)	FFL100-xxx	FFL100-xxx	5-4
Capacitive filter	CFI-x	CFI-x	5-4
DC link choke	DCL-x-xx	HDC-xxx	5-4
Braking resistor	JRB-xxx-x SRB-xxx-x	JRB-xxx-x SRB-xxx-x	5-5
Braking resistor, NEMA-rated	—	HRB-x, NSRBx00-x NJRB-xxx	5-5
Resistance braking unit	BRD-xxx	BRD-xxx	5-5
RF noise filter, output side	ZCL-xxx	ZCL-xxx	5-4
AC reactor, output side	ALI-x2-xxx	HRL-xxx	5-3
LCR filter	Combination: ALI-x2-xxx LPF-xxx R-2-xxx	HRL-xxC	5-3

Note: The Hitachi part number series for accessories includes different sizes of each part type, specified by the -x suffix. Hitachi product literature can help match size and rating of your inverter to the proper accessory size.

Each inverter accessory comes with its own printed instruction manual. Please refer to those manuals for complete installation details. This chapter gives only an overview of these optional system devices.

Component Descriptions

AC Reactors, Input Side

This is useful in suppressing harmonics induced on the power supply lines, or when the main power voltage imbalance exceeds 3% (and power source capacity is more than 500 kVA), or to smooth out line fluctuations. It also improves the power factor.

In the following cases for a general-purpose inverter, a large peak current flows on the main power supply side, and is able to destroy the inverter module:

- If the unbalanced factor of the power supply is 3% or higher
- If the power supply capacity is at least 10 times greater than the inverter capacity (the power supply capacity is 500 kVA or more)
- If abrupt power supply changes are expected

Examples of these situations include:

1. Several inverters are connected in parallel, sharing the same power bus
2. A thyristor converter and an inverter are connected in parallel, sharing the same power bus
3. An installed phase-advance (power factor correction) capacitor opens and closes

Where these conditions exist or when the connected equipment must be highly reliable, you **MUST** install an input-side AC reactor of 3% (at a voltage drop at rated current) with respect to the supply voltage on the power supply side. Also, where the effects of an indirect lightning strike are possible, install a lightning conductor.

Example calculation:

$$V_{RS} = 205\text{V}, V_{ST} = 203\text{V}, V_{TR} = 197\text{V},$$

where V_{RS} is R-S line voltage, V_{ST} is S-T line voltage, V_{TR} is T-R line voltage

$$\begin{aligned} \text{Unbalance factor of voltage} &= \frac{\text{Max. line voltage (min.)} - \text{Mean line voltage}}{\text{Meanline voltage}} \times 100 \\ &= \frac{V_{RS} - (V_{RS} + V_{ST} + V_{TR})/3}{(V_{RS} + V_{ST} + V_{TR})/3} \times 100 = \frac{205 - 202}{202} \times 100 = 1.5\% \end{aligned}$$

Please refer to the documentation that comes with the AC reactor for installation instructions.

AC Reactors, Output Side

This reactor reduces the vibrations in the motor caused by the inverter's switching waveforms, by smoothing the waveforms to approximate commercial power quality. It is also useful to reduce the reflected voltage wave phenomenon when wiring from the inverter to the motor is more than 10m in length. Please refer to the documentation that comes with the AC reactor for installation instructions.

Zero-phase Reactor (RF Noise Filter)

The zero-phase reactor helps reduce radiated noise from the inverter wiring. It can be used on the input or output side of the inverter. The example zero-phase reactor shown to the right comes with a mounting bracket. The wiring must go through the opening to reduce the RF component of the electrical noise. Loop the wires three times (four turns) to attain the full RF filtering effect. For larger wire sizes, place multiple zero-phase reactors (up to four) side-by-side for a greater filtering effect.



ZCL-xxx

EMI Filter

The EMI filter reduces the conducted noise on the power supply wiring generated by the inverter. Connect the EMI filter to the inverter primary (input side). The FFL100 series filter is required for compliance to the EMC Class A directive (Europe) and C-TICK (Australia). See [“CE-EMC Installation Guidelines” on page C-2](#).



WARNING: The EMI filter has high internal leakage current from power wiring to the chassis. Therefore, connect the chassis ground of the EMI filter before making the power connections to avoid danger of shock or injury.

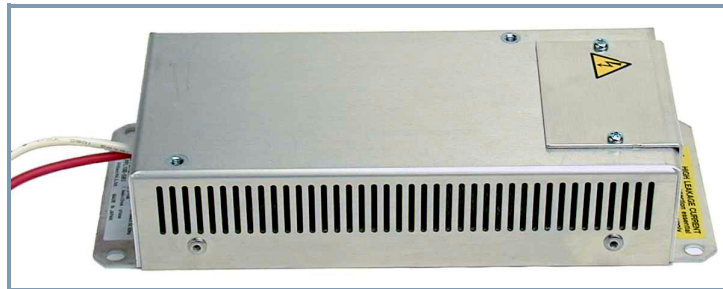

FFL100-xxx

RF Noise Filter (Capacitive)

This capacitive filter reduces radiated noise from the main power wires in the inverter input side. This filter is not for achieving CE compliance and is applicable to the input side only of the inverter. It comes in two versions—for 200V class inverters or 400V class inverters. Please refer to the documentation that comes with the radio noise filter for installation instructions.

DC Link Choke

The DC choke (reactor) suppresses harmonics generated by the inverter. It attenuates the high-frequency components on the inverter’s internal DC bus (link). However, note that it does not protect the diode rectifiers in the inverter input circuit.

Dynamic Braking

Introduction

The purpose of dynamic braking is to improve the ability of the inverter to stop (decelerate) the motor and load. This becomes necessary when an application has some or all of the following characteristics:

- High load inertia compared to the available motor torque
- The application requires frequent or sudden changes in speed
- System losses are not great enough to slow the motor as needed

When the inverter reduces its output frequency to decelerate the load, the motor can temporarily become a generator. This occurs when the motor rotation frequency is higher than the inverter output frequency. This condition can cause the inverter DC bus voltage to rise, resulting in an over-voltage trip. In many applications, the over-voltage condition serves as a warning signal that we have exceeded the deceleration capabilities of the system. SJ100 inverters have a built-in braking unit, which sends the regenerative energy from the motor during deceleration to the optional braking resistor(s). External braking units may also be used if higher braking torques and/or duty cycles are required. The dynamic braking resistor serves as a load, developing heat to stop the motor just as brakes on an automobile develop heat during braking.

The braking resistor is the main component of a braking resistor assembly that includes a fuse and thermally activated alarm relay for safety. However, be careful to avoid overheating its resistor. The fuse and thermal relay are safeguards for extreme conditions, but the inverter can maintain braking usage in a safe zone.



Braking Resistor

Dynamic Braking Usage Ratio

The inverter controls braking via a duty cycle method (percent of the time braking is ON versus total time). Parameter B_90 sets the dynamic braking usage ratio. In the graph to the right, the example shows three uses of dynamic braking in a 100-second period. The inverter calculates the average percentage usage in that time (T%). The percentage of usage is proportional to the heat dissipated. If T% is greater than the B_90 parameter setting, the inverter enters the Trip Mode and turns OFF the frequency output.

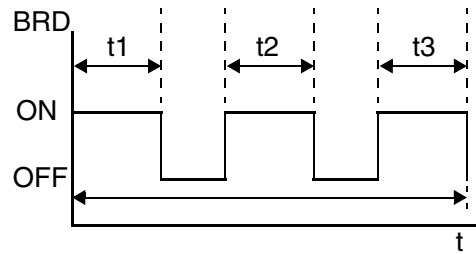

$$\boxed{\text{B } 90} \quad T\% = \frac{(t1 + t2 + t3)}{100 \text{ seconds}} \times 100$$

Please note the following:

- When B_90 is set for 0%, dynamic braking is not performed.
- When the T% value exceeds the limit set by B_90, dynamic braking ends.
- When mounting an external dynamic braking unit, set the usage ratio (B_90) to 0.0 and remove the external resistors.
- The cable from the external resistor to the inverter must not exceed 5 m (16 ft.) length.
- The individual wires from the resistor to the inverter must not be bundled together.

SJ100 Dynamic Braking Selection Tables

The SJ100 series inverter models have internal braking units. Additional stopping torque is available by adding external resistors. The required braking torque depends on your particular application. Other tables in this section will help you choose the proper resistor.

200V Class		Using Internal Resistor		Using External Resistor		Performance at Minimum Resistance			Min. Resistance at 100% Braking Duty Cycle (Ohms)
SJ100 Model Number	HP	Braking Unit	Braking Torque (%)	Resistance (Ohms)	Braking Torque	Min. Resistance (Ohms)	Braking Torque	Max. Braking Duty Cycle (%)	
002NFE/NFU	1/4	Built-in	50	180	150	100	200	10	150
004NFE/NFU	1/2	Built-in	50	180	150	100	200	10	150
005NFE	3/4	Built-in	50	180	150	100	200	10	150
007NFE/NFU	1	Built-in	50	100	150	35	200	10	150
011NFE	1.5	Built-in	50	50	150	35	200	10	150
015NFE/NFU	2	Built-in	50	50	150	35	200	10	100
022NFE/NFU	3	Built-in	20	50	100	35	150	10	100
037LFU	5	Built-in	20	35	100	35	100	10	100
055LFU	7.5	Built-in	20	17	80	17	80	10	50
075LFU	10	Built-in	20	17	80	17	80	10	50

400V Class		Using Internal Resistor		Using External Resistor		Performance at Minimum Resistance			Min. Resistance at 100% Braking Duty Cycle (Ohms)
SJ100 Model Number	HP	Braking Unit	Braking Torque (%)	Resistance (Ohms)	Braking Torque	Min. Resistance (Ohms)	Braking Torque	Max. Braking Duty Cycle (%)	
004HFE/HFU	1/2	Built-in	50	180	150	180	150	10	500
007HFE/HFU	1	Built-in	50	180	150	180	150	10	300
015HFE/HFU	2	Built-in	50	180	150	180	150	10	300
022HFE/HFU	3	Built-in	20	100	100	100	100	10	300
030HFE	4	Built-in	20	100	100	100	100	10	200
040HFE/HFU	5	Built-in	20	100	100	100	100	10	200
055HFE/HFU	7.5	Built-in	20	70	80	70	80	10	200
075HFE/HFU	10	Built-in	20	70	80	70	80	10	150

Selecting Braking Resistors for Internal Braking Units

You can add one or more resistors to your inverter configuration to increase braking torque performance. The tables below lists the resistor types for inverter models with internal braking units. Tables for inverters with external braking units are on the next two pages.

- Total Ohms – lists the resistance value of the resistor or, if using multiple resistors, their combined resistance
- Total Watts – lists the power dissipation of the resistor or, if using multiple resistors, their combined power dissipation
- Maximum Duty Cycle – the maximum allowable percentage of braking time over any 100-second interval to avoid overheating the resistor(s)
- Maximum Braking Torque – the maximum braking torque that the inverter / resistor combination can deliver

The table below lists 200V-class inverter models with built-in braking units. Depending on the desired braking torque or on the inverter model, the resistor selection specifies multiple resistors in a parallel or series combination. The example diagram shows a parallel configuration. Please refer to the braking resistor documentation for detailed wiring diagrams.

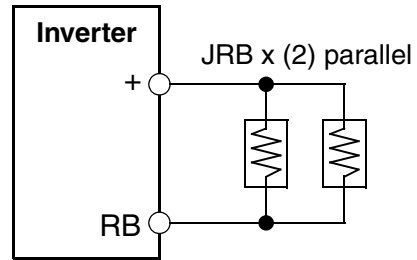

200V Class		Dynamic Braking Resistor Selection											
		JRB Series				SRB/NSRB Series				HRB Series			
SJ100 Model Number	HP	Type & (Qty)	Total Ohms	Total Watts	Max. Duty Cycle (%)	Type & (Qty)	Total Ohms	Total Watts	Max. Duty Cycle (%)	Type & (Qty)	Total Ohms	Total Watts	Max. Duty Cycle (%)
002NFE/NFU	1/4	120-1	180	120	5.0	200-1	180	200	10.0				
004NFE/NFU	1/2	120-1	180	120	5.0	200-1	180	200	10.0				
005NFE	3/4	120-1	180	120	5.0	200-1	180	200	10.0				
007NFE/NFU	1	120-2	100	120	2.5	200-2	100	200	7.5				
011NFE	1.5	120-2	100	120	2.5	200-2	100	200	7.5				
015NFE/NFU	2	120-3	50	120	1.5	300-1	50	300	7.5				
022NFE/NFU	3	120-3	50	120	1.5	300-1	50	300	7.5				
037LFU	5	120-4	35	120	1.0	400-1	35	400	7.5				
055LFU	7.5	120-4 x (2) in parallel	17.5	240	1.0	400-1	17.5	800	7.5	HRB3	17	1200	10.0
075LFU	10		17.5	240	1.0	x (2) in parallel	17.5	800	7.5	HRB3	17	1200	10.0

The table below lists 400V-class inverter models with built-in braking units. Depending on the desired braking torque or on the inverter model, the resistor selection specifies multiple resistors in a parallel or series combination. The example diagram shows a parallel configuration. Please refer to the braking resistor documentation for detailed wiring diagrams.

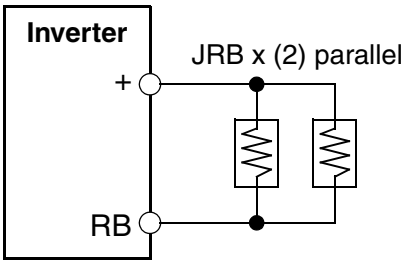

400V Class		Dynamic Braking Resistor Selection											
		JRB Series				SRB/NSRB Series				HRB Series			
SJ100 Model Number	HP	Type & (Qty)	Total Ohms	Total Watts	Max. Duty Cycle (%)	Type & (Qty)	Total Ohms	Total Watts	Max. Duty Cycle (%)	Type & (Qty)	Total Ohms	Total Watts	Max. Duty Cycle (%)
004HFE/HFU	1/2	120-1	180	120	2.0	200-1	180	200	4.0				
007HFE/HFU	1	120-1	180	120	2.0	200-1	180	200	4.0				
015HFE/HFU	2	120-1	180	120	2.0	200-1	180	200	4.0				
022HFE/HFU	3	120-2	100	120	1.5	200-2	100	200	3.0				
030HFE	4	120-2	100	120	1.5	200-2	100	200	3.0				
040HFE/HFU	5	120-2	100	120	1.5	200-2	100	200	3.0				
055HFE/HFU	7.5	120-4	70	240	1.0	400-1	70	800	7.5	RB2	70	1200	10.0
075HFE/HFU	10	x (2) in series	70	240	1.0	x (2) in series	70	800	7.5	x (2) in series	70	1200	10.0

Selecting Braking Resistors for External Braking Units

200V Class Inverters – The following tables specify the braking options for 200V class SJ100 inverters and the braking torque for each option. You can connect a single braking unit to the inverter, or two braking units for additional stopping torque.

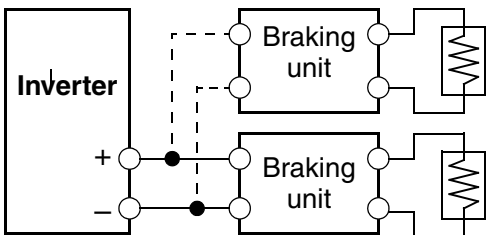

Use one BRD-E2 braking unit for the braking torque listed in the following table.

Note the column meanings in the tables:

- Column “A” = Average braking torque from 60 Hz to 3 Hz.
- Column “B” = Average braking torque from 120 Hz to 3 Hz.

SJ100 Inverter 200V Models			Braking Torque with BRD-E2 Braking Unit							
Model Number	HP	Braking torque without braking unit	Using built-in resistor only		External resistor added					
					HRB1		HRB2		HRB3	
			A	B	A	B	A	B	A	B
002NFE/NFU	1/4	50%	150%	120%						
004NFE/NFU	1/2	50%	150%	120%						
005NFE	3/4	50%	100%	80%	150%	120%				
007NFE/NFU	1	50%	100%	80%	150%	120%				
011NFE	1.5	50%	60%	60%	100%	80%				
015NFE/NFU	2	50%	50%	50%	100%	80%				
022NFE/NFU	3	20%	50%	50%	100%	80%				
037LFU	5	20%	40%	40%	60%	60%	100%	80%	150%	120%
055LFU	7.5	20%	30%	30%	50%	50%	80%	60%	100%	80%
075LFU	10	20%	20%	20%	40%	40%	60%	60%	80%	80%

Connect a second braking unit in parallel for additional braking torque listed in the following table.

SJ100 Inverter 200V Models			Braking Torque with TWO (2) BRD-E2 Braking Units							
Model Number	HP	Braking torque without braking unit	Using built-in resistor only		External resistor added					
					HRB1		HRB2		HRB3	
			A	B	A	B	A	B	A	B
002NFE/NFU	1/4	50%	150%	150%						
004NFE/NFU	1/2	50%	150%	150%						
005NFE	3/4	50%	150%	150%						
007NFE/NFU	1	50%	150%	120%						
011NFE	1.5	50%	100%	80%						
015NFE/NFU	2	50%	70%	70%	150%	120%				
022NFE/NFU	3	20%	70%	70%	150%	120%				
037LFU	5	20%	50%	50%	110%	90%				
055LFU	7.5	20%	30%	30%	80%	80%	90%	90%	100%	80%
075LFU	10	20%	30%	30%	60%	60%	80%	80%	100%	80%

400V Class Inverters –The following tables specify the braking options for 400V class SJ100 inverters and the braking torque for each option. You can connect a single braking unit to the inverter, or two braking units for additional braking torque.

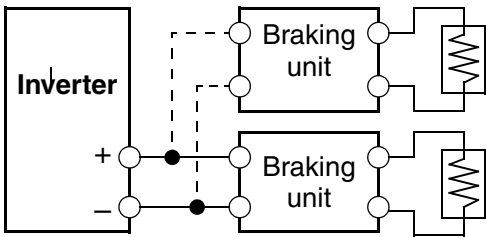

Use one BRD-E2 braking unit for the braking torque listed in the following table.

SJ100 Inverter 400V Models			Braking Torque with BRD-EZ2 Braking Unit							
Model Number	HP	Braking torque without braking unit	Using built-in resistor only		External resistor added					
					HRB1		HRB2		HRB3	
			A	B	A	B	A	B	A	B
004HFE/HFU	1/2	50%	150%	120%						
007HFE/HFU	1	50%	100%	80%	150%	120%				
015HFE/HFU	2	50%	60%	60%	100%	80%	120%	100%	150%	120%
022HFE/HFU	3	20%	50%	50%	100%	80%	120%	100%	150%	120%
030HFE	4	20%	40%	40%	80%	60%	100%	80%	150%	120%
040HFE/HFU	5	20%	40%	40%	60%	60%	80%	60%	150%	120%
055HFE/HFU	7.5	20%	30%	30%	50%	50%	80%	60%	100%	80%
075HFE/HFU	10	20%	20%	20%	40%	40%	60%	40%	80%	80%

Connect a second braking unit in parallel for additional braking torque listed in the following table.

SJ100 Inverter 400V Models			Braking Torque with TWO (2) BRD-EZ2 Braking Units							
Model Number	HP	Braking torque without braking unit	Using built-in resistor only		External resistor added					
					HRB1		HRB2		HRB3	
			A	B	A	B	A	B	A	B
004HFE/HFU	1/2	50%	150%	120%						
007HFE/HFU	1	50%	150%	120%						
015HFE/HFU	2	50%	100%	80%						
022HFE/HFU	3	20%	70%	70%	150%	120%				
030HFE	4	20%	50%	50%	110%	90%				
040HFE/HFU	5	20%	50%	50%	110%	90%				
055HFE/HFU	7.5	20%	30%	30%	80%	80%	90%	90%	100%	100%
075HFE/HFU	10	20%	30%	30%	60%	60%	80%	80%	100%	100%

Troubleshooting and Maintenance



6

In This Chapter....	page
— Troubleshooting	2
— Monitoring Trip Events, History, & Conditions .	5
— Restoring Factory Default Settings	8
— Maintenance and Inspection	9
— Warranty	16

Troubleshooting

Safety Messages

Please read the following safety messages before troubleshooting or performing maintenance on the inverter and motor system.



WARNING: Wait at least five (5) minutes after turning OFF the input power supply before performing maintenance or an inspection. Otherwise, there is the danger of electric shock.



WARNING: Make sure that only qualified personnel will perform maintenance, inspection, and part replacement. Before starting to work, remove any metallic objects from your person (wristwatch, bracelet, etc.). Be sure to use tools with insulated handles. Otherwise, there is a danger of electric shock and/or injury to personnel.



WARNING: Never remove connectors by pulling on its wire leads (wires for cooling fan and logic P.C.board). Otherwise, there is a danger of fire due to wire breakage and/or injury to personnel.

General Precautions and Notes

- Always keep the unit clean so that dust or other foreign matter does not enter the inverter.
- Take special care in regard to breaking wires or making connection mistakes.
- Firmly connect terminals and connectors.
- Keep electronic equipment away from moisture and oil. Dust, steel filings and other foreign matter can damage insulation, causing unexpected accidents, so take special care.

Inspection Items

This chapter provides instructions or checklists for these inspection items:

- Daily inspection
- Periodic inspection (approximately once a year)
- Insulation resistance test

Troubleshooting Tips

The table below lists typical symptoms and the corresponding solution(s).

Symptom/condition		Probable Cause	Solution
The motor will not run.	The inverter outputs [U], [V], [W] are not supplying voltage.	<ul style="list-style-type: none"> Is the frequency command source A_01 parameter setting correct? Is the Run command source A_02 parameter setting correct? 	<ul style="list-style-type: none"> Make sure the parameter setting A_01 is correct. Make sure the parameter setting A_02 is correct.
		<ul style="list-style-type: none"> Is power being supplied to terminals [L1], [L2], and [L3/N]? If so, the POWER lamp should be ON. 	<ul style="list-style-type: none"> Check terminals [L1], [L2], and [L3/N], then [U/T1], [V/T2], and [W/T3]. Turn ON the power supply or check fuses.
		<ul style="list-style-type: none"> Is there an error code EXX displayed? 	<ul style="list-style-type: none"> Press the Func. key and determine the error type. Eliminate the error cause, then clear the error (Reset).
		<ul style="list-style-type: none"> Are the signals to the intelligent input terminals correct? Is the Run Command active? Is the [FW] terminal (or [RV]) connected to [P24] (via switch, etc.) 	<ul style="list-style-type: none"> Verify the terminal functions for C_01 – C_06 are correct. Turn ON Run Command enable. Supply 24V to {FW} or [RV] terminal, if configured.
		<ul style="list-style-type: none"> Has the frequency setting for F_01 been set greater than zero? Are the control circuit terminals [H], [O], and [L] connected to the potentiometer? 	<ul style="list-style-type: none"> Set the parameter for F_01 to a safe, non-zero value. If the potentiometer is the frequency setting source, verify voltage at [O] > 0V.
	<ul style="list-style-type: none"> Is the RS (reset) function or FRS (free-run stop) function ON? 	<ul style="list-style-type: none"> Turn OFF the command(s). 	
	Inverter outputs [U], [V], [W] are supplying voltage.	<ul style="list-style-type: none"> Is the motor load too heavy? 	<ul style="list-style-type: none"> Reduce load, and test the motor independently.
	The optional remote operator is used (SRW).	<ul style="list-style-type: none"> Are the operational settings between the remote operator and the inverter unit correct? 	<ul style="list-style-type: none"> Check the operator type setting.
The direction of the motor is reversed.		<ul style="list-style-type: none"> Are the connections of output terminals [U/T1], [V/T2], and [W/T3] correct? Is the phase sequence of the motor forward or reverse with respect to [U/T1], [V/T2], and [W/T3]? 	<ul style="list-style-type: none"> Make connections according to the phase sequence of the motor. In general: FWD = U-V-W, and REV=U-W-V.
		<ul style="list-style-type: none"> Are the control terminals [FW] and [RV] wired correctly? Is parameter F_04 properly set? 	<ul style="list-style-type: none"> Use terminal [FW] for forward, and [RV] for reverse. Set motor direction in F_04.

Symptom/condition		Probable Cause	Solution
The motor speed will not reach the target frequency (desired speed).		<ul style="list-style-type: none"> • If using the analog input, is the current or voltage at [O] or [OI]? 	<ul style="list-style-type: none"> • Check the wiring. • Check the potentiometer or signal generating device.
		<ul style="list-style-type: none"> • Is the load too heavy? 	<ul style="list-style-type: none"> • Reduce the load. • Heavy loads activate the overload restriction feature (reduces output as needed).
		<ul style="list-style-type: none"> • Is the inverter internally limiting the output frequency? 	<ul style="list-style-type: none"> • Check max frequency setting (A_04) • Check frequency upper limit setting (A_61)
The rotation is unstable.		<ul style="list-style-type: none"> • Is the load fluctuation too great? • Is the supply voltage unstable? • Is the problem occurring at a particular frequency? 	<ul style="list-style-type: none"> • Increase the motor capacity (both inverter and motor). • Fix power supply problem. • Change the output frequency slightly, or use the jump frequency setting to skip the problem frequency.
The RPM of the motor does not match the inverter output frequency setting.		<ul style="list-style-type: none"> • Is the maximum frequency setting A_04 correct? • Does the monitor function D_01 display the expected output frequency? 	<ul style="list-style-type: none"> • Verify the V/f settings match motor specifications. • Make sure all scaling (such as A_11 to A_14) is properly set.
Inverter data is not correct.	No downloads have occurred.	<ul style="list-style-type: none"> • Was power turned OFF after a parameter edit but before pressing the Store key? 	<ul style="list-style-type: none"> • Edit the data and press the Store key once.
		<ul style="list-style-type: none"> • Edits to data are permanently stored at power down. Was the time from power OFF to power ON less than six seconds? 	<ul style="list-style-type: none"> • Wait six seconds or more before turning power OFF after editing data.
	A download to the inverter was attempted.	<ul style="list-style-type: none"> • Was the power turned OFF within six seconds after the display changed from REMT to INV? 	<ul style="list-style-type: none"> • Copy the data to the inverter again, and keep power ON for six seconds or more after copying.
A parameter will not change after an edit (reverts to old setting).	True for certain parameters	<ul style="list-style-type: none"> • Is the inverter in Run Mode? Some parameters cannot be edited during Run Mode. 	<ul style="list-style-type: none"> • Put inverter in Stop Mode (press the Stop/reset key). Then edit the parameter.
	True for all parameters	<ul style="list-style-type: none"> • If you're using the [SFT] intelligent input (software lock function)—is the [SFT] input ON? 	<ul style="list-style-type: none"> • Change the state of the SFT input, and check the B_31 parameter (SFT mode).

Monitoring Trip Events, History, & Conditions

Fault Detection and Clearing

The microprocessor in the inverter detects a variety of fault conditions and captures the event, recording it in a history table. The inverter output turns OFF, or “trips” similar to the way a circuit breaker trips due to an over-current condition. Most faults occur when the motor is running (refer to the diagram to the right). However, the inverter could have an internal fault and trip in Stop Mode. In either case, you can clear the fault by pressing the Stop/Reset key. Additionally, you can clear the inverter’s cumulative trip history by performing the procedure [“Restoring Factory Default Settings” on page 6-8](#) (setting B_84=00 will clear the trip history but leave inverter settings intact).

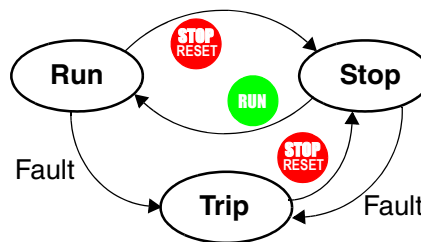

Error Codes

An error code will appear on the display automatically when a fault causes the inverter to trip. The following table lists the cause associated with the error.

Error Code	Name	Cause(s)
E01	Over current event while at constant speed	The inverter output was short-circuited, or the motor shaft is locked or has a heavy load. These conditions cause excessive current for the inverter, so the inverter output is turned OFF.
E02	Over current event during deceleration	
E03	Over current event during acceleration	
E04	Over current event during other conditions	
E05	Overload protection	When a motor overload is detected by the electronic thermal function, the inverter trips and turns OFF its output.
E06	Braking resistor overload	When the regenerative braking resistor exceeds the usage time allowance or usage ratio, the inverter trips and turns OFF its output to the motor.
E07	Over voltage protection	When the DC bus voltage exceeds a threshold, due to regenerative energy from the motor.
E08	EEPROM error	When the built-in EEPROM memory has problems due to noise or excessive temperature, the inverter trips and turns OFF its output to the motor.
E09	Under-voltage error	A decrease of internal DC bus voltage below a threshold results in a control circuit fault. This condition can also generate excessive motor heat or cause low torque. The inverter trips and turns OFF its output.

Error Code	Name	Cause(s)
E10	CT (current transformer) error	If a strong source of electrical interference is close to the inverter or a fault occurs in a built-in CT (current transformer), the inverter trips and turns its output OFF.
E11 E22	CPU error	A malfunction in the built-in CPU has occurred, so the inverter trips and turns OFF its output to the motor.
E12	External trip	A signal on an intelligent input terminal configured as EXT has occurred. The inverter trips and turns OFF the output to the motor.
E13	USP	When the Unattended Start Protection (USP) is enabled, an error occurred when power is applied while a Run signal is present. The inverter trips and does not go into Run Mode until the error is cleared.
E14	Ground fault	The inverter is protected by the detection of ground faults between the inverter output and the motor upon during powerup tests. This feature protects the inverter, and does not protect humans.
E15	Input over-voltage	When the input voltage is higher than the specified value, it is detected 100 seconds after powerup and the inverter trips and turns OFF its output.
E21	Inverter thermal trip	When the inverter internal temperature is above the threshold, the thermal sensor in the inverter module detects the excessive temperature of the power devices and trips, turning the inverter output OFF.
E35	Thermistor	Due to low input voltage, the inverter turns its output OFF and tries to restart. If it fails to restart, then the alarm trips to record the under-voltage error event.
- - - U	Under-voltage (brown-out) with output shutoff	Low input voltage caused the inverter to turn OFF the motor output and try to restart. If unsuccessful, a trip occurs.



NOTE: If an EEPROM error (E08) occurs, be sure to confirm the parameter data values are still correct. If the power is turned OFF while the [RS] (Reset) intelligent input terminal is ON, an EEPROM error will occur when power is restored.

Trip History and Inverter Status





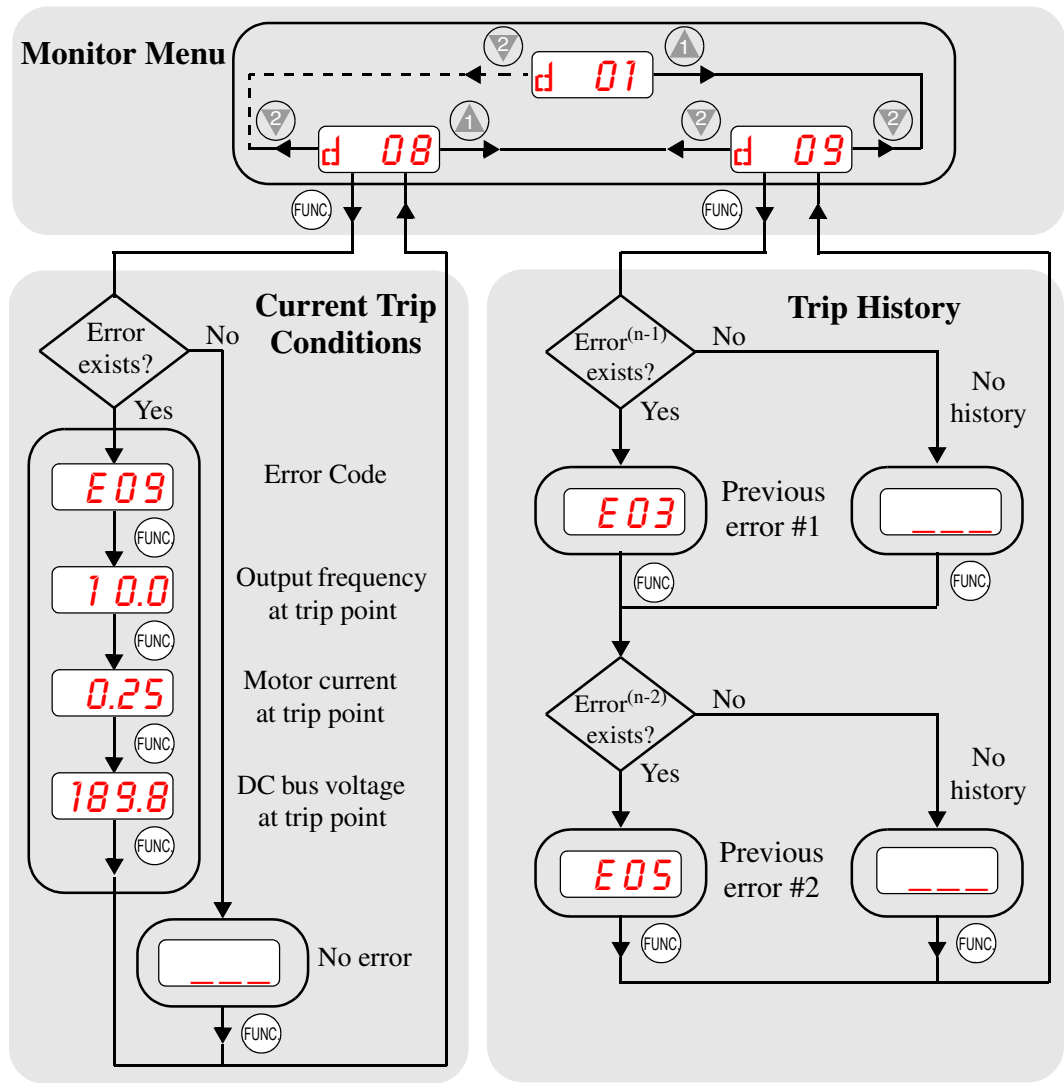





We recommend that you first find the cause of the fault before clearing it. When a fault occurs, the inverter stores important performance data at the moment of the fault. To access the data, use the monitor functions (D_xx) and select D_08 for details about the present fault (Eⁿ), or the error code for the past two trip events (Eⁿ⁻¹ and Eⁿ⁻²) using the D_09 Trip History function.

The following Monitor Menu map shows how to access the error codes. When fault(s) exist, you can review their details by first selecting the proper function: D_08 displays current trip data, and D_09 displays trip history.

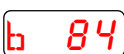

Restoring Factory Default Settings

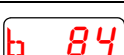
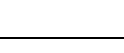
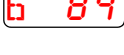
You can restore all inverter parameters to the original factory (default) settings for the intended country of use. After initializing the inverter, use the powerup test in Chapter 2 to get the motor running again. To initialize the inverter, follow the steps below.

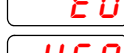
No.	Action	Display	Func./Parameter
1	Use the FUNC , ▲ , and ▼ keys to navigate to the “B” Group.		“B” Group selected
2	Press the FUNC key.		First “B” parameter selected
3	Press and hold the ▲ key until ->		Country code for initialization selected
4	Press the FUNC key.		00 = Japan, 01 = Europe, 02 = U.S.
5	Confirm the country code is correct. Do not change it unless you are absolutely sure the power input voltage range and frequency match the country code setting. To change the country code, press ▲ or ▼ to set, STR to store.		
6	Press the FUNC key.		Country code for initialization selected
7	Press the ▼ key.		Initialization function selected
8	Press the FUNC key.		00 = initialization disabled, clear trip history only
9	Press the ▲ key.		01 = initialization enabled
10	Press the STR key.		Initialization now enabled to restore all defaults
11	Press and hold the FUNC , ▲ , and ▼ keys. Do not release yet.		First part of special key sequence
12	Holding the keys above, press and hold the STOP RESET (STOP) key for 3 sec.		Final part of special key sequence
13	Release only the STOP RESET (STOP) key, and wait for the display d 01 to appear and begin blinking.		Initialization begins when display starts blinking
14	Now release the FUNC , ▲ , and ▼ keys only after the d 01 display function begins blinking.	 	Default parameter country code shown during initialization process (left-most char displays alternating pattern)
15	Initialization is complete.		Function code for output frequency monitor shown



NOTE: Initialization cannot be performed with a remote operator panel. Disconnect the device and use the inverter’s front panel keypad.

Maintenance and Inspection

Monthly and Yearly Inspection Chart

Item Inspected		Check for...	Inspection Cycle		Inspection Method	Criteria
			Month	Year		
Overall	Ambient environment	Extreme temperatures & humidity	✓		Thermometer, hygrometer	Ambient temperature between -10 to 40°C, non-condensing
	Major devices	Abnormal noise & vib.	✓		Visual and aural	Stable environment for electronic controls
	Power supply voltage	Voltage tolerance	✓		Digital volt meter, measure between inverter terminals [L1], [L2], [L3]	200V class: 200 to 240V 50/60 Hz 400V class: 380 to 460V 50/60 Hz
Main circuit	Ground Insulation	Adequate resistance		✓	Digital volt meter, GND to terminals	5 Meg. Ohms or greater
	Mounting	No loose screws		✓	Torque wrench	M3: 0.5 – 0.6 Nm M4: 0.98 – 1.3 Nm M5: 1.5 – 2.0 Nm
	Components	Overheating		✓	Thermal trip events	No trip events
	Housing	Dirt, dust		✓	Visual	Vacuum dust and dirt
	Terminal block	Secure connections		✓	Visual	No abnormalities
	Smoothing capacitor	Leaking, swelling	✓		Visual	No abnormalities
	Relay(s)	Chattering		✓	Aural	Single click when switching ON or OFF
	Resistors	Cracks or discoloring		✓	Visual	Use Ohm meter to check braking resistors
	Cooling fan	Noise	✓		Power down, manually rotate	Rotation must be smooth
	Dust	✓		Visual	Vacuum to clean	
Control circuit	Overall	No odor, discoloring, corrosion		✓	Visual	No abnormalities
	Capacitor	No leaks or deformation	✓		Visual	Undistorted appearance
Display	LEDs	Legibility	✓		Visual	All LED segments work

Note 1: The life of a capacitor is affected by the ambient temperature. See [“Capacitor Life Curve” on page 6-11](#).

Note 2: The inverter must be cleaned periodically. If dust accumulates on the fan and heat sink, it can cause overheating of the inverter.

Megger Test

The *megger* is a piece of test equipment that uses a high voltage to determine if an insulation degradation has occurred. For inverters, it is important that the power terminals be isolated from the Earth GND terminal via the proper amount of insulation.

The circuit diagram below shows the inverter wiring for performing the megger test. Just follow the steps to perform the test:

1. Remove power from the inverter and wait at least 5 minutes before proceeding.
2. Open the front housing panel to access the power wiring.
3. Remove all wires to terminals [R, S, T, RB, +1, +, -, U, V, and W]. Most importantly, the input power and motor wires will be disconnected from the inverter.
4. Use a bare wire and short terminals [R, S, T, RB, +1, +, -, U, V, and W] together as shown in the diagram.
5. Connect the megger to the inverter Earth GND and to the shorted power terminals as shown. Then perform the megger test at 500 VDC and verify 5M Ω or greater resistance.

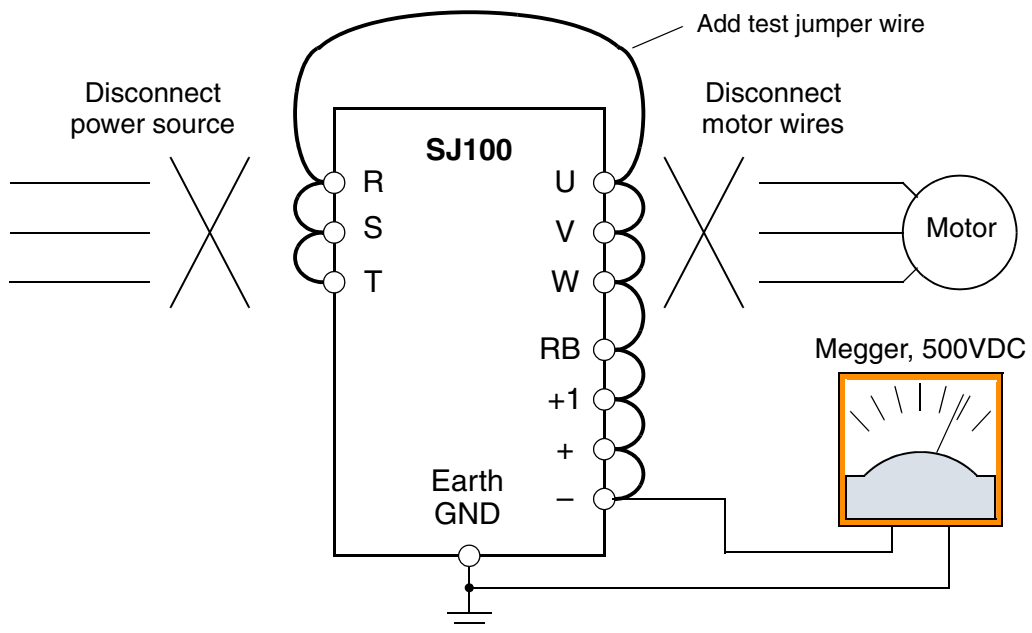

6. After completing the test, disconnect the megger from the inverter.
7. Reconnect the original wires to terminals [R, S, T, RB, +1, +, -, U, V, and W].



CAUTION: Do not connect the megger to any control circuit terminals such as intelligent I/O, analog terminals, etc. Doing so could cause damage to the inverter.



CAUTION: Never test the withstand voltage (HIPOT) on the inverter. The inverter has a surge protector between the main circuit terminals above and the chassis ground.

Spare parts

We recommend that you stock spare parts to reduce down time, including these parts:

Part description	Symbol	Quantity		Notes
		Used	Spare	
Cooling fan	FAN	1	1	022NF, 030HF, 037LF, 015HF to 075HF
Case	CV	1	1	<ul style="list-style-type: none"> • Front case • Key cover • Case • Bottom cover

Capacitor Life Curve

The DC bus inside the inverter uses a large capacitor as shown in the diagram below. The capacitor handles high voltage and current as it smooths the power for use by the inverter. So, any degradation of the capacitor will affect the performance of the inverter.

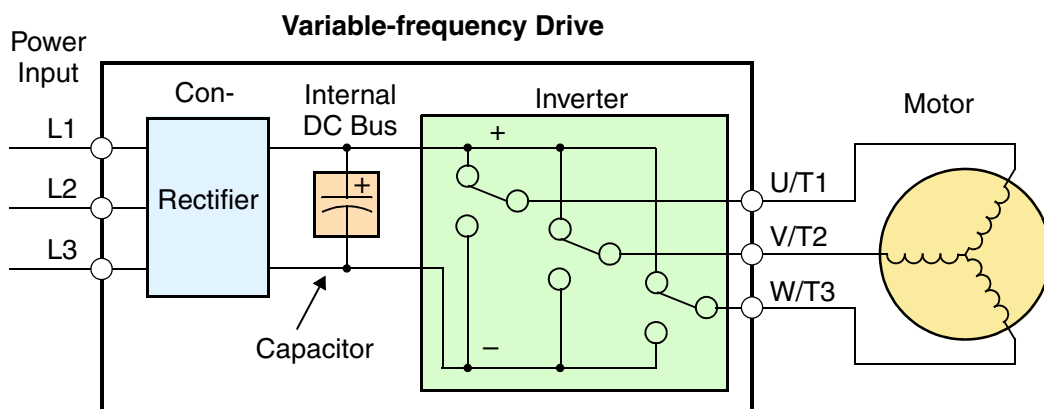

Capacitor life is reduced in higher ambient temperatures, as the graph below demonstrates. Be sure to keep the ambient temperature at acceptable levels, and perform maintenance inspections on the fan, heat sink, and other components. If the inverter is installed on a cabinet, the ambient temperature is the temperature inside the cabinet.

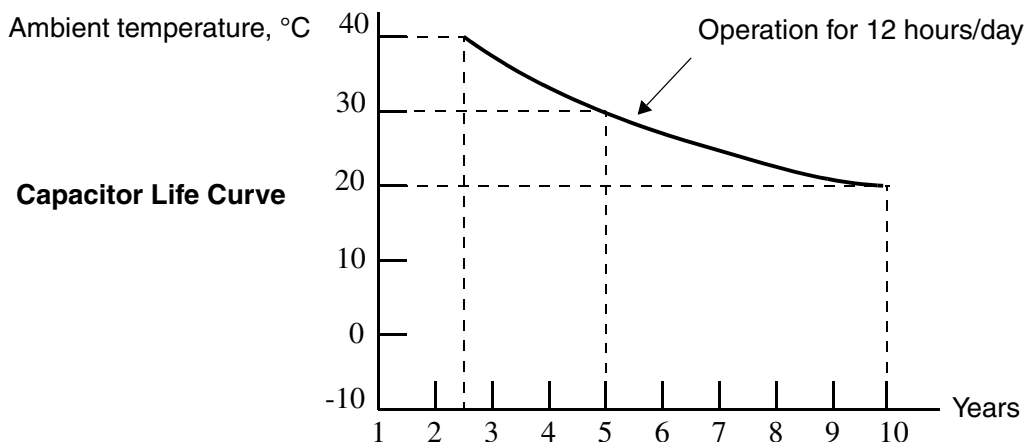

General Inverter Electrical Measurements

The following table specifies how to measure key system electrical parameters. The diagrams on the next page show inverter-motor systems and the location of measurement points for these parameters.

Parameter	Circuit location of measurement	Measuring instrument	Notes	Reference Value
Supply voltage E_1	E_R – across L1 and L2 E_S – across L2 and L3 E_T – across L3 and L1	Moving-coil type voltmeter or rectifier type voltmeter	Fundamental wave effective value	Commercial supply voltage (200V class) 200–240V, 50/60 Hz 400V class 380–460V, 50/60 Hz
Supply current I_1	I_r – L1, I_s – L2, I_t – L3		Total effective value	—
Supply power W_1	W_{11} – across L1 and L2 W_{12} – across L2 and L3		Total effective value	—
Supply power factor Pf_1	$Pf_1 = \frac{W_1}{\sqrt{3} \times E_1 \times I_1} \times 100\%$			—
Output voltage E_0	E_U – across U and V E_V – across V and W E_W – across W and U	Rectifier type voltmeter	Total effective value	—
Output current I_0	I_U – U I_V – V I_W – W	Moving-coil ammeter	Total effective value	—
Output power W_0	W_{01} – across U and V W_{02} – across V and W	Electronic type wattmeter	Total effective value	—
Output power factor Pf_0	Calculate the output power factor from the output voltage E, output current I, and output power W. $Pf_0 = \frac{W_0}{\sqrt{3} \times E_0 \times I_0} \times 100\%$			—

- Note 1:** Use a meter indicating a fundamental wave effective value for voltage, and meters indicating total effective values for current and power.
- Note 2:** The inverter output has a distorted waveform, and low frequencies may cause erroneous readings. However, the measuring instruments and methods listed above provide comparably accurate results.
- Note 3:** A general-purpose digital volt meter (DVM) is not usually suitable to measure a distorted waveform (not pure sinusoid).

The figures below show measurement locations for voltage, current, and power measurements listed in the table on the previous page. The voltage to be measured is the fundamental wave effective voltage. The power to be measured is the total effective power.

Single-phase Measurement Diagram

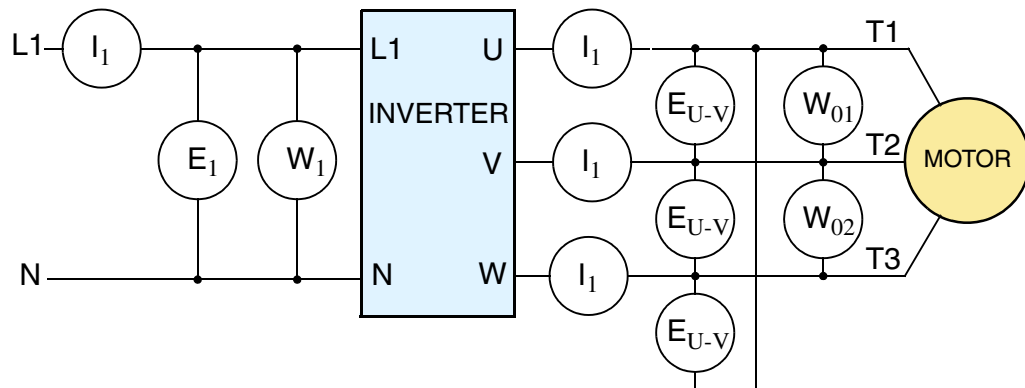

Three-phase Measurement Diagram

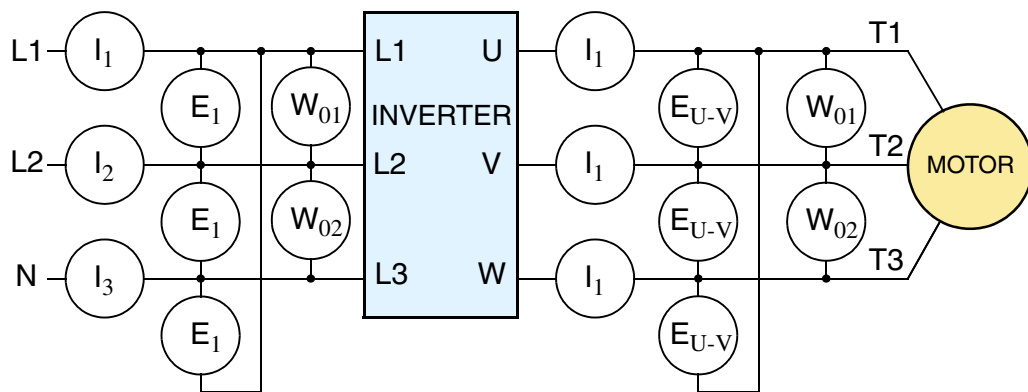

Inverter Output Voltage Measurement Techniques

Taking voltage measurements around drives equipment requires the right equipment and a safe approach. You are working with high voltages and high-frequency switching waveforms that are not pure sinusoids. Digital voltmeters will not usually produce reliable readings for these waveforms. And, it is usually risky to connect high voltage signals to oscilloscopes. The inverter output semiconductors have some leakage, and no-load measurements produce misleading results. So, we highly recommend using the following circuits to measure voltage for performing the equipment inspections.

Voltage measurement *with load*

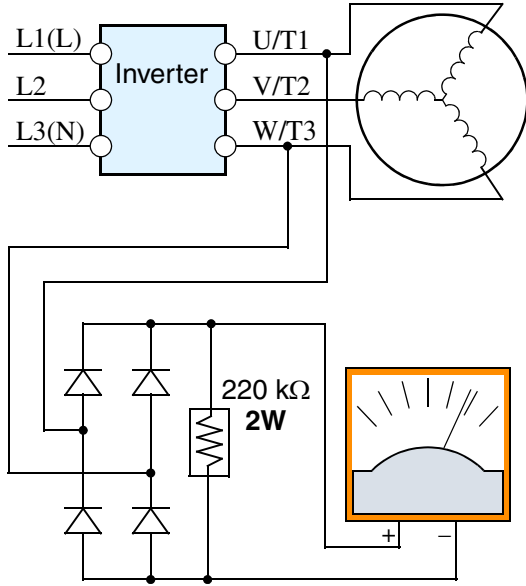

V Class	Diode Bridge	Voltmeter
200V Class	600V 0.01A min.	300V range
400V Class	100V 0.1A min.	600V range

Voltage measurement *without load*

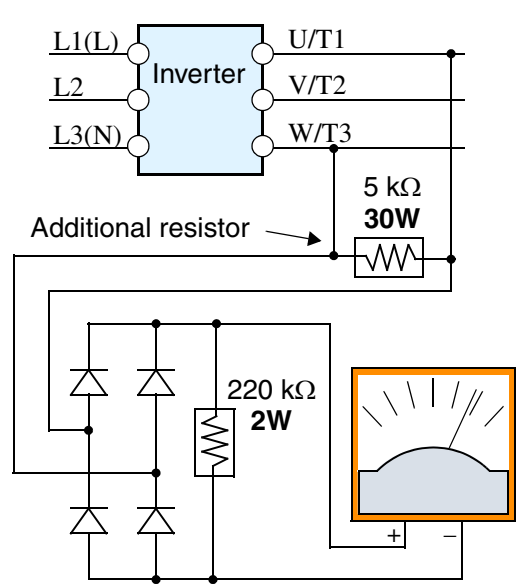

V Class	Diode Bridge	Voltmeter
200V Class	600V 0.01A min.	300V range
400V Class	100V 0.1A min.	600V range



HIGH VOLTAGE: Be careful not to touch wiring or connector terminals when working with the inverters and taking measurements. Be sure to place the measurement circuitry components above in an insulated housing before using them.

IGBT Test Method

The following procedure will check the inverter transistors (IGBTs) and diodes:

1. Disconnect input power to terminals [R, S, and T] and motor terminals [U, V, and W].
2. Disconnect any wires from terminals [+] and [RB] for regenerative braking.
3. Use a Digital Volt Meter (DVM) and set it for 1Ω resistance range. You can check the status of the charging state of terminals [R, S, T, U, V, W, RB, +, and -] of the inverter and the probe of the DVM by measuring the charging state.

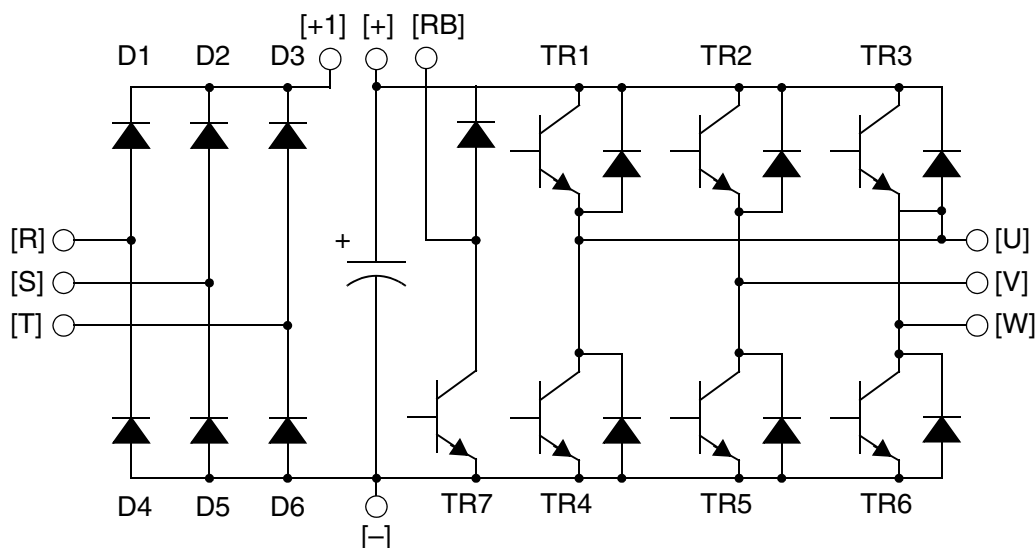

Table Legend – Almost infinite resistance: $\cong \infty \Omega$ Almost zero resistance: $\cong 0 \Omega$

Part	DVM		Measured Value	Part	DVM		Measured Value	Part	DVM		Measured Value
	+	-			+	-			+	-	
D1	[R]	+1	$\cong \infty \Omega$	D5	[S]	[N]	$\cong 0 \Omega$	TR4	[U]	[-]	$\cong 0 \Omega$
	+1	[R]	$\cong 0 \Omega$		[N]	[S]	$\cong \infty \Omega$		[-]	[U]	$\cong \infty \Omega$
D2	[S]	+1	$\cong \infty \Omega$	D6	[T]	[N]	$\cong 0 \Omega$	TR5	[V]	[-]	$\cong 0 \Omega$
	+1	[S]	$\cong 0 \Omega$		[N]	[T]	$\cong \infty \Omega$		[-]	[V]	$\cong \infty \Omega$
D3	[T]	+1	$\cong \infty \Omega$	TR1	[U]	[+]	$\cong \infty \Omega$	TR6	[W]	[-]	$\cong 0 \Omega$
	+1	[T]	$\cong 0 \Omega$		[+]	[U]	$\cong 0 \Omega$		[-]	[W]	$\cong \infty \Omega$
D4	[R]	[N]	$\cong 0 \Omega$	TR2	[V]	[+]	$\cong \infty \Omega$	TR7	[RB]	[+]	$\cong 0 \Omega$
	[N]	[R]	$\cong \infty \Omega$		[+]	[V]	$\cong 0 \Omega$		[+]	[RB]	$\cong \infty \Omega$
				TR3	[W]	[+]	$\cong \infty \Omega$	[RB]	[-]	$\cong 0 \Omega$	
					[+]	[W]	$\cong 0 \Omega$	[-]	[RB]	$\cong 0 \Omega$	



NOTE: The resistance values for the diodes or the transistors will not be exactly the same, but they will be close. If you find a significance difference, a problem may exist.



NOTE: Before measuring the voltage between [+] and [-] with the DC current range, confirm that the smoothing capacitor is discharged fully, then execute the tests.

Warranty

Warranty Terms

The warranty period under normal installation and handling conditions shall be two (2) years from the date of manufacture (“DATE” on product nameplate), or one (1) year from the date of installation, whichever occurs first. The warranty shall cover the repair or replacement, at Hitachi's sole discretion, of ONLY the inverter that was installed.

1. Service in the following cases, even within the warranty period, shall be charged to the purchaser:
 - a. Malfunction or damage caused by mis-operation or modification or improper repair
 - b. Malfunction or damage caused by a drop after purchase and transportation
 - c. Malfunction or damage caused by fire, earthquake, flood, lightning, abnormal input voltage, contamination, or other natural disasters
2. When service is required for the product at your work site, all expenses associated with field repair shall be charged to the purchaser.
3. Always keep this manual handy; please do not lose it. Please contact your Hitachi distributor to purchase replacement or additional manuals.

Glossary and Bibliography

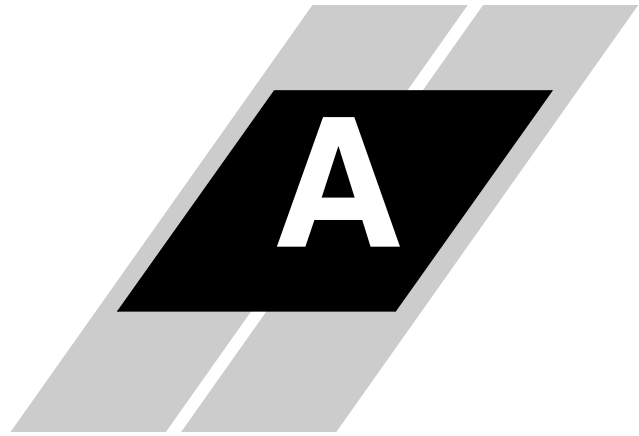

In This Appendix....	page
— Glossary	2
— Bibliography	8

Glossary

- Ambient Temperature** The air temperature in the chamber containing a powered electronic unit. A unit's heat sinks rely on a lower ambient temperature in order to dissipate heat away from sensitive electronics.
- Arrival Frequency** The arrival frequency refers to the set output frequency of the inverter for the constant speed setting. The arrival frequency feature turns on an output when the inverter reaches the set constant speed. The inverter has various arrival frequencies and pulsed or latched logic options.
- Auto-tuning** The ability of a controller to execute a procedure that interacts with a load to determine the proper coefficients to use in the control algorithm. Auto-tuning is a common feature of process controllers with PID loops. Hitachi inverters feature auto tuning to determine motor parameters for optimal commutation. Auto-tuning is available as a special command from a digital operator panel. See also *Digital Operator Panel*.
- Base Frequency** The power input frequency for which an AC induction motor is designed to operate. Most motors will specify a 50 to 60 Hz value. The Hitachi inverters have a programmable base frequency, so you must ensure that parameter matches the attached motor. The term *base frequency* helps differentiate it from the carrier frequency. See also *Carrier Frequency* and *Frequency Setting*.
- Braking Resistor** An energy-absorbing resistor that dissipates energy from a decelerating load. Load inertia causes the motor to act as a generator during deceleration. See also *Four-quadrant Operation* and *Dynamic Braking*.
- Break-away Torque** The torque a motor must produce to overcome the static friction of a load, in order to start the load moving.
- Carrier Frequency** The frequency of the constant, periodic, switching waveform that the inverter modulates to generate the AC output to the motor. See also *PWM*.
- CE** A regulatory agency for governing the performance of electronic products in Europe. Drive installations designed to have CE approval must have particular filter(s) installed in the application.
- Choke** An inductor that is tuned to react at radio frequencies is called a "choke," since it attenuates (chokes) frequencies above a particular threshold. Tuning is often accomplished by using a movable magnetic core. In variable-frequency drive systems, a choke positioned around high-current wiring can help attenuate harmful harmonics and protect equipment. See also *Harmonics*.

DC Braking	The inverter DC braking feature stops the AC commutation to the motor, and sends a DC current through the motor windings in order to stop the motor. Also called “DC injection braking,” it has little effect at high speed, and is used as the motor is nearing a stop.
Deadband	In a control system, the range of input change for which there is no perceptible change in the output. In PID loops, the error term may have a dead band associated with it. Deadband may or may not be desirable; it depends on the needs of the application.
Digital Operator Panel	For Hitachi inverters, “digital operator panel” (DOP) refers first to the operator keypad on the front panel of the inverter. It also includes hand-held remote keypads, which connect to the inverter via a cable. Finally, the DOP Professional is a PC-based software simulation of the keypad devices.
Diode	A semiconductor device that has a voltage-current characteristic that allows current to flow only in one direction, with negligible leakage current in the reverse direction. See also <i>Rectifier</i> .
Duty Cycle	1. The percent of time a square wave of fixed frequency is ON (high) versus OFF (low). 2. The ratio of operating time of a motor, braking resistor, etc. to its resting time. This parameter usually is specified in association with the allowable thermal rise for the device.
Dynamic Braking	The inverter dynamic braking feature shunts the motor-generated EMF energy into a special braking resistor. The added dissipation (braking torque) is effective at higher speeds, having a reduced effect as the motor nears a stop.
Error	In process control, the error is the difference between the desired value or setpoint (SP) and the actual value of a the process variable (PV). See also <i>Process Variable</i> and <i>PID Loop</i> .
EMI	Electromagnetic Interference - In motor/drive systems, the switching of high currents and voltages creates the possibility of generating radiated electrical noise that may interfere with the operation of nearby sensitive electrical instruments or devices. Certain aspects of an installation, such as long motor lead wire lengths, tend to increase the chance of EMI. Hitachi provides accessory filter components you can install to decrease the level of EMI.
Four-quadrant operation	Referring to a graph of torque versus direction, a four-quadrant drive can turn the motor either forward or reverse, as well as decelerate in either direction (see also <i>reverse torque</i>). A load that has a relatively high inertia and must move in both directions and change directions rapidly requires four-quadrant capability from its drive.
Free-run Stop	A method of stopping a motor, caused when the inverter simply turns OFF its motor output connections. This may allow the motor and load to coast to a stop, or a mechanical brake may intervene and shorten the deceleration time.

- Frequency Setting** While frequency has a broad meaning in electronics, it typically refers to motor speed for variable-frequency drives (inverters). This is because the output frequency of the inverter is variable, and is proportional to the attained motor speed. For example, a motor with a base frequency of 60 Hz can be speed controlled with an inverter output varying from 0 to 60 Hz. See also *Base Frequency*, *Carrier Frequency*, and *Slip*.
- Harmonics** A *harmonic* is a whole number multiple of a base or fundamental frequency. The square waves used in inverters produce high-frequency harmonics, even though the main goal is to produce lower-frequency sine waves. These harmonics can be harmful to electronics (including motor windings) and cause radiated energy that interferes with nearby electronic devices. Chokes, line reactors, and filters are sometimes used to suppress the transmission of harmonics in an electrical system. See also *Choke*.
- Horsepower** A unit of physical measure to quantify the amount of work done per unit of time. You can directly convert between horsepower and Watts as measurements of power.
- IGBT** **Insulated Gate Bipolar Transistor (IGBT)** – A semiconductor transistor capable of conducting very large currents when in saturation and capable of withstanding very high voltages when it is OFF. This high-power bipolar transistor is the type used in Hitachi inverters.
- Inertia** The natural resistance a stationary object to being moved by an external force. See also *Momentum*.
- Intelligent Terminal** A configurable input or output logic function on the Hitachi inverters. Each terminal may be assigned one of several functions.
- Inverter** A device that electronically changes DC to AC current through an alternating process of switching the input to the output, inverted and non-inverted. A variable speed drive such as the Hitachi SJ100 is also called an inverter, since it contains three inverter circuits to generate 3-phase output to the motor.
- Isolation Transformer** A transformer with 1:1 voltage ratio that provides electrical isolation between its primary and secondary windings. These are typically used on the power input side of the device to be protected. An isolation transformer can protect equipment from a ground fault or other malfunction of nearby equipment, as well as attenuate harmful harmonics and transients on the input power.
- Jogging Operation** Usually done manually, a jog command from an operator's panel requests the motor/drive system to run indefinitely in a particular direction, until the machine operator ends the jog operation.

Jump Frequency	A <i>jump frequency</i> is a point on the inverter output frequency range that you want the inverter to skip around. This feature may be used to avoid a resonant frequency, and you can program up to three jump frequencies in the inverter.
Line Reactor	A three-phase inductor generally installed in the AC input circuit of an inverter to minimize harmonics and to limit short-circuit current.
Momentum	The physical property of a body in motion that causes it to remain in motion. In the case of motors, the rotor and attached load are rotating and possesses angular momentum.
Multi-speed Operation	The ability of a motor drive to store preset discrete speed levels for the motor, and control motor speed according to the currently selected speed preset. The Hitachi inverters have 16 preset speeds.
Motor Load	In motor terminology, motor load consists of the inertia of the physical mass that is moved by the motor and the related friction from guiding mechanisms. See also <i>Inertia</i> .
NEC	The National Electric Code is a regulatory document that governs electrical power and device wiring and installation in the United States.
NEMA	The National Electric Manufacturer's Association. NEMA Codes are a published series of device ratings standards. Industry uses these to evaluate or compare the performance of devices made by various manufacturers to a known standard.
Open-collector Outputs	A common logic-type discrete output that uses an NPN transistor that acts as a switch to a power supply common, usually ground. The transistor's <i>collector</i> is <i>open</i> for external connection (not connected internally). Thus, the output <i>sinks</i> external load current to ground.
Power Factor	A ratio that expresses a phase difference (timing offset) between current and voltage supplied by a power source to a load. A perfect power factor = 1.0 (no phase offset). Power factors less than one cause some energy loss in power transmission wiring (source to load).
PID Loop	Proportional - Integral-Derivative - A mathematical model used for process control. A process controller maintains a process variable (PV) at a setpoint (SP) by using its PID algorithm to compensate for dynamic conditions and vary its output to drive the PV toward the desired value. For variable-frequency drives, the process variable is the motor speed. See also <i>Error</i> .
Process Variable	A physical property of a process that is of interest because it affects the quality of the primary task accomplished by the process. For an industrial oven, temperature is the process variable. See also <i>PID Loop</i> and <i>Error</i> .

PWM	Pulse-width modulation: A type of AC adjustable frequency drive that accomplishes frequency and voltage control at the output section (inverter) of the drive. The drive output voltage waveform is at a constant amplitude, and by “chopping” the waveform (pulse-width-modulating), the average voltage is controlled. The chopping frequency is sometimes called the <i>Carrier Frequency</i> .
Reactance	The impedance of inductors and capacitors has two components. The resistive part is constant, while the reactive part changes with applied frequency. These devices have a complex impedance (complex number), where the resistance is the real part and the reactance is the imaginary part.
Rectifier	An electronic device made of one or more diodes that converts AC power into DC power. Rectifiers are usually used in combination with capacitors to filter (smooth) the rectified waveform to closely approximate a pure DC voltage source.
Regenerative Braking	A particular method of generating reverse torque to a motor, an inverter will switch internally to allow the motor to become a generator and will either store the energy internally, deliver the braking energy back to the main power input, or dissipate it with a resistor.
Regulation	The quality of control applied to maintain a parameter of interest at a desired value. Usually expressed as a percent (\pm) from the nominal, motor regulation usually refers to its shaft speed.
Reverse Torque	The torque applied in the direction opposite to motor shaft rotation. As such, reverse torque is a decelerating force on the motor and its external load.
Rotor	The windings of a motor that rotate, being physically coupled to the motor shaft. See also <i>Stator</i> .
Saturation Voltage	For a transistor semiconductor device, it is in saturation when an increase in input current no longer results in an increase in the output current. The saturation voltage is the voltage drop across the device. The ideal saturation voltage is zero.
Sensorless Vector Control	A technique used in variable-frequency drives to rotate the force vector in the motor without the use of a shaft position sensor (angular). Benefits include an increase in torque at the lowest speed and the cost savings from the lack of a shaft position sensor.
Setpoint (SP)	The <i>setpoint</i> is the desired value of a process variable of interest. See also <i>Process Variable (PV)</i> and <i>PID Loop</i> .

Single-phase power	An AC power source consisting of Hot and Neutral wires. An Earth Ground connection usually accompanies them. In theory, the voltage potential on Neutral stays at or near Earth Ground, while Hot varies sinusoidally above and below Neutral. This power source is named Single Phase to differentiate it from three-phase power sources. Some Hitachi inverters can accept single phase input power, but they all output three-phase power to the motor. See also <i>Three-phase</i> .
Slip	The difference between the theoretical speed of a motor at no load (determined by its inverter output waveforms) and the actual speed. Some slip is essential in order to develop torque to the load, but too much will cause excessive heat in the motor windings and/or cause the motor to stall.
Squirrel Cage	A “nick-name” for the appearance of the rotor frame assembly for an AC induction motor.
Stator	The windings in a motor that are stationary and coupled to the power input of the motor. See also <i>Rotor</i> .
Tachometer	1. A signal generator usually attached to the motor shaft for the purpose of providing feedback to the speed controlling device of the motor. 2. A speed-monitoring test meter that may optically sense shaft rotation speed and display it on a readout.
Thermal Switch	An electromechanical safety device that opens to stop current flow when the temperature at the device reaches a specific temperature threshold. Thermal switches are sometimes installed in the motor in order to protect the windings from heat damage. The inverter can use thermal switch signals to trip (shut down) if the motor overheats. See also <i>Trip</i> .
Thermistor	A type of temperature sensor that changes its resistance according to its temperature. The sensing range of thermistors and their ruggedness make them ideal for motor overheating detection. Hitachi inverters have built-in thermistor input circuits, which can detect an overheated motor and shut off (trip) the inverter output.
Three-phase power	An AC power source with three Hot connections that have phase offsets of 120 degrees is a 3-phase power source. Usually, Neutral and Earth Ground wires accompany the three Hot connections. Loads may be configured in a delta or Y configuration. A Y-connected load such as an AC induction motor will be a balanced load; the currents in all the Hot connections are the same. Therefore, the Neutral connection is theoretically zero. This is why inverters that generate 3-phase power for motors do not generally have a Neutral connection to the motor. However, the Earth Ground connection is important for safety reasons, and is provided.

Torque

The rotational force exerted by a motor shaft. The units of measurement consist of the distance (radius from shaft center axis) and force (weight) applied at that distance. Units are usually given as pound-feet, ounce-inches, or Newton-meters.

Transistor

A solid state, three-terminal device that provides amplification of signals and can be used for switching and control. While transistors have a linear operating range, inverters use them as high-powered switches. Recent developments in power semiconductors have produced transistors capable of handling high voltages and currents, all with high reliability. The saturation voltage has been decreasing, resulting in less heat dissipation. Hitachi inverters use state-of-the-art semiconductors to provide high performance and reliability in a compact package. See also *IGBT* and *Saturation Voltage*.

Trip

An event that causes the inverter to stop operation is called a “trip” event (as in *tripping* a circuit breaker). The inverter keeps a history log of trip events. They also require an action to clear.

Watt Loss

A measure of the internal power loss of a component, the difference between the power it consumes and what its output delivers. An inverter’s watt loss is the input power minus the power delivered to the motor. The watt loss is typically highest when an inverter is delivering its maximum output. Therefore, watt loss is usually specified for a particular output level. Inverter watt loss specifications are important when designing enclosures.

Bibliography

Title	Author and Publisher
Variable Speed Drive Fundamentals, 2nd Ed.	Phipps, Clarence A. The Fairmont Press, Inc. / Prentice-Hall, Inc. 1997 ISBN 0-13-636390-3
Electronic Variable Speed Drives	Brumbach, Michael E. Delmar Publishers 1997 ISBN 0-8273-6937-9
Hitachi Inverter Technical Guide Book	Published by Hitachi, Ltd. Japan 1995 Publication SIG-E002

Drive Parameter Settings Tables

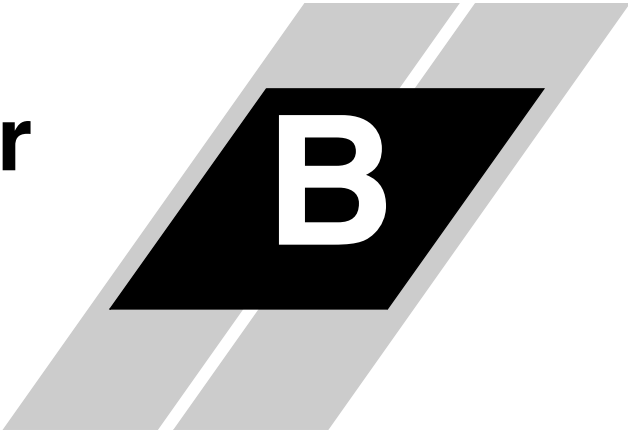

In This Appendix....	page
— Introduction	2
— Parameter Settings for Keypad Entry	2

Introduction

This appendix lists the user-programmable parameters for the SJ100 series inverters and the default values for European and U.S. product types. The right-most column of the tables is blank, so you can record values you have changed from the default. This involves just a few parameters for most applications. This appendix presents the parameters in a format oriented toward the keypad on the inverter.

Parameter Settings for Keypad Entry

SJ100 series inverters provide many functions and parameters that can be configured by the user. We recommend that you record all parameters that have been edited, in order to help in troubleshooting or recovery from a loss of parameter data.

Inverter model	SJ100		}	This information is printed on the specification label located on the right side of the inverter.
MFG. No.				

Main Profile Parameters

"F" Group Parameters		Default Setting			User Setting
Func. Code	Name	-FE (Europe)	-FU (USA)	-FR (Japan)	
F_01	Output frequency setting	0.0	0.0	0.0	
F_02	Acceleration (1) time setting	10.0	10.0	10.0	
F202	Acceleration (1) time setting, 2nd motor	10.0	10.0	10.0	
F_03	Deceleration (1) time setting	10.0	10.0	10.0	
F203	Deceleration (1) time setting, 2nd motor	10.0	10.0	10.0	
F_04	Keypad Run key routing	00	00	00	

Standard Functions

“A” Group Parameters		Default Setting			User Setting
Func. Code	Name	-FE (Europe)	-FU (USA)	-FR (Japan)	
A_01	Frequency source setting	01	01	00	
A_02	Run command source setting	01	01	02	
A_03	Base frequency setting	50.0	60.0	60.0	
A203	Base frequency setting, 2nd motor	50.0	60.0	60.0	
A_04	Maximum frequency setting	50.0	60.0	60.0	
A204	Maximum frequency setting, 2nd motor	50.0	60.0	60.0	
A_11	O-L input active range start frequency	0	0	0	
A_12	O-L input active range end frequency	0	0	0	
A_13	O-L input active range start voltage	0	0	0	
A_14	O-L input active range end voltage	100	100	100	
A_15	O-L input start frequency enable	01	01	01	
A_16	External frequency filter time constant	8	8	8	
A_20	Multi-speed 0 setting	0	0	0	
A220	Multi-speed 0 setting, 2nd motor	0	0	0	
A_21	Multi-speed 1 setting	0	0	5	
A_22	Multi-speed 2 setting	0	0	10	
A_23	Multi-speed 3 setting	0	0	15	
A_24	Multi-speed 4 setting	0	0	20	
A_25	Multi-speed 5 setting	0	0	30	
A_26	Multi-speed 6 setting	0	0	40	
A_27	Multi-speed 7 setting	0	0	50	
A_28	Multi-speed 8 setting	0	0	60	
A_29	Multi-speed 9 setting	0	0	0	
A_30	Multi-speed 10 setting	0	0	0	
A_31	Multi-speed 11 setting	0	0	0	
A_32	Multi-speed 12 setting	0	0	0	

“A” Group Parameters		Default Setting			User Setting
Func. Code	Name	-FE (Europe)	-FU (USA)	-FR (Japan)	
A_33	Multi-speed 13 setting	0	0	0	
A_34	Multi-speed 14 setting	0	0	0	
A_35	Multi-speed 15 setting	0	0	0	
A_38	Jog frequency setting	1.0	1.0	1.0	
A_39	Jog stop mode	00	00	00	
A_41	Torque boost method selection	00	00	00	
A241	Torque boost method selection, 2nd motor	00	00	00	
A_42	Manual torque boost value	11	11	11	
A242	Manual torque boost value, 2nd motor	11	11	11	
A_43	Manual torque boost frequency adjustment	10.0	10.0	10.0	
A243	Manual torque boost frequency adjustment, 2nd motor	10.0	10.0	10.0	
A_44	V/f characteristic curve selection	02	02	02	
A244	V/f characteristic curve selection, 2nd motor	02	02	02	
A_45	V/f gain setting	100	100	100	
A_51	DC braking enable	00	00	00	
A_52	DC braking frequency setting	0.5	0.5	0.5	
A_53	DC braking wait time	0.0	0.0	0.0	
A_54	DC braking force during deceleration	0	0	0	
A_55	DC braking time for deceleration	0.0	0.0	0.0	
A_61	Frequency upper limit setting	0.0	0.0	0.0	
A_62	Frequency lower limit setting	0.0	0.0	0.0	
A_63, A_65, A_67	Jump (center) frequency setting	0.0	0.0	0.0	
A_64, A_66, A_68	Jump (hysteresis) frequency width setting	0.5	0.5	0.5	
A_71	PID Enable	00	00	00	
A_72	PID proportional gain	1.0	1.0	1.0	

“A” Group Parameters		Default Setting			User Setting
Func. Code	Name	-FE (Europe)	-FU (USA)	-FR (Japan)	
A_73	PID integral time constant	1.0	1.0	1.0	
A_74	PID derivative gain	0.0	0.0	0.0	
A_75	PV scale conversion	1.00	1.00	1.00	
A_76	PV source setting	00	00	00	
A_81	AVR function select	02	00	02	
A_82	AVR voltage select	230/400	230/460	200/400	
A_92	Acceleration (2) time setting	15.0	15.0	15.0	
A292	Acceleration (2) time setting, (2nd motor)	15.0	15.0	15.0	
A_93	Deceleration (2) time setting	15.0	15.0	15.0	
A293	Deceleration (2) time setting, (2nd motor)	15.0	15.0	15.0	
A_94	Select method to switch to Acc2/Dec2 profile	00	00	00	
A294	Select method to switch to Acc2/Dec2 profile, 2nd motor	00	00	00	
A_95	Acc1 to Acc2 frequency transition point	0.0	0.0	0.0	
A295	Acc1 to Acc2 frequency transition point, 2nd motor	0.0	0.0	0.0	
A_96	Dec1 to Dec2 frequency transition point	0.0	0.0	0.0	
A296	Dec1 to Dec2 frequency transition point, 2nd motor	0.0	0.0	0.0	
A_97	Acceleration curve selection	00	00	00	
A_98	Deceleration curve selection	00	00	00	

Fine Tuning Functions

“B” Group Parameters		Default Setting			User Setting
Func. Code	Name	-FE (Europe)	-FU (USA)	-FR (Japan)	
B_01	Selection of automatic restart mode	00	00	00	
B_02	Allowable under-voltage power failure time	1.0	1.0	1.0	
B_03	Retry wait time before motor restart	1.0	1.0	1.0	
B_12	Level of electronic thermal setting	Rated current for each inverter	Rated current for each inverter	Rated current for each inverter	
B212	Level of electronic thermal setting, 2nd motor	Rated current for each inverter	Rated current for each inverter	Rated current for each inverter	
B_13	Electronic thermal characteristic	01	01	00	
B213	Electronic thermal characteristic, 2nd motor	01	01	00	
B_21	Overload restriction operation mode	01	01	01	
B_22	Overload restriction setting	Rated current x 1.25	Rated current x 1.25	Rated current x 1.25	
B_23	Deceleration rate at overload restriction	1.0	1.0	1.0	
B_31	Software lock mode selection	01	01	01	
B_81	[FM] terminal analog meter adjustment	80	80	80	
B_82	Start frequency adjustment	0.5	0.5	0.5	
B_83	Carrier frequency setting	5.0	5.0	12.0	
B_84	Initialization mode (parameters or trip history)	00	00	00	
B_85	Country code for initialization	01	02	00	
B_86	Frequency scaling conversion factor	1.0	1.0	1.0	
B_87	STOP key enable	00	00	00	
B_88	Restart mode after FRS	00	00	00	

"B" Group Parameters		Default Setting			User Setting
Func. Code	Name	-FE (Europe)	-FU (USA)	-FR (Japan)	
B_89	Data select for digital op. OPE-J	01	01	01	
B_90	Dynamic braking usage ratio	0.0	0.0	0.0	
B_91	Stop mode selection	00	00	00	
B_92	Cooling fan control	00	00	00	

Intelligent Terminal Functions

“C” Group Parameters		Default Setting			User Setting
Func. Code	Name	-FE (Europe)	-FU (USA)	-FR (Japan)	
C_01	Terminal [1] function	00	00	00	
C_02	Terminal [2] function	01	01	01	
C_03	Terminal [3] function	02	16	02	
C_04	Terminal [4] function	03	13	03	
C_05	Terminal [5] function	18	09	09	
C_06	Terminal [6] function	09	18	18	
C_11	Terminal [1] active state	00	00	00	
C_12	Terminal [2] active state	00	00	00	
C_13	Terminal [3] active state	00	00	00	
C_14	Terminal [4] active state	00	01	00	
C_15	Terminal [5] active state	00	00	00	
C_16	Terminal [6] active state	00	00	00	
C_21	Terminal [11] function	01	01	01	
C_22	Terminal [12] function	00	00	00	
C_23	[FM] signal selection	00	00	00	
C_24	Alarm relay terminal function	05	05	05	
C_31	Terminal [11] active state (-FU)	—	00	—	
	Reserved (-FE / FR)	00	—	00	
C_32	Terminal [12] active state (-FU)	—	00	—	
	Terminal [11] active state (-FE / FR)	00	—	00	
C_33	Alarm relay terminal active state	01	01	01	
C_41	Overload level setting	Inverter rated current	Inverter rated current	Inverter rated current	
C_42	Frequency arrival setting for accel	0.0	0.0	0.0	
C_43	Arrival frequency setting for decel	0.0	0.0	0.0	
C_44	PID deviation level setting	3.0	3.0	3.0	
C_81	O input span calibration	Factory-set	Factory-set	Factory-set	
C_82	OI input span calibration	Factory-set	Factory-set	Factory-set	

“C” Group Parameters		Default Setting			User Setting
Func. Code	Name	-FE (Europe)	-FU (USA)	-FR (Japan)	
C_91	Debug mode enable	00	00	00	Do not edit
C_92	Core monitor address	0000	0000	0000	Do not edit
C_93	Core monitor date	—	—	—	Do not edit
C_94	Core set address	d001	d001	d001	Do not edit
C_95	Core set date	00	00	00	Do not edit

Motor Constants Functions

“H” Group Parameters		Default Setting			User Setting
Func. Code	Name	-FE (Europe)	-FU (USA)	-FR (Japan)	
H_01	Auto-tuning Setting	00	00	00	
H_02	Motor data selection	00	00	00	
H202	Motor data selection, 2nd motor	00	00	00	
H_03	Motor capacity	Specified by the inverter capacity	Specified by the inverter capacity	Specified by the inverter capacity	
H203	Motor capacity, 2nd setting	Specified by the inverter capacity	Specified by the inverter capacity	Specified by the inverter capacity	
H_04	Motor poles setting	4	4	4	
H204	Motor poles setting, 2nd motor	4	4	4	
H_05	Motor constant Kp	20	20	20	
H205	Motor constant Kp, 2nd motor	20	20	20	
H_06	Motor stabilization constant	100	100	100	
H206	Motor stabilization constant, 2nd motor	100	100	100	
H_20	Motor constant R1	Factory set	Factory set	Factory set	
H220	Motor constant R1, 2nd motor	Factory set	Factory set	Factory set	
H_21	Motor constant R2	Factory set	Factory set	Factory set	
H221	Motor constant R2, 2nd motor	Factory set	Factory set	Factory set	

“H” Group Parameters		Default Setting			User Setting
Func. Code	Name	-FE (Europe)	-FU (USA)	-FR (Japan)	
H_22	Motor constant L	Factory set	Factory set	Factory set	
H222	Motor constant L, 2nd motor	Factory set	Factory set	Factory set	
H_23	Motor constant Io	Factory set	Factory set	Factory set	
H223	Motor constant Io, 2nd motor	Factory set	Factory set	Factory set	
H_24	Motor Constant J	Factory set	Factory set	Factory set	
H224	Motor constant J, 2nd motor	Factory set	Factory set	Factory set	
H_30	Auto-tuned motor constant R1	Factory set	Factory set	Factory set	
H230	Auto-tuned motor constant R1, 2nd motor	Factory set	Factory set	Factory set	
H_31	Auto-tuned motor constant R2	Factory set	Factory set	Factory set	
H231	Auto-tuned motor constant R2, 2nd motor	Factory set	Factory set	Factory set	
H_32	Auto-tuned motor constant L	Factory set	Factory set	Factory set	
H232	Auto-tuned motor constant L, 2nd motor	Factory set	Factory set	Factory set	
H_33	Auto-tuned motor constant Io	Factory set	Factory set	Factory set	
H233	Auto-tuned motor constant Io, 2nd motor	Factory set	Factory set	Factory set	
H_34	Auto-tuned motor constant J	Factory set	Factory set	Factory set	
H234	Auto-tuned motor constant J, 2nd motor	Factory set	Factory set	Factory set	

CE–EMC Installation Guidelines

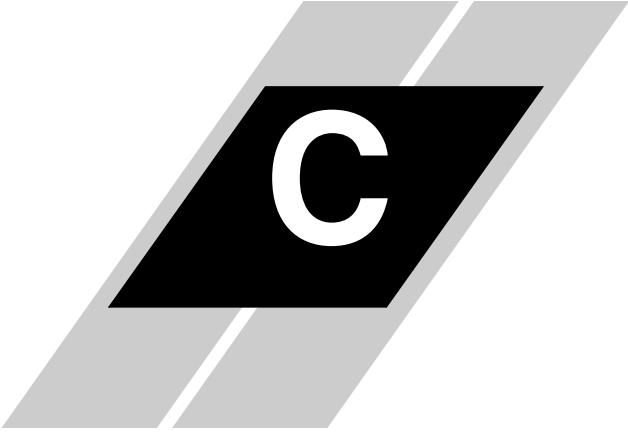

In This Appendix....	page
— CE–EMC Installation Guidelines	2
— Hitachi EMC Recommendations	6

CE-EMC Installation Guidelines

You are required to satisfy the EMC directive (89/336/EEC) when using an SJ100 inverter in an EU country. To satisfy the EMC directive and to comply with standard, follow the guidelines in this section.

1. As user you must ensure that the HF (high frequency) impedance between adjustable frequency inverter, filter, and ground is as small as possible.
 - Ensure that the connections are metallic and have the largest possible contact areas (zinc-plated mounting plates).
2. Avoid conductor loops that act like antennas, especially loops that encompass large areas.
 - Avoid unnecessary conductor loops.
 - Avoid parallel arrangement of low-level signal wiring and power-carrying or noise-prone conductors.
3. Use shielded wiring for the motor cable and all analog and digital control lines.
 - Allow the effective shield area of these lines to remain as large as possible; i.e., do not strip away the shield (screen) further away from the cable end than absolutely necessary.
 - With integrated systems (for example, when the adjustable frequency inverter is communicating with some type of supervisory controller or host computer in the same control cabinet and they are connected at the same ground + PE-potential), connect the shields of the control lines to ground + PE (protective earth) at both ends. With distributed systems (for example the communicating supervisory controller or host computer is not in the same control cabinet and there is a distance between the systems), we recommend connecting the shield of the control lines only at the end connecting to the adjustable frequency inverter. If possible, route the other end of the control lines directly to the cable entry section of the supervisory controller or host computer. The shield conductor of the motor cables always must connected to ground + PE at both ends.
 - To achieve a large area contact between shield and ground + PE-potential, use a PG screw with a metallic shell, or use a metallic mounting clip.
 - Use only cable with braided, tinned copper mesh shield (type “CY”) with 85% coverage.
 - The shielding continuity should not be broken at any point in the cable. If the use of reactors, contactors, terminals, or safety switches in the motor output is necessary, the unshielded section should be kept as short as possible.
 - Some motors have a rubber gasket between terminal box and motor housing. Very often, the terminal boxes, and particularly the threads for the metal PG screw connections, are painted. Make sure there is always a good metallic connection between the shielding of the motor cable, the metal PG screw connection, the terminal box, and the motor housing. If necessary, carefully remove paint between conducting surfaces.

4. Take measures to minimize interference that is frequently coupled in through installation cables.
 - Separate interfering cables with 0.25m minimum from cables susceptible to interference. A particularly critical point is laying parallel cables over longer distances. If two cables intersect (one crosses over the other), the interference is smallest if they intersect at an angle of 90°. Cables susceptible to interference should therefore only intersect motor cables, intermediate circuit cables, or the wiring of a rheostat at right angles and never be laid parallel to them over longer distances.
5. Minimize the distance between an interference source and an interference sink (interference-threatened device), thereby decreasing the effect of the emitted interference on the interference sink.
 - You should use only interference-free devices and maintain a minimum distance of 0.25 m from the adjustable frequency inverter.
6. Follow safety measures in the filter installation.
 - Ensure that the ground terminal (PE) of the filter is properly connected to the ground terminal of the adjustable frequency inverter. An HF ground connection via metal contact between the housings of the filter and the adjustable frequency inverter, or solely via cable shield, is not permitted as a protective conductor connection. The filter must be solidly and permanently connected with the ground potential so as to preclude the danger of electric shock upon touching the filter if a fault occurs.

To achieve a protective ground connection for the filter:

- Ground the filter with a conductor of at least 10 mm² cross-sectional area.
- Connect a second grounding conductor, using a separate grounding terminal parallel to the protective conductor. (The cross section of each single protective conductor terminal must be sized for the required nominal load.)

SJ100 inverter with footprint-type filter

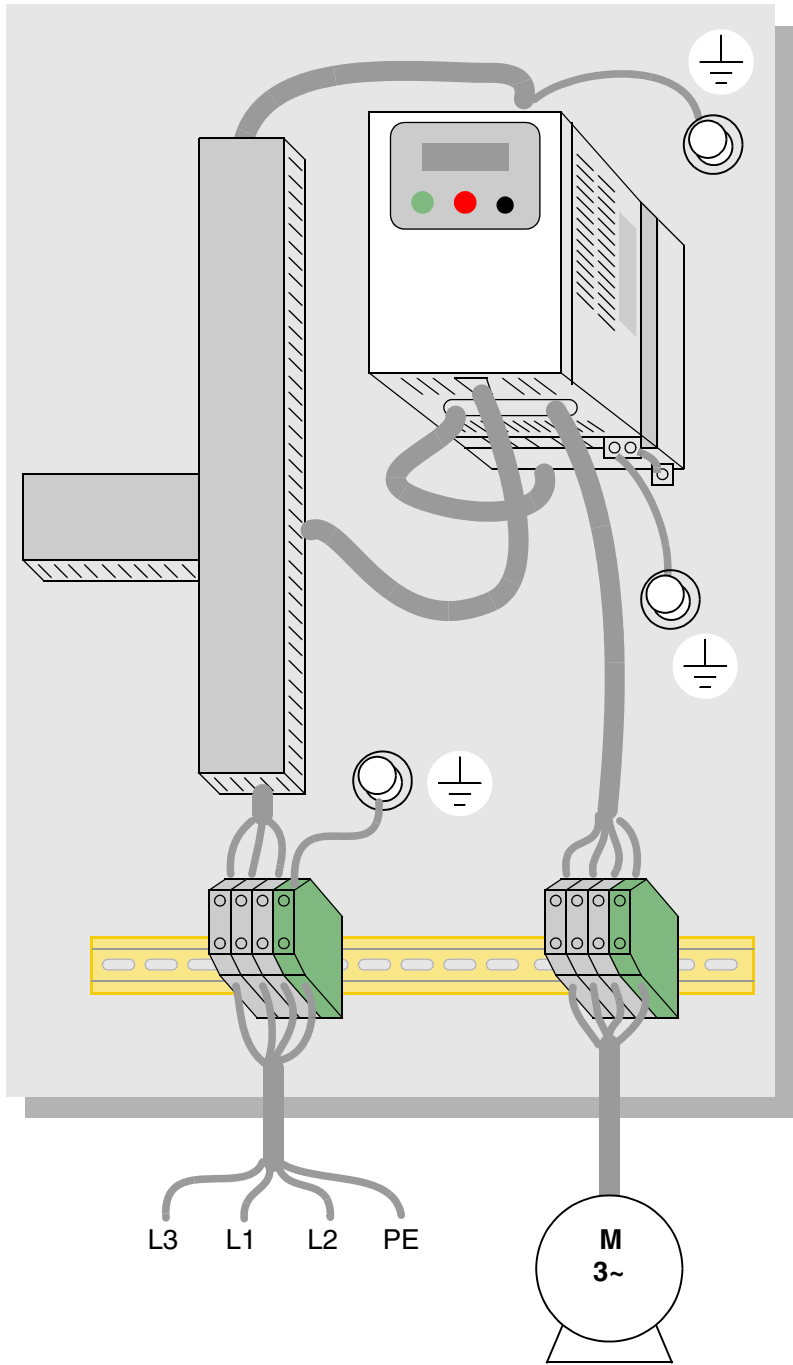

SJ100 inverter with book-type filter

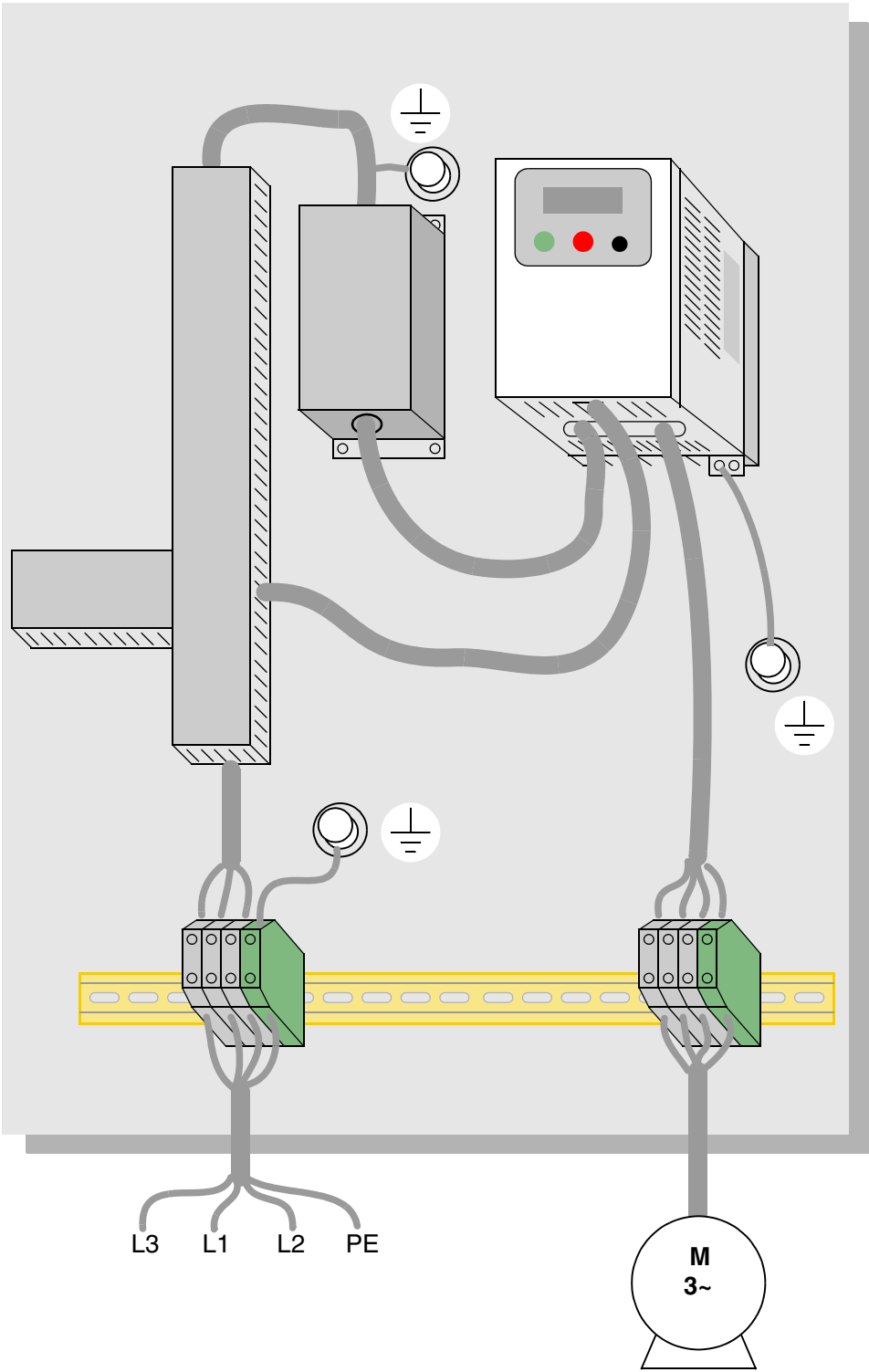

Hitachi EMC Recommendations



WARNING: This equipment should be installed, adjusted, and serviced by qualified personal familiar with construction and operation of the equipment and the hazards involved. Failure to observe this precaution could result in bodily injury.

Use the following checklist to ensure the inverter is within proper operating ranges and conditions.

1. The power supply to SJ100 inverters must meet these specifications:
 - Voltage fluctuation $\pm 10\%$ or less
 - Voltage imbalance $\pm 3\%$ or less
 - Frequency variation $\pm 4\%$ or less
 - Voltage distortion THD = 10% or less
2. Installation measure:
 - Use a filter designed for SJ100 inverter.
3. Wiring:
 - Shielded wire (screened cable) is required for motor wiring, and the length must be less than 50 meters.
 - The carrier frequency setting must be less than 5 kHz to satisfy EMC requirements.
 - Separate the power input and motor wiring from the signal/process circuit wiring.
4. Environmental conditions—when using a filter, follow these guidelines:
 - Ambient temperature: -10 to 40 °C
 - Humidity: 20 to 90% RH (non-condensing)
 - Vibration: 5.9 m/sec^2 (0.6 G) 10 ~ 55Hz
 - Location: 1000 meters or less altitude, indoors (no corrosive gas or dust)

Index

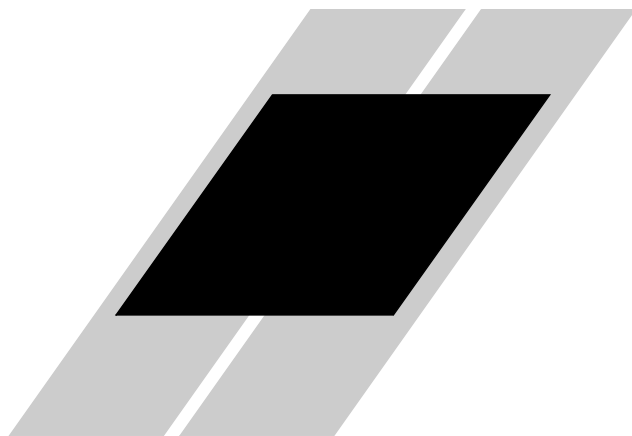

A

A Group functions [3-9](#)
AC reactors [5-3](#)
Acceleration [1-21](#), [3-8](#)
 characteristic curves [3-23](#)
 second function [3-21](#)
 two-stage [4-15](#)
Access levels [3-5](#), [3-28](#), [4-19](#)
Access to terminals [2-2](#)
Accessories [5-2](#)
Alarm signal [4-30](#)
Algorithms [3-43](#)
Algorithms, torque control [3-5](#)
Ambient temperature [2-8](#), [A-2](#)
Analog input settings [3-10](#)
Analog inputs
 current/voltage select [4-20](#)
 operation [4-32](#)
 wiring examples [4-32](#)
Analog outputs
 configuration [3-40](#)
 FM type [4-34](#)
 operation [4-33](#)
 PWM type [4-33](#)
Arrival frequency [A-2](#)
Automatic restart [3-24](#)
Automatic voltage regulation [3-20](#)
Auto-tuning [4-35](#), [A-2](#)
Auto-tuning constants [3-43](#)
AVR [3-20](#)

B

B Group functions [3-24](#)
Base frequency [A-2](#)
Bibliography [A-8](#)

Braking [1-20](#)
 dynamic [5-5](#)
 resistive [1-23](#)
 settings [3-16](#)
Braking resistor [2-5](#), [A-2](#)
Braking resistor selection
 external braking units [5-9](#)
 internal braking units [5-8](#)
Braking unit [2-5](#)
Break-away torque [A-2](#)

C

C Group functions [3-34](#)
Capacitor life curve [6-11](#)
Carrier frequency [3-30](#), [A-2](#)
Catching a spinning motor [3-32](#)
Cautions
 inverter mounting [2-7](#)
 operating procedures [4-2](#)
CE approval [A-2](#)
CE-EMC guidelines [C-2](#)
Chassis ground connection [2-18](#)
Choke [2-5](#), [A-2](#)
Choke, DC link [5-4](#)
Chopper frequency [3-30](#)
Clearance [2-8](#)
Coasting [3-32](#)
Constant torque [3-13](#)
Constant volts/hertz operation [1-18](#)
Contact information [xviii](#)
Control algorithms [3-13](#)
Copy Unit [1-3](#)
Cover removal [2-19](#)
Current overload [3-27](#)

D

- D Group parameters [3–6](#)
- DC braking [3–16](#), [4–12](#), [4–13](#), [A–3](#)
- DC link
 - choke [5–4](#)
- Deadband [A–3](#)
- Deceleration [1–21](#), [3–8](#), [4–12](#)
 - characteristic curves [3–23](#)
 - second function [3–21](#)
 - two-stage [4–15](#)
- Default parameter values [B–2](#)
- Default settings
 - restoring [6–8](#)
- Derating curves [1–11](#)
- Derivative gain [3–19](#)
- Digital operator [2–21](#), [3–3](#)
- Digital operator panel [A–3](#)
- Digital operators [1–3](#)
- Dimensions
 - inverter [2–9](#)
 - terminals [2–15](#)
- Diode [A–3](#)
- Duty cycle [A–3](#)
- Dynamic braking [1–20](#), [5–5](#), [A–3](#)
 - usage ratio [3–33](#), [5–6](#)

E

- Editing parameters [2–21](#), [2–24](#)
 - in Run Mode [3–5](#), [3–28](#), [4–19](#)
- Electromagnetic compatibility [C–2](#)
- Electronic thermal overload [3–25](#)
- EMC installation guidelines [C–2](#)
- EMC installation recommendations [C–6](#)
- EMI [A–3](#)
- EMI filter [5–4](#)
- Environmental specs [1–9](#)
- Error [A–3](#)
 - PID loop [4–29](#)
- Error codes
 - trip events [6–5](#)
- Event clearing [4–21](#)
- External trip [4–17](#)

F

- F Group functions [3–8](#)
- Factory default settings [3–30](#)
- Factory settings, restoring [6–8](#)
- Fan control [3–33](#)
- Fan outlet [2–8](#), [2–19](#)
- FAQ [1–22](#)
- Features [1–2](#), [2–2](#)
- Filters
 - noise suppression [5–2](#)
- Fine-tuning functions [3–24](#)
- Forward run command [4–9](#)
- Four-quadrant operation [A–3](#)
- Free-run stop [3–32](#), [4–12](#), [4–16](#), [A–3](#)
- Frequency arrival signals [4–26](#)
- Frequency display scaling [3–30](#)
- Frequency limits [3–17](#)
- Frequency matching [3–32](#)
- Frequency setting [A–4](#)
- Frequency source setting [3–9](#)
- Frequency-related functions [3–17](#)
- Frequently asked questions [1–22](#)
- Functions [1–20](#), [2–22](#)
- Fuse ratings [2–14](#)

G

- Glossary of terms [A–2](#)

H

- H Group parameters [3–43](#)
- Harmonics [A–4](#)
- History of trip events [3–7](#)
- Horsepower [A–4](#)

I

IGBT [1-17](#), [A-4](#)
test method [6-15](#)
Index of terminal functions [4-7](#)
Inertia [A-4](#)
Initialization [6-8](#)
Initialization codes [3-30](#)
Input circuits [4-8](#)
Input terminals [2-15](#)
Inspection
electrical measurements [6-12](#)
IGBT test method [6-15](#)
measurement techniques [6-14](#)
procedures [6-9](#)
unpacking [2-2](#)
Installation instructions [2-6](#)
Insulation test [6-10](#)
Integral gain [3-19](#)
Intelligent input terminals [3-34](#), [4-8](#)
Intelligent output terminals [3-38](#), [4-24](#)
Intelligent terminal [A-4](#)
Intelligent terminal functions [3-34](#)
Intelligent terminal index [4-7](#)
Inverter [1-22](#), [A-4](#)
Inverter specifications [1-5](#)
Isolation transformer [A-4](#)

J

Jog command [4-12](#)
Jog frequency settings [3-11](#)
Jogging operation [A-4](#)
Jump frequencies [3-18](#)
Jump frequency [A-5](#)

K

Keypad
features [2-21](#), [3-3](#)
navigation [2-23](#), [3-4](#)
navigation, trip events [6-7](#)
Keypad features [2-21](#)
Keypads [1-3](#), [3-2](#)

L

LEDs [2-21](#), [3-3](#)
Line reactor [A-5](#)
Linear accel/decel [3-23](#)
Logic terminals [3-34](#), [3-38](#), [4-6](#)

M

Main profile parameters [3-8](#)
Maintenance procedures [6-9](#)
Megger test [6-10](#)
Model number [1-4](#)
Model number convention [1-4](#)
Momentum [A-5](#)
Monitor mode [2-23](#), [2-27](#), [2-28](#), [3-4](#)
Monitoring functions [3-6](#)
Motor
speed calculation [2-28](#)
Motor constants [3-43](#)
auto-tuning [4-35](#)
Motor load [A-5](#)
Motor poles [1-23](#), [2-26](#)
Motor wiring [2-18](#)
Mounting dimensions [2-9](#)
Mounting location [2-7](#)
Multiple motors
configuration [4-40](#)
Multi-speed operation [4-10](#), [A-5](#)
Multi-speed profiles [1-21](#)
Multi-speed settings [3-11](#)

N

Nameplate [1-4](#)
Navigational map [2-23](#), [3-4](#)
trip events [6-7](#)
NEC [A-5](#)
NEMA [A-5](#)
NEMA rating [2-8](#)
Noise filters [5-2](#)
AC reactor [2-5](#)

O

Open-collector outputs [4-24](#), [A-5](#)
Operational modes [3-5](#)
Operator interfaces [1-3](#)
Optional components [2-5](#)
Options [1-2](#)
Output adjustment parameters [3-41](#)
Output circuits [4-24](#)
Output deviation for PID control [4-29](#)
Output frequency [3-8](#)
Output overload [3-27](#)
Output terminals [2-18](#)
Overload advance notice signal [4-28](#)
Overload restriction [3-27](#)

P

Parameter editing [2-21](#), [2-24](#)
Parameter settings tables [B-2](#)
Parameters [1-20](#), [2-22](#)
PID loop [1-24](#), [A-5](#)
 operation [4-39](#)
 output deviation [4-29](#)
 settings [3-19](#)
PLC, connecting to [4-4](#)
Poles of motor [2-26](#)
Potentiometer [2-25](#), [4-32](#)
Power factor [A-5](#)
Powerup test [2-19](#)
 observations [2-28](#)
Powerup, unattended start [4-18](#)
Process variable [A-5](#)
Program mode [2-23](#), [2-28](#), [3-4](#)
Programming device [3-2](#)
Proportional gain [3-19](#)
Pulse-width modulation [4-33](#)
PV source setting [3-19](#)
PWM [A-6](#)

R

Ratings label [1-4](#)
Reactance [A-6](#)
Read/write copy unit [1-3](#), [3-2](#)
Rectifier [A-6](#)
Reduced torque [3-13](#)
Regenerative braking [A-6](#)
Regulation [A-6](#)
Regulatory agency approvals [1-4](#)
Relay alarm contacts [4-30](#)
Remote control [4-23](#)
Reset function [4-21](#)
Restart Mode [3-32](#)
Reverse run command [4-9](#)
Reverse torque [A-6](#)
Revision history [xvii](#)
RF noise filter [5-4](#)
Rotor [A-6](#)
Run command [4-9](#)
Run command source setting [3-9](#)
Run mode [2-28](#), [3-5](#)
Run signal [4-25](#)
Running the motor [2-27](#)
Run-time edits [3-5](#), [3-28](#), [4-19](#)

S

Safety messages [i](#)
Saturation voltage [A-6](#)
Scaling [3-30](#)
S-curve accel/decel [3-23](#)
Second accel and decel [3-21](#)
Second motor [4-14](#)
Sensorless vector control [3-14](#), [A-6](#)
Set 2nd motor [4-14](#)
Setpoint [A-6](#)
Single-phase power [A-7](#)
Sinking I/O [4-4](#)
Slip [A-7](#)
Software lock [3-5](#), [3-28](#), [4-19](#)
Sourcing I/O [4-4](#)
Spare parts [6-11](#)

Specifications

- derating curves [1-11](#)
- general [1-9](#)
- inverter [1-5](#)
- label [1-4](#), [2-3](#)
- logic signals [4-6](#)
- Speed control [1-17](#), [1-21](#), [4-10](#)
- Speed pot [2-25](#)
- Squirrel cage [A-7](#)
- Standard functions [3-9](#)
- Stator [A-7](#)
- Stop command [4-9](#)
- Stop Mode [3-32](#)
- Supply wiring [2-15](#)
- Switching frequency [3-30](#)
- Symbol definitions [i](#)
- System description [2-5](#)

T

- Tachometer [A-7](#)
- Technical support [xviii](#)
- Term definitions [A-2](#)
- Terminal listing [4-7](#)
- Thermal overload [3-25](#)
- Thermal protection [4-22](#)
- Thermal switch [A-7](#)
- Thermistor [A-7](#)
- Thermistor input [4-22](#)
- Three-phase power [A-7](#)
 - motor phase connections [1-18](#)
- Torque [1-18](#), [A-8](#)
- Torque boost [3-13](#)
- Torque control algorithms [3-5](#), [3-13](#), [3-43](#)
- Torque specs, terminals [2-15](#)
- Transistor [A-8](#)
- Trip [A-8](#)
- Trip events [3-7](#)
 - clearing [6-5](#)
 - error codes [6-5](#)
 - external [4-17](#)
 - monitoring [6-5](#)
- Trip history [6-7](#)
- Trip mode [4-21](#)
- Troubleshooting tips [6-3](#)
- Two-stage accel/decel [4-15](#)

U

- UL instructions [xii](#)
- Unattended start protection [4-18](#)
- Unpacking [2-2](#)
- Up/Down functions [4-23](#)

V

- V/f control [3-13](#)
- Variable torque [3-13](#)
- Variable-frequency drives
 - introduction [1-17](#)
- Velocity profile [1-21](#)
- Ventilation [2-8](#), [2-19](#)
- Voltage gain [3-14](#)

W

- Warnings
 - operating procedures [4-3](#)
 - troubleshooting [6-2](#)
- Warranty [6-16](#)
- Watt loss [A-8](#)
- Wiring
 - analog inputs [4-32](#)
 - gauge [2-14](#)
 - logic [2-18](#)
 - logic connector [4-6](#)
 - output [2-18](#)
 - power input [2-15](#)
 - preparation [2-13](#)
 - system diagram [4-5](#)

Z

- Zero-phase reactor [5-4](#)