

# Troubleshooting and Maintenance



# 6

---

In This Chapter....	page
— Troubleshooting.....	2
— Monitoring Trip Events, History, & Conditions ..	5
— Restoring Factory Default Settings .....	8
— Maintenance and Inspection .....	9
— Warranty .....	16

---

# Troubleshooting

## Safety Messages

Please read the following safety messages before troubleshooting or performing maintenance on the inverter and motor system.



---

**WARNING:** Wait at least five (5) minutes after turning OFF the input power supply before performing maintenance or an inspection. Otherwise, there is the danger of electric shock.

---



---

**WARNING:** Make sure that only qualified personnel will perform maintenance, inspection, and part replacement. Before starting to work, remove any metallic objects from your person (wristwatch, bracelet, etc.). Be sure to use tools with insulated handles. Otherwise, there is a danger of electric shock and/or injury to personnel.

---



---

**WARNING:** Never remove connectors by pulling on its wire leads (wires for cooling fan and logic P.C.board). Otherwise, there is a danger of fire due to wire breakage and/or injury to personnel.

---

## General Precautions and Notes

- Always keep the unit clean so that dust or other foreign matter does not enter the inverter.
- Take special care in regard to breaking wires or making connection mistakes.
- Firmly connect terminals and connectors.
- Keep electronic equipment away from moisture and oil. Dust, steel filings and other foreign matter can damage insulation, causing unexpected accidents, so take special care.

## Inspection Items

This chapter provides instructions or checklists for these inspection items:

- Daily inspection
- Periodic inspection (approximately once a year)
- Insulation resistance test

### Troubleshooting Tips

The table below lists typical symptoms and the corresponding solution(s).

Symptom/condition		Probable Cause	Solution
The motor will not run.	The inverter outputs [U], [V], [W] are not supplying voltage.	<ul style="list-style-type: none"> <li>Is the frequency command source A_01 parameter setting correct?</li> <li>Is the Run command source A_02 parameter setting correct?</li> </ul>	<ul style="list-style-type: none"> <li>Make sure the parameter setting A_01 is correct.</li> <li>Make sure the parameter setting A_02 is correct.</li> </ul>
		<ul style="list-style-type: none"> <li>Is power being supplied to terminals [L1], [L2], and [L3/N]? If so, the POWER lamp should be ON.</li> </ul>	<ul style="list-style-type: none"> <li>Check terminals [L1], [L2], and [L3/N], then [U/T1], [V/T2], and [W/T3].</li> <li>Turn ON the power supply or check fuses.</li> </ul>
		<ul style="list-style-type: none"> <li>Is there an error code <b>EXX</b> displayed?</li> </ul>	<ul style="list-style-type: none"> <li>Press the Func. key and determine the error type. Eliminate the error cause, then clear the error (Reset).</li> </ul>
		<ul style="list-style-type: none"> <li>Are the signals to the intelligent input terminals correct?</li> <li>Is the Run Command active?</li> <li>Is the [FW] terminal (or [RV]) connected to [P24] (via switch, etc.)</li> </ul>	<ul style="list-style-type: none"> <li>Verify the terminal functions for C_01 – C_06 are correct.</li> <li>Turn ON Run Command enable.</li> <li>Supply 24V to {FW} or [RV] terminal, if configured.</li> </ul>
		<ul style="list-style-type: none"> <li>Has the frequency setting for F_01 been set greater than zero?</li> <li>Are the control circuit terminals [H], [O], and [L] connected to the potentiometer?</li> </ul>	<ul style="list-style-type: none"> <li>Set the parameter for F_01 to a safe, non-zero value.</li> <li>If the potentiometer is the frequency setting source, verify voltage at [O] &gt; 0V.</li> </ul>
		<ul style="list-style-type: none"> <li>Is the RS (reset) function or FRS (free-run stop) function ON?</li> </ul>	<ul style="list-style-type: none"> <li>Turn OFF the command(s).</li> </ul>
	Inverter outputs [U], [V], [W] are supplying voltage.	<ul style="list-style-type: none"> <li>Is the motor load too heavy?</li> </ul>	<ul style="list-style-type: none"> <li>Reduce load, and test the motor independently.</li> </ul>
The optional remote operator is used (SRW).	<ul style="list-style-type: none"> <li>Are the operational settings between the remote operator and the inverter unit correct?</li> </ul>	<ul style="list-style-type: none"> <li>Check the operator type setting.</li> </ul>	
The direction of the motor is reversed.	<ul style="list-style-type: none"> <li>Are the connections of output terminals [U/T1], [V/T2], and [W/T3] correct?</li> <li>Is the phase sequence of the motor forward or reverse with respect to [U/T1], [V/T2], and [W/T3]?</li> </ul>	<ul style="list-style-type: none"> <li>Make connections according to the phase sequence of the motor. In general: FWD = U-V-W, and REV=U-W-V.</li> </ul>	
	<ul style="list-style-type: none"> <li>Are the control terminals [FW] and [RV] wired correctly?</li> <li>Is parameter F_04 properly set?</li> </ul>	<ul style="list-style-type: none"> <li>Use terminal [FW] for forward, and [RV] for reverse.</li> <li>Set motor direction in F_04.</li> </ul>	

Symptom/condition		Probable Cause	Solution
The motor speed will not reach the target frequency (desired speed).		<ul style="list-style-type: none"> <li>• If using the analog input, is the current or voltage at [O] or [OI]?</li> </ul>	<ul style="list-style-type: none"> <li>• Check the wiring.</li> <li>• Check the potentiometer or signal generating device.</li> </ul>
		<ul style="list-style-type: none"> <li>• Is the load too heavy?</li> </ul>	<ul style="list-style-type: none"> <li>• Reduce the load.</li> <li>• Heavy loads activate the overload restriction feature (reduces output as needed).</li> </ul>
		<ul style="list-style-type: none"> <li>• Is the inverter internally limiting the output frequency?</li> </ul>	<ul style="list-style-type: none"> <li>• Check max frequency setting (A_04)</li> <li>• Check frequency upper limit setting (A_61)</li> </ul>
The rotation is unstable.		<ul style="list-style-type: none"> <li>• Is the load fluctuation too great?</li> <li>• Is the supply voltage unstable?</li> <li>• Is the problem occurring at a particular frequency?</li> </ul>	<ul style="list-style-type: none"> <li>• Increase the motor capacity (both inverter and motor).</li> <li>• Fix power supply problem.</li> <li>• Change the output frequency slightly, or use the jump frequency setting to skip the problem frequency.</li> </ul>
The RPM of the motor does not match the inverter output frequency setting.		<ul style="list-style-type: none"> <li>• Is the maximum frequency setting A_04 correct?</li> <li>• Does the monitor function D_01 display the expected output frequency?</li> </ul>	<ul style="list-style-type: none"> <li>• Verify the V/f settings match motor specifications.</li> <li>• Make sure all scaling (such as A_11 to A_14) is properly set.</li> </ul>
Inverter data is not correct.	No downloads have occurred.	<ul style="list-style-type: none"> <li>• Was power turned OFF after a parameter edit but before pressing the Store key?</li> </ul>	<ul style="list-style-type: none"> <li>• Edit the data and press the Store key once.</li> </ul>
		<ul style="list-style-type: none"> <li>• Edits to data are permanently stored at power down. Was the time from power OFF to power ON less than six seconds?</li> </ul>	<ul style="list-style-type: none"> <li>• Wait six seconds or more before turning power OFF after editing data.</li> </ul>
	A download to the inverter was attempted.	<ul style="list-style-type: none"> <li>• Was the power turned OFF within six seconds after the display changed from REMT to INV?</li> </ul>	<ul style="list-style-type: none"> <li>• Copy the data to the inverter again, and keep power ON for six seconds or more after copying.</li> </ul>
A parameter will not change after an edit (reverts to old setting).	True for certain parameters	<ul style="list-style-type: none"> <li>• Is the inverter in Run Mode? Some parameters cannot be edited during Run Mode.</li> </ul>	<ul style="list-style-type: none"> <li>• Put inverter in Stop Mode (press the Stop/reset key). Then edit the parameter.</li> </ul>
	True for all parameters	<ul style="list-style-type: none"> <li>• If you're using the [SFT] intelligent input (software lock function)—is the [SFT] input ON?</li> </ul>	<ul style="list-style-type: none"> <li>• Change the state of the SFT input, and check the B_31 parameter (SFT mode).</li> </ul>

# Monitoring Trip Events, History, & Conditions

## Fault Detection and Clearing

The microprocessor in the inverter detects a variety of fault conditions and captures the event, recording it in a history table. The inverter output turns OFF, or “trips” similar to the way a circuit breaker trips due to an over-current condition. Most faults occur when the motor is running (refer to the diagram to the right). However, the inverter could have an internal fault and trip in Stop Mode. In either case, you can clear the fault by pressing the Stop/Reset key. Additionally, you can clear the inverter’s cumulative trip history by performing the procedure “Restoring Factory Default Settings” on page 6–8 (setting B\_84=00 will clear the trip history but leave inverter settings intact).

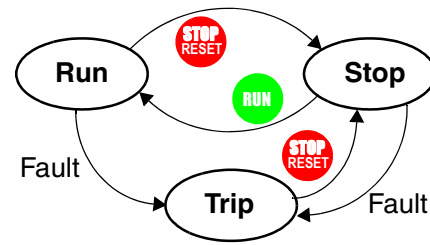

## Error Codes

An error code will appear on the display automatically when a fault causes the inverter to trip. The following table lists the cause associated with the error.

Error Code	Name	Cause(s)
<i>E01</i>	Over current event while at constant speed	The inverter output was short-circuited, or the motor shaft is locked or has a heavy load. These conditions cause excessive current for the inverter, so the inverter output is turned OFF.
<i>E02</i>	Over current event during deceleration	
<i>E03</i>	Over current event during acceleration	
<i>E04</i>	Over current event during other conditions	
<i>E05</i>	Overload protection	When a motor overload is detected by the electronic thermal function, the inverter trips and turns OFF its output.
<i>E06</i>	Braking resistor overload	When the regenerative braking resistor exceeds the usage time allowance or usage ratio, the inverter trips and turns OFF its output to the motor.
<i>E07</i>	Over voltage protection	When the DC bus voltage exceeds a threshold, due to regenerative energy from the motor.
<i>E08</i>	EEPROM error	When the built-in EEPROM memory has problems due to noise or excessive temperature, the inverter trips and turns OFF its output to the motor.
<i>E09</i>	Under-voltage error	A decrease of internal DC bus voltage below a threshold results in a control circuit fault. This condition can also generate excessive motor heat or cause low torque. The inverter trips and turns OFF its output.

Error Code	Name	Cause(s)
<i>E10</i>	CT (current transformer) error	If a strong source of electrical interference is close to the inverter or a fault occurs in a built-in CT (current transformer), the inverter trips and turns its output OFF.
<i>E11</i> <i>E22</i>	CPU error	A malfunction in the built-in CPU has occurred, so the inverter trips and turns OFF its output to the motor.
<i>E12</i>	External trip	A signal on an intelligent input terminal configured as EXT has occurred. The inverter trips and turns OFF the output to the motor.
<i>E13</i>	USP	When the Unattended Start Protection (USP) is enabled, an error occurred when power is applied while a Run signal is present. The inverter trips and does not go into Run Mode until the error is cleared.
<i>E14</i>	Ground fault	The inverter is protected by the detection of ground faults between the inverter output and the motor upon during powerup tests. This feature protects the inverter, and does not protect humans.
<i>E15</i>	Input over-voltage	When the input voltage is higher than the specified value, it is detected 100 seconds after powerup and the inverter trips and turns OFF its output.
<i>E21</i>	Inverter thermal trip	When the inverter internal temperature is above the threshold, the thermal sensor in the inverter module detects the excessive temperature of the power devices and trips, turning the inverter output OFF.
<i>E35</i>	Thermistor	Due to low input voltage, the inverter turns its output OFF and tries to restart. If it fails to restart, then the alarm trips to record the under-voltage error event.
<i>- - - U</i>	Under-voltage (brown-out) with output shutoff	Low input voltage caused the inverter to turn OFF the motor output and try to restart. If unsuccessful, a trip occurs.



**NOTE:** If an EEPROM error (E08) occurs, be sure to confirm the parameter data values are still correct. If the power is turned OFF while the [RS] (Reset) intelligent input terminal is ON, an EEPROM error will occur when power is restored.

### Trip History and Inverter Status





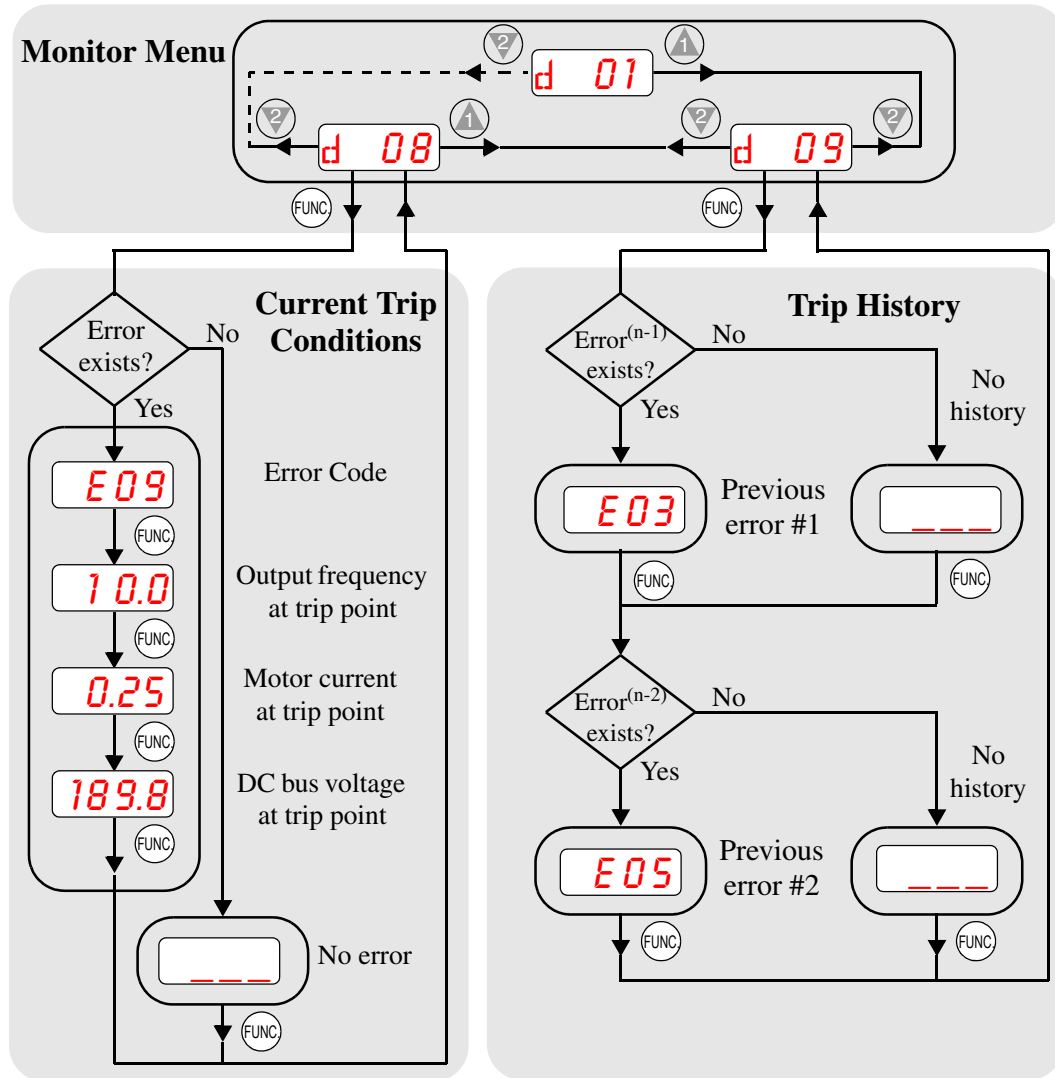







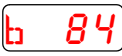

We recommend that you first find the cause of the fault before clearing it. When a fault occurs, the inverter stores important performance data at the moment of the fault. To access the data, use the monitor functions (D\_xx) and select D\_08 for details about the present fault (E<sup>n</sup>), or the error code for the past two trip events (E<sup>n-1</sup> and E<sup>n-2</sup>) using the D\_09 Trip History function.

The following Monitor Menu map shows how to access the error codes. When fault(s) exist, you can review their details by first selecting the proper function: D\_08 displays current trip data, and D\_09 displays trip history.

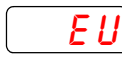

## Restoring Factory Default Settings

You can restore all inverter parameters to the original factory (default) settings for the intended country of use. After initializing the inverter, use the powerup test in Chapter 2 to get the motor running again. To initialize the inverter, follow the steps below.

No.	Action	Display	Func./Parameter
1	Use the <b>FUNC</b> , <b>▲</b> , and <b>▼</b> keys to navigate to the “B” Group.		“B” Group selected
2	Press the <b>FUNC</b> key.		First “B” parameter selected
3	Press and hold the <b>▲</b> key until ->		Country code for initialization selected
4	Press the <b>FUNC</b> key.		00 = Japan, 01 = Europe, 02 = U.S.
5	Confirm the country code is correct. Do not change it unless you are absolutely sure the power input voltage range and frequency match the country code setting. To change the country code, press <b>▲</b> or <b>▼</b> to set, <b>STR</b> to store.		
6	Press the <b>FUNC</b> key.		Country code for initialization selected
7	Press the <b>▼</b> key.		Initialization function selected
8	Press the <b>FUNC</b> key.		00 = initialization disabled, clear trip history only
9	Press the <b>▲</b> key.		01 = initialization enabled
10	Press the <b>STR</b> key.		Initialization now enabled to restore all defaults
11	Press and hold the <b>FUNC</b> , <b>▲</b> , and <b>▼</b> keys. Do not release yet.		First part of special key sequence
12	Holding the keys above, press and hold the  (STOP) key for 3 sec.		Final part of special key sequence
13	Release only the  (STOP) key, and wait for the display <b>d 01</b> to appear and begin blinking.		Initialization begins when display starts blinking
14	Now release the <b>FUNC</b> , <b>▲</b> , and <b>▼</b> keys only after the <b>d 01</b> display function begins blinking.	 	Default parameter country code shown during initialization process (left-most char displays alternating pattern)
15	Initialization is complete.		Function code for output frequency monitor shown



**NOTE:** Initialization cannot be performed with a remote operator panel. Disconnect the device and use the inverter’s front panel keypad.



# Maintenance and Inspection

## Monthly and Yearly Inspection Chart

Item Inspected		Check for...	Inspection Cycle		Inspection Method	Criteria
			Month	Year		
Overall	Ambient environment	Extreme temperatures & humidity	✓		Thermometer, hygrometer	Ambient temperature between -10 to 40°C, non-condensing
	Major devices	Abnormal noise & vib.	✓		Visual and aural	Stable environment for electronic controls
	Power supply voltage	Voltage tolerance	✓		Digital volt meter, measure between inverter terminals [L1], [L2], [L3]	200V class: 200 to 240V 50/60 Hz 400V class: 380 to 460V 50/60 Hz
Main circuit	Ground Insulation	Adequate resistance		✓	Digital volt meter, GND to terminals	5 Meg. Ohms or greater
	Mounting	No loose screws		✓	Torque wrench	M3: 0.5 – 0.6 Nm M4: 0.98 – 1.3 Nm M5: 1.5 – 2.0 Nm
	Components	Overheating		✓	Thermal trip events	No trip events
	Housing	Dirt, dust		✓	Visual	Vacuum dust and dirt
	Terminal block	Secure connections		✓	Visual	No abnormalities
	Smoothing capacitor	Leaking, swelling	✓		Visual	No abnormalities
	Relay(s)	Chattering		✓	Aural	Single click when switching ON or OFF
	Resistors	Cracks or discoloring		✓	Visual	Use Ohm meter to check braking resistors
	Cooling fan	Noise		✓	Power down, manually rotate	Rotation must be smooth
		Dust		✓	Visual	Vacuum to clean
Control circuit	Overall	No odor, discoloring, corrosion		✓	Visual	No abnormalities
	Capacitor	No leaks or deformation	✓		Visual	Undistorted appearance
Display	LEDs	Legibility	✓		Visual	All LED segments work

**Note 1:** The life of a capacitor is affected by the ambient temperature. See “Capacitor Life Curve” on page 6–11.

**Note 2:** The inverter must be cleaned periodically. If dust accumulates on the fan and heat sink, it can cause overheating of the inverter.

## Megger Test

The *megger* is a piece of test equipment that uses a high voltage to determine if an insulation degradation has occurred. For inverters, it is important that the power terminals be isolated from the Earth GND terminal via the proper amount of insulation.

The circuit diagram below shows the inverter wiring for performing the megger test. Just follow the steps to perform the test:

1. Remove power from the inverter and wait at least 5 minutes before proceeding.
2. Open the front housing panel to access the power wiring.
3. Remove all wires to terminals [R, S, T, RB, +1, +, -, U, V, and W]. Most importantly, the input power and motor wires will be disconnected from the inverter.
4. Use a bare wire and short terminals [R, S, T, RB, +1, +, -, U, V, and W] together as shown in the diagram.
5. Connect the megger to the inverter Earth GND and to the shorted power terminals as shown. Then perform the megger test at 500 VDC and verify 5M $\Omega$  or greater resistance.

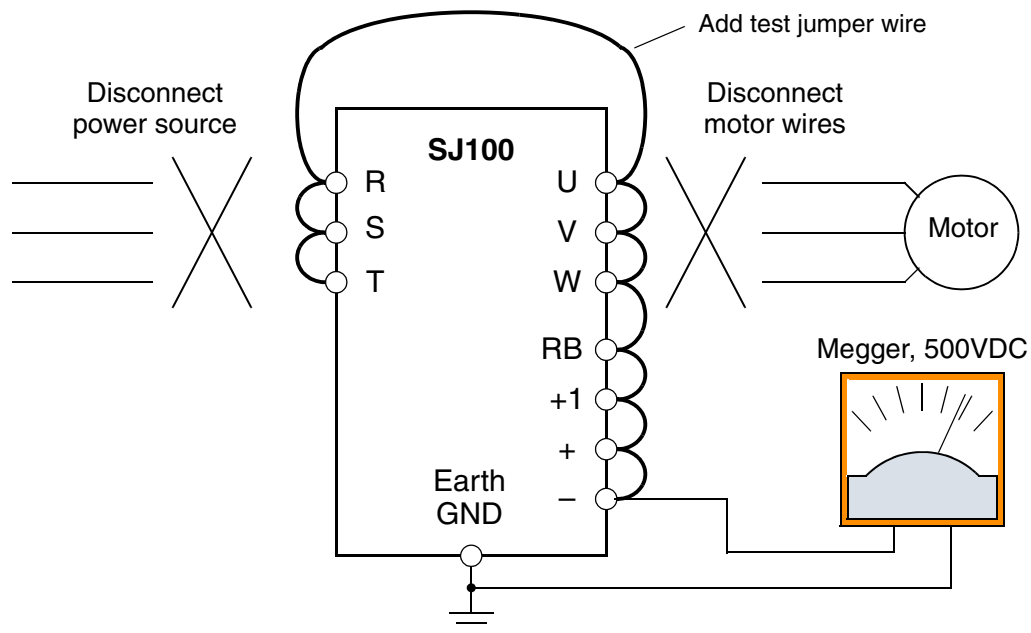

6. After completing the test, disconnect the megger from the inverter.
7. Reconnect the original wires to terminals [R, S, T, RB, +1, +, -, U, V, and W].



**CAUTION:** Do not connect the megger to any control circuit terminals such as intelligent I/O, analog terminals, etc. Doing so could cause damage to the inverter.



**CAUTION:** Never test the withstand voltage (HIPOT) on the inverter. The inverter has a surge protector between the main circuit terminals above and the chassis ground.

### Spare parts

We recommend that you stock spare parts to reduce down time, including these parts:

Part description	Symbol	Quantity		Notes
		Used	Spare	
Cooling fan	FAN	1	1	022NF, 030HF, 037LF, 015HF to 075HF
Case	CV	1	1	<ul style="list-style-type: none"> <li>• Front case</li> <li>• Key cover</li> <li>• Case</li> <li>• Bottom cover</li> </ul>

### Capacitor Life Curve

The DC bus inside the inverter uses a large capacitor as shown in the diagram below. The capacitor handles high voltage and current as it smooths the power for use by the inverter. So, any degradation of the capacitor will affect the performance of the inverter.

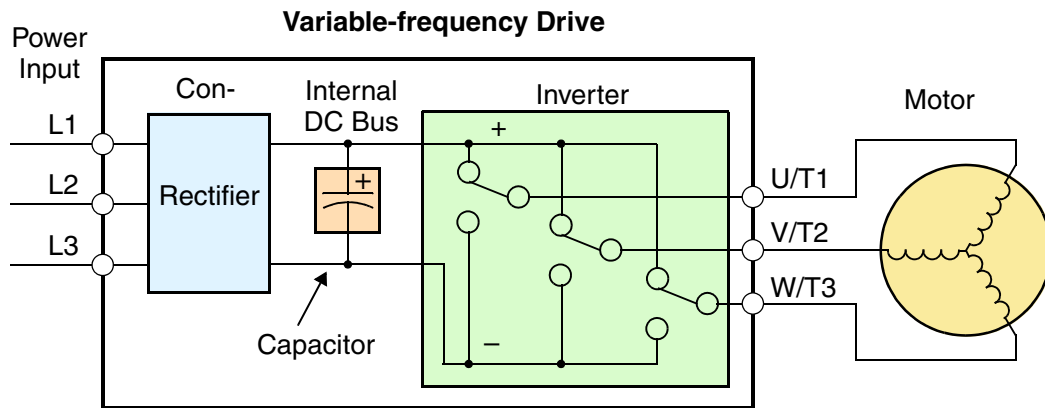

Capacitor life is reduced in higher ambient temperatures, as the graph below demonstrates. Be sure to keep the ambient temperature at acceptable levels, and perform maintenance inspections on the fan, heat sink, and other components. If the inverter is installed on a cabinet, the ambient temperature is the temperature inside the cabinet.

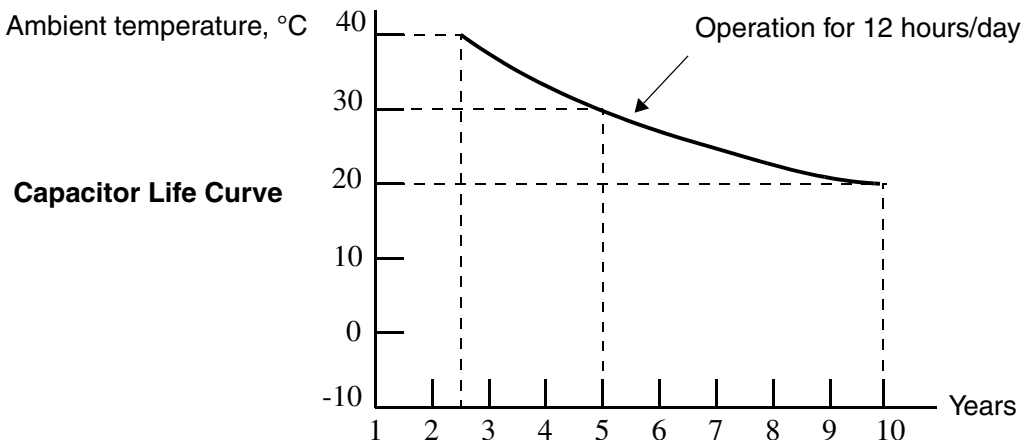

## General Inverter Electrical Measurements

The following table specifies how to measure key system electrical parameters. The diagrams on the next page show inverter-motor systems and the location of measurement points for these parameters.

Parameter	Circuit location of measurement	Measuring instrument	Notes	Reference Value
Supply voltage $E_1$	$E_R$ – across L1 and L2 $E_S$ – across L2 and L3 $E_T$ – across L3 and L1	Moving-coil type voltmeter or rectifier type voltmeter	Fundamental wave effective value	Commercial supply voltage (200V class) 200–240V, 50/60 Hz 400V class 380–460V, 50/60 Hz
Supply current $I_1$	$I_r$ – L1, $I_s$ – L2, $I_t$ – L3		Total effective value	—
Supply power $W_1$	$W_{11}$ – across L1 and L2 $W_{12}$ – across L2 and L3		Total effective value	—
Supply power factor $Pf_1$	$Pf_1 = \frac{W_1}{\sqrt{3} \times E_1 \times I_1} \times 100\%$			—
Output voltage $E_0$	$E_U$ – across U and V $E_V$ – across V and W $E_W$ – across W and U	Rectifier type voltmeter	Total effective value	—
Output current $I_0$	$I_U$ – U $I_V$ – V $I_W$ – W	Moving-coil ammeter	Total effective value	—
Output power $W_0$	$W_{01}$ – across U and V $W_{02}$ – across V and W	Electronic type wattmeter	Total effective value	—
Output power factor $Pf_0$	Calculate the output power factor from the output voltage E, output current I, and output power W. $Pf_0 = \frac{W_0}{\sqrt{3} \times E_0 \times I_0} \times 100\%$			—

- Note 1:** Use a meter indicating a fundamental wave effective value for voltage, and meters indicating total effective values for current and power.
- Note 2:** The inverter output has a distorted waveform, and low frequencies may cause erroneous readings. However, the measuring instruments and methods listed above provide comparably accurate results.
- Note 3:** A general-purpose digital volt meter (DVM) is not usually suitable to measure a distorted waveform (not pure sinusoid).

The figures below show measurement locations for voltage, current, and power measurements listed in the table on the previous page. The voltage to be measured is the fundamental wave effective voltage. The power to be measured is the total effective power.

**Single-phase Measurement Diagram**

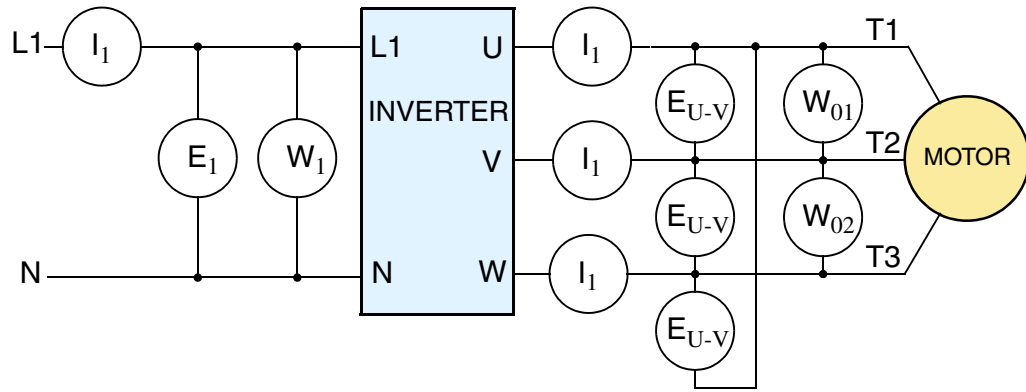

**Three-phase Measurement Diagram**

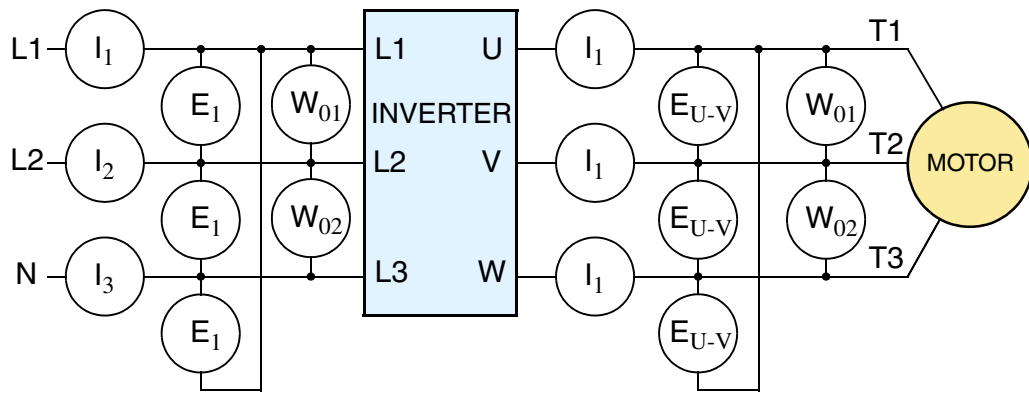

### Inverter Output Voltage Measurement Techniques

Taking voltage measurements around drives equipment requires the right equipment and a safe approach. You are working with high voltages and high-frequency switching waveforms that are not pure sinusoids. Digital voltmeters will not usually produce reliable readings for these waveforms. And, it is usually risky to connect high voltage signals to oscilloscopes. The inverter output semiconductors have some leakage, and no-load measurements produce misleading results. So, we highly recommend using the following circuits to measure voltage for performing the equipment inspections.

Voltage measurement *with load*

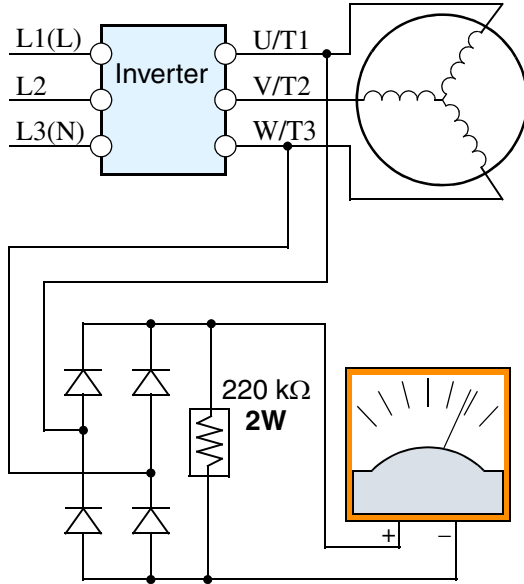

V Class	Diode Bridge	Voltmeter
200V Class	600V 0.01A min.	300V range
400V Class	100V 0.1A min.	600V range

Voltage measurement *without load*

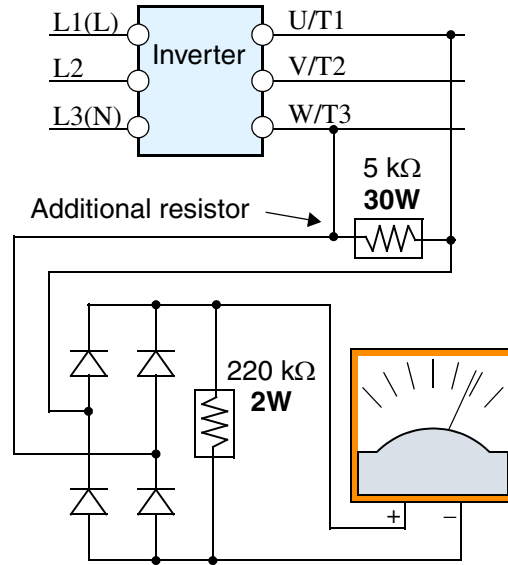

V Class	Diode Bridge	Voltmeter
200V Class	600V 0.01A min.	300V range
400V Class	100V 0.1A min.	600V range



**HIGH VOLTAGE:** Be careful not to touch wiring or connector terminals when working with the inverters and taking measurements. Be sure to place the measurement circuitry components above in an insulated housing before using them.

### IGBT Test Method

The following procedure will check the inverter transistors (IGBTs) and diodes:

1. Disconnect input power to terminals [R, S, and T] and motor terminals [U, V, and W].
2. Disconnect any wires from terminals [+] and [RB] for regenerative braking.
3. Use a Digital Volt Meter (DVM) and set it for 1Ω resistance range. You can check the status of the charging state of terminals [R, S, T, U, V, W, RB, +, and -] of the inverter and the probe of the DVM by measuring the charging state.

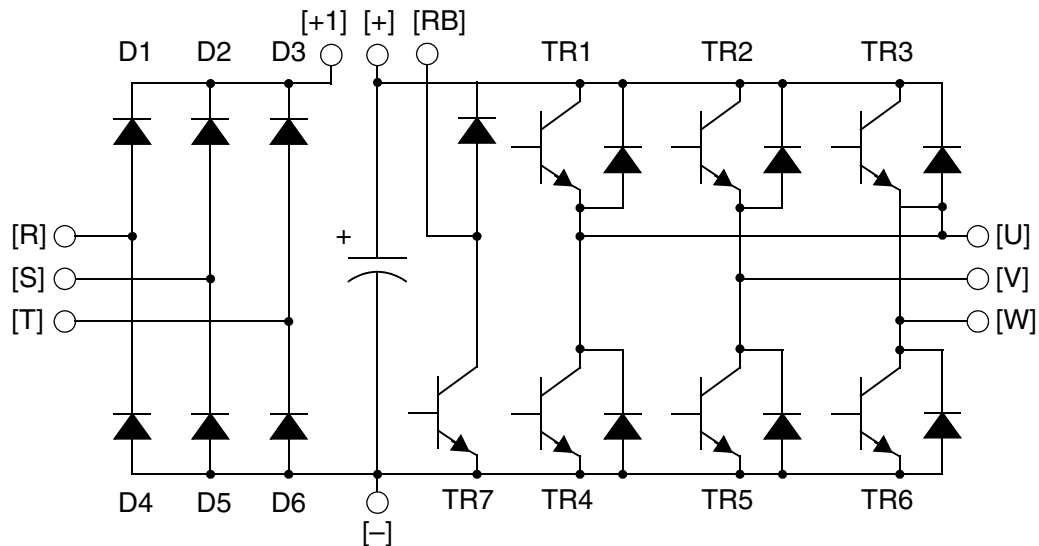

**Table Legend** – Almost infinite resistance:  $\cong \infty \Omega$  Almost zero resistance:  $\cong 0 \Omega$

Part	DVM		Measured Value	Part	DVM		Measured Value	Part	DVM		Measured Value	
	+	-			+	-			+	-		
D1	[R]	+1	$\cong \infty \Omega$	D5	[S]	[N]	$\cong 0 \Omega$	TR4	[U]	[-]	$\cong 0 \Omega$	
	+1	[R]	$\cong 0 \Omega$		[N]	[S]	$\cong \infty \Omega$		[-]	[U]	$\cong \infty \Omega$	
D2	[S]	+1	$\cong \infty \Omega$	D6	[T]	[N]	$\cong 0 \Omega$	TR5	[V]	[-]	$\cong 0 \Omega$	
	+1	[S]	$\cong 0 \Omega$		[N]	[T]	$\cong \infty \Omega$		[-]	[V]	$\cong \infty \Omega$	
D3	[T]	+1	$\cong \infty \Omega$	TR1	[U]	[+]	$\cong \infty \Omega$	TR6	[W]	[-]	$\cong 0 \Omega$	
	+1	[T]	$\cong 0 \Omega$		[+]	[U]	$\cong 0 \Omega$		[-]	[W]	$\cong \infty \Omega$	
D4	[R]	[N]	$\cong 0 \Omega$	TR2	[V]	[+]	$\cong \infty \Omega$	TR7	[RB]	[+]	$\cong 0 \Omega$	
	[N]	[R]	$\cong \infty \Omega$		[+]	[V]	$\cong 0 \Omega$		[+]	[RB]	$\cong \infty \Omega$	
				TR3	[W]	[+]	$\cong \infty \Omega$			[RB]	[-]	$\cong 0 \Omega$
					[+]	[W]	$\cong 0 \Omega$			[-]	[RB]	$\cong 0 \Omega$



**NOTE:** The resistance values for the diodes or the transistors will not be exactly the same, but they will be close. If you find a significance difference, a problem may exist.



**NOTE:** Before measuring the voltage between [+] and [-] with the DC current range, confirm that the smoothing capacitor is discharged fully, then execute the tests.

## Warranty

### Warranty Terms

The warranty period under normal installation and handling conditions shall be two (2) years from the date of manufacture (“DATE” on product nameplate), or one (1) year from the date of installation, whichever occurs first. The warranty shall cover the repair or replacement, at Hitachi's sole discretion, of ONLY the inverter that was installed.

1. Service in the following cases, even within the warranty period, shall be charged to the purchaser:
  - a. Malfunction or damage caused by mis-operation or modification or improper repair
  - b. Malfunction or damage caused by a drop after purchase and transportation
  - c. Malfunction or damage caused by fire, earthquake, flood, lightning, abnormal input voltage, contamination, or other natural disasters
2. When service is required for the product at your work site, all expenses associated with field repair shall be charged to the purchaser.
3. Always keep this manual handy; please do not lose it. Please contact your Hitachi distributor to purchase replacement or additional manuals.