

# RHINO Installation Instructions for PSB24-240 Power Supply



READ INSTRUCTIONS BEFORE INSTALLING OR OPERATING THIS DEVICE. KEEP FOR FUTURE REFERENCE.

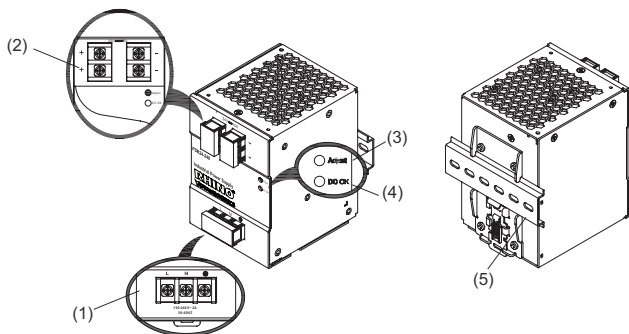

Figure 1

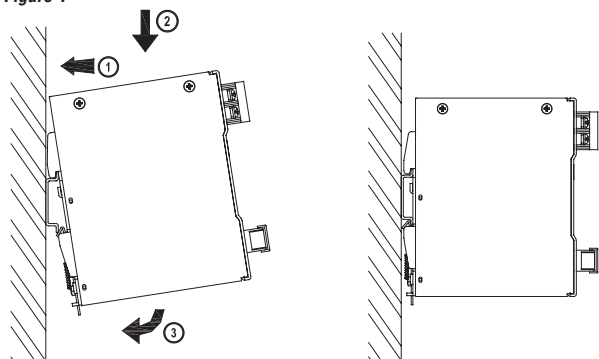

Figure 2

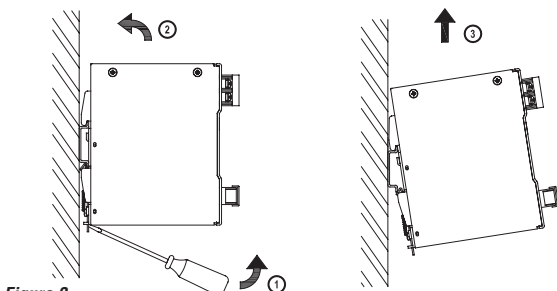

Figure 3



Figure 4

AutomationDirect P/N BM-00120 can be used.

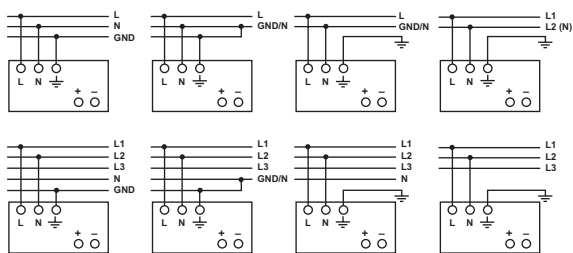

Figure 5

Power Derating Curve for PSU

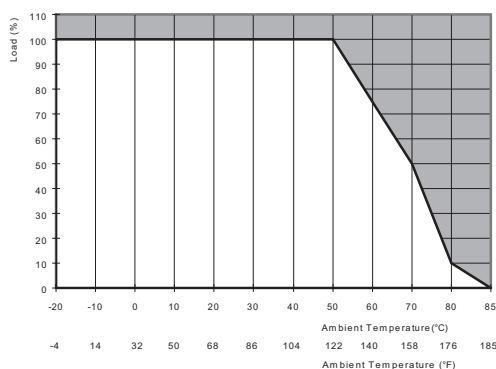

Figure 6

## 1. Safety instructions

- Switch main power off and wait 5 minutes before making any connection or disconnection on the device. Danger of serious injury or property damage!
- To guarantee sufficient convection cooling, please keep a distance of 50 mm [1.97 in] above and below the device as well as a lateral distance of 20 mm [0.79 in] to other units.
- Please note, that the enclosure of the device can become very hot depending on the ambient temperature and load of the power supply. Risk of burns!
- Only plug in and unplug connectors when power is turned off!
- Do not introduce any objects into the unit!
- Dangerous voltage present for at least 5 minutes after disconnecting all sources of power.
- To protect against access to live parts the power supply unit (PSU) must be installed in a protective enclosure.

## 2. Device description (Fig. 1)

- (1) Input terminal block connector
- (2) Output terminal block connector
- (3) DC voltage adjustment potentiometer
- (4) DC OK control LED (green)
- (5) 35mm DIN rail mounting (DIN rail sold separately)

## 3. Mounting (Fig. 2)

The power supply unit can be mounted on 35 mm DIN rails in accordance with EN60715. The device should be installed with input terminal blocks on the bottom.

Each device is delivered ready to install.

Snap on the DIN rail as shown in Fig. 2:

1. Tilt the unit slightly upwards and put it onto the DIN rail.
2. Push downwards until stopped.
3. Press against the bottom front side for locking.
4. Shake the unit slightly to ensure that it is secured.

## 4. Dismounting (Fig. 3)

To uninstall, pull or slide down the latch as shown in Fig. 3. Then, slide the PSU in the opposite direction, release the latch and pull out the PSU from the rail.

## 5. Connection

The terminal block connectors allow easy and fast wiring. A plastic cover provides the necessary isolation of the electric connection.

You can use flexible (stranded wire) or solid wire with cross section 0.32-2.1 mm<sup>2</sup> (AWG 22-14) and torque of 0.78-0.98Nm (6.94-8.68lb in). To secure reliable and shock proof connections, the stripping length should be 7 mm [0.28 in].

In accordance to EN 60950 / UL 60950, flexible wire require ferrules.

Use appropriate copper wire that is designed to sustain operating temperature of at least 75°C [167°F] or more to fulfill UL requirements.

For stranded wires it is recommended to use suitable lug (ADC P/N BM-00120) to crimp wires (see Fig. 4).

### 5.1. Input connection (Fig. 1, Fig. 5)

Use L, N and GND connections of input terminal connector (see Fig. 1 (1)) to establish the 100-240 VAC connection.

For 3-phase systems just use two phases for the connection to L and N. Need to connect GND and provide an isolation facility for all poles. The unit is protected with internal fuse (not replaceable) at L pin and it has been tested and approved on 20A (UL) and 16A (IEC) branch circuits without additional protection device. An external protection device is only required if the supplying branch has an ampacity greater than above. Thus, if an external protective device is necessary, or, utilized, a minimum value of 16A C-characteristic breaker should be used.



The internal fuse must not be replaced by the user. In case of internal defect, the unit must be discarded or returned if still under warranty

### 5.2. Output connection (Fig. 1 (2))

Use the "+" and "-" screw connections to establish the 24 VDC connection. The output provides 24 VDC. The output voltage can be adjusted from 22 to 28 VDC on the potentiometer.

The green LED DC OK displays correct function of the output (Fig. 1 (4)).

The device has a short circuit and overload protection and an overvoltage protection limited to 35 VDC.

### 5.3. Output characteristic curve

The device functions normal under operating line and load conditions. In the event of a short circuit or over load the output voltage and current collapses (IO/L or IS/C is > Isurge (150%)). The secondary voltage is reduced and bounces until short circuit or overload on the secondary side has been removed.

### 5.4. Thermal behavior (Fig. 6)

In the case of ambient temperatures above +50°C [122°F], the output capacity has to be reduced as shown in Figure 6. If the output capacity is not reduced when T<sub>Amb</sub> > 50°C [122°F] device will switch into thermal protection mode. The device will cycle output on and off to maintain internal power dissipation and will recover when ambient temperature is lowered or load is reduced as far as necessary to keep device in a normal operating mode.

FOR TECHNICAL ASSISTANCE CALL 770-844-4200

# Technical Data For PSB24-240

<b>Input (AC)</b>	
Nominal input voltage	100-240VAC
Voltage range	85-264VAC (DC input range 120-375 VDC)
Frequency	47-63Hz (0 Hz @ DC input)
Nominal current	2.9A @ 115VAC, 1.5A @ 230VAC
Inrush current limitation. I <sub>2t</sub> (+25 °C [77°F]) typ.	<40A @ 115VAC, <100A @ 230VAC
Mains buffering at nominal load (typ.)	> 20ms @ 115VAC & 230VAC
Turn-on time	< 1 sec.
Internal fuse	T 6.3 AH / 250 V (non-replaceable)
Leakage current	< 3.5 mA
<b>Output (DC)</b>	
Nominal output voltage / Adjustment range	24VDC ± 2 % / 22-28 VDC (≤240W)
Output power	240W
Nominal current	10 A
Derating above +50 °C [122°F]	2.5 % / °C. (>70°C [158°F] 4 % / °C.)
Startup with capacitive loads	Max. 10,000 µF
Max. power dissipation idling / nominal load approx.	42.5W
Efficiency (at 400 VAC and nominal values)	> 84% typical
Residual ripple/ peak switching (20 MHz) (at nominal values)	< 50 mV / < 240 mVpp
Parallel operation	With decoupling diode
<b>General Data</b>	
Type of housing	Aluminum (Al5052)
Signals	Green LED DC OK
MTBF	> 300,000 hrs.
Dimensions (L x W x H)	121 mm x 85 mm x 118.2 mm [4.76 in x 3.35 in x 4.65 in]
Weight	1.04 kg [2.29 lb]
Connection method	Screw connection
Wire size / torque	0.32-2.1 mm <sup>2</sup> (AWG 22-14) / 0.78-0.98Nm (6.94-8.68lb in)
Stripping length	7 mm [0.28 in] or use suitable lug to crimp
Ambient Operating temperature	-20°C to +75°C (> 50°C [122°F] derating) [-4°F to 167°F]
Storage temperature	-25°C to +85°C [-13°F to 185°F]
Humidity at +25°C [77°F], no condensation	<95 % RH
Shock	30g half sine, 3 times per direction, 6 directions, per IEC60068-2-27
Vibration (Non-operating)	10 to 150Hz, 5 g, 90 min. each axis per IEC60068-2-6
Pollution degree	2
Climatic class	3K3 according to EN 60721
<b>Certification and Standards</b>	
Electrical equipments of machines	IEC60204-1 (over voltage category III)
Electronic equipment for use in electrical power installations	EN 50178 / IEC62103
Safety entry low voltage	PELV (EN 60204), SELV (EN 60950)
Electrical safety (of information technology equipment)	UL/C-UL recognized to UL60950-1, CSA C22.2 No.60950-1, CB scheme to IEC60950-1
Industrial control equipment	UL listed to UL508, CSA to CSA C22.2 No.107.1-01
Protection against electric shock	DIN 57100-410
CE	In conformance with EMC directive 2014/30/EU and low voltage directive 2014/35/EU
EMC for ITE	EN55032, EN61000-3-2, EN61000-3-3, EN55024
EMC for industrial	EN55011
Limitation of mains harmonic currents	EN61000-3-2
RoHS	Yes
    	
<b>Safety and Protection</b>	
Transient surge voltage protection	VARISTOR
Current limitation at short-circuits approx.	I <sub>surge</sub> = 150 % of P <sub>0max</sub> typically
Surge voltage protection against internal surge voltages	Yes
Isolation voltage::	
Input/output (type test/routine test)	4 kVAC / 3 kVAC
Input/GND (type test/routine test)	1.5 kVAC / 1.5 kVAC
Output/GND (type test/routine test)	1.5 kVAC / 500 VAC
Protection degree	IPX0
Safety class	Class I with GND connection