

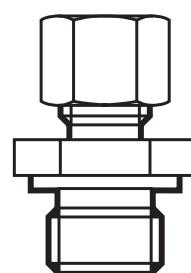

Installation Instructions
Compression fitting

CF10-50N
CF06-25N

704493 / 00 10 / 2008



- ▶ Insert the fitting (C) into the process connection and tighten.
- ▶ Use an appropriate seal if required for the application.

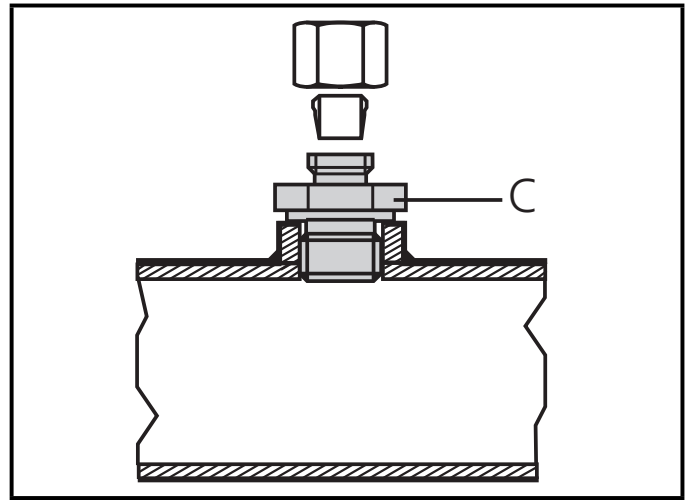

- ▶ Grease all parts of the adapter: coupling nut (A), ferrule (B), thread and cone of the fitting (C).

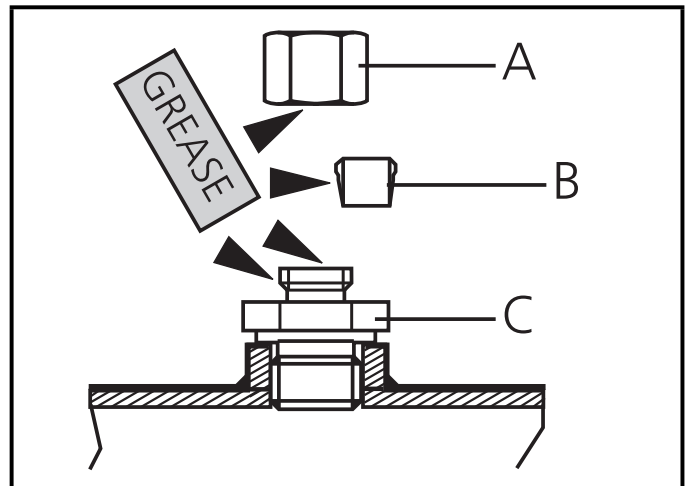

- ▶ Position the ferrule.
- NOTE: tapered end into the cone.

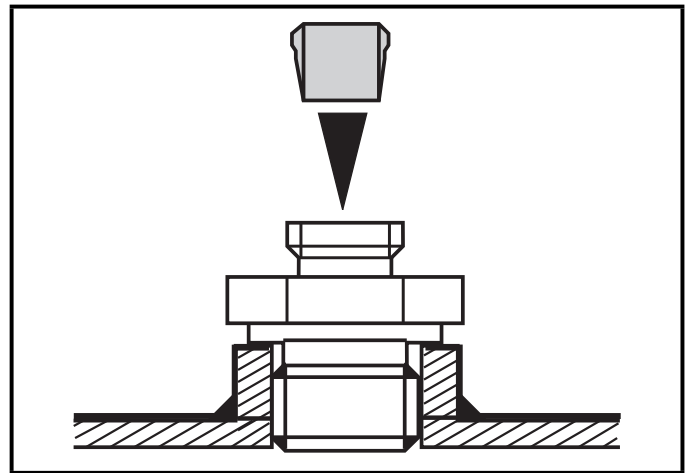

- ▶ Attach the coupling nut and insert the sensor (D).

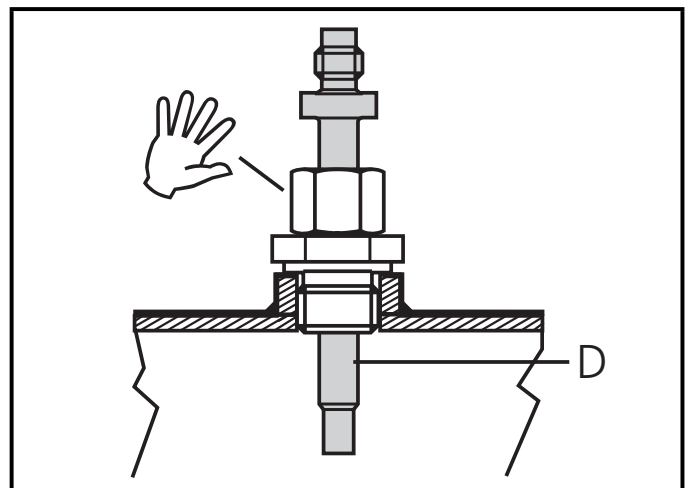

- ▶ Tighten the coupling nut manually and mark its position with a line (E).

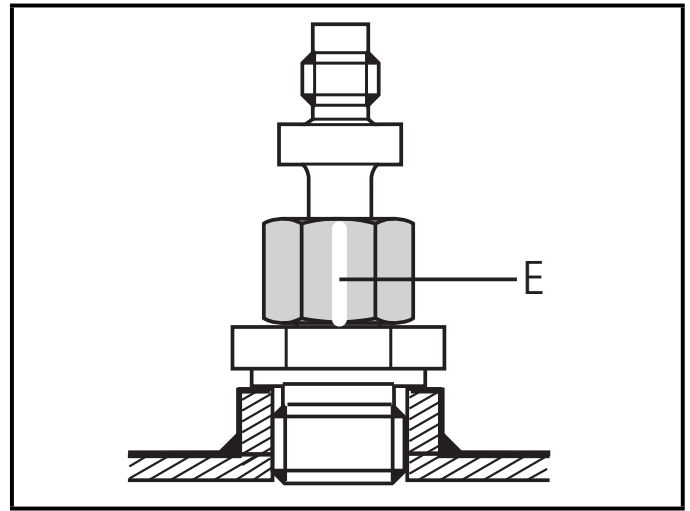

- ▶ Adjust the sensor to the required installation depth.
- ▶ Hold it and tighten the coupling nut a maximum of 2 full turns.

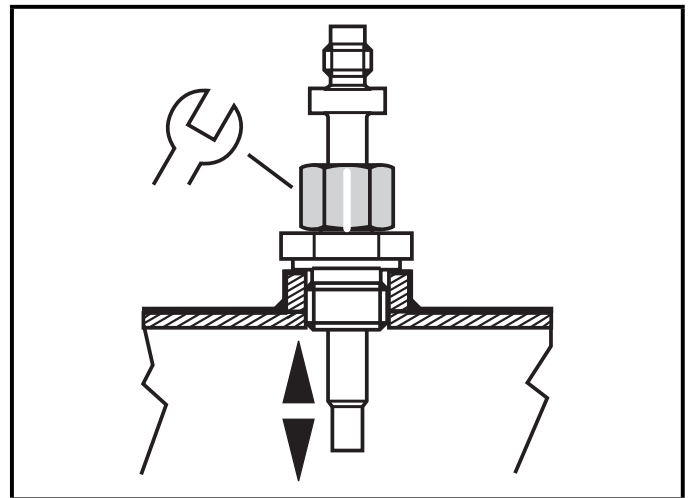

Repeated mounting

You can remove the sensor e.g. to clean the tip. Then insert the sensor again and tighten the coupling nut being careful not to apply too much force.