



**KILLARK**<sup>®</sup>

**KILLARK**

A Division of HUBBELL INCORPORATED (Delaware)  
3940 Martin Luther King Drive  
St. Louis, Missouri 63113 USA

# INSTALLATION, OPERATION & MAINTENANCE DATA SHEET

## G021 SINGLE PUSHBUTTON OPERATORS

FOR CLASS I, GROUPS C & D, CLASS II, GROUPS E, F, & C, &  
CLASS III HAZARDOUS LOCATIONS

These G021 pushbutton operators are designed for enclosures which meet the requirements of Article 500 of the National Electrical Code, and are to be mounted in enclosures with walls up to 1/2" thick.

### DIRECTIONS FOR INSTALLATION

**Be sure to turn OFF the supplying circuit, before beginning installation.**

**(1)** Using the installation drawings below as a guide, drill and tap a 3/4—14 NPSM—2B hole in the enclosure cover. The hole must be located so that a flat area is available to tighten the locknut on the inside of the cover, and enough room is allowed for mounting the nameplate on the outside. In addition, the inside cover surface must be perpendicular to the threaded hole. For Group C & D locations, a minimum of 5 full threads engagement is required. For proper electrical clearance, these devices should be mounted on 2-1/2" centers, and 1-3/4" from any vertical wall. Minimum electrical clearance between live parts of opposite polarity is 3/16"; live parts to ground, 1/4"

**(2)** Remove the cap and thread the remainder of the assembly through the hole from the inside until the threaded body protrudes approximately 1/4" on the face of the cover.

**(3)** Orient the assembly as desired, and tighten the locknut to secure it. (The assembly may be staked in place, if desired.)

**(4)** Position the nameplate on the cover and install the cap to hold it. Secure the cap with the set screw.

**(5)** Wire the system, secure the enclosure, and turn ON the supplying circuit to test the system.

**NOTE: All installations must comply with applicable local and/or National Electrical Code.**

**REMEMBER TO SAVE ONE OF THESE SHEETS FOR MAINTENANCE PERSONNEL.**

### INSTALLATION DRAWINGS

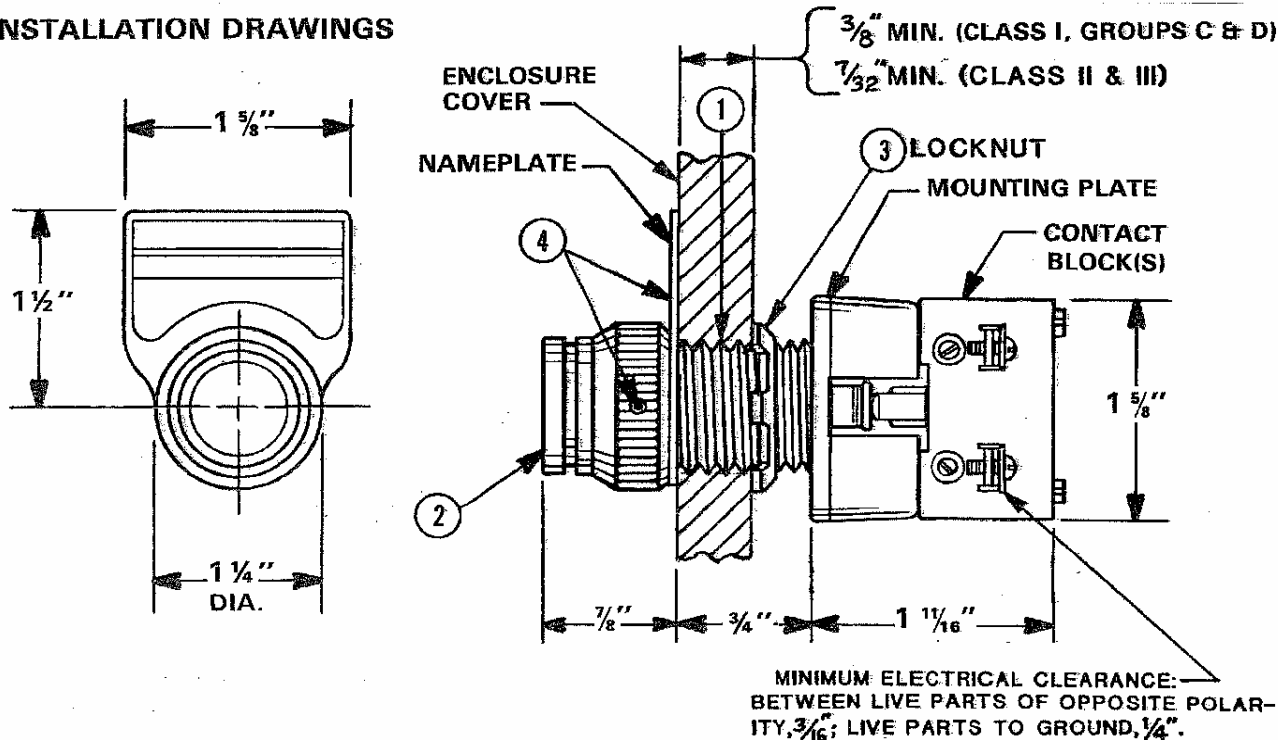

SEE REVERSE SIDE FOR OPERATIONAL AND MAINTENANCE DATA.

## OPERATIONAL DATA

The contact blocks used on these operators are electrical arcing devices. Therefore, the enclosure in which they are installed must be provided with external seals, as required by NEC articles, 501-2 & 502-5. In addition, the enclosure must be marked with a cautionary statement such as "Caution: Disconnect this device from the supplying circuit before entering. Keep assembly tight while circuits are alive." This statement must be permanently visible after the enclosure has been installed.

## MAINTENANCE DATA

"GO" Series Pushbutton Operators should be periodically checked for damage and proper operation. **WARNING:** The surface between the operator body and pushbutton shaft is a flame path. And part numbers. If play develops between these parts, both the shaft and the body must be replaced at once. ▲ Refer to the Assembly Drawing below and to the Killark catalog for specific replacement parts and part numbers.

### ASSEMBLY DRAWING

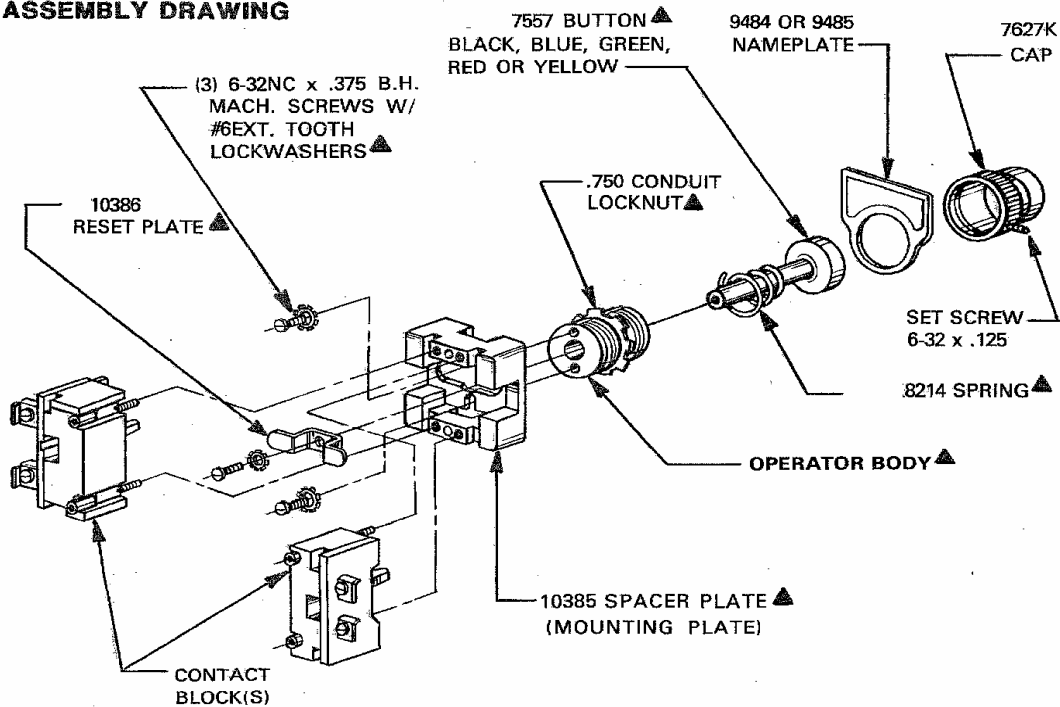

▲ NOT SOLD AS A SEPARATE ITEM.

**Technical information, advice and recommendations contained in these documents is based upon information that Killark believes to be reliable. All the information and advice contained in these documents is intended only for use by persons having been trained and possessing the requisite skill and know-how and to be used by such persons only at their own discretion and risk. The nature of these instructions is informative only and does not cover all of the details, variations or combinations in which this equipment may be used; its storage, delivery, installation, check-out, safe operation and maintenance. Since conditions of use of the product are outside of the care, custody and control of Killark, the purchaser should determine the suitability of the product for his intended use, and assumes all risk and liability whatsoever in connection therewith.**

MAINTENANCE MANAGER: Please record the following information for your records.

COMPLETE CATALOG NO. \_\_\_\_\_  
(As shown on carton)

DATE OF INSTALLATION \_\_\_\_\_