

EUROPEAN UNION DIRECTIVES (CE)



APPENDIX



In This Appendix...

European Union (EU) Directives.....	I-2
Basic EMC Installation Guidelines	I-6

European Union (EU) Directives



NOTE: *The information contained in this section is intended as a guideline and is based on our interpretation of the various standards and requirements. Since the actual standards are issued by other parties, and in some cases governmental agencies, the requirements can change over time without advance warning or notice. Changes or additions to the standards can possibly invalidate any part of the information provided in this section.*

This area of certification and approval is absolutely vital to anyone who wants to do business in Europe. One of the key tasks that faced the EU member countries and the European Economic Area (EEA) was the requirement to bring several similar yet distinct standards together into one common standard for all members. The primary purpose of a single standard was to make it easier to sell and transport goods between the various countries and to maintain a safe working and living environment. The Directives that resulted from this merging of standards are now legal requirements for doing business in Europe. Products that meet these Directives are required to have a CE mark to signify compliance.

Member Countries

As of January 1, 2015, the members of the EU are Austria, Belgium, Bulgaria, Croatia, Republic of Cyprus, Czech Republic, Denmark, Estonia, Finland, France, Germany, Greece, Hungary, Ireland, Italy, Latvia, Lithuania, Luxembourg, Malta, Netherlands, Poland, Portugal, Romania, Slovakia, Slovenia, Spain, Sweden, and United Kingdom. Iceland, Liechtenstein, and Norway together with the EU members make up the European Economic Area (EEA) and all are covered by the Directives.

Applicable Directives

There are several Directives that apply to our products. Directives may be amended, or added, as required.

- Electromagnetic Compatibility (EMC) Directive — this Directive attempts to ensure that devices, equipment, and systems have the ability to function satisfactorily in an electromagnetic environment without introducing intolerable electromagnetic disturbance to anything in that environment.
- Machinery Safety Directive — this Directive covers the safety aspects of the equipment, installation, etc. There are several areas involved, including testing standards covering both electrical noise immunity and noise generation.
- Low Voltage Directive (LVD) — this Directive is also safety related and covers electrical equipment that has voltage ranges of 50–1000VAC and/or 75–1500VDC.
- Battery Directive — this Directive covers the production, recycling, and disposal of batteries.

Compliance



NOTE: As of July 22, 2017 ROHS has been added as an additional requirement for CE Compliance per Directive 2011/65/EU. All products bearing the CE mark must be ROHS compliant.

Certain standards within each Directive already require mandatory compliance. The EMC Directive, which has gained the most attention, became mandatory as of January 1, 1996. The Low Voltage Directive became mandatory as of January 1, 1997.

Ultimately, we are all responsible for our various pieces of the puzzle. As manufacturers, we must test our products and document any test results and/or installation procedures that are necessary to comply with the Directives. As an end user, you are responsible for installing these products in a manner which will ensure compliance with the applicable standards is maintained. You are also responsible for testing any combinations of products that may (or may not) comply with the Directives when used together. The end user of the products must comply with any Directives that may cover maintenance, disposal, etc. of equipment or various components. Although we strive to provide the best assistance available, it is impossible for us to test all possible configurations of our products with respect to any specific Directive. Because of this, it is ultimately your responsibility to ensure that your machinery (as a whole) complies with these Directives and to keep up with applicable Directives and/or practices that are required for compliance.

As of January 1, 1999, the DL05, DL06, DL205, DL305, and DL405 PLC systems (except for the D2-262) manufactured by Koyo Electronics Industries, FACTS Engineering or HOST Engineering, when properly installed and used, conform to the Electromagnetic Compatibility (EMC), Low Voltage Directive, and Machinery Directive requirements of the following standards.

- **EMC Directive Standards Relevant to PLCs:**

EN50081-1 Generic emission standard for residential, commercial, and light industry

EN50081-2 Generic emission standard for industrial environment

EN50082-1 Generic immunity standard for residential, commercial, and light industry

EN50082-2 Generic immunity standard for industrial environment

- **Low Voltage Directive Standards Applicable to PLCs**

EN61010-1 Safety requirements for electrical equipment for measurement, control, and laboratory use.

- **Product Specific Standard for PLCs**

EN61131-2 Programmable controllers, equipment requirements and tests. This standard replaces the above generic standards for immunity and safety. However, the generic emissions standards must still be used in conjunction with the following standards:

EN 61000-3-2 Harmonics

EN 61000-3-2 Fluctuations

WARNING: Electrostatic Discharge (ESD)

We recommend that all personnel take necessary precautions to avoid the risk of transferring static charges within the control cabinet and provide clear warnings and instructions on the cabinet exterior. Such precautions may include the use of earth straps, grounding mats and similar static-control devices, or the powering off of the equipment inside the enclosure before the door is opened.



Appendix I: European Union Directives (CE)



WARNING: Radio Interference (RFI)

This is a class A product. In a domestic environment this product may cause radio interference in which case the user may be required to take adequate preventative measures.

With respect to the D2-262:

The following are product specific standard for CPUs and covers the low voltage and EMC directives as required for European CE certification. This standard has many tests together with test procedures and limits, but also references the below standards for some tests as they apply to the D2-262, manufactured by Koyo Electronics Industries.

General Safety

- External switches, circuit breaker or external fusing are required for these devices.
- The switch or circuit breaker should be mounted near the programmable controller equipment.

As of this printing AutomationDirect is in the process of changing their testing procedures from the generic standards to the product specific standards.

IEC 60068	IEC 60417	IEC 60664	IEC 60695	IEC 60707	IEC 60947	IEC 60950	IEC 61000	IEC 61010
-2-1:1990 Part 2 Test A	All Parts	-1:1992 Part 1	-2-1 (all sheets) Part 2	:1999	-5-1:1997 Part 5-1	-1:2001 Part 1	-4-2:1995 Part 4-2	-1:2001 Part 1
-2-2:1974 Part 2 Test B		-3:1992			-7-1:2002 Part 7-1		-4-3:2002 Part 4-3	
-2-6:1995 Part 2: Test Fc							-4-4:1995	
-2-6:1995 Part 2: Test Fc							-4-5:1995 Part 4-5	
-2-14:1984 Part 2 Test N							-4-6:1996 Part 4-6	
-2-27:1987 Part 2 Test Ea							-4-8:1993 Part 4-8	
-2-30:1980 Part 2 Test Db							-4-12:1995 Part 4-12	
-2-31:1969 Part 2 Test Ec								
-2-32:1975 Part 2 Test Ed								

For undated references, the latest edition of the referenced document (including any amendments) applies.

Other Sources of Information

Although the EMC Directive gets the most attention, other basic Directives such as the Machinery Directive and the Low Voltage Directive, also place restrictions on the control panel builder.

Because of these additional requirements it is recommended that the following publications be purchased and used as guidelines:

- BSI publication BS TH 42073: November 2000 – covers the safety and electrical aspects of the Machinery Directive
- EN 60204–1:2016 – Safety of Machinery; General electrical requirements for machinery, including Low Voltage and EMC considerations
- IEC 61000–5–2: EMC earthing and cabling requirements
- IEC 61000–5–1: EMC general considerations

It may be possible for you to obtain this information locally; however, the official source of applicable Directives and related standards is:

- The Office for Official Publications of the European Communities L–2985 Luxembourg.

The quickest contact is via the World Wide Web at http://publications.europa.eu/index_en.htm

Other sources are:

British Standards Institution – Sales Department

Linford Wood

Milton Keynes

MK14 6LE

United Kingdom;

The quickest contact is via the World Wide Web at <http://www.bsi.org.uk>

Or a commercial provider of Standards at www.ihs.com

Basic EMC Installation Guidelines

Enclosures

The simplest way to meet the safety requirements of the Machinery and Low Voltage Directives is to house all control equipment in an industry standard lockable steel enclosure. Normally this has an added benefit because it will also help ensure that the EMC characteristics are well within the requirements of the EMC Directive. Although the RF emissions from the PLC equipment, when measured in the open air, are well below the EMC Directive limits, certain configurations can increase emission levels. Enclosure penetrations, for the passage of cables or to mount operator interfaces, will often increase emissions.

AC Mains Filters

DL05, DL06, and DL205 AC powered base power supplies require extra mains filtering to comply with the EMC Directive on conducted RF emissions. All PLC equipment has been tested with filters from Schaffner, which reduce emissions levels when the filters are properly grounded (earth ground). A filter with a current rating suitable to supply all PLC power supplies and AC input modules should be selected. We suggest the FN2010 for DL05/DL06/DL205 systems.

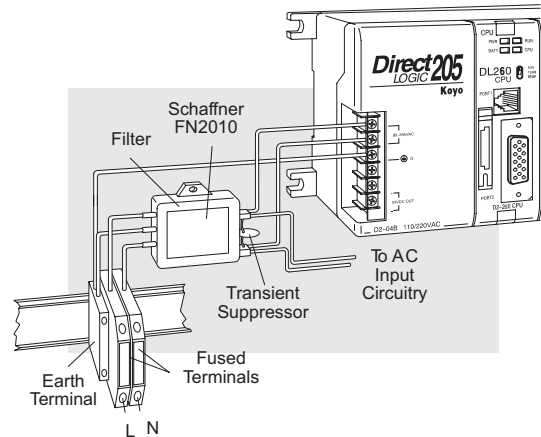

NOTE: Very few mains filters can reduce problem emissions to negligible levels. In some cases, filters may increase conducted emissions if not properly matched to the problem emissions.

Suppression and Fusing

In order to comply with the fire risk requirements of the Low Voltage and Machinery Directive electrical standards (EN 61010–1 and EN 60204–1), by limiting the power into “unlimited” mains circuits with power leads reversed, it is necessary to fuse both AC and DC supply inputs. You should also install a transient voltage suppressor across the power input connections of the PLC. Choose a suppressor such as a metal oxide varistor with a rating of 275VAC working voltage for 230V nominal supplies (150VAC working voltage for 115V supplies) and high energy capacity (e.g., 140 joules).

Transient suppressors must be protected by fuses, and the capacity of the transient suppressor must be greater than the blow characteristics of the fuses or circuit breakers to avoid a fire risk. A recommended AC supply input arrangement for Koyo PLCs is to use twin 3 amp TT fused terminals with fuse blown indication, such as DINnectors DN–F10L terminals, or twin circuit breakers, wired to a Schaffner FN2010 filter or equivalent, with high energy transient suppressor soldered directly across the output terminals of the filter. PLC system inputs should also be protected from voltage impulses by deriving their power from the same fused, filtered, and surge-suppressed supply.

Internal Enclosure Grounding

A heavy-duty star earth terminal block should be provided in every cubicle for the connection of all earth ground straps, protective earth ground connections, mains filter earth ground wires, and mechanical assembly earth ground connections. This should be installed to comply with safety and EMC requirements, local standards, and the requirements found in IEC 1000–5–2. The Machinery Directive also requires that the common terminals of PLC input modules, and common supply side of loads driven from PLC output modules, should be connected to the protective earth ground terminal.

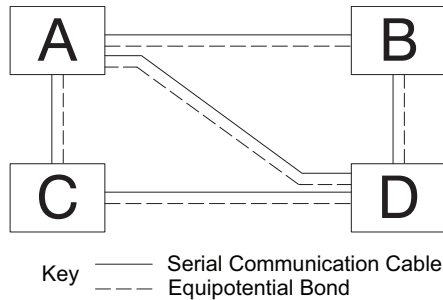

Equipotential Grounding

Adequate site earth grounding must be provided for equipment containing modern electronic circuitry. The use of isolated earth electrodes for electronic systems is forbidden in some countries. Make sure you check any requirements for your particular destination. IEC 1000–5–2 covers equipotential bonding of earth grids adequately, but special attention should be given to apparatus and control cubicles that contain I/O devices, remote I/O racks, or have inter-system communications with the primary PLC system enclosure. An equipotential bond wire must be provided alongside all serial communications cables, and to any separate items of the plant which contain I/O devices connected to the PLC. The diagram above shows an example of four physical locations connected by a communications cable.

Communications and Shielded Cables

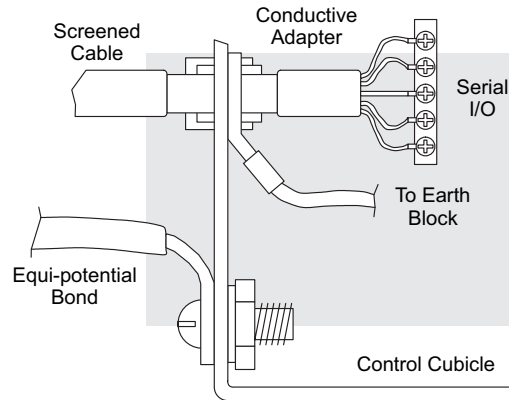

Good quality 24AWG minimum twisted-pair shielded cables, with overall foil and braid shields, are recommended for analog cabling and communications cabling outside of the PLC enclosure. To date, it has been a common practice to only provide an earth ground for one end of the cable shield in order to minimize the risk of noise caused by earth ground loop currents between apparatus. The procedure of only grounding one end, which primarily originated as a result of trying to reduce hum in audio systems, is no longer applicable to the complex industrial environment. Shielded cables are also efficient emitters of RF noise from the PLC system, and can interact in a parasitic manner in networks and between multiple sources of interference.

The recommendation is to use shielded cables as electrostatic “pipes” between apparatus and systems, and to run heavy gauge equipotential bond wires alongside all shielded cables. When a shielded cable runs through the metallic wall of an enclosure or machine, it is recommended in IEC 1000–5–2 that the shield should be connected over its full perimeter to the wall, preferably using a conducting adapter, and not via a pigtail wire connection to an earth ground bolt. Shields must be connected to every enclosure wall or machine cover that they pass through.

Analog and RS232 Cables

Providing an earth ground for both ends of the shield for analog circuits provides the perfect electrical environment for the twisted pair cable as the loop consists of signal and return, in a perfectly balanced circuit arrangement, with connection to the common of the input circuitry made at the module terminals. RS232 cables are handled in the same way.

Multi-drop Cables

RS422 twin twisted pair and RS485 single twisted pair cables also require a 0V link, which has often been provided in the past by the cable shield. It is now recommended that you use triple twisted pair cabling for RS422 links, and twin twisted pair cable for RS485 links. This is because the extra pair can be used as the 0V inter-system link. With loop DC power supplies earth grounded in both systems, earth loops are created in this manner via the inter-system 0v link. The installation guides encourage earth loops, which are maintained at a low impedance by using heavy equipotential bond wires. To account for non-European installations using single-end earth grounds, and sites with far from ideal earth ground characteristics, we recommend the addition of 100 ohm resistors at each 0V link connection in network and communications cables.

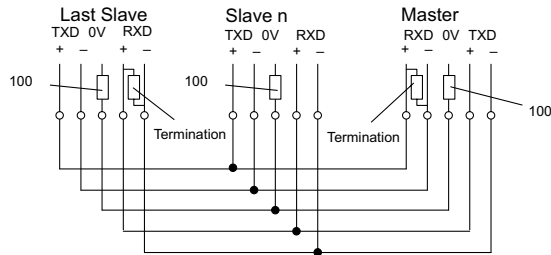

Shielded Cables within Enclosures

When you run cables between PLC items within an enclosure that also contains susceptible electronic equipment from other manufacturers, remember that these cables may be a source of RF emissions. There are ways to minimize this risk. Standard data cables connecting PLCs and/or operator interfaces should be routed well away from other equipment and its associated cabling. You can make special serial cables where the cable shield is connected to the enclosure's earth ground at both ends, the same way that external cables are connected.

Analog Modules and RF Interference

All Automationdirect products are tested to withstand field strength levels up to 10V/m, which is the maximum required by the relevant EU standards. While all products pass this test, analog modules will typically exhibit deviations of their readings. This is quite normal; however, systems designers should be aware of this and plan accordingly.

When assembling a control system using analog modules, these issues must be adhered to and should be integrated into the system design. This is the responsibility of the system builder/commissioner.

Network Isolation

For safety reasons, it is a specific requirement of the Machinery Directive that a keyswitch must be provided that isolates any network input signal during maintenance, so that remote commands cannot be received that could result in the operation of the machinery.

The FA-ISOCAN does not have a keyswitch! Use a keylock and switch on your enclosure which, when open, removes power from the FA-ISOCAN. To avoid the introduction of noise into the system, any keyswitch assembly should be housed in its own earth grounded steel box and the integrity of the shielded cable must be maintained.

Appendix I: European Union Directives (CE)

Again, for further information on EU directives, we recommend that you get a copy of our EU Installation Manual (DA-EU-M). Also, if you are connected to the World Wide Web, you can check the EU Commission's official site at: http://ec.europa.eu/index_en.htm.

DC Powered Versions

Due to slightly higher emissions radiated by the DC powered versions of the DL205, and the differing emissions performance for different DC supply voltages, the following stipulations must be met:

- The PLC must be housed within a metallic enclosure with a minimum number of orifices.
- I/O and communications cabling exiting the cabinet must be contained within metallic conduit/trunking.

Items Specific to the DL205

- The rating between all circuits in this product are rated as basic insulation only, as appropriate for single fault conditions.
- There is no isolation offered between the PLC and the analog inputs of this product.
- It is the responsibility of the system designer to earth one side of all control and power circuits, and to earth the braid of screened cables.
- This equipment must be properly installed while adhering to the guidelines of the installation manual DA-EU-M (available for download at AutomationDirect Technical Support Manuals), and the installation standards IEC 1000-5-1, IEC 1000-5-2 and IEC 1131-4.
- It is a requirement that all PLC equipment must be housed in a protective steel enclosure, which limits access to operators by a lock and power breaker. If operators or untrained personnel require access, the equipment must be installed inside an internal cover or secondary enclosure. A warning label must be used on the front door of the installation cabinet as follows:

Warning: Exposed terminals and hazardous voltages inside.

- It should be noted that the safety requirements of the machinery directive standard EN60204-1 state that all equipment power circuits must be wired through isolation transformers or isolating power supplies, and that one side of all AC or DC control circuits must be earthed.
- Both power input connections to the PLC must be separately fused using 3 amp T-type anti-surge fuses, and a transient suppressor fitted to limit supply overvoltages.
- If the user is made aware through the documentation that the equipment, when used in a manner not specified by the manufacturer, the protection provided by the equipment may be impaired.