



DL205 Analog I/O Manual

Manual Number: D2-ANLG-M

~ WARNING ~

Thank you for purchasing automation equipment from **AutomationDirect.com**[®], doing business as, **AutomationDirect**. We want your new automation equipment to operate safely. Anyone who installs or uses this equipment should read this publication (and any other relevant publications) before installing or operating the equipment.

To minimize the risk of potential safety problems, you should follow all applicable local and national codes that regulate the installation and operation of your equipment. These codes vary from area to area and usually change with time. It is your responsibility to determine which codes should be followed, and to verify that the equipment, installation, and operation is in compliance with the latest revision of these codes.

At a minimum, you should follow all applicable sections of the National Fire Code, National Electrical Code, and the codes of the National Electrical Manufacturer's Association (NEMA). There may be local regulatory or government offices that can also help determine which codes and standards are necessary for safe installation and operation.

Equipment damage or serious injury to personnel can result from the failure to follow all applicable codes and standards. We do not guarantee the products described in this publication are suitable for your particular application, nor do we assume any responsibility for your product design, installation, or operation.

Our products are not fault-tolerant and are not designed, manufactured or intended for use or resale as on-line control equipment in hazardous environments requiring fail-safe performance, such as in the operation of nuclear facilities, aircraft navigation or communication systems, air traffic control, direct life support machines, or weapons systems, in which the failure of the product could lead directly to death, personal injury, or severe physical or environmental damage ("High Risk Activities"). **AutomationDirect** specifically disclaims any expressed or implied warranty of fitness for High Risk Activities.

For additional warranty and safety information, see the Terms and Conditions section of our catalog. If you have any questions concerning the installation or operation of this equipment, or if you need additional information, please call us at 770-844-4200.

This publication is based on information that was available at the time it was printed. At **AutomationDirect** we constantly strive to improve our products and services, so we reserve the right to make changes to the products and/or publications at any time without notice and without any obligation. This publication may also discuss features that may not be available in certain revisions of the product.

Trademarks

This publication may contain references to products produced and/or offered by other companies. The product and company names may be trademarked and are the sole property of their respective owners. **AutomationDirect** disclaims any proprietary interest in the marks and names of others.

Copyright 2024, AutomationDirect.com Incorporated
All Rights Reserved

No part of this manual shall be copied, reproduced, or transmitted in any way without the prior, written consent of **AutomationDirect.com Incorporated**. **AutomationDirect** retains the exclusive rights to all information included in this document.

⚡ ADVERTENCIA ⚡

Gracias por comprar equipo de automatización de **Automationdirect.com**[®]. Deseamos que su nuevo equipo de automatización opere de manera segura. Cualquier persona que instale o use este equipo debe leer esta publicación (y cualquier otra publicación pertinente) antes de instalar u operar el equipo.

Para reducir al mínimo el riesgo debido a problemas de seguridad, debe seguir todos los códigos de seguridad locales o nacionales aplicables que regulan la instalación y operación de su equipo. Estos códigos varían de área en área y usualmente cambian con el tiempo. Es su responsabilidad determinar cuales códigos deben ser seguidos y verificar que el equipo, instalación y operación estén en cumplimiento con la revisión más reciente de estos códigos.

Como mínimo, debe seguir las secciones aplicables del Código Nacional de Incendio, Código Nacional Eléctrico, y los códigos de (NEMA) la Asociación Nacional de Fabricantes Eléctricos de USA. Puede haber oficinas de normas locales o del gobierno que pueden ayudar a determinar cuales códigos y normas son necesarios para una instalación y operación segura.

Si no se siguen todos los códigos y normas aplicables, puede resultar en daños al equipo o lesiones serias a personas. No garantizamos los productos descritos en esta publicación para ser adecuados para su aplicación en particular, ni asumimos ninguna responsabilidad por el diseño de su producto, la instalación u operación.

Nuestros productos no son tolerantes a fallas y no han sido diseñados, fabricados o intencionados para uso o reventa como equipo de control en línea en ambientes peligrosos que requieren una ejecución sin fallas, tales como operación en instalaciones nucleares, sistemas de navegación aérea, o de comunicación, control de tráfico aéreo, máquinas de soporte de vida o sistemas de armamentos en las cuales la falla del producto puede resultar directamente en muerte, heridas personales, o daños físicos o ambientales severos (“Actividades de Alto Riesgo”). **Automationdirect.com** específicamente rechaza cualquier garantía ya sea expresada o implicada para actividades de alto riesgo.

Para información adicional acerca de garantía e información de seguridad, vea la sección de Términos y Condiciones de nuestro catálogo. Si tiene alguna pregunta sobre instalación u operación de este equipo, o si necesita información adicional, por favor llámenos al número 770-844-4200 en Estados Unidos.

Esta publicación está basada en la información disponible al momento de impresión. En **Automationdirect.com** nos esforzamos constantemente para mejorar nuestros productos y servicios, así que nos reservamos el derecho de hacer cambios al producto y/o a las publicaciones en cualquier momento sin notificación y sin ninguna obligación. Esta publicación también puede discutir características que no estén disponibles en ciertas revisiones del producto.

Marcas Registradas

Esta publicación puede contener referencias a productos producidos y/u ofrecidos por otras compañías. Los nombres de las compañías y productos pueden tener marcas registradas y son propiedad única de sus respectivos dueños. **Automationdirect.com**, renuncia cualquier interés propietario en las marcas y nombres de otros.

PROPIEDAD LITERARIA 2024, AUTOMATIONDIRECT.COM[®] INCORPORATED
Todos los derechos reservados

No se permite copiar, reproducir, o transmitir de ninguna forma ninguna parte de este manual sin previo consentimiento por escrito de **Automationdirect.com[®] Incorporated**. **Automationdirect.com** retiene los derechos exclusivos a toda la información incluida en este documento. Los usuarios de este equipo pueden copiar este documento solamente para instalar, configurar y mantener el equipo correspondiente. También las instituciones de enseñanza pueden usar este manual para propósitos educativos.

~ AVERTISSEMENT ~

Nous vous remercions d'avoir acheté l'équipement d'automatisation de **Automationdirect.com^{MC}**, en faisant des affaires comme, **AutomationDirect**. Nous tenons à ce que votre nouvel équipement d'automatisation fonctionne en toute sécurité. Toute personne qui installe ou utilise cet équipement doit lire la présente publication (et toutes les autres publications pertinentes) avant de l'installer ou de l'utiliser.

Afin de réduire au minimum le risque d'éventuels problèmes de sécurité, vous devez respecter tous les codes locaux et nationaux applicables régissant l'installation et le fonctionnement de votre équipement. Ces codes diffèrent d'une région à l'autre et, habituellement, évoluent au fil du temps. Il vous incombe de déterminer les codes à respecter et de vous assurer que l'équipement, l'installation et le fonctionnement sont conformes aux exigences de la version la plus récente de ces codes.

Vous devez, à tout le moins, respecter toutes les sections applicables du Code national de prévention des incendies, du Code national de l'électricité et des codes de la National Electrical Manufacturer's Association (NEMA). Des organismes de réglementation ou des services gouvernementaux locaux peuvent également vous aider à déterminer les codes ainsi que les normes à respecter pour assurer une installation et un fonctionnement sûrs.

L'omission de respecter la totalité des codes et des normes applicables peut entraîner des dommages à l'équipement ou causer de graves blessures au personnel. Nous ne garantissons pas que les produits décrits dans cette publication conviennent à votre application particulière et nous n'assumons aucune responsabilité à l'égard de la conception, de l'installation ou du fonctionnement de votre produit.

Nos produits ne sont pas insensibles aux défaillances et ne sont ni conçus ni fabriqués pour l'utilisation ou la revente en tant qu'équipement de commande en ligne dans des environnements dangereux nécessitant une sécurité absolue, par exemple, l'exploitation d'installations nucléaires, les systèmes de navigation aérienne ou de communication, le contrôle de la circulation aérienne, les équipements de survie ou les systèmes d'armes, pour lesquels la défaillance du produit peut provoquer la mort, des blessures corporelles ou de graves dommages matériels ou environnementaux («activités à risque élevé»). La société **AutomationDirect** nie toute garantie expresse ou implicite d'aptitude à l'emploi en ce qui a trait aux activités à risque élevé.

Pour des renseignements additionnels touchant la garantie et la sécurité, veuillez consulter la section Modalités et conditions de notre documentation. Si vous avez des questions au sujet de l'installation ou du fonctionnement de cet équipement, ou encore si vous avez besoin de renseignements supplémentaires, n'hésitez pas à nous téléphoner au 770-844-4200.

Cette publication s'appuie sur l'information qui était disponible au moment de l'impression. À la société **AutomationDirect**, nous nous efforçons constamment d'améliorer nos produits et services. C'est pourquoi nous nous réservons le droit d'apporter des modifications aux produits ou aux publications en tout temps, sans préavis ni quelque obligation que ce soit. La présente publication peut aussi porter sur des caractéristiques susceptibles de ne pas être offertes dans certaines versions révisées du produit.

Marques de commerce

La présente publication peut contenir des références à des produits fabriqués ou offerts par d'autres entreprises. Les désignations des produits et des entreprises peuvent être des marques de commerce et appartiennent exclusivement à leurs propriétaires respectifs. **AutomationDirect** nie tout intérêt dans les autres marques et désignations.

Copyright 2024, Automationdirect.com Incorporated
Tous droits réservés

Nulle partie de ce manuel ne doit être copiée, reproduite ou transmise de quelque façon que ce soit sans le consentement préalable écrit de la société **Automationdirect.com Incorporated**. **AutomationDirect** conserve les droits exclusifs à l'égard de tous les renseignements contenus dans le présent document.

DL205 ANALOG I/O MODULES



Please include the Manual Number and Issue, both shown below, when communicating with Technical Support regarding this publication.

Manual Number: D2-ANLG-M
Issue: 7th Edition Rev. H
Issue Date: 11/24

Publication History		
Issue	Date	Description of Changes
1st Edition	1/94	Original Edition
2nd Edition	4/95	New Edition
3rd Edition	9/97	Added new modules
4th Edition	4/99	Added new modules
5th Edition	5/00	Added new modules
6th Edition	4/02	Added new modules
Rev. A	6/02	Added D2-250-1 and D2-260 CPUs and removed references to D2-250 CPU. (Note: D2-250 has same functionality as a D2-250-1 except for local expansion capability).
Rev. B	8/02	Minor corrections
7th Edition	8/05	Added new F2-8AD4DA chapters 15 and 16 and miscellaneous minor changes.
Rev A	11/06	Added information about changes to F2-04THM jumper link locations in chapter 7.
Rev. B	4/10	Added information about jumper link locations and some input specification changes on F2-04AD-1, F2-04AD-2, F2-08AD-1, F2-08AD-2, and F2-02DAS-2 modules. Also added RWide input range to F2-04THM specification table.
Rev. C	9/17	Minor changes - changed to download version only
Rev. D	12/17	Made correction to wiring diagram in Chapter 11
Rev. E	12/18	Added D2-262 CPU and revised complete manual.
Rev. F	5/19	Chapter 16 - revised ladder examples 1, 2, and 3; updated V-memory location tables.
Rev. G	6/20	Chapter 8 & 9 - revised external power supply value requirements in data tables.
Rev. H	11/24	Removed Type 1 fonts, added hyperlinks to footers.



TABLE OF CONTENTS

Warning

Table of Contents

Chapter 1 - Getting Started

Introduction	1-2
--------------------	-----

Chapter 2 - F2-04AD-1, F2-04AD-1L 4-Channel Analog Current Input

F2-04AD-1	2-2
Analog Input Configuration Requirements	2-4
Special Placement Requirements (D2-230 and Remote I/O Bases)	2-4
Selecting the Number of Channels	2-6
Wiring Guidelines	2-7
User Power Supply Requirements	2-7
Current Loop Transmitter Impedance	2-8
Wiring Diagram	2-9
Channel Scanning Sequence (Multiplexing) for a D2-230 CPU	2-10
Channel Scanning Sequence (Pointer method) for D2-240, D2-250-1, D2-260 or D2-262 CPU	2-11
Analog Module Updates	2-11
Understanding the Input Assignments	2-12
Analog Data Bits	2-12
Active Channel Indicator Inputs	2-13
Module Diagnostic Inputs	2-13
Module Resolution	2-13
Reading Values: Pointer Method and Multiplexing	2-14
Pointer Method for D2-240, D2-250-1, D2-260 and D2-262	2-14

Table of Contents

Reading Values (Multiplexing) for D2-230, D2-240, D2-250-1, D2-260 and D2-262 CPUs	2-16
Single Channel Selected	2-16
Analog Power Failure Detection	2-17
Scaling the Input Data.....	2-17
The Conversion Program.....	2-18
Analog and Digital Value Conversions.....	2-18
Filtering Input Noise for D2-250-1, D2-260 and D2-262 CPUs Only	2-19

Chapter 3 - F2-04AD-2, F2-04AD-2L 4-Channel Analog Voltage Input

Module Specifications	3-2
F2-04AD-2	3-2
F2-04AD-2L is Obsolete.....	3-2
Analog Input Configuration Requirements.....	3-2
Special Placement Requirements (D2-230 and Remote I/O Bases).....	3-4
Setting the Module Jumpers	3-5
Selecting the Number of Channels	3-5
Selecting the Input Signal Range.....	3-6
Connecting the Field Wiring	3-7
Wiring Guidelines	3-7
User Power Supply Requirements.....	3-7
Custom Input Ranges	3-8
Wiring Diagram	3-9
Module Operation	3-10
Channel Scanning Sequence (Multiplexing) for a D2-230 CPU.....	3-10
Channel Scanning Sequence (Pointer method) for D2-240, D2-250-1, D2-260 or D2-262 CPUs	3-11
Analog Module Updates	3-11
Understanding Input Assignments	3-12
Analog Data Bits	3-12
Active Channel Indicator Inputs	3-13
Module Diagnostic and Sign Inputs	3-13
Module Resolution.....	3-14

Writing the Control Program..... 3-15

- Reading Values: Pointer Method and Multiplexing 3-15
- Pointer Method for the D2-240, D2-250-1, D2-260 and D2-262 CPUs 3-15
- Using Bipolar Ranges (Pointer Method) for
D2-240, D2-250-1, D2-260 and D2-262 CPUs..... 3-17
- Reading Values (Multiplexing) for
D2-230, D2-240, D2-250-1, D2-260 and D2-262 CPUs 3-18
- Single Channel Selected 3-19
- Using Bipolar Ranges (Multiplexing) 3-19
- Using 2’s Complement (Multiplexing) for
D2-230, D2-240, D2-250-1, D2-260 and D2-262 CPUs 3-20
- Analog Power Failure Detection 3-21
- Scaling the Input Data..... 3-21
- The Conversion Program..... 3-22
- Analog and Digital Value Conversions..... 3-22
- Filtering Input Noise for D2-250-1, D2-260 and D2-262 CPUs..... 3-23

Chapter 4 - F2-08AD-1, 8-Channel Analog Current Input

- Module Specifications 4-2
- Setting the Module Jumpers 4-5
- Connecting the Field Wiring..... 4-6
- Module Operation 4-9
- Writing the Control Program..... 4-13

Chapter 5 - F2-08AD-2 8-Channel Analog Voltage Input

- Module Specifications 5-2
 - Firmware Requirements: 5-2
 - Analog Input Configuration Requirements 5-2
 - Special Placement Requirements (D2-230 and Remote I/O Bases) 5-4
- Setting the Module Jumpers 5-5
 - Selecting the Number of Channels 5-5
 - Selecting the Input Voltage..... 5-6
- Connecting the Field Wiring..... 5-7

Table of Contents

Wiring Guidelines	5-7
User Power Supply Requirements.....	5-7
Wiring Diagram	5-8
Module Operation	5-9
Channel Scanning Sequence (Multiplexing) for a D2-230 CPU.....	5-9
Channel Scanning Sequence (Pointer method) for D2-240, D2-250-1, D2-260 or D2-262 CPUs.....	5-10
Analog Module Updates	5-10
Understanding the Input Assignments.....	5-11
Analog Data Bits	5-11
Active Channel Indicator Inputs	5-12
Module Resolution.....	5-13
Writing the Control Program.....	5-14
Reading Values: Pointer Method and Multiplexing	5-14
Pointer Method for D2-240, D2-250-1, D2-260 and D2-262 CPUs.....	5-14
Using Bipolar Ranges (Pointer Method) for D2-240, D2-250-1, D2-260 and D2-262 CPUs.....	5-16
Reading Values (Multiplexing) for D2-230, D2-240, D2-250-1, D2-260 and D2-262 CPUs.....	5-17
Single Channel Selected	5-18
Using Bipolar Ranges (Multiplexing)	5-18
Using 2's Complement (Multiplexing) for D2-230, D2-240, D2-250-1, D2-260 and D2-262 CPUs.....	5-19
Analog Power Failure Detection	5-20
Scaling the Input Data.....	5-20
The Conversion Program.....	5-21
Analog and Digital Value Conversions.....	5-21
Filtering Input Noise for D2-250-1, D2-260 and D2-262 CPUs.....	5-22

Chapter 6 - F2-04RTD 4-Channel RTD Input

Module Calibration	6-2
RTD Input Configuration Requirements	6-2
Input Specifications	6-3
Special Placement Requirements (D2-230 and Remote I/O Bases).....	6-4
Jumper Locations.....	6-5
Selecting the Number of Channels	6-5
Setting Input Type.....	6-5

Selecting the Conversion Units.....	6-6
Wiring Guidelines.....	6-7
RTD - Resistance Temperature Detector	6-7
Ambient Variations in Temperature	6-8
Wiring Diagram.....	6-8
Channel Scanning Sequence (Multiplexing) for a D2-230 CPU.....	6-9
Channel Scanning Sequence (Pointer Method) for D2-240, D2-250-1, D2-260 or D2-262 CPUs	6-10
Analog Module Updates.....	6-10
Reading Values: Pointer Method and Multiplexing.....	6-11
Pointer Method for the D2-240, D2-250-1, D2-260 or D2-262 CPUs.....	6-11
Negative Temperature Readings with Magnitude Plus Sign (Pointer Method) for the D2-240, D2-250-1, D2-260 or D2-262 CPUs.....	6-13
Magnitude Plus Sign (Binary)	6-14
Magnitude Plus Sign (BCD).....	6-14
Negative Temperatures 2's Complement (Binary/Pointer Method) for the D2-240, D2-250-1, D2-260 or D2-262 CPUs	6-15
Understanding the Input Assignments (Multiplexing Ladder Only).....	6-15
Analog Data Bits.....	6-16
Active Channel Bits.....	6-16
Broken Transmitter Bits (Multiplexing Ladder Methods).....	6-16
Reading Magnitude Plus Sign Values (Multiplexing).....	6-17
Reading 2's Compliment Values (Multiplexing)	6-18
Scaling the Input Data.....	6-18
Filtering Input Noise (D2-250-1, D2-260 and D2-262 CPUs Only).....	6-19

Chapter 7 - F2-04THM 4-Channel Thermocouple Input

Module Specifications	7-2
Module Calibration.....	7-4
Thermocouple Input Configuration Requirements.....	7-4
Special Placement Requirements (D2-230 and Remote I/O Bases).....	7-5
Setting the Module Jumpers	7-6
Jumper Locations.....	7-6
Calibrate Enable.....	7-6
Selecting the Number of Channels.....	7-7
Setting Input Type.....	7-7

Table of Contents

Selecting the Conversion Units.....	7-8
Thermocouple Conversion Units.....	7-8
Voltage Conversion Units.....	7-8
Connecting the Field Wiring.....	7-9
Wiring Guidelines.....	7-9
User Power Supply Requirements.....	7-9
Thermocouples.....	7-10
Ambient Variations in Temperature.....	7-10
Wiring Diagrams.....	7-11
Module Operation.....	7-13
Channel Scanning Sequence (Multiplexing) for a D2-230 CPU.....	7-13
Channel Scanning Sequence (Pointer Method) for D2-240, D2-250-1, D2-260 and D2-262 CPUs.....	7-14
Analog Module Updates.....	7-14
Writing the Control Program.....	7-15
Reading Values Pointer Method and Multiplexing.....	7-15
Pointer Method for the D2-240, D2-250-1, D2-260 and D2-262 CPUs.....	7-15
Negative Temperature Readings with Magnitude Plus Sign (Pointer Method) for D2-240, D2-250-1, D2-260 and D2-262 CPUs.....	7-17
Magnitude Plus Sign (Binary).....	7-17
Magnitude Plus Sign (BCD).....	7-18
Negative Temperatures 2's Complement (Binary/Pointer Method) for D2-240, D2-250-1, D2-260 and D2-262 CPUs.....	7-19
Understanding the Input Assignments (Multiplexing Ladder Only).....	7-19
Analog Data Bits.....	7-20
Active Channel Bits.....	7-20
Broken Transmitter Bits (Pointer and Multiplexing Ladder Methods).....	7-20
Reading Magnitude Plus Sign Values (Multiplexing).....	7-21
Reading 2's Compliment Values (Multiplexing).....	7-22
Scaling the Input Data.....	7-22
Module Resolution 16-Bit (Unipolar Voltage Input).....	7-23
Module Resolution 15-Bit Plus Sign(Bipolar Voltage Input).....	7-23
Analog and Digital Value Conversions.....	7-24
Filtering Input Noise (D2-250-1, D2-260 and D2-262 CPUs Only).....	7-25

Chapter 8 - F2-02DA-1,F2-02DA-1L 2-Channel Analog Current Output

Analog Output Configuration Requirements.....	8-2
Special Placement Requirements (D2-230 and Remote I/O Bases).....	8-4
Wiring Guidelines.....	8-5
User Power Supply Requirements.....	8-5
Wiring Diagram.....	8-6
Load Range.....	8-6
Channel Scanning Sequence (Multiplexing) for a D2-230 CPU.....	8-7
Channel Scanning Sequence (Pointer Method) for D2-240, D2-250-1, D2-260 and D2-262 CPUs	8-8
Understanding the Output Assignments.....	8-9
Channel Select Outputs.....	8-9
Analog Data Bits.....	8-10
Module Resolution.....	8-10
Writing Values: Pointer Method and Multiplexing.....	8-11
Pointer Method for the D2-240, D2-250-1, D2-260 and D2-262 CPUs.....	8-11
Writing Data (Multiplexing).....	8-13
Write Data to One Channel.....	8-14
Write Data to Both Channels.....	8-14
Calculating the Digital Value.....	8-15
Analog and Digital Value Conversions.....	8-15
The Conversion Program.....	8-16

Chapter 9 - F2-02DA-2, F2-02DA-2L, 2-Channel Analog Voltage Output

Module Specifications	9-2
Analog Output Configuration Requirements.....	9-2
Special Placement Requirements (D2-230 and Remote I/O Bases).....	9-4
Setting the Module Jumpers	9-5
Voltage Range and Output Combinations.....	9-6
Connecting and Disconnecting the Field Wiring	9-8
Wiring Guidelines.....	9-8
User Power Supply Requirements.....	9-8
Wiring Diagram.....	9-9
Module Operation	9-10
Channel Scanning Sequence (Multiplexing) for a D2-230 CPU.....	9-10

Table of Contents

Channel Scanning Sequence (Pointer Method) for D2-240, D2-250-1, D2-260 and D2-262 CPUs	9-11
Understanding the Output Assignments.....	9-12
Channel Select Outputs	9-12
Analog Data Bits	9-13
Signal Sign Output.....	9-13
Bipolar Output Data	9-13
Module Resolution.....	9-14
Writing the Control Program.....	9-15
Calculating the Digital Value.....	9-15
The Conversion Program.....	9-16
Negative Values with Bipolar Range.....	9-17
Writing Values: Pointer Method and Multiplexing.....	9-18
Writing Values (Pointer Method) for D2-240, D2-250-1, D2-260 and D2-262 CPUs.....	9-18
Writing Data (Multiplexing).....	9-20
Write Data to One Channel.....	9-22
Write Data to Both Channels.....	9-22
Analog and Digital Value Conversions.....	9-23

Chapter 10 - F2-08DA-1, 8-Channel Analog Current Output

Module Specifications	10-2
Firmware Requirements:.....	10-2
Analog Output Configuration Requirements.....	10-2
Special Placement Requirements (D2-230 and Remote I/O Bases)	10-4
Connecting and Disconnecting the Field Wiring	10-5
Wiring Guidelines	10-5
User Power Supply Requirements.....	10-5
Wiring Diagram.....	10-6
Load Range	10-6
Module Operation.....	10-7
Channel Scanning Sequence (Multiplexing) for a D2-230 CPU.....	10-7
Channel Scanning Sequence (Pointer Method) for D2-240, D2-250-1, D2-260 and D2-262 CPUs	10-8
Understanding the Output Assignments.....	10-8
Channel Select Outputs	10-9

Analog Data Bits	10-10
Output Enable.....	10-10
Module Resolution.....	10-10
Writing the Control Program.....	10-11
Calculating the Digital Value.....	10-11
The Conversion Program.....	10-11
Writing Values: Pointer Method and Multiplexing.....	10-12
Pointer Method for the D2-240, D2-250-1, D2-260 and D2-262 CPUs.....	10-12
Writing Data (Multiplexing Example)	10-14
Write Data (Multiplexing Example) Continued.....	10-15
Write Data to One Channel.....	10-16
Analog and Digital Value Conversions.....	10-16

Chapter 11 - F2-08DA-2, 8-Channel Analog Voltage Output

Module Specifications	11-2
Firmware Requirements:	11-2
Analog Output Configuration Requirements.....	11-3
Special Placement Requirements (D2-230 and Remote I/O Bases).....	11-4
Setting the Module Jumpers	11-5
Voltage Range and Output Combinations.....	11-5
Connecting the Field Wiring.....	11-6
Wiring Guidelines.....	11-6
User Power Supply Requirements.....	11-6
Wiring Diagram.....	11-7
Module Operation	11-8
Channel Update Sequence (Multiplexing) for a D2-230 CPU	11-8
Channel Update Sequence (Pointer Method) for D2-240, D2-250-1, D2-260 and D2-262 CPUs.....	11-9
Understanding the Output Assignments.....	11-10
Channel Select Outputs	11-10
Analog Data Bits	11-11
Output Enable.....	11-11
Module Resolution.....	11-11

Table of Contents

Writing the Control Program	11-12
Calculating the Digital Value.....	11-12
The Conversion Program.....	11-13
Writing Values: Pointer Method and Multiplexing.....	11-14
Pointer Method for the D2-240, D2-250-1, D2-260 and D2-262 CPUs.....	11-14
Writing Data Example (Multiplexing).....	11-16
Write Data to One Channel.....	11-18
Analog and Digital Value Conversions.....	11-18

Chapter 12 - F2-02DAS-1, 4–20 mA Isolated 2-Channel Analog Current Output

Module Specifications	12-2
Firmware Requirements:.....	12-2
Analog Output Configuration Requirements.....	12-3
Special Placement Requirements (D2-230 and Remote I/O Bases).....	12-4
Connecting the Field Wiring	12-5
Wiring Guidelines.....	12-5
Loop Power Supply Requirements.....	12-5
Wiring Diagram.....	12-6
Module Operation	12-7
Channel Update Sequence (Multiplexing) for a D2-230 CPU.....	12-7
Channel Update Sequence (Pointer Method) for D2-240, D2-250-1, D2-260 and D2-262 CPUs.....	12-8
Understanding the Output Assignments.....	12-9
Channel Select Outputs.....	12-9
Analog Data Bits.....	12-10
Module Resolution.....	12-10
Writing the Control Program	12-11
Calculating the Digital Value.....	12-11
Engineering Units Conversion.....	12-12
Writing Values: Pointer Method and Multiplexing.....	12-13
Pointer Method for D2-240, D2-250-1, D2-260 and D2-262 CPUs.....	12-13
Write Data Example (Multiplexing).....	12-15
Write Data to One Channel.....	12-16

Write the same Data to Both Channels.....12-16
 Analog and Digital Value Conversions.....12-17

Chapter 13 - F2-02DAS-2, 0-5V, 0-10V, 2-Channel Isolated Analog Output

Module Specifications13-2
 Firmware Requirements:..... 13-2
 Analog Output Configuration Requirements 13-3
 Special Placement Requirements (D2-230 and Remote I/O Bases)..... 13-4
Setting the Module Jumpers13-5
Connecting the Field Wiring..... 13-6
 Wiring Guidelines 13-6
 Transmitter Power Supply Requirements..... 13-6
 Wiring Diagram 13-7
Module Operation13-8
 Channel Update Sequence (Multiplexing) for a D2-230 CPU 13-8
 Channel Update Sequence (Pointer Method) for
 D2-240, D2-250-1, D2-260 and D2-262 CPUs 13-9
 Understanding the Output Assignments..... 13-9
 Channel Select Outputs 13-10
 Analog Data Bits..... 13-10
 Module Resolution..... 13-11
Writing the Control Program.....13-12
 Calculating the Digital Value..... 13-12
 Engineering Units Conversion..... 13-13
 Writing Values: Pointer Method and Multiplexing..... 13-14
 Pointer Method for the D2-240, D2-250-1, D2-260 and D2-262 CPUs 13-14
 Write Data Example (Multiplexing) 13-16
 Write Data to One Channel..... 13-17
 Write the same Data to Both Channels..... 13-17
 Analog and Digital Value Conversions..... 13-18

Chapter 14 - F2-4AD2DA, 4-Ch. In / 2-Ch. Out Analog Combination

Module Specifications 14-2
 Combination Analog Configuration Requirements 14-3

Table of Contents

Special Placement Requirements (D2-230 and Remote I/O Bases).....	14-4
Connecting the Field Wiring.....	14-5
Wiring Guidelines.....	14-5
Loop Power Supply Requirements.....	14-5
Current Loop Transmitter Impedance.....	14-6
Wiring Diagram.....	14-7
Module Operation.....	14-8
Input Channel Scanning Sequence (Multiplexing) for a D2-230 CPU.....	14-8
Input Channel Scanning Sequence (Pointer Method) for D2-240, D2-250-1, D2-260 and D2-262 CPUs.....	14-8
Output Channel Update Sequence (Multiplexing) for a D2-230 CPU.....	14-9
Output Channel Update Sequence (Pointer Method) for D2-240, D2-250-1, D2-260 and D2-262 CPUs.....	14-9
Understanding the I/O Assignments.....	14-10
Input Data Bits.....	14-10
Active Channel Indicator Bits.....	14-11
Diagnostic Indicator Inputs.....	14-11
Output Data Bits.....	14-11
Output Channel Selection Bits.....	14-12
Module Resolution.....	14-12
Writing the Control Program.....	14-13
Analog Input Failure Detection.....	14-13
Calculating the Digital Value.....	14-13
Scaling the Input Data.....	14-15
Read / Write Program (Pointer Method) for D2-240, D2-250-1, D2-260 and D2-262 CPUs.....	14-16
Read Input Values (Multiplexing).....	14-18
Single Input Channel Selected (Multiplexing).....	14-19
Write Output Values (Multiplexing).....	14-19
Write Data to One Channel.....	14-20
Write the same Data to Both Channels.....	14-20
Analog and Digital Value Conversions.....	14-20
Filtering Input Noise (D2-250-1, D2-260 and D2-262 CPUs Only).....	14-21

Chapter 15 - F2-8AD4DA-1, 8-Ch. In / 4-Ch. Out Analog Current Combination

Module Specifications	15-2
F2-8AD4DA-1 Requirements.....	15-2
Module Placement and Configuration Requirements.....	15-5
Connecting the Field Wiring	15-6
Wiring Guidelines.....	15-6
User Power Supply Requirements.....	15-6
Current Loop Transmitter Impedance	15-7
Wiring Diagram.....	15-8
Module Operation	15-9
Input Channel Scanning Sequence (Pointer Method).....	15-9
Output Channel Update Sequence (Pointer Method).....	15-10
Understanding the I/O Assignments.....	15-11
Input Data Bits.....	15-12
Output Data Bits.....	15-12
Special V-Memory Locations	15-13
Module Configuration Registers	15-13
Number of I/O Channels Enabled & Data Format.....	15-14
Input Selection Resolution Bits.....	15-14
Input Track and Hold Selection Bits.....	15-15
Writing the Control Program	15-16
Configuring the Module to Read/Write I/O (Pointer Method) for D2-250-1, D2-260 and D2-262.....	15-16
Module Configuration Example 1:.....	15-17
Module Configuration Example 2:.....	15-18
Module Configuration Example 3:.....	15-19
Module 12-bit Input Resolution.....	15-20
Module 14-bit Input Resolution.....	15-20
Module 16-bit Input Resolution.....	15-20
Analog and Digital Input Data Value Conversion.....	15-21
Input Value Comparisons: Analog, Digital, Engineering Units	15-21
Scaling the Input Data.....	15-22
Scaling Example	15-22

Table of Contents

Input Engineering Unit Conversion Example 1:.....	15-23
Input Engineering Unit Conversion Example 2:.....	15-23
Input Engineering Unit Conversion Example 3:.....	15-24
Input Engineering Unit Conversion Example 4:.....	15-25
Using the Input Track and Hold Feature.....	15-25
Track and Hold Example:.....	15-26
Module 16-bit Output Resolution	15-27
Digital and Analog Output Data Value Conversion.....	15-27
Output Value Comparisons: Analog, Digital, Engineering Units	15-27
Calculating the Digital Output Value.....	15-28
Calculating Output Data: Engineering Units Conversion	15-28
Output Engineering Unit Conversion / Output Data Calculation Example:.....	15-28

Chapter 16 - F2-8AD4DA-2, 8-Ch. In / 4-Ch. Out Analog Voltage Combination

Module Specifications	16-2
F2-8AD4DA-2 Hardware and Firmware Requirements.....	16-2
Module Placement and Configuration Requirements.....	16-5
Connecting the Field Wiring.....	16-6
Wiring Guidelines	16-6
User Power Supply Requirements.....	16-6
Wiring Diagram.....	16-7
Module Operation	16-8
Input Channel Scanning Sequence (Pointer Method)	16-8
Output Channel Update Sequence (Pointer Method)	16-9
Understanding the I/O Assignments.....	16-10
Input Data Bits.....	16-11
Output Data Bits	16-11
Special V-Memory Locations.....	16-12
Module Configuration Registers	16-12
Number of I/O Channels Enabled & Data Format.....	16-13
Input Selection Resolution Bits	16-13
Input and Output Range Selection Bits.....	16-14
Input Track and Hold Selection Bits.....	16-15

Writing the Control Program..... 16-16

- Configuring the Module to Read/Write I/O (Pointer Method) for
D2-250-1, D2-260 and D2-262.....16-16
- Module Configuration Example 1:.....16-17
- Module Configuration Example 2:.....16-18
- Module Configuration Example 3:.....16-19
- Module 12-bit Input Resolution.....16-20
- Module 14-bit Input Resolution.....16-20
- Module 16-bit Input Resolution.....16-20
- Analog and Digital Input Data Value Conversion.....16-21
- Scaling the Input Data.....16-22
- Scaling Example16-22
- Input Engineering Unit Conversion Example 1:.....16-23
- Input Engineering Unit Conversion Example 2:.....16-23
- Input Engineering Unit Conversion Example 3:.....16-24
- Using the Input Track and Hold Feature.....16-24
- Track and Hold Example:.....16-25
- Module 16-bit Output Resolution16-26
- Digital and Analog Output Data Value Conversion.....16-26
- Output Value Comparisons: Analog, Digital, Engineering Units16-26
- Calculating the Digital Output Value.....16-27
- Calculating Output Data: Engineering Units Conversion16-27

Appendix A - DL205 Discrete I/O Memory Map

- Input (X) / Output (Y) Bit Map.....A-2
- Control Relay Bit MapA-4
- Remote I/O Bit Map (D2-260 and D2-262 only)A-8

GETTING STARTED



CHAPTER 1

In This Chapter...

Introduction	1-2
Conventions Used.....	1-3
Physical Characteristics	1-3
Analog Input Module Terminology.....	1-4
Analog Output Module Terminology	1-5
Selecting the Appropriate Module.....	1-6
Analog Made Easy – Four Steps.....	1-9

Introduction

The Purpose of this Manual

This manual shows how to select and install analog input and analog output modules. It also shows several ways to use the analog data in a PLC program. If you understand the DL205 instruction set and system setup requirements, this manual will provide the information needed to install and use the analog modules. This manual is not intended to be a tutorial on analog signal theory, but rather a user reference manual for the DL205 Analog I/O modules.

Supplemental Manuals

A copy of the DL205 User Manual (D2-USER-M) will be helpful when working with the analog modules. The DL205 User Manual is not absolutely necessary, but it does provide detailed descriptions of the instructions used to acquire the analog data. The User Manual also provides a more thorough description of how the I/O points are assigned to the module. This is all the material necessary to quickly understand the DL205 Analog I/O modules.

Technical Support

We strive to make our manuals the best in the industry. We rely on your feedback to let us know if we are reaching our goal. If you cannot find the solution to your particular application, or, if for any reason you need technical assistance, please call us at:

770-844-4200

Our technical support group will work with you to answer your questions. They are available Monday through Friday from 9:00 A.M. to 6:00 P.M. Eastern Time. We also encourage you to visit our web site where you can find technical and non-technical information about our products and our company.

<http://www.automationdirect.com>

If you have a comment, question or suggestion about any of our products, services, or manuals, please fill out and return the Suggestions card that was included with this manual.

Conventions Used



When the “notepad” icon is in the left–hand margin, the paragraph to its immediate right will be a special note.

The word **NOTE** in boldface will mark the beginning of the text.



When the “exclamation mark” icon is in the left–hand margin, the paragraph to its immediate right will be a warning. This information could prevent injury, loss of property, or even death (in extreme cases).

The word **WARNING** in boldface will mark the beginning of the text which will also be in boldface..

Key Topics for Each Chapter

The beginning of each chapter will list the key topics that can be found in that chapter.

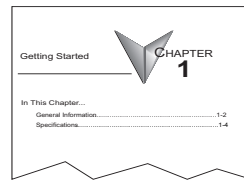

Physical Characteristics

The DL205 Analog Modules provide many features that make the modules easy to use. With the exception of the thermocouple module, the terminal blocks are removable, which makes wiring a simple task. All of the DL205 analog modules have normal screw terminal connectors. Access the module terminals by removing the front cover (not shown). To remove the front cover, press the tab on the lower front corner of the cover. For ease of removal, the terminal blocks have squeeze tabs on the top and bottom. To remove a terminal block, press the tabs and pull the terminal block away from the module.



WARNING: For some modules, field device power may still be present on the terminal block even though the PLC system is turned off. To minimize the risk of electrical shock, check all field device power before you remove the connector.

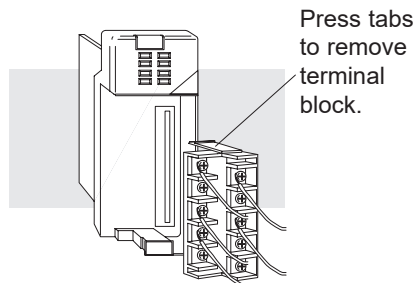

Analog Input Module Terminology

Several different terms are used throughout the rest of this manual. The terms may be helpful to make it easier to select the appropriate analog modules. Take a few minutes to review these definitions.

Channels per Module - The total number of analog signals the module receives from field devices.

Input Ranges - The minimum to maximum spans in voltage or current the module will successfully convert to digital values.

Resolution - The number of binary weighted bits available on the digital side of the module for use in converting the analog value to a digital value.

Input Type - Specifies if the module accepts single ended, or differential input signals.

Input Impedance - The resistive load of the module as seen by a voltage or current input signal.

Conversion Method - The method the module uses to convert the analog signal to a digital value.

PLC Update Rate - Speed at which the analog signals are digitized and acknowledged in the PLC.

Linearity Error - The relative accuracy of the digital representation over the entire input range.

Maximum Inaccuracy - Maximum absolute error of the digital representation of the signal over the entire input range. Factors which contribute to maximum inaccuracy are also specified separately. These factors are full-scale calibration error, offset calibration error, and accuracy vs. temperature.

Accuracy vs. Temperature - The variations in the module's conversion accuracy with temperature over the module's operating temperature range.

I/O Points Required - The number of I/O points the CPU must dedicate to the module.

External Power Source - Some modules require a separate 12VDC or 24VDC power source. The 24VDC output supply at the local base can be used as long as you do not exceed the current ratings of 300mA.

Base Power Required - The amount of base current required by the module. Use this value in your power budget calculations.

Operating Temperature - The minimum and maximum temperatures the module will operate within.

Relative Temperature - The minimum and maximum humidity the module will operate within.

Step Response - The time required for an analog input to reach 95% of its final value at the converter following a step change in the input signal level.

Analog Output Module Terminology

Channels per Module - The total number of analog signals the module sends to field devices.

Output Ranges - The minimum to maximum spans in voltage or current the module outputs, converted from digital values.

Resolution - The number of binary weighted bits available on the digital side of the module for use in converting the digital value to an analog signal.

Output Current - The maximum current the module will drive using a voltage output signal.

Output Impedance - The output impedance of the module using a voltage output signal.

Load Impedance - The minimum and maximum resistance the module can drive, specified for current and voltage output signals.

PLC Update Rate - The speed at which digital values in the PLC are converted to analog output signals.

Linearity Error - The relative accuracy of the digital representation over the entire output range.

Maximum Inaccuracy - Maximum absolute error of the digital representation of the signal over the entire output range. Factors which contribute to maximum inaccuracy are also specified separately. These factors are full-scale calibration error, offset calibration error, and accuracy vs temperature.

Accuracy vs. Temperature - The variations in the module's conversion accuracy with temperature over the module's operating temperature range.

External Power - All output modules contain circuitry which is optically isolated from PLC-side logic. That circuitry requires field-side power from a separate 24VDC power source. The 24VDC output supply at the local base can be used as long as you do not exceed the current ratings.

Base Power Required - The amount of base current required by the module. Use this value in your power budget calculations.

Operating Temperature - The minimum and maximum temperatures the module will operate within.

Relative Humidity - The range of air humidity over which the module will operate properly.

I/O Points Required - The number of I/O points the CPU must dedicate to the module.

Selecting the Appropriate Module

Wide Variety of Modules

There are a wide variety of analog I/O modules available for use with the DL205 family of automation products. These modules are well suited for monitoring and controlling various types of analog signals such as pressure, temperature, etc. No complex programming or module setup software is required. Simply install the module, add a few lines to the RLL program. That's all.

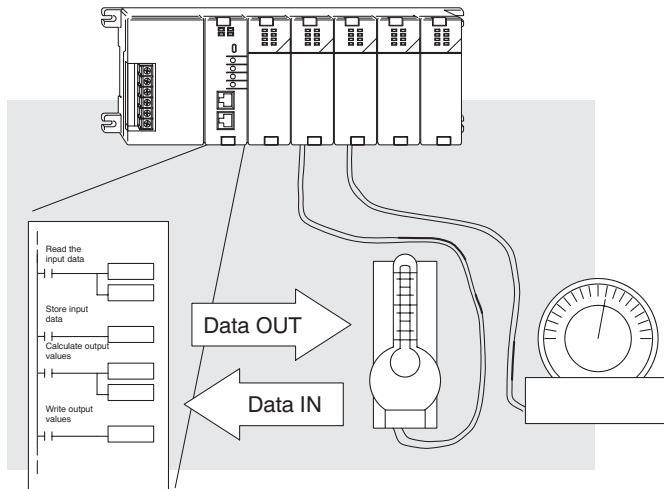

Analog input, temperature input and analog output modules are available. These modules are designed and manufactured by FACTS Engineering. FACTS has been producing feature-packed products for the DirectLOGIC families (and compatible products) for years! These modules are readily identifiable by their F2- prefix in the part number.

Diagnostic Features

The DL205 Analog Modules use an on-board microcontroller that automatically monitors module diagnostics. Missing field-side supply 24VDC voltage or a loose terminal block can be easily detected.

The following tables provide a condensed version of the information needed to select the appropriate module. The most important thing is to simply determine the number of channels required and the signal ranges that must be supported. Once the parameters have been determined, look in the specific chapter for the selected module to determine the installation and operation requirements.

Analog Input Modules				
Specification	F2-04AD-1, (L)	F2-04AD-2, (L)	F2-08AD-1	F2-08AD-2
Channels	4	4	8	8
Input Ranges	4-20 mA	0-5 V, 0-10 V, $\pm 5V$, $\pm 10V$	4-20 mA	0-5 V, 0-10 V, $\pm 5V$, $\pm 10V$
Resolution	12 bit (1 in 4096)	12 bit (1 in 4096), and 13 bit (1 in 8192)	12 bit (1 in 4096)	12 bit (1 in 4096), and 13 bit (1 in 8192)
Input Type	Single ended	Single ended	Single ended	Single ended
Maximum Inaccuracy	$\pm 0.5\%$ at 25°C (77°F), $\pm 0.65\%$ at 0°-60°C (32°-140°F)	$\pm 0.1\%$ at 25°C (77°F), $\pm 0.3\%$ at 0°-60°C (32°-140°F)	$\pm 0.1\%$ at 25°C (77°F), $\pm 0.25\%$ at 0°-60°C (32°-140°F)	$\pm 0.1\%$ at 25°C (77°F), $\pm 0.3\%$ at 0°-60°C (32°-140°F)
See Chapter...	2	3	4	5

Special Input		
Specification	F2-04RTD	F2-04THM
Input Channels	4	4
Resolution	16 bit internal	16 bit voltage ranges 24 bit internal
Input Ranges	Pt100 Ω , -200.0-850.0 °C (-328-1562 °F) Pt1000 Ω , -200.0-595.0 °C (-328-1103 °F) Pt100 Ω , -38.0-450.0 °C (-36-842 °F) Cu. 25 Ω , Cu. 10 Ω -200.0-260.0 °C (-328-500 °F)	Type J -190-760.0 °C E -210-1000.0 °C K -150-1372.0 °C R 65-1768.0 °C R Wide -0-1768.0 °C S 65-1768.0 °C T -230-400.0 °C B 529-1820.0 °C N -70-1300.0 °C C 65-2320.0 °C
Input Type	Differential	Differential
Maximum Input Inaccuracy	± 1.0 °C	± 3.0 °C Temperature $\pm 0.02\%$ Voltage
See Chapter...	6	7

Analog Output		
Specification	F2-02DA-1, (L)	F2-02DA-2, (L)
Channels	2	2
Output Ranges	4–20 mA	0–5 V, 0–10 V, ±5V, ±10V
Resolution	12 bit (1 in 4096)	12 bit (1 in 4096)
Output Type	Single ended	Single ended
See Chapter...	8	9

Analog Output		
Specification	F2-08DA-1	F2-08DA-2
Channels	8	8
Output Ranges	4–20 mA	0–5 V, 0–10 V
Resolution	12 bit (1 in 4096)	16 bit (1 in 4096)
Output Type	Single ended	Single ended, 1 common
See Chapter...	10	11

Analog Output		
Specification	F2-02DAS-1	F2-02DAS-2
Channels	2	2
Output Ranges	4–20 mA	0–5 V, 0–10 V
Resolution	16 bit (1 in 65536)	16 bit (1 in 65536)
Output Type	Current sourcing	Isolated
See Chapter...	12	13

Combination Analog			
Specification	F2-4AD2DA	F2-8AD4DA-1	F2-8AD4DA-2
Input Channels	4	8	8
Output Channels	2	4	4
Input Ranges	4–20 mA	0–20 mA	0–5 V, 0–10 V
Output Ranges	4–20 mA	4–20 mA	0–5 V, 0–10 V
Resolution	12 bit (1 in 4096)	12-bit, 14 bit or 16 bit; selectable	12-bit, 14 bit or 16 bit; selectable
Channel Isolation	Non-isolated (one common)	Isolated (one common)	Isolated (one common)
Input and Output Types	Single ended	Single ended	Single ended
Maximum Input Inaccuracy	±0.3% at 25°C (77°F), ±0.45% at 0°–60°C (32°–140°F)	±0.1% of range maximum	±0.1% of range maximum
Maximum Output Inaccuracy	±0.1% at 25°C (77°F), ±0.3% at 0°–60°C (32°–140°F)	±0.1% of range maximum	±0.1% of range maximum
See Chapter	14	15	16

Analog Made Easy – Four Steps

Once the appropriate module has been selected, use the chapter that describes that module and complete the following steps.

Step 1.

Take a moment to review the detailed specifications to be sure the module chosen will meet the application requirements.

Specification		
Channels	2	2
Output Ranges	4 – 20 mA	0 – 5V 0 – 10V –5 – +5V –10 – +10V
Resolution	12 bit (1 m 4096)	12 bit (1 m 4096)
Channel Isolation	Non-isolated	Non-isolated
Output Type	Single ended	Single ended
Maximum Inaccuracy at 25 °C (77 °F)	±0.1%	±0.2% unipolar ±0.4% bipolar
at 0° – 25°C (32° – 78°F)	±0.2%	
See Chapter	4	5

Step 2.

If applicable, set the module switches and/or jumpers to select:

- Number of channels
- The operating ranges.

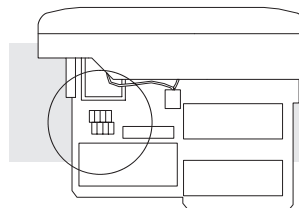

Step 3.

Connect the field wiring to the module connector.

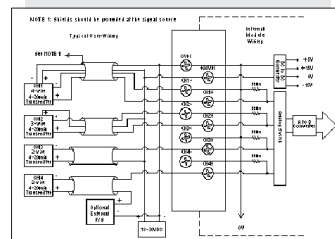

Step 4.

Review the module operating characteristics and write the control program.

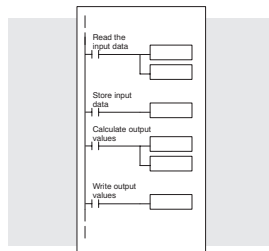

F2-04AD-1, F2-04AD-1L, 4-CHANNEL ANALOG CURRENT INPUT



In This Chapter...

Module Specifications	2-2
Setting the Module Jumpers	2-6
Connecting the Field Wiring	2-7
Module Operation	2-10
Writing the Control Program.....	2-14

Module Specifications

F2-04AD-1

The F2-04AD-1 analog Input module provides several hardware features.

- On-board 250 ohm, 1/2 Watt precision resistors provide substantial over-current-protection for 4–20mA current loops.
- Analog inputs are optically isolated from the PLC logic.
- The module has a removable terminal block so the module can be easily removed or changed without disconnecting the wiring.
- With a D2-240, D2-250-1, D2-260 or D2-262 CPU, all four channels can be read in one scan.

On-board active analog filtering and RISC-like microcontroller provide digital signal processing to maintain precision analog measurements in noisy environments.

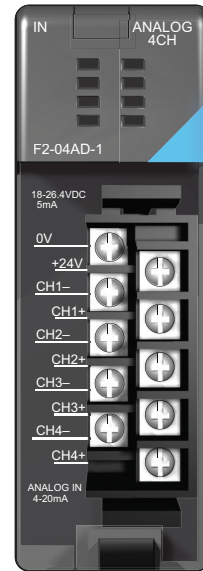

F2-04AD-1L is Obsolete



NOTE: In 2009 the F2-04AD-1L was discontinued. A re-designed F2-04AD-1 was released at the same time which can be powered by either 12VDC or 24VDC input power supplies. This new module is a direct replacement for legacy F2-04AD-1 and all F2-04AD-1L modules. The new module is a single circuit board design so the jumper link locations are different. See "Setting the Module Jumpers" on page 2-6. Also, some specifications were changed on page 2-3. Otherwise, the re-designed module functions the same as the prior designs.

Chapter 2: F2-04AD-1, F2-04AD-1L, 4-Channel Analog Current Input

All specifications are the same for both modules except for the input voltage requirements. Review these specifications to make sure the module meets your application requirements.

Input Specifications	
Number of Channels	4, single ended (one common)
Input Range	4–20 mA current
Resolution	12 bit (1 in 4096)
Step Response	4.9 ms (*4.0 ms) to 95% of full step change
Crosstalk	-80 dB, 1/2 count maximum
Active Low-pass Filtering	-3 dB at 120Hz (*80Hz), 2 poles (-12dB per octave)
Input Impedance	250Ω ±0.1% 1/2 W current input
Absolute Maximum Ratings	±40mA, current input
Converter type	Successive approximation
Linearity Error (End to End)	±1 count (0.025% of full scale) maximum
Input Stability	±1 count
Full Scale Calibration Error (Offset error not included)	±12 counts maximum @ 20mA current input
Offset Calibration Error	±7 counts maximum @ 4mA current input
Maximum Inaccuracy	± 0.5% @ 25°C (77°F) ±0.65% 0–60°C (32–140°F)
Accuracy vs. Temperature	±50ppm/°C maximum full scale calibration (including maximum offset change)
Recommended Fuse (external)	0.032 A, Series 217 fast-acting, current inputs

General Specifications	
PLC Update Rate	1 channel per scan maximum (D2-230 CPU) 4 channels per scan maximum (D2-240, D2-250-1, D2-260 or D2-262 CPU)
Digital Inputs	12 binary data bits, 2 channel ID bits, 2 diagnostic bits
Input points required	16 point (X) input module
Power Budget Requirement	100mA (*50mA maximum, 5VDC (supplied by base)
External Power Supply	F2-04AD-1: 5mA, 10–30 VDC (*80mA max, 18–30 VDC), F2-04AD-1L: *90mA max, 10–15 VDC
Operating Temperature	0°C to 60°C (32°F to 140°F)
Storage Temperature	-20°C to 70°C (-4°F to 158°F)
Relative Humidity	5–95% (non-condensing)
Environmental Air	No corrosive gases permitted
Vibration	MIL STD 810C 514.2
Shock	MIL STD 810C 516.2
Noise Immunity	NEMA ICS3-304



NOTE: Values in parenthesis with an **asterisk** are for older modules with two circuit board design and date codes 0609F3 or previous. Values not in parenthesis are for single circuit board models with date code 0709G or above.

Analog Input Configuration Requirements

The analog input module will appear as a 16-point discrete input module and can be installed in any slot of a DL205 system. The available power budget and discrete I/O points are the limiting factors. For more information check the user manual for the CPU model and I/O base being used regarding power budget and number of local, local expansion or remote I/O points.

Special Placement Requirements (D2-230 and Remote I/O Bases)

Even though the module can be placed in any slot, it is important to examine the configuration if a D2-230 CPU is used, as can be seen in the section about Writing the Program located in this chapter. V-memory locations are used to extract the analog data. If the module is placed so the input points do not start on a V-memory boundary, the instructions cannot access the data. This also applies when placing this module in a remote base using a D2-RSSS in the CPU slot.

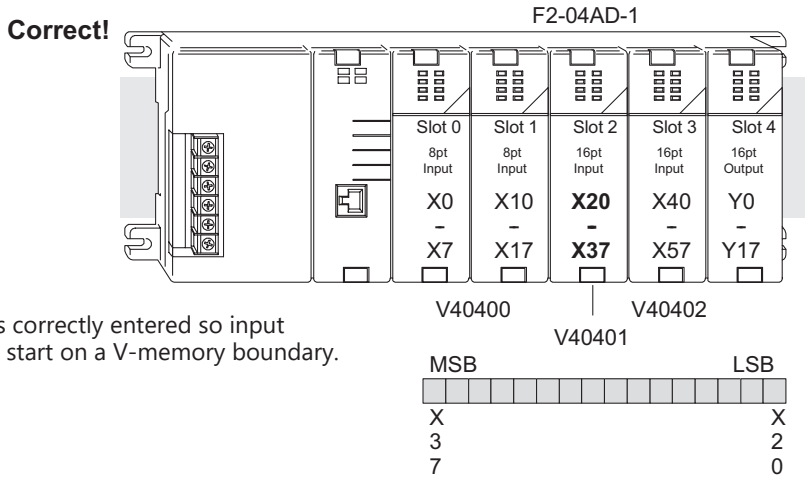

Incorrect

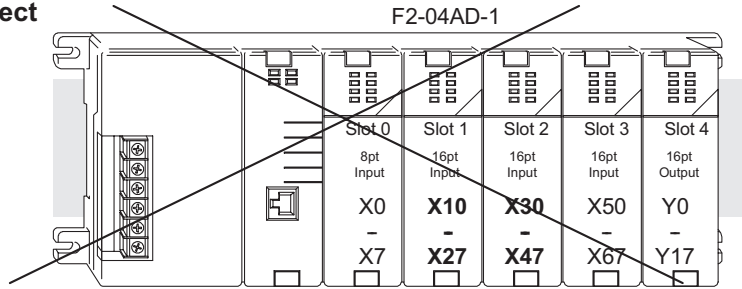

Data is split over two locations, so instructions cannot access data from a D2-230.

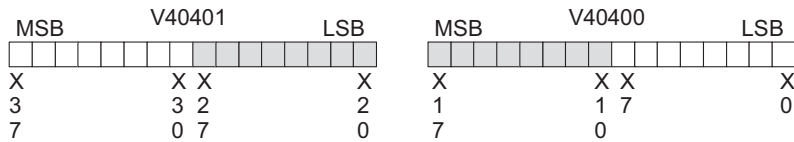

To use the V-memory references required for a D2-230 CPU, the first input address assigned to the module must be one of the following X locations. The table also shows the V-memory addresses that correspond to these X locations.

X	X0	X20	X40	X60	X100	X120	X140	X160
V	V40400	V40401	V40402	V40403	V40404	V40405	V40406	V40407

Setting the Module Jumpers

Selecting the Number of Channels

There are two jumpers, labeled +1 and +2, that are used to select the number of channels that will be used. Use the figures below to locate the jumpers on the module. The module is set from the factory for four channel operation.

The unused channels are not processed, so if only channels 1 thru 3 are selected, then channel 4 will not be active. The following table shows how to use the jumpers to select the number of channels.

No. of Channels	+1	+2
1	No	No
1, 2	Yes	No
1, 2, 3	No	Yes
1, 2, 3, 4	Yes	Yes

For example, to select all 4 channels (1–4), leave both jumpers installed.
To select channel 1, remove both jumpers

Jumper location on modules having date code 0609F3 and previous (two circuit board design)

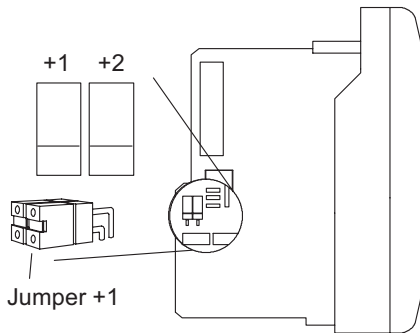

These jumpers are located on the motherboard, the one with the black D-shell style backplane connector.

Jumper location on modules having date code 0709G and above (single circuit board design)

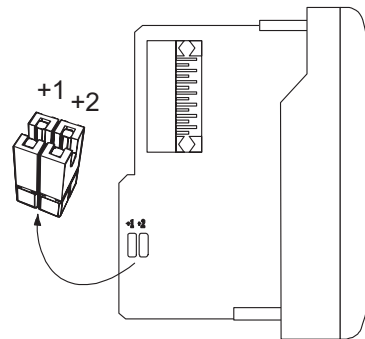

Connecting the Field Wiring

Wiring Guidelines

Your company may have guidelines for wiring and cable installation. If so, check them before starting the installation. Here are some general things to consider:

- Use the shortest wiring route whenever possible.
- Use shielded wiring and ground the shield at the transmitter source. Do not ground the shield at both the module and the source.
- Do not run the signal wiring next to large motors, high current switches, or transformers. This may cause noise problems.
- Route the wiring through an approved cable housing to minimize the risk of accidental damage. Check local and national codes to choose the correct method for your application.

User Power Supply Requirements

The F2-04AD-1 module requires at least one field-side power supply. The same or separate power sources can be used for the module supply and the current transmitter supply. The module requires 10–30 VDC, at 5mA, from the external power supply. The DL205 AC bases have a built-in 24VDC power supply that provide up to 300mA of current. This can be used instead of a separate supply. Check the power budget to be safe.

It is desirable in some situations to power the transmitters separately in a location remote from the PLC. This will work as long as the transmitter supply meets the voltage and current requirements, and the transmitter's minus (-) side and the module supply's minus (-) side are connected together.



WARNING: If using the 24VDC base power supply, make sure to calculate the power budget. Exceeding the power budget can cause unpredictable system operation that can lead to a risk of personal injury or damage to equipment.

The DL205 base has a switching type power supply. As a result of switching noise, ± 3 – 5 counts of instability may be noticed in the analog input data if the base power supply is used. If this is unacceptable, try one of the following:

1. Use a separate linear power supply.
2. Connect the 24VDC common to the frame ground, which is the screw terminal marked on the screw terminal marked "G" on the base.

By using these methods, the input stability is rated at ± 1 count.

Current Loop Transmitter Impedance

Standard 4–20 mA transmitters and transducers can operate from a wide variety of power supplies. Not all transmitters are alike and the manufacturers often specify a minimum loop or load resistance that must be used with the transmitter.

The F2-04AD-1, provides 250Ω resistance for each channel. If the transmitter being used requires a load resistance below 250Ω, it is not necessary to make any adjustments. However, if the transmitter requires a load resistance higher than 250Ω, a resistor will need to be added in series with the input.

Consider the following example for a transmitter being operated from a 30VDC supply with a recommended load resistance of 750Ω. Since the module has a 250Ω resistor, an additional resistor needs to be added.

$$R = Tr - Mr$$
$$R = 750 - 250$$
$$R \geq 500$$

R - Resistor to add
Tr - Transmitter Requirement
Mr - Module resistance (internal 250Ω)

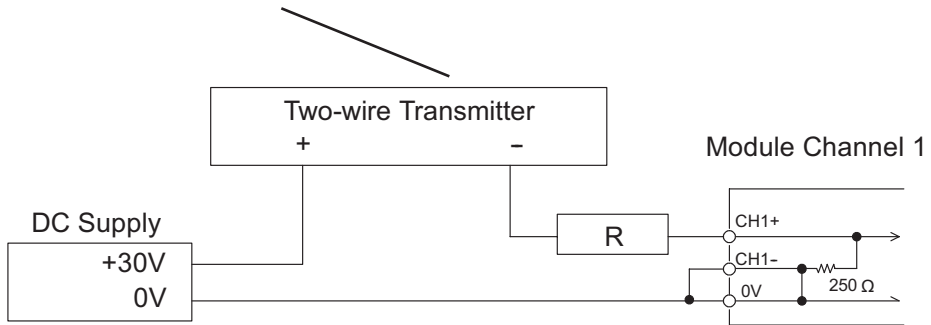

Wiring Diagram

The F2-04AD-1 module has a removable connector to simplify wiring the module. Just squeeze the top and bottom retaining clips and gently pull the connector from the module. Use the following diagram to connect the field wiring

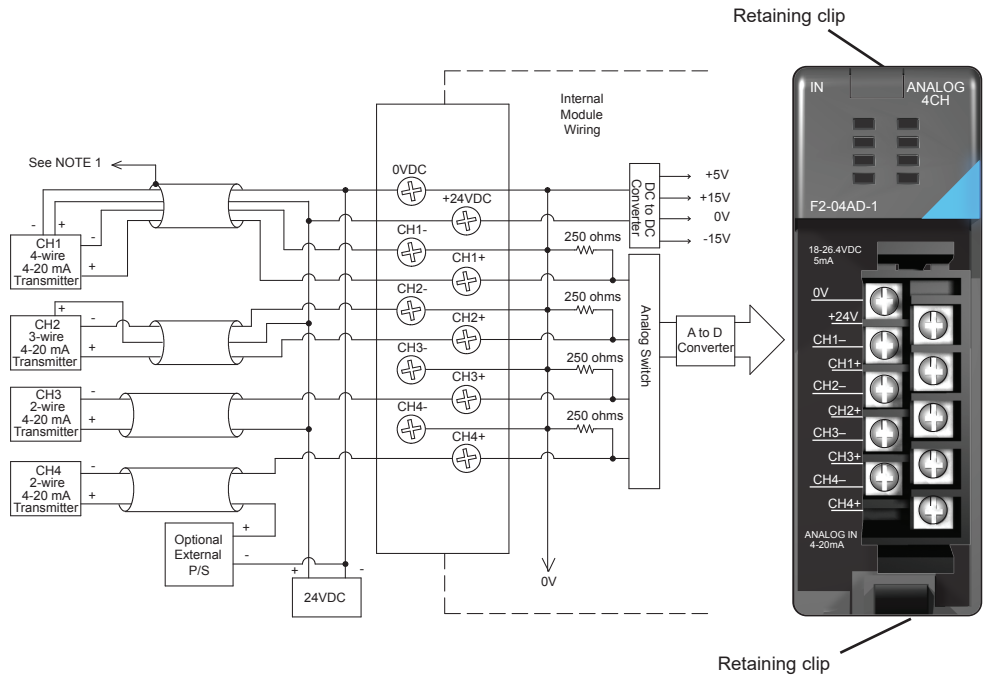

NOTE 1: Shields should be grounded at the signal source.

NOTE 2: More than one external power supply can be used, provided all the power supply commons are connected.

NOTE 3: A Series 217, 0.032 A fast-acting fuse is recommended for 4-20 mA current loops.

NOTE 4: If the power supply common of an external power supply is not connected to 0 VDC on the module, then the output of the external transmitter must be isolated. To avoid "ground loop" errors, recommended 4-20 mA transmitter types are:

2 or 3 wire: Isolation between input signal and power supply.

4 wire: Isolation between input signal, power supply, and 4-20 mA output.

Module Operation

Channel Scanning Sequence (Multiplexing) for a D2-230 CPU

Before beginning to write the control program, it is important to take a few minutes to understand how the module processes and represents the analog signals.

The module can supply different amounts of data per scan, depending on the type of CPU being used. The D2-230 can obtain one channel of data per CPU scan. Since there are four channels, it can take up to four scans to get data for all channels. Once all channels have been scanned the process starts over with channel 1. Unused channels are not processed, so if only two channels are selected, then each channel will be updated every other scan. The multiplexing method can also be used for the D2-240, D2-250-1, D2-260 and D2-262 CPUs.

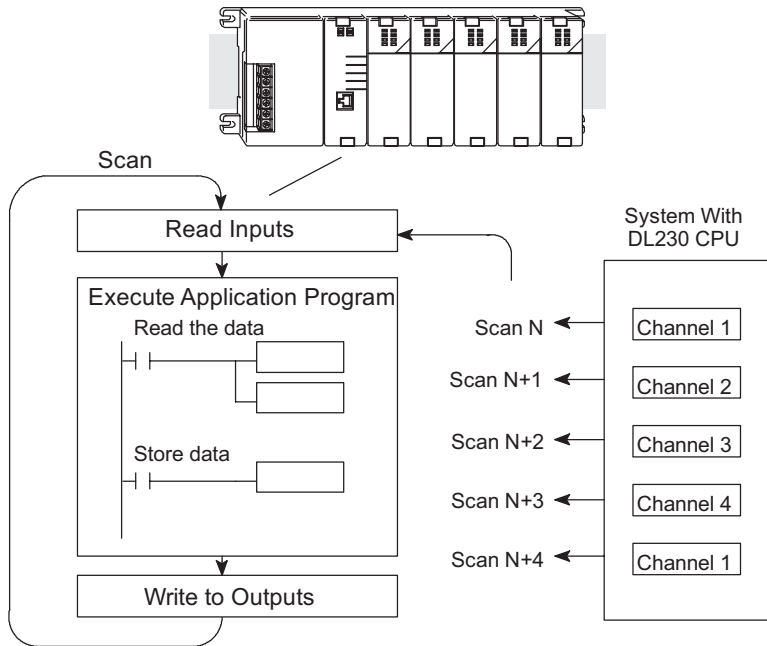

Channel Scanning Sequence (Pointer method) for D2-240, D2-250-1, D2-260 or D2-262 CPU

If a D2-240, a D2-250-1, a D2-260 or a D2-262 CPU is used, all four channels of input data can be collected in one scan. This is because the D2-240, D2-250-1, D2-260 and D2-262 CPU supports special V-memory locations that are used to manage the data transfer. This is discussed in more detail in the section on Writing the Control Program later in this chapter.

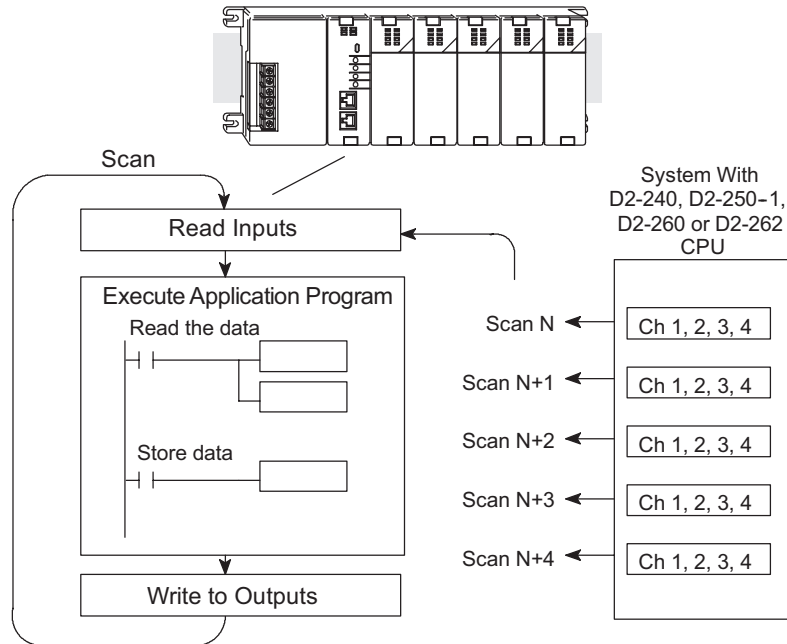

Analog Module Updates

Even though the channel updates to the CPU are synchronous with the CPU scan, the module asynchronously monitors the analog transmitter signal and converts the signal to a 12-bit binary representation. This enables the module to continuously provide accurate measurements without slowing down the discrete control logic in the RLL program.

For the vast majority of applications, the values are updated much faster than the signal changes. However, in some applications, the update time can be important. The module takes approximately 4.9 milliseconds to sense 95% of the change in the analog signal.



NOTE: This is not the amount of time required to convert the signal to a digital representation. The conversion to the digital representation takes only a few microseconds. Many manufacturers list the conversion time, but it is the settling time of the filter that really determines the update time.

Understanding the Input Assignments

It was mentioned earlier in this chapter that the F2-04AD-1 module appears as a 16-point discrete input module to the CPU. These points can be used to obtain:

- An indication of which channel is active
- The digital representation of the analog signal
- Module diagnostic information

Since all input points are automatically mapped into V-memory, it is very easy to determine the location of the data word that will be assigned to the module.

Within these word locations, the individual bits represent specific information about the analog signal.

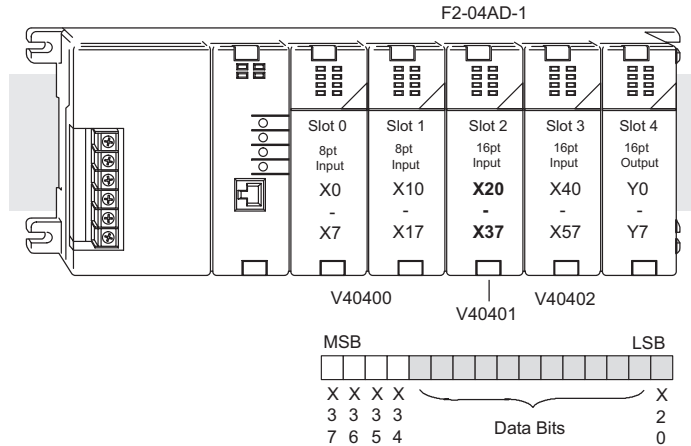

Analog Data Bits

The first twelve bits represent the analog data in binary format.

Bit	Value	Bit	Value
0	1	6	64
1	2	7	128
2	4	8	256
3	8	9	512
4	16	10	1024
5	32	11	2048

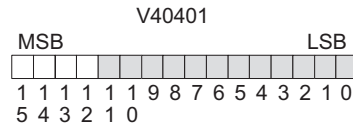

□ = data bits

Active Channel Indicator Inputs

Two of the inputs are binary-encoded to indicate the active channel (remember, the V-memory bits are mapped directly to discrete inputs). The inputs are automatically turned on and off to indicate the active channel for each scan.

Scan	X35	X34	Channel
N	Off	Off	1
N+1	Off	On	2
N+2	On	Off	3
N+3	On	Off	4
N+4	Off	Off	1

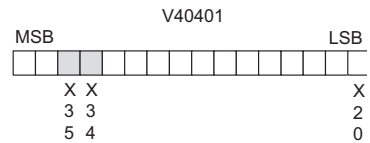

Module Diagnostic Inputs

The last two inputs are used for module diagnostics.

Module Busy - The first diagnostic input (X36 in this example) indicates a "busy" condition. This input will always be active on the first PLC scan, to tell the CPU the analog data is not valid. After the first scan, the input usually only comes on when extreme environmental (electrical) noise problems are present.

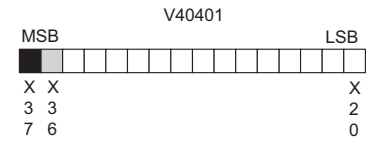

The programming examples in the next section shows how this input can be used. The wiring guidelines shown earlier in this chapter provide steps that can help reduce noise problems.

Missing 24VDC - The last diagnostic input (X37 in this example) indicates that 24VDC has not been applied to the card. For example, when using the multiplexing method, if the 24VDC input power is missing or if the terminal block is loose, the module will turn on this input point and it also returns a data value of zero to further indicate there is a problem. If using the pointer method, the value placed into the V-memory location will be 8000 instead of bit 15 (i.e. X37 in this example) being set.

The next section, Writing the Control Program, explains how these inputs can be used in a program.

Module Resolution

Since the module has 12-bit resolution, the analog signal is converted into 4096 counts ranging from 0 - 4095 (2¹²). For example, a 4mA signal would be 0 and a 20mA signal would be 4095. This is equivalent to a binary value of 0000 0000 0000 to 1111 1111 1111, or 000 to FFF hexadecimal. The diagram shows how this relates to the signal range.

Each count can also be expressed in terms of the signal level by using the equation shown.

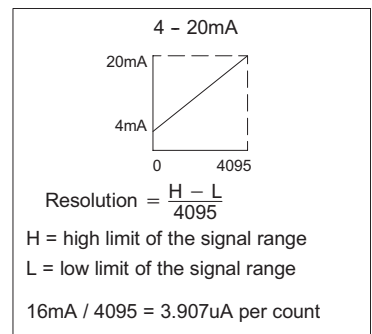

Writing the Control Program

Reading Values: Pointer Method and Multiplexing

There are two methods which can be used to read values:

- The pointer method
- Multiplexing

The multiplexing method must be used when using a D2-230 CPU. The multiplexing method must also be used with remote I/O modules (the pointer method will not work). Either method can be used with the D2-240, D2-250-1, D2-260 and D2-262 CPUs, but for ease of programming it is strongly recommended to use the pointer method.

Pointer Method for D2-240, D2-250-1, D2-260 and D2-262

The DL205 series has special V-memory locations assigned to each base slot that will greatly simplify the programming requirements. These V-memory locations allow you to:

- Specify the data format
- Specify the number of channels to scan
- Specify the storage locations.



NOTE: D2-250 CPUs with firmware release version 1.06 or later support this method. If the D2-230 example needs to be used, module placement in the base is very important. Review the section earlier in this chapter for guidelines.

The example program shows how to setup these locations. Place this rung anywhere in the ladder program, or in the initial stage if stage programming instructions are being used. This is all that is required to read the data into V-memory locations. Once the data is in V-memory, math can be used on the data to compare the data against preset values, and so forth. V2000 is used in the example but you can use any user V-memory location. In this example the module is installed in slot 2. Be sure to use the V-memory locations for the module placement. The pointer method automatically converts values to BCD (depending on the LD statement in the ladder logic).

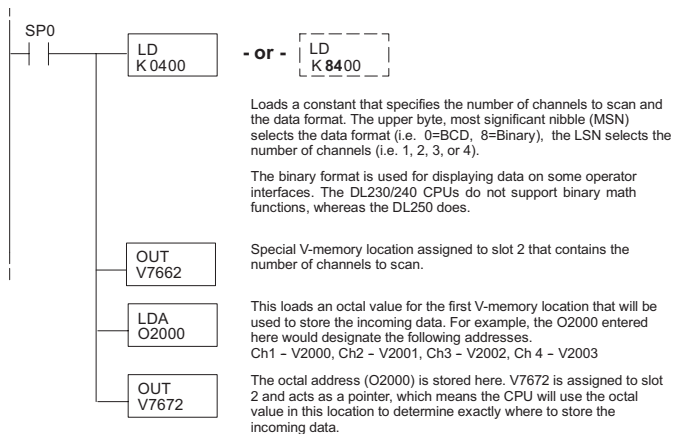

The tables below show the special V-memory locations used by the D2-240, D2-250-1, D2-260 and D2-262 for the CPU base and local expansion base I/O slots. Slot 0 (zero) is the module next to the CPU or the D2-CM module. Slot 1 is the module two places from the CPU or the D2-CM, and so on. Remember, the CPU only examines the pointer values at these locations after a mode transition. Also, if the D2-230 (multiplexing) method is used, verify that these addresses in the CPU are zero.

The table below applies to the D2-240, D2-250-1, D2-260 and D2-262 CPU base.

CPU Base: Analog Input Module Slot-Dependent V-memory Locations								
Slot	0	1	2	3	4	5	6	7
No. of Channels	V7660	V7661	V7662	V7663	V7664	V7665	V7666	V7667
Storage Pointer	V7670	V7671	V7672	V7673	V7674	V7675	V7676	V7677

The table below applies to the D2-250-1, D2-260 or D2-262 expansion base 1.

Expansion Base D2-CM #1: Analog Input Module Slot-Dependent V-memory Locations								
Slot	0	1	2	3	4	5	6	7
No. of Channels	V36000	V36001	V36002	V36003	V36004	V36005	V36006	V36007
Storage Pointer	V36010	V36011	V36012	V36013	V36014	V36015	V36016	V36017

The table below applies to the D2-250-1, D2-260 or D2-262 expansion base 2.

Expansion Base D2-CM #2: Analog Input Module Slot-Dependent V-memory Locations								
Slot	0	1	2	3	4	5	6	7
No. of Channels	V36100	V36101	V36102	V36103	V36104	V36105	V36106	V36107
Storage Pointer	V36110	V36111	V36112	V36113	V36114	V36115	V36116	V36117

The table below applies to the D2-260 and D2-262 CPU expansion base 3.

Expansion Base D2-CM #3: Analog Input Module Slot-Dependent V-memory Locations								
Slot	0	1	2	3	4	5	6	7
No. of Channels	V36200	V36201	V36202	V36203	V36204	V36205	V36206	V36207
Storage Pointer	V36210	V36211	V36212	V36213	V36214	V36215	V36216	V36217

The table below applies to the D2-260 and D2-262 CPU expansion base 4.

Expansion Base D2-CM #4: Analog Input Module Slot-Dependent V-memory Locations								
Slot	0	1	2	3	4	5	6	7
No. of Channels	V36300	V36301	V36302	V36303	V36304	V36305	V36306	V36307
Storage Pointer	V36310	V36311	V36312	V36313	V36314	V36315	V36316	V36317

Reading Values (Multiplexing) for D2-230, D2-240, D2-250-1, D2-260 and D2-262 CPUs

The D2-230 CPU does not have the special V-memory locations which will allow data transfer to be automatically enabled. Since all channels are multiplexed into a single data word, the control program must be setup to determine which channel is being read. Since the module appears as X input points to the CPU, it is very easy to use the active channel status bits to determine which channel is being monitored.



NOTE: This example is for a module installed as shown in the previous examples. The addresses used would be different if the module was installed in a different I/O arrangement. The rungs can be placed anywhere in the program, or if stage programming is being used, place them in a stage that is always active.

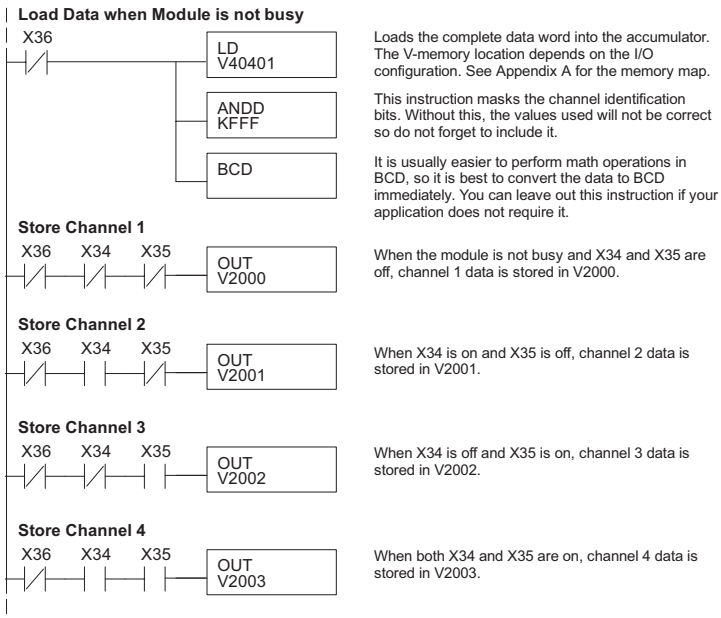

Single Channel Selected

Since it isn't necessary to know which channel is selected, the single channel program is even more simple as shown in the example below.

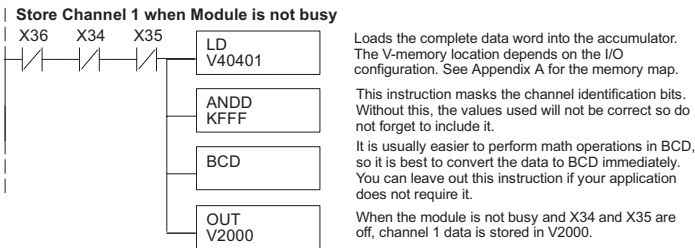

Analog Power Failure Detection

The Analog module has an on-board processor that can diagnose analog input circuit problems. A ladder rung can be edited to detect these problems. This rung shows an input point that would be assigned if the module was installed as shown in the previous examples. A different point would be used if the module was installed in a different I/O arrangement.

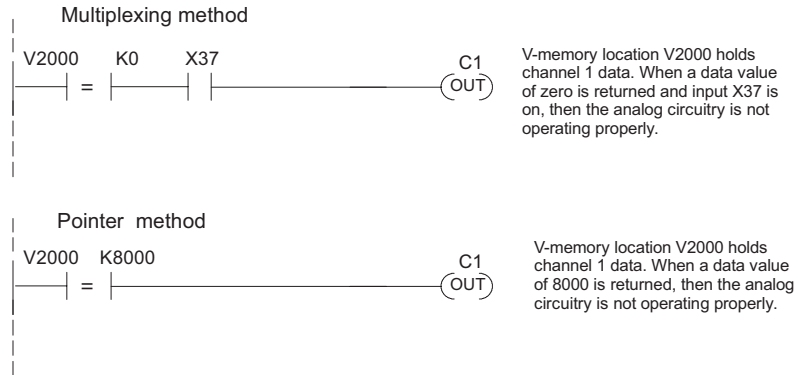

Scaling the Input Data

Most applications require measurements in engineering units which provides more meaningful data. This is accomplished by using the conversion formula shown.

Adjustments may be needed to the formula depending on the scale being used for the engineering units.

For example, if pressure (psi) is to be measured from 0.0 – 99.9 then multiply the value by 10 in order to imply a decimal place when viewing the value with the programming software or with a handheld programmer. Notice how the calculations differ when the multiplier is used.

An analog value of 2024, slightly less than half scale, should yield 49.4 psi.

$$\text{Units} = A \frac{H-L}{4095}$$

U = Engineering Units
 A = Analog Value (0 – 4095)
 H = High limit of the engineering unit range
 L = Low limit of the engineering unit range

Example without multiplier

$$\text{Units} = A \frac{H-L}{4095}$$

$$\text{Units} = 2024 \frac{100-0}{4095}$$

$$\text{Units} = 49$$

Example with multiplier

$$\text{Units} = 10A \frac{H-L}{4095}$$

$$\text{Units} = 20240 \frac{100-0}{4095}$$

$$\text{Units} = 494$$

The Conversion Program

The following example shows how to write the program to perform the engineering unit conversion. This example assumes that the data is in BCD and loaded into the appropriate V-memory locations using instructions that apply the CPU being used in the PLC.



NOTE: This example uses SP1, which is always on, but any permissive contact such as X, C, etc., can be used.

Analog and Digital Value Conversions

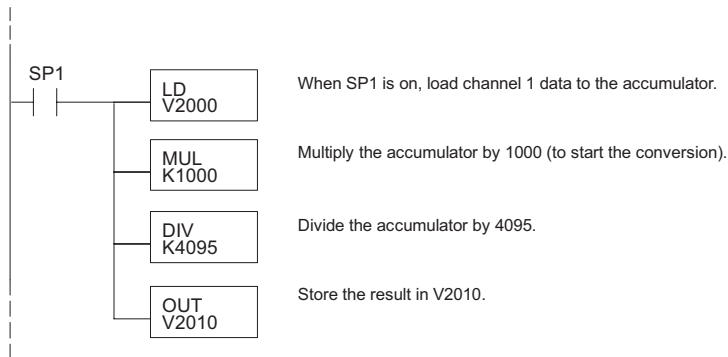

Sometimes it is useful to be able to quickly convert between the signal levels and the digital values. This is especially helpful during machine startup or troubleshooting. The following table provides formulas to make this conversion more simple.

Range	If the digital value is known	If the analog signal level is known.
4–20 mA	$A = 16D + 4$ 4095	$D = \frac{4095(A - 4)}{16}$

As an example, if the measured signal is 10mA, the formula can be used to easily determine the digital value that will be stored in the V-memory location that contains the data.

$$D = \frac{4095(A - 4)}{16}$$

$$D = \frac{4095(10\text{mA} - 4)}{16}$$

$$D = (255.93) (6)$$

$$D = 1536$$

Filtering Input Noise for D2-250-1, D2-260 and D2-262 CPUs Only

Add the following logic to filter and smooth analog input noise in D2-250-1, D2-260 and D2-262 CPUs. This is especially useful when using PID loops. Noise can be generated by the field device and/or induced by field wiring.

In the following example, the analog value in BCD is first converted to a binary number. Memory location V1400 is the designated work space in this example. The MULR instruction is the filter factor, which can be from 0.1 to 0.9. The example uses 0.2. A smaller filter factor increases filtering. A higher precision value can be used, but it is not generally needed. The filtered value is then converted back to binary and then to BCD. The filtered value is stored in location V1402 for use in your application or PID loop.

NOTE: Please review intelligent instructions (IBox) in Chapter 5 of D2-USER-M, which simplify this and other functions. The IBox instructions are supported by the D2-250-1, D2-260 and D2-262 CPUs.



NOTE: Be careful not to do a multiple number conversion on a value. For example, if you are using the pointer method to get the analog value, it is in BCD and must be converted to binary. However, if you are using the conventional method of reading analog and are masking the first twelve bits, then it is already in binary and no conversion using the BIN instruction is needed.

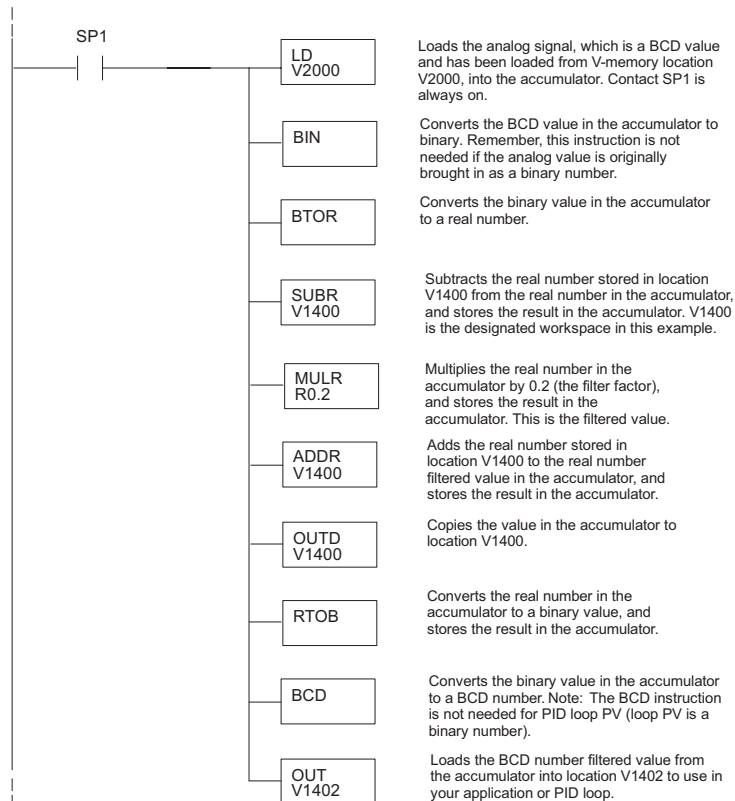

F2-04AD-2, F2-04AD-2L 4-CHANNEL ANALOG VOLTAGE INPUT



In This Chapter...

Module Specifications	3-2
Setting the Module Jumpers	3-5
Connecting the Field Wiring	3-7
Module Operation	3-10
Understanding Input Assignments	3-12
Writing the Control Program.....	3-15

Module Specifications

F2-04AD-2

The F2-04AD-2 analog Input module provides several hardware features.

- Analog inputs are optically isolated from the PLC logic.
- The module has a removable terminal block so the module can be easily removed or changed without disconnecting the wiring.
- With a D2-240, D2-250-1, D2-260 and D2-262 CPU, all four channels can be read in one scan.
- On-board active analog filtering and microcontroller provide digital signal processing to maintain precision analog measurements in noisy environments..

F2-04AD-2L is Obsolete

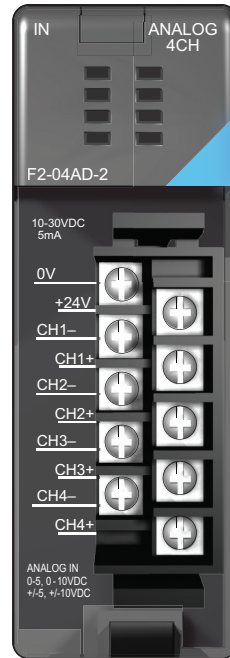

F2-04AD-2



NOTE: In 2009 the F2-04AD-2L was discontinued. A re-designed F2-04AD-2 was released at the same time which can be powered by either 12VDC or 24VDC input power supplies. This new module is a direct replacement for prior F2-04AD-2 and all F2-04AD-2L modules. The new module is a single circuit board design and the jumper link locations are different. See *Setting the Module Jumpers* on page 3-5. Also, some specifications were changed on page 3-3. Otherwise, the re-designed module functions the same as the prior designs.

Analog Input Configuration Requirements

The F2-04AD-2 analog input module requires 16 discrete input points and can be installed in any slot of a DL205 system. The available power budget and discrete I/O points are the limiting factors. For more information regarding power budget and number of local, local expansion or remote I/O points, check the user manual for the particular CPU model and I/O base being used.

Chapter 3: F2-04AD-2, F2-04AD-2L, 4-Channel Analog Voltage Input

All specifications are the same for both modules except for the input voltage requirements. Review these specifications to make sure the module meets your application requirements.

Input Specifications	
Number of Channels	4, single ended (one common)
Input Range	0–5 VDC, 0–10 VDC, $\pm 5V$, $\pm 10V$
Resolution	12 bit (1 in 4096) unipolar (0–4096) 13 bit (1 in 8192) bipolar (-4095 to +4095)
Common Mode Rejection	-50db at 800Hz
Step Response	8.2 ms (*10ms) to 95% of full step change
Crosstalk	-70db, 1 count maximum
Active Low-pass Filtering	-3 db at 80Hz, 2 poles (-12db per octave)
Input Impedance	Greater than 20M Ω
Absolute Maximum Ratings	$\pm 75VDC$
Converter Type	Successive approximation
Linearity Error (End to End)	± 1 count (0.025% of span) maximum unipolar ± 2 counts maximum bipolar
Input Stability	± 1 count
Full Scale Calibration Error (Offset error included)	± 3 counts maximum
Offset Calibration Error	± 1 count maximum (0V input)
Maximum Inaccuracy	$\pm 0.1\%$ @ 25°C (77°F) $\pm 0.3\%$ 0–60°C (32–140°F)
Accuracy vs. Temperature	± 50 ppm / °C full scale calibration change (including maximum offset change of 2 counts)

General Specifications	
PLC Update Rate	1 channel per scan maximum (D2-230 CPU) 4 channels per scan maximum (D2-240/D2-250-1/D2-260/D2-262 CPU)
Digital Inputs Input points required	12 binary data bits, 2 channel ID bits, 1 sign/diagnostic bit, 1 diagnostic bit 16 point (X) input module
Power Budget Requirement	110mA (*60mA maximum, 5VDC (supplied by base)
External Power Supply	F2-04AD-2: 5mA, 10–30 VDC (*90mA max, 18–26.4 VDC) F2-04AD-2L: *90mA max, 10–15 VDC
Operating Temperature	0°C to 60°C (32°F to 140°F)
Storage Temperature	-20°C to 70°C (-4°F to 158°F)
Relative Humidity	5–95% (non-condensing)
Environmental Air	No corrosive gases permitted
Vibration	MIL STD 810C 514.2
Shock	MIL STD 810C 516.2
Noise Immunity	NEMA ICS3-304



NOTE: Values in parenthesis with an asterisk are for older modules with two circuit board design and date codes 0609F4 and previous. Values not in parenthesis are for single circuit board models with date code 0709G and above.

Special Placement Requirements (D2-230 and Remote I/O Bases)

Even though the module can be placed in any slot, it is important to examine the configuration if a D2-230 CPU is used, as can be seen in the section about Writing the Program, located in this chapter. V-memory locations are used to extract the analog data. If the module is placed so the input points do not start on a V-memory boundary, the instructions cannot access the data. This also applies when placing this module in a remote base using a D2-RSSS in the CPU slot.

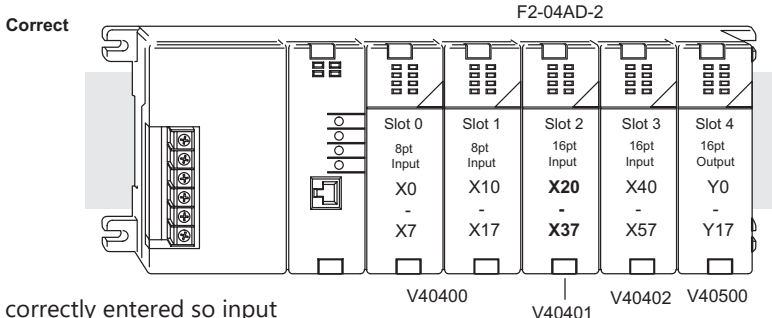

Data is correctly entered so input points start on a V-memory boundary.

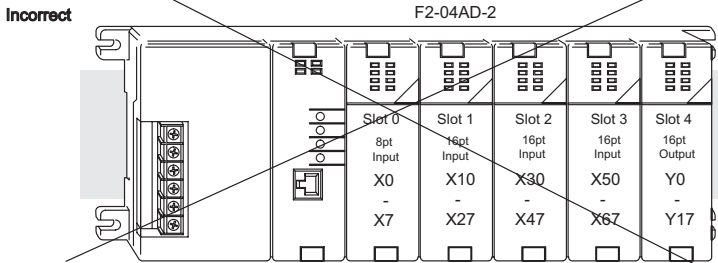
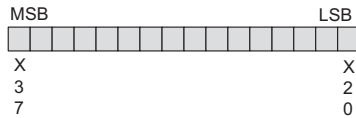

Data is split over two locations, so instructions cannot access data from a D2-230.

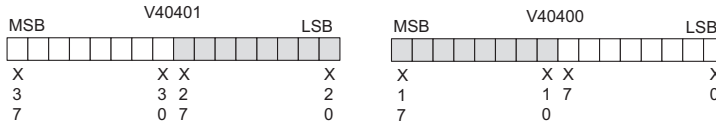

To use the V-memory references required for a D2-230 CPU, the first input address assigned to the module must be one of the following X locations. The table also shows the V-memory addresses that correspond to these X locations.

X	X0	X20	X40	X60	X100	X120	X140	X160
V	V40400	V40401	V40402	V40403	V40404	V40405	V40406	V40407

Setting the Module Jumpers

Selecting the Number of Channels

There are two jumpers, labeled +1 and +2, that are used to select the number of channels that will be used. Use the figures below to locate the jumpers on the module. The module is set from the factory for four channel operation.

The unused channels are not processed, so if only channels 1 through 3 are selected, then channel 4 will not be active. The following table shows how to place the jumpers to select the number of channels.

No. of Channels	+1	+2
1	No	No
1, 2	Yes	No
1, 2, 3	No	Yes
1, 2, 3, 4	Yes	Yes

Yes = jumper installed
 No = jumper removed

For example, to select all 4 channels (1 - 4), leave both jumpers installed. To select channel 1, remove both jumpers

Jumper location on modules having Date Code 0609F4 and previous (two circuit board design)

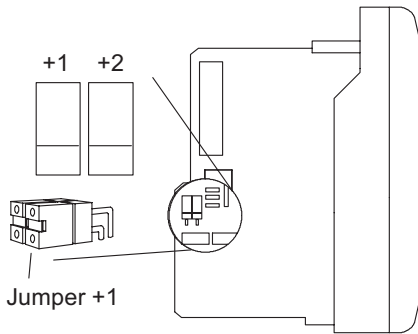

These jumpers are located on the motherboard, the one with the black D-shell style backplane connector.

Jumper location on modules having Date Code 0709G and above (single circuit board design)

Use jumpers +1 and +2 to select number of channels.

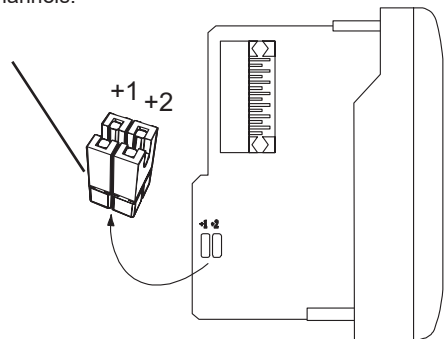

Selecting the Input Signal Range

There is another jumper, labeled either J2 or J3 that is used to select between the 5V ranges and the 10V ranges (depending whether it is a single or double circuit board module). See the figures below to locate the jumper on the module being used. The module comes from the factory set for 10V operation (jumper not installed).



Note: *Install jumper J2 or J3 for 0–5 V or ±5V operation.
Remove J2 or J3, or store on a single pin, for 0–10 V or ±10V operation.*

Jumper J2 location on modules having Date Code 0609F4 and previous (two circuit board design)

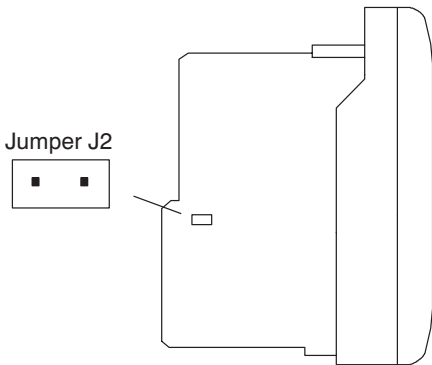

Jumper J2 is located on the smaller circuit board, which is on top of the motherboard.

Install J2 for 0–5 V or ±5V operation.
Remove J2, or store on a single pin, for 0–10 V or ±10V operation.

Jumper J3 location on modules having Date Code 0709G and above (single circuit board design)

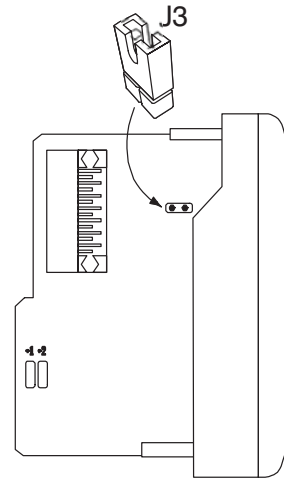

Install J3 for 0–5 V or ±5V operation.
Remove J3, or store on a single pin, for 0–10 V or ±10V operation.

Connecting the Field Wiring

Wiring Guidelines

Your company may have guidelines for wiring and cable installation. If so, check them before starting the installation. Here are some general things to consider:

- Use the shortest wiring route whenever possible.
- Use shielded wiring and ground the shield at the transmitter source. Do not ground the shield at both the module and the source.
- Do not run the signal wiring next to large motors, high current switches, or transformers. This may cause noise problems.
- Route the wiring through an approved cable housing to minimize the risk of accidental damage. Check local and national codes to choose the correct method for your application.

User Power Supply Requirements

The F2-04AD-2 module requires at least one field-side power supply. The same or separate power sources can be used for the module supply and the voltage transmitter supply. The module requires 10–30 VDC, at 5mA, from the external power supply.

The DL205 AC bases have a built-in 24VDC power supply that provide up to 300mA of current. This can be used instead of a separate supply. Check the power budget to be safe.

It is desirable in some situations to power the transmitters separately in a location remote from the PLC. This will work as long as the transmitter supply meets the voltage and current requirements, and the transmitter's minus (-) side and the module supply's minus (-) side are connected together.



WARNING: If the 24VDC base power supply is used, Be sure to calculate the power budget. Exceeding the power budget can cause unpredictable system operation that can lead to a risk of personal injury or damage to equipment.

The DL205 base has a switching type power supply. As a result of switching noise, ± 3 – 5 counts of instability may be noticed in the analog input data if this power supply is used. If this is unacceptable, try using one of the following.

1. Use a separate linear power supply.
2. Connect the 24VDC common to the frame ground, which is the screw terminal marked on the screw terminal marked "G" on the base.
3. By using these methods, the input stability is rated at ± 1 count.

Custom Input Ranges

At times, there may be a need to connect a (current) transmitter with an unusual signal range. By changing the wiring slightly and adding an external resistor to convert the current to voltage, the module can be easily adapted to meet the specifications for a transmitter that does not adhere to one of the standard input ranges. The following diagram shows how this can be done. The example below only shows channel 1, but the other channels can be used as well.

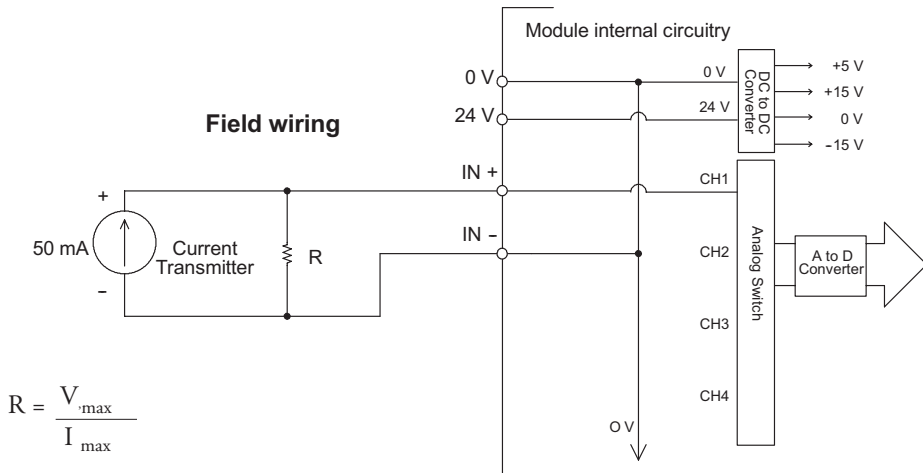

$$R = \frac{V_{\max}}{I_{\max}}$$

R = value of external resistor

V_{\max} = high limit of selected voltage range (5V or 10V)

I_{\max} = maximum current supplied by the transmitter

Example: current transmitter capable of 50mA, 0–10 V range selected.

$$R = \frac{10V}{50mA} \quad R = 200\Omega$$



NOTE: The choice of resistor can affect the accuracy of the module. A resistor that has $\pm 0.1\%$ tolerance and a ± 50 ppm/ $^{\circ}\text{C}$ temperature coefficient is recommended.

If a 4–20 mA signal is used and converted to voltage using this method, a broken transmitter condition can easily be detected. For example, if using the 0–5V range and the lowest signal for the 4–20 mA transmitter is 4mA, the lowest digital value for the signal is not 0, but instead is 819.

If the transmitter is working properly, the smallest value would be 819 in the DL205. If the value is less than about 750 (allowing for tolerance), then the transmitter is broken.

Wiring Diagram

The module has a removable connector to simplify wiring the module. Just squeeze the top and bottom retaining clips and gently pull the connector from the module. Use the following diagram to connect the field wiring

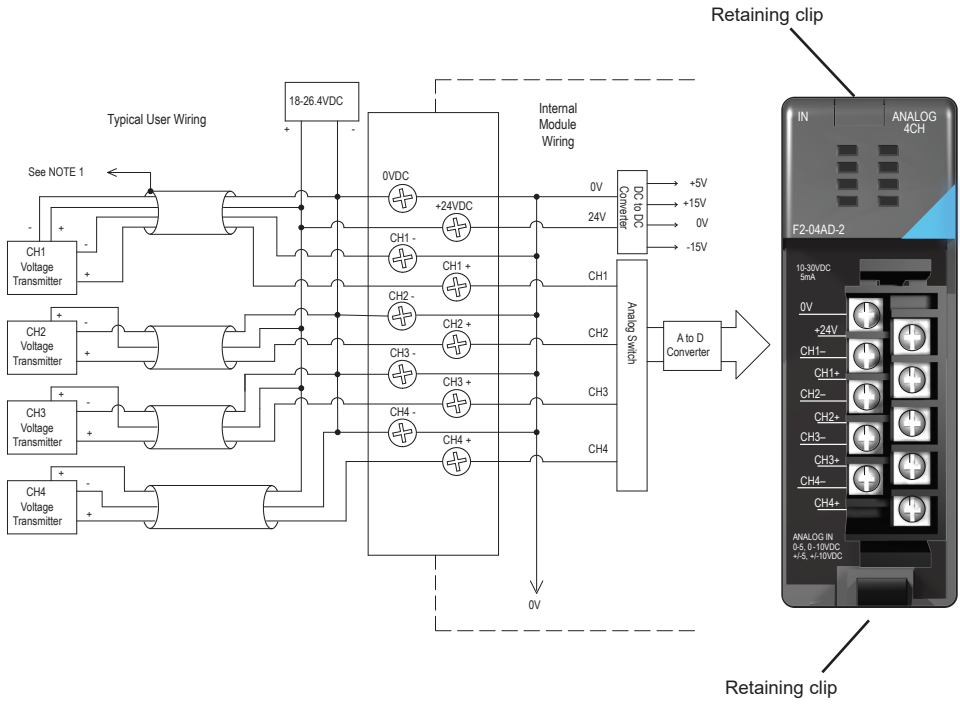

NOTE: Shields should be grounded at the signal source.

Module Operation

Channel Scanning Sequence (Multiplexing) for a D2-230 CPU

Before beginning to write the control program, it is important to take a few minutes to understand how the module processes and represents the analog signals.

Depending on the type of CPU being used, the module can supply different amounts of data per scan. The D2-230 can obtain one channel of data per CPU scan. Since there are four channels, it can take up to four scans to get data for all channels. Once all channels have been scanned the process starts over with channel 1. Unused channels are not processed, so if only two channels are selected, then each channel will be updated every other scan. The multiplexing method can also be used for the D2-240, 250-1, D2-260 and D2-262 CPUs.

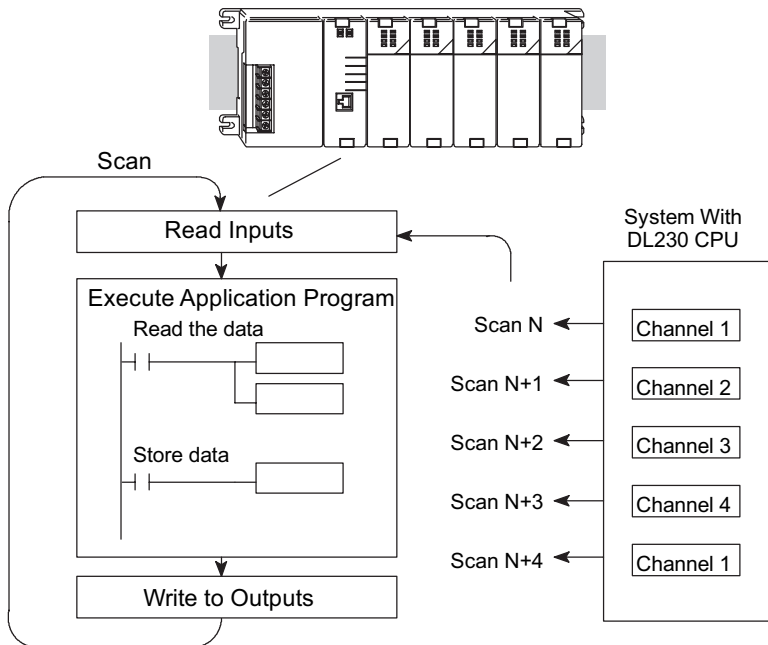

Channel Scanning Sequence (Pointer method) for D2-240, D2-250-1, D2-260 or D2-262 CPUs

If either a D2-240, a D2-250-1, a D2-260 or a D2-262 CPU are used, all four channels of input data can be collected in one scan. This is because the D2-240, D2-250-1, D2-260 and D2-262 CPUs support special V-memory locations that are used to manage the data transfer. This is discussed in more detail in the section on Writing the Control Program later in this chapter.

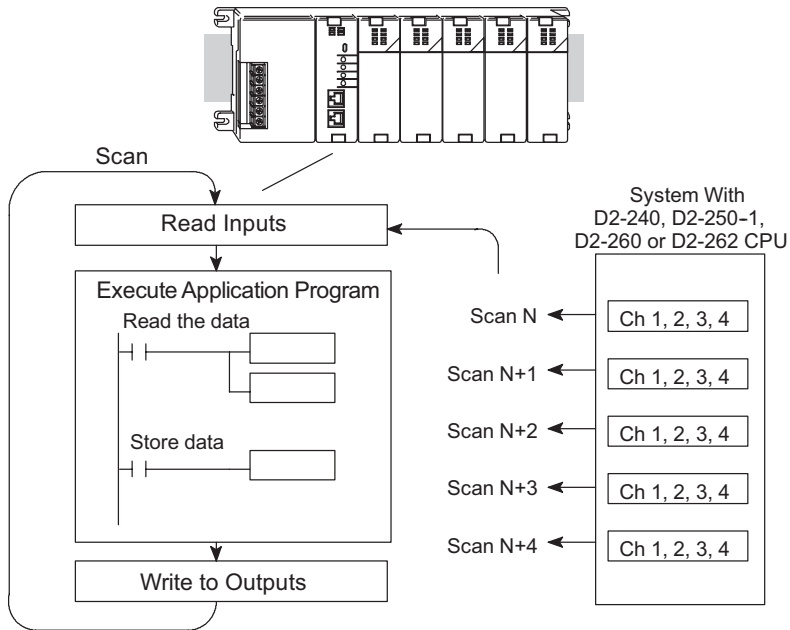

Analog Module Updates

Even though the channel updates to the CPU are synchronous with the CPU scan, the module asynchronously monitors the analog transmitter signal and converts the signal to a 12-bit binary representation. This enables the module to continuously provide accurate measurements without slowing down the discrete control logic in the RLL program.

For the vast majority of applications, the values are updated much faster than the signal changes. However, in some applications, the update time can be important. The module takes approximately 8.2 milliseconds to sense 95% of the change in the analog signal.



NOTE: This is not the amount of time required to convert the signal to a digital representation. The conversion to the digital representation takes only a few microseconds. Many manufacturers list the conversion time, but it is the settling time of the filter that really determines the update time.

Understanding Input Assignments

It was mentioned earlier in this chapter that the F2-04AD-2 module appears as a 16-point discrete input module to the CPU. These points can be used to obtain:

- An indication of which channel is active
- The digital representation of the analog signal
- Module diagnostic information

Since all input points are automatically mapped into V-memory, it is very easy to determine the location of the data word that will be assigned to the module.

Within these word locations, the individual bits represent specific information about the analog signal.

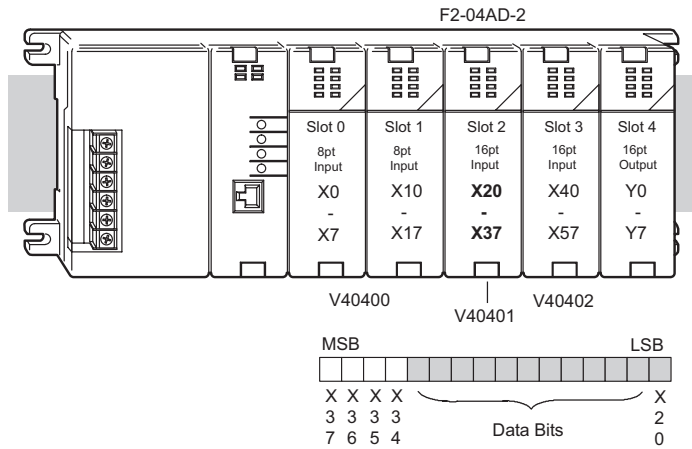

Analog Data Bits

The first twelve bits represent the analog data in binary format.

Bit	Value	Bit	Value
0	1	6	64
1	2	7	128
2	4	8	256
3	8	9	512
4	16	10	1024
5	32	11	2048

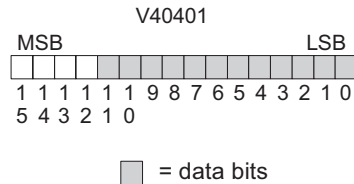

Active Channel Indicator Inputs

Two of the inputs are binary-encoded to indicate the active channel (remember, the V-memory bits are mapped directly to discrete inputs). The inputs automatically turn on and off to indicate the current channel for each scan.

Scan	X35	X34	Channel
N	Off	Off	1
N+1	Off	On	2
N+2	On	Off	3
N+3	On	On	4
N+4	Off	Off	1

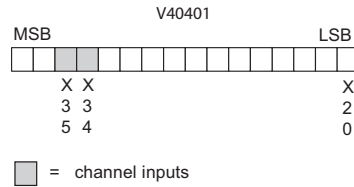

Module Diagnostic and Sign Inputs

The last two inputs are used for module diagnostics.

Module Busy - The first diagnostic input (X36 in this example) indicates a “busy” condition. This input will always be active on the first PLC scan, to tell the CPU the analog data is not valid. After the first scan, the input usually only comes on when extreme environmental (electrical) noise problems are present.

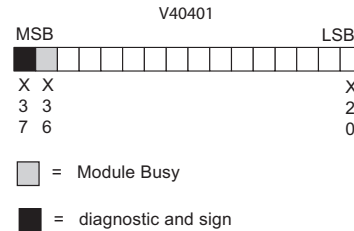

The last input (X37 in this example) is used for two purposes.

Signal Sign - When using bipolar ranges the value returned needs to be known if it is either positive or negative. When this input is off, the value stored represents a positive analog signal (0V or greater). If the input is on, then the value stored represents a negative input signal (less than 0V).

Channel Failure - The last diagnostic input can also indicate an analog channel failure. For example, if the 24VDC input power is missing or if the terminal block is loose, the module will turn on this input point and also returns a data value of zero (remember, if this input is on and the data value is not equal to zero, then it is just showing the sign).

The next section, Writing the Control Program, shows how these inputs can be used in a program.

Module Resolution

Since the module has 12-bit unipolar resolution, the analog signal is converted into 4096 counts ranging from 0 - 4095 (2¹²). For example, with a 0–10 V scale, a 0V signal would be 0 and a 10V signal would be 4095. This is equivalent to a binary value of 0000 0000 0000 to 1111 1111 1111, or 000 to FFF hexadecimal. The diagram shows how this relates to the signal range.

Each count can also be expressed in terms of the signal level by using the equation shown.

Each count can also be expressed in terms of the signal level by using the equation shown.

The following table shows the smallest detectable signal change that will result in one LSB change in the data value for each input signal range.

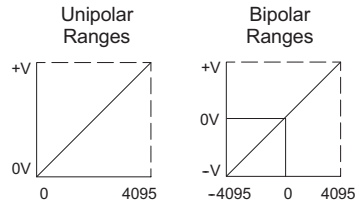

$$\text{Unipolar Resolution} = \frac{H - L}{4095}$$

$$\text{Bipolar Resolution} = \frac{H - L}{8191}$$

H or L = high or low limit of the range

Voltage Range	Signal Span (H-L)	Divide By	Smallest Detectable Change
0 to +10V	10V	4095	2.44 mV
-10V to +10V	20V	8191	2.44 mV
0 to +5V	5V	4095	1.22 mV
-5V to +5V	10V	8191	1.22 mV

Writing the Control Program

Reading Values: Pointer Method and Multiplexing

There are two methods of reading values:

- The pointer method
- Multiplexing

The multiplexing method must be used when using a D2-230 CPU. The multiplexing method must also be used with remote I/O modules (the pointer method will not work). Either method can be used with the D2-240, D2-250-1, D2-260 and D2-262 CPUs, but for ease of programming it is strongly recommended to use the pointer method.

Pointer Method for the D2-240, D2-250-1, D2-260 and D2-262 CPUs

The DL205 series has special V-memory locations assigned to each base slot that will greatly simplify the programming requirements. These V-memory locations allow you to:

- Specify the data format
- Specify the number of channels to scan
- Specify the storage locations.



NOTE: D2-250 CPUs with firmware release version 1.06 or later support this method. If the D2-230 example needs to be used, module placement in the base is very important. Review the section earlier in this chapter for guidelines.

The example program shows how to setup these locations. Place this rung anywhere in the ladder program, or in the initial stage if stage programming instructions are being used. This is all that is required to read the data into V-memory locations. Once the data is in V-memory, math can be used on the data, compare the data against preset values, and so forth. V2000 is used in the example but you can use any user V-memory location. In this example the module is installed in slot 2. Be sure to use the V-memory locations for the module placement. The pointer method automatically converts values to BCD (depending on the LD statement in the ladder logic).

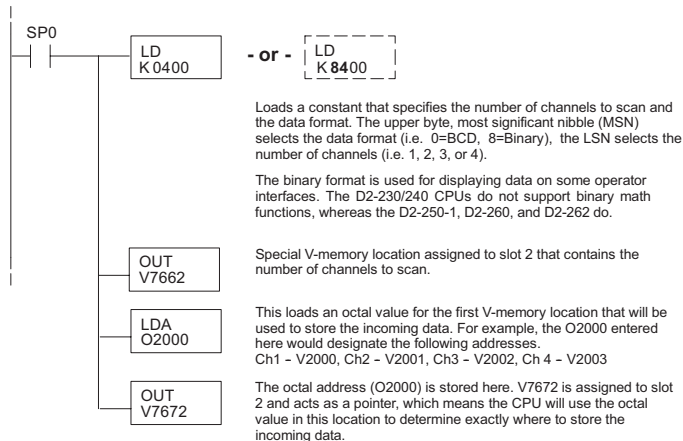

Chapter 3: F2-04AD-2 , F2-04AD-2L, 4-Channel Analog Voltage Input

The tables below show the special V-memory locations used by the D2-240, D2-250-1, D2-260 and D2-262 for the CPU base and local expansion base I/O slots. Slot 0 (zero) is the module next to the CPU or D2-CM module. Slot 1 is the module two places from the CPU or D2-CM, and so on. Remember, the CPU only examines the pointer values at these locations after a mode transition. Also, if you use the D2-230 (multiplexing) method, verify that these addresses in the CPU are zero.

The Table below applies to the D2-240, D2-250-1, D2-260 and D2-262 CPU base.

CPU Base: Analog Input Module Slot-Dependent V-memory Locations								
Slot	0	1	2	3	4	5	6	7
No. of Channels	V7660	V7661	V7662	V7663	V7664	V7665	V7666	V7667
Storage Pointer	V7670	V7671	V7672	V7673	V7674	V7675	V7676	V7677

The Table below applies to the D2-250-1, D2-260 or D2-262 CPU base 1.

Expansion Base D2-CM #1: Analog Input Module Slot-Dependent V-memory Locations								
Slot	0	1	2	3	4	5	6	7
No. of Channels	V36000	V36001	V36002	V36003	V36004	V36005	V36006	V36007
Storage Pointer	V36010	V36011	V36012	V36013	V36014	V36015	V36016	V36017

The Table below applies to the D2-250-1, D2-260 or D2-262 CPU base 2.

Expansion Base D2-CM #2: Analog Input Module Slot-Dependent V-memory Locations								
Slot	0	1	2	3	4	5	6	7
No. of Channels	V36100	V36101	V36102	V36103	V36104	V36105	V36106	V36107
Storage Pointer	V36110	V36111	V36112	V36113	V36114	V36115	V36116	V36117

The Table below applies to the D2-260 or D2-262 CPU base 3.

Expansion Base D2-CM #3: Analog Input Module Slot-Dependent V-memory Locations								
Slot	0	1	2	3	4	5	6	7
No. of Channels	V36200	V36201	V36202	V36203	V36204	V36205	V36206	V36207
Storage Pointer	V36210	V36211	V36212	V36213	V36214	V36215	V36216	V36217

The Table below applies to the D2-260 or D2-262 CPU base 4.

Expansion Base D2-CM #4: Analog Input Module Slot-Dependent V-memory Locations								
Slot	0	1	2	3	4	5	6	7
No. of Channels	V36300	V36301	V36302	V36303	V36304	V36305	V36306	V36307
Storage Pointer	V36310	V36311	V36312	V36313	V36314	V36315	V36316	V36317

Using Bipolar Ranges (Pointer Method) for D2-240, D2-250-1, D2-260 and D2-262 CPUs

Some additional logic is needed with bipolar ranges to determine whether the value being returned represents a positive voltage or a negative voltage. For example, the user may need to know the direction of a motor. With the D2-240, D2-250-1, D2-260, and D2-262 CPUs, the last input cannot be used to show the sign for each channel (X37 in the previous examples). This is because the pointer method reads all four channels in one scan. Therefore, if X37 were used, it would not be possible to determine if the first three channels returned negative voltage. Only the last channel can be checked to determine if it returned a negative voltage. A simple solution is to check if the returned value is greater than or equal to 8001. If it is greater than or equal to 8001 the returned value is negative.

The sign bit is the most significant bit, which combines 8000 with the data value. If the value is greater than or equal to 8001, only the most significant bit and the active channel bits will need to be masked to determine the actual data value.

The following program shows how to accomplish this. Since a negative value is always meant to be known, these rungs should be placed before any other operations that use the data, such as math instructions, scaling operations, and so forth. Also, if stage programming instructions are being used, place these rungs in a stage that is always active. Please note, this logic is only needed for each channel that is using bipolar input signals. The following example only shows two channels.

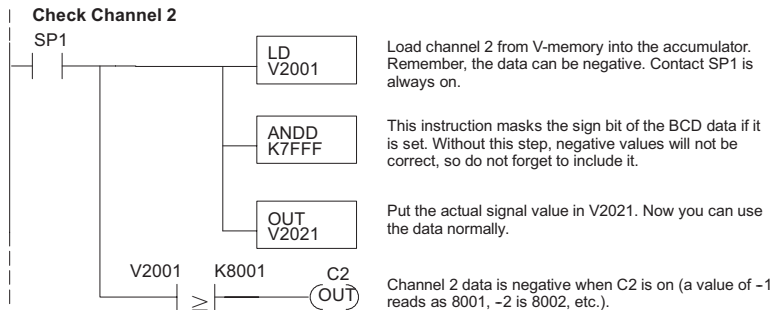
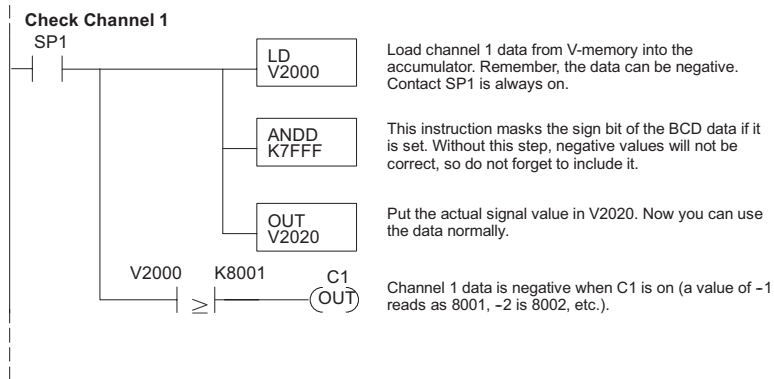

Reading Values (Multiplexing) for D2-230, D2-240, D2-250-1, D2-260 and D2-262 CPUs

The D2-230 CPU does not have the special V-memory locations which will allow data transfer to be automatically enabled. Since all channels are multiplexed into a single data word, the control program must be setup to determine which channel is being read. Since the module appears as 16 X input points to the CPU, it is very easy to use the active channel status bits to determine which channel is being monitored.



NOTE: This example is for a module installed as shown in the previous examples. The addresses used would be different if the module is installed in a different I/O arrangement. The rungs can be placed anywhere in the program, or if stage programming is being used, place them in a stage that is always active.

Load Data when Module is not busy

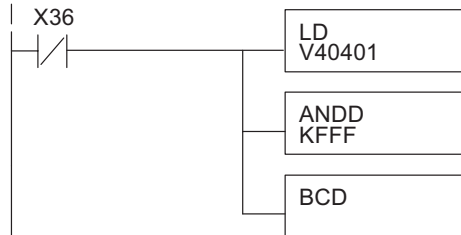

Loads the complete data word into the accumulator. The V-memory location depends on the I/O configuration. See Appendix A for the memory map.

This instruction masks the channel identification bits. Without this, the values used will not be correct so do not forget to include it.

It is usually easier to perform math operations in BCD, so it is best to convert the data to BCD immediately. You can leave out this instruction if your application does not require it.

Store Channel 1

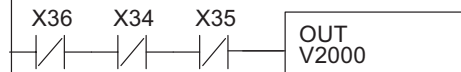

When the module is not busy and X34 and X35 are off, channel 1 data is stored in V2000.

Store Channel 2

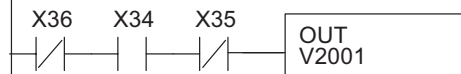

When X34 is on and X35 is off, channel 2 data is stored in V2001.

Store Channel 3

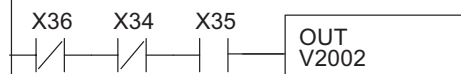

When X34 is off and X35 is on, channel 3 data is stored in V2002.

Store Channel 4

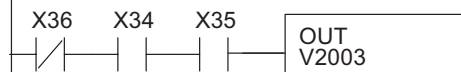

When both X34 and X35 are on, channel 4 data is stored in V2003.

Single Channel Selected

The single channel program makes it easy to determine which channel has been selected.

Store channel 1 when module is not busy.

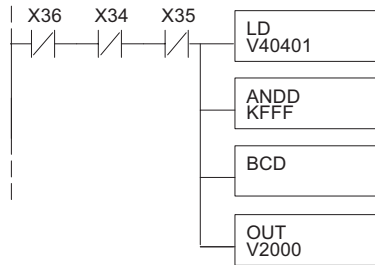

Loads the complete data word into the accumulator. The V-memory location depends on the I/O configuration. See Appendix A for the memory map.

This instruction masks the channel identification bits. Without this, the values used will not be correct, so do not forget to include it.

It is usually easier to perform math operations in BCD, so it is best to convert the data to BCD immediately. You can leave out this instruction if your application does not require it.

When the module is not busy and X34 and X35 are off, channel 1 data is stored in V2000.

Using Bipolar Ranges (Multiplexing)

Some additional logic is needed with bipolar ranges to determine whether the value being returned represents a positive voltage or a negative voltage. For example, the direction of a motor may be needed to be known. Since the D2-230 only reads one channel per scan, the last input can be used to show the sign (X37 in the examples).

The following program shows how to accomplish this. Since a negative value is always needed to be known, these rungs should be placed before any other operations that use the data, such as math instructions, scaling operations, and so forth. Also, if stage programming instructions are being used, place these rungs in a stage that is always active. Please note, this logic is only needed for each channel that is using bipolar input signals. The following example only shows two channels but the rungs can be repeated for all four channels if needed.

Load data when module is not busy.

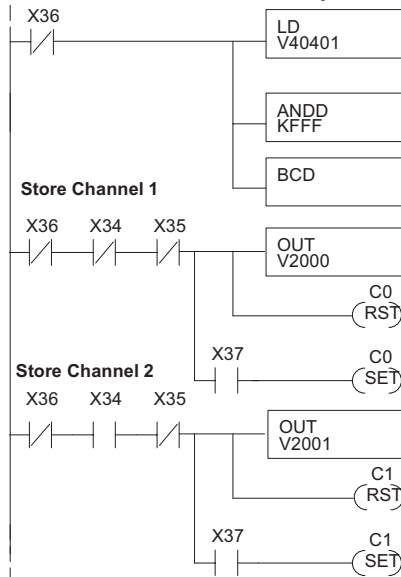

Loads the complete data word into the accumulator. The V-memory location depends on the I/O configuration. See Appendix A for the memory map.

This instruction masks the channel identification bits. Without this, the values used will not be correct, so do not forget to include it.

It is usually easier to perform math operations in BCD, so it is best to convert the data to BCD immediately. You can leave out this instruction if your application does not require it.

When the module is not busy and X34 and X35 are off, channel 1 data is stored in V2000. C0 is reset to indicate channel one's value is positive.

If X37 is on, then the data value represents a negative voltage. C0 is set to indicate channel 1's value is negative.

When the module is not busy, and X34 is on and X35 is off, channel 2 data is stored in V2001. C1 is reset to indicate that channel 2's value is positive.

If X37 is on, then the data value represents a negative voltage. C1 is set to indicate that channel 2's value is negative.

Using 2's Complement (Multiplexing) for D2-230, D2-240, D2-250-1, D2-260 and D2-262 CPUs

The 2's complement data format may be required to display negative values on some operator interface devices. It could also be used to simplify data averaging on bipolar signals.

The example shows two channels, but these steps can be repeated for all four channels if necessary.

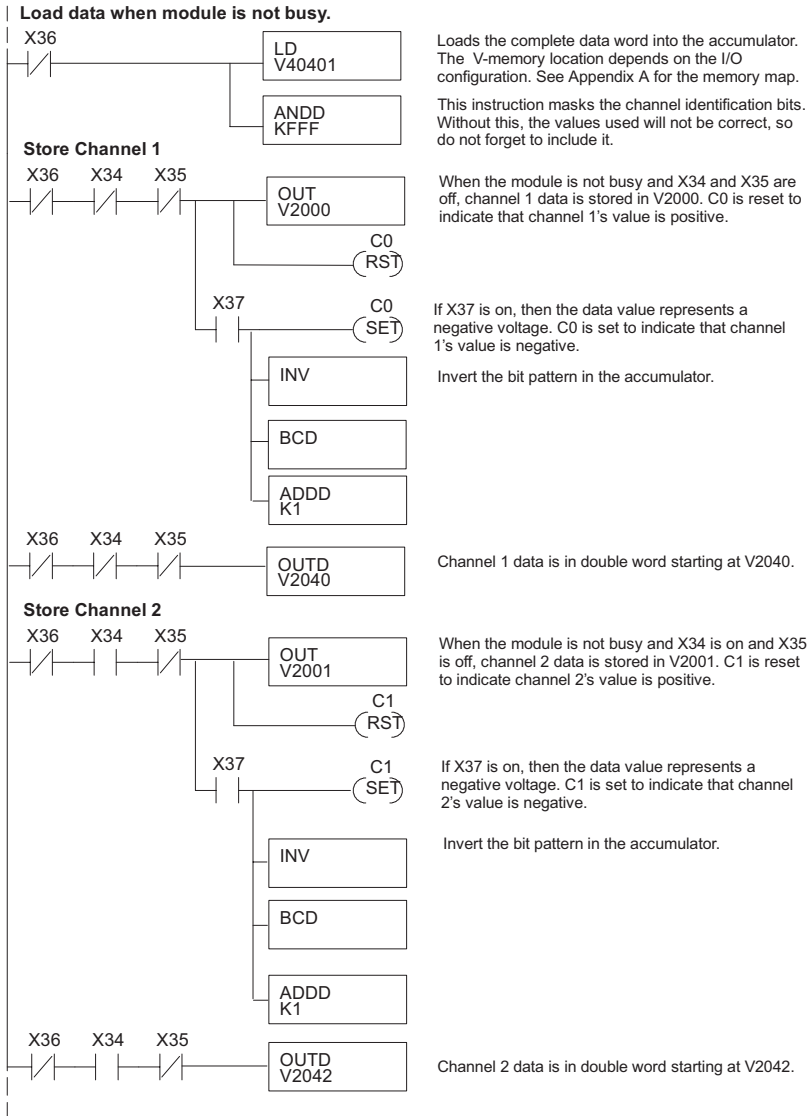

Analog Power Failure Detection

The analog module has a microcontroller which can diagnose analog input circuit problems. A ladder rung can be added to program to detect these problems. This rung shows an input point that would be assigned if the module was used as shown in the previous examples. A different point would be used if the module was installed in a different I/O configuration.

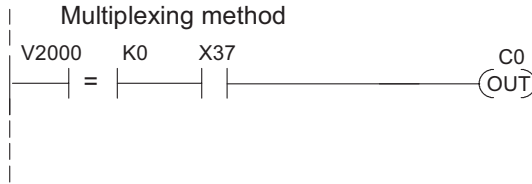

V-memory location V2000 holds channel 1 data. When a data value of zero is returned and input X37 is on, then the analog circuitry is not operating properly.

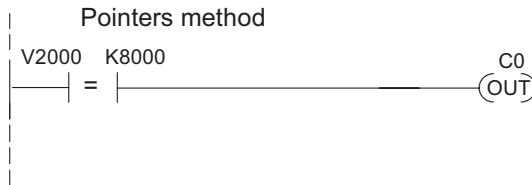

V-memory location V2000 holds channel 1 data. When a data value of 8000 is returned, then the analog circuitry is not operating properly.

Scaling the Input Data

Most applications usually require measurements in engineering units which provides more meaningful data. This is accomplished by using the conversion formula shown.

Adjustments may be needed to the formula depending on the scale being used for the engineering units.

For example, if pressure (psi) is to be measured from 0.0–99.9 then multiply the value by 10 in order to imply a decimal place when viewing the value with the programming software or with a handheld programmer. Notice how the calculations differ when the multiplier is used.

$$\text{Units} = A \frac{H - L}{4095}$$

U = Engineering Units

A = Analog Value (0 – 4095)

H = High limit of the engineering unit range

L = Low limit of the engineering unit range

An analog value of 2024, slightly less than half scale, should yield 49.4 psi.

Example without multiplier

$$\begin{aligned} \text{Units} &= A \frac{H - L}{4095} \\ \text{Units} &= 2024 \frac{100 - 0}{4095} \\ \text{Units} &= 49 \end{aligned}$$

Example with multiplier

$$\begin{aligned} \text{Units} &= 10A \frac{H - L}{4095} \\ \text{Units} &= 20240 \frac{100 - 0}{4095} \\ \text{Units} &= 494 \end{aligned}$$

The Conversion Program

The following example shows how to write the program to perform the engineering unit conversion from input data formats 0–4095. This example assumes the raw input data read at V2000 is in BCD format.



NOTE: This example uses SP1, which is always on, but any permissive contact such as X, C, etc., can be used.

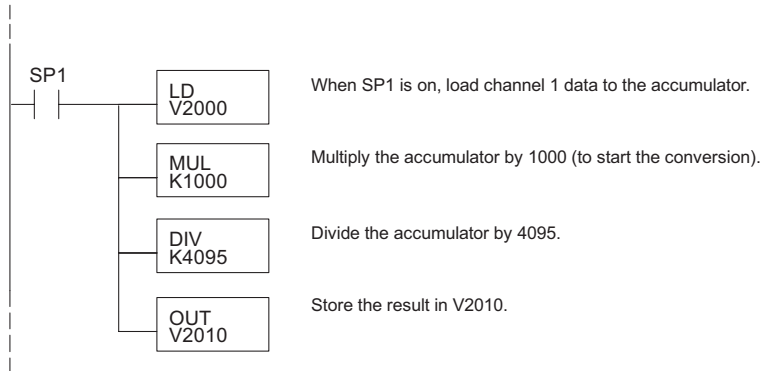

Analog and Digital Value Conversions

Sometimes it is useful to be able to quickly convert between the signal levels and the digital values. This is especially helpful during machine startup or troubleshooting. Remember, that this module does not operate like other versions of analog input modules. The bipolar ranges use 0–4095 for both positive and negative voltages. The sign bit allows this, which actually provides better resolution than those modules that do not offer a sign bit. The following table provides formulas to make this conversion easier.

Range	If the digital value is known	If the analog signal level is known.
0–5V –5V to +5V	$A = 5D$ 4095	$D = 4095(A)$ 5
0–0V –10V to +10V	$A = 5D$ 4095	$D = 4095 \text{ ABS}(A)$ 10

As an example, if the range being used is $\pm 10V$ and the measured signal is 6V, use the formula to the right to determine the digital value that is stored in the V-memory location that contains the data.

$$D = 4095(A)$$

$$D = 4095(6V)$$

$$D = (409.5)(6)$$

$$D = 2457$$

Filtering Input Noise for D2-250-1, D2-260 and D2-262 CPUs

Add the following logic to filter and smooth analog input noise in D2-250-1, D2-260 and D2-262 CPUs. This is especially useful when using PID loops. Noise can be generated by the field device and or induced by field wiring.

In the following example, the analog value in BCD is first converted to a binary number. Memory location V1400 is the designated work space in this example. The MULR instruction is the filter factor, which can be from 0.1–0.9. The example uses 0.2. Using a smaller filter factor increases filtering. A higher precision value can be used, but it is not generally needed. The filtered value is then converted back to binary and then to BCD. The filtered value is stored in location V1402 for use in your application or PID loop.



NOTE: Please review intelligent instructions (IBox) in Chapter 5 of D2-USER-M, which simplify this and other functions. The IBox instructions are supported by the D2-250-1, D2-260 and D2-262.

NOTE: Be careful not to do a multiple number conversion on a value. For example, if you are using the pointer method to get the analog value, it is in BCD and must be converted to binary. However, if you are using the conventional method of reading analog and are masking the first twelve bits, then it is already in binary and no conversion using the BIN instruction is needed.

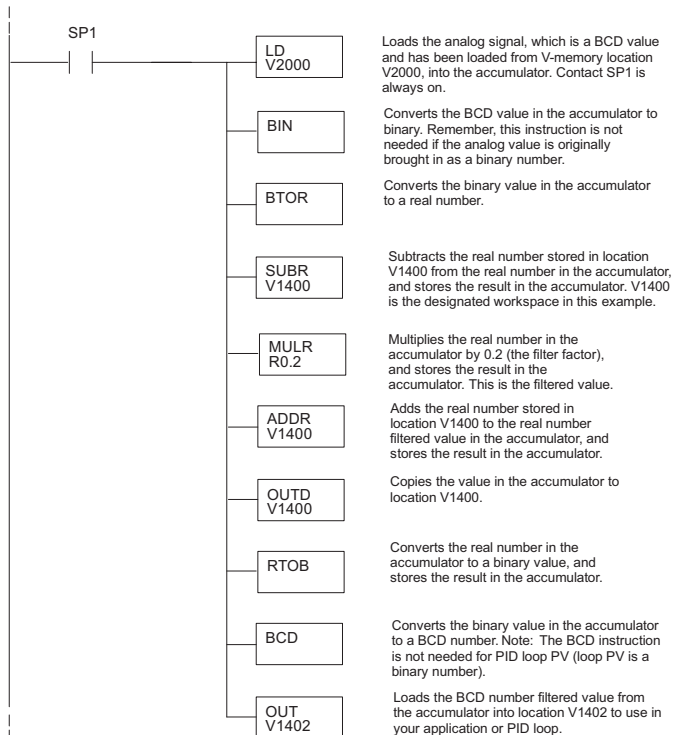

F2-08AD-1, 8-CHANNEL ANALOG CURRENT INPUT



In This Chapter...

Module Specifications	4-2
Setting the Module Jumpers	4-5
Connecting the Field Wiring.....	4-6
Module Operation.....	4-9
Writing the Control Program.....	4-13

Module Specifications



NOTE: A re-designed F2-08AD-1 with a single circuit board design was released in 2009. The jumper link location is different. See *Setting the Module Jumpers* on page 4-6. Also, some specifications were changed on page 4-3. Otherwise, the re-designed module functions the same as the prior design.

The F2-08AD-1 Analog Input module provides several hardware features:

- Analog inputs are optically isolated from the PLC logic.
- On-board 250 ohm, 1/2 Watt precision resistors provide substantial over-current-protection for 4-20mA current loops.
- The module has a removable terminal block so the module can be easily removed or changed without disconnecting the wiring.
- With a D2-240, D2-250-1, D2-260 or D2-262 CPU, you can read all channels in one scan.

Firmware Requirements:

To use this module with a D2-230 CPU the CPU must have firmware version 1.6 or later. To use the pointer method of writing values, D2-240 CPUs require firmware version 2.2 or later. All versions of the D2-250-1, D2-260 and D2-262 CPU's firmware support this module and the pointer method.

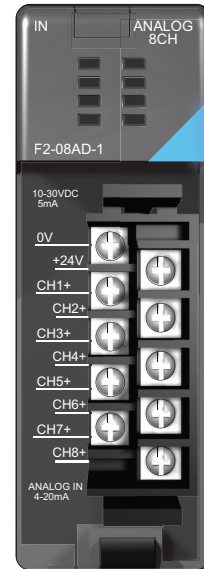

F2-08AD-1

Analog Input Configuration Requirements

The F2-08AD-1 appears as a 16-point discrete input module and can be installed in any slot of a DL205 system. The available power budget and discrete I/O points are the limiting factors. For more information regarding power budget and number of local, local expansion or remote I/O points, check the user manual for the particular CPU model and I/O base being used

Chapter 4: F2-08AD-1, 8-Channel Analog Current Input

The following tables provide the specifications for the F2-08AD-1 Analog Input Module. Review these specifications to make sure the module meets your application requirements.

Input Specifications	
Number of Channels	8, single ended (one common)
Input Range	4–20 mA, current
Resolution	12 bit (1 in 4096)
Step Response	1ms (*7ms) to 95% of full step change
Crosstalk	-70db, 1 count maximum
Active Low-pass Filtering	-3db at 200Hz, (-6db per octave)
Input Impedance	250MΩ ±0.1%, 1/2 W current input
Absolute Maximum Ratings	-45mA to + 45mA, current input
Linearity Error (End to End)	± 1 count (0.025% of full scale) maximum
Input Stability	± 1 count
Full Scale Calibration Error (Offset error included)	± 5 counts maximum @ 20.000 mA
Offset Calibration Error	± 2 count maximum @ 4.000 mA
Maximum Inaccuracy	± 0.1% @ 25°C (77°F) ± 0.25% 0–60°C (32–140°F)
Accuracy vs. Temperature	± 50ppm / °C full scale calibration change (including maximum offset change)
Recommended Fuse (external)	0.032 A, Series 217 fast-acting, current inputs

General Specifications	
PLC Update Rate	1 channel per scan maximum (D2-230 CPU) 8 channels per scan maximum (D2-240, D2-250-1, D2-260 and D2-262 CPU)
Data Acquisition Time	3ms / channel (asynchronous)
Digital Inputs Input points required	12 binary data bits, 3 channel ID bits, 1 broken transmitter detection bit 16 point (X) input module
Power Budget Requirement	100mA (*50mA maximum, 5VDC (supplied by base)
External Power Supply	5mA maximum, 10–30 VDC (*80mA max, 18–26.4 VDC)
Operating Temperature	0°C to 60°C (32°F to 140° F)
Storage Temperature	-20°C to 70°C (-4°F to 158°F)
Relative Humidity	5–95% (non-condensing)
Environmental Air	No corrosive gases permitted
Vibration	MIL STD 810C 514.2
Shock	MIL STD 810C 516.2
Noise Immunity	NEMA ICS3-304



NOTE: Values in parenthesis with an **asterisk** are for older modules with two circuit board design and date codes 0609B5 or previous. Values not in parenthesis are for single circuit board models with date code 0709C1 or above.

Special Placement Requirements (D2-230 and Remote I/O Bases)

Even though the module can be placed in any slot, it is important to examine the configuration if a D2-230 CPU is used, as can be seen in the section about Writing the Program located in this chapter. V-memory locations are used to extract the analog data. If the module is placed so the input points do not start on a V-memory boundary, the instructions cannot access the data. This also applies when placing this module in a remote base using a D2-RSSS in the CPU slot.

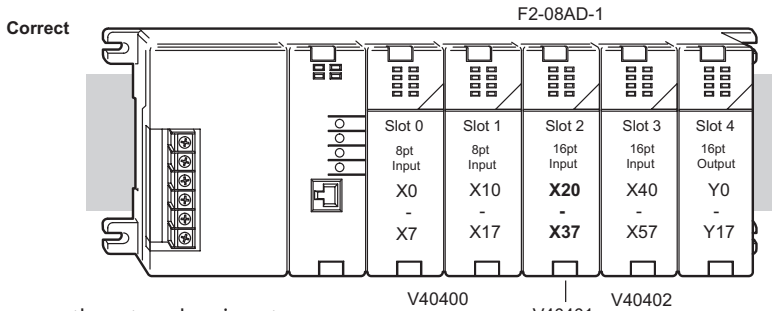

Data is correctly entered so input points start on a V-memory boundary.

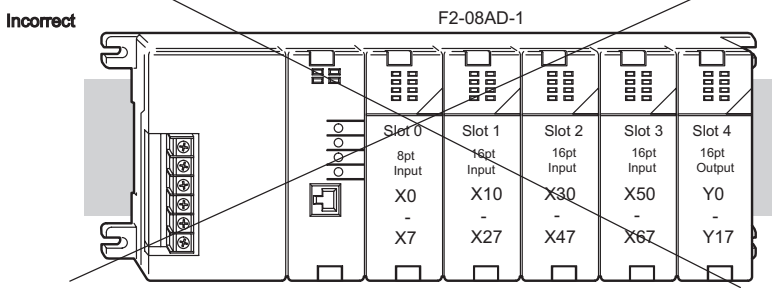
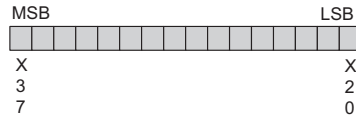

Data is split over two locations, so instructions cannot access data from a D2-230.

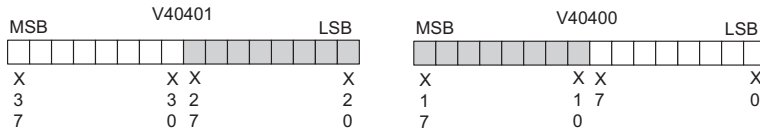

To use the V-memory references required for a D2-230 CPU, the first input address assigned to the module must be one of the following X locations. The table also shows the V-memory addresses that correspond to these X locations.

X	X0	X20	X40	X60	X100	X120	X140	X160
V	V40400	V40401	V40402	V40403	V40404	V40405	V40406	V40407

Setting the Module Jumpers

Selecting the Number of Channels

There are two jumpers, labeled +1, +2, and +4 which are used to select the number of channels that will be used. Use the figures below to locate the jumpers on the module. The module is set from the factory for eight channel operation (all three jumpers installed).

The unused channels are not processed, so if only channels 1 thru 3 are selected, channels 4 through 8 will not be active. The following table shows how to use the jumpers to select the number of channels.

No. of Channels	+1	+2	+4
1	No	No	No
1,2	Yes	No	No
1,2,3	No	Yes	No
1,2,3,4	Yes	Yes	No
1,2,3,4,5	No	No	Yes
1,2,3,4,5,6	Yes	No	Yes
1,2,3,4,5,6,7	No	Yes	Yes
1,2,3,4,5,6,7,8	Yes	Yes	Yes

Yes = jumper installed

No = jumper removed

For example, to select all 8-channel operation, leave three jumpers installed. To select channel 1, remove (or store on a single post to prevent losing them) all three jumpers

Jumper location on modules having date code 0609B9 and previous (two circuit board design)

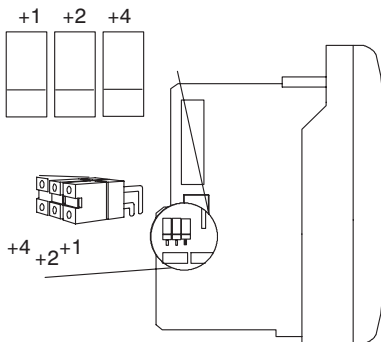

These jumpers are located on the motherboard, the one with the black D-shell style backplane connector.

Jumper location on modules having date code 0709C1 and above (single circuit board design)

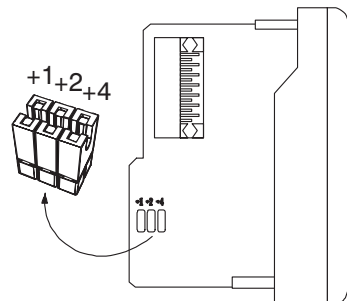

Connecting the Field Wiring

Wiring Guidelines

Your company may have guidelines for wiring and cable installation. If so, check them before starting the installation. Here are some general things to consider:

- Use the shortest wiring route whenever possible.
- Use shielded wiring and ground the shield at the transmitter source. Do not ground the shield at both the module and the source.
- Do not run the signal wiring next to large motors, high current switches, or transformers. This may cause noise problems.
- Route the wiring through an approved cable housing to minimize the risk of accidental damage. Check local and national codes to choose the correct method for your application.

User Power Supply Requirements

The F2-08AD-1 module requires at least one field-side power supply. The same or separate power sources can be used for the module supply and the current transmitter supply. The module requires 10–30 VDC, at 5mA, from the external power supply.

The DL205 AC bases have a built-in 24VDC power supply that provide up to 300mA of current. This can be used instead of a separate supply. Check the power budget to be safe.

It is desirable in some situations to power the transmitters separately in a location remote from the PLC. This will work as long as the transmitter supply meets the voltage and current requirements, and the transmitter and module supply minus (-) side are connected together.



WARNING: If using the 24VDC base power supply, make sure to calculate the power budget. Exceeding the power budget can cause unpredictable system operation that can lead to a risk of personal injury or damage to equipment.

The DL205 base has a switching type power supply. As a result of switching noise, ± 3 –5 counts of instability may be noticed in the analog input data if the base power supply is used. If this is unacceptable, try one of the following:

1. Use a separate linear power supply.
2. Connect the 24VDC common to the frame ground, which is the screw terminal marked on the screw terminal marked "G" on the base.

By using these methods, the input stability is rated at ± 1 count.

Current Loop Transmitter Impedance

Standard 4–20 mA transmitters and transducers can operate from a wide variety of power supplies. Not all transmitters are alike and the manufacturers often specify a minimum loop or load resistance that must be used with the transmitter.

The F2-08AD-1 provides 250Ω resistance for each channel. If the transmitter being used requires a load resistance below 250Ω, it will not be necessary to make any adjustments. However, if the transmitter requires a load resistance higher than 250Ω, a resistor will need to be added in series with the input.

Consider the following example for a transmitter being operated from a 30VDC supply with a recommended load resistance of 750Ω. Since the module has a 250Ω resistor, an additional resistor needs to be added.

$$R = Tr - Mr$$

$$R = 750 - 250$$

$$R \geq 500$$

R - Resistor to add
Tr - Transmitter Requirement
Mr - Module resistance (internal 250Ω)

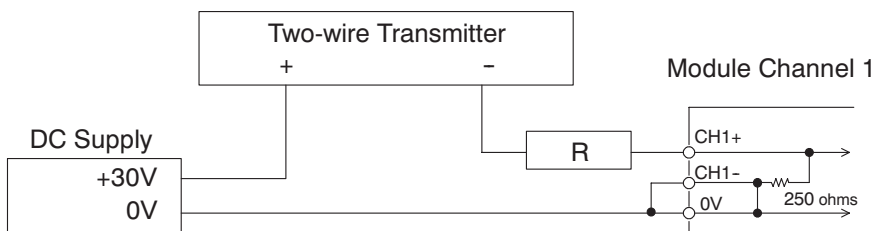

Wiring Diagram

The F2-08AD-1 module has a removable connector to simplify wiring the module. Just squeeze the top and bottom retaining clips and gently pull the connector from the module. Use the following diagram to connect the field wiring.

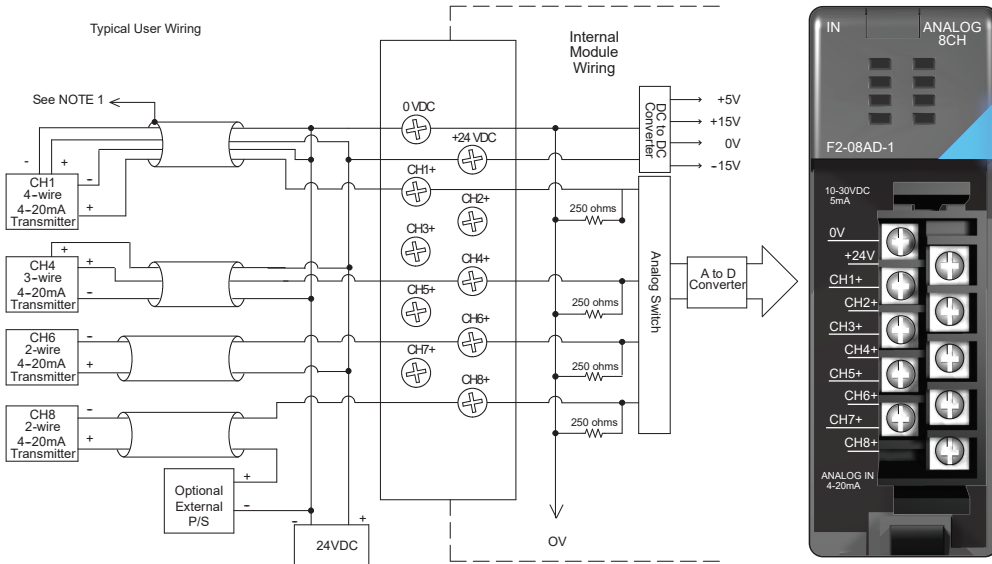

NOTE 1: Shields should be grounded at the signal source.

NOTE 2: More than one external power supply can be used, provided all the power supply commons are connected.

NOTE 3: A Series 217, 0.032A fast-acting fuse is recommended for 4-20 mA current loops.

NOTE 4: If the power supply common of an external power supply is not connected to 0 VDC on the module, then the output of the external transmitter must be isolated. To avoid "ground loop" errors, recommended 4-20 mA transmitter types are:

2 or 3 wire: Isolation between input signal and power supply.

4 wire: Isolation between input signal, power supply, and 4-20 mA output.

Module Operation

Channel Scanning Sequence (Multiplexing) for a D2-230 CPU

Before beginning to write the control program, it is important to take a few minutes to understand how the module processes and represents the analog signals.

The F2-08AD-1 can supply different amounts of data per scan, depending on the type of CPU being used. The D2-230 can obtain one channel of data per CPU scan. Since there are eight channels, it can take up to eight scans to get data for all channels. Once all channels have been scanned the process starts over with channel 1. Unused channels are not processed, so if only two channels are selected, then each channel will be updated every other scan. The multiplexing method can also be used for the D2-240, D2-250-1, D2-260 and D2-262 CPUs.

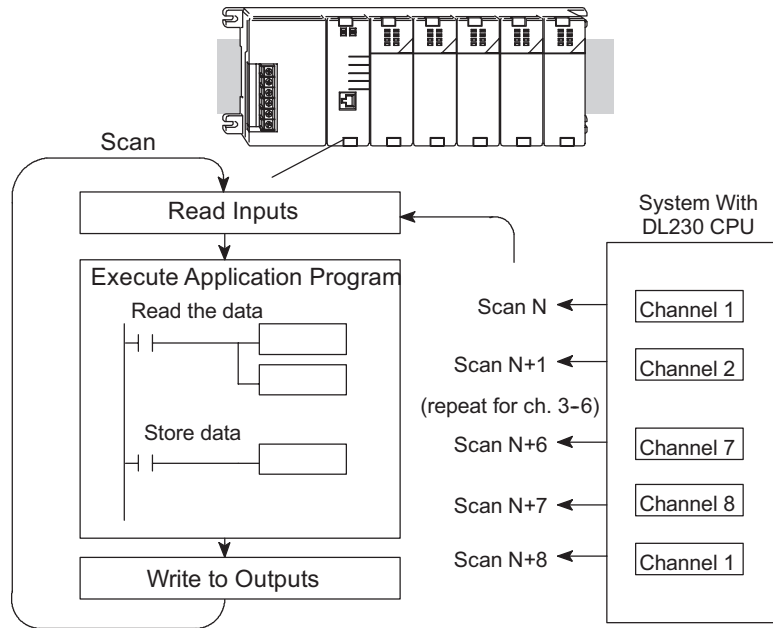

Channel Scanning Sequence (Pointer method) for D2-240, D2-250-1, D2-260 or D2-262 CPUs

If a D2-240, D2-250-1, D2-260 or a D2-262 CPU is used, all four channels of input data can be collected in one scan. This is because the D2-240, D2-250-1, D2-260 and D2-262 CPUs supports special V-memory locations that are used to manage the data transfer. This is discussed in more detail in the section on Writing the Control Program later in this chapter.

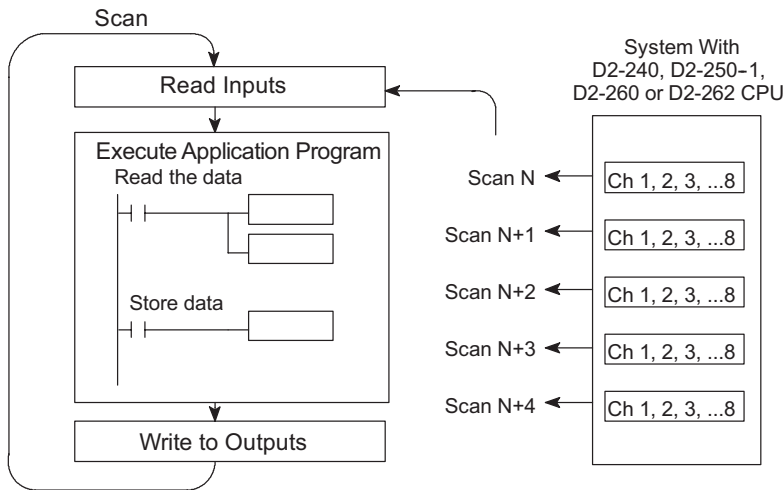

Analog Module Updates

Even though the channel updates to the CPU are synchronous with the CPU scan, the module asynchronously monitors the analog transmitter signal and converts the signal to a 12-bit binary representation. This enables the module to continuously provide accurate measurements without slowing down the discrete control logic in the RLL program.

For the vast majority of applications, the values are updated much faster than the signal changes. However, in some applications, the update time can be important. The module takes approximately one millisecond to sense 95% of the change in the analog signal.



NOTE: This is not the amount of time required to convert the signal to a digital representation. The conversion to the digital representation takes only a few microseconds. Many manufacturers list the conversion time, but it is the settling time of the filter that really determines the update time.

Understanding the Input Assignments

It was mentioned earlier in this chapter that the F2-08AD-1 module appears as a 16-point discrete input module to the CPU. These points can be used to obtain:

- An indication of which channel is active
- The digital representation of the analog signal
- Module diagnostic information

Since all input points are automatically mapped into V-memory, it is very easy to determine the location of the data word that will be assigned to the module.

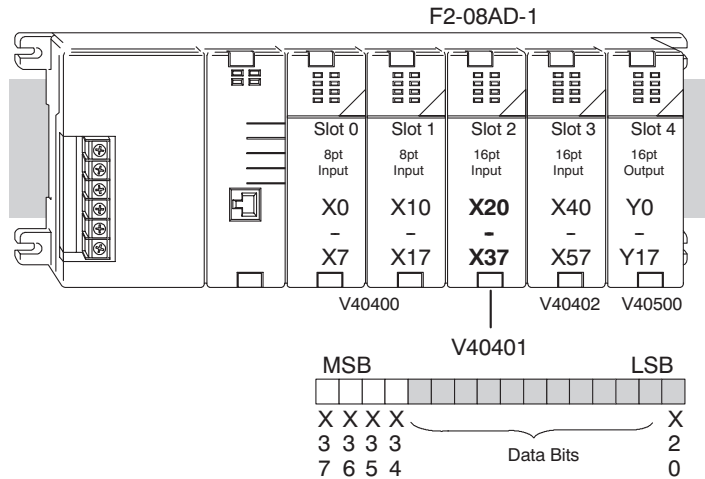

Within these word locations, the individual bits represent specific information about the analog signal.

Analog Data Bits

The first twelve bits represent the analog data in binary format.

Bit	Value	Bit	Value
0	1	6	64
1	2	7	128
2	4	8	256
3	8	9	512
4	16	10	1024
5	32	11	2048

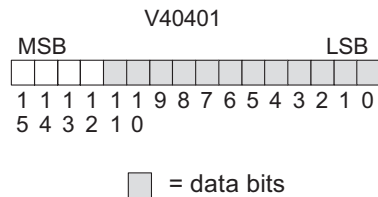

Active Channel Indicator Inputs

Three of the inputs are binary-encoded to indicate the active channel (remember, the V-memory bits are mapped directly to discrete inputs). The inputs are automatically turned on and off to indicate the active channel for each scan.

Scan	X34	X35	X36	Channel
N	Off	Off	Off	1
N+1	On	Off	Off	2
N+2	Off	On	Off	3
N+3	On	On	Off	4
N+4	Off	Off	On	5
N+5	On	Off	On	6
N+6	Off	On	On	7
N+7	On	On	On	8



Module Diagnostic Inputs

The last input (X37 in this example) is the broken transmitter and missing 24 volts input power indicator.

When X37 is on, the input transmitter may be broken for the corresponding input. If there is no external 24 volts input power, or if there is a loose or missing terminal block, then X37 goes on and a value of zero is returned for all enabled channels.

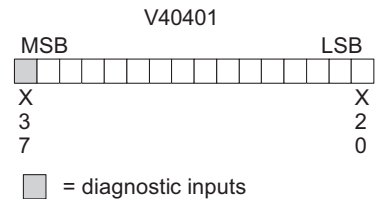

Module Resolution

Since the module has 12-bit resolution, the analog signal is converted into 4096 counts ranging from 0 - 4095 (2¹²). For example, a 4 mA signal would be 0 and a 20 mA signal would be 4095. This is equivalent to a binary value of 0000 0000 0000 to 1111 1111 1111, or 000 to FFF hexadecimal. The diagram shows how this relates to the signal range.

Each count can also be expressed in terms of the signal level by using the equation shown.

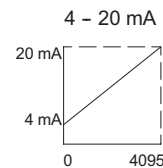

$$\text{Resolution} = \frac{H - L}{4095}$$

H = high limit of the signal range

L = low limit of the signal range

$$16 \text{ mA} / 4095 = 3.907 \text{ } \mu\text{A per count}$$

Writing the Control Program

Reading Values: Pointer Method and Multiplexing

There are two methods which can be used to read values:

- Pointer method
- Multiplexing

The multiplexing method must be used when using a D2-230 CPU. The multiplexing method must also be used with remote I/O modules (the pointer method will not work). Either method can be used with the D2-240, D2-250-1, D2-260 and D2-262 CPUs, but for ease of programming it is strongly recommended to use the pointer method.

Pointer Method for D2-240, D2-250-1, D2-260 and D2-262 CPUs

The DL205 series has special V-memory locations (shown in tables on the following page) assigned to each base slot that will greatly simplify the programming requirements. These V-memory locations allow you to:

- Specify the data format
- Specify the number of channels to scan
- Specify the storage locations



NOTE: D2-240 CPUs with firmware release version 2.2 or later support this method. Also, D2-250 CPUs with firmware release version 1.06 or later support this method. If the D2-230 example needs to be used, module placement in the base is very important. Review the section earlier in this chapter for guidelines.

The example program shows how to setup these locations. Place this rung anywhere in the ladder program, or, if RLLPLUS instructions are being used, in the Initial Stage.

This is all that is required to read the analog data into V-memory locations. Once the data is in V-memory, it can be used to perform math, compare the data against preset values, etc. V2000 is used in the example but any user V-memory location can be used. The pointer method automatically converts values to BCD.

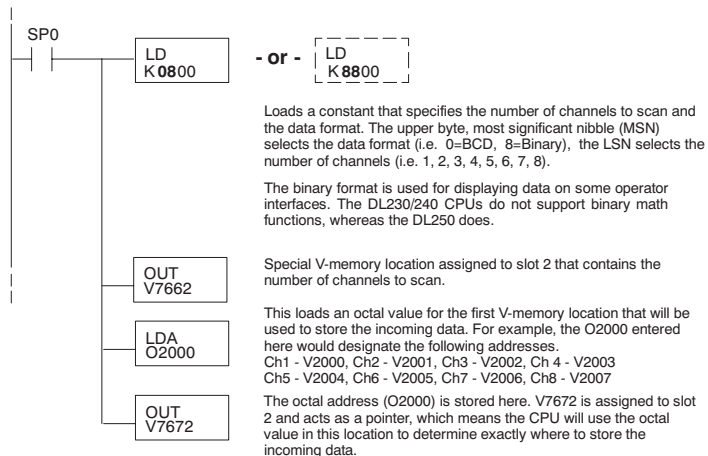

The tables below show the special V-memory locations used by the D2-240, D2-250-1, D2-260 and D2-262 for the CPU base and local expansion base I/O slots. Slot 0 (zero) is the module next to the CPU or the D2-CM module. Slot 1 is the module two places from the CPU or the D2-CM, and so on. Remember, the CPU only examines the pointer values at these locations after a mode transition. Also, if the D2-230 (multiplexing) method is used, verify that these addresses in the CPU are zero.

The table below applies to the D2-240, D2-250-1, D2-260 and D2-262 CPU base.

CPU Base: Analog Input Module Slot-Dependent V-memory Locations								
Slot	0	1	2	3	4	5	6	7
No. of Channels	V7660	V7661	V7662	V7663	V7664	V7665	V7666	V7667
Storage Pointer	V7670	V7671	V7672	V7673	V7674	V7675	V7676	V7677

The table below applies to the D2-250-1, D2-260 or the D2-262 expansion base 1.

Expansion Base D2-CM #1: Analog Input Module Slot-Dependent V-memory Locations								
Slot	0	1	2	3	4	5	6	7
No. of Channels	V36000	V36001	V36002	V36003	V36004	V36005	V36006	V36007
Storage Pointer	V36010	V36011	V36012	V36013	V36014	V36015	V36016	V36017

The table below applies to the D2-250-1, D2-260 or the D2-262 expansion base 2.

Expansion Base D2-CM #2: Analog Input Module Slot-Dependent V-memory Locations								
Slot	0	1	2	3	4	5	6	7
No. of Channels	V36100	V36101	V36102	V36103	V36104	V36105	V36106	V36107
Storage Pointer	V36110	V36111	V36112	V36113	V36114	V36115	V36116	V36117

The table below applies to the D2-260 and D2-262 CPU expansion base 3.

Expansion Base D2-CM #3: Analog Input Module Slot-Dependent V-memory Locations								
Slot	0	1	2	3	4	5	6	7
No. of Channels	V36200	V36201	V36202	V36203	V36204	V36205	V36206	V36207
Storage Pointer	V36210	V36211	V36212	V36213	V36214	V36215	V36216	V36217

The table below applies to the D2-260 and D2-262 CPU expansion base 4.

Expansion Base D2-CM #4: Analog Input Module Slot-Dependent V-memory Locations								
Slot	0	1	2	3	4	5	6	7
No. of Channels	V36300	V36301	V36302	V36303	V36304	V36305	V36306	V36307
Storage Pointer	V36310	V36311	V36312	V36313	V36314	V36315	V36316	V36317

Reading Values (Multiplexing) for D2-230, D2-240, D2-250-1, D2-260 and D2-262 CPUs

The D2-230 CPU does not have the special V-memory locations which will allow data transfer to be automatically enabled. Since all channels are multiplexed into a single data word, the control program must be setup to determine which channel is being read. Since the module appears as X input points to the CPU, it is very easy to use the active channel status bits to determine which channel is being monitored.



NOTE: This example is for a module installed as shown in the previous examples. The addresses used would be different if the module was installed in a different I/O arrangement. The rungs can be placed anywhere in the program, or if stage programming is being used, place them in a stage that is always active.

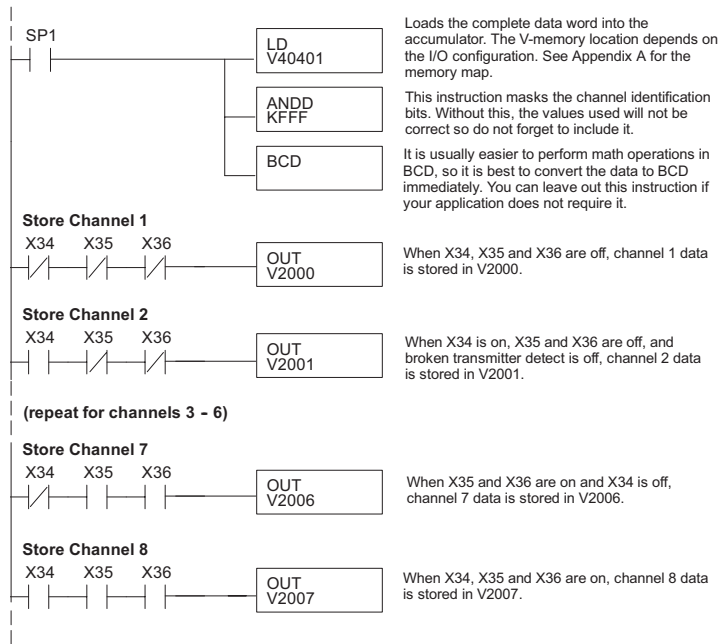

Single Channel Selected

Since it isn't necessary to know which channel is selected, the single channel program is even more simple as shown in the example below.

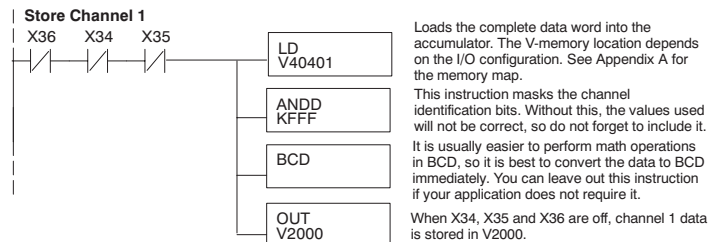

Analog Power Failure Detection

The Analog module has an on-board processor that can diagnose analog input circuit problems. A ladder rung can be edited to detect these problems. This rung shows an input point that would be assigned if the module was installed as shown in the previous examples. A different point would be used if the module was installed in a different I/O arrangement.

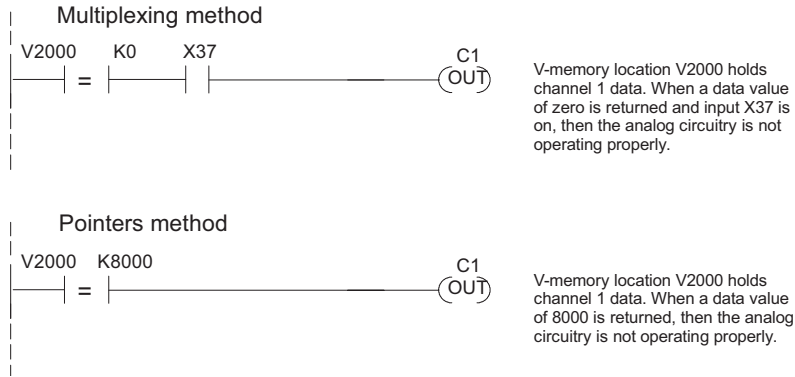

Scaling the Input Data

Most applications usually require measurements in engineering units which provides more meaningful data. This is accomplished by using the conversion formula shown.

Adjustments to the formula may be needed depending on the scale being used for the engineering units.

For example, if pressure (psi) is to be measured from 0.0 to 99.9 then multiply the value by 10 in order to imply a decimal place when viewing the value with the programming software or with a handheld programmer. Notice how the calculations differ when the multiplier is used.

$$\text{Units} = \frac{A}{4095} (H - L)$$

U = Engineering Units
 A = Analog Value (0 – 4095)
 H = High limit of the engineering unit range
 L = Low limit of the engineering unit range

Analog Value of 2024, slightly less than half scale, should yield 49.4 psi.

Example without multiplier

$$\text{Units} = \frac{A}{4095} (H - L)$$

$$\text{Units} = \frac{2024}{4095} (100 - 0)$$

$$\text{Units} = 49$$

Example with multiplier

$$\text{Units} = \frac{10A}{4095} (H - L)$$

$$\text{Units} = \frac{20240}{4095} (100 - 0)$$

$$\text{Units} = 494$$

The Conversion Program

The following example shows how to write the program to perform the engineering unit conversion. This example assumes that the data is in BCD and loaded into the appropriate V-memory locations using instructions that apply to the CPU being used in the PLC.



NOTE: This example uses SP1, which is always on, but any permissive contact such as X, C, etc., can be used.

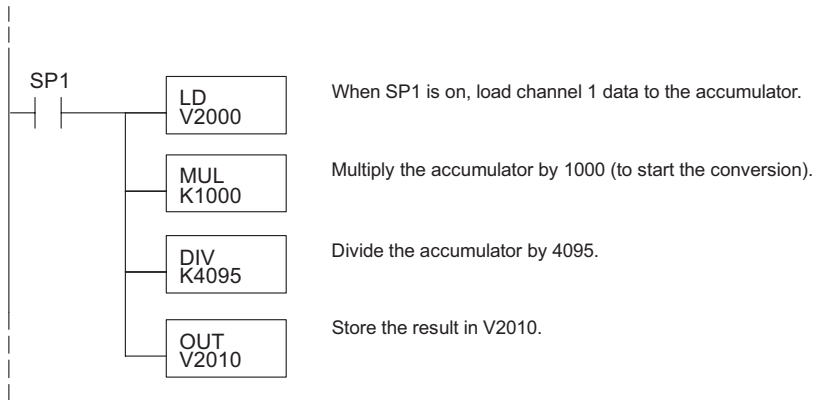

Analog and Digital Value Conversions

Sometimes it is useful to be able to quickly convert between the signal levels and the digital values. This is especially helpful during machine startup or troubleshooting. The following table provides formulas to make this conversion more simple.

Range	If the digital value is known	If the analog signal level is known.
4 to 20 mA	$A = 16D + 4$ 4095	$D = \frac{4095(A - 4)}{16}$

As an example, if the measured signal is 10mA, the formula can be used to easily determine the digital value that will be stored in the V-memory location that contains the data.

$$D = \frac{4095}{16}(A - 4)$$

$$D = \frac{4095}{16}(6V)$$

$$D = (409.5)(6)$$

$$D = 2457$$

Filtering Input Noise for D2-250-1, D2-260 and D2-262 CPUs

Add the following logic to filter and smooth analog input noise in D2-250-1, D2-260 and D2-262 CPUs. This is especially useful when using PID loops. Noise can be generated by the field device and/or induced by field wiring.

In the following example, the analog value in BCD is first converted to a binary number. Memory location V1400 is the designated work space in this example. The MULR instruction is the filter factor, which can be from 0.1 to 0.9. The example uses 0.2. A smaller filter factor increases filtering. A higher precision value can be used, but it is not generally needed. The filtered value is then converted back to binary and then to BCD. The filtered value is stored in location V1402 for use in your application or PID loop.



NOTE: Please review intelligent instructions (IBox) in Chapter 5 of D2-USER-M, which simplify this and other functions. The IBox instructions are supported by the D2-250-1, D2-260 and D2-262.

NOTE: Be careful not to do a multiple number conversion on a value. For example, if the pointer method is used to get the analog value, it is in BCD and must be converted to binary. However, if the conventional method of reading analog is used and the first twelve bits are masked, then it is already in binary and no conversion using the BIN instruction is needed.

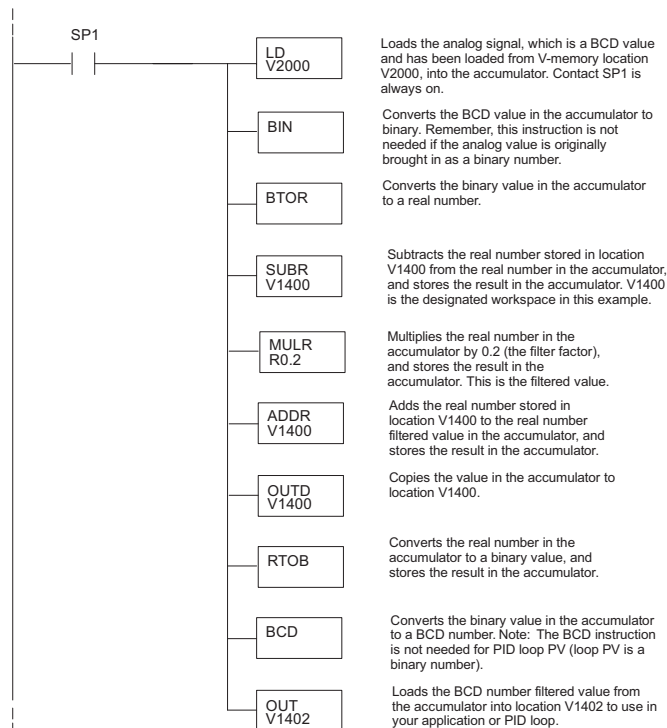

F2-08AD-2 8-CHANNEL ANALOG VOLTAGE INPUT



In This Chapter...

Module Specifications	5-2
Setting the Module Jumpers	5-5
Connecting the Field Wiring	5-7
Module Operation	5-9
Writing the Control Program.....	5-14

Module Specifications



NOTE: A re-designed F2-08AD-2 with a single circuit board design was released in 2009. The jumper link location is different. See *Setting the Module Jumpers* on pages 5-5 and 5-6. Also, some specifications were changed on page 5-3. Otherwise, the re-designed module functions the same as the prior design.

The F2-08AD-2 Analog Voltage Input module provides several hardware features:

- Analog inputs are optically isolated from the PLC logic.
- The module has a removable terminal block so the module can be easily removed or changed without disconnecting the wiring.
- With a D2-240, D2-250-1, D2-260 or D2-262 CPU, all channels can be updated in one scan.

Firmware Requirements:

To use this module, D2-230 CPUs must have firmware version 1.6 or later. To use the pointer method of writing values, D2-240 CPUs require firmware version 2.2 or later. All versions of the D2-250-1 and D2-260 CPU's firmware support this module and the pointer method.

Analog Input Configuration Requirements

The F2-08AD-2 Analog Input requires 16 discrete input points. The module can be installed in any slot of a DL205 system. The available power budget and discrete I/O points are the limiting factors. Check the user manual for the CPU model and I/O base being used for more information regarding power budget and number of local, local expansion or remote I/O points.

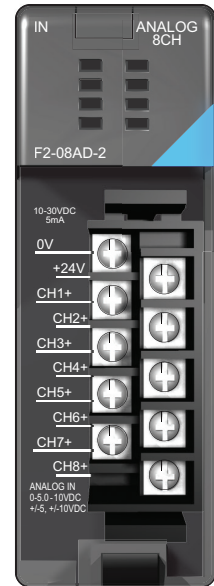

F2-08AD-2

The following tables provide the specifications for the F2-08AD-2 Analog Input Module. Review these specifications to make sure the module meets your application requirements.

Input Specifications	
Number of Channels	8, single ended (one common)
Input Ranges	0–5 V, 0–10 V, $\pm 5V$, $\pm 10V$
Resolution	12 bit (1 in 4096) unipolar (0 – 4095) 13 bit (1 in 8192) bipolar (– 4095 – +4095)
Step Response	1.0 ms (* 4 ms) – 95% of full step change
Crosstalk	–70dB, 1 count maximum
Active Low-pass Filtering	–3 dB @ 200Hz (– 6dB per octave)
Input Impedance	Greater than 20M Ω
Maximum Continuous Overload	$\pm 75VDC$
Linearity Error (End to End)	$\pm 0.025\%$ of span (± 1 count maximum unipolar) (± 2 count maximum bipolar)
Input Stability	± 1 count
Full Scale Calibration Error (Offset error not included)	± 3 counts maximum
Offset Calibration Error	± 1 count maximum, @ 0VDC
Maximum Inaccuracy	$\pm 0.1\%$ @ 25°C $\pm 0.3\%$ 0–60°C (32–140°F)
Accuracy vs. Temperature	$\pm 50ppm/^{\circ}C$ maximum full scale calibration (Including maximum offset change of 2 counts)

General Specifications	
PLC Update Rate	1 channel per scan maximum (D2-230 CPU) 8 channels per scan maximum (D2-240, D2-250 – 1, D2-260 or D2-262 CPU)
Data Acquisition Time	3ms / channel (asynchronous)
Digital Inputs Input points required	12 binary data bits, 1 sign bit 3 channel ID bits, 1 diagnostic bit 16 point (X) input module
Power Budget Requirement	100mA (* 60mA) maximum, 5VDC (supplied by base)
External Power Supply	5mA, 10–30 VDC (*80mA, 18-26.4 VDC)
Operating Temperature	0°C–60°C (32°F to 140°F)
Storage Temperature	–20°C to 70°C (–4°F to 158°F)
Relative Humidity	5–95% (non-condensing)
Environmental air	No corrosive gases permitted
Vibration	MIL STD 810C 514.2
Shock	MIL STD 810C 516.2
Noise Immunity	NEMA ICS3-304



NOTE: Values in parenthesis with an asterisk are for older modules with two circuit board design and date codes 0609D4 and prior. Values not in parenthesis are for single circuit board models with date code 0709E1 and above.

Special Placement Requirements (D2-230 and Remote I/O Bases)

Even though the module can be placed in any slot, it is important to examine the configuration if a D2-230 CPU is used, as can be seen in the section about Writing the Program, located in this chapter. V-memory locations are used to extract the analog data. If the module is placed so the input points do not start on a V-memory boundary, the instructions cannot access the data. This also applies when placing this module in a remote base using a D2-RSSS in the CPU slot.

Correct!

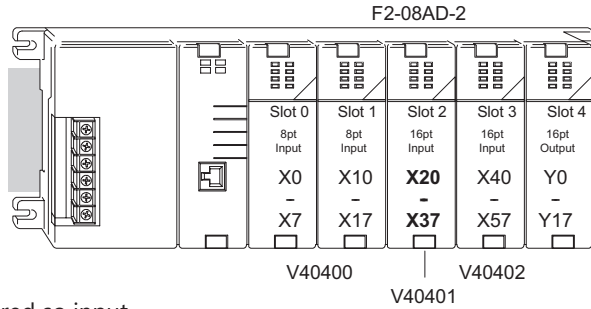

Data is correctly entered so input points start on a V-memory boundary.

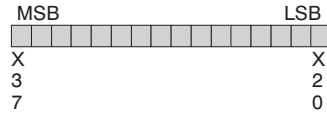

Incorrect

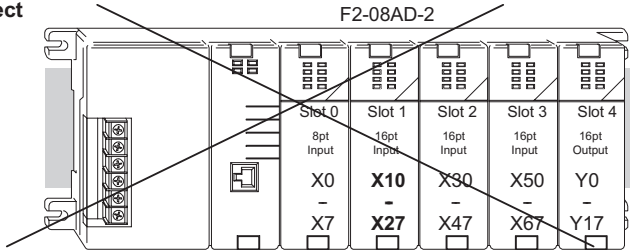

Data is split over two locations, so instructions cannot access data from a D2-230.

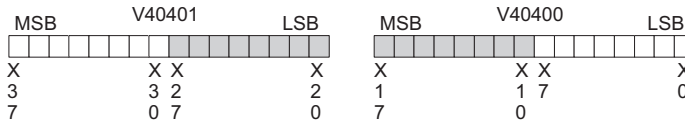

To use the V-memory references required for a D2-230 CPU, the first input address assigned to the module must be one of the following X locations. The table also shows the V-memory addresses that correspond to these X locations.

X	X0	X20	X40	X60	X100	X120	X140	X160
V	V40400	V40401	V40402	V40403	V40404	V40405	V40406	V40407

Setting the Module Jumpers

Selecting the Number of Channels

There are two jumpers, labeled +1, +2, and +4 that are used to select the number of channels that will be used. Use the figures below to locate the jumpers on the module. The module is set from the factory for eight channel operation (all jumpers installed).

Unused channels are not processed. For example, if only channels 1 through 3 are selected, then channels 4 through 8 will not be active. The following table shows how to place the jumpers to select the number of channels.

No. of Channels	+1	+2	+4
1	No	No	No
1, 2	Yes	No	No
1, 2, 3	No	Yes	No
1, 2, 3, 4	Yes	Yes	No
1, 2, 3, 4, 5	No	No	Yes
1, 2, 3, 4, 5, 6	Yes	No	Yes
1, 2, 3, 4, 5, 6, 7	No	Yes	Yes
1, 2, 3, 4, 5, 6, 7, 8	Yes	Yes	Yes

For example, to select all 8 channel operation, leave all jumpers installed. To select 1 channel, remove all three jumpers.

Note that removed jumpers can be stored on a single post to prevent from losing them.

Yes = jumper installed
No = jumper removed

Jumper location on modules having Date Code 0609D4 and previous (two circuit board design)

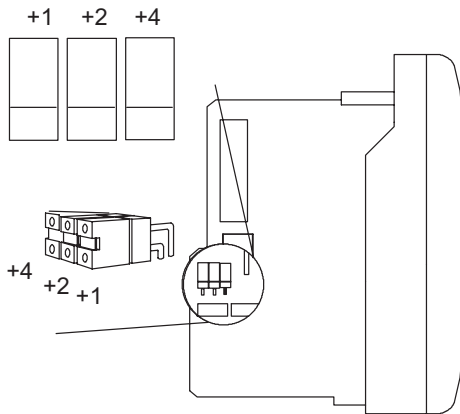

These jumpers are located on the motherboard, the one with the black D-shell style backplane connector.

Jumper location on modules having Date Code 0709E1 and above (single circuit board design)

Use jumpers +1, +2 and +4 to select number of channels.

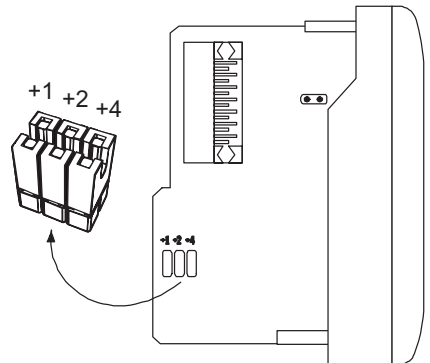

Selecting the Input Voltage

There is another jumper, labeled J3 that is used to select between the 5V ranges and the 10V ranges. See the figures below to locate the jumper on the module being used. The module comes from the factory set for 10V operation (jumper is removed and is stored on one of the pins).



NOTE: Install jumper J3 for 0–5 V or $\pm 5V$ operation.
Remove J3, or store on a single pin, for 0 to 10V or $\pm 10V$ operation.

Jumper J3 location on modules having
Date Code 0609D4 and previous
(two circuit board design)

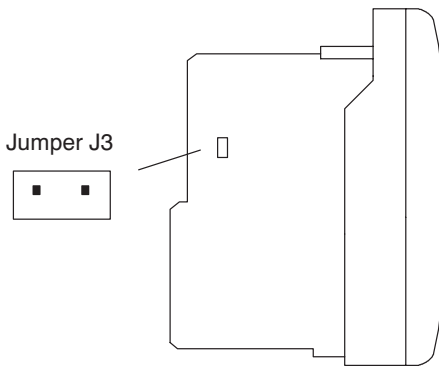

Jumper J3 is located on the smaller circuit board, which is on top of the motherboard.

Install J3 for 0–5 V or $\pm 5V$ operation.
Remove J3, or store on a single pin, for 0–10V or $\pm 10V$ operation.

Jumper J3 location on modules having
Date Code 0709E1 and above
(single circuit board design)

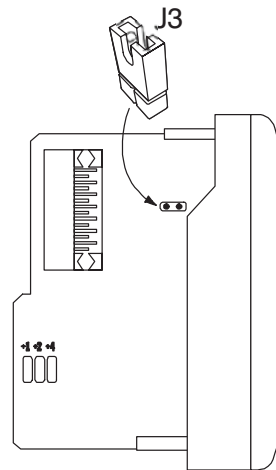

Install J3 for 0–5 V or $\pm 5V$ operation.
Remove J3, or store on a single pin, for 0–10V or $\pm 10V$ operation.

Connecting the Field Wiring

Wiring Guidelines

Your company may have guidelines for wiring and cable installation. If so, check them before starting the installation. Here are some general things to consider:

- Use the shortest wiring route whenever possible.
- Use shielded wiring and ground the shield at the transmitter source. Do not ground the shield at both the module and the source.
- Do not run the signal wiring next to large motors, high current switches, or transformers. This may cause noise problems.
- Route the wiring through an approved cable housing to minimize the risk of accidental damage. Check local and national codes to choose the correct method for your application.

User Power Supply Requirements

The F2-08AD-2 module requires at least one field-side power supply. The same or separate power sources can be used for the module supply and the voltage transmitter supply. The module requires 10–30 VDC, at 5mA, from the external power supply.

The DL205 AC bases have a built-in 24VDC power supply that provide up to 300mA of current. This can be used instead of a separate supply. Check the power budget to be safe.

It is desirable in some situations to power the transmitters separately in a location remote from the PLC. This will work as long as the transmitter supply meets the voltage and current requirements, and that the transmitter and the module supply minus (-) side are connected together.



WARNING: If the 24VDC base power supply is used, Be sure to calculate the power budget. Exceeding the power budget can cause unpredictable system operation that can lead to a risk of personal injury or damage to equipment.

The DL205 base has a switching type power supply. As a result of switching noise, ± 3 –5 counts of instability may be noticed in the analog input data if this power supply is used. If this is unacceptable, try using one of the following.

1. Use a separate linear power supply.
2. Connect the 24VDC common to the frame ground, which is the screw terminal marked on the screw terminal marked "G" on the base.

By using these methods, the input stability is rated at ± 1 count.

Unused inputs should be shorted together and connected to common.

Wiring Diagram

The F2-08AD-2 module has a removable connector to simplify wiring the module. Just squeeze the top and bottom retaining clips and gently pull the connector from the module. Use the following diagram to connect the field wiring

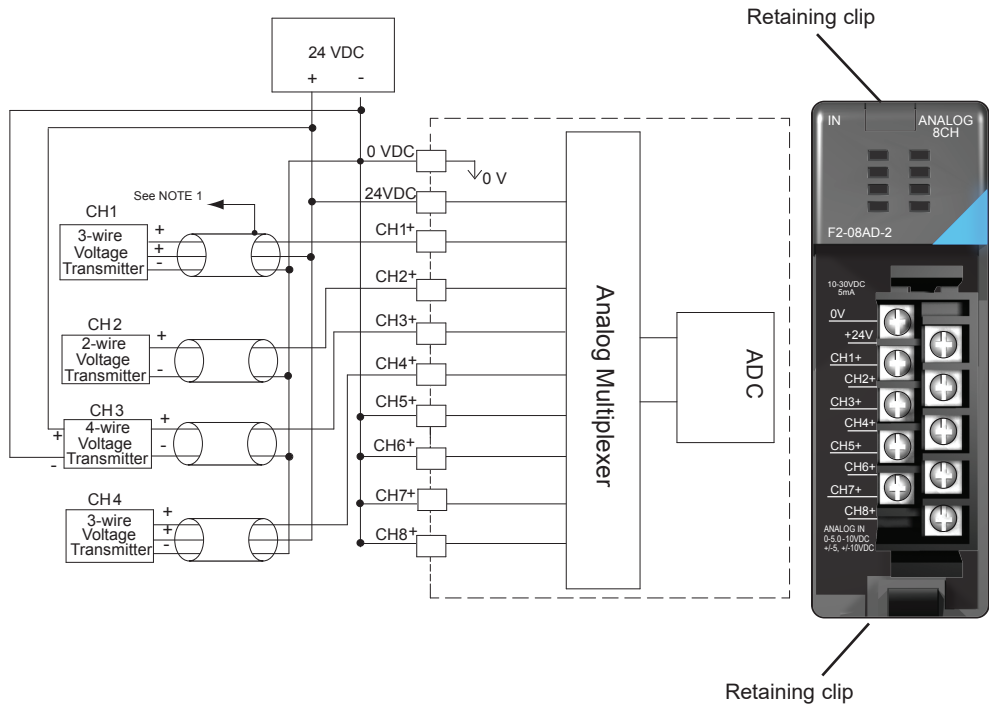

NOTE: Connect unused channels (CH5+, CH6+, CH7+, CH8+ in this diagram) to common (0VDC).

Module Operation

Channel Scanning Sequence (Multiplexing) for a D2-230 CPU

Before beginning to write the control program, it is important to take a few minutes to understand how the module processes and represents the analog signals.

Depending on the type of CPU being used, the F2-08AD-2 module can supply different amounts of data per scan. The D2-230 can obtain one channel of data per CPU scan. Since there are eight channels, it can take up to eight scans to get data for all channels. Once all channels have been scanned the process starts over with channel 1. Unused channels are not processed, so if only two channels are selected, each channel will be updated every other scan. The multiplexing method can also be used for the D2-240, D2-250-1, D2-260 and D2-262 CPUs.

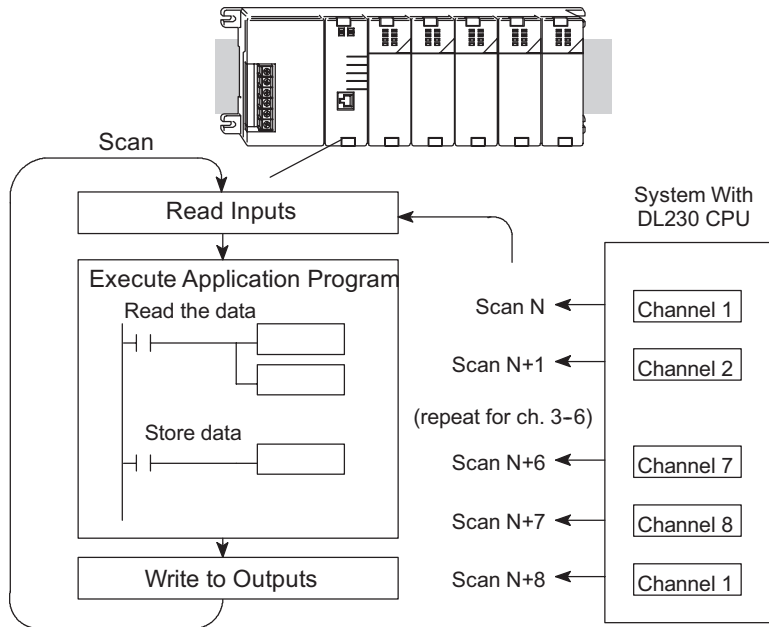

Channel Scanning Sequence (Pointer method) for D2-240, D2-250-1, D2-260 or D2-262 CPUs

If either a D2-240, a D2-250-1, a D2-260 or a D2-262 CPU are used, all eight channels of input data can be collected in one scan. This is because the D2-240, D2-250-, D2-260 and D2-262 CPUs support special V-memory locations that are used to manage the data transfer which is discussed in more detail in the section on Writing the Control Program later in this chapter.

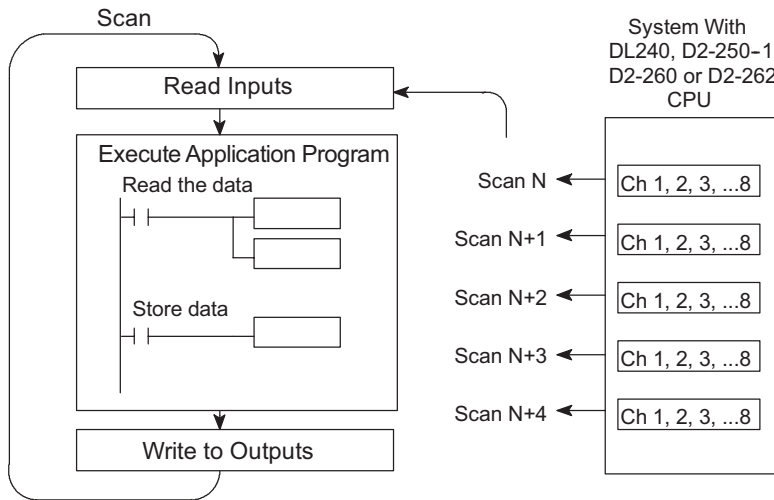

Analog Module Updates

Even though the channel updates to the CPU are synchronous with the CPU scan, the module asynchronously monitors the analog transmitter signal and converts the signal to a 12-bit binary representation. This enables the module to continuously provide accurate measurements without slowing down the discrete control logic in the RLL program.

For the vast majority of applications, the values are updated much faster than the signal changes. However, in some applications, the update time can be important. The module takes approximately one millisecond to sense 95% of the change in the analog signal.



NOTE: This is not the amount of time required to convert the signal to a digital representation. The conversion to the digital representation takes only a few microseconds. Many manufacturers list the conversion time, but it is the settling time of the filter that really determines the update time.

Understanding the Input Assignments

It was mentioned earlier in this chapter that the F2-08AD-2 module appears as a 16-point discrete input module to the CPU. These points can be used to obtain:

- An indication of which channel is active
- The digital representation of the analog signal
- Module diagnostic information

Since all input points are automatically mapped into V-memory, it is very easy to determine the location of the data word that will be assigned to the module.

Within these word locations, the individual bits represent specific information about the

F2-08AD-2

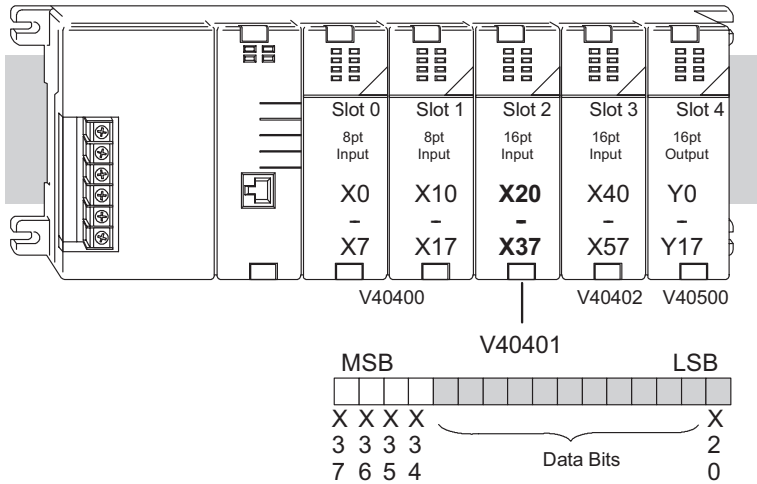

analog signal.

Analog Data Bits

The first twelve bits represent the analog data in binary format.

Bit	Value	Bit	Value
0	1	6	64
1	2	7	128
2	4	8	256
3	8	9	512
4	16	10	1024
5	32	11	2048

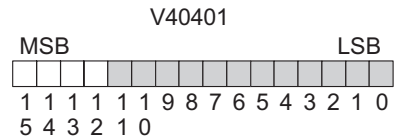

■ = data bits

Active Channel Indicator Inputs

Three of the inputs are binary-encoded to indicate the active channel (remember, the V-memory bits are mapped directly to discrete inputs). The inputs automatically turn on and off to indicate the current channel for each scan.

Scan	X34	X35	X36	Channel
N	Off	Off	Off	1
N+1	On	Off	Off	2
N+2	Off	On	Off	3
N+3	On	On	Off	4
N+4	Off	Off	On	5
N+5	On	Off	On	6
N+6	Off	On	On	7
N+7	On	On	On	8

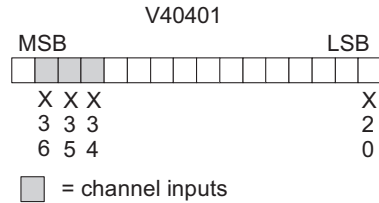

Module Diagnostic and Sign

The MSB input bit is the broken transmitter/ no 24V indicator and the sign indicator.

If the bit is on and the data is zero, there is no 24V input power or the terminal block is loose or missing. If the data is not 0 (zero), the input represents the sign bit.

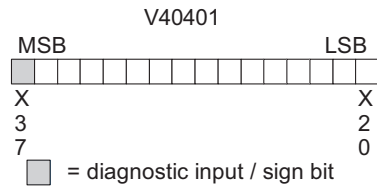

Module Resolution

Since the module has 12-bit unipolar resolution, the analog signal is converted into 4096 counts ranging from 0–4095 (2¹²). For example, with a 0–10V scale, a 0V signal would be 0, and a 10V signal would be 4095. This is equivalent to a binary value of 0000 0000 0000 to 1111 1111 1111, or 000 to FFF hexadecimal. The diagram shows how this relates to each signal range. The bipolar ranges utilize a sign bit to provide 13-bit resolution. A value of 4095 can represent the upper limit of either side of the range. Use the sign bit to determine negative values.

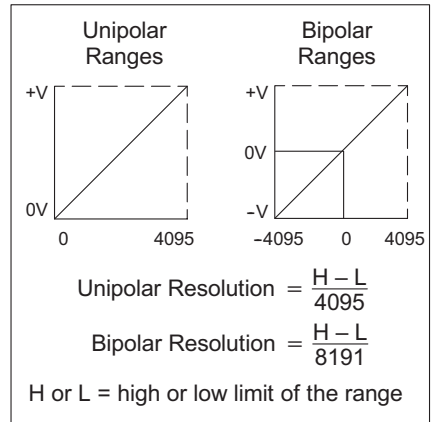

Each count can also be expressed in terms of the signal level by using the equation shown on the facing page. The following table shows the smallest detectable signal change that will result in one LSB change in the data value for each input signal range.

Voltage Range	Signal Span (H – L)	Divide By	Smallest Detectable Change
0V to +10V	10V	4095	2.44 mV
-10V to +10V	20V	8191	2.44 mV
0V to +5V	5V	4095	1.22 mV
-5V to +5V	10V	8191	1.22 mV

Writing the Control Program

Reading Values: Pointer Method and Multiplexing

There are two methods of reading values:

1. The pointer method
2. Multiplexing

The multiplexing method must be used when using a D2-230 CPU. The multiplexing method must also be used with remote I/O modules (the pointer method will not work). Either method can be used with the D2-240, D2-250-1, D2-260 and D2-262 CPUs, but for ease of programming it is strongly recommended to use the pointer method.

Pointer Method for D2-240, D2-250-1, D2-260 and D2-262 CPUs

The DL205 series has special V-memory locations assigned to each base slot that will greatly simplify the programming requirements. These V-memory locations allow you to:

- Specify the data format
- Specify the number of channels to scan
- Specify the storage locations



NOTE: D2-240 CPUs with firmware release version 2.2 or later support this method. D2-250 CPUs with firmware release version 1.06 or later support this method. If the D2-230 example needs to be used, module placement in the base is very important. Review the section earlier in this chapter for guidelines.

The example program shows how to setup these locations. Place this rung anywhere in the ladder program, or in the initial stage if stage programming instructions are being used. This is all that is required to read the data into V-memory locations. Once the data is in V-memory, math can be used on the data, compare the data against preset values, and so forth. V2000 is used in the example but any user V-memory location can be used. In this example the module is installed in slot 2. Be sure to use the V-memory locations for the module placement. The pointer method automatically converts values to BCD (depending on the LD statement in the ladder logic).

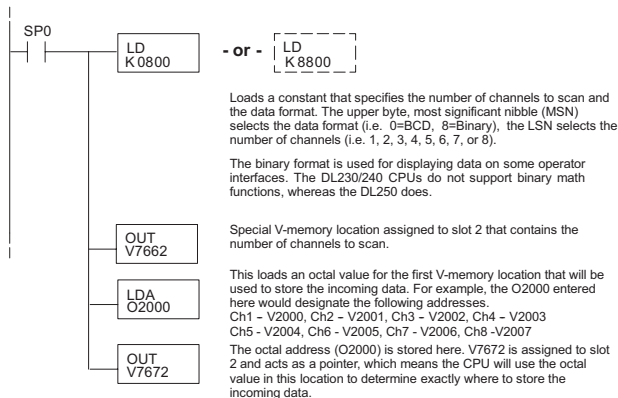

The tables below show the special V-memory locations used by the D2-240, D2-250-1, D2-260 and D2-262 CPUs for the base and local expansion base I/O slots. Slot 0 (zero) is the module next to the CPU or D2-CM module. Slot 1 is the module two places from the CPU or D2-CM, and so on. Remember, the CPU only examines the pointer values at these locations after a mode transition. Also, if you use the D2-230 (multiplexing) method, verify that these addresses in the CPU are 0 (zero).

The Table below applies to the D2-240, D2-250-1, D2-260 and D2-262 CPU base.

CPU Base: Analog Input Module Slot-Dependent V-memory Locations								
Slot	0	1	2	3	4	5	6	7
No. of Channels	V7660	V7661	V7662	V7663	V7664	V7665	V7666	V7667
Storage Pointer	V7670	V7671	V7672	V7673	V7674	V7675	V7676	V7677

The Table below applies to the D2-250-1, D2-260 or the D2-262 CPU base 1.

Expansion Base D2-CM #1: Analog Input Module Slot-Dependent V-memory Locations								
Slot	0	1	2	3	4	5	6	7
No. of Channels	V36000	V36001	V36002	V36003	V36004	V36005	V36006	V36007
Storage Pointer	V36010	V36011	V36012	V36013	V36014	V36015	V36016	V36017

The Table below applies to the D2-250-1, D2-260 or the D2-262 CPU base 2.

Expansion Base D2-CM #2: Analog Input Module Slot-Dependent V-memory Locations								
Slot	0	1	2	3	4	5	6	7
No. of Channels	V36100	V36101	V36102	V36103		V36105	V36106	V36107
Storage Pointer	V36110	V36111	V36112	V36113	V36114	V36115	V36116	V36117

The Table below applies to the D2-260 and D2-262 CPU base 3.

Expansion Base D2-CM #3: Analog Input Module Slot-Dependent V-memory Locations								
Slot	0	1	2	3	4	5	6	7
No. of Channels	V36200	V36201	V36202	V36203	V36204	V36205	V36206	V36207
Storage Pointer	V36210	V36211	V36212	V36213	V36214	V36215	V36216	V36217

The Table below applies to the D2-260 and D2-262 CPU base 4.

Expansion Base D2-CM #4: Analog Input Module Slot-Dependent V-memory Locations								
Slot	0	1	2	3	4	5	6	7
No. of Channels	V36300	V36301	V36302	V36303	V36304	V36305	V36306	V36307
Storage Pointer	V36310	V36311	V36312	V36313	V36314	V36315	V36316	V36317

Using Bipolar Ranges (Pointer Method) for D2-240, D2-250-1, D2-260 and D2-262 CPUs

Some additional logic is needed with bipolar ranges to determine whether the value being returned represents a positive voltage or a negative voltage. For example, the direction of a motor may be needed to be known. With the D2-240 or D2-250 CPU, the last input cannot be used to show the sign for each channel (X37 in the previous examples). This is because the D2-240, D2-250-1, D2-260 and D2-262 reads all eight channels in one scan. Therefore, if X37 were used, the last channel read would just be monitored and the sign would not be able to be determined for the previous channels. A simple solution is if the value read is greater than or equal to 8001, the value is negative.

The sign bit is the most significant bit, which combines 8000 with the data value. If the value is greater than or equal to 8001, only the most significant bit and the active channel bits will need to be masked to determine the actual data value.

The following program shows how to accomplish this. Since a negative value is always meant to be known, these rungs should be placed before any other operations that use the data, such as math instructions, scaling operations, and so forth. Also, if stage programming instructions are being used, place these rungs in a stage that is always active. Please note, this logic is only needed for each channel that is using bipolar input signals. The following example only shows two channels.

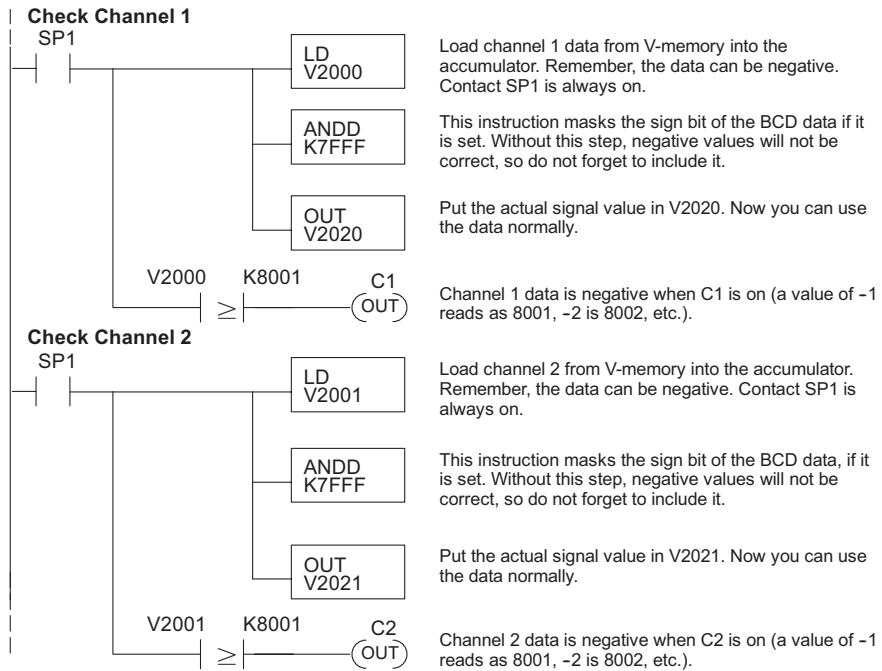

Reading Values (Multiplexing) for D2-230, D2-240, D2-250-1, D2-260 and D2-262 CPUs

The D2-230 CPU does not have the special V-memory locations which will allow data transfer to be automatically enabled. Since all channels are multiplexed into a single data word, the control program must be setup to determine which channel is being read. Since the module appears as X input points to the CPU, it is very easy to use the active channel status bits to determine which channel is being monitored.



NOTE: This example is for a module installed as shown in the previous examples. The addresses used would be different if the module is installed in a different I/O arrangement. The rungs can be placed anywhere in the program, or if stage programming is being used, place them in a stage that is always active.

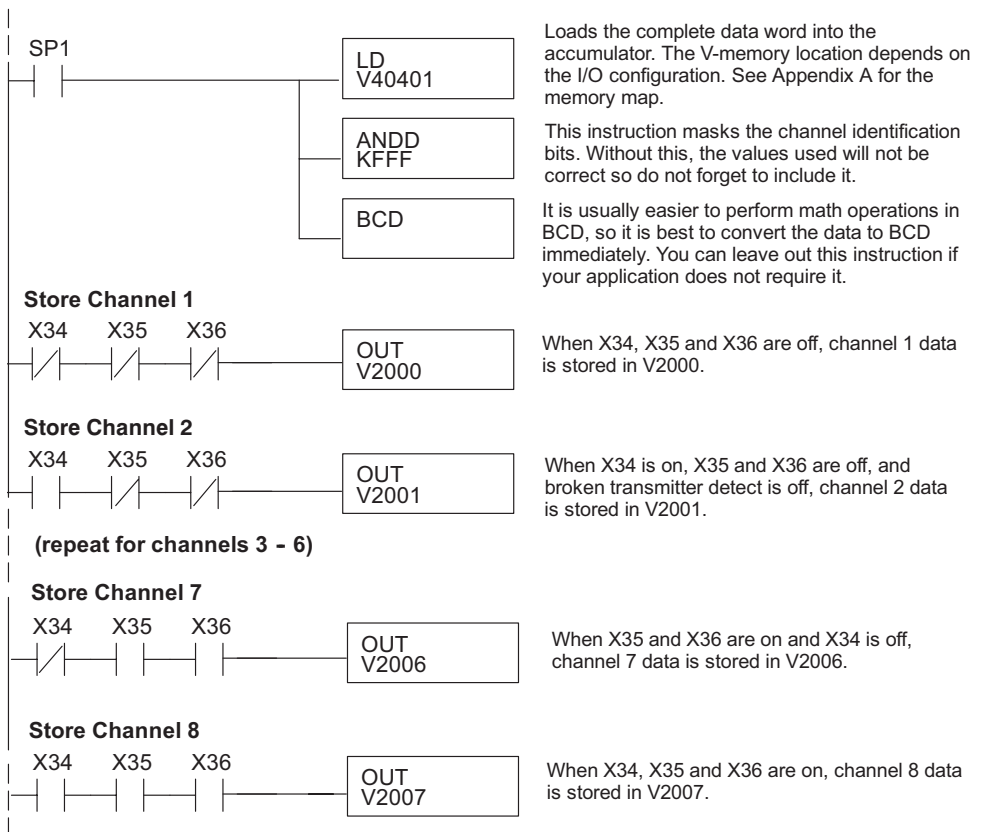

Single Channel Selected

The single channel program makes it easy to determine which channel has been selected.

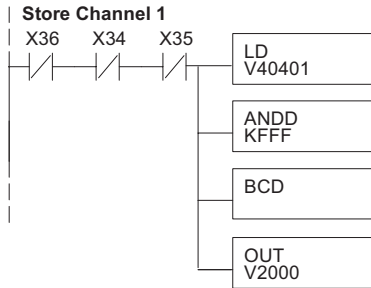

Loads the complete data word into the accumulator. The V-memory location depends on the I/O configuration. See Appendix A for the memory map.

This instruction masks the channel identification bits. Without this, the values used will not be correct, so do not forget to include it.

It is usually easier to perform math operations in BCD. So it is best to convert the data to BCD immediately. You can leave out this instruction if your application does not require it.

When the module is not busy, and X34 and X35 are off, channel 1 data is stored in V2000.

Using Bipolar Ranges (Multiplexing)

Some additional logic is needed with bipolar ranges to determine whether the value being returned represents a positive voltage or a negative voltage. For example, the direction of a motor may be needed to be known. Since the D2-230 only reads one channel per scan, the last input can be used to show the sign (X37 in the examples).

The following program shows how to accomplish this. Since a negative value is always needed to be known, these rungs should be placed before any other operations that use the data, such as math instructions, scaling operations, and so forth. Also, if stage programming instructions are being used, place these rungs in a stage that is always active. Please note, this logic is only needed for each channel that is using bipolar input signals. The following example only shows two channels but the rungs can be repeated for all eight channels if needed.

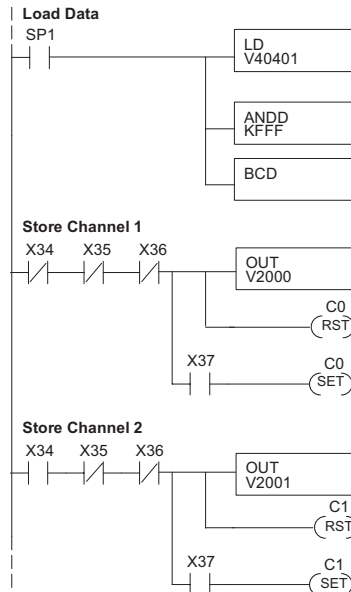

Loads the complete data word into the accumulator. The V-memory location depends on the I/O configuration. See Appendix A for the memory map.

This instruction masks the channel identification bits. Without this, the values used will not be correct, so do not forget to include it.

It is usually easier to perform math operations in BCD, so it is best to convert the data to BCD immediately. You can leave out this instruction if your application does not require it.

When the module is not busy, and X34, X35 and X36 are off, channel 1 data is stored in V2000. C0 is reset to indicate channel 1's value is positive.

If X37 is on, then the data value represents a negative voltage. C0 is set to indicate channel 1's value is negative.

When the module is not busy, and X34 is on and X35 and X36 are off, channel 2 data is stored in V2001. C1 is reset to indicate channel 2's value is positive.

If X37 is on, then the data value represents a negative voltage. C1 is set to indicate channel 2's value is negative.

Using 2's Complement (Multiplexing) for D2-230, D2-240, D2-250-1, D2-260 and D2-262 CPUs

The 2's complement data format may be required to display negative values on some operator interface devices. It could also be used to simplify data averaging on bipolar signals.

The example shows two channels, but these steps can be repeated for all eight channels if necessary.

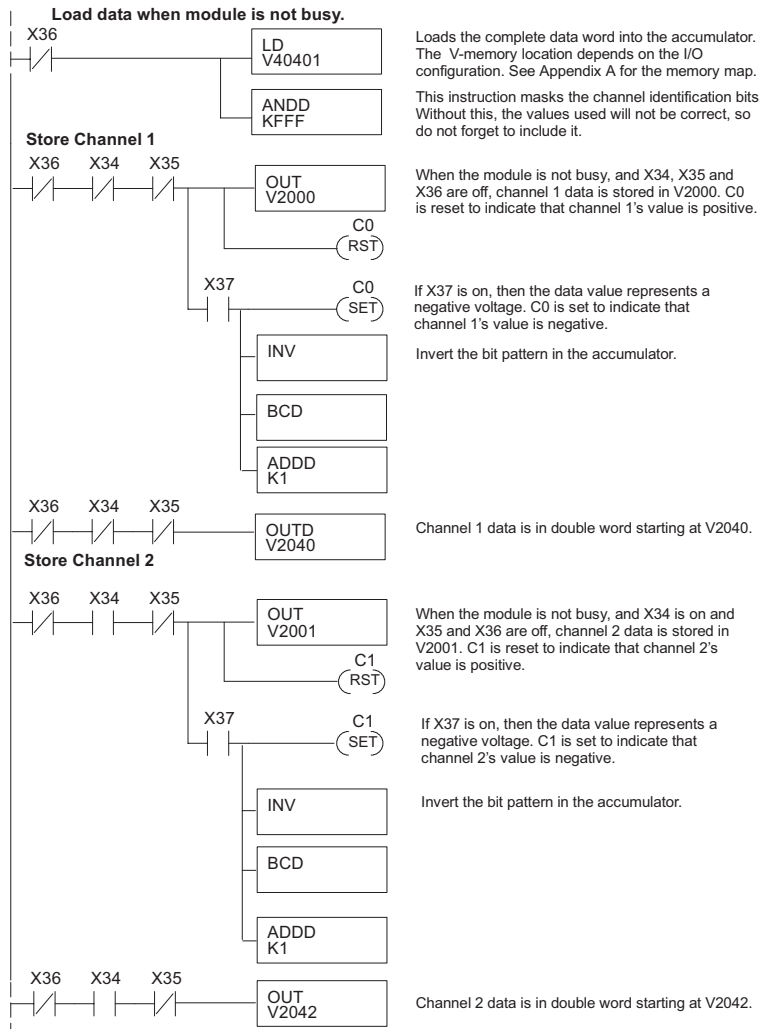

Analog Power Failure Detection

The analog module has a microcontroller which can diagnose analog input circuit problems. A ladder rung can be added to program to detect these problems. This rung shows an input point that would be assigned if the module was used as shown in the previous examples. A different point would be used if the module was installed in a different I/O configuration.

Multiplexing method

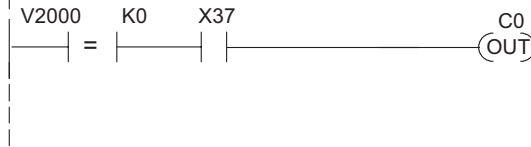

V-memory location V2000 holds channel 1 data. When a data value of zero is returned and input X37 is on, then the analog circuitry is not operating properly.

Pointers method

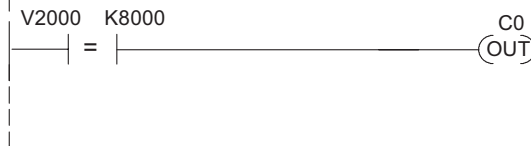

V-memory location V2000 holds channel 1 data. When a data value of 8000 is returned, then the analog circuitry is not operating properly.

Scaling the Input Data

Most applications usually require measurements in engineering units which provides more meaningful data. This is accomplished by using the conversion formula shown.

Adjustments may be needed to the formula depending on the scale being used for the engineering units.

For example, if pressure (psi) is to be measured from 0.0–99.9 then multiply the value by 10 in order to imply a decimal place when viewing the value with the programming software or with a handheld programmer. Notice how the calculations differ when the multiplier is used.

Analog Value of 2024, slightly less than half scale, should yield 49.4 psi.

$$\text{Units} = A \frac{H-L}{4095}$$

U = Engineering Units

A = Analog Value (0 – 4095)

H = High limit of the engineering unit range

L = Low limit of the engineering unit range

Example without multiplier

$$\text{Units} = A \frac{H-L}{4095}$$

$$\text{Units} = 2024 \frac{100-0}{4095}$$

$$\text{Units} = 49$$

Example with multiplier

$$\text{Units} = 10A \frac{H-L}{4095}$$

$$\text{Units} = 20240 \frac{100-0}{4095}$$

$$\text{Units} = 494$$

The Conversion Program

The following example shows how to write the program to perform the engineering unit conversion. This example assumes the raw input data read at V2000 is in BCD format.



NOTE: This example uses SP1, which is always on, but any permissive contact such as, X, C, etc., can be used.

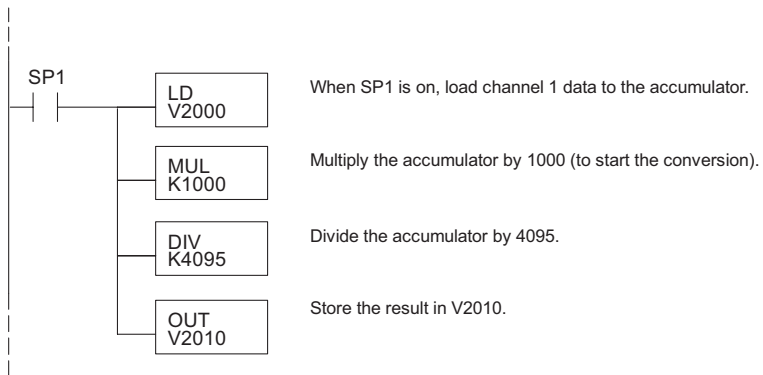

Analog and Digital Value Conversions

Sometimes it is useful to be able to quickly convert between the signal levels and the digital values. This is especially helpful during machine startup or troubleshooting. Remember, that this module does not operate like other versions of analog input modules. The bipolar ranges use 0-4095 for both positive and negative voltages. The sign bit allows this, which actually provides better resolution than those modules that do not offer a sign bit. The following table provides formulas to make this conversion easier.

Range	If the digital value is known	If the analog signal level is known.
0-5 V ±5V	$A = 5D$ 4095	$D = \frac{4095(A)}{5}$
0-10 V ±10V	$A = 5D$ 4095	$D = \frac{4095 \text{ ABS}(A)}{10}$

As an example, if the range being used is ±10V and the measured signal is 6V, use the formula to the right to determine the digital value that is stored in the V-memory location that contains the data.

$$D = \frac{4095(A)}{10}$$

$$D = \frac{4095(6V)}{10}$$

$$D = (409.5)(6)$$

$$D = 2457$$

Filtering Input Noise for D2-250-1, D2-260 and D2-262 CPUs

Add the following logic to filter and smooth analog input noise in D2-250-1, D2-260 and D2-262 CPUs. This is especially useful when using PID loops. Noise can be generated by the field device and or induced by field wiring.

In the following example, the analog value in BCD is first converted to a binary number. Memory location V1400 is the designated work space in this example. The MULR instruction is the filter factor, which can be from 0.1–0.9. The example uses 0.2. A smaller filter factor increases filtering. A higher precision value can be used, but it is not generally needed. The filtered value is then converted back to binary and then to BCD. The filtered value is stored in location V1402 for use in your application or PID loop.

NOTE: Please review intelligent instructions (IBox) in Chapter 5 of D2-USER-M, which simplify this and other functions. The IBox instructions are supported by the D2-250-1, D2-260 and D2-262.



NOTE: Be careful not to do a multiple number conversion on a value. For example, if you are using the pointer method to get the analog value, it is in BCD and must be converted to binary. However, if you are using the conventional method of reading analog and are masking the first twelve bits, then it is already in binary and no conversion using the BIN instruction is needed.

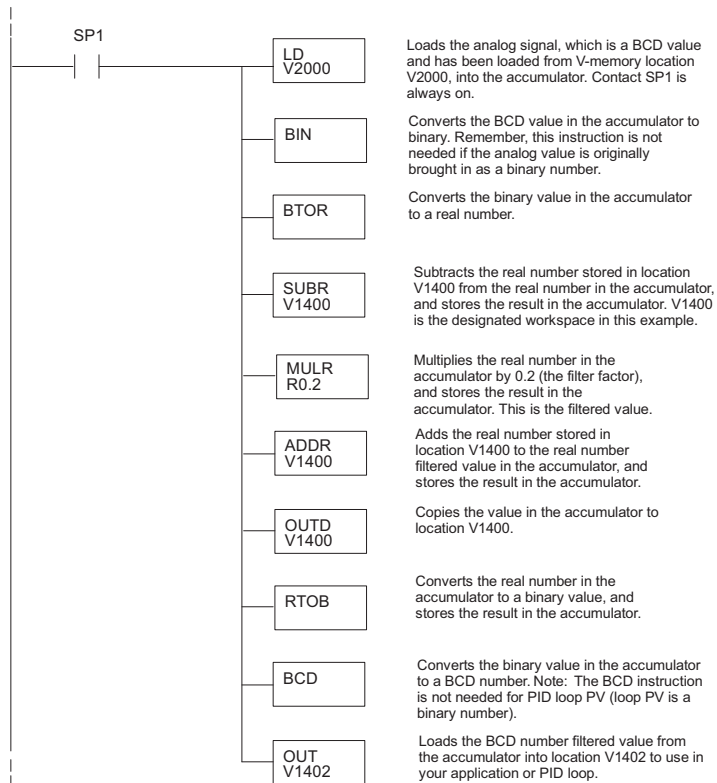

F2-04RTD 4-CHANNEL RTD INPUT



In This Chapter...

Module Specifications	6-2
Setting the Module Jumpers	6-5
Connecting the Field Wiring.....	6-7
Module Operation	6-9
Writing the Control Program.....	6-11

Module Specifications

The F2-04RTD 4-Channel Resistive Temperature Detector Input Module provides the following features and benefits:

- Provides four RTD input channels with 0.1 °F temperature resolution.
- Automatically converts type Pt100Ω, jPt100Ω, Pt1000Ω, Cu25Ω, Cu10Ω signals into direct temperature readings. No extra scaling or complex conversion is required.
- Temperature data can be expressed in °F or °C, and as magnitude plus sign or 2's complement.
- Precision lead wire resistance compensation by dual matched current sources and ratiometric measurements.
- The temperature calculation and linearization are based on data provided by the National Institute of Standards and Technology (NIST).
- Diagnostic features include detection of short circuits and input power disconnection.

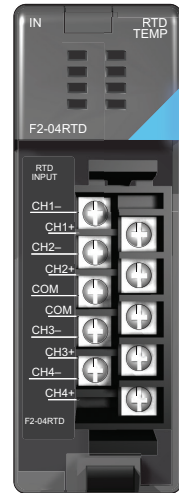

Module Calibration

The module automatically re-calibrates every five seconds to remove any offset and gain errors. The F2-04RTD module requires no user calibration. However, if your process requires calibration, it is possible to correct the RTD tolerance using ladder logic. A constant can be added or subtracted to the actual reading for that particular RTD.

RTD Input Configuration Requirements

The F2-04RTD temperature input module requires 32 discrete input points. The module can be installed in any slot of a DL205 system, including remote bases. The limiting factors on the number of analog modules used are:

- For local and local expansion systems, the available power budget and number of discrete I/O points.
- For remote I/O systems, the available power budget and number of remote I/O points.

Check the user manual for the particular CPU model being used for more information regarding the available power budget and number of local, local expansion or remote I/O points.



NOTE: D2-230 CPUs with firmware release version 1.6 or later, D2-240 CPUs with firmware release 2.5 or later, D2-250 CPUs with firmware release version 1.06 or later are required for proper operation.

Input Specifications

The following table provides the specifications for the F2-04RTD Input Module. Review these specifications to make sure the module meets your application requirements.

Input Specifications	
Number of Channels	4, differential inputs
Input Ranges	Pt100 -200.0°C – 850.0°C (-328°F – 1562°F) PT1000 -200.0°C – 595.0°C (-328°F – 1103°F) jPt100 -38.0°C – 450.0°C (-36°F – 842°F) Cu10Ω -200.0°C – 260.0°C (-328°F – 500°F) Cu25Ω -200.0°C – 260.0°C (-328°F – 500°F)
Resolution	±0.1°C, ±0.1°F (±3276.7)
Absolute Maximum Ratings	Fault Protected Inputs to ±50VDC
Converter Type	Charge Balancing, 24 bit
Sampling Rate	160ms per channel
Linearity Error (End to End)	±0.05°C maximum, ±0.01°C typical
PLC Update Rate	4 channels per scan max. (D2-240, D2-250–1, D2-260 or D2-262 CPU) 1 channel per scan max. (230 CPU)
Temperature Drift	5ppm per °C (maximum)
Maximum Inaccuracy	maximum inaccuracy = ±1°C
RTD Excitation Current	200μA
Common Mode Range	0–5 VDC
Notch Filter	>100dB notches @ 50/60Hz f-3dB = 13.1 Hz
Digital Input Points Required	32 (X) input points 15 binary data bits, 1 sign bit, 2 channel ID bits 4 fault bits
Power Budget Requirements	90mA @ 5VDC (supplied by base)
Operating Temperature	0–60°C (32–140°F)
Storage Temperature	-20 to 70°C (-4 to 158°F)
Relative Humidity	5–95% (non-condensing)
Environmental Air	No corrosive gases permitted
Vibration	MIL STD 810C 514.2
Shock	MIL STD 810C 516.2
Noise Immunity	NEMA ICS3-304

Special Placement Requirements (D2-230 and Remote I/O Bases)

It is important to examine the configuration if a D2-230 CPU is being used. As can be seen in the section on Writing the Control Program, V-memory locations are used to manage the analog data. If the module is placed so that the input points do not start on a V-memory boundary, the instructions will not be able to access the data. This also applies when placing this module in a remote base using a D2-RSSS in the CPU slot. Refer to the diagrams below.

Correct!

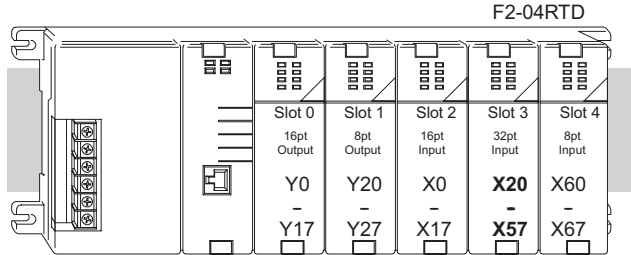

Data is correctly entered so input points start on a V-memory boundary address from the table below.

V40402			V40401		
MSB		LSB	MSB		LSB
X	X X	X	X X	X X	X
7	5 4	4	3	3 2	2
7	0 7	0	7	0 7	0

Incorrect

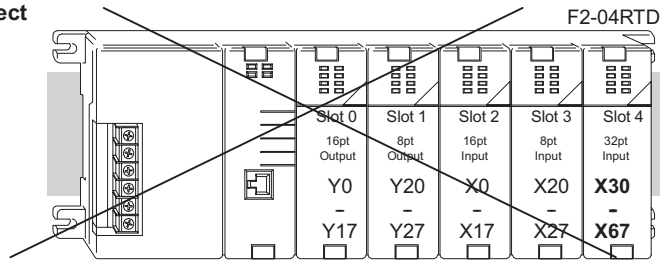

Data is split over three locations, so instructions cannot access data from a D2-230.

V40403			V40402			V40401		
MSB		LSB	MSB		LSB	MSB		LSB
X	X X	X	X	X X	X	X	X X	X
7	7 6	6	5	5 4	4	3	3 2	2
7	0 7	0	7	0 7	0	7	0 7	0

To use the V-memory references required for a D2-230 CPU, the first input address assigned to the module must be one of the following X locations. The table also shows the V-memory addresses that correspond to these X locations.

X	X0	X20	X40	X60	X100	X120	X140	X160
V	V40400	V40401	V40402	V40403	V40404	V40405	V40406	V40407

Setting the Module Jumpers

Jumper Locations

Locate the bank of seven jumpers (J8) on the PC board. Notice that the description of each jumper is on the PC board. The following options can be selected by installing or removing the jumpers:

- Number of channels: 1–4.
- The input type: 10Ω or 25Ω copper, jPt100Ω, Pt100Ω or Pt1000Ω RTDs
- Temperature conversion: 2’s complement or magnitude plus sign format in Fahrenheit or Celsius.

To prevent losing a jumper when it is removed, store it near its original location by sliding one of its sockets over a single pin.

Selecting the Number of Channels

The two jumpers labeled CH+1 and CH+2 are used to select the number of channels that will be used. The factory default setting is four-channel operation (both jumpers installed). Any unused channels are not processed. For example, if you select channels 1 – 3, channel 4 will be inactive. The table shows how to arrange the jumpers to select the number of channels.

X = jumper installed, empty space = jumper removed

Number of Channels	Jumper	
	CH+1	CH+2
1		
2	X	
3		X
4	X	X

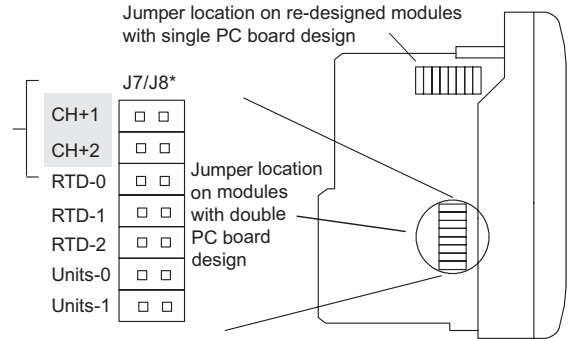

* Jumper is designated J8 on double PC board models and J7 on single PC board models.

Setting Input Type

The jumpers labeled RTD-0, RTD-1, and RTD-2 are used to select the type of RTD. The module can be used with many types of RTDs however, all channels of the module must be the same RTD type.

The default setting from the factory is Pt100Ω (RTD-2 comes with the jumper removed). This selects the DIN 43760 European type RTD. European curve type RTDs are calibrated to DIN 43760, BS1905, or IEC751 specification which is 0.00385 Ω/Ω/°C (100°C = 138.5Ω).

The jPt100Ω type is used for the American curve (0.00392 Ω/Ω/°C), platinum 100Ω RTDs. The 10Ω and 25Ω RTD settings are used with copper RTDs.

The table shows how to arrange the jumpers to set the input type.

X = jumper installed, empty space = jumper removed.

RTD Inputs	Jumper Pins		
	RTD-0	RTD-1	RTD-2
<i>Cu 10Ω</i>			
<i>Cu 25Ω</i>	X		
<i>jPt100Ω</i>		X	
<i>Pt100Ω</i>	X	X	
<i>Pt1000Ω</i>			X

Selecting the Conversion Units

Use the last two jumpers, Units-0 and Unit-1, to set the conversion unit. The options are magnitude + sign or 2's complement in Fahrenheit or Celsius. The module comes from the factory with both jumpers installed for magnitude + sign conversion in Fahrenheit.

All RTD types are converted into a direct temperature reading in either Fahrenheit or Celsius. The data contains one implied decimal place. For example, a value in V-memory of 1002 would be 100.2°C or °F.

Negative temperatures can be represented in either 2's complement or magnitude plus sign form. If the temperature is negative, the most significant bit in the V-memory location is set (X17, if the starting address for the module is X0).

The 2's complement data format may be required to correctly display bipolar data on some operator interfaces. This data format could also be used to simplify averaging a bipolar signal. To view this data format in DirectSoft, select Signed Decimal.

The table shows how to arrange the jumpers.

X = jumper installed, empty space = jumper removed.

Number of Channels	Temperature Conversion Units			
	Magnitude + Sign		2's Compliment	
	°F	°C	°F	°C
<i>Units-0</i>	X		X	
<i>Units-1</i>	X	X		

Connecting the Field Wiring

Wiring Guidelines

Your company may have guidelines for wiring and cable installation. If so, check the guidelines before beginning the installation. Here are some general things to consider:

- Use the shortest wiring route whenever possible.
- Use shielded wiring and ground the shield at the transmitter source. Do not ground the shield at both the module and the source.
- Do not run the signal wiring next to large motors, high current switches, or transformers. This may cause noise problems.
- Route the wiring through an approved cable housing to minimize the risk of accidental damage. Check local and national codes to choose the correct method for your application.

RTD - Resistance Temperature Detector

Use shielded RTDs whenever possible to minimize noise on the input signal. Ground the shield wire at one end only, preferably at the RTD source.

Lead Configuration for RTD Sensors

The suggested three-lead configuration shown below provides one lead to the CH+ terminal, one lead to the CH- terminal, and one lead to the common terminal. Compensation circuitry nulls out the lead length for accurate temperature measurements.

Some sensors have four leads. When making connections, do not connect the second lead to the CH+ input; leave that lead unconnected.

Do not use configurations that lack the use of the same color lead to both the CH- and COM terminals. There is no compensation so temperature readings will be inaccurate.

This module has low RTD excitation current, the worst case dissipation with 100Ω RTDs connected is only 0.016 mW.

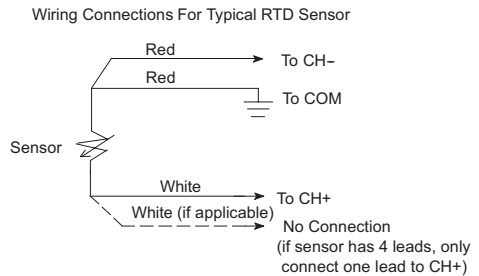

Ambient Variations in Temperature

The F2-04RTD module has been designed to operate within the ambient temperature range of 0 to 60°C.

Precision analog measurement with no long term temperature drift is assured by a chopper stabilized programmable gain amplifier, ratiometric referencing, and automatic offset and gain calibration.

Wiring Diagram

The F2-04RTD module has a removable connector to make wiring easier. Simply squeeze the top and bottom retaining clips and gently pull the connector from the module.

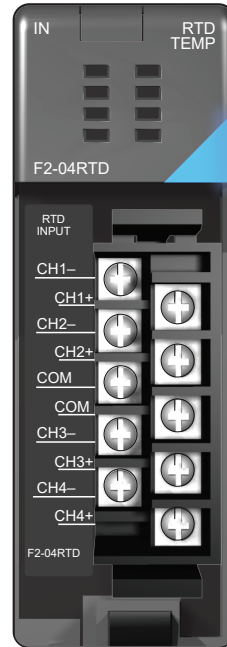
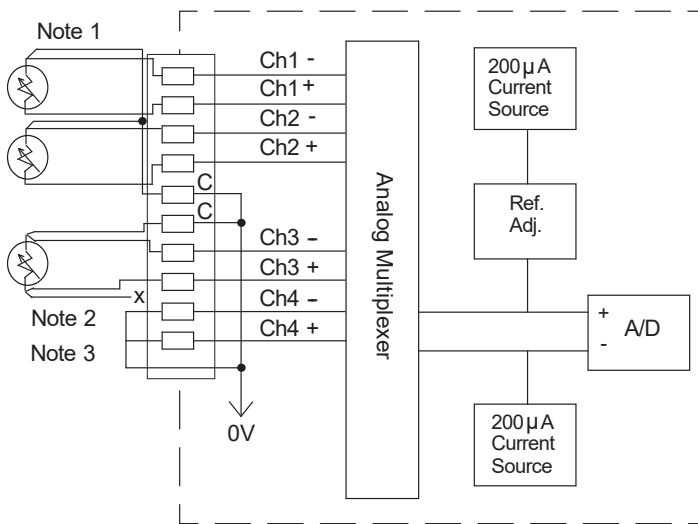

NOTE 1: The three wires connecting an RTD to the module must be the same type and length. Do not use the shield or drain wire for the third connection.

NOTE 2: If an RTD sensor has four wires, the plus (+) sense wire should be left unconnected as shown.

NOTE 3: Short unused channels to COM terminal (C)

Module Operation

Before beginning to write the control program, it is important to take a few minutes to understand how the module processes the analog signals.

Channel Scanning Sequence (Multiplexing) for a D2-230 CPU

The F2-04RTD module can supply different amounts of data per scan, depending on the type of CPU being used. The D2-230 can obtain one channel of data per CPU scan. Since there are four channels, it can take up to four scans to get data for all channels. Once all channels have been scanned the process starts over with channel 1. Unused channels are not processed, so if only two channels are selected, each channel will be updated every other scan. The multiplexing method can also be used for the D2-240, D2-250-1, D2-260 or D2-262 CPUs.

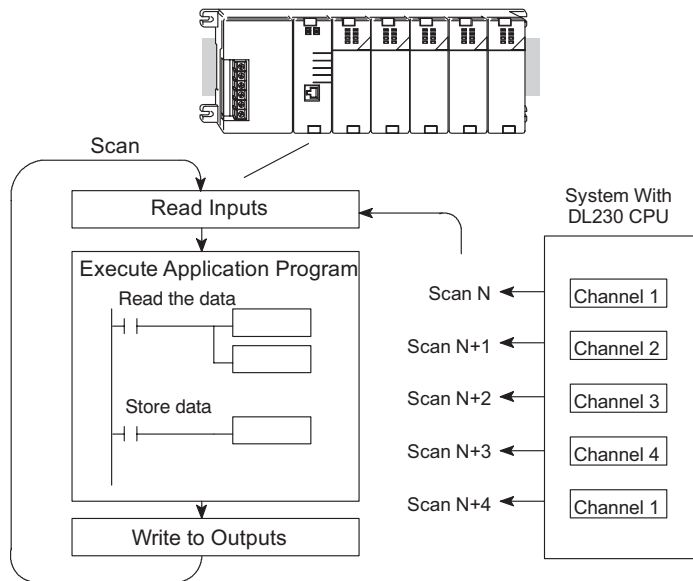

Channel Scanning Sequence (Pointer Method) for D2-240, D2-250-1, D2-260 or D2-262 CPUs

If a D2-240, a D2-250-1, a D2-260 or a D2-262 CPU is being used, all four channels of input data can be captured in one scan. This is because the D2-240, D2-250-1, D2-260 and D2-262 CPUs support special V-memory locations that are used to manage the data transfer. This is discussed in more detail in the next section on Writing the Control Program.

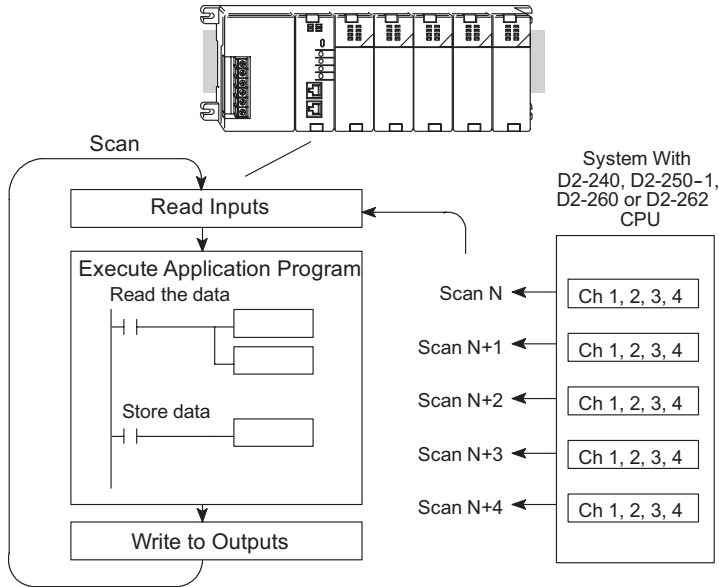

Analog Module Updates

Even though the channel updates to the CPU are synchronous with the CPU scan, the module asynchronously monitors the analog transmitter signal and converts the signal to a 16-bit binary representation. This enables the module to continuously provide accurate measurements without slowing down the discrete control logic in the RLL program.

The time required to sense the temperature and copy the value to V-memory is 160ms minimum to 640ms plus 1 scan time maximum (number of channels x 160ms + 1 scan time).

Writing the Control Program

Reading Values: Pointer Method and Multiplexing

There are two methods of reading values:

- Pointer method
- Multiplexing

The multiplexing method must be used with a D2-230 CPU. The multiplexing method must also be used with remote I/O modules (the pointer method will not work). Either method can be used with the D2-240, D2-250-1, D2-260 or D2-262 CPUs, but for ease of programming it is highly recommended to use the pointer method.

Pointer Method for the D2-240, D2-250-1, D2-260 or D2-262 CPUs

The CPU has special V-memory locations (shown in tables on the following page) assigned to each base slot that greatly simplifies the programming requirements. These V-memory locations allow you to:

- Specify the data format
- Specify the number of channels to scan.
- Specify the storage locations.

The example program shows how to setup these locations. Place this rung anywhere in the ladder program, or in the initial stage if stage programming instructions are used. This is all that is required to read the data into V-memory locations. Once the data is in V-memory, math instructions can be used on the data, compare the data against preset values, etc. V2000 is used in the example, but any user V-memory location can be used. The module is installed in slot 2 for the examples. Use the V-memory locations shown in the application. The pointer method automatically converts values to BCD.



NOTE: D2-240 CPUs with firmware release version 2.5 or later and D2-250 CPUs with firmware release version 1.06 or later support this method. Use the D2-230 multiplexing example if the firmware revision is earlier.

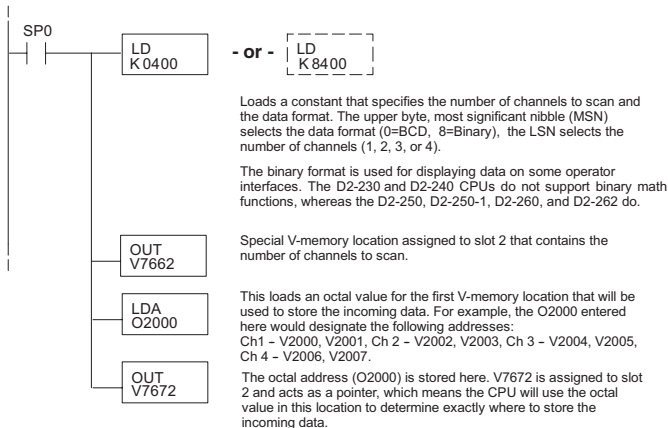

The following tables show the special V-memory locations used by the D2-240, D2-250-1, D2-260 or D2-262 for the CPU base and local expansion base I/O slots. Slot 0 (zero) is the module next to the CPU or D2-CM module. Slot 1 is the module two places from the CPU or D2-CM, and so on. Remember, the CPU only examines the pointer values at these locations after a mode transition. Also, if the D2-230 (multiplexing) method is used, verify that these addresses in the CPU are 0 (zero).

The Table below applies to the D2-240, D2-250-1, D2-260 or D2-262 CPU base.

CPU Base: Analog Input Module Slot-Dependent V-memory Locations								
Slot	0	1	2	3	4	5	6	7
No. of Channels	V7660	V7661	V7662	V7663	V7664	V7665	V7666	V7667
Storage Pointer	V7670	V7671	V7672	V7673	V7674	V7675	V7676	V7677

The Table below applies to the D2-250-1, D2-260 or D2-262 CPU base 1.

Expansion Base D2-CM #1: Analog Input Module Slot-Dependent V-memory Locations								
Slot	0	1	2	3	4	5	6	7
No. of Channels	V36000	V36001	V36002	V36003	V36004	V36005	V36006	V36007
Storage Pointer	V36010	V36011	V36012	V36013	V36014	V36015	V36016	V36017

The Table below applies to the D2-250-1, D2-260 or D2-262 CPU base 2.

Expansion Base D2-CM #2: Analog Input Module Slot-Dependent V-memory Locations								
Slot	0	1	2	3	4	5	6	7
No. of Channels	V36100	V36101	V36102	V36103	V36104	V36105	V36106	V36107
Storage Pointer	V36110	V36111	V36112	V36113	V36114	V36115	V36116	V36117

The Table below applies to the D2-260 and D2-262 CPU base 3.

Expansion Base D2-CM #3: Analog Input Module Slot-Dependent V-memory Locations								
Slot	0	1	2	3	4	5	6	7
No. of Channels	V36200	V36201	V36202	V36203	V36204	V36205	V36206	V36207
Storage Pointer	V36210	V36211	V36212	V36213	V36214	V36215	V36216	V36217

The Table below applies to the D2-260 and D2-262 CPU base 4.

Expansion Base D2-CM #4: Analog Input Module Slot-Dependent V-memory Locations								
Slot	0	1	2	3	4	5	6	7
No. of Channels	V36300	V36301	V36302	V36303	V36304	V36305	V36306	V36307
Storage Pointer	V36310	V36311	V36312	V36313	V36314	V36315	V36316	V36317

Negative Temperature Readings with Magnitude Plus Sign (Pointer Method) for the D2-240, D2-250-1, D2-260 or D2-262 CPUs

With bipolar ranges, some additional logic will be needed to determine whether the value being returned represents a positive voltage or a negative voltage. For example, the direction for a motor might need to be known. There is a solution for this:

- If bipolar ranges are used and a value greater than or equal to 8000hex is obtained, the value is negative.
- If a value less than or equal to 7FFFhex is obtained, then the value is positive.

The sign bit is the most significant bit, which combines 8000hex to the data value. If the value is greater than or equal to 8000hex, only the most significant bit and the active channel bits need to be masked to determine the actual data value.



NOTE: D2-240 CPUs with firmware release version 2.5 or later and D2-250 CPUs with firmware release version 1.06 or later support this method. Use the D2-230 multiplexing example if your firmware is an earlier version.

The two programs on the next page show how this can be accomplished. The first example uses magnitude plus sign (binary) and the second example uses magnitude plus sign (BCD). The examples only show two channels.

It is good to know when a value is negative, so these rungs should be placed before any other operations that use the data, such as math instructions, scaling operations, etc. Also, if stage programming instructions are being used, these rungs should be in a stage that is always active.



NOTE: This logic is only needed for each channel that is using bipolar input signals.

Magnitude Plus Sign (Binary)

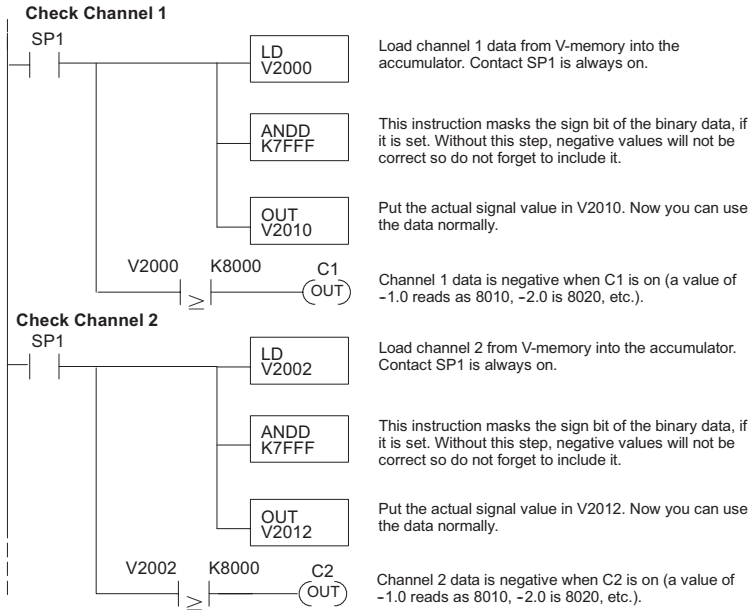

Magnitude Plus Sign (BCD)

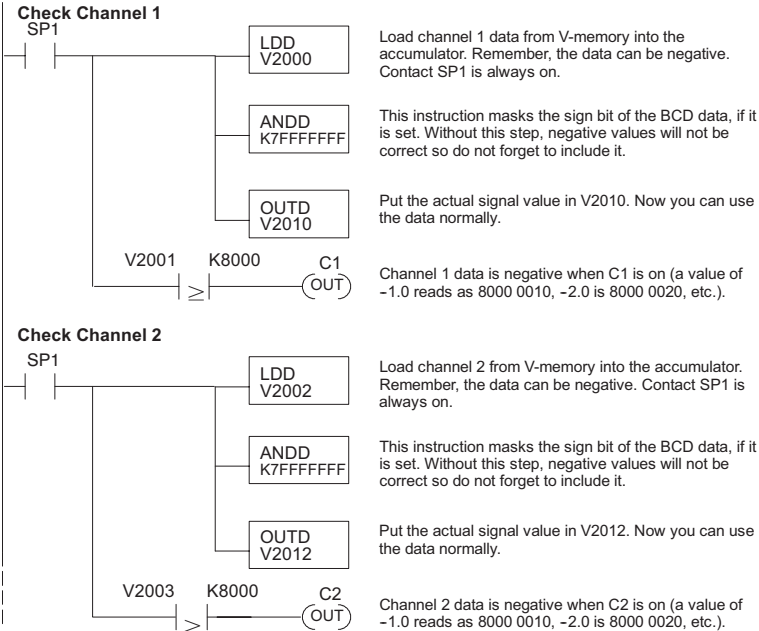

Negative Temperatures 2's Complement (Binary/Pointer Method) for the D2-240, D2-250-1, D2-260 or D2-262 CPUs

The 2's complement mode is used for negative temperature display purposes, while at the same time using the magnitude plus sign of the temperature in a control program. The DirectSoft element Signed Decimal is used to display negative numbers in 2's complement form. To find the absolute value of a negative number in 2's complement, invert the number and add 1 as shown in the following example.

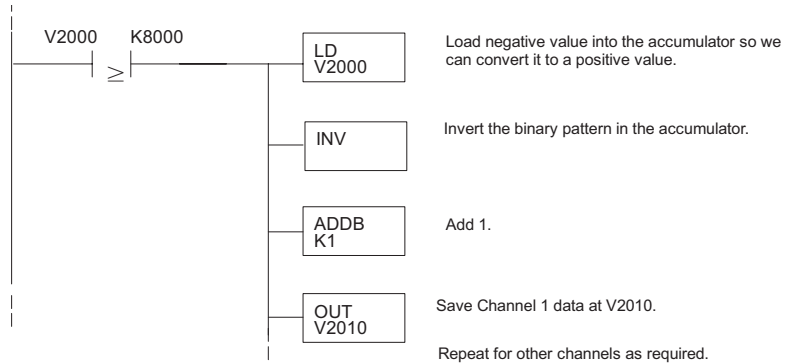

Understanding the Input Assignments (Multiplexing Ladder Only)

Remember that this module appears to the CPU as a 32-point discrete input module. Use these points to obtain:

- An indication of which channel is active
- The digital representation of the analog signal
- Module diagnostic information

Since all input points are automatically mapped into V-memory, it is easy to determine the location of the data word that will be assigned to the module.

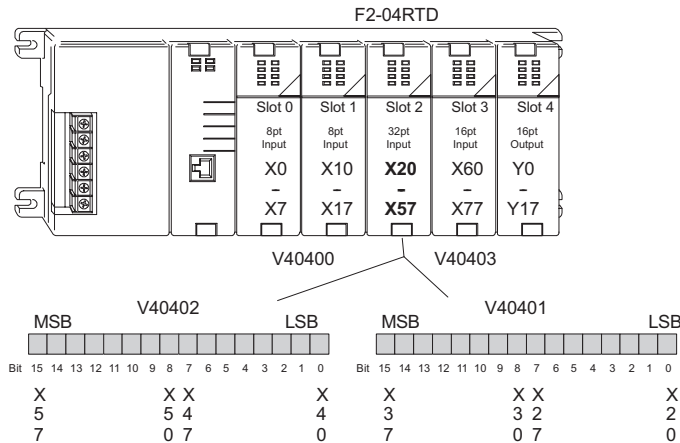

Chapter 6: F2-04RTD 4-Channel RTD Input

When a D2-230 CPU is used, the input points must start on a V-memory boundary. To use the V-memory references required for a D2-230 CPU, refer to the table below. The first input address assigned to a module must be one of the X inputs shown. The table also shows the V-memory addresses that correspond to these X inputs.

X	X0	X20	X40	X60	X100	X120	X140	X160
V	V40400	V40401	V40402	V40403	V40404	V40405	V40406	V40407

Analog Data Bits

The first 16 bits represent the analog data in binary format.

Bit	Value	Bit	Value
0	1	8	256
1	2	9	512
2	4	10	1024
3	8	11	2048
4	16	12	4096
5	32	13	8192
6	64	14	16384
7	128	15	32768

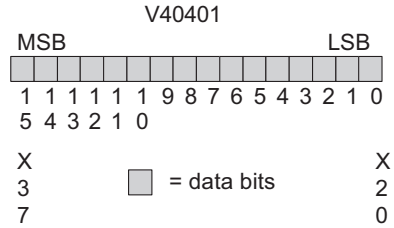

Active Channel Bits

The active channel bits represent the multiplexed channel selections in binary format.

Bit 1	Bit 0	Channel
0	0	1
0	1	2
1	0	3
1	1	4

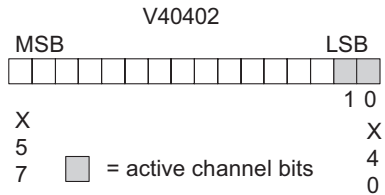

Broken Transmitter Bits (Multiplexing Ladder Methods)

The broken transmitter bits are on when the corresponding RTD is open.



NOTE: The broken transmitter bits only function using the Multiplexing method.

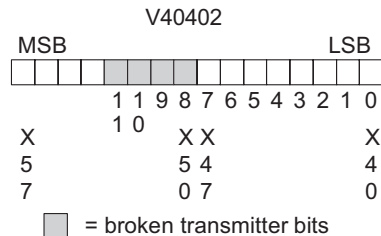

Reading Magnitude Plus Sign Values (Multiplexing)

The D2-230 CPU does not have the special V-memory locations that allows for automatic management of the data transfer. Since all channels are multiplexed into a single data word, the control program must be set up to determine which channel is being read. Since the module appears as X input points to the CPU, it is very easy to use the active channel status bits to determine which channel is being monitored.



NOTE: D2-230 CPUs with firmware release version 1.6 or later required for multiplexing ladder.

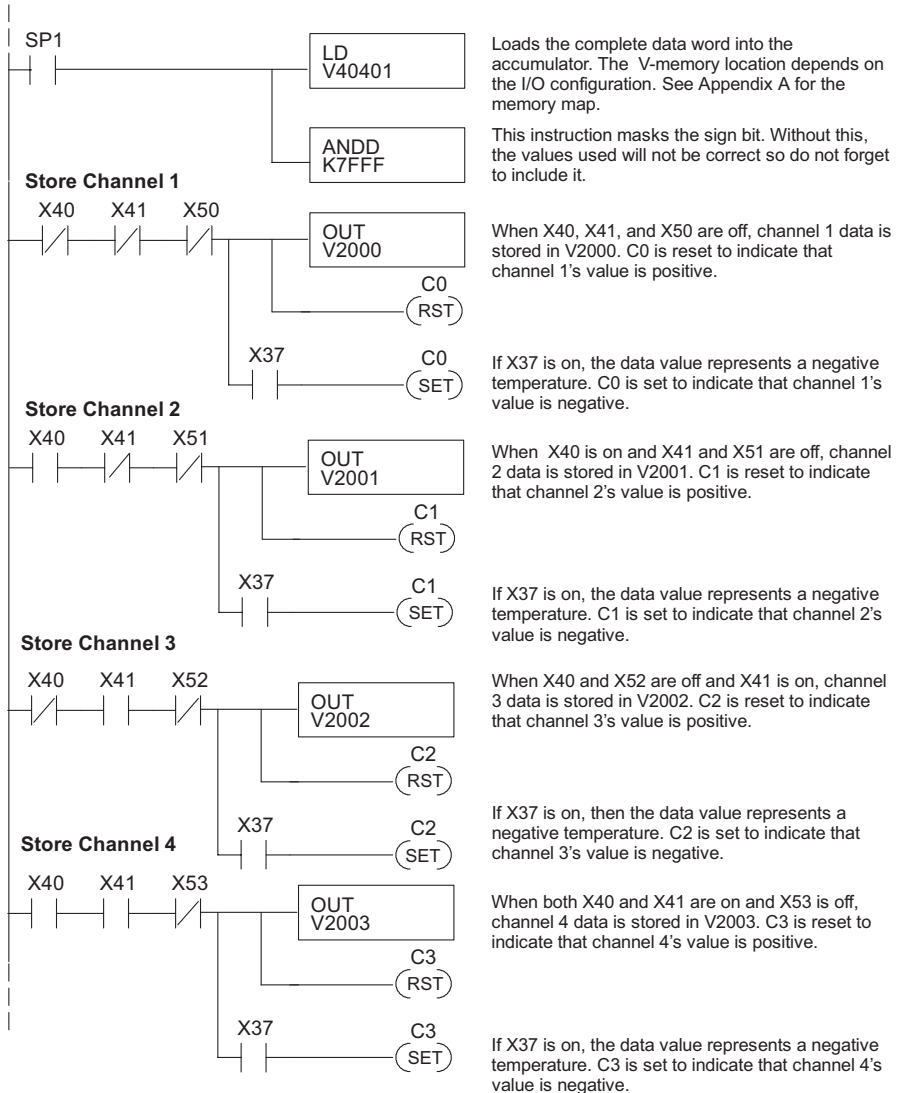

Reading 2's Complement Values (Multiplexing)

The D2-230 CPU does not have the special V-memory locations that allows for automatic management of the data transfer. Since all channels are multiplexed into a single data word, the control program must be set up to determine which channel is being read. Since the module appears as X input points to the CPU, it is very easy to use the active channel status bits to determine which channel is being monitored. The 2's complement data format may be required to correctly display bipolar data on some operator interfaces. This data format could also be used to simplify averaging a bipolar signal. To view this data format in DirectSOFT, select Signed Decimal.

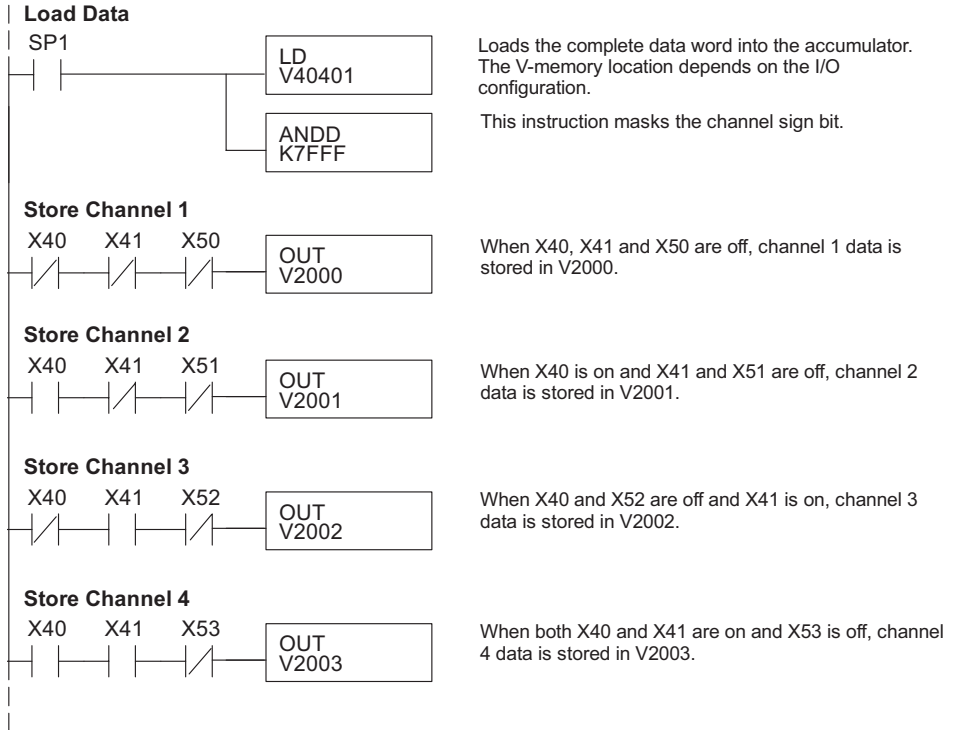

Scaling the Input Data

No scaling of the input temperature is required. The readings directly reflect the actual temperatures. For example: a reading of 8482 is 848.2°C, a reading of 16386 is -0.2°C (magnitude plus sign) and a reading of 32770 is -0.2° (2's complement).

Filtering Input Noise (D2-250-1, D2-260 and D2-262 CPUs Only)

Add the following logic to filter and smooth analog input noise in D2-250-1, D2-260 and D2-262 CPUs. This is especially useful when using PID loops. Noise can be generated by the field device and/or induced by field wiring.

In the following example, the analog value in BCD is first converted to a binary number. Memory location V1400 is the designated workspace in this example. The MULR instruction is the filter factor, which can be from 0.1–0.9. The example uses 0.2. Using a smaller filter factor increases filtering. A higher precision value can be used, but it is not generally needed. The filtered value is then converted back to binary and then to BCD. The filtered value is stored in location V1402 for use in the application program or a PID loop.



NOTE 1: Please review intelligent instructions (IBox) in Chapter 5 of D2-USER-M, which simplify this and other functions. The IBox instructions are supported by the D2-250-1, D2-260 and D2-262.

NOTE 2: Be careful not to do a multiple number conversion on a value. For example, if the pointer method is used to get the analog value, it is in BCD and must be converted to binary. However, if the conventional method of reading analog is used and the first 15 bits are masked, the value is already in binary and no conversion is needed. Also, if the conventional method is used, change the LDD V2000 instruction to LD V2000.

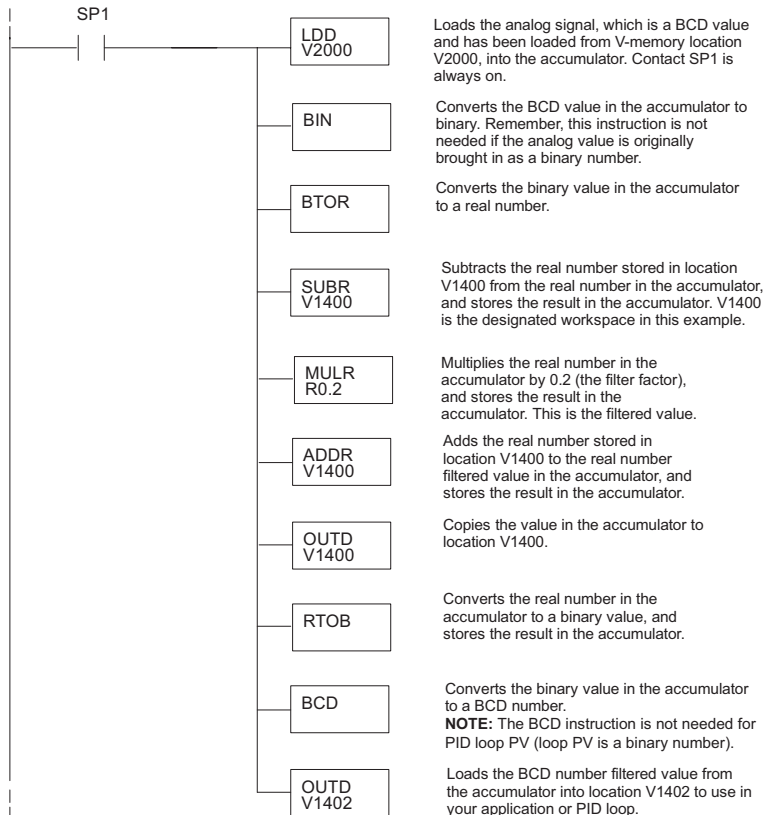

F2-04THM 4-CHANNEL THERMOCOUPLE INPUT



In This Chapter...

Module Specifications	7-2
Setting the Module Jumpers	7-6
Connecting the Field Wiring	7-9
Module Operation	7-13
Writing the Control Program	7-15

Module Specifications

The F2-04THM, 4-Channel Thermocouple Input Module provides the following features and benefits:

- Four thermocouple input channels with 16-bit voltage resolution or 0.1°F/°C temperature resolution.
- Automatically converts type E, J, K, R, S, T, B, N, or C thermocouple signals into direct temperature readings. No extra scaling or complex conversion is required.
- Temperature data can be expressed in °F or °C.
- Module can be configured as $\pm 5V$, $\pm 156mV$, 0–5V, 0–156mV input and will convert volts and millivolt signal levels into 16-bit digital (0–65535) values.
- Signal processing features include automatic cold junction compensation, thermocouple linearization, and digital filtering.
- The temperature calculation and linearization are based on data provided by the National Institute of Standards and Technology (NIST).
- Diagnostic features include detection of thermocouple burn-out or disconnection.

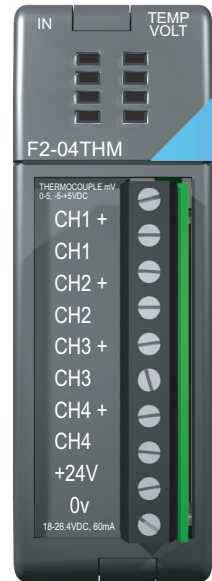

Chapter 7: F2-04THM, 4-Channel Thermocouple Input

The following tables provide the specifications for the F2-04THM Analog Input Module. Review these specifications to make sure the module meets your application requirements.

General Specifications	
Number of Channels	4, differential
Common Mode Range	±5VDC
Common Mode Rejection	90dB min. @ DC, 150dB min. @ 50/60Hz.
Input Impedance	1MΩ min.
Absolute Maximum Ratings	Fault-protected inputs to ±50VDC
Accuracy vs. Temperature	±5ppm/°C maximum; full scale calibration (including maximum offset change)
Sampling Rate	All 4 channels: 1.4 seconds (*5.4 seconds)
PLC Update Rate	4 channels per scan max. (D2-240, D2-250-1, D2-260 and D2-262 CPU) 1 channel per scan, max. D2-230 CPU
Digital Inputs	16 binary data bits, 2 channel ID bits, 4 diagnostic bits
Input Points Required	32 point (X) input module
Power Budget Requirement	80mA (*100mA) maximum, 5VDC (supplied by base)
External Power Supply	40 mA, 10-30 VDC (*60 mA, 18-26.4 VDC)
Operating Temperature	0–60°C (32–140°F)
Storage Temperature	-2°C to 70°C (-4°F to 158°F)
Relative Humidity	5–95% (non-condensing)
Environmental air	No corrosive gases permitted
Vibration	MIL STD 810C 514.2
Shock	MIL STD 810C 516.2
Noise Immunity	NEMA ICS3-304

Thermocouple Specifications		
Input Ranges	Type J	-190–760°C (-310–1400°F)
	Type K	-150–1372°C (-238–2502°F)
	Type E	-210–1000°C (-346–1832°F)
	Type R	65–1768°C (149–3214°F)
	*Type R	65–1768°C (149–3214°F)
	Wide	
	Type S	65–1768°C (149–3214°F)
	Type T	-230–400°C (-382–752°F)
	Type B	529–1820°C (984–3308°F)
	Type N	-70–1300°C (-94–2372°F)
Type C	65–2320°C (149–4208°F)	
Display Resolution	±0.1°C or ±0.1°F	
Cold Junction Compensation	Automatic	
Warm-Up Time	30 minutes typically ±1°C repeatability	
Linearity Error (End to End)	±1°C maximum, ±0.5°C typical	
Maximum Inaccuracy	±3°C (excluding thermocouple error)	

NOTE: *R Wide range is available only on modules with date code 0410E2 and later.

NOTE: Values in parenthesis with an asterisk are for older modules with two circuit board design and date codes 0806E1 or previous. Values not in parenthesis are for single circuit board models with date code 0806E1 and above.



Voltage Input Specifications	
Voltage Ranges	Voltage: 0-5V, $\pm 5V$, 0-156.25 mV, ± 156.25 mVDC,
Resolution	16 bit (1 in 65535)
Full Scale Calibration Error (Offset Error Included)	± 13 count typical, ± 33 maximum
Offset Calibration Error	± 1 count maximum @ 0V input
Linearity Error (End to End)	± 1 count maximum
Maximum Inaccuracy	$\pm 0.02\%$ @ 25°C (77°F)

Module Calibration

The F2-04THM module requires no calibration. The module automatically calibrates every five seconds, which removes offset and gain errors. For each thermocouple type, the temperature calculation and linearization performed by the microprocessor is accurate to within 0.01°C.

Thermocouple Input Configuration Requirements

The F2-04THM temperature input module requires 32 discrete input points. The module can be installed in any slot of a DL205 system. The limitations on the number of analog modules are:

- For local and local expansion systems, the available power budget and number of discrete I/O points.
- For remote I/O systems, the available power budget and number of remote I/O points.

Check the user manual for the particular model of CPU and I/O base being used for more information regarding power budget and number of local, local expansion or remote I/O points.

Special Placement Requirements (D2-230 and Remote I/O Bases)

It is important to examine the configuration if a D2-230 CPU is being used. As can be seen in the section on Writing the Control Program, V-memory locations are used to manage the analog data. If the module is placed in a slot so that the input points do not start on a V-memory boundary, the program instructions aren't able to access the data. This also applies when placing this module in a remote base using a D2-RSSS in the CPU slot.

Correct!

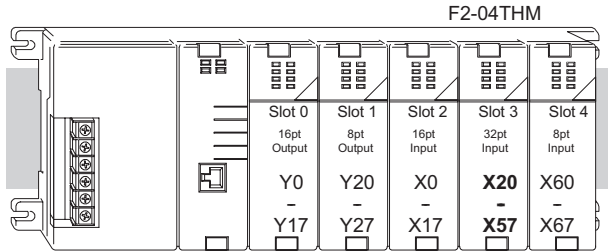

Data is correctly entered, so input points start on a V-memory boundary address as in the table graphic below. V40400 | V40403
V40401 - V40402

MSB			V40402			LSB			MSB			V40401			LSB		
X			X	X		X			X			X	X				X
5			5	4		4			3			3	2				2
7			0	7		0			7			0	7				0

Incorrect

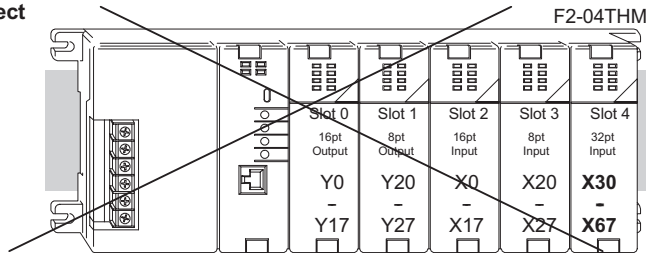

Data is split over three locations, (see graphic below) so instructions cannot access data from a D2-230 CPU.

MSB			V40403			LSB			MSB			V40402			LSB			MSB			V40401			LSB		
X			X	X		X			X			X	X		X			X			X	X				X
7			7	6		6			5			5	4		4			3			3	2				2
7			0	7		0			7			0	7		0			7			0	7				0

V-memory references required for a D2-230 CPU, the first input address assigned to the module must be one of the following X locations. The corresponding V-memory addresses for the X locations are shown below.

X	X0	X20	X40	X60	X100	X120	X140	X160
V	V40400	V40401	V40402	V40403	V40404	V40405	V40406	V40407

Setting the Module Jumpers

Jumper Locations

Use the figures below to locate the single jumper (J9) and the bank of eight jumpers (J7) on the PC board. Notice that the PC board was re-designed starting with date code 0806E1 and the jumper locations changed; the functionality of the jumpers did not change. To prevent losing a jumper when it is removed, store it in its original location by sliding one of its sockets over a single pin. The following options can be selected by installing or removing the appropriate jumpers:

- Number of channels
- Input type
- Conversion unit
- Calibrate enable

Calibrate Enable

Jumper locations for modules having date code prior to 0806E1.

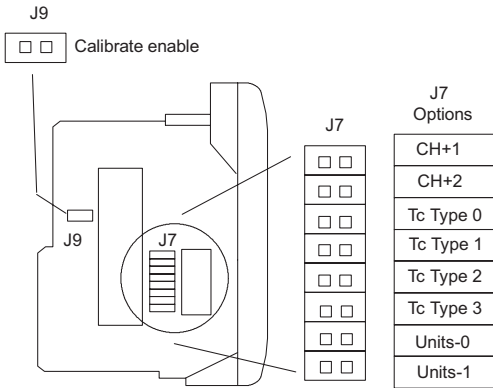

Jumper locations for modules having date code 0806E1 and later.

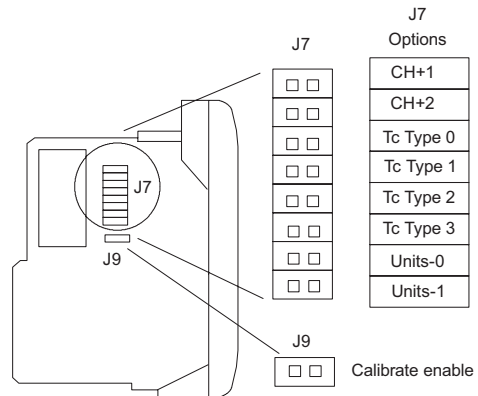

Locate the “Calibrate enable” jumper J9.

The jumper comes from the factory with the jumper removed (the jumper is installed on one of the two pins only). Installing this jumper disables the thermocouple active burn-out detection circuitry, which enables a thermocouple calibrator to be attached to the module.

To be certain that the output of the thermocouple calibrator is within the 5V common mode voltage range of the module, connect the negative side of the differential voltage input channel to the 0V terminal, then connect the thermocouple calibrator to the differential inputs (for example, Ch 3+ and Ch 3).

For the voltage input ranges, this jumper is inactive and can be installed or removed with no effect on voltage input.

Selecting the Number of Channels

The top two J7 jumpers labeled CH+1 and CH+2 determine the number of channels that will be used. The table shows how to set the jumpers for channels 1 to 4. The module comes with both jumpers installed for four channel operation. For example, to select channels 1 to 3, leave the CH+2 jumper installed and remove the CH+1 jumper. Any unused channels are not processed. For example, if channels 1 to 3 are selected, channel 4 will not be active.

X = jumper installed
Blank space = jumper removed

Number of Channels	Jumper	
	CH+1	CH+2
1	–	–
2	X	–
3	–	X
4	X	X

Setting Input Type

The next four jumpers, Tc Type 0, Tc Type 1, Tc Type 2, and Tc Type 3, must be set to match either the type of thermocouple being used or the input voltage level. Since the module can be used with many types of thermocouples, use the table below to determine the proper settings for the thermocouple being used.

The module comes from the factory with all four jumpers installed for use with a J type thermocouple. To use a K type thermocouple, remove the jumper labeled Tc Type 0.



NOTE: All channels of the module must be the same thermocouple type or voltage range.

X = Jumper installed, and blank space = Jumper removed.

Thermocouple/ Voltage Inputs	Jumper			
	Tc Type 0	Tc Type 1	Tc Type 2	Tc Type 3
J	X	X	X	X
K	–	X	X	X
E	X	–	X	X
R	–	–	X	X
R Wide*	–	X	–	–
S	X	X	–	X
T	–	X	–	X
B	X	–	–	X
N	–	–	–	X
C	X	X	X	–
0–5V	–	X	X	–
±5V	X	–	X	–
0–156 mV	–	–	X	–
±156 mV	X	X	–	–



***NOTE:** R Wide is only available on modules with date code 0410E2 and later.

Selecting the Conversion Units

Use the last two jumpers, Units-0 and Units-1, to set the conversion unit used for either thermocouple or voltage inputs. The options are magnitude plus sign or 2's complement, plus Fahrenheit or Celsius for thermocouples. See the next two sections for jumper settings when using either thermocouple or voltage inputs.

Thermocouple Conversion Units

All thermocouple types are converted into a direct temperature reading in either Fahrenheit or Celsius. The data contains one implied decimal place. For example, a value in V-memory of 1002 would be 100.2°F or °C.

For thermocouple ranges which include negative temperatures (J,E,K,T,N), the display resolution is from -3276.7 to +3276.7. For positive-only thermocouple ranges (R,S,B,C), the display resolution is 0 – 6553.5.

Negative temperatures can be represented in either 2's complement or magnitude plus sign form. If the temperature is negative, the most significant bit in the V-memory location is set (X17, if the starting address for the module is X0).

The 2's complement data format may be required to correctly display bipolar data on some operator interfaces. This data format could also be used to simplify averaging a bipolar signal. To view this data format in DirectSoft, select Signed Decimal.

For unipolar thermocouple ranges (R,S,B,C), it does not matter if magnitude plus sign or 2's complement is selected.

Use the table to select settings. The module comes with both jumpers installed for magnitude plus sign conversion in Fahrenheit. For example, remove the Units-0 jumper and leave the Units-1 jumper installed for magnitude plus sign conversion in Celsius.

X = Jumper installed, and
blank space = Jumper removed.

Number of Channels	Temperature Conversion Units			
	Magnitude + Sign		2's Complement	
	°F	°C	°F	°C
Units-0	X	–	X	–
Units-1	X	X	–	–

Voltage Conversion Units

The bipolar voltage input ranges, 5V or 156mV (see previous page for 5V and 156mV settings), may be converted to a 15-bit magnitude plus sign or a 16-bit 2's complement value.

Use the table to select settings. The module comes with both jumpers installed for magnitude plus sign conversion. Remove the Units-1 jumper and leave the Units-0 jumper installed for 2's complement conversion.

X = Jumper installed, and
blank space = Jumper removed.

Jumper Pins	Voltage Conversion Units	
	Magnitude Plus Sign	2's Complement
Units-0	X	X
Units-1	X	–



NOTE: When selecting a Unipolar Voltage mode (0-5V, 0-156mV), BCD data type will not give a correct reading. Decimal data type should always be used for Unipolar Voltage modes.

Connecting the Field Wiring

Wiring Guidelines

Your company may have guidelines for wiring and cable installation. If so, check the guidelines before beginning the installation. Here are some general things to consider:

- Use the shortest wiring route whenever possible.
- Use shielded wiring and ground the shield at the transmitter source. Do not ground the shield at both the module and the source.
- Do not run the signal wiring next to large motors, high current switches, or transformers. This may cause noise problems.
- Route the wiring through an approved cable housing to minimize the risk of accidental damage. Check local and national codes to choose the correct method for your application.

User Power Supply Requirements

The F2-04THM module requires at least one field-side power supply. The same or separate power sources can be used for the 0–5 V or 0–156 mV transmitter voltage supply. The module requires 10–30 VDC, at 40mA, from the external power supply.

The DL205 AC bases have a built-in 24VDC power supply that provide up to 300mA of current. This can be used instead of a separate supply. Check the power budget to be safe.

It is desirable in some situations to power the transmitters separately in a location remote from the PLC. This will work as long as the transmitter supply meets the voltage and current requirements, and the transmitter's minus (-) side and the module supply's minus (-) side are connected together.



WARNING: If the internal 24VDC power budget is exceeded, it may cause unpredictable system operation that can lead to a risk of personal injury or equipment damage.

The DL205 base has a switching type power supply. As a result of switching, noise may cause some instability into the analog input data if the base power supply is used. If this is unacceptable, try one of the following:

1. Use a separate linear power supply.
2. Connect the 24VDC common to the frame ground, which is the screw terminal marked "G" on the base.

Unused temperature inputs should be shorted together and connected to common.

Thermocouples

Use shielded thermocouples whenever possible to minimize the presence of noise on the thermocouple wire. Ground the shield wire at one end only. For grounded thermocouples, connect the shield at the sensor end. For ungrounded thermocouples, connect the shield to the 0V (common) terminal.

Grounded Thermocouple Assembly

A grounded thermocouple provides better response time than an ungrounded thermocouple because the tip of the thermocouple junction is in direct contact with the protective case.

Ungrounded Thermocouple Assembly

An ungrounded thermocouple is electrically isolated from the protective case. If the case is electrically grounded it provides a low-impedance path for electrical noise to travel. The ungrounded thermocouple provides a more stable and accurate measurement in a noisy environment.

Exposed Grounded Thermocouple

The thermocouple does not have a protective case and is directly connected to a device with a higher potential. Grounding the thermocouple assures that the thermocouple remains within the common mode specifications. Because a thermocouple is essentially a wire, it provides a low-impedance path for electrical noise. The noise filter has a response of > 100dB @ 50/60 Hz.



WARNING: A thermocouple can become shorted to a high voltage potential. Because common terminals are internally connected together, whatever voltage potential exists on one thermocouple will exist on the other channels.

Ambient Variations in Temperature

The F2-04THM module has been designed to operate within the ambient temperature range of 0 to 60°C.

The cold junction compensation is calibrated to operate in a still-air environment. If the module is used in an application that has forced convection cooling, an error of 2 to 3°C may be introduced. To compensate for this, ladder logic can be used to correct the values.

When configuring the system design it is best to locate any heat-producing devices above and away from the PLC chassis because the heat will affect the temperature readings. For example, heat introduced at one end of the terminal block can cause a channel-to-channel variation.

When exposing the F2-04THM module to abrupt ambient temperature changes it will take several minutes for the cold junction compensation and terminal block to stabilize. Errors introduced by abrupt ambient temperature changes will be less than 4°C.

Wiring Diagrams

Use the following diagrams to connect the field wiring.

Thermocouple Input Wiring Diagram

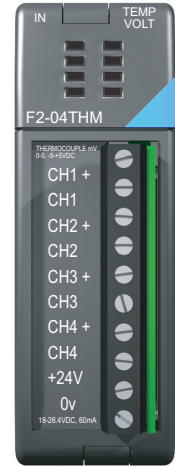
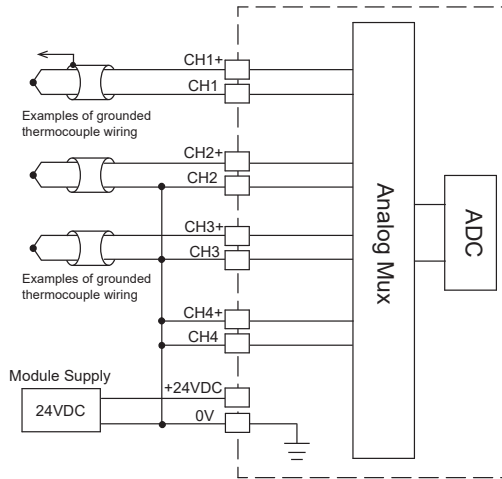

NOTE: Terminate shields at the respective signal source. Also, connect unused channels to a common terminal (0V, CH4+, CH4).

Voltage Input Wiring Diagram

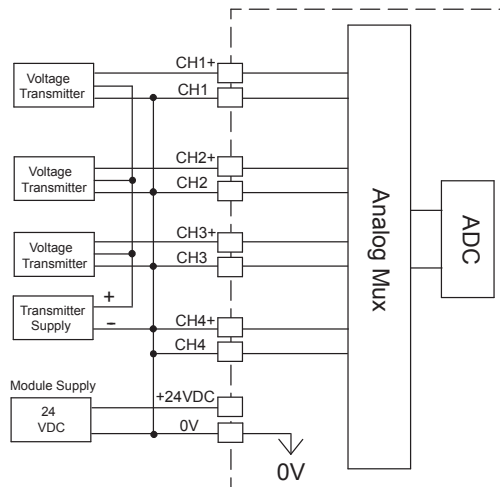

NOTE: Connect unused channels to a common terminal (0V, CH4+, CH4). Also, when using 0-156 mV and 5V ranges, connect (-) or 0V terminals (CH1, CH2, CH3, CH4) to 0V module supply terminal to ensure common mode acceptance.

Chapter 7: F2-04THM, 4-Channel Thermocouple Input

With grounded thermocouples, take precautions to prevent having a voltage potential between thermocouple tips. A voltage of 1.25V or greater between tips will skew measurements.

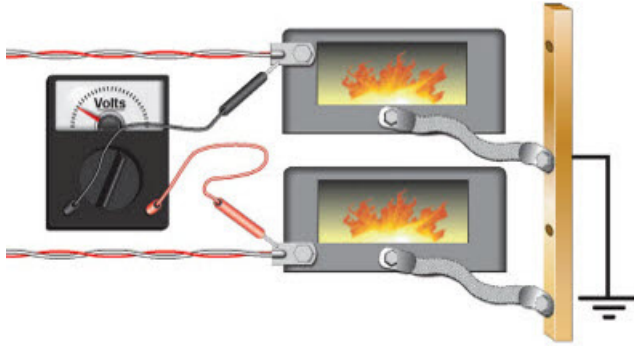

Module Operation

Before beginning to write the control program, it is important to take a few minutes to understand how the module processes the analog signals.

Channel Scanning Sequence (Multiplexing) for a D2-230 CPU

The F2-04THM module can supply different amounts of data per scan, depending on the type of CPU being used. The D2-230 can obtain one channel of data per CPU scan. Since there are four channels, it can take up to four scans to get data for all channels. Once all channels have been scanned the process starts over with channel 1. Unused channels are not processed, so if only two channels are selected, each channel will be updated every other scan. The multiplexing method can also be used for the D2-240, D2-250-1, D2-260 or D2-262 CPUs.

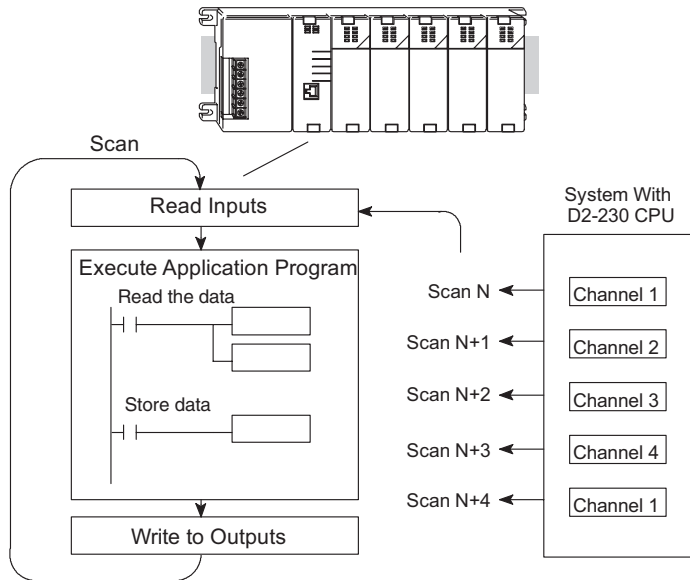

Channel Scanning Sequence (Pointer Method) for D2-240, D2-250-1, D2-260 and D2-262 CPUs

If a D2-240, a D2-250-1, a D2-260 or a D2-262 CPU is being used, all four channels of input data can be captured in one scan. This is because the D2-240, D2-250-1, D2-260 and D2-262 CPUs support special V-memory locations that are used to manage the data transfer. This is discussed in more detail in the next section on Writing the Control Program.

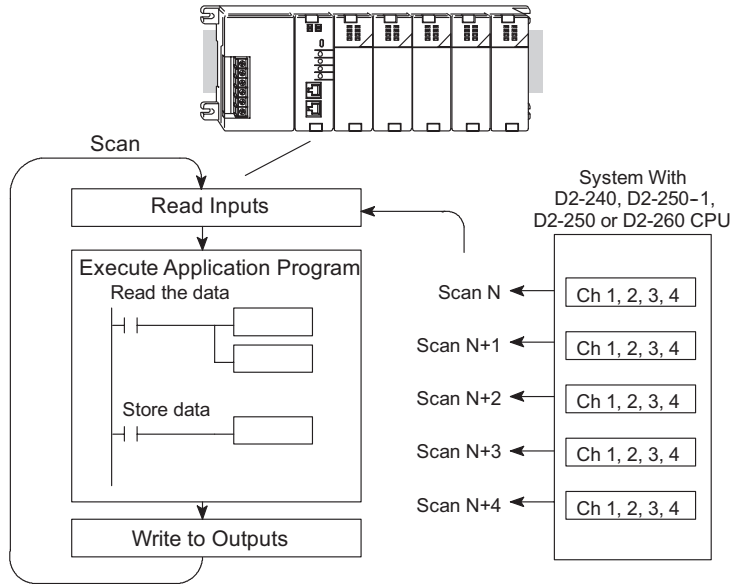

Analog Module Updates

Even though the channel updates to the CPU are synchronous with the CPU scan, the module asynchronously monitors the analog transmitter signal and converts the signal to a 16-bit binary representation. This enables the module to continuously provide accurate measurements without slowing down the discrete control logic in the RLL program.

The time required to sense the temperature and copy the value to V-memory is 1.4 seconds for a single board design module (5.4 seconds for a two board design module) plus 1 scan time maximum.

Writing the Control Program

Reading Values Pointer Method and Multiplexing

There are two methods of reading values:

- Pointer method
- Multiplexing

The multiplexing method must be used with a D2-230 CPU. The multiplexing method must also be used with remote I/O modules (the pointer method will not work). Either method can be used with the D2-240, D2-250-1, D2-260 and D2-262 CPUs, but for ease of programming it is highly recommended to use the pointer method.

Pointer Method for the D2-240, D2-250-1, D2-260 and D2-262 CPUs

The CPU has special V-memory locations (shown in tables on the following page) assigned to each base slot that greatly simplifies the programming requirements. These V-memory locations allow you to:

- Specify the data format
- Specify the number of channels to scan
- Specify the storage locations

The example program shows how to setup these locations. Place this rung anywhere in the ladder program, or in the initial stage if stage programming instructions are used. This is all that is required to read the data into V-memory locations. Once the data is in V-memory, math instructions can be used on the data, compare the data against preset values, etc. V2000 is used in the example, but any user V-memory location can be used. The module is installed in slot 2 for the examples. Use the V-memory locations shown in the application. The pointer method automatically converts values to BCD.



NOTE: D2-240 CPUs with firmware release version 2.5 or later and D2-250 CPUs with firmware release version 1.06 or later support this method. Use the D2-230 multiplexing example if the firmware revision is earlier.

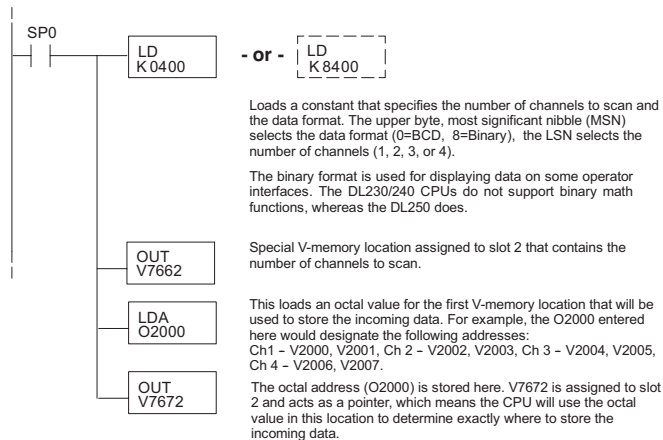

Chapter 7: F2-04THM, 4-Channel Thermocouple Input

The following tables show the special V-memory locations used by the D2-240, D2-250-1, D2-260 and D2-262 for the CPU base and local expansion base I/O slots. Slot 0 (zero) is the module next to the CPU or D2-CM module. Slot 1 is the module two places from the CPU or D2-CM, and so on. Remember, the CPU only examines the pointer values at these locations after a mode transition. Also, if the D2-230 (multiplexing) method is used, verify that these addresses in the CPU are 0 (zero).

The Table below applies to the D2-240, D2-250-1, D2-260 and D2-262 CPU base.

CPU Base: Analog Input Module Slot-Dependent V-memory Locations								
Slot	0	1	2	3	4	5	6	7
No. of Channels	V7660	V7661	V7662	V7663	V7664	V7665	V7666	V7667
Storage Pointer	V7670	V7671	V7672	V7673	V7674	V7675	V7676	V7677

The Table below applies to the D2-250-1, D2-260 and D2-262 CPU base 1.

Expansion Base D2-CM #1: Analog Input Module Slot-Dependent V-memory Locations								
Slot	0	1	2	3	4	5	6	7
No. of Channels	V36000	V36001	V36002	V36003	V36004	V36005	V36006	V36007
Storage Pointer	V36010	V36011	V36012	V36013	V36014	V36015	V36016	V36017

The Table below applies to the D2-250-1, D2-260 and D2-262 CPU base 2.

Expansion Base D2-CM #2: Analog Input Module Slot-Dependent V-memory Locations								
Slot	0	1	2	3	4	5	6	7
No. of Channels	V36100	V36101	V36102	V36103	V36104	V36105	V36106	V36107
Storage Pointer	V36110	V36111	V36112	V36113	V36114	V36115	V36116	V36117

The Table below applies to the D2-260 and D2-262 CPU base 3.

Expansion Base D2-CM #3: Analog Input Module Slot-Dependent V-memory Locations								
Slot	0	1	2	3	4	5	6	7
No. of Channels	V36200	V36201	V36202	V36203	V36204	V36205	V36206	V36207
Storage Pointer	V36210	V36211	V36212	V36213	V36214	V36215	V36216	V36217

The Table below applies to the D2-260 and D2-262 CPU base 4.

Expansion Base D2-CM #4: Analog Input Module Slot-Dependent V-memory Locations								
Slot	0	1	2	3	4	5	6	7
No. of Channels	V36300	V36301	V36302	V36303	V36304	V36305	V36306	V36307
Storage Pointer	V36310	V36311	V36312	V36313	V36314	V36315	V36316	V36317

Negative Temperature Readings with Magnitude Plus Sign (Pointer Method) for D2-240, D2-250-1, D2-260 and D2-262 CPUs

With bipolar ranges, some additional logic will be needed to determine whether the value being returned represents a positive voltage or a negative voltage. For example, the direction for a motor might need to be known. There is a solution for this:

- If bipolar ranges are used and a value greater than or equal to 8000hex is obtained, the value is negative.
- If a value less than or equal to 7FFFhex is obtained, then the value is positive.

The sign bit is the most significant bit, which combines 8000hex to the data value. If the value is greater than or equal to 8000hex, only the most significant bit and the active channel bits need to be masked to determine the actual data value.



NOTE: D2-240 CPUs with firmware release version 2.5 or later and D2-250 CPUs with firmware release version 1.06 or later support this method. Use the D2-230 multiplexing example if your firmware is an earlier version.

The following two programs on this page and the next page show how this can be accomplished. The first example uses magnitude plus sign (binary) and the second example uses magnitude plus sign (BCD). The examples only show two channels.

It is good to know when a value is negative, so these rungs should be placed before any other operations that use the data, such as math instructions, scaling operations, etc. Also, if stage programming instructions are being used, these rungs should be in a stage that is always active.



NOTE: This logic is only needed for each channel that is using bipolar input signals.

Magnitude Plus Sign (Binary)

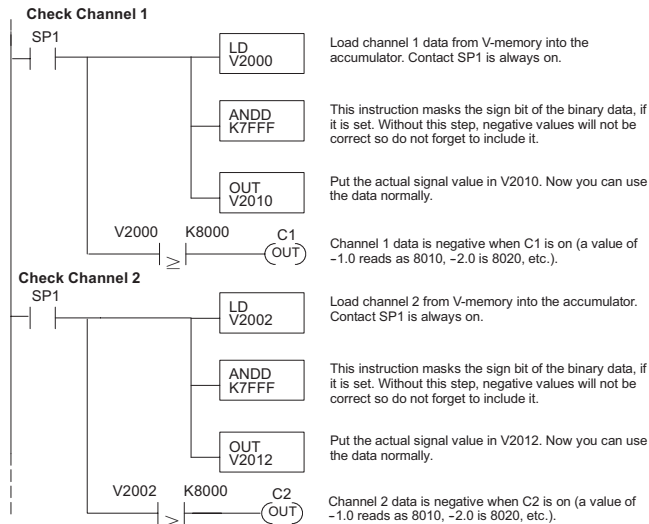

Magnitude Plus Sign (BCD)

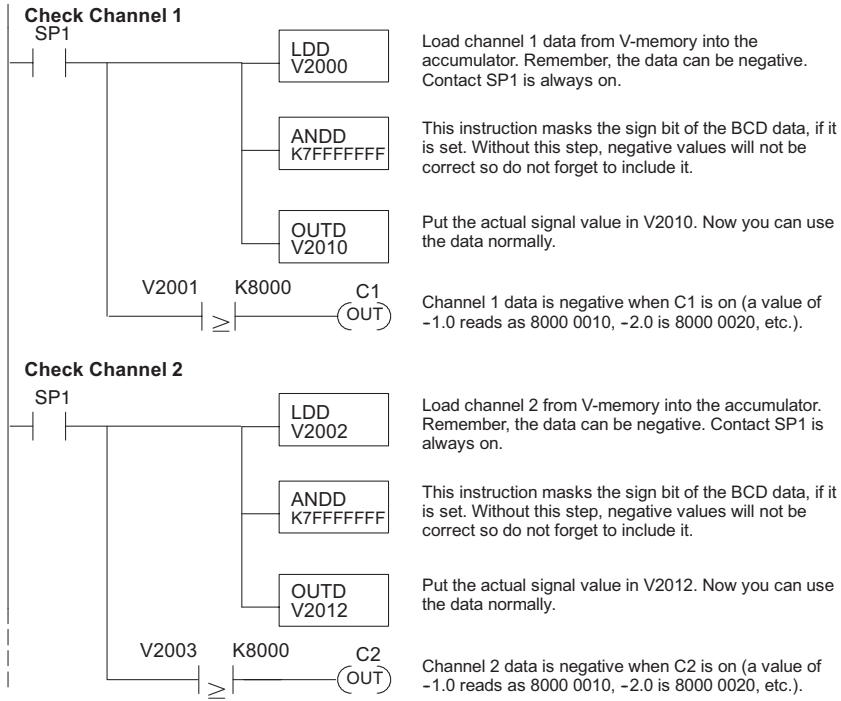

Negative Temperatures 2's Complement (Binary/Pointer Method) for D2-240, D2-250-1, D2-260 and D2-262 CPUs

The 2's complement mode is used for negative temperature display purposes, while at the same time using the magnitude plus sign of the temperature in a control program. The DirectSoft element Signed Decimal is used to display negative numbers in 2's complement form. To find the absolute value of a negative number in 2's complement, invert the number and add 1 as shown in the following example:

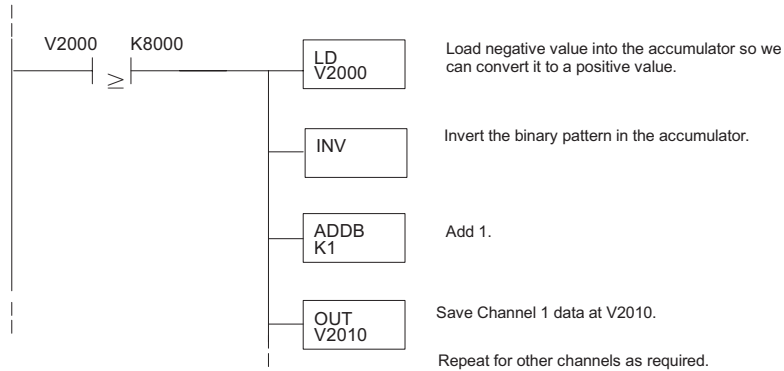

Understanding the Input Assignments (Multiplexing Ladder Only)

Remember that the F2-04THM module appears as a 32-point discrete input module to the CPU. Use these points to obtain:

- An indication of which channel is active
- The digital representation of the analog signal
- Module diagnostic information

Since all input points are automatically mapped into V-memory, it is easy to determine the location of the data word that will be assigned to the module.

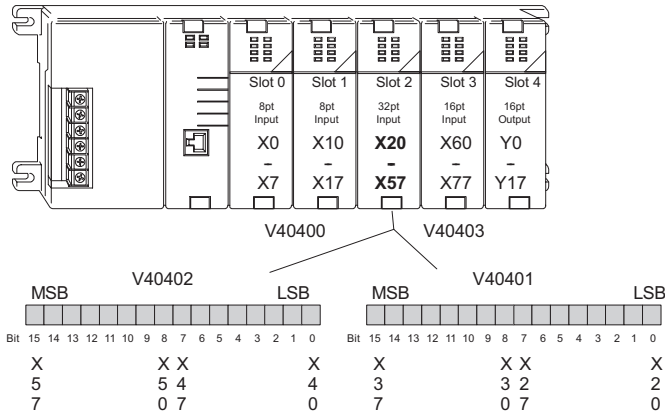

Chapter 7: F2-04THM, 4-Channel Thermocouple Input

When a D2-230 CPU is used, the input points must start on a V-memory boundary. To use the V-memory references required for a D2-230 CPU, refer to the table below. The first input address assigned to a module must be one of the X inputs shown. The table also shows the V-memory addresses that correspond to these X inputs.

X	X0	X20	X40	X60	X100	X120	X140	X160
V	V40400	V40401	V40402	V40403	V40404	V40405	V40406	V40407

Analog Data Bits

The first 16 bits represent the analog data in binary format.

Bit	Value	Bit	Value
0	1	8	256
1	2	9	512
2	4	10	1024
3	8	11	2048
4	16	12	4096
5	32	13	8192
6	64	14	16384
7	128	15	32768

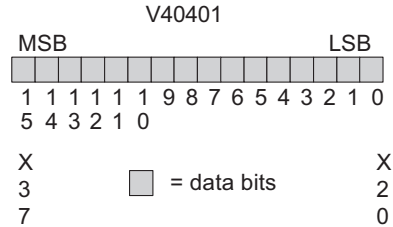

Active Channel Bits

The active channel bits represent the multiplexed channel selections in binary format.

Bit 1	Bit 0	Channel
0	0	1
0	1	2
1	0	3
1	1	4

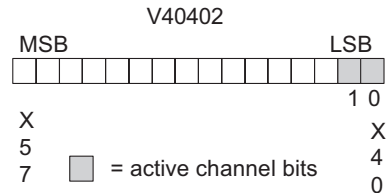

Broken Transmitter Bits (Pointer and Multiplexing Ladder Methods)

The broken transmitter bits are on when the corresponding RTD is open.

Bit	Channel
8	1
9	2
10	3
11	4

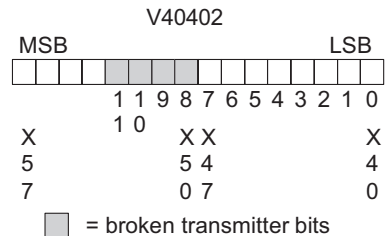

Reading Magnitude Plus Sign Values (Multiplexing)

The D2-230 CPU does not have the special V-memory locations that allows for automatic management of the data transfer. Since all channels are multiplexed into a single data word, the control program must be set up to determine which channel is being read. Since the module appears as X input points to the CPU, it is very easy to use the active channel status bits to determine which channel is being monitored.



NOTE: D2-230 CPUs with firmware release version 1.6 or later required for multiplexing ladder.

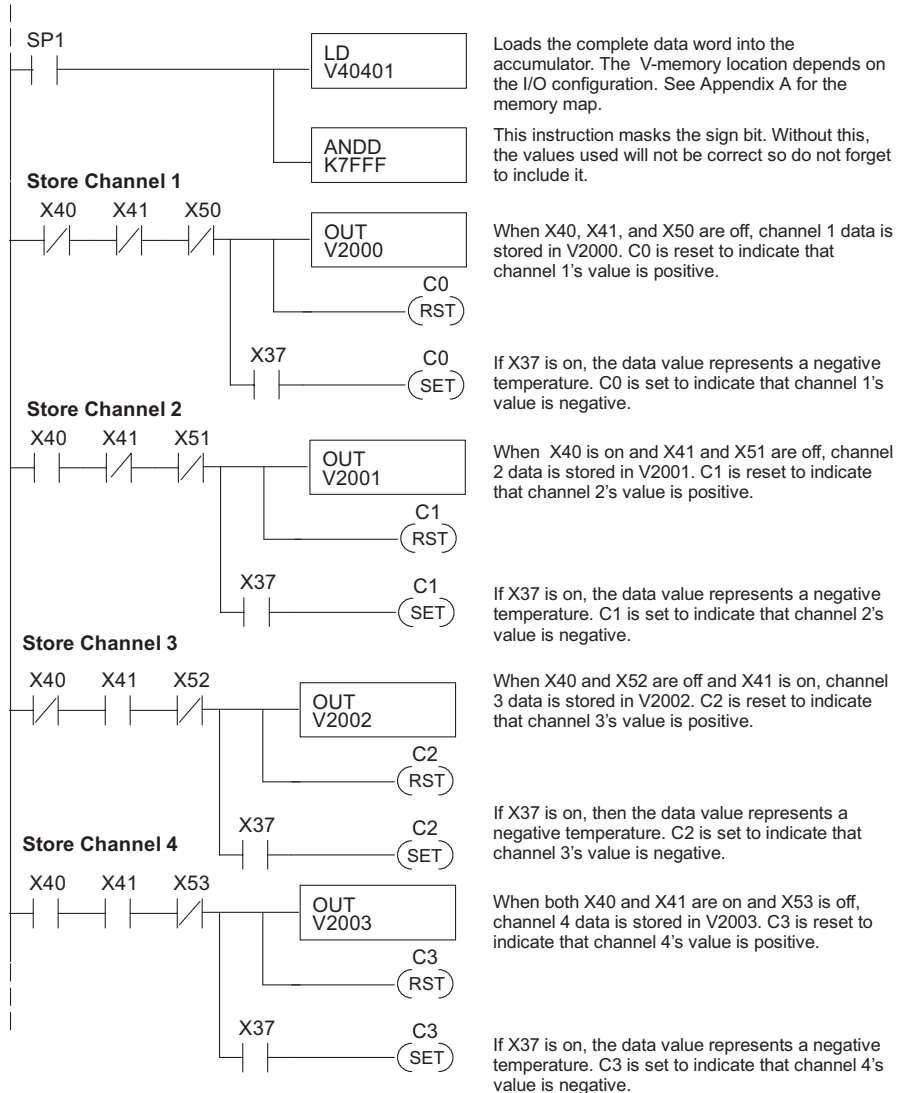

Reading 2's Compliment Values (Multiplexing)

The D2-230 CPU does not have the special V-memory locations that allows for automatic management of the data transfer. Since all channels are multiplexed into a single data word, the control program must be set up to determine which channel is being read. Since the module appears as X input points to the CPU, it is very easy to use the active channel status bits to determine which channel is being monitored. The 2's complement data format may be required to correctly display bipolar data on some operator interfaces. This data format could also be used to simplify averaging a bipolar signal. To view this data format in DirectSOFT, select Signed Decimal.

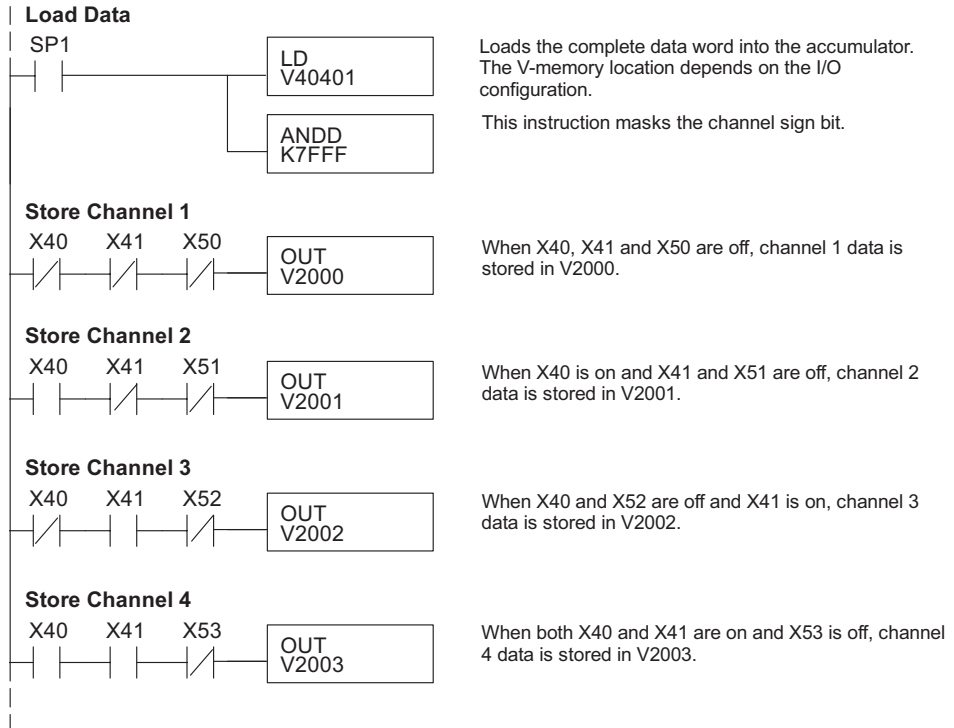

Scaling the Input Data

No scaling of the input temperature is required. The readings directly reflect the actual temperatures. For example: a reading of 8482 is 848.2°C, a reading of 16386 is -0.2°C (magnitude plus sign) and a reading of 32770 is -0.2°C (2's complement).

Module Resolution 16-Bit (Unipolar Voltage Input)

Unipolar analog signals are converted into 65536 counts ranging from 0–65535 (216). For example, with a 0–156mV signal range, 78mV would be 32767. A value of 65535 represents the upper limit of the range.

H or L = high or low limit of the range

$$\text{Unipolar Resolution} = \frac{H - L}{65535}$$

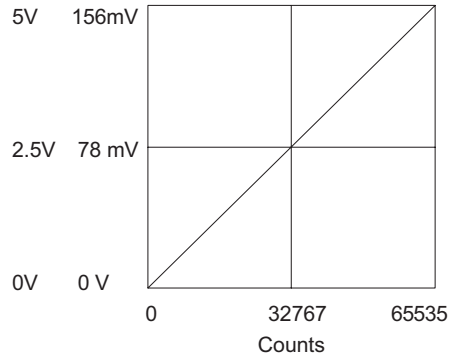

Module Resolution 15-Bit Plus Sign(Bipolar Voltage Input)

The module has 16-bit unipolar or 15-bit + sign bipolar resolution. Bipolar analog signals are converted into 32768 counts ranging from 0–32767 (215). For example, with a -156mV–156mV signal range, 156mV would be 32767. The bipolar ranges utilize a sign bit to provide 16-bit resolution. A value of 32767 can represent the upper limit of either side of the range. Use the sign bit to determine negative values.

H or L = high or low limit of the range

$$\text{Bipolar Resolution} = \frac{H - L}{32767}$$

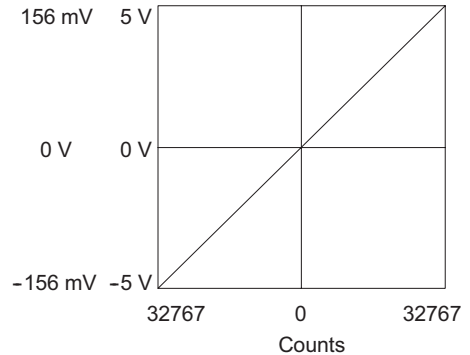

Analog and Digital Value Conversions

Sometimes it is useful to be able to quickly convert between the signal levels and the digital values. This is especially helpful during startup or troubleshooting. This module does not operate like other versions of analog input modules. The bipolar ranges use 0–32767 for both positive and negative voltages. The sign bit allows this and it actually provides better resolution than those modules that do not offer a sign bit. The following table provides formulas to make this conversion easier.

Range	If the digital value is known	If the analog signal level is known.
0–5 V	$A = \frac{5D}{65535}$	$D = \frac{65535}{5} (A)$
0–156.25 mV	$A = \frac{0.15625D}{65535}$	$D = \frac{65535}{0.15625} (A)$
±5V	$A = \frac{10D}{65535}$	$D = \frac{65535}{10} (A)$
±156.25 mV	$A = \frac{0.3125D}{65535}$	$D = \frac{65535}{0.3125} (A)$

For example, if the ±5V range is used and the signal is measured at 2.5V, use the following formula to determine the digital value that is stored in the V-memory location that contains the data.

$$D = \frac{65535}{10} (A)$$

$$D = \frac{65535}{10} (2.5V)$$

$$D = 6553.5 (2.5)$$

$$D = 16383.75$$

Filtering Input Noise (D2-250-1, D2-260 and D2-262 CPUs Only)

Add the following logic to filter and smooth analog input noise in D2-250-1, D2-260 and D2-262 CPUs. This is especially useful when using PID loops. Noise can be generated by the field device and/or induced by field wiring.

In the following example, the analog value in BCD is first converted to a binary number. Memory location V1400 is the designated workspace in this example. The MULR instruction is the filter factor, which can be from 0.1–0.9. The example uses 0.2. Using a smaller filter factor increases filtering. A higher precision value can be used, but it is not generally needed. The filtered value is then converted back to binary and then to BCD. The filtered value is stored in location V1402 for use in the application program or a PID loop.

NOTE: Please review intelligent instructions (IBox) in Chapter 5, which simplify this and other functions. The IBox instructions are supported by the D2-250-1, D2-260 and D2-262.



NOTE: Be careful not to do a multiple number conversion on a value. For example, if the pointer method is used to get the analog value, it is in BCD and must be converted to binary. However, if the conventional method of reading analog is used and the first 15 bits are masked, the value is already in binary and no conversion is needed. Also, if the conventional method is used, change the LDD V2000 instruction to LD V2000.

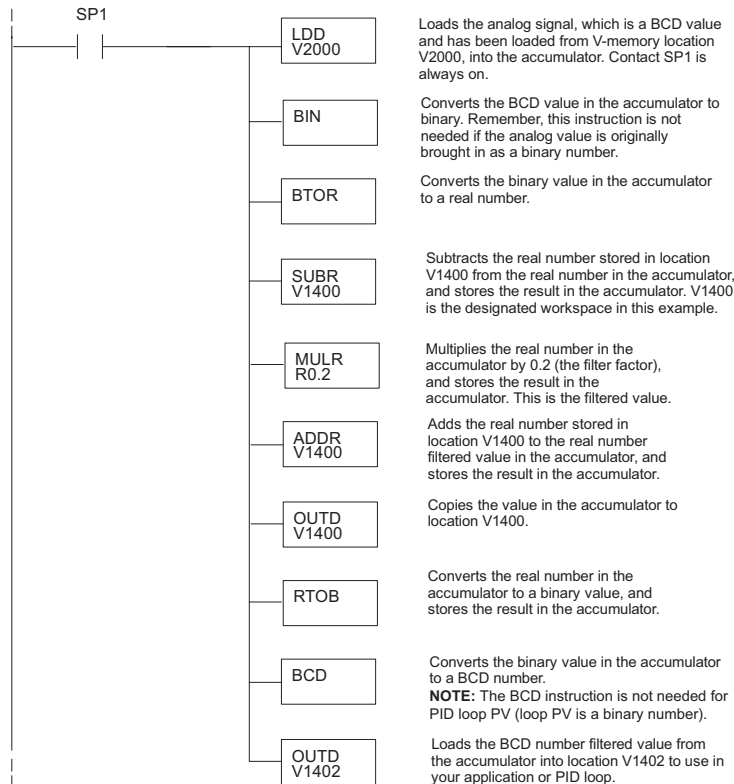

F2-02DA-1, F2-02DA-1L 2-CHANNEL ANALOG CURRENT OUTPUT



In This Chapter...

Module Specifications	8-2
Connecting and Disconnecting the Field Wiring	8-5
Module Operation	8-7
Writing the Control Program.....	8-11

Module Specifications

The F2-02DA-1 and F2-02DA-1L Analog Output modules provide several hardware features:

- Analog outputs are optically isolated from the PLC logic.
- The modules have a removable terminal block so the module can be easily removed or changed without disconnecting the wiring.
- Both channels can be updated in one scan when a D2-240, D2-250-1, D2-260 or D2-262 CPU is used in the DL205 PLC.
- F2-02DA-1: Low-power CMOS design requires less than 60mA from an external 24VDC power supply.
- F2-02DA-1L: Low-power CMOS design requires less than 70mA from an external 12VDC power supply.



NOTE: The F2-02DA-1 and F2-02DA-1L modules look very similar and it is very easy to mistake one module for the other. If the module being used does not work, check the terminal label to see if it is a 12V(L) or a 24V model and that it is being supplied with the proper input voltage.

Analog Output Configuration Requirements

The F2-02DA-1(L) Analog output module requires 16 discrete output points. The module can be installed in any slot when using a D2-240 (firmware V1.5 or later), D2-250-1, D2-260 or D2-262 CPUs. The available power budget and discrete I/O points are the limiting factors. Check the user manual for the particular model of CPU and I/O base being used for more information regarding power budget and number of local, local expansion or remote I/O points.

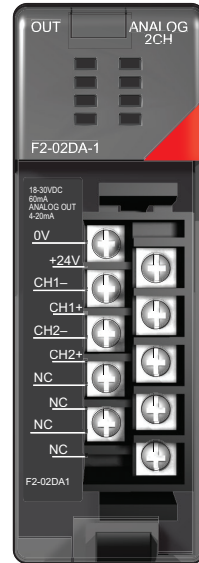

F2-02DA-1

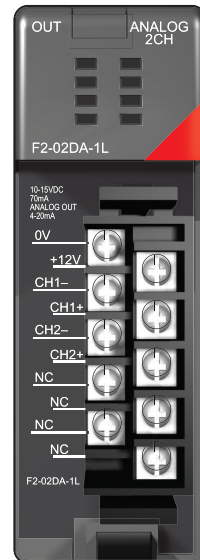

F2-02DA-1L

Chapter 8: F2-02DA-1, F2-02DA-1L, 2-Channel Analog Current Output

The following tables provide the specifications for the F2-02DA-1 and F2-02DA-1L Analog Output Modules. Review these specifications to make sure the module meets your application requirements.

Output Specifications	
Number of Channels	2
Output Range	4–20 mA
Resolution	12 bit (1 in 4096)
Output Type	Single ended, 1 common
Maximum Loop Supply	30VDC
Peak Output Voltage	40VDC (clamped by transient voltage suppressor)
Load Impedance	0 Ω minimum
Maximum Load / Power Supply	620 Ω / 18V, 910 Ω / 24V, 1200 Ω / 30V
Linearity Error (end to end)	± 1 count ($\pm 0.025\%$ of full scale) maximum
Conversion Settling Time	100 μ s maximum (full scale change)
Full-scale Calibration Error (offset error included)	± 5 counts maximum, 20mA @ 25°C (77°F)
Offset Calibration Error	± 3 counts maximum, 4mA @ 25°C (77°F)
Maximum Inaccuracy	0.1% @ 25°C (77°F) 0.3% @ 0–60°C (32–140°F)
Accuracy vs. Temperature	± 50 ppm /°C full scale calibration change; (including maximum offset change of 2 counts)

General Specifications	
PLC Update Rate	1 channel per scan maximum (D2-230 CPU) 2 channels per scan maximum (D2-240, D2-250-1, D2-260 and D2-262 CPUs)
Digital Outputs Output Points Required	12 binary data bits, 2 channel ID bits 16 (Y) output points required
Power Budget Requirement	40mA @ 5VDC (supplied by the base)
External Power Supply	F2-02DA-1: 12–30 VDC ($\pm 10\%$), 60mA F2-02DA-1L: 12VDC ($\pm 10\%$), 70mA (add 20mA for each current loop used)
Operating Temperature	0–60°C (32–140°F)
Storage Temperature	-20°C to 70°C (-4°F to 158°F)
Relative Humidity	5–95% (non-condensing)
Environmental air	No corrosive gases permitted
Vibration	MIL STD 810C 514.2
Shock	MIL STD 810C 516.2
Noise Immunity	NEMA ICS3-304

Special Placement Requirements (D2-230 and Remote I/O Bases)

It is important to examine the configuration if a D2-230 CPU is being used. As can be seen in the section on Writing the Control Program in this chapter, V-memory locations are used to hold the analog data that will be written to the output. If the module is placed in a slot so that the output points do not start on a V-memory boundary, the program instructions aren't able to access the data. This also applies when placing this module in a remote base using a D2-RSSS in the CPU slot.

Correct!

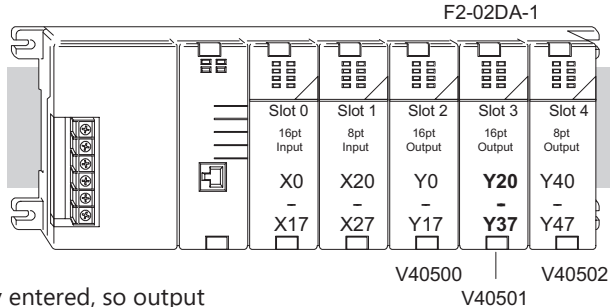

Data is correctly entered, so output points start on a V-memory boundary from the table below.

MSB										LSB									
Y										Y	Y								Y
3										3	2								2
7										7	0	7							0

Incorrect

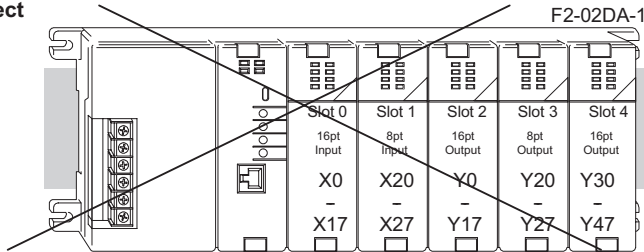

Data is split over three locations, so instructions cannot access data from a D2-230.

MSB										LSB									
Y										Y	Y								Y
5										5	4								4
7										7	0	7							0

To use the V-memory references required for a D2-230 CPU, the first output address assigned to the module must be one of the following Y locations. The table also shows the V-memory addresses that correspond to these Y locations.

X	Y0	Y20	Y40	Y60	Y100	Y120	Y140	Y160
V	V40500	V40501	V40502	V40503	V40504	V40505	V40506	V40507

Connecting and Disconnecting the Field Wiring

Wiring Guidelines

Your company may have guidelines for wiring and cable installation. If so, check the guidelines before beginning the installation. Here are some general things to consider:

- Use the shortest wiring route whenever possible.
- Use shielded wiring and ground the shield at the transmitter source. Do not ground the shield at both the module and the source.
- Do not run the signal wiring next to large motors, high current switches, or transformers. This may cause noise problems.
- Route the wiring through an approved cable housing to minimize the risk of accidental damage. Check local and national codes to choose the correct method for your application.

User Power Supply Requirements

The F2-02DA-1 (L) module requires at least one field-side power supply. The same or separate power sources can be used for the module supply and the current transmitter supply. The F2-02DA-1 module requires 18–30 VDC, at 60mA and the F2-02DA-1L module requires 12–15 VDC, at 70mA, from the external power supply.

The DL205 AC bases have a built-in 24VDC power supply that provide up to 300mA of current. This can be used instead of a separate supply. Check the power budget to be safe.

It is desirable in some situations to power the transmitters separately in a location remote from the PLC. This will work as long as the transmitter supply meets the voltage and current requirements, and the transmitter negative (-) side and the module power supply negative (-) side are connected together.



WARNING: If the internal 24VDC power budget is exceeded, it may cause unpredictable system operation that can lead to a risk of personal injury or equipment damage.

Wiring Diagram

The F2-02DA-1(L) module has a removable connector which helps to simplify wiring. Just squeeze the top and bottom retaining clips and gently pull the connector from the module. Use the following diagram to connect field wiring to a F2-02DA-1. Wiring for a F2-02DA-1L is similar except it uses a 12-15 VDC power source.

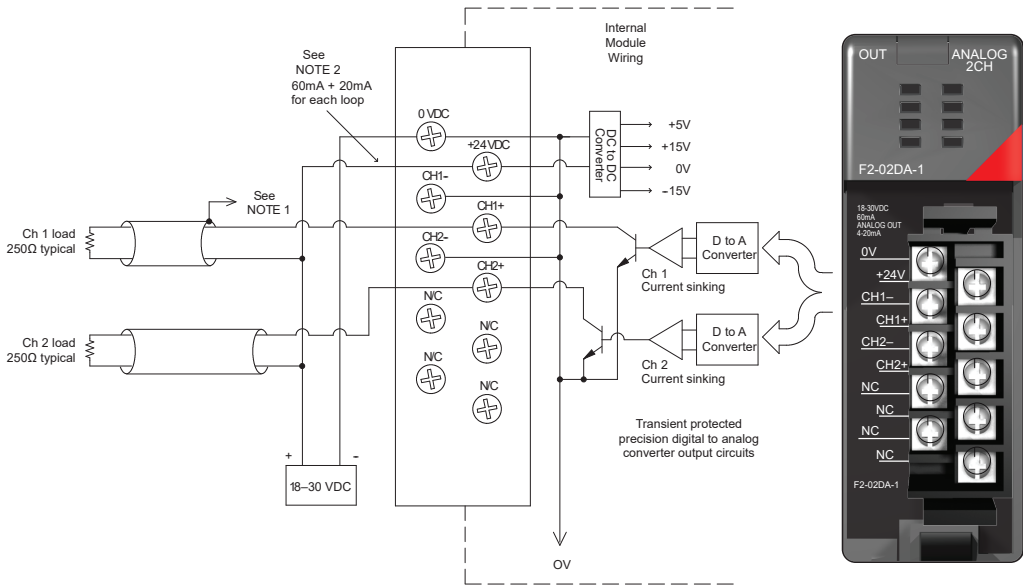

NOTE 1: Shields should be connected to the 0V terminal of the module or 0V of the power supply.

NOTE 2: This is 70mA + 20mA only for the F2-02DA-1L.

Load Range

The maximum load resistance depends on the particular loop power supply being used.

Loop Power Supply Voltage	Acceptable Load Range
30VDC	0-1200 Ω
24VDC	0-910 Ω
18VDC	0-620 Ω

Module Operation

Before beginning to write the control program, it is important to take a few minutes to understand how the module processes the analog signals.

Channel Scanning Sequence (Multiplexing) for a D2-230 CPU

The D2-230 can send one channel of data per CPU scan. The module refreshes two field devices on each scan, but new data can only be obtained from the CPU at the rate of one channel per scan. Since there are two channels, it can take two scans to update both channels. However, if only one channel is being used, then that channel will be updated on every scan. The multiplexing method can also be used for the D2-240, D2-250-1, D2-260 and D2-262 CPUs.

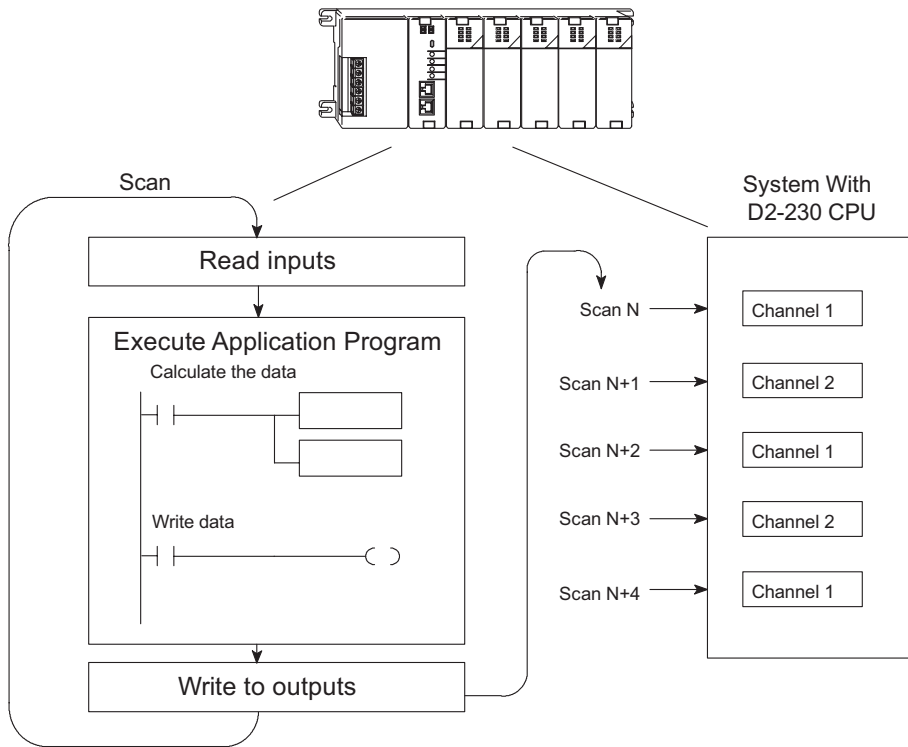

Channel Scanning Sequence (Pointer Method) for D2-240, D2-250-1, D2-260 and D2-262 CPUs

If either a D2-240, D2-250-1, D2-260 or D2-262 CPU is used, both channels can be updated on every scan. This is because the all three CPUs support special V-memory locations that are used to manage the data transfer. This is discussed in more detail in the next section in this chapter on Writing the Control Program.

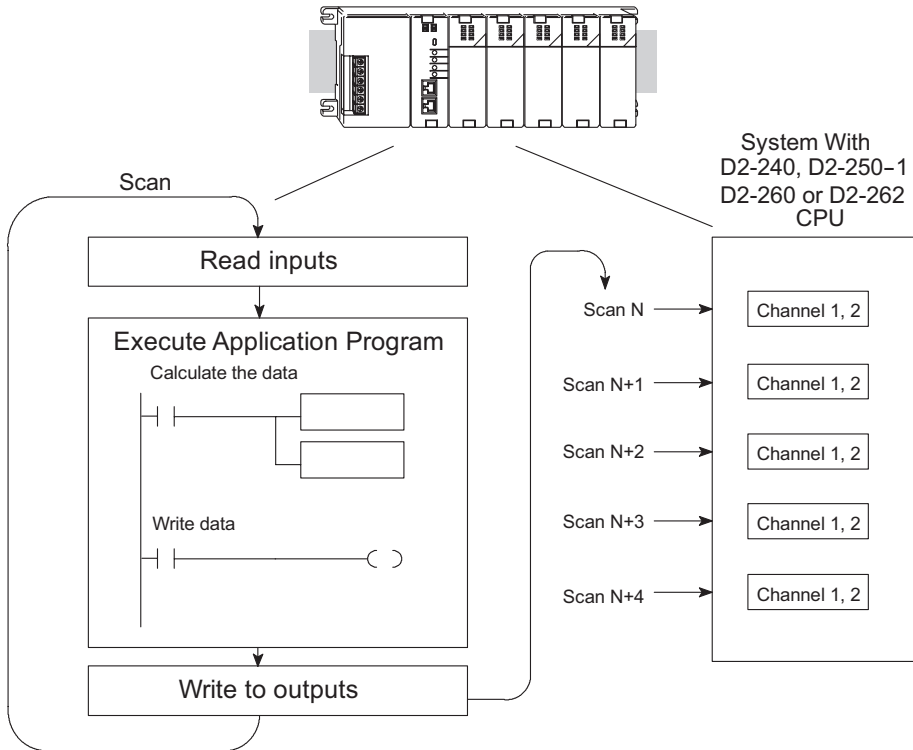

Understanding the Output Assignments

Remember that the F2-02DA-1 (L) module appears to the CPU as a 16-point discrete output module. These points provide the data value and an indication of which channel to update. Note, if either a D2-240, D2-250-1, D2-260 or a D2-262 CPU is being used, these bits may never have to be used, but it may be an aid to help understand the data format.

Since all output points are automatically mapped into V-memory, the location of the data word that will be assigned to the module can be simply determined.

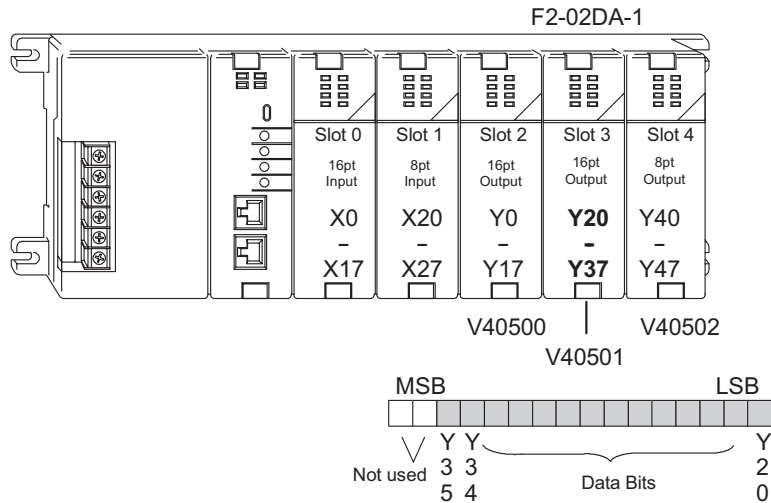

The individual bits in this data word location, represents specific information about the analog signal.

Channel Select Outputs

Two of the outputs select the active channel. Remember, the V-memory bits are mapped directly to discrete outputs. Turning a bit OFF selects its channel. By controlling these outputs, the channel(s) to be updated can be selected.

Y35	Y34	Channel
On	Off	1
Off	On	2
Off	Off	1 & 2 (same data to both channels)
On	On	None (both channels hold current values)

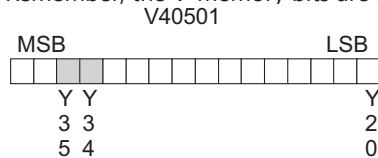

■ = channel select outputs

Analog Data Bits

The first twelve bits represent the analog data in binary format.

Bit	Value	Bit	Value
0	1	6	64
1	2	7	128
2	4	8	256
3	8	9	512
4	16	10	1024
5	32	11	2048

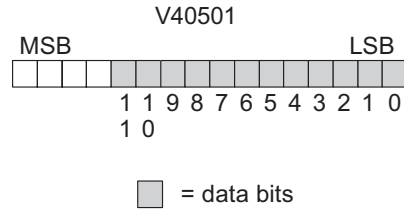

Module Resolution

Since the module has 12-bit resolution, the analog signal is converted into 4096 counts ranging from 0–4095 (2¹²). For example, send a 0 to get a 4mA signal and 4095 to get a 20mA signal. This is equivalent to a binary value of 0000 0000 0000 to 1111 1111 1111, or 000 to FFF hexadecimal. The diagram shows how this relates to the signal range. Each count can also be expressed in terms of the signal level by using the equation shown.

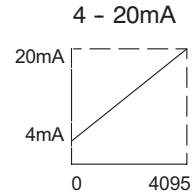

$$\text{Resolution} = \frac{H - L}{4095}$$

H = high limit of the signal range

L = low limit of the signal range

$$16\text{mA} / 4095 = 3.907\mu\text{A per count}$$

Writing the Control Program

Writing Values: Pointer Method and Multiplexing

There are two methods which can be used to write values from the CPU to the module:

- The pointer method
- Multiplexing

The multiplexing method must be used when using a D2-230 CPU. The multiplexing method must also be used with remote I/O modules (the pointer method will not work). Either method can be used with the D2-240, D2-250-1, D2-260 and D2-262 CPUs, however, the pointer method will simplify programming the PLC.

Pointer Method for the D2-240, D2-250-1, D2-260 and D2-262 CPUs

The D2-240, D2-250-1, D2-260 and D2-262 CPUs have special V-memory locations assigned to each base slot that will greatly simplify the programming requirements. These V-memory locations allow you to:

- Specify the data format
- Specify the number of channels to scan
- Specify the location of the data that will be written to the module



NOTE: D2-240 CPUs with firmware release version 1.5 or later and D2-250 CPUs with firmware release version 1.06 or later support this method.

The following example program shows how to setup these locations. Place this rung anywhere in the ladder program, or in the initial stage if stage programming instructions are being used. V2000 is used in the example but any user V-memory location can be used. In this example the module is installed in slot 3. Be sure to use the V-memory locations for the module placement. The pointer method automatically converts values to RCD.

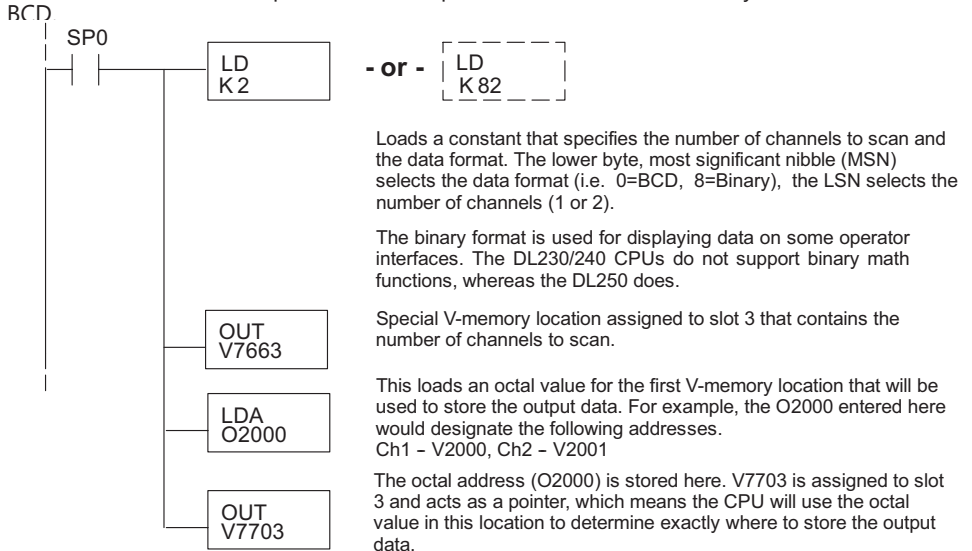

The following tables show the special V-memory locations used by the D2-240, D2-250-1, D2-260 and D2-262 for the CPU base and local expansion base I/O slots. Slot 0 (zero) is the module next to the CPU or D2-CM module. Slot 1 is the module two places from the CPU or D2-CM, and so on. Remember, the CPU only examines the pointer values at these locations after a mode transition. Also, if the D2-230 (multiplexing) method is used, verify that these addresses in the CPU are 0 (zero).

The table below applies to the D2-240, D2-250-1, D2-260 and D2-262 CPU base.

CPU Base: Analog Input Module Slot-Dependent V-memory Locations								
Slot	0	1	2	3	4	5	6	7
No. of Channels	V7660	V7661	V7662	V7663	V7664	V7665	V7666	V7667
Storage Pointer	V7700	V7701	V7702	V7703	V7704	V7705	V7706	V7707

The table below applies to the D2-250-1, D2-260 or D2-262 CPU base 1.

Expansion Base D2-CM #1: Analog Input Module Slot-Dependent V-memory Locations								
Slot	0	1	2	3	4	5	6	7
No. of Channels	V36000	V36001	V36002	V36003	V36004	V36005	V36006	V36007
Storage Pointer	V36020	V36021	V36022	V36023	V36024	V36025	V36026	V36027

The table below applies to the D2-250-1, D2-260 or D2-262 CPU base 2.

Expansion Base D2-CM #2: Analog Input Module Slot-Dependent V-memory Locations								
Slot	0	1	2	3	4	5	6	7
No. of Channels	V36100	V36101	V36102	V36103	V36104	V36105	V36106	V36107
Storage Pointer	V36120	V36121	V36122	V36123	V36124	V36125	V36126	V36127

The table below applies to the D2-260 and D2-262 CPU base 3.

Expansion Base D2-CM #3: Analog Input Module Slot-Dependent V-memory Locations								
Slot	0	1	2	3	4	5	6	7
No. of Channels	V36200	V36201	V36202	V36203	V36204	V36205	V36206	V36207
Storage Pointer	V36220	V36221	V36222	V36223	V36224	V36225	V36226	V36227

The table below applies to the D2-260 and D2-262 CPU base 4.

Expansion Base D2-CM #4: Analog Input Module Slot-Dependent V-memory Locations								
Slot	0	1	2	3	4	5	6	7
No. of Channels	V36300	V36301	V36302	V36303	V36304	V36305	V36306	V36307
Storage Pointer	V36320	V36321	V36322	V36323	V36324	V36325	V36326	V36327

Writing Data (Multiplexing)

The D2-230 CPU does not have the special V-memory locations that allows for automatic management of data transfer. Since all channels are multiplexed into a single data word, the control program must be written in such a way to determine which channel to write the data to. Since the module appears as Y output points to the CPU, it is very easy to use the channel selection outputs to determine which channel to update.

The following example is for a module installed as shown in the previous examples. The addresses used would be different if the module were located in a different slot. These rungs can be placed anywhere in the user program or, if using stage programming, placed in an active stage. This example is a two-channel multiplexer that updates each channel on alternate scans. Relay SP7 is a special relay that is on for one scan, then off for one scan.

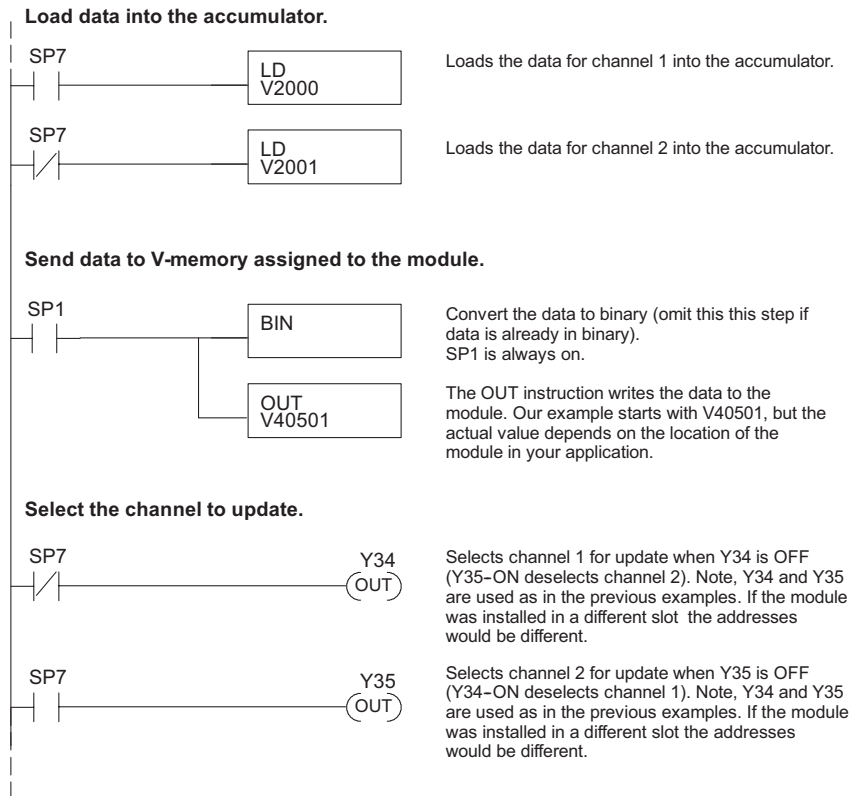

NOTE: Use binary data to write to the module outputs. Do not use a BIN instruction if the data is already in binary format.

Write Data to One Channel

The following example can be used if only one channel is to be written to, or if the outputs are to be controlled individually. In this example data is written to output channel 1.

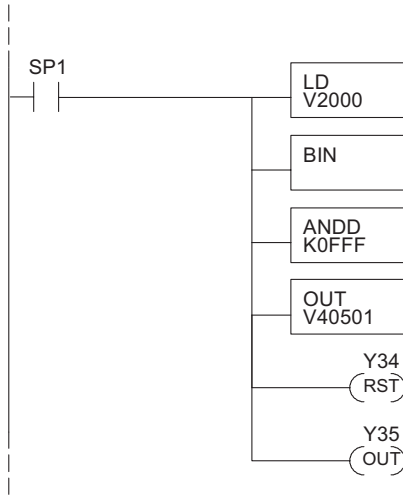

The LD instruction loads the data into the accumulator. Since SP1 is used, this rung automatically executes on every scan. Permissive contacts X, C, etc. could also be used.

The BIN instruction converts the accumulator data to binary (omit this step a if is already in binary format).

This AND Double instruction logically ANDs the accumulator with the constant FFF. It keeps the data from affecting channel select bits.

The OUT instruction writes the data to the module output. This example starts with V40501, but the actual value depends on the location of the module in your application.

Y34-OFF selects channel 1 for updating.

Y35-ON deselected channel 2 (do not update).

Write Data to Both Channels

In the example below, if both selected channels are off, they will be updated with the same data.

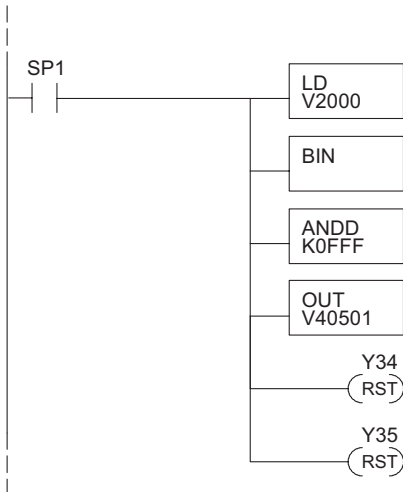

The LD instruction loads the data into the accumulator. Since SP1 is used, this rung automatically executes on every scan. Permissive contacts X, C, etc. could also be used.

The BIN instruction converts the accumulator data to binary (omit this step a if is already in binary format).

This AND Double instruction logically ANDs the accumulator with the constant FFF. It keeps the data from affecting channel select bits.

The OUT instruction writes the data to the module output. This example starts with V40501, but the actual value depends on the location of the module in your application.

Y34-OFF selects channel 1 for updating.

Y35-OFF selects channel 2 for updating.

Calculating the Digital Value

The control program must calculate the digital value that is sent to the analog output. Several methods can be used to do this, but the best method is to convert the values to engineering units. This is accomplished by using the formula shown.

Adjustments may have to be made to the formula depending on the scale of the engineering units.

Consider the following example which controls pressure from 0.0 – 99.9 PSI. To calculate the digital value, use the formula. The result will be sent to the analog output. The example shows the conversion required to yield 49.4 PSI. The multiplier of 10 is used because the decimal portion of 49.4 cannot be loaded in the program, so it is shifted right one decimal place to make a usable value of 494.

$$A = U \frac{4095}{H - L}$$

A = Analog Value (0 – 4095)

U = Engineering Units

H = High limit of the engineering unit range

L = Low limit of the engineering unit range

$$A = 10U \frac{4095}{10(H - L)}$$

$$A = 494 \frac{4095}{1000 - 0}$$

$$A = 2023$$

Analog and Digital Value Conversions

It is sometimes useful to do quick conversions between the signal levels and the digital values. This can be helpful during startup or troubleshooting. The following table shows some formulas to help with the conversions.

Range	If the digital value is known	If the analog signal level is known.
4–20 mA	$A = \frac{16D}{4095} + 4$	$D = \frac{4095}{16} (A - 4)$

For example, to convert a 10mA signal level to a digital value, in the above equation substitute 10 for A and complete the math as shown in the example to the right.

$$D = \frac{4095}{16} (A - 4)$$

$$D = \frac{4095}{16} (10\text{mA} - 4)$$

$$D = (255.93) (6)$$

$$D = 1536$$

The Conversion Program

The example program shows how to write the program to perform the engineering unit conversion. This example assumes that a BCD value has been stored in V2300 and V2301 for channels 1 and 2 respectively.



NOTE: The DL205 has many instructions available so that math operations can be performed simply using BCD format. Do the math in BCD, then convert to binary before writing to the module output.

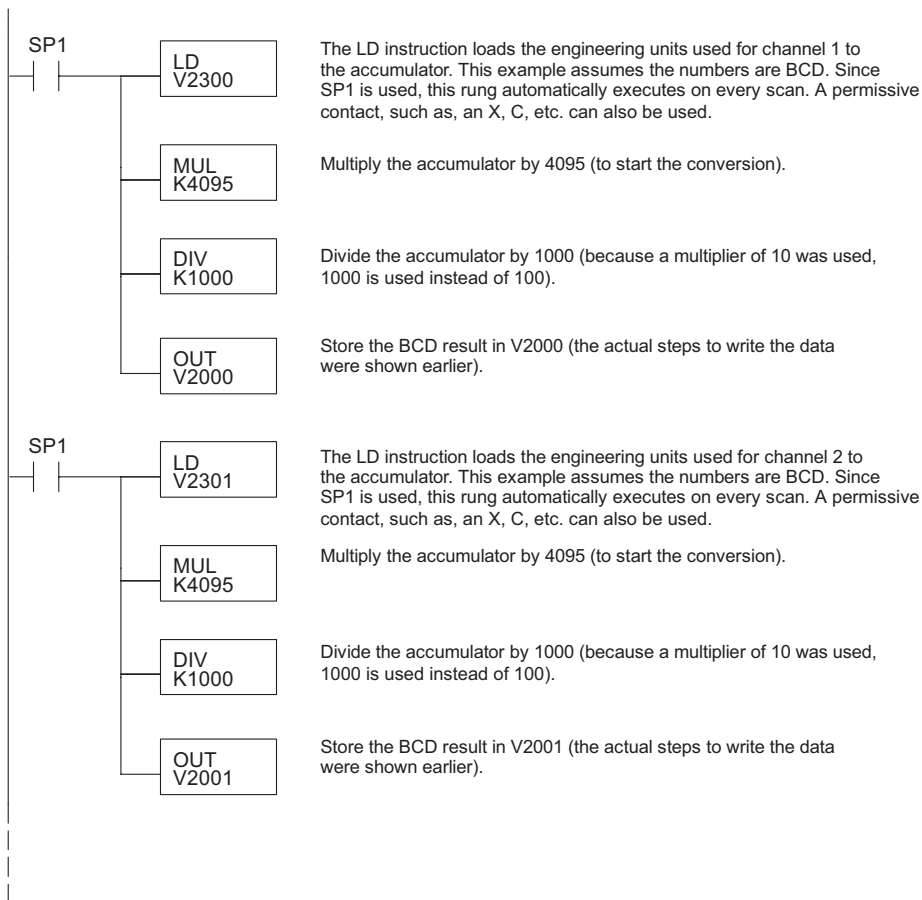

F2-02DA-2, F2-02DA-2L* 2-CHANNEL ANALOG VOLTAGE OUTPUT



CHAPTER 9

In This Chapter...

Module Specifications	9-2
Setting the Module Jumpers	9-5
Connecting and Disconnecting the Field Wiring	9-8
Module Operation	9-10
Writing the Control Program.....	9-15



***NOTE:** *The F2-02DA-2L module has been discontinued. Please consider F2-02DA-2 as a replacement.*

Module Specifications

The F2-02DA-2 and *F2-02DA-2L Analog Output modules provide several hardware features:

- Analog outputs are optically isolated from the PLC logic.
- The modules have a removable terminal block so the module can be easily removed or changed without disconnecting the wiring.
- Both channels can be updated in one scan if either a D2-240, a D2-250-1, a D2-260 or a D2-262 CPU is used in the PLC.
- F2-02DA-2: Low-power CMOS design requires less than 60mA from an external 24VDC power supply.
- *F2-02DA-2L: Low-power CMOS design requires less than 70mA from an external 12VDC power supply.
- Outputs can be independently configured for any of the following ranges:
 1. 0–5 VDC
 2. 0–10 VDC
 3. ±5VDC
 4. ±10VDC

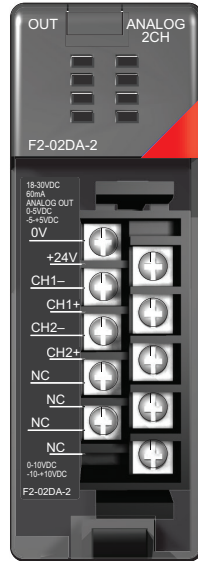

F2-02DA-2

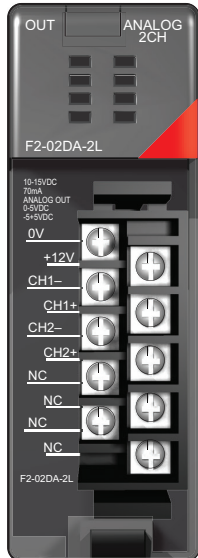

*F2-02DA-2L

NOTE: The F2-02DA-2 and F2-02DA-2L modules look very similar and it is very easy to mistake one module for the other. If the module being used does not work, check the terminal label to see if it is a 12V (L) or a 24V model and that it is being supplied with the proper input voltage.

Analog Output Configuration Requirements

The F2-02DA-2(L) analog output module requires 16 discrete output points. The module can be installed in any slot of a DL205 PLC, but the available power budget and discrete I/O points are the limiting factors. Check the DL205 PLC User Manual for the particular model of CPU and I/O base being used for information regarding power budget and number of local, local expansion or remote I/O points.

***NOTE:** The F2-02DA-2L module has been discontinued. Please consider F2-02DA-2 as a replacement.

Chapter 9: F2-02DA-2, F2-02DA-2L, 2-Channel Analog Voltage Output

The following tables provide the specifications for the F2-02DA-2 and *F2-02DA-2L Analog Output Modules.

Output Specifications	
Number of Channels	2
Output Range	0–5V, 0–10V, $\pm 5V$, $\pm 10V$
Resolution	12 bit (1 in 4096)
Output Type	Single ended, 1 common
Peak Output Voltage	15VDC (clamped by transient voltage suppressor)
Load Impedance	2000 Ω minimum
Load Capacitance	0.01 μF maximum
Linearity Error (end to end)	± 1 count ($\pm 0.025\%$ of full scale) maximum
Conversion Settling Time	5 μs maximum (full scale change)
Full-scale Calibration Error (offset error included)	± 12 counts maximum, @ 25°C (77°F) unipolar ± 16 counts maximum, @ 25°C (77°F) bipolar
Offset Calibration Error	± 3 counts maximum, @ 25°C (77°F) unipolar ± 8 counts maximum, @ 25°C (77°F) bipolar
Maximum Inaccuracy	Unipolar ranges $\pm 0.3\%$ @ 25°C (77°F) $\pm 0.45\%$ 0–60°C (32–140°F) Bipolar ranges $\pm 0.4\%$ @ 25°C (77°F) $\pm 0.55\%$ 0–60°C (32–140°F)
Accuracy vs. Temperature	± 50 ppm/°C full scale calibration change; (including maximum offset change of 2 counts)

General Specifications	
PLC Update Rate	1 channel per scan maximum (D2-230 CPU) 2 channels per scan maximum (D2-240, D2-250-1, D2-260 and D2-262 CPUs)
Digital Outputs Output Points Required	12 binary data bits, 2 channel ID bits, 1 sign bit 16 point (Y) output module
Power Budget Requirement	40mA @ 5VDC (supplied by the base)
External Power Supply	F2-02DA-2: 24–30 VDC ($\pm 10\%$), 60mA (outputs fully loaded) F2-02DA-2L: 12VDC ($\pm 10\%$), 70mA (outputs fully loaded)
Operating Temperature	0–60°C (32–140°F)
Storage Temperature	–20°C to 70°C (–4°F to 158°F)
Relative Humidity	5–95% (non-condensing)
Environmental Air	No corrosive gases permitted
Vibration	MIL STD 810C 514.2
Shock	MIL STD 810C 516.2
Noise Immunity	NEMA ICS3-304



***NOTE:** The F2-02DA-2L module has been discontinued. Please consider F2-02DA-2 as a replacement.

Special Placement Requirements (D2-230 and Remote I/O Bases)

It is important to examine the configuration if a D2-230 CPU is being used. As can be seen in the section on Writing the Control Program, V-memory locations are used to hold the analog data that will be written to the output. If the module is placed in a slot such that the output points do not start on a V-memory boundary, the program instructions aren't able to access the data. This also applies when placing this module in a remote base using a D2-RSSS in the CPU slot.

Correct!

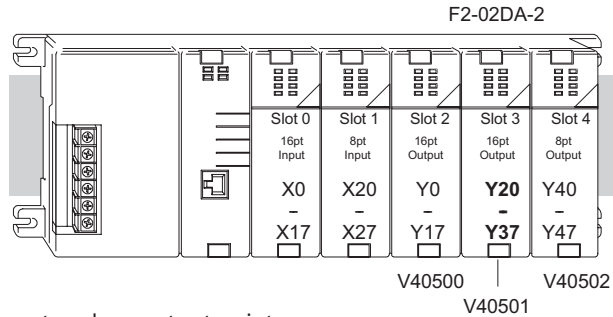

Data is correctly entered, so output points start on a V-memory boundary.

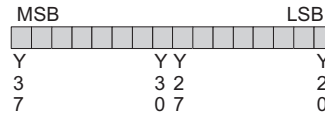

Incorrect

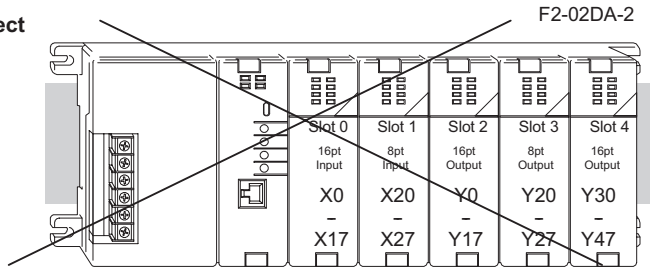

Data is split over three locations, so instructions cannot access data from a D2-230.

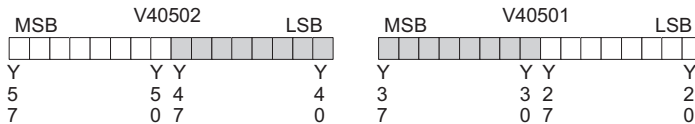

To use the V-memory references required for a D2-230 CPU, the first output address assigned to the module must be one of the following Y locations. The table also shows the V-memory addresses corresponding to these Y locations.

X	Y0	Y20	Y40	Y60	Y100	Y120	Y140	Y160
V	V40500	V40501	V40502	V40503	V40504	V40505	V40506	V40507

Setting the Module Jumpers

The F2-02DA-2 (L) Analog Output module uses jumpers for selecting the voltage ranges for each channel. The range of each channel can be independently set. Available operating ranges are 0–5 V, 0–10 V, ± 5 V, and ± 10 V.

There are three jumpers for each channel. Two sets are on the top board, and the third set is along the edge of the bottom board with the black D-shell backplane connector. Install or remove these jumpers to select the desired range. Unused jumpers can be stored on a single pin so they do not get lost.

- Two of the top board jumpers are labeled “UNI / ± 5 ” and there is one for each channel.
- The two bottom board jumpers are labeled “UNI” and there is one for each channel. These jumpers determine the format of the channel output data, and the effect of their settings is independent from that of the other jumpers on the module. With a UNI jumper removed, the corresponding channel requires data values in the range of ± 2047 . With a UNI jumper installed, the channel requires data values in the range of 0–4095.
- The other two top board jumpers are labeled “BI-P0-5” and there is one for each channel. These jumpers each have three possible settings (including jumper removed) since there are three pins.



NOTE: It is important to set the module jumpers correctly. The module will not operate correctly if the jumpers are not properly set for the desired voltage range.

This figure shows the jumper locations. See the table on the following page to determine the proper settings for your application.

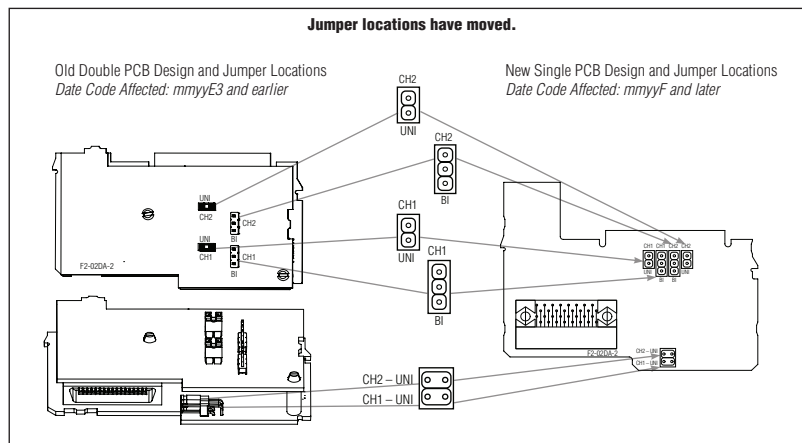

Voltage Range and Output Combinations

The table lists the eight possible combinations of voltage ranges and data formats, along with the corresponding jumper settings. For most applications, use one of the four standard selections (indicated by an asterisk) in the table below. Standard unipolar voltage ranges accept a data format of 0–4095. Standard bipolar ranges accept a data format of -2047 to +2047.

Voltage Range and Output Combinations					
Voltage Range	Output Data Format	UNI / $\pm 5V$ Jumper Settings (top board)	UNI Output Format Jumper Settings (bottom board)	BI-P 0–5 V Jumper Settings (top board)	
				BI-P (Bipolar) Position	0–5 V Position
0–5 V *	0–4095 *	Install	Install		Install here
0–10 V *	0–4095 *	Install	Install	Completely remove	
0–5 V	± 2047	Install	Remove		Install here
0–10 V	± 2047	Install	Remove	Completely remove	
$\pm 5V$ *	± 2047 *	Install	Remove	Install here	
$\pm 10V$ *	± 2047 *	Remove	Remove	Install here	
$\pm 5V$	0–4095	Install	Install	Install here	
$\pm 10V$	0–4095	Remove	Install	Install here	

Standard selections are shown with an *.

For example, to select settings of “ $\pm 5V$ ” voltage range with a “ ± 2047 ” output data format for channel 1, refer to the table above and the figure on the previous page and arrange the jumpers as follows:

- Install the “CH1 UNI / $\pm 5V$ ” jumper.
- Remove the “CH1-UNI” jumper. Store the jumper so it does not get lost by placing it on one pin.
- Install the “CH1” “BI-P0-5” jumper in the BI-P (bipolar) position on the left pin and center pin.

The non-standard selections in the table provide the opposite data format for both unipolar and bipolar voltage ranges. If you are using unipolar output (0-5 V or 0-10 V) on one channel and bipolar output ($\pm 5V$, $\pm 10V$) on the other channel, then one of the outputs will use a non-standard data format.

The following graphs show the voltage range to output data format relationship for each of the eight selections.

Unipolar Ranges

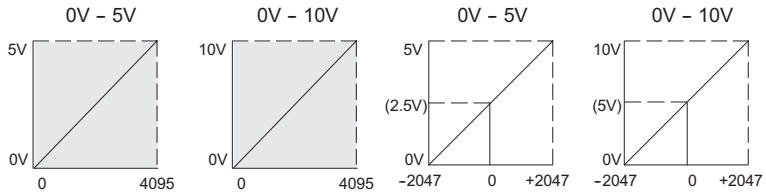

Bipolar Ranges

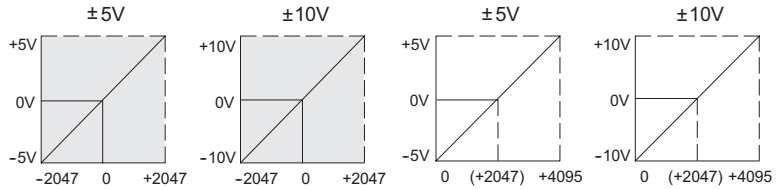

Connecting and Disconnecting the Field Wiring

Wiring Guidelines

Your company may have guidelines for wiring and cable installation. If so, check the guidelines before beginning the installation. Here are some general things to consider:

- Use the shortest wiring route whenever possible.
- Use shielded wiring and ground the shield at the transmitter source. Do not ground the shield at both the module and the source.
- Do not run the signal wiring next to large motors, high current switches, or transformers. This may cause noise problems.
- Route the wiring through an approved cable housing to minimize the risk of accidental damage. Check local and national codes to choose the correct method for your application.

User Power Supply Requirements

The F2-02DA-2 (L) module requires at least one field-side power supply. The same or separate power sources can be used for the module supply and the voltage transmitter supply. The F2-02DA-2 module requires 18–30 VDC, at 60mA and the *F2-02DA-2L module requires 10–15 VDC, at 70mA, from the external power supply.

The DL205 AC bases have a built-in 24VDC power supply that provide up to 300mA of current. This can be used instead of a separate supply. Check the power budget to be safe.

It is desirable in some situations to power the transmitters separately in a location remote from the PLC. This will work as long as the transmitter supply meets the voltage and current requirements, and the transmitter negative (-) side and the module supply negative (-) side are connected together..



WARNING: If the internal 24VDC base power is used, be sure to calculate the power budget. Exceeding the power budget can cause unpredictable system operation that can lead to a risk of personal injury or equipment damage.



***NOTE:** *The F2-02DA-2L module has been discontinued. Please consider F2-02DA-2 as a replacement.*

Wiring Diagram

The F2-02DA-2(L) module has a removable connector which helps to simplify wiring. Just squeeze the top and bottom retaining clips and gently pull the connector from the module. Use the following diagram to connect the field wiring.

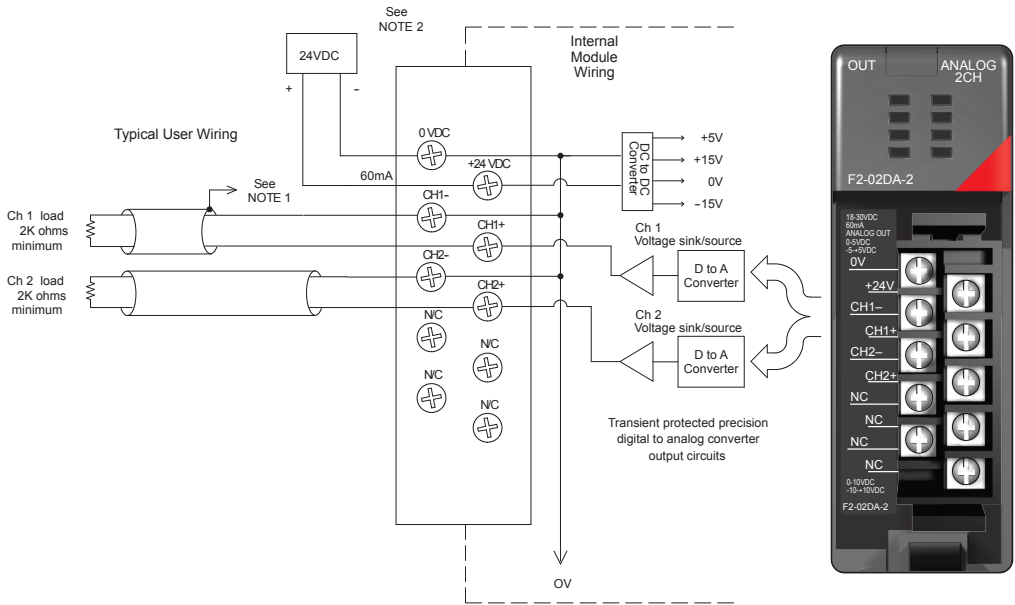

NOTE 1: Shields should be connected to the 0V terminal of the module or 0V of the power supply.

NOTE 2: The F2-02DA-2L module must use a 12VDC, at 70mA, external power supply.

NOTE 3: Unused voltage outputs should remain open (no connections) for minimum power consumption.

Module Operation

Before beginning to write the control program, it is important to take a few minutes to understand how the module processes the analog signals.

Channel Scanning Sequence (Multiplexing) for a D2-230 CPU

The D2-230 can send one channel of data per CPU scan. The module refreshes two field devices on each scan, but new data can only be obtained from the CPU at the rate of one channel per scan. Since there are two channels, it can take two scans to update both channels. However, if only one channel is being used, then that channel will be updated on every scan. The multiplexing method can also be used for the D2-240, D2-250-1, D2-260 and D2-262 CPUs.

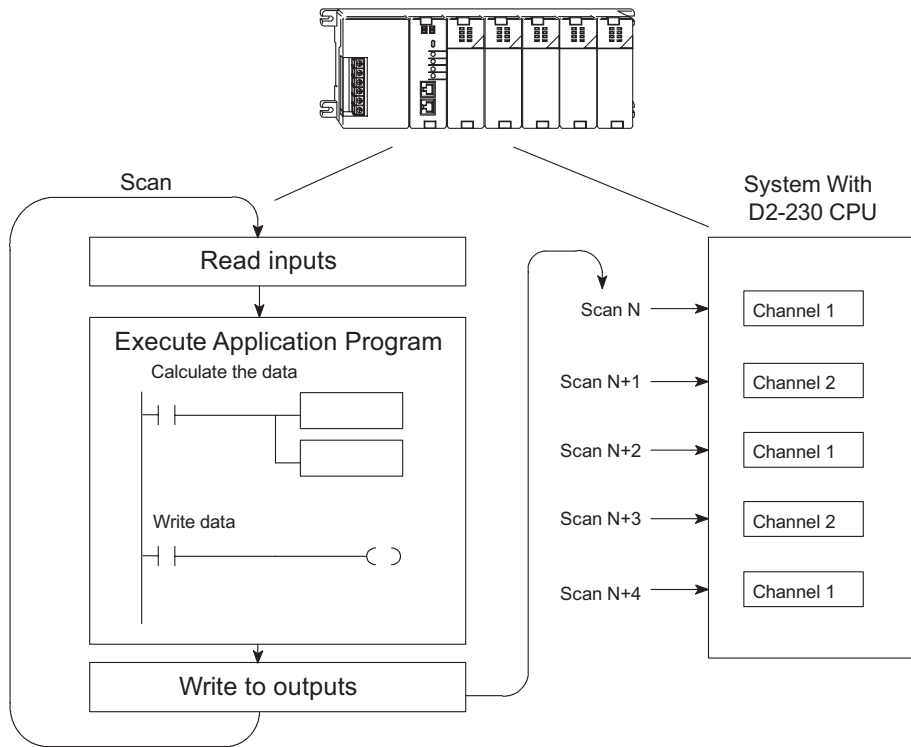

Channel Scanning Sequence (Pointer Method) for D2-240, D2-250-1, D2-260 and D2-262 CPUs

If either a D2-240, D2-250-1, D2-260 or D2-262 CPU is used, both channels can be updated on every scan. These CPUs support special V-memory locations that are used to manage the data transfer. This is discussed in more detail in the section Writing the Control Program later in this chapter.

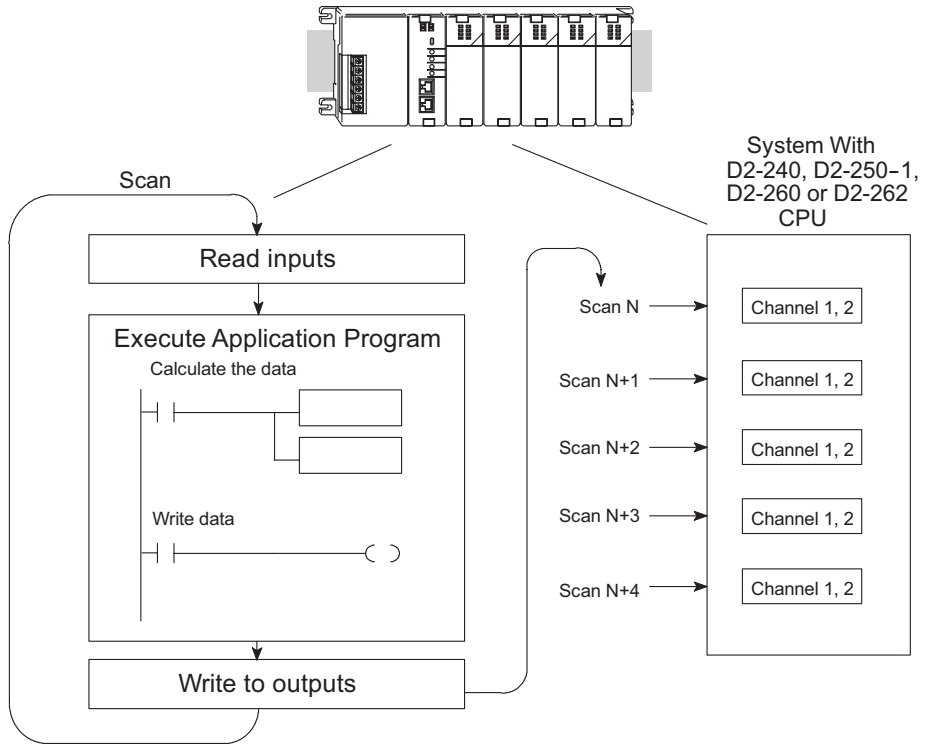

Understanding the Output Assignments

Remember that the F2-02DA-2 (L) module appears to the CPU as a 16-point discrete output module. These points provide the data value and an indication of which channel to update. Note, if either a D2-240, DL250-1, D2-260 or D2-262 CPU is being used, these bits may never have to be used, but it may be an aid to help understand the data format.

Since all output points are automatically mapped into V-memory, the location of the data word that will be assigned to the module can be simply determined.

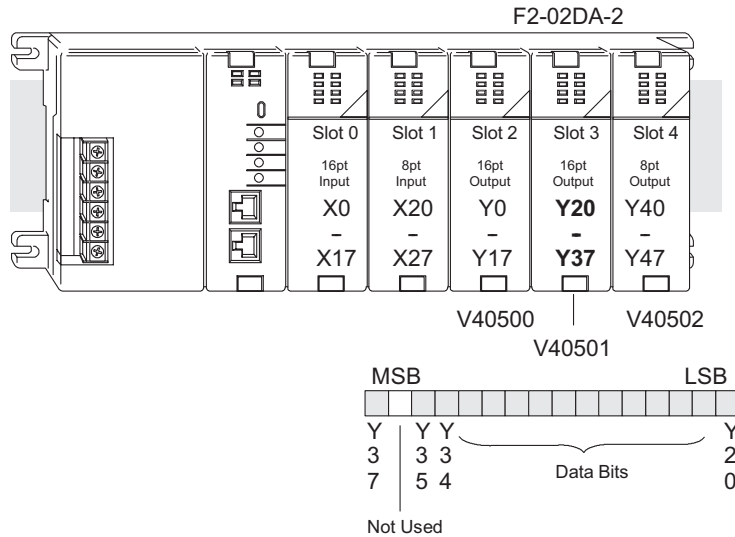

The individual bits in this data word location, represents specific information about the analog signal.

Channel Select Outputs

Two of the outputs select the active channel. Remember, the V-memory bits are mapped directly to discrete outputs. Turning a bit OFF selects its channel. By controlling these outputs, the channel(s) to be updated can be selected.

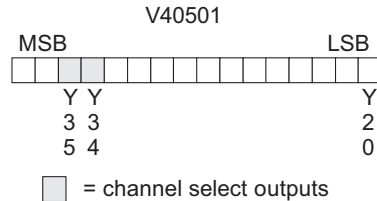

Y35	Y34	Channel
On	Off	1
Off	On	2
Off	Off	1 & 2 (same data to both channels)
On	On	None (both channels hold current values)

Analog Data Bits

The first twelve bits represent the analog data in binary format.

Bit	Value	Bit	Value
0	1	6	64
1	2	7	128
2	4	8	256
3	8	9	512
4	16	10	1024
5	32	11	2048

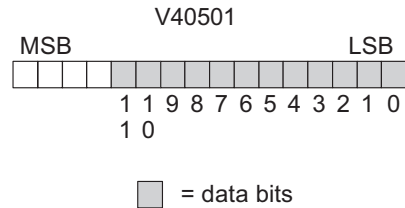

Signal Sign Output

The last output can be used to select the signal sign (+ or -) for bipolar ranges. By controlling this output, positive and negative data values can be easily selected.

Programming examples in the next section, Writing the Control Program, will show how to make sign selection part of the program.

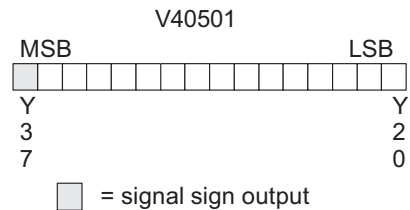

Bipolar Output Data

If an output channel is configured for an output format of 0–2047, the maximum valid value for the lower 12 bits is 2047. This means that bit 11 (bit position 12) must always be 0 (zero).

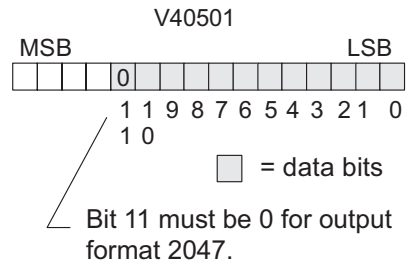

WARNING: If the data value exceeds 2047, bit 11 becomes a "1", and the other eleven bits start over at "000000000000". At this point the module's channel output voltage also goes back to the bottom of its range and begins to increase again. The RLL program will be expecting a maximum output, but it will be minimum instead. This can have serious consequences in some applications, and may result in personal injury or damage to equipment. Therefore, in standard bipolar ranges (or whenever the output format is ± 2047 in general), be sure that the RLL program does not create numbers with absolute values greater than 2047.

Module Resolution

Since the module has 12-bit resolution, the analog signal is converted into 4096 counts ranging from 0–4095 (212). For example, with a 0–10 V range, send a 0 to get a 0V signal, and send 4095 to get a 10V signal. This is equivalent to a binary value of 0000 0000 0000 to 1111 1111 1111, or 000 to FFF hexadecimal.

Each count can also be expressed in terms of the signal level by using the following equation.

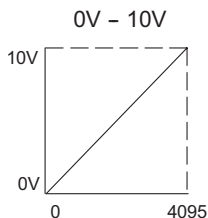

$$\text{Resolution} = \frac{H - L}{4095}$$

H = High limit of the signal range

L = Low limit of the signal range

Voltage Range	Signal Span	Divide By	Smallest Output Change
0–5 V	5V	4095	1.22 mV
0–10 V	10V	4095	2.44 mV
± 5V	10V	4095	2.44 mV
± 10V	20V	4095	4.88 mV

The following table shows the smallest change in signal level due to a digital value change of 1 LSB count.

Writing the Control Program

Calculating the Digital Value

The control program must calculate the digital value that is sent to the analog output. Several methods can be used to do this, but the best method is to convert the values to engineering units. This is accomplished by using the formula shown.

Adjustments may have to be made to the formula depending on the scale of the engineering units.

$$A = U \frac{4095}{H - L} \text{ for } 0\text{--}4095 \text{ output format}$$

$$A = U \frac{2047}{H - L} \text{ for } 0\text{--}2047 \text{ output format}$$

A = Analog Value (0 – 4095)

U = Engineering Units

H = High limit of the engineering unit range

L = Low limit of the engineering unit range

Consider the following example which controls pressure from 0.0–99.9 psi. Using the formula will calculate the digital value to be sent to the analog output. The example shows the conversion required to yield 49.4 psi. The multiplier of 10 is because the decimal portion of 49.4 cannot be loaded in the program, so it is shifted right one decimal place to make a usable value of 494.

Refer to the example on the next page to write the conversion program.

$$A = 10U \frac{4095}{10(H - L)}$$

$$A = 494 \frac{4095}{1000 - 0}$$

$$A = 2023$$

The Conversion Program

This example program shows how to write the program to perform the engineering unit conversion to output data formats 0–4095. This example assumes that a BCD value has been stored in V2300 and V2301 for channels 1 and 2 respectively.



NOTE: The DL205 has many instructions available so that math operations can simply be performed using BCD format. Do the math in BCD, then convert to binary before writing to the module output.

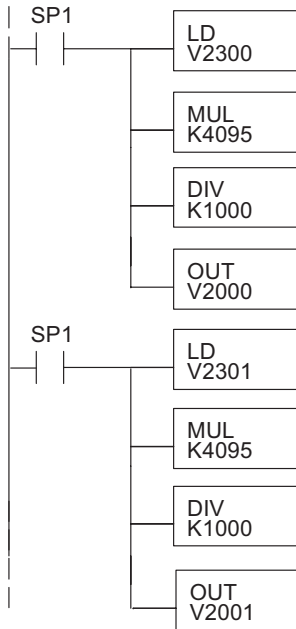

The LD instruction loads the engineering units used with channel 1 into the accumulator. This example assumes the numbers are BCD. Since SP1 is used, this rung automatically executes on every scan. You could also use an X, C, etc. permissive contact.

Multiply the accumulator by 4095 (to start the conversion).

Divide the accumulator by 1000 (because we used a multiplier of 10, we have to use 1000 instead of 100).

Store the BCD result in V2000 (the actual steps required to send the data are shown later).

The LD instruction loads the engineering units used with channel 2 into the accumulator. This example assumes the numbers are BCD. Since SP1 is used, this rung automatically executes on every scan. You could also use an X, C, etc. permissive contact.

Multiply the accumulator by 4095 (to start the conversion).

Divide the accumulator by 1000 (because we used a multiplier of 10, we have to use 1000 instead of 100).

Store the BCD result in V2001 (the actual steps required to send the data are shown later).

Negative Values with Bipolar Range

If the bipolar ranges ($\pm 5V$, $\pm 10V$) are used or an output data format of ± 2047 , the data value needs to be specified whether it is positive or negative. There are two ways to show that the value is negative:

- Turn on the sign output (Y37 in the examples, D2-230 only).
- Embed the sign output in the data value (required for the D2-240, D2-250-1, D2-260 and D2-262 using the pointer method, an optional method for the D2-230).

To embed the sign output in the data values, OR 8000 to the value. This has the same effect as turning on Y37. Remember, the V-memory location is mapped directly to the outputs.

If bipolar ranges are used, logic needs to be added to indicate either positive or negative values. The logic would be similar for both values, but some type of permissive contact needs to be used to select the appropriate section of logic. Following is an example that re-scales a variable from a 0–1000 range to a 0–2047 range. It includes a step that combines 8000 with the value to make it negative.



NOTE: Do not exceed a value of 2047 for ± 2047 output formats.

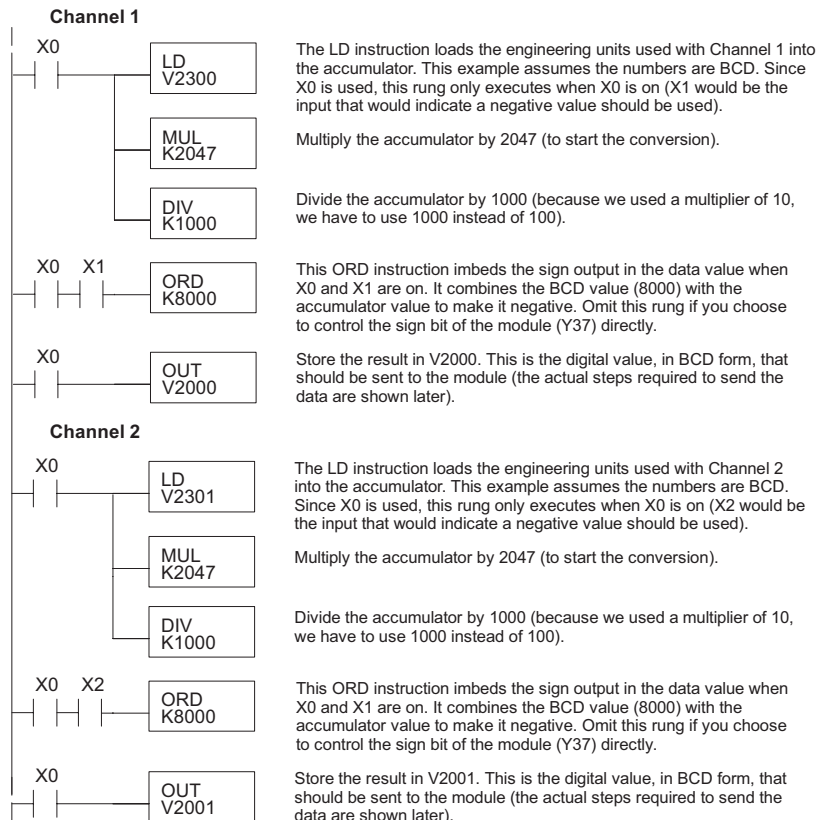

Writing Values: Pointer Method and Multiplexing

There are two methods which can be used to write values from the CPU to the module:

- The pointer method
- Multiplexing

The multiplexing method must be used when using a D2-230 CPU. The multiplexing method must also be used with remote I/O modules (the pointer method will not work). Either method can be used with the D2-240, D2-250-1, D2-260 and D2-262 CPUs, however, the pointer method will simplify programming the PLC.

Writing Values (Pointer Method) for D2-240, D2-250-1, D2-260 and D2-262 CPUs

The D2-240, D2-250-1, D2-260 and D2-262 CPUs have special V-memory locations assigned to each base slot that will greatly simplify the programming requirements.

These V-memory locations allow you to:

- Specify the data format
- Specify the number of channels to scan
- Specify the location of the data that will be written to the module



NOTE: D2-240 CPUs with firmware release version 1.5 or later and. D2-250-1 CPUs with firmware release version 1.06 or later support this method.

The following example program shows how to setup these locations. Place this rung anywhere in the ladder program, or in the initial stage if stage programming instructions are being used. V2000 is used in the example but any user V-memory location can be used. In this example the module is installed in slot 3. Be sure to use the V-memory locations for the module placement. The pointer method automatically converts values to BCD.

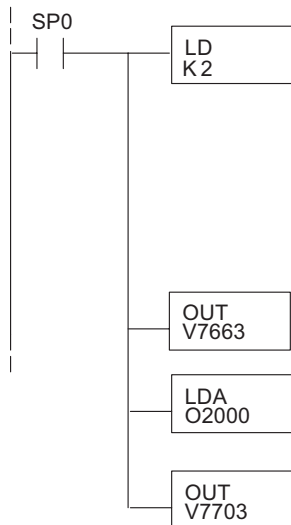

- or -

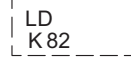

Loads a constant that specifies the number of channels to scan and the data format. The lower byte, most significant nibble (MSN) selects the data format (i.e. 0=BCD, 8=Binary), the LSN selects the number of channels (1 or 2).

The binary format is used for displaying data on some operator interfaces. The D2-230 and D2-240 CPUs do not support binary math functions, whereas the D2-250-1, D2-260, and D2-252 do.

Special V-memory location assigned to slot 3 that contains the number of channels to scan.

This loads an octal value for the first V-memory location that will be used to store the output data. For example, the O2000 entered here would designate the following addresses.

Ch1 - V2000, Ch2 - V2001

The octal address (O2000) is stored here. V7703 is assigned to slot 3 and acts as a pointer, which means the CPU will use the octal value in this location to determine exactly where to store the output data.

The following tables show the special V-memory locations used by the D2-240, D2-250-1, D2-260 and D2-262 for the CPU base and local expansion base I/O slots. Slot 0 (zero) is the module next to the CPU or D2-CM module. Slot 1 is the module two places from the CPU or D2-CM, and so on. Remember, the CPU only examines the pointer values at these locations after a mode transition. Also, if the D2-230 (multiplexing) method is used, verify that these addresses in the CPU are 0 (zero).

The table below applies to the D2-240, D2-250-1, D2-260 and D2-262 CPU base.

CPU Base: Analog Output Module Slot-Dependent V-memory Locations								
Slot	0	1	2	3	4	5	6	7
No. of Channels	V7660	V7661	V7662	V7663	V7664	V7665	V7666	V7667
Storage Pointer	V7700	V7701	V7702	V7703	V7704	V7705	V7706	V7707

The table below applies to the D2-250-1, D2-260 and D2-262 CPU base 1.

Expansion Base D2-CM #1: Analog Output Module Slot-Dependent V-memory Locations								
Slot	0	1	2	3	4	5	6	7
No. of Channels	V36000	V36001	V36002	V36003	V36004	V36005	V36006	V36007
Storage Pointer	V36020	V36021	V36022	V36023	V36024	V36025	V36026	V36027

The table below applies to the D2-250-1, D2-260 and D2-262 CPU base 2.

Expansion Base D2-CM #2: Analog Output Module Slot-Dependent V-memory Locations								
Slot	0	1	2	3	4	5	6	7
No. of Channels	V36100	V36101	V36102	V36103	V36104	V36105	V36106	V36107
Storage Pointer	V36120	V36121	V36122	V36123	V36124	V36125	V36126	V36127

The table below applies to the D2-260 and D2-262 CPU base 3.

Expansion Base D2-CM #3: Analog Output Module Slot-Dependent V-memory Locations								
Slot	0	1	2	3	4	5	6	7
No. of Channels	V36200	V36201	V36202	V36203	V36204	V36205	V36206	V36207
Storage Pointer	V36220	V36221	V36222	V36223	V36224	V36225	V36226	V36227

The table below applies to the D2-260 and D2-262 CPU base 4.

Expansion Base D2-CM #4: Analog Output Module Slot-Dependent V-memory Locations								
Slot	0	1	2	3	4	5	6	7
No. of Channels	V36300	V36301	V36302	V36303	V36304	V36305	V36306	V36307
Storage Pointer	V36320	V36321	V36322	V36323	V36324	V36325	V36326	V36327

Writing Data (Multiplexing)

The D2-230 CPU does not have the special V-memory locations that allows for automatic management of data transfer. Since all channels are multiplexed into a single data word, the control program must be written in such a way to determine which channel to write the data to. Since the module appears as Y output points to the CPU, it is very easy to use the channel selection outputs to determine which channel to update.

The following example is for a module installed as shown in previous examples. The addresses used would be different if the module were located in a different slot. These rungs can be placed anywhere in the user program or, if using stage programming, placed in an active stage.

This example is a two-channel multiplexer that updates each channel on alternate scans. Relay SP7 is a special relay that is on for one scan, then off for one scan. A permissive contact on the last rung handles an embedded sign bit.



NOTE: Use binary data to write to the module outputs. Do not use a BIN instruction if the data is already in binary format.

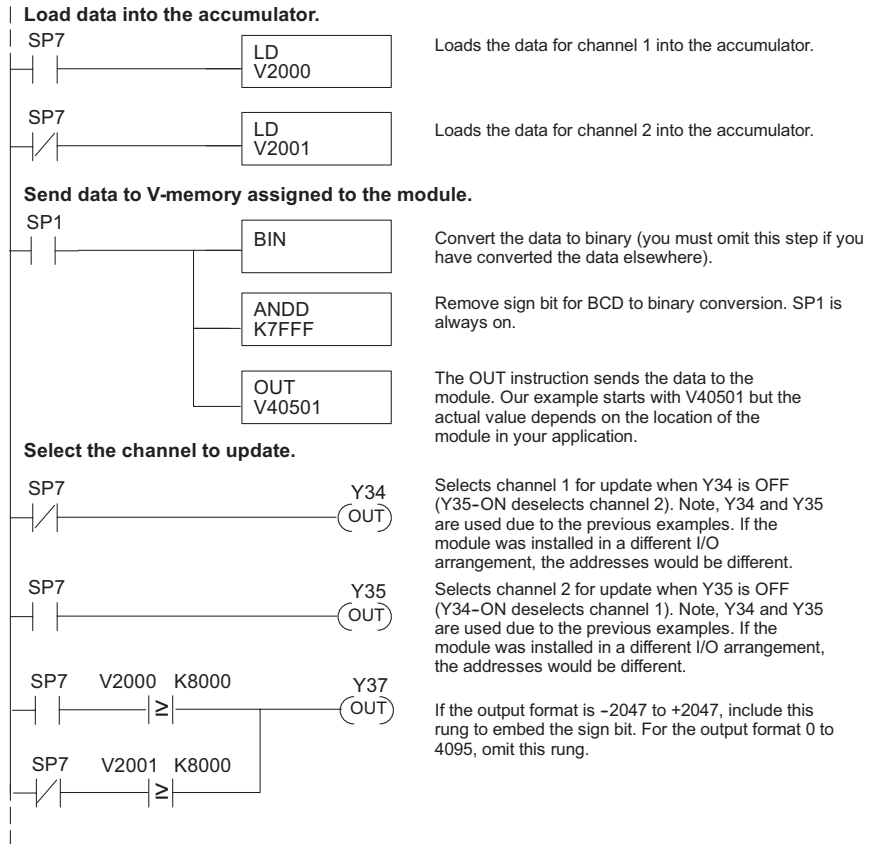

Chapter 9: F2-02DA-2, F2-02DA-2L, 2-Channel Analog Voltage Output

If the output range format of ± 2047 is used (also most commonly used with bipolar voltage ranges), the data values must be specified as either positive or negative. The previous example could be used with an addition to activate the sign output bit, or use the following example which uses individual contacts to determine the sign bit status for each channel.



WARNING: DO NOT USE THIS METHOD if the sign information is embedded into the data value by adding 8000 to it. Use the previous example.

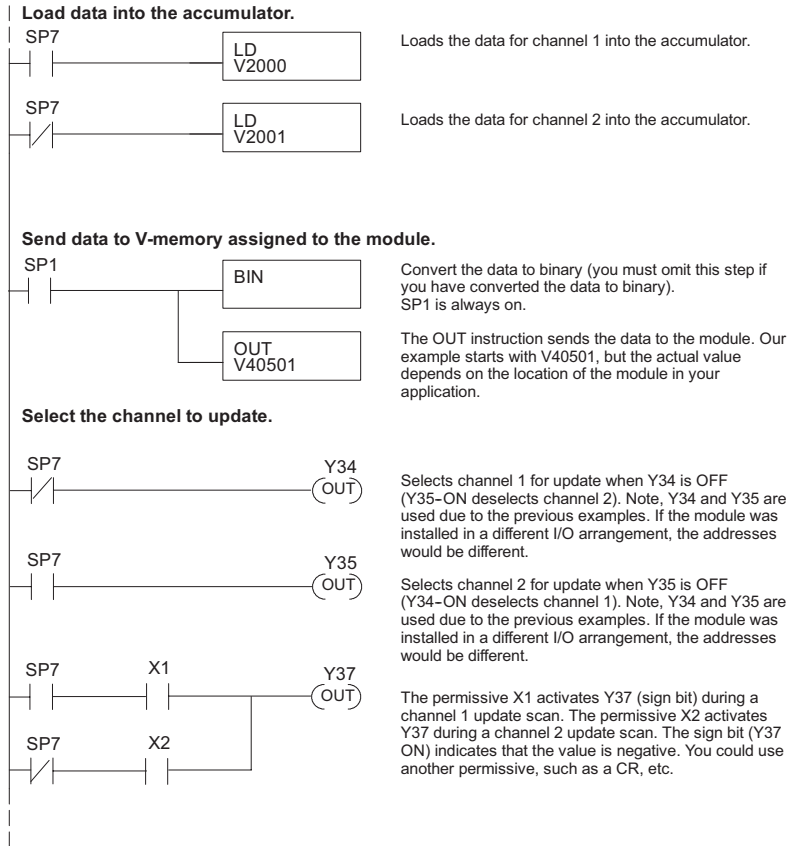

NOTE: Do not exceed a value of 2047 for ± 2047 output data formats.

Write Data to One Channel

The following example can be used if only one channel is to be written to, or if the outputs are to be controlled individually. Don't forget to either embed the sign information or use the sign output bit for bipolar ranges. In this example below, data is written to output channel 1.

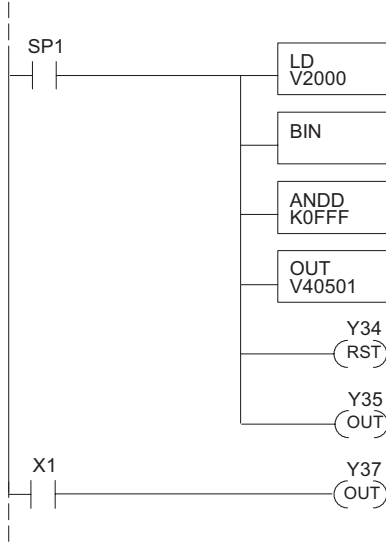

The LD instruction loads the data into the accumulator. Since SP1 is used, this rung automatically executes on every scan. You could also use an X, C, etc. permissive contact.

The BIN instruction converts the accumulator data to binary (you must omit this step if you have already converted the data elsewhere).

The ANDD instruction masks off the channel select bits to prevent an accidental channel selection.

The OUT instruction sends the data to the module. Our example starts with V40501, but the actual value depends on the location of the module in your application.

Y34-OFF selects channel 1 for updating.

Y35-ON deselects channel 2 (do not update).

The permissive X1 activates Y37, which is the sign bit. The sign bit indicates that the value is negative. You could use another permissive, such as a CR, etc. Omit this rung if you are using the 0 to +4095 output format.

Write Data to Both Channels

In the example below, if both selection channels are off, they will be updated with the same data. Remember to either embed the sign information or use the sign output bit.

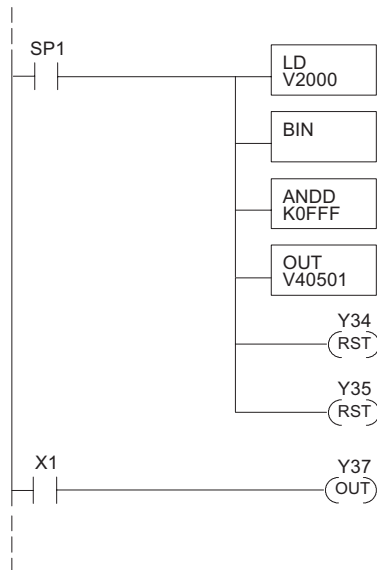

The LD instruction loads the data into the accumulator. Since SP1 is used, this rung automatically executes on every scan. You could also use an X, C, etc. permissive contact.

The BIN instruction converts the accumulator data to binary (you must omit this step if you have already converted the data elsewhere).

The ANDD instruction masks off the channel select bits to prevent an accidental channel selection.

The OUT instruction sends the data to the module. Our example starts with V40501, but the actual value depends on the location of the module in your application.

Y34-OFF selects channel 1 for updating.

Y35-OFF selects channel 2 for updating.

The permissive X1 activates Y37, which is the sign bit. The sign bit indicates that the value is negative. You could use another permissive, such as a CR, etc. Omit this rung if you are using the 0 to +4095 output format.

Analog and Digital Value Conversions

It is sometimes useful to do quick conversions between the signal levels and the digital values. This can be helpful during startup or troubleshooting. The following table shows some formulas to help with the conversions.

Range	The digital value is known	The analog signal level is known
0–10V	$A = 10D$ 4095	$D = \frac{4095 (A)}{10}$
$\pm 10V$ (output format ± 2047)	$A = 10D$ 2047	$D = \frac{2047 (A)}{10}$
0–5V	$A = 5D$ 4095	$D = \frac{4095 (A)}{5}$
$\pm 5V$ (output format ± 2047)	$A = 5D$ 2047	$D = \frac{2047 (A)}{5}$

For example, if a $\pm 10V$ range with an output format of ± 2047 is used, and a 6V signal level is needed, use the formula to the right to determine the digital value “D” to be stored in the V-memory location which contains the data.

$$D = \frac{2047 (A)}{10}$$

$$D = \frac{2047 (6V)}{10}$$

$$D = (204.7) (6)$$

$$D = 1228$$

F2-08DA-1, 8-CHANNEL ANALOG CURRENT OUTPUT



CHAPTER 10

In This Chapter...

Module Specifications	10-2
Connecting and Disconnecting the Field Wiring	10-5
Module Operation	10-7
Writing the Control Program.....	10-11

Module Specifications

The F2-08DA-1 Analog Output module provides several hardware features:

- Supported by D2-230, D2-240, D2-250-1, D2-260 and D2-262 CPUs (see firmware requirements).
- Analog outputs are optically isolated from the PLC logic.
- The module has a removable terminal block so the module can be easily removed or changed without disconnecting the wiring.
- All channels can be updated in one scan (D2-240, D2-250-1, D2-260 and D2-262 only).
- Outputs are both current sinking and sourcing.

Firmware Requirements:

- To use this module, D2-230 CPUs must have firmware version 2.7 or later.
- To use the pointer method for writing values, D2-240 CPUs require firmware version 3.0 or later.
- D2-250-1 CPU requires firmware version 1.33 or later.

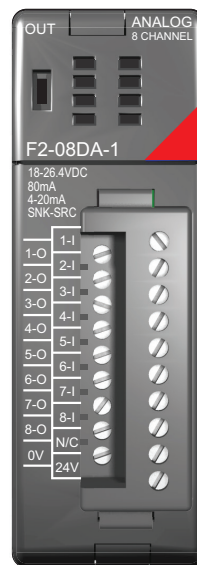

F2-08DA-1

Analog Output Configuration Requirements

The F2-08DA-1 analog output module requires 16 discrete output points. The module can be installed in any slot of a DL205 PLC system, but the available power budget and discrete I/O points can be the limiting factors. Check the user manual for the particular model of CPU and I/O base being used for information regarding power budget and number of local, local expansion or remote I/O points.

The following tables provide the specifications for the F2-08DA-1 Analog Output Module. Review these specifications to make sure the module meets your application requirements.

Output Specifications	
Number of Channels	8, single-ended
Output Range	4–20 mA
Resolution	12 bit (1 in 4096)
Output Type	Current sinking and current sourcing
Maximum Loop Supply	30VDC
Source Load	0–400 Ω (for loop power 18–30 V)
Sink Load	0–600 Ω / 18V, 900Ω / 24V, 1200Ω / 30V
Total Load (sink plus source)	600Ω / 18V, 900Ω / 24V, 1200Ω / 30V
Linearity Error (end to end)	±2 counts (±0.050% of full scale) maximum
Conversion Settling Time	400µs maximum (full scale change)
Full-scale Calibration Error	±12 counts maximum, sinking (any load) ±12 counts maximum, sourcing (125Ω load) ±18 counts maximum, sourcing (250Ω load) ±26 counts maximum, sourcing (400Ω load)
Offset Calibration Error	±9 counts maximum, sinking (any load) ±9 counts maximum, sourcing (125Ω load) ±11 counts maximum, sourcing (250Ω load) ±13 counts maximum, sourcing (400Ω load)
Maximum Full Scale Inaccuracy @ 0–60°C	0.5% sinking (any load) & sourcing (125Ω load) 0.64% sourcing (250Ω load) 0.83% sourcing (400Ω load)
Maximum Full Scale Inaccuracy @ 0–25°C (includes all errors & temperature drift)	0.3% sinking (any load) & sourcing (125Ω load) 0.44% sourcing (250Ω load) 0.63% sourcing (400Ω load)

General Specifications	
PLC Update Rate	8 channel per scan maximum
Digital Outputs / Output Points Required	12 binary data bits, 3 channel ID bits, 1 output enable bit 16 (Y) output points required
Power Budget Requirement	30mA @ 5VDC (supplied by the base)
External Power Supply	18–30 VDC, 50mA plus 20mA / output loop, class 2
Operating Temperature	0–60°C (32–140°F)
Storage Temperature	-20°C to 70°C (-4°F to 158°F)
Relative Humidity	5–95% (non-condensing)
Environmental air	No corrosive gases permitted
Vibration	MIL STD 810C 514.2
Shock	MIL STD 810C 516.2
Noise Immunity	NEMA ICS3-304

Special Placement Requirements (D2-230 and Remote I/O Bases)

It is important to examine the configuration if a D2-230 CPU is being used. As can be seen in the section on Writing the Control Program, V-memory locations are used to hold the analog data that will be written to the output. If the module is placed in a slot so that the output points do not start on a

V-memory boundary, the program instructions aren't able to access the data. This also applies when placing this module in a remote base using a D2-RSSS in the CPU slot.

Correct!

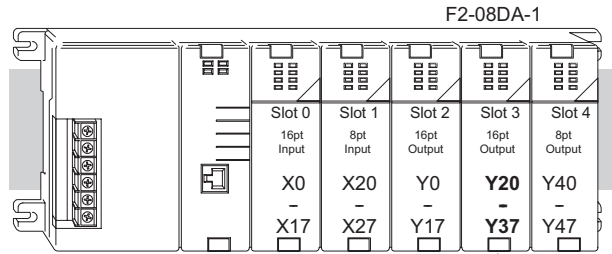

Data can be written correctly because the output points start on a V-memory boundary address as seen in the table below.

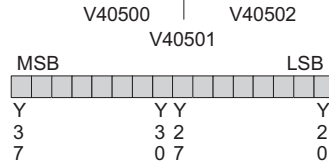

Incorrect

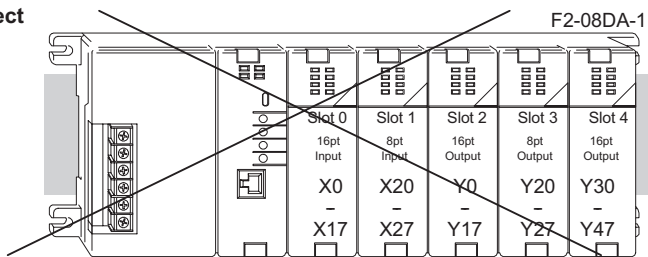

Data is split over two locations, so instructions cannot access data from a D2-230 (or when the module is placed in a remote base).

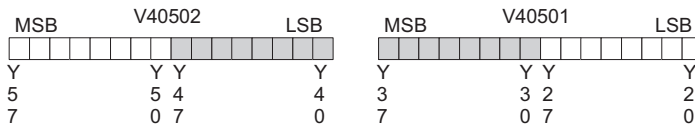

To use the V-memory references required for the multiplexing method, the first output address assigned to the module must be one of the following Y locations. The table also shows the V-memory addresses that correspond to these Y locations.

X	Y0	Y20	Y40	Y60	Y100	Y120	Y140	Y160
V	V40500	V40501	V40502	V40503	V40504	V40505	V40506	V40507

Connecting and Disconnecting the Field Wiring

Wiring Guidelines

Your company may have guidelines for wiring and cable installation. If so, check the guidelines before beginning the installation. Here are some general things to consider:

- Use the shortest wiring route whenever possible.
- Use shielded wiring and ground the shield at the transmitter source. Do not ground the shield at both the module and the source.
- Do not run the signal wiring next to large motors, high current switches, or transformers. This may cause noise problems.
- Route the wiring through an approved cable housing to minimize the risk of accidental damage. Check local and national codes to choose the correct method for your application.

User Power Supply Requirements

The F2-08DA-1 module requires at least one field-side power supply. The same or separate power sources can be used for the module supply and the current transmitter supply. The F2-08DA-1 module requires 18–30 VDC (at 50mA) and each current loop requires 18–30 VDC (at 20mA), from the external power supply.

The DL205 AC bases have a built-in 24VDC power supply that provides up to 300mA of current. This can be used instead of a separate supply. Check the power budget to be safe.

It is desirable in some situations to power the transmitters separately in a location remote from the PLC. This will work as long as the transmitter supply meets the required operating current and the transmitter negative (-) side and the module power supply negative (-) side are connected together.



WARNING: If the internal 24VDC power budget is exceeded, it may cause unpredictable system operation that can lead to a risk of personal injury or equipment damage.

Wiring Diagram

The F2-08DA-1 module has a removable connector which helps to simplify wiring. Just squeeze the top and bottom retaining clips and gently pull the connector from the module. Use the following diagram to connect the field wiring. Channels 1 and 2 are shown wired for sourcing, and channels 7 and 8 are shown wired for sinking. The diagram also shows how to wire an optional loop power supply.

Typical User Wiring

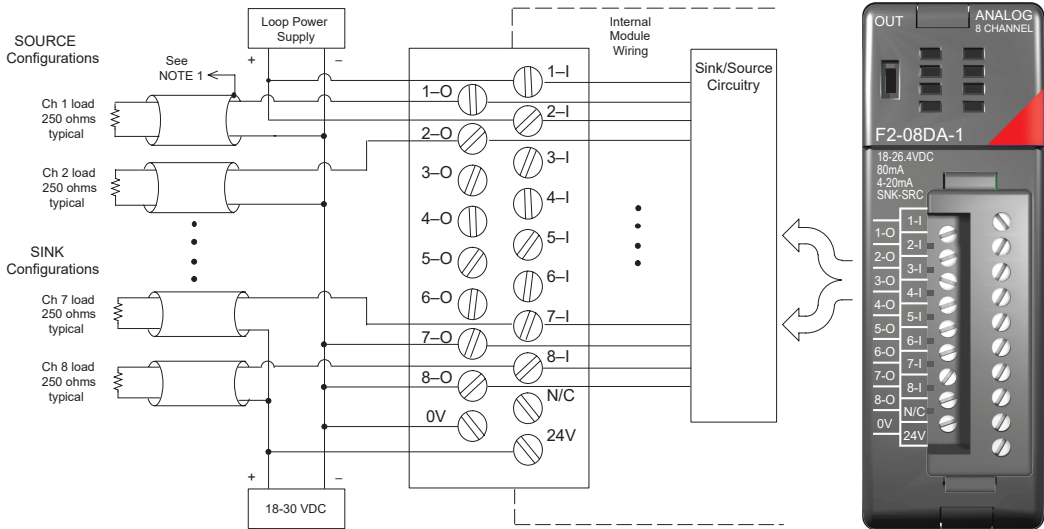

NOTE 1: Shields should be connected to the 0V terminal of the module.

Load Range

The maximum load resistance depends on the particular loop power supply being used.

Loop Power Supply Voltage	Source Load Range	Sink Load Range
30VDC	0-400 Ω	0-1200 Ω
24VDC		0-900 Ω
18VDC		0-600 Ω

Module Operation

Before beginning to write the control program, it is important to take a few minutes to understand how the module processes the analog signals.

Channel Scanning Sequence (Multiplexing) for a D2-230 CPU

The D2-230 can send one channel of data to the output per CPU scan if the multiplexing method is used. The module refreshes all field devices on each scan, but new data can only be obtained from the CPU at the rate of one channel per scan. Since there are eight channels, it can take eight scans to update all channels. However, if only one channel is being used, then that channel will be updated on every scan. The multiplexing method can also be used for the D2-240, D2-250-1, D2-260 and D2-262 CPUs.

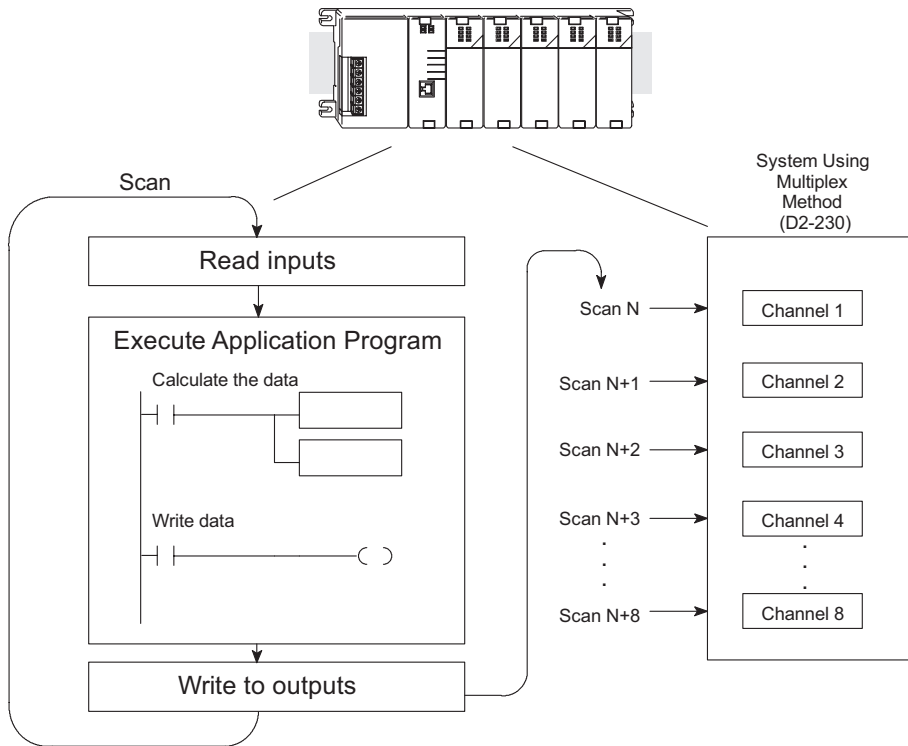

Channel Scanning Sequence (Pointer Method) for D2-240, D2-250-1, D2-260 and D2-262 CPUs

If either a D2-240, D2-250-1, D2-260 or D2-262 CPU is used, all channels can be updated on every scan. This is because the all three CPUs support special V-memory locations that are used to manage the data transfer. This is discussed in more detail in the section on Writing the Control Program later in this chapter.

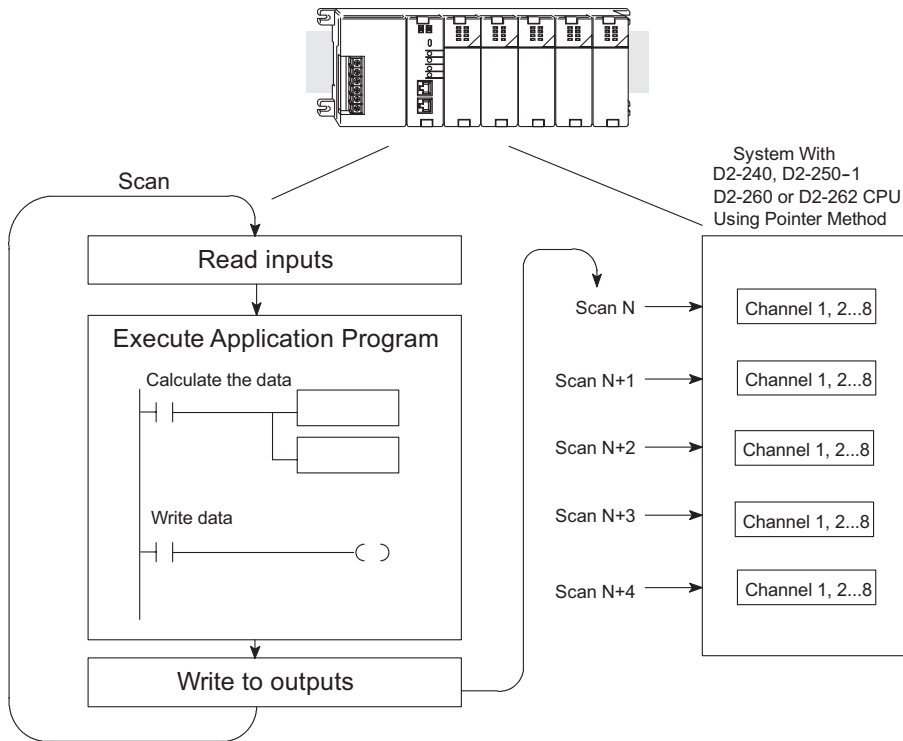

Understanding the Output Assignments

Remember that the F2-08DA-1 module appears to the CPU as a 16-point discrete output module. These points provide the data value and an indication of which channel to update. Note, if either a D2-240, D2-250-1, D2-260 or a D2-262 CPU is being used, these bits may never have to be used, but it may be an aid to help understand the data format.

Since all output points are automatically mapped into V-memory, the location of the data word that will be assigned to the module can be simply determined.

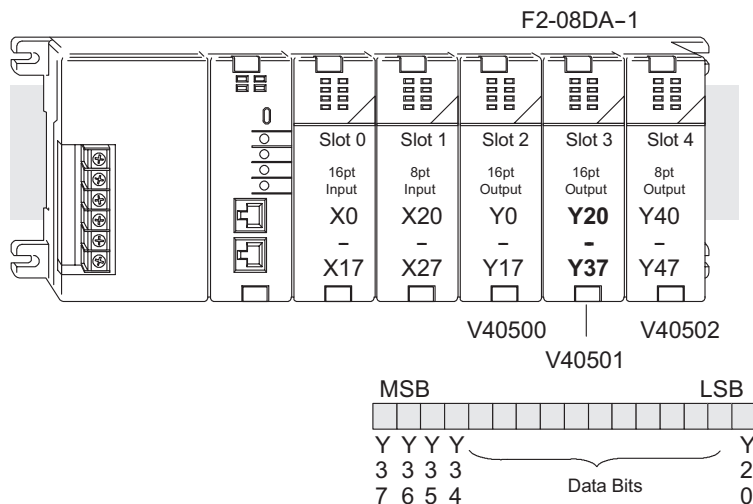

The individual bits in this data word location, represents specific information about the analog signal.

Channel Select Outputs

Three of the outputs select the active channel. Remember, the V-memory bits are mapped directly to discrete outputs. The binary weight of the three bits will determine the selected bit. By controlling these outputs, the channel to be updated can be selected.

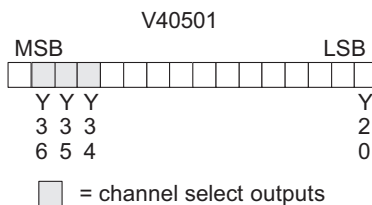

Select Channel Outputs			
Y36	Y35	Y34	Channel Number Selected
-	-	-	1
-	-	X	2
-	X	-	3
-	X	X	4
X	-	-	5
X	-	X	6
X	X	-	7
X	X	X	8

Analog Data Bits

The first twelve bits represent the analog data in binary format.

Bit	Value	Bit	Value
0	1	6	64
1	2	7	128
2	4	8	256
3	8	9	512
4	16	10	1024
5	32	11	2048

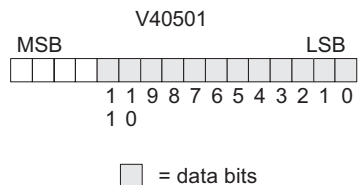

Output Enable

The last output can be used to update outputs. If the output is OFF, the outputs will be cleared.

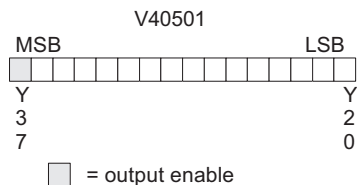

Module Resolution

Since the module has 12-bit resolution, the analog signal is converted into 4096 counts ranging from 0–4095 (2¹²). For example, send a 0 to get a 4mA signal, and 4095 to get a 20mA signal. This is equivalent to a binary value of 0000 0000 0000 to 1111 1111 1111, or 000 to FFF hexadecimal. The diagram shows how this relates to the signal range. Each count can also be expressed in terms of the signal level by using the equation shown.

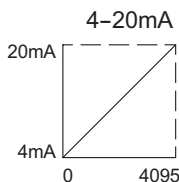

$$\text{Resolution} = \frac{H - L}{4095}$$

H = high limit of the signal range

L = low limit of the signal range

$$16\text{mA}/4095 = 3.9 \mu\text{A per count}$$

Writing the Control Program

Calculating the Digital Value

The control program must calculate the digital value that is sent to the analog output. Several methods can be used to do this, but the best method is to convert the values to engineering units. This is accomplished by using the formula shown.

Adjustments may have to be made to the formula depending on the scale of the engineering units.

For 0-4095 output format

$$A = U \frac{4095}{H - L}$$

A = Analog Value (0-4095)
 U = Engineering Units
 H = High limit of the engineering unit range
 L = Low limit of the engineering unit range

Consider the following example which controls pressure from 0.0–99.9 psi. Using the formula will calculate the digital value to be sent to the analog output. The example shows the conversion required to yield 49.4 psi. The multiplier of 10 is used because the decimal portion of 49.4 cannot be loaded in the program, so it is shifted right one decimal place to make a usable value of 494.

$$A = 10U \frac{4095}{10(H-L)} \qquad A = 494 \frac{4095}{(1000-0)} \qquad A = 2023$$

The Conversion Program

The example program shows how to write the program to perform the engineering unit conversion. This example assumes that a BCD value has been stored in V2300 and V2301 for channels 1 and 2 respectively.



NOTE: The DL205 has many instructions available so that math operations can simply be performed using BCD format. Do the math in BCD, then convert to binary before writing to the module output.

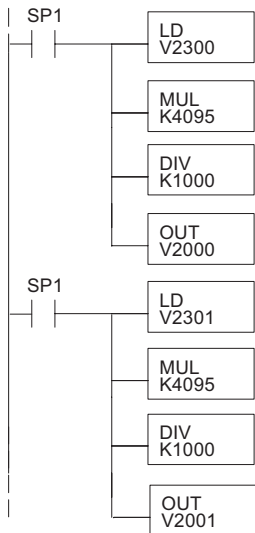

The LD instruction loads the engineering units used with channel 1 into the accumulator. This example assumes the numbers are BCD. Since SP1 is used, this rung automatically executes on every scan. You could also use an X, C, etc. permissive contact.

Multiply the accumulator by 4095 (to start the conversion).

Divide the accumulator by 1000 (because we used a multiplier of 10, we have to use 1000 instead of 100).

Store the BCD result in V2000 (the actual steps required to send the data are shown later).

The LD instruction loads the engineering units used with channel 2 into the accumulator. This example assumes the numbers are BCD. Since SP1 is used, this rung automatically executes on every scan. You could also use an X, C, etc. permissive contact.

Multiply the accumulator by 4095 (to start the conversion).

Divide the accumulator by 1000 (because we used a multiplier of 10, we have to use 1000 instead of 100).

Store the BCD result in V2001 (the actual steps required to send the data are shown later).

Writing Values: Pointer Method and Multiplexing

Pointer Method for the D2-240, D2-250-1, D2-260 and D2-262 CPUs

There are two methods of reading values:

- Pointer method
- Multiplexing

The multiplexing method must be used with a D2-230 CPU. The multiplexing method must also be used with remote I/O modules (the pointer method will not work). Either method can be used with the D2-240, D2-250-1, D2-260 and D2-262 CPUs, but for ease of programming it is highly recommended to use the pointer method.

The D2-240, D2-250-1, D2-260 and D2-262 CPUs have special V-memory locations assigned to each base slot that will greatly simplify the programming requirements.

These V-memory locations allow you to:

- Specify the data format
- Specify the number of channels to scan
- Specify the location of the data that will be written to the module



NOTE: D2-240 CPUs with firmware release version 1.5 or later and. D2-250-1 CPUs with firmware release version 1.06 or later support this method.

The following example program shows how to setup these locations. Place this rung anywhere in the ladder program, or in the initial stage if stage programming instructions are being used. V2000 is used in the example but any user V-memory location can be used. In this example the module is installed in slot 3. Be sure to use the V-memory locations for the module placement. The pointer method automatically converts values to BCD.

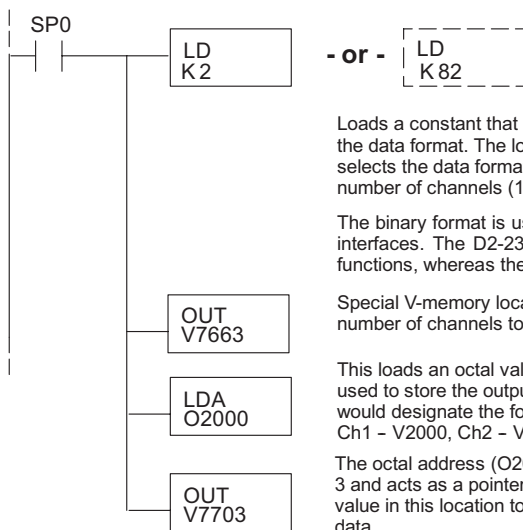

- or -

Loads a constant that specifies the number of channels to scan and the data format. The lower byte, most significant nibble (MSN) selects the data format (i.e. 0=BCD, 8=Binary), the LSN selects the number of channels (1 or 2).

The binary format is used for displaying data on some operator interfaces. The D2-230 and D2-240 CPUs do not support binary math functions, whereas the D2-250-1, D2-260, and D2-262 do.

Special V-memory location assigned to slot 3 that contains the number of channels to scan.

This loads an octal value for the first V-memory location that will be used to store the output data. For example, the O2000 entered here would designate the following addresses.
Ch1 - V2000, Ch2 - V2001

The octal address (O2000) is stored here. V7703 is assigned to slot 3 and acts as a pointer, which means the CPU will use the octal value in this location to determine exactly where to store the output data.

The following tables show the special V-memory locations used by the D2-240, D2-250-1, D2-260 and D2-262 for the CPU base and local expansion base I/O slots. Slot 0 (zero) is the module next to the CPU or D2-CM module. Slot 1 is the module two places from the CPU or D2-CM, and so on. Remember, the CPU only examines the pointer values at these locations after a mode transition. Also, if the D2-230 (multiplexing) method is used, verify that these addresses in the CPU are 0 (zero).

The table below applies to the D2-240, D2-250-1, D2-260 and D2-262 CPU base.

CPU Base: Analog Output Module Slot-Dependent V-memory Locations								
Slot	0	1	2	3	4	5	6	7
No. of Channels	V7660	V7661	V7662	V7663	V7664	V7665	V7666	V7667
Storage Pointer	V7700	V7701	V7702	V7703	V7704	V7705	V7706	V7707

The table below applies to the D2-250-1, D2-260 or the D2-262 CPU base 1.

Expansion Base D2-CM #1: Analog Output Module Slot-Dependent V-memory Locations								
Slot	0	1	2	3	4	5	6	7
No. of Channels	V36000	V36001	V36002	V36003	V36004	V36005	V36006	V36007
Storage Pointer	V36020	V36021	V36022	V36023	V36024	V36025	V36026	V36027

The table below applies to the D2-250-1, D2-260 or the D2-262 CPU base 2.

Expansion Base D2-CM #2: Analog Output Module Slot-Dependent V-memory Locations								
Slot	0	1	2	3	4	5	6	7
No. of Channels	V36100	V36101	V36102	V36103	V36104	V36105	V36106	V36107
Storage Pointer	V36120	V36121	V36122	V36123	V36124	V36125	V36126	V36127

The table below applies to the D2-260 and D2-262 CPU base 3.

Expansion Base D2-CM #3: Analog Output Module Slot-Dependent V-memory Locations								
Slot	0	1	2	3	4	5	6	7
No. of Channels	V36200	V36201	V36202	V36203	V36204	V36205	V36206	V36207
Storage Pointer	V36220	V36221	V36222	V36223	V36224	V36225	V36226	V36227

The table below applies to the D2-260 and D2-262 CPU base 4.

Expansion Base D2-CM #4: Analog Output Module Slot-Dependent V-memory Locations								
Slot	0	1	2	3	4	5	6	7
No. of Channels	V36300	V36301	V36302	V36303	V36304	V36305	V36306	V36307
Storage Pointer	V36320	V36321	V36322	V36323	V36324	V36325	V36326	V36327

Writing Data (Multiplexing Example)

The following example program shows how to write data using the multiplexing method. This may be used with all the DL205 CPUs.

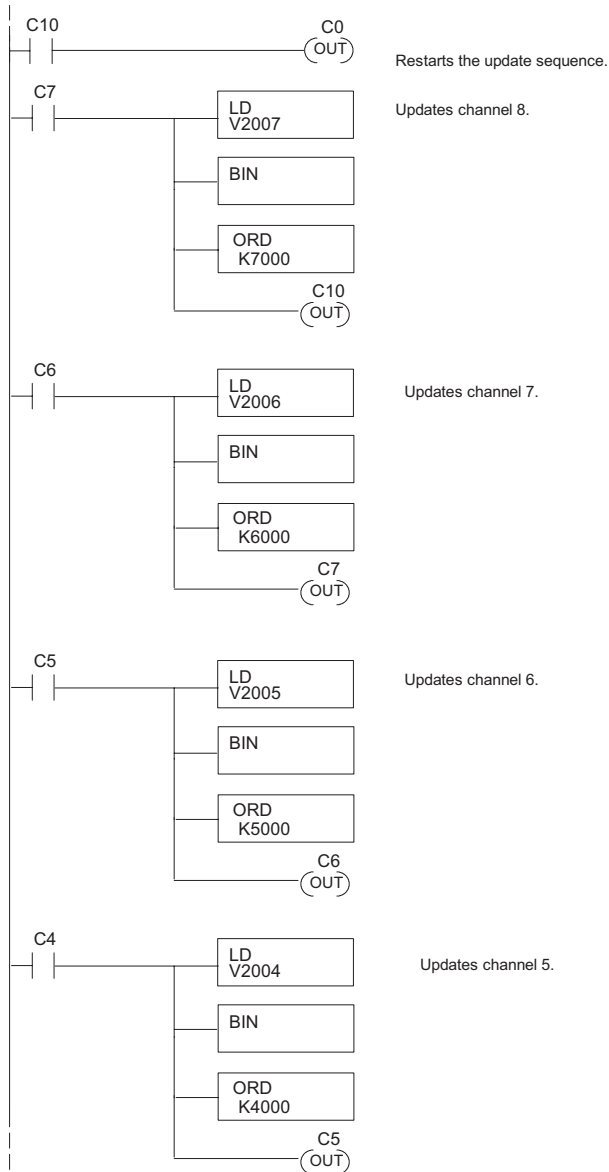

Continued

Write Data (Multiplexing Example) Continued

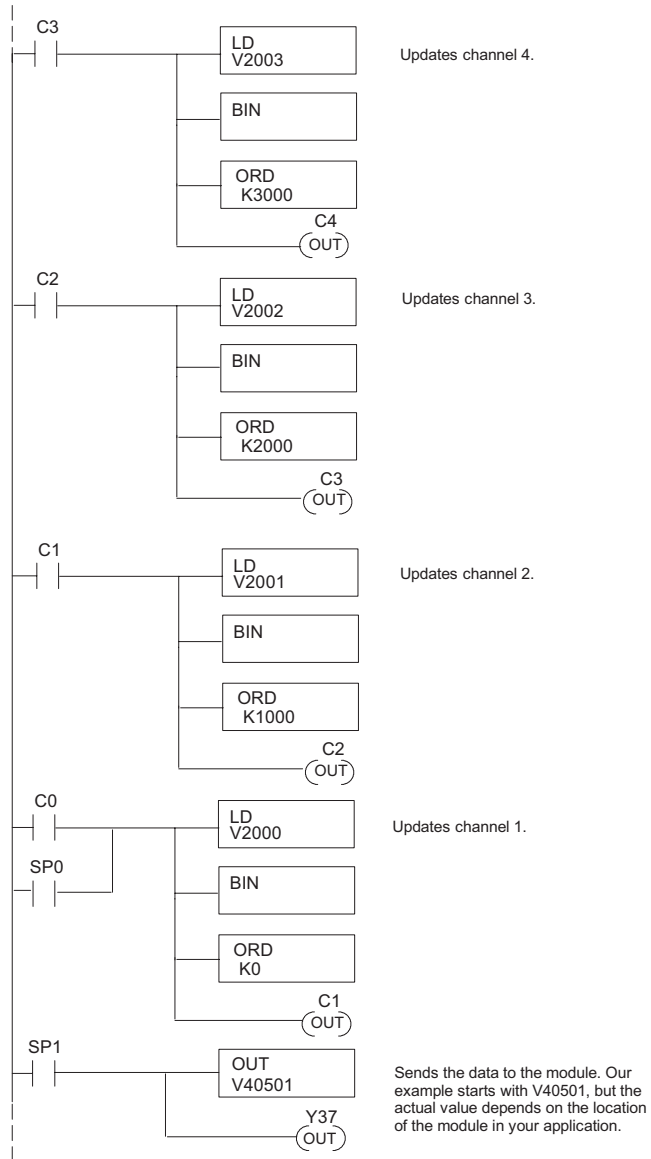

Write Data to One Channel

If more than one channel is used, or if updates are to be controlled separately, the following program can be used.

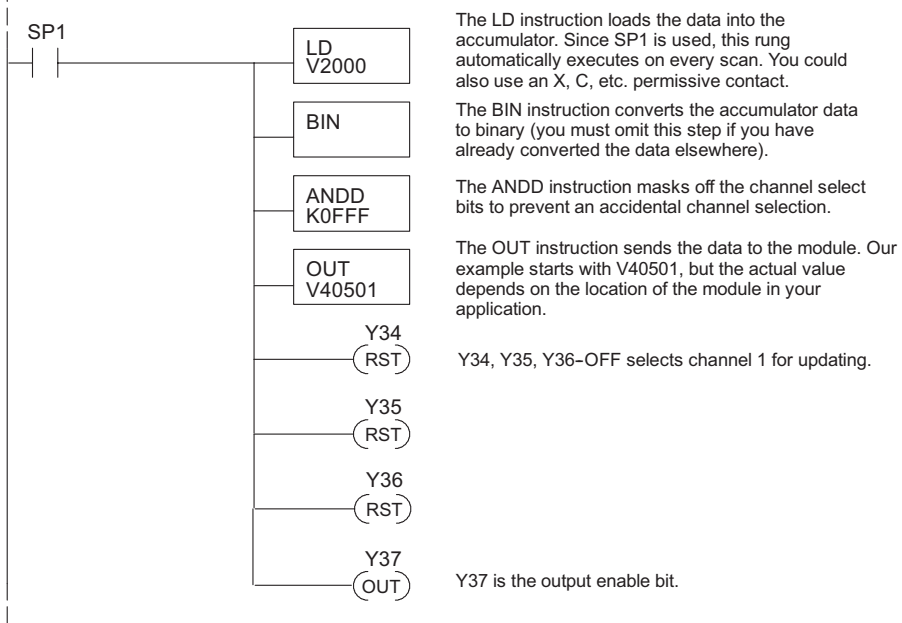

Analog and Digital Value Conversions

It is sometimes useful to do quick conversions between the signal levels and the digital values. This can be helpful during startup or troubleshooting. The following table shows some formulas help with the conversions.

Range	If the digital value is known	If the analog signal level is known.
4–20 mA	$A = 16D + 4$ 4095	$D = \frac{4095(A - 4)}{16}$

For example, to convert a 10mA signal level to a digital value, substitute 10 for A and complete the math as shown in the example to the right.

$$D = \frac{4095}{16} (A - 4)$$

$$D = \frac{4095}{16} (10\text{mA} - 4)$$

$$D = (255.93) (6)$$

$$D = 1536$$

F2-08DA-2, 8-CHANNEL ANALOG VOLTAGE OUTPUT



In This Chapter...

Module Specifications	11-2
Setting the Module Jumpers	11-5
Connecting the Field Wiring.....	11-6
Module Operation	11-8
Writing the Control Program.....	11-12

Module Specifications

The F2-08DA-2 Analog Output module provides several hardware features:

- Analog outputs are optically isolated from the PLC logic.
- The module has a removable terminal block so the module can be easily removed or changed without disconnecting the wiring.
- All channels can be updated in one scan if either a D2-240, a D2-250-1, a D2-260 or a D2-262 CPU is used in the PLC.
- Outputs are voltage sourcing.
- Outputs can be configured for either of the following ranges:
 1. 0–5 VDC
 2. 0–10 VDC

Firmware Requirements:

- To use this module, D2-230 CPUs must have firmware version 2.7 or later.
- To use the pointer method for writing values, D2-240 CPUs require firmware version 3.0 or later.
- D2-250-1, D2-260, and D2-262 CPUs require firmware version 1.33 or later.

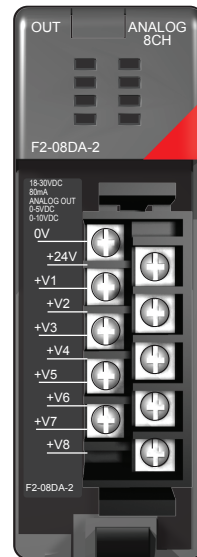

F2-08DA-2

The following tables provide the specifications for the F2-08DA-2 Analog Output Module. Review these specifications to make sure the module meets your application requirements.

Output Specifications	
Number of Channels	8, single-ended
Output Range	0-5 V, 0-10 V
Resolution	12 bit (1 in 4096)
Output Type	Voltage sourcing
Peak Output Voltage	15VDC (clamped by transient voltage suppressor)
Load Impedance	1k Ω (0-5 V range); 10k Ω (0-10 V range)
Load Capacitance	0.01 μ F maximum
Linearity Error (end to end)	± 1 count ($\pm 0.025\%$ of full scale) maximum
Conversion Settling Time	400 μ s maximum (full scale change) 4.5 - 9.0 ms for digital out to analog out
Full-scale Calibration Error (offset error included)	± 12 counts maximum, @ 25°C (77°F)
Offset Calibration Error	± 3 counts maximum, @ 25°C (77°F)
Maximum Inaccuracy	$\pm 0.3\%$ @ 25°C (77°F) $\pm 0.45\%$ 0-60°C (32-140°F)
Accuracy vs. Temperature	± 57 ppm/°C full scale calibration change (Including maximum offset change of 2 counts)

General Specifications	
PLC Update Rate	1 channel per scan maximum (multiplexing) 8 channels per scan maximum (pointer - D2-240/D2-250-1/D2-260 and D2-262 only)
Digital Outputs / Output Points Required	12 binary data bits, 3 channel ID bits, 1 output enable bit; 16 (Y) output points required
Power Budget Requirement	60mA @ 5VDC (supplied by the base)
External Power Supply	24VDC($\pm 10\%$), 140mA (outputs fully loaded)
Operating Temperature	0-60°C (32-140°F)
Storage Temperature	-20°C to 70°C (-4°F to 158°F)
Relative Humidity	5-95% (non-condensing)
Environmental Air	No corrosive gases permitted
Vibration	MIL STD 810C 514.2
Shock	MIL STD 810C 516.2
Noise Immunity	NEMA ICS3-304

Analog Output Configuration Requirements

The F2-08DA-2 analog output module requires 16 discrete output points. The module can be installed in any slot of a DL205 PLC, but the available power budget and discrete I/O points are the limiting factors. Check the DL205 PLC User Manual for the particular model of CPU and I/O base being used for information regarding power budget and number of local base, local expansion base or remote I/O points.

Special Placement Requirements (D2-230 and Remote I/O Bases)

It is important to examine the configuration if a D2-230 CPU is being used. As can be seen in the section on Writing the Control Program, V-memory locations are used to hold the analog data that will be written to the output. If the module is placed in a slot so that the output points do not start on a V-memory boundary, the program instructions aren't able to access the data. This also applies when placing this module in a remote base using a D2-RSSS in the CPU slot.

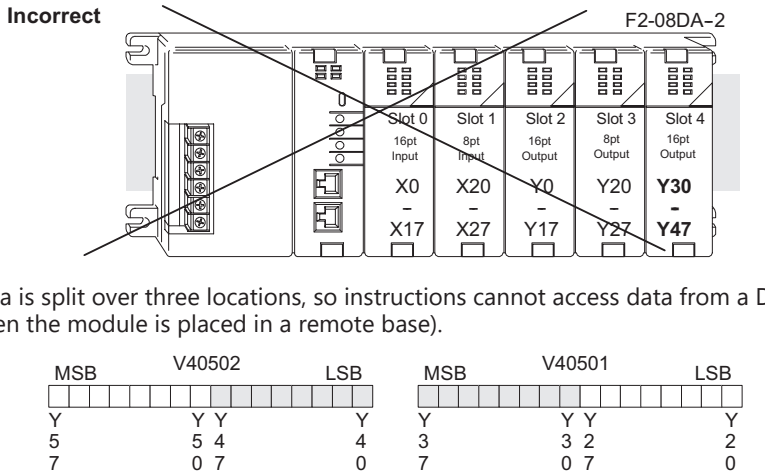
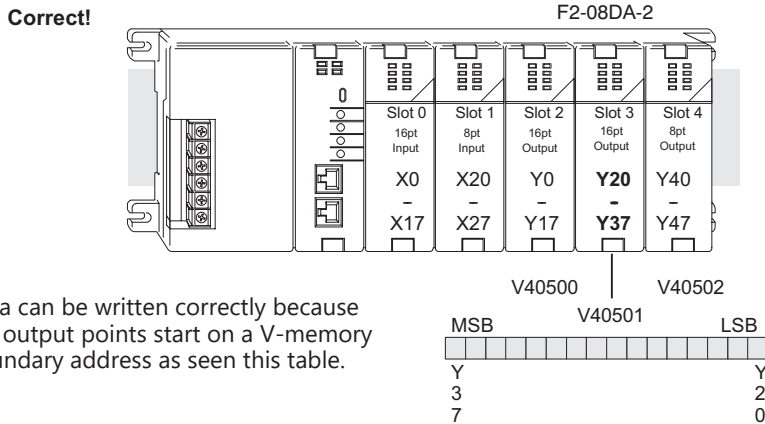

To use the V-memory references required for a D2-230 CPU, the first output address assigned to the module must be one of the following Y locations. The table also shows the V-memory addresses that correspond to these Y locations.

Y	Y0	Y20	Y40	Y60	Y100	Y120	Y140	
V	V40500	V40501	V40502	V40503	V40504	V40505	V40506	V40507

Setting the Module Jumpers

The F2-08DA-2 Analog Output module uses a jumper for selecting the voltage ranges of 0–5 V or 0–10 V.

This figure shows the jumper locations. See the table on the following page to determine the proper settings for your application.

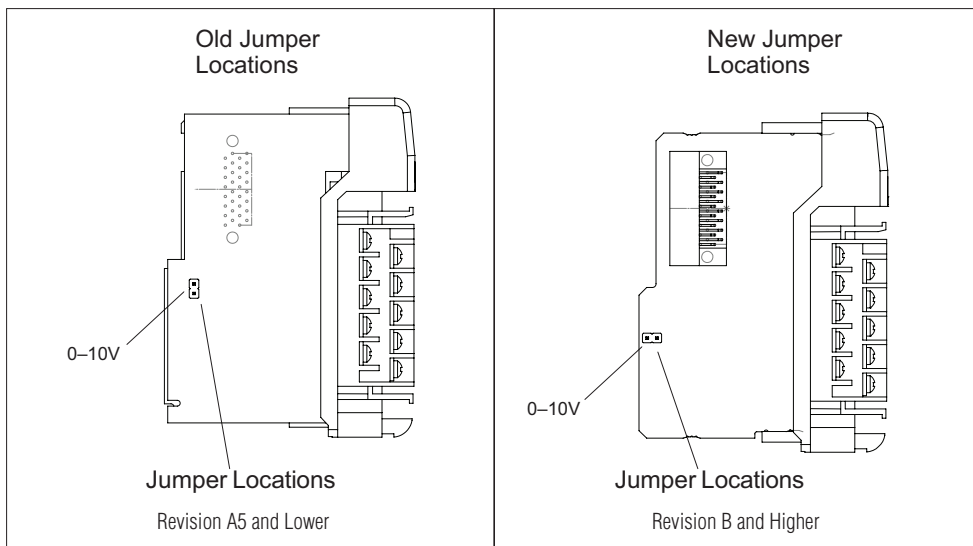

Voltage Range and Output Combinations

The table lists both possible combinations of voltage ranges and data formats, along with the corresponding jumper settings.

Voltage Range	Output Data Format	Jumper Setting (top board)
0-5V	0-4095	Install
0-10V	0-4095	Remove

The following graphs show the voltage range to output data format relationship for each of the two selections.

Ranges

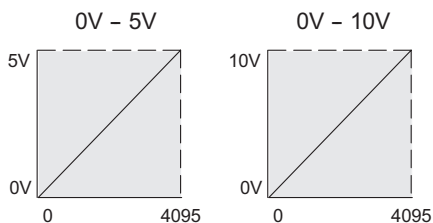

Connecting the Field Wiring

Wiring Guidelines

Your company may have guidelines for wiring and cable installation. If so, check the guidelines before beginning the installation. Here are some general things to consider:

- Use the shortest wiring route whenever possible.
- Use shielded wiring and ground the shield at the transmitter source. Do not ground the shield at both the module and the source.
- Do not run the signal wiring next to large motors, high current switches, or transformers. This may cause noise problems.
- Route the wiring through an approved cable housing to minimize the risk of accidental damage. Check local and national codes to choose the correct method for your application.

User Power Supply Requirements

The F2-08DA-2 module requires at least one field-side power supply. The same or separate power sources can be used for the module supply and the voltage transmitter supply. The F2-08DA-2 module requires 21.6-26.4 VDC (at 140 mA), from the external power supply.

The DL205 AC bases have a built-in 24VDC power supply that provide up to 300 mA of current. This can be used instead of a separate supply. Check the power budget to be safe.

It is desirable in some situations to power the transmitters separately in a location remote from the PLC. This will work as long as the transmitter supply meets the current requirements, and the transmitter's minus (-) side and the module supply's minus (-) side are connected together.



WARNING: If the internal 24VDC base power is used, be sure to calculate the power budget. Exceeding the power budget can cause unpredictable system operation that can lead to a risk of personal injury or equipment damage.

Wiring Diagram

The F2-08DA-2 module has a removable connector which helps to simplify wiring. Squeeze the top and bottom retaining clips and gently pull the connector from the module. Use the following diagram to connect the field wiring.

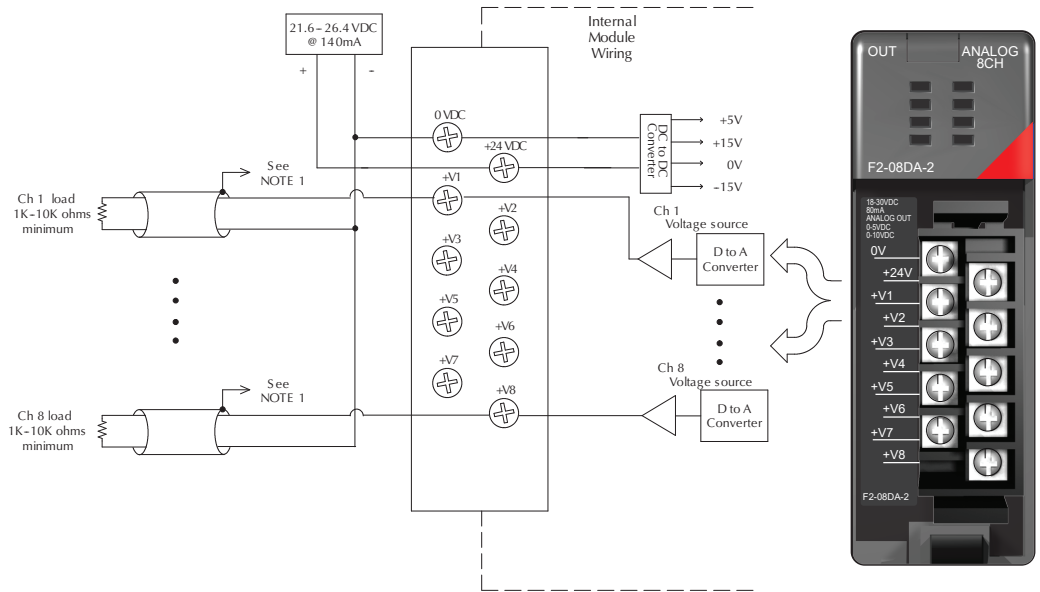

NOTE 1: Shields should be connected to the 0V terminal of the module or 0V of the power supply.

Module Operation

Before beginning to write the control program, it is important to take a few minutes to understand how the module processes the analog signals.

Channel Update Sequence (Multiplexing) for a D2-230 CPU

If a multiplexing program is being used, only one channel of data can be sent to the output module on each scan. The module refreshes both field devices on each scan, but new data can only be obtained from the CPU at the rate of one channel per scan. Since there are eight channels, it can take eight scans to update all channels. However, if only one channel is being used, that channel will be updated on every scan. The multiplexing method can also be used for the D2-240, D2-250-1, D2-260 and D2-262 CPUs.

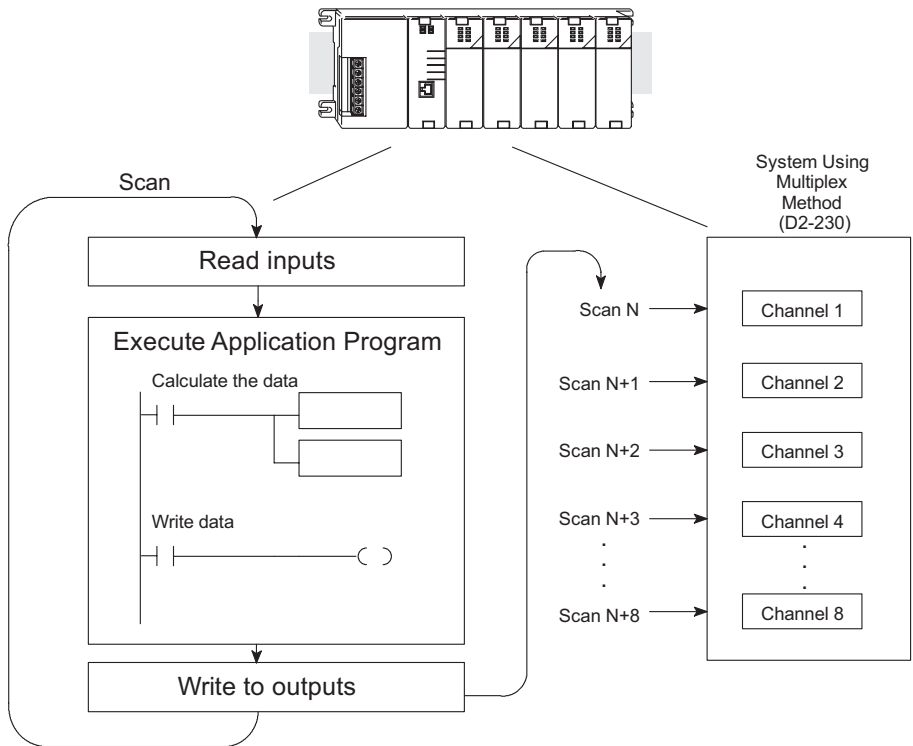

Channel Update Sequence (Pointer Method) for D2-240, D2-250-1, D2-260 and D2-262 CPUs

If either a D2-240, D2-250-1, D2-260 or a D2-262 CPU is used with the pointer method, all channels can be updated on every scan. This is because the three CPUs support special V-memory locations that are used to manage the data transfer. This is discussed in more detail in the section on Writing the Control Program later in this chapter.

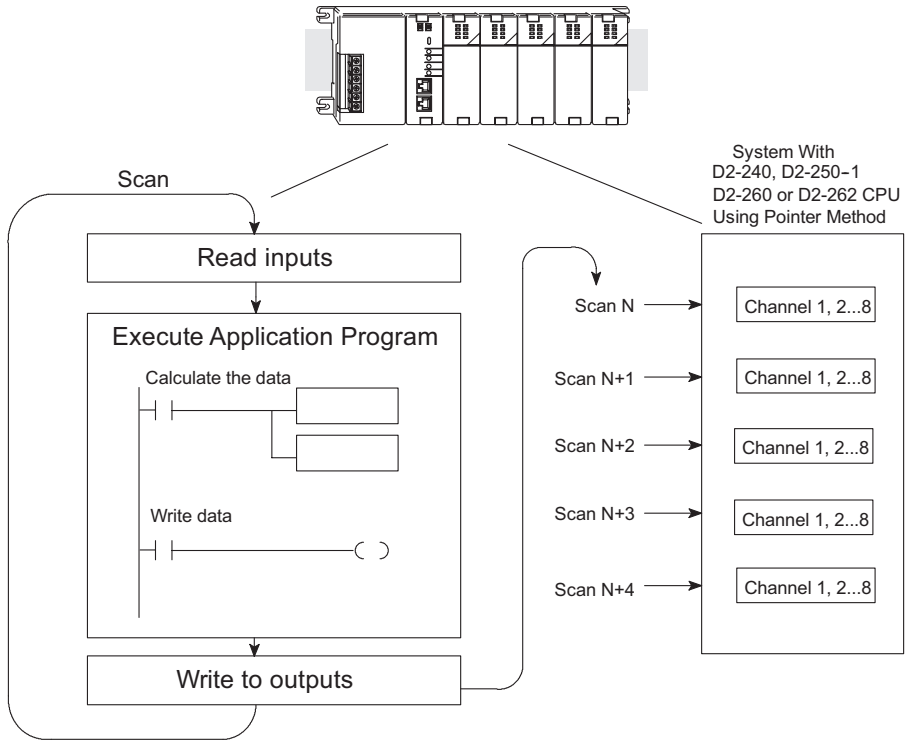

Understanding the Output Assignments

Remember that the F2-08DA-2 module appears to the CPU as a 16-point discrete output module. These points provide the data value and an indication of which channel to update. Note, if either a D2-240, D2-250-1, D2-260 or a D2-262 CPU is being used, these bits may never have to be used, but it may be an aid to help understand the data format.

Since all output points are automatically mapped into V-memory, the location of the data word that will be assigned to the module can be simply determined.

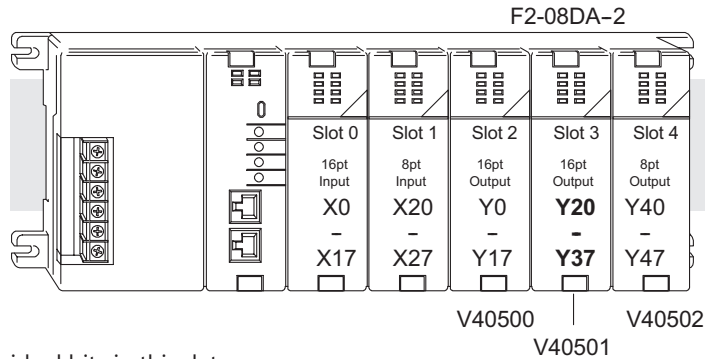

The individual bits in this data word location, represents specific information about the analog signal.

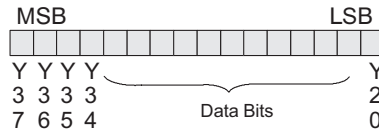

Channel Select Outputs

Three of the outputs select the active channel. Remember, the V-memory bits are mapped directly to discrete outputs. The binary weight of these three bits determines which channel is selected. The channel to be updated is controlled by these three outputs.

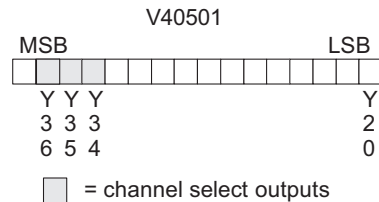

Select Channel Outputs			
Y36	Y35	Y34	Channel Number Selected
-	-	-	1
-	-	X	2
-	X	-	3
-	X	X	4
X	-	-	5
X	-	X	6
X	X	-	7
X	X	X	8

Analog Data Bits

The first twelve bits represent the analog data in binary format.

Bit	Value	Bit	Value
0	1	6	64
1	2	7	128
2	4	8	256
3	8	9	512
4	16	10	1024
5	32	11	2048

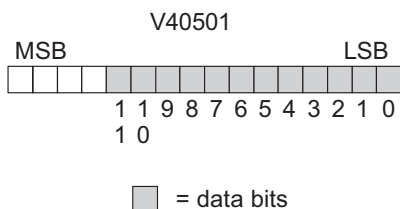

Output Enable

The last output can be used to update outputs. If this output is OFF, the outputs are cleared.

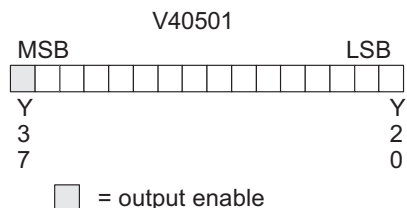

Module Resolution

Since the module has 12-bit resolution, the analog signal is converted into 4096 counts ranging from 0–4095 (212). For example, for a 0–10 V range, send a 0 to get a 0V signal, and 4095 to get a 10V signal. This is equivalent to a binary value of 0000 0000 0000 to 1111 1111 1111, or 000 to FFF hexadecimal.

Each count can also be expressed in terms of the signal level by using the equation shown.

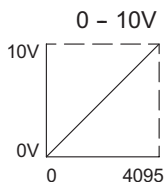

$$\text{Resolution} = \frac{H - L}{4095}$$

H = High limit of the signal range

L = Low limit of the signal range

The table below shows the smallest change in signal level due to a digital value change of 1 LSB count.

Voltage Range	Signal Span	Divide By	Smallest Output Change
0-5V	5 volts	4095	1.22 mV
0-10V	10 volts	4095	2.44 mV

Writing the Control Program

Calculating the Digital Value

The control program must calculate the digital value that is sent to the analog output. Several methods can be used to do this, but the best method is to convert the values to engineering units. This is accomplished by using the formula shown.

Adjustments may need to be made to the formula depending on the scale of the engineering units.

$$A = U \frac{4095}{H-L} \text{ for 0-4095 output format}$$

A = Analog Value (0 - 4095)

U = Engineering Units

H = High limit of the engineering unit range

L = Low limit of the engineering unit range

Consider the following example which controls pressure from 0.0 – 99.9 psi. Using the formula will calculate the digital value to be sent to the analog output. The example shows the conversion required to yield 49.4 psi. The multiplier of 10 is because the decimal portion of 49.4 cannot be loaded in the program, so it is shifted right one decimal place to make a usable value of 494.

$$A = 10U \frac{4095}{10(H-L)} \quad A = 494 \frac{4095}{(1000-0)} \quad A = 2023$$

Refer to the example on the next page to write the conversion program.

The Conversion Program

This example program shows how to write the program to perform the engineering unit conversion to output data formats 0–4095. This example assumes that a BCD value has been stored in V2300 and V2301 for channels 1 and 2 respectively.



NOTE: The DL205 has many instructions available so that math operations can simply be performed using BCD format. Do the math in BCD, then convert to binary before writing to the module output.

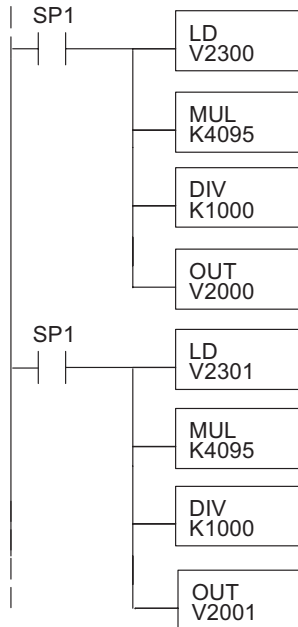

The LD instruction loads the engineering units used with channel 1 into the accumulator. This example assumes the numbers are BCD. Since SP1 is used, this rung automatically executes on every scan. You could also use an X, C, etc. permissive contact.

Multiply the accumulator by 4095 (to start the conversion).

Divide the accumulator by 1000 (because we used a multiplier of 10, we have to use 1000 instead of 100).

Store the BCD result in V2000 (the actual steps required to send the data are shown later).

The LD instruction loads the engineering units used with channel 2 into the accumulator. This example assumes the numbers are BCD. Since SP1 is used, this rung automatically executes on every scan. You could also use an X, C, etc. permissive contact.

Multiply the accumulator by 4095 (to start the conversion).

Divide the accumulator by 1000 (because we used a multiplier of 10, we have to use 1000 instead of 100).

Store the BCD result in V2001 (the actual steps required to send the data are shown later).

Writing Values: Pointer Method and Multiplexing

There are two methods of reading values:

- Pointer method
- Multiplexing

The multiplexing method must be used with a D2-230 CPU. The multiplexing method must also be used with remote I/O modules (the pointer method will not work). Either method can be used with the D2-240, D2-250-1, D2-260 and D2-262 CPUs, but for ease of programming it is highly recommended to use the pointer method.

Pointer Method for the D2-240, D2-250-1, D2-260 and D2-262 CPUs

The D2-240, D2-250-1, D2-260 and D2-262 CPUs have special V-memory locations assigned to each base slot that will greatly simplify the programming requirements.

These V-memory locations allow you to:

- Specify the data format
- Specify the number of channels to scan
- Specify the location of the data that will be written to the module



NOTE: D2-240 CPUs with firmware release version 3.0 or later and. D2-250-1 CPUs with firmware release version 1.33 or later support this method.

The following example program shows how to setup these locations. Place this rung anywhere in the ladder program, or in the initial stage if stage programming instructions are being used. V2000 is used in the example but any user V-memory location can be used. In this example the module is installed in slot 3. Be sure to use the V-memory locations for the module placement. The pointer method automatically converts values to BCD.

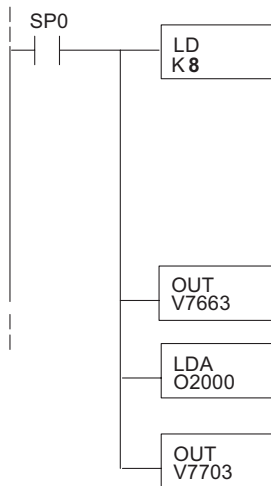

- or -

LD K88
Loads a constant that specifies the number of channels to scan and the data format. The lower byte, most significant nibble (MSN) selects the data format (0=BCD, 8=Binary), the LSN selects the number of channels (1-8).

The binary format is used for displaying data on some operator interfaces. The D2-230 and D2-240 CPUs do not support binary math functions, whereas the D2-250-1, D2-260, and D2-262 do.

Special V-memory location assigned to slot 3 that contains the number of channels to scan.

This loads an octal value for the first V-memory location that will be used to store the output data. For example, the O2000 entered here would designate the following addresses:
Ch1 - V2000, Ch 2 - V2001.....Ch8 - V2007

The octal address (O2000) is stored here. V7703 is assigned to slot 3 and acts as a pointer, which means the CPU will use the octal value in this location to determine exactly where to store the output data.

The following tables show the special V-memory locations used by the D2-240, D2-250-1, D2-260 and D2-262 for the CPU base and local expansion base I/O slots. Slot 0 (zero) is the module next to the CPU or D2-CM module. Slot 1 is the module two places from the CPU or D2-CM, and so on. Remember, the CPU only examines the pointer values at these locations after a mode transition. Also, if the D2-230 (multiplexing) method is used, verify that these addresses in the CPU are 0 (zero).

The table below applies to the D2-240, D2-250-1, D2-260 or the D2-262 CPU base.

CPU Base: Analog Output Module Slot-Dependent V-memory Locations								
Slot	0	1	2	3	4	5	6	7
No. of Channels	V7660	V7661	V7662	V7663	V7664	V7665	V7666	V7667
Storage Pointer	V7700	V7701	V7702	V7703	V7704	V7705	V7706	V7707

The table below applies to the D2-250-1, D2-260 or the D2-262 CPU base 1.

Expansion Base D2-CM #1: Analog Output Module Slot-Dependent V-memory Locations									
Slot	0	1	2	3	4	5	6	7	
No. of Channels	V36000	V36001	V36002	V36003	V36004	V36005	V36006	V36007	
Storage Pointer	V36020	V36021	V36022	V36023	V36024	V36025	V36026	V36027	

The table below applies to the D2-250-1, D2-260 or the D2-262 CPU base 2.

Expansion Base D2-CM #2: Analog Output Module Slot-Dependent V-memory Locations									
Slot	0	1	2	3	4	5	6	7	
No. of Channels	V36100	V36101	V36102	V36103	V36104	V36105	V36106	V36107	
Storage Pointer	V36120	V36121	V36122	V36123	V36124	V36125	V36126	V36127	

The table below applies to the D2-260 and D2-262 CPU base 3.

Expansion Base D2-CM #3: Analog Output Module Slot-Dependent V-memory Locations									
Slot	0	1	2	3	4	5	6	7	
No. of Channels	V36200	V36201	V36202	V36203	V36204	V36205	V36206	V36207	
Storage Pointer	V36220	V36221	V36222	V36223	V36224	V36225	V36226	V36227	

The table below applies to the D2-260 and D2-262 CPU base 4.

Expansion Base D2-CM #4: Analog Output Module Slot-Dependent V-memory Locations									
Slot	0	1	2	3	4	5	6	7	
No. of Channels	V36300	V36301	V36302	V36303	V36304	V36305	V36306	V36307	
Storage Pointer	V36320	V36321	V36322	V36323	V36324	V36325	V36326	V36327	

Writing Data Example (Multiplexing)

The following example shows how to write the data to be sent to the output using the multiplexing method. This can be used with all DL205 CPUs.

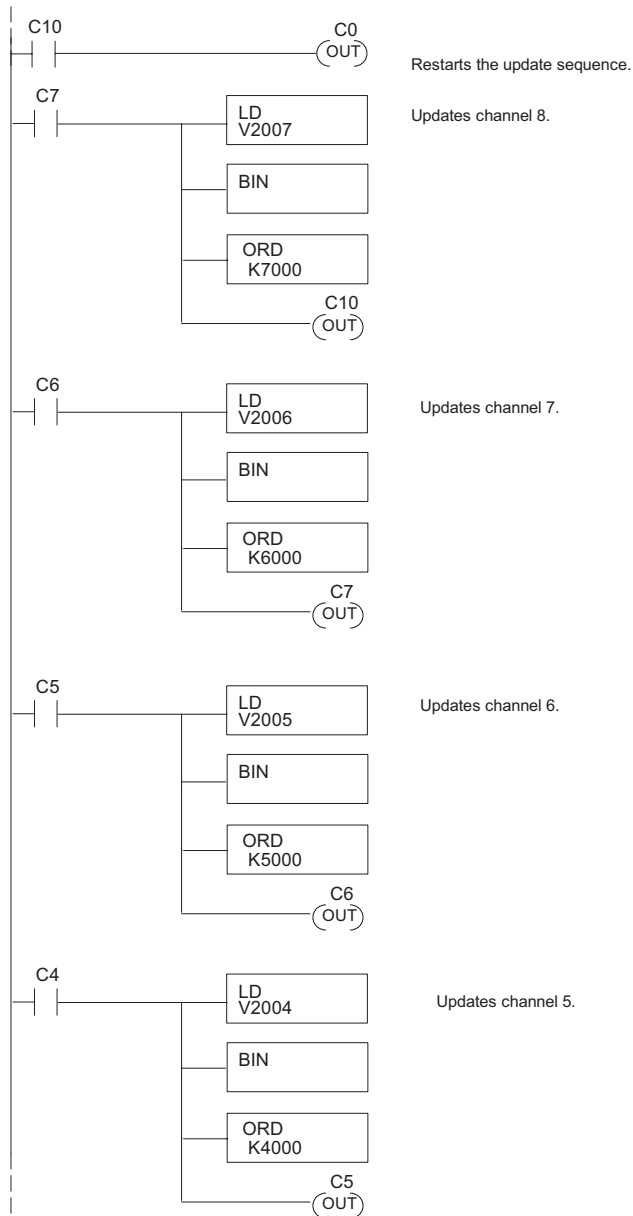

Continued

Writing Data Example (Multiplexing) continued

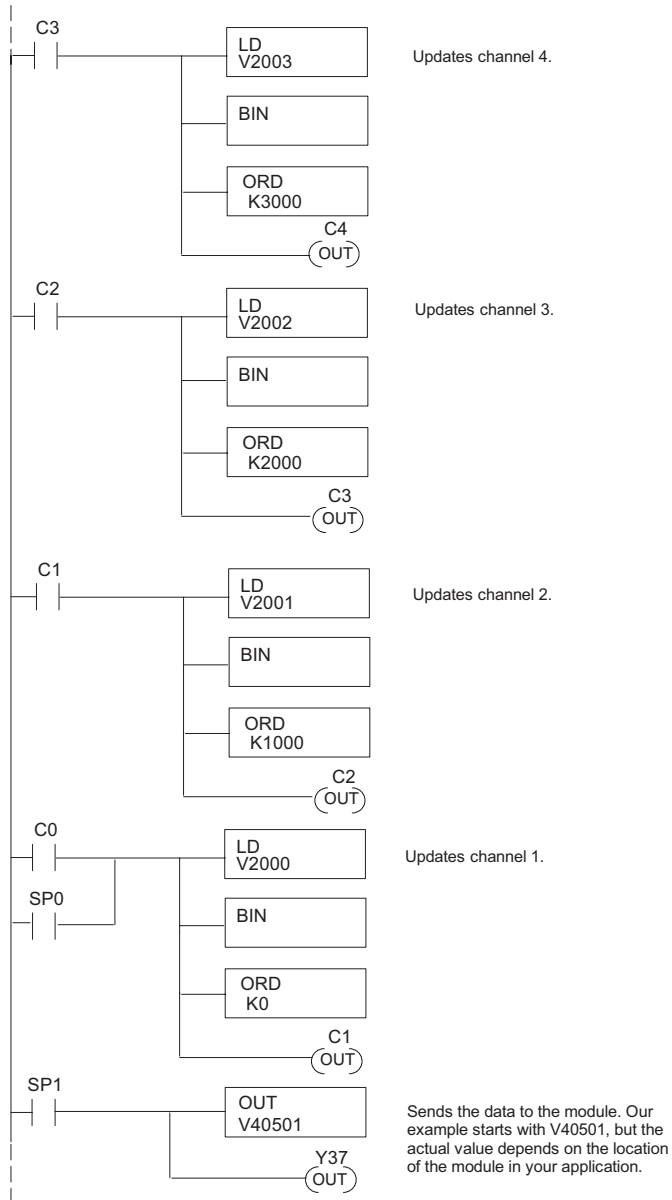

Write Data to One Channel

The following example can be used if only one channel is to be written to, or if the outputs are to be controlled individually. Don't forget to either embed the sign information or use the sign output bit for bipolar ranges.

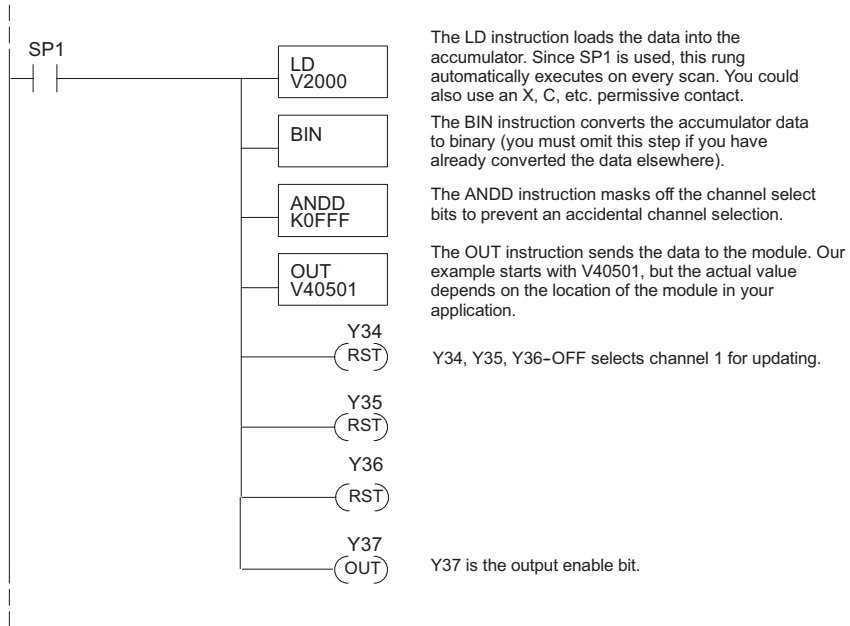

Analog and Digital Value Conversions

It is sometimes useful to do quick conversions between the signal levels and the digital values. This can be helpful during startup or troubleshooting. The following table shows some formulas to help with the conversions.

Range	If the digital value is known	If the analog signal level is known.
0-10V	$A = \frac{10D}{4095}$	$D = \frac{4095}{10} (A)$
0-5V	$A = \frac{5D}{4095}$	$D = \frac{4095}{5} (A)$

For example, if a 0–10 V range is used, and a 6V signal level is needed, use the formula to the right to determine the digital value “D” to be stored in the V-memory location which contains the data.

$$D = \frac{4095}{10} (A)$$

$$D = \frac{4095}{10} (6V)$$

$$D = (409.5) (6)$$

$$D = 2457$$

F2-02DAS-1, ISOLATED 2-CHANNEL ANALOG CURRENT OUTPUT



In This Chapter...

Module Specifications	12-2
Connecting the Field Wiring.....	12-5
Module Operation	12-7
Writing the Control Program.....	12-11

Module Specifications

The F2-02DAS-1 Analog Output module provides several hardware features:

- Analog outputs are isolated from channel to channel and channel to PLC logic.
- The module has a removable terminal block so the module can be easily removed or changed without disconnecting the wiring.
- All channels can be updated in one scan if either a D2-240, a D2-250-1, D2-260 or a D2-262 CPU is used in the PLC.
- Outputs are sourced through external loop supply.
- Loop power supply requirements: 18–32 VDC

Firmware Requirements:

- To use this module, D2-230 CPUs must have firmware version 1.7 or later.
- To use the pointer method for writing values, D2-240 CPUs require firmware version 2.9 or later.
- D2-250 CPUs require firmware version 1.30 or later.

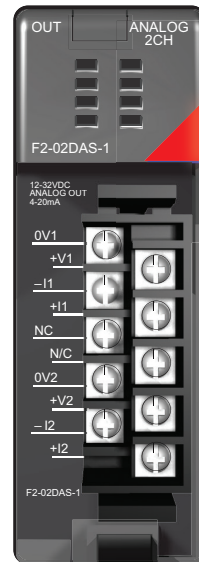

F2-02DAS-1

The following tables provide the specifications for the F2-02DAS -1, Isolated Analog Output Module.

Output Specifications	
Number of Channels	2, isolated (2 commons)
Output Range	4–20 mA
Resolution	16 bit (1 in 65536)
Output Type	Current sourcing
Isolation Voltage	±750V continuous, channel to channel, channel to logic
Loop Supply	18–32 VDC
Max Load Impedance	525Ω
Linearity Error (end to end)	±10 counts (±0.015% of full scale) maximum
Conversion Settling Time	3ms to 0.1% of full scale
Gain Calibration Error	±32 counts (±0.05%)
Offset Calibration Error	±13 counts (±0.02%)
Output Drift	50ppm / °C
Maximum Inaccuracy	±0.07% @ 25°C (77°F) ±0.18% 0–60 °C (32–140 °F)

General Specifications	
PLC Update Rate	1 channel per scan maximum (multiplexing) 2 channels per scan maximum (pointer – D2-240/D2-250-1/D2-260 and D2-262 only)
Digital Outputs / Output Points Required	16 binary data bits, 2 channel ID bits; 32 point (Y) output module
Power Budget Requirement	100mA @ 5VDC (supplied by the base)
External Power Supply	18–32 VDC, 50mA per channel, Class 2
Operating Temperature	0–60 °C (32–140 °F)
Storage Temperature	-20°C to 70°C (-4°F to 158°F)
Relative Humidity	5–95% (non-condensing)
Environmental Air	No corrosive gases permitted
Vibration	MIL STD 810C 514.2
Shock	MIL STD 810C 516.2
Noise Immunity	NEMA ICS3-304

Analog Output Configuration Requirements

The F2-02DAS-1 analog output module requires 32 discrete output points. The module can be installed in any slot of a DL205 system, but the available power budget and discrete I/O points are the limiting factors. Check the DL205 PLC User Manual for the particular model of CPU and I/O base being used for information regarding power budget and number of local, local expansion or remote I/O points.

Special Placement Requirements (D2-230 and Remote I/O Bases)

It is important to examine the configuration if a D2-230 CPU is being used in a multiplexing program. As can be seen in the section on Writing the Control Program, V-memory locations are used to hold the analog data that will be written to the output. If the module is placed in a slot so that the output points do not start on a V-memory boundary, the program instructions aren't able to access the data. This also applies when placing this module in a remote base using a D2-RSSS in the CPU slot.

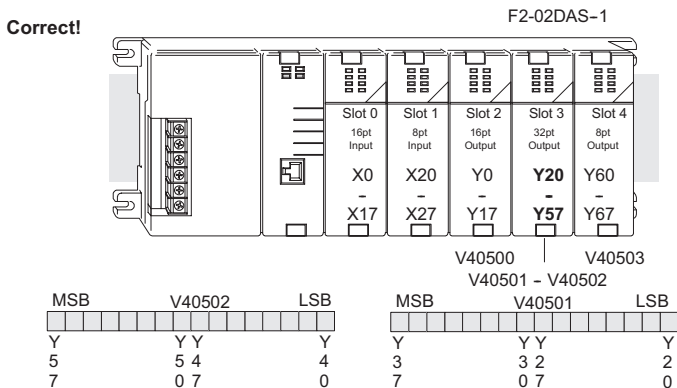

Data can be written correctly because the output points start on a V-memory boundary address as seen in the table above.

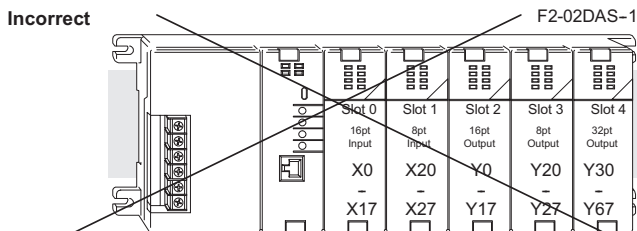

Data is split over three locations, so instructions cannot access data from a D2-230 (or when module is placed in a remote I/O base).



To use the V-memory references required for a D2-230 CPU, the first output address assigned to the module must be one of the following Y locations. The table also shows the V-memory addresses that correspond to these Y locations.

Y	Y0	Y20	Y40	Y60	Y100	Y120	Y140	Y160
V	V40500	V40501	V40502	V40503	V40504	V40505	V40506	V40507

Connecting the Field Wiring

Wiring Guidelines

Your company may have guidelines for wiring and cable installation. If so, check the guidelines before beginning the installation. Here are some general things to consider:

- Use the shortest wiring route whenever possible.
- Use shielded wiring and ground the shield at the transmitter source. Do not ground the shield at both the module and the source.
- Do not run the signal wiring next to large motors, high current switches, or transformers. This may cause noise problems.
- Route the wiring through an approved cable housing to minimize the risk of accidental damage. Check local and national codes to choose the correct method for your application.

Loop Power Supply Requirements

The F2-02DAS-1 module requires at least one field-side power supply. Separate power sources should be used to maintain the channel to channel isolation. The F2-02DAS-1 module requires 18–32 VDC (at 50mA per channel) from the external power supply.

The DL205 AC bases have a built-in 24VDC power supply that provide up to 300mA of current. This can be used instead of a separate supply. Check the power budget to be safe.

It is desirable in some situations to power the transmitters separately in a location remote from the PLC. This will work as long as the transmitter supply meets the current requirements, and the transmitter's negative (-) side and the module supply's negative (-) side are connected together.



WARNING: If the internal 24VDC base power is used, be sure to calculate the power budget. Exceeding the power budget can cause unpredictable system operation that can lead to a risk of personal injury or equipment damage.

Wiring Diagram

The F2-02DAS-1 module has a removable connector which helps to simplify wiring. Squeeze the top and bottom retaining clips and gently pull the connector from the module. Use the following diagram to connect the field wiring.

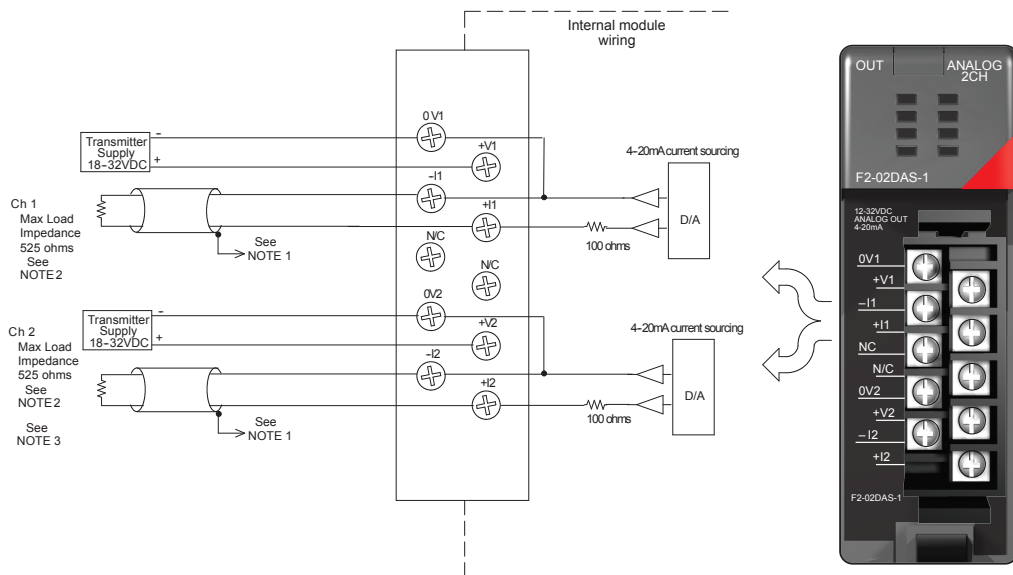

NOTE 1: Shields should be connected to the 0V terminal of the module or 0V of the power supply.

NOTE 2: Loads must be within the compliance voltage.

NOTE 3: For non-isolated outputs, connect (0V1 & 0V2) together and connect (+V1 & +V2) together

Module Operation

Before beginning to write the control program, it is important to take a few minutes to understand how the module processes the analog signals.

Channel Update Sequence (Multiplexing) for a D2-230 CPU

If a multiplexing program is being used, only one channel of data can be sent to the output module on each scan. The module refreshes both field devices on each scan, but new data can only be obtained from the CPU at the rate of one channel per scan. Since there are two channels, it can take two scans to update both channels. However, if only one channel is being used, that channel will be updated on every scan. The multiplexing method can also be used for the D2-240, D2-250-1, D2-260 and D2-262 CPUs.

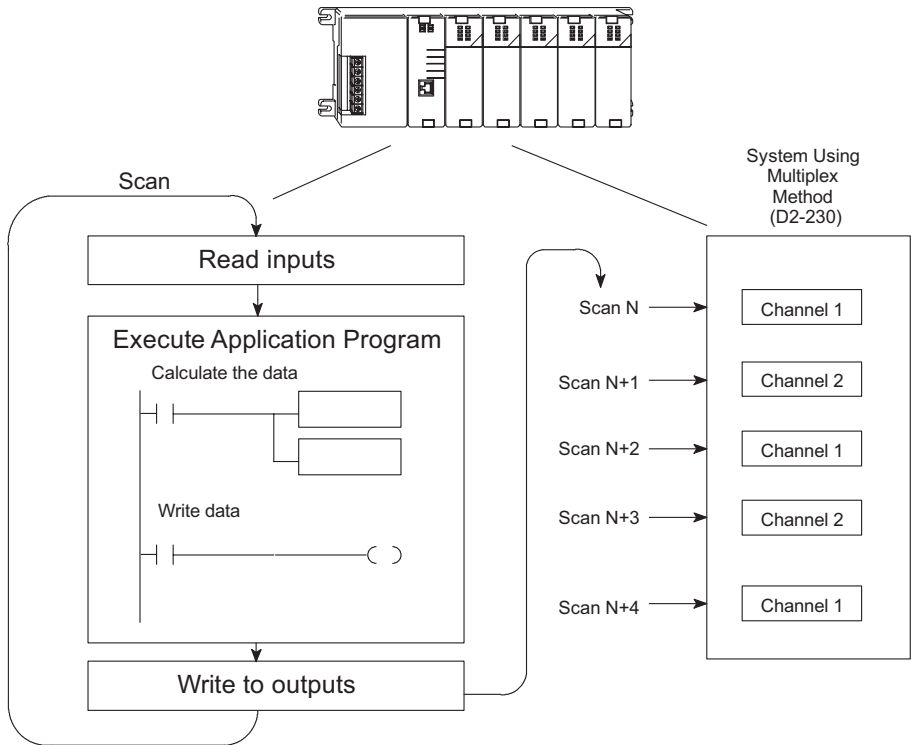

Channel Update Sequence (Pointer Method) for D2-240, D2-250-1, D2-260 and D2-262 CPUs

If either a D2-240, D2-250-1, D2-260 or D2-262 CPU is used with the pointer method, all channels can be updated on every scan. This is because the three CPUs support special V-memory locations that are used to manage the data transfer. This is discussed in more detail in the section on Writing the Control Program later in this chapter.

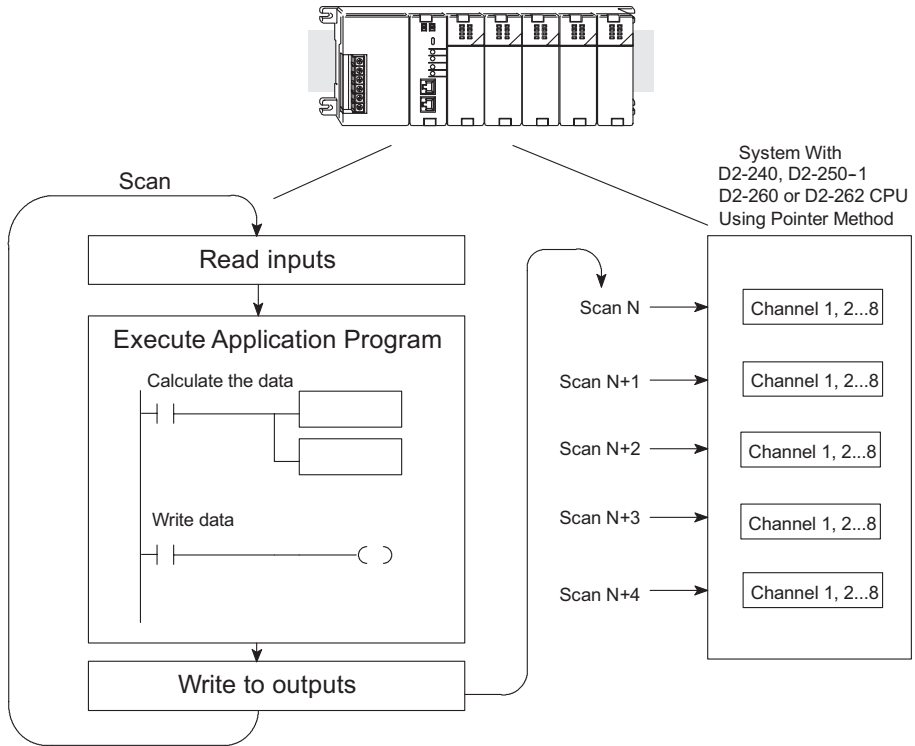

Understanding the Output Assignments

Remember that the F2-02DAS-1 module appears to the CPU as a 32-point discrete output module. These points provide the data value and an indication of which channel to update. Note, if either a D2-240, D2-250-1, D2-260 or D2-262 CPU is being used, these bits may never have to be used, but it may be an aid to help understand the data format.

Since all output points are automatically mapped into V-memory, the location of the data word that will be assigned to the module can simply be determined.

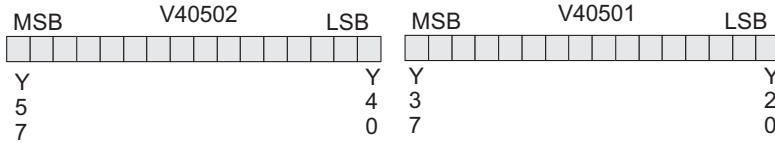
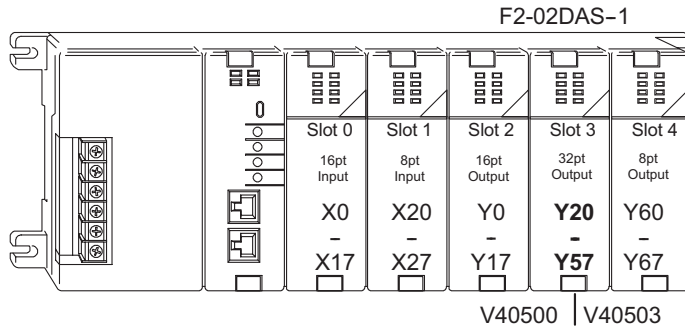

The individual bits in this data word location, represents specific information about the analog signal.

Channel Select Outputs

Two of the outputs select the active channel. Remember, the V-memory bits are mapped directly to discrete outputs. Turning a bit OFF selects a channel. By controlling these outputs, the channel to be updated is selected.

Y41	Y40	Channel
On	Off	1
Off	On	2
Off	Off	1 & 2 (same data to both channels)
On	On	None (both channels hold current values)

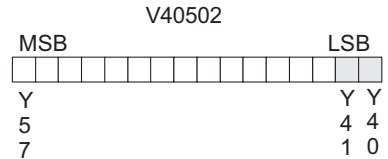

= channel select outputs

Analog Data Bits

The first sixteen bits represent the analog data in binary format.

Bit	Value	Bit	Value
0	1	8	256
1	2	9	512
2	4	10	1024
3	8	11	2048
4	16	12	4096
5	32	13	8192
6	64	14	16384
7	128	15	32768

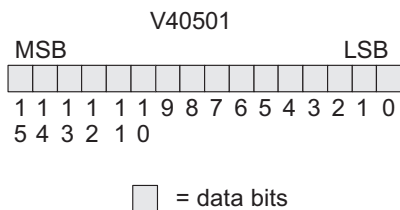

Module Resolution

Since the module has 16-bit resolution, the analog signal is converted into 65536 counts ranging from 0-65535 (2¹⁶). For example, send a 0 to get a 4mA signal, and 65535 to get a 20mA signal. This is equivalent to a binary value of 0000 0000 0000 0000 to 1111 1111 1111 1111, or 0000 to FFFF hexadecimal. The diagram below shows how this relates to the signal range.

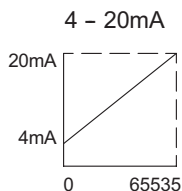

$$\text{Resolution} = \frac{H - L}{65535}$$

H = High limit of the signal range
 L = Low limit of the signal range

$$16\text{mA} / 65535 = 0.2241 \mu\text{A per count}$$

Each count can also be expressed in terms of the signal level by using the equation shown.

Writing the Control Program

Calculating the Digital Value

The control program must calculate the digital value that is sent to the analog output. Several methods can be used to do this, but the best method is to convert the values to engineering units. This is accomplished by using the formula shown.

Adjustments may need to be made to the formula depending on the scale of the engineering units.

$$A = U \frac{65535}{H - L}$$

A = Analog Value (0 – 65535)

U = Engineering Units

H = High limit of the engineering unit range

L = Low limit of the engineering unit range

Consider the following example which controls pressure from 0.0–99.9 PSI. Using the formula will calculate the digital value to be sent to the analog output. The example shows the conversion required to yield 49.4 PSI. The multiplier of 10 is because the decimal portion of 49.4 cannot be loaded in the program, so it is shifted right one decimal place to make a usable value of 494.

$$A = 10U \frac{65535}{10(H - L)}$$

$$A = 494 \frac{65535}{1000 - 0}$$

$$A = 32374$$

Refer to the example on the next page to write the conversion program.

Engineering Units Conversion

This example program shows how to write the program to perform the engineering unit conversion to output data formats 0–65535 when using a D2-250-1 CPU. This example assumes that a BCD value has been stored in V2300 for channel 1.

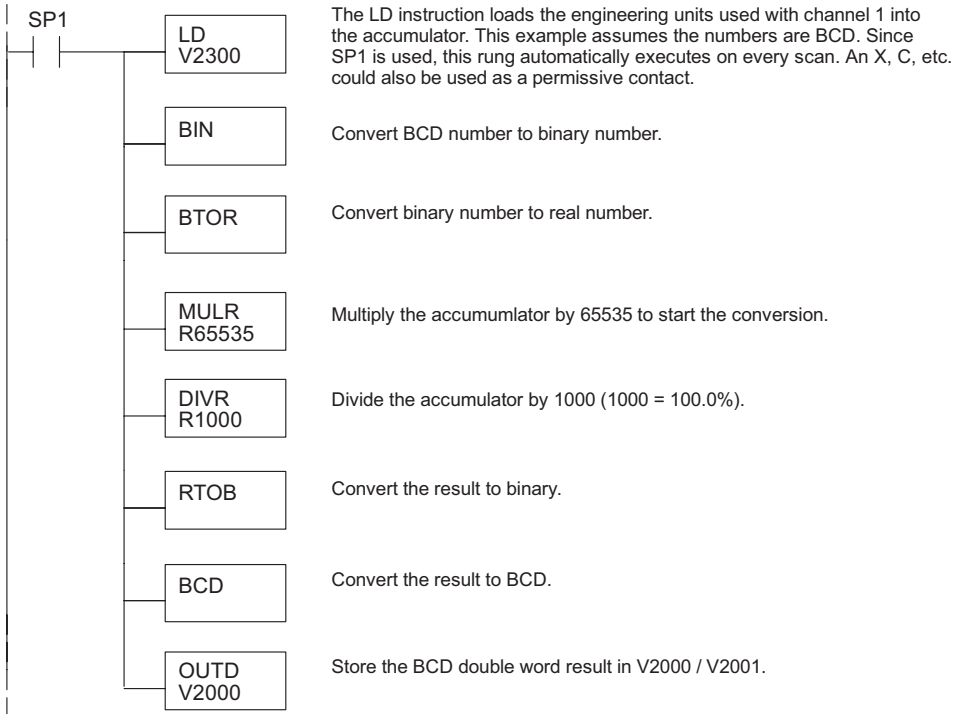

Writing Values: Pointer Method and Multiplexing

Two methods are used to read data values:

- Pointer method
- Multiplexing

The multiplexing method must be used with a D2-230 CPU. The multiplexing method must also be used with remote I/O modules (the pointer method will not work). Either method can be used with the D2-240, D2-250-1, D2-260 and D2-262 CPUs, but for ease of programming it is highly recommended to use the pointer method.

Pointer Method for D2-240, D2-250-1, D2-260 and D2-262 CPUs

The D2-240, D2-250-1, D2-260 and D2-262 CPUs have special V-memory locations assigned to each base slot that will greatly simplify the programming requirements.

These V-memory locations allow you to:

- Specify the data format
- Specify the number of channels to scan
- Specify the location of the data that will be written to the module



NOTE: D2-240 CPUs with firmware release version 3.0 or later and D2-250 CPUs with firmware release version 1.33 or later support this method.

The following example program shows how to setup these locations. Place this rung anywhere in the ladder program, or in the initial stage if stage programming instructions are being used. In this example V2000 and V2002 are used to store the calculated values, the analog module is installed in slot 3. Be sure to use the V-memory locations for the module placement. The pointer method automatically converts values to binary.

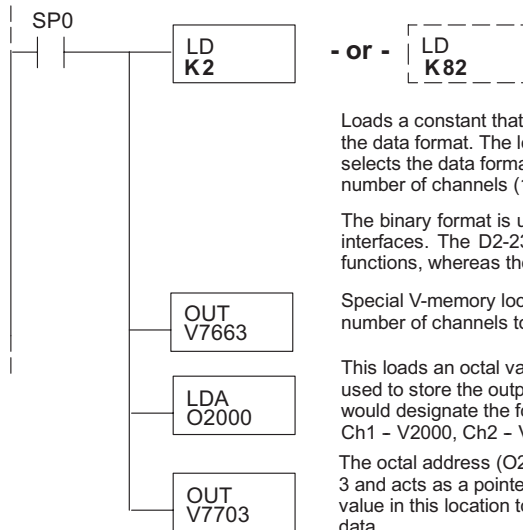

Loads a constant that specifies the number of channels to scan and the data format. The lower byte, most significant nibble (MSN) selects the data format (i.e. 0=BCD, 8=Binary), the LSN selects the number of channels (1 or 2).

The binary format is used for displaying data on some operator interfaces. The D2-230/ D2-240 CPUs do not support binary math functions, whereas the D2-250-1, D2-260, and D2-262 do.

Special V-memory location assigned to slot 3 that contains the number of channels to scan.

This loads an octal value for the first V-memory location that will be used to store the output data. For example, the O2000 entered here would designate the following addresses.
Ch1 - V2000, Ch2 - V2002

The octal address (O2000) is stored here. V7703 is assigned to slot 3 and acts as a pointer, which means the CPU will use the octal value in this location to determine exactly where to store the output data.

The following tables show the special V-memory locations used by the D2-240, D2-250-1, D2-260 and D2-262 for the CPU base and local expansion base I/O slots. Slot 0 (zero) is the module next to the CPU or D2-CM module. Slot 1 is the module two places from the CPU or D2-CM, and so on. Remember, the CPU only examines the pointer values at these locations after a mode transition. Also, if the D2-230 (multiplexing) method is used, verify that these addresses in the CPU are 0 (zero).

The table below applies to the D2-240, D2-250-1, D2-260 and D2-262 CPU base.

CPU Base: Analog Output Module Slot-Dependent V-memory Locations								
Slot	0	1	2	3	4	5	6	7
No. of Channels	V7660	V7661	V7662	V7663	V7664	V7665	V7666	V7667
Storage Pointer	V7700	V7701	V7702	V7703	V7704	V7705	V7706	V7707

The table below applies to the D2-250-1, D2-260 or a D2-262 CPU base 1.

Expansion Base D2-CM #1: Analog Output Module Slot-Dependent V-memory Locations								
Slot	0	1	2	3	4	5	6	7
No. of Channels	V36000	V36001	V36002	V36003	V36004	V36005	V36006	V36007
Storage Pointer	V36020	V36021	V36022	V36023	V36024	V36025	V36026	V36027

The table below applies to the D2-250-1, D2-260 or a D2-262 CPU base 2.

Expansion Base D2-CM #2: Analog Output Module Slot-Dependent V-memory Locations								
Slot	0	1	2	3	4	5	6	7
No. of Channels	V36100	V36101	V36102	V36103	V36104	V36105	V36106	V36107
Storage Pointer	V36120	V36121	V36122	V36123	V36124	V36125	V36126	V36127

The table below applies to the D2-260 and D2-262 CPU base 3.

Expansion Base D2-CM #3: Analog Output Module Slot-Dependent V-memory Locations								
Slot	0	1	2	3	4	5	6	7
No. of Channels	V36200	V36201	V36202	V36203	V36204	V36205	V36206	V36207
Storage Pointer	V36220	V36221	V36222	V36223	V36224	V36225	V36226	V36227

The table below applies to the D2-260 and D2-262 CPU base 4.

Expansion Base D2-CM #4: Analog Output Module Slot-Dependent V-memory Locations								
Slot	0	1	2	3	4	5	6	7
No. of Channels	V36300	V36301	V36302	V36303	V36304	V36305	V36306	V36307
Storage Pointer	V36320	V36321	V36322	V36323	V36324	V36325	V36326	V36327

Write Data Example (Multiplexing)

Since all channels are multiplexed into a single data word, the control program can be setup to determine which channel to write the data to. Since the module appears as Y output points to the CPU, it is simple to use the channel selection outputs to determine which channel to update.

Note, this example is for a module installed in slot 3, as shown in the previous examples. The addresses used would be different if the module was used in a different slot. These rungs can be placed anywhere in the program or if stage programming is being used, place them in a stage that is always active.

This example is a two-channel multiplexer that updates each channel on alternate scans. Relay SP7 is a special relay that is on for one scan, then off for one scan. This multiplexing example can be used with all of the DL205 CPUs.



NOTE: Binary data must be sent to the output module. If the data is already in binary format, do not use the BIN instruction shown in this example.

Load data into the accumulator.

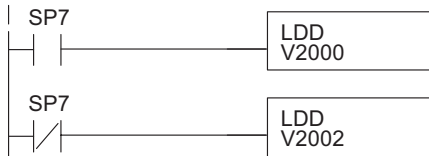

Loads the data for channel 1 into the accumulator.
Note: Use LD if using binary, and use LDD if using BCD.

Loads the data for channel 2 into the accumulator.
Note: Use LD if using binary, and use LDD if using BCD.

Send data to V-memory assigned to the module.

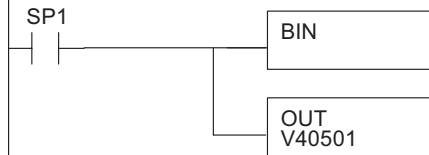

Convert the data to binary (you must omit this step if you have converted the data elsewhere). SP1 is always on.

The OUT instruction sends the data to the module. Our example starts with V40501, but the actual value depends on the location of the module in your application.

Select the channel to update.

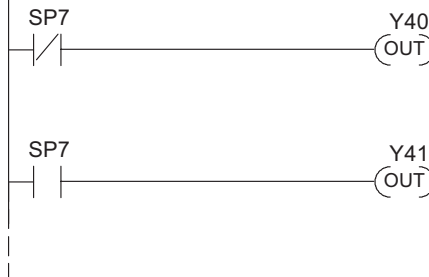

Selects channel 2 for update when Y41 is OFF (Y40-ON deselects channel 1). Note, Y40 and Y41 are used as in the previous examples. If the module was installed in a different I/O arrangement the addresses would be different.

Selects channel 1 for update when Y41 is OFF (Y41-ON deselects channel 2). Note, Y40 and Y41 are used as in the previous examples. If the module was installed in a different I/O arrangement the addresses would be different.

Write Data to One Channel

If only one channel is being used, or if the updates are to be controlled separately, the following program can be used.

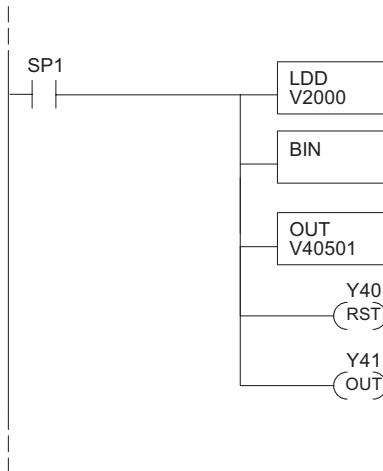

The LD instruction loads the data into the accumulator. Since SP1 is used, this rung automatically executes on every scan. X, C, etc. can also be used as permissive contacts.

Note: Use LD if using binary, and use LDD if using BCD.

The BIN instruction converts the accumulator data to binary (you must omit this step if you have already converted the data elsewhere).

The OUT instruction sends the data to the module. Our example starts with V40501, but the actual value depends on the location of the module in your application.

Y40-OFF selects channel 1 for updating.

Y41-ON deselected channel 2 (do not update).

Write the same Data to Both Channels

If both channel select outputs are off, then both channels will be updated with the same data.

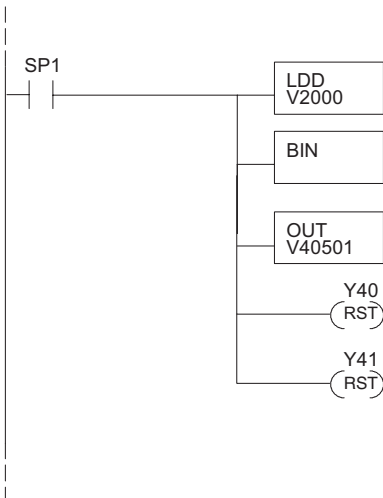

The LD instruction loads the data into the accumulator. Since SP1 is used, this rung automatically executes on every scan. The X, C, etc. can also be used as permissive contacts.

Note: Use LD if using binary, and use LDD if using BCD.

The BIN instruction converts the accumulator data to binary (you must omit this step if you have already converted the data elsewhere).

The OUT instruction sends the data to the module. Our example starts with V40501, but the actual value depends on the location of the module in your application.

Y40-OFF selects channel 1 for updating.

Y41-OFF selects channel 2 for updating.

Analog and Digital Value Conversions

It is sometimes useful to do quick conversions between the signal levels and the digital values. This can be helpful during startup and/or troubleshooting. The following table shows some formulas to help with the conversions.

Range	If the digital value is known	If the analog signal level is known.
4-20 mA	$A = \frac{16D + 4}{65535}$	$D = \frac{65535}{16} (A - 4)$

For example, if a 10mA signal level is needed, use the formula to the right to determine the digital value "D" to be stored in the V-memory location which is designated to store the data.

$D = \frac{65535}{16} (A - 4)$
$D = \frac{65535}{16} (10mA - 4)$
$D = (4095.94) (6)$
$D = 24575 (5FFFh)$

F2-02DAS-2, 0-5 V, 0-10 V, 2-CHANNEL ISOLATED ANALOG OUTPUT



In This Chapter...

Module Specifications	13-2
Setting the Module Jumpers	13-5
Connecting the Field Wiring.....	13-6
Module Operation	13-8
Writing the Control Program.....	13-12

Module Specifications

The F2-02DAS-2 Analog Output module provides several hardware features:

- Analog outputs are isolated from channel to channel and channel to PLC logic.
- The module has a removable terminal block so the module can be easily removed or changed without disconnecting the wiring.
- All channels can be updated in one scan if either a D2-240, a D2-250-1, a D2-260 or a D2-262 CPU is used in the PLC.
- Outputs are sourced through external loop supply.

Firmware Requirements:

- To use this module, D2-230 CPUs must have firmware version 2.7 or later.
- To use the pointer method for writing values, D2-240 CPUs require firmware version 3.0 or later.
- D2-250 CPUs require firmware version 1.33 or later.

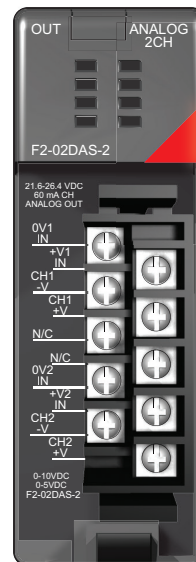

F2-02DAS-2

Chapter 13: F2-02DAS-2, 0-5V, 0-10V, 2-Channel Isolated Analog Output

The following tables provide the specifications for the F2-02DAS –2, Isolated Analog Output Module.

Output Specifications	
Number of Channels	2, isolated
Output Range	0–5 VDC, 0–10 VDC
Resolution	16 bit (1 in 65536)
Isolation Voltage	±750V continuous, channel to channel, channel to logic
Load Impedance	2kΩ minimum
Linearity Error (end to end)	±10 counts (±0.015% of full scale) maximum
Conversion Settling Time	3ms to 0.1% of full scale
Full Scale Calibration Error	±32 counts (±0.05%)
Offset Calibration Error	±13 counts (±0.02%)
Maximum Inaccuracy	±0.07% @ 25°C (77°F) ±0.18% 0–60°C (32–140°F)

General Specifications	
PLC Update Rate	1 channel per scan maximum (multiplexing) 2 channels per scan maximum (pointer – D2-240/D2-250-1/D2-260/ D2-262 CPUs)
Digital Outputs / Output Points Required	16 binary data bits, 2 channel ID bits; 32 point (Y) output module
Power Budget Requirement	60mA @ 5VDC (supplied by the base)
External Power Supply	21.6–26.4 VDC @ 60mA
Operating Temperature	0–60°C (32–140°F)
Storage Temperature	–20°C to 70°C (–4°F to 158°F)
Relative Humidity	5–95% (non-condensing)
Environmental Air	No corrosive gases permitted
Vibration	MIL STD 810C 514.2
Shock	MIL STD 810C 516.2
Noise Immunity	NEMA ICS3-304

Analog Output Configuration Requirements

The F2-02DAS-2 analog output module requires 32 discrete output points. The module can be installed in any slot of a DL205 system, but the available power budget and discrete I/O points are the limiting factors. Check the DL205 PLC User Manual for the particular model of CPU and I/O base being used for information regarding power budget and number of local, local expansion or remote I/O points.

Special Placement Requirements (D2-230 and Remote I/O Bases)

It is important to examine the configuration if a D2-230 CPU is being used in a multiplexing program. As can be seen in the section on Writing the Control Program, V-memory locations are used to hold the analog data that will be written to the output. If the module is placed in a slot so that the output points do not start on a V-memory boundary, the program instructions will not be able to access the data. This also applies when placing this module in a remote base using a D2-RSSS in the CPU slot.

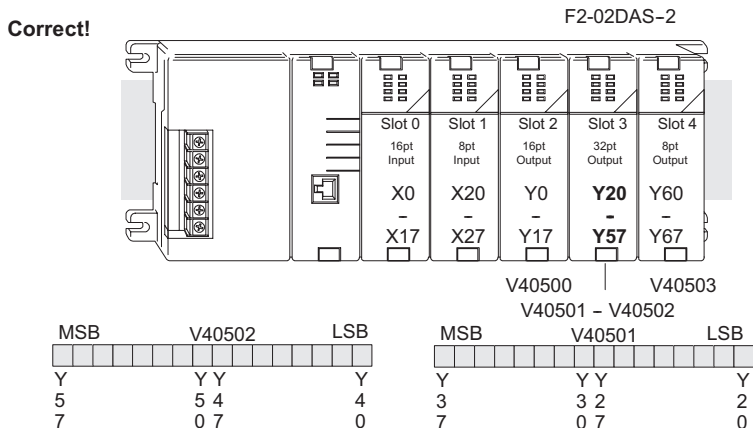

Data can be written correctly because the output points start on a V-memory boundary address as seen in the table above.

To use the V-memory references required for a D2-230 CPU, the first output address assigned to the module must be one of the following Y locations. The table also shows the V-memory addresses that correspond to these Y locations.

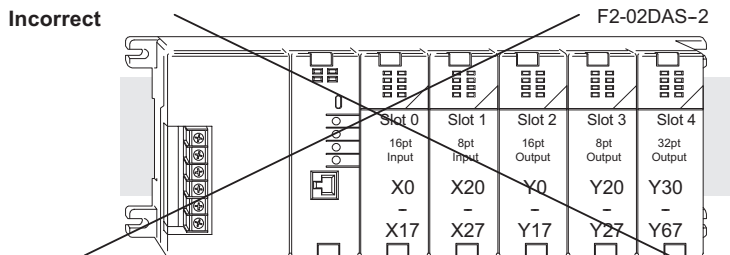

Data is split over three locations, so instructions cannot access data from a D2-230 (or when module is placed in a remote base).

MSB										V40503										LSB										MSB										V40502										LSB										MSB										V40501										LSB									
Y										Y	Y								Y	Y										Y	Y								Y	Y	Y								Y																																								
7										6	5								4	4	3									3									2	3	2								2																																								
7										7									0	7										7									0	7									0																																								

Y	Y0	Y20	Y40	Y60	Y100	Y120	Y140	Y160
V	V40500	V40501	V40502	V40503	V40504	V40505	V40506	V40507

Setting the Module Jumpers

The F2-02DAS-2 Analog Output module uses jumpers for selecting the voltage range for each channel. The range of each channel can be independently set. The available operating ranges are 0–5V and 0–10V.

There is one jumper for each channel. Install or remove these jumpers to select the desired range. Unused jumpers can be stored on a single pin so they will not get lost. The module comes from the factory set for the 0–5V range.



NOTE: Be sure to set the range jumpers properly for the module will not function properly if the range jumpers are not set for the desired voltage range.

The following diagrams show the jumper locations. The newer models have a single circuit board design. Refer to the top diagram if one of these modules is used in your system. The older modules have a two circuit board design. The range jumpers for this module is located on the top circuit board. Refer to the lower diagram.

Single Circuit Board Design

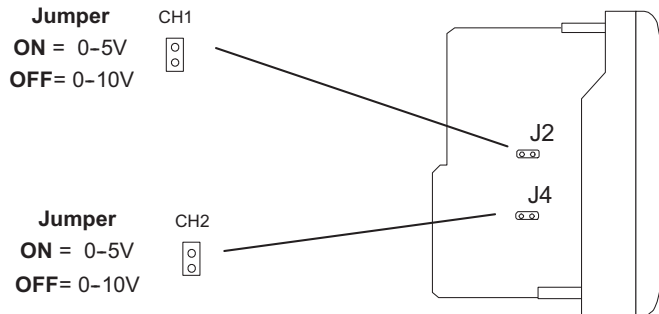

Two Circuit Board Design

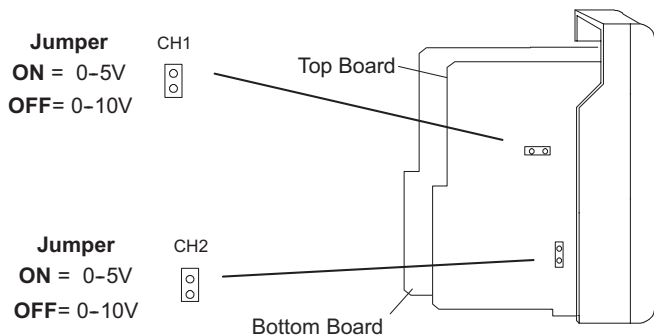

Connecting the Field Wiring

Wiring Guidelines

Your company may have guidelines for wiring and cable installation. If so, check the guidelines before beginning the installation. Here are some general things to consider:

- Use the shortest wiring route whenever possible.
- Use shielded wiring and ground the shield at the transmitter source. Do not ground the shield at both the module and the source.
- Do not run the signal wiring next to large motors, high current switches, or transformers. This may cause noise problems.
- Route the wiring through an approved cable housing to minimize the risk of accidental damage. Check local and national codes to choose the correct method for your application.

Transmitter Power Supply Requirements

The F2-02DAS-2 module requires at least one field-side power supply. Separate power sources should be used to maintain the channel to channel isolation. The F2-02DAS-2 module requires 21.6–26.4 VDC (at 60mA per channel) from the external power supply.

The DL205 AC bases have a built-in 24VDC power supply that provide up to 300mA of current. This can be used instead of a separate supply. Check the power budget to be safe.

It is desirable in some situations to power the transmitters separately in a location remote from the PLC. This will work as long as the transmitter supply meets the current requirements, and the transmitter's negative (-) side and the module supply's negative (-) side are connected together.



WARNING: If the internal 24VDC base power is used, be sure to calculate the power budget. Exceeding the power budget can cause unpredictable system operation that can lead to a risk of personal injury or equipment damage.

Wiring Diagram

The F2-02DAS-2 module has a removable connector which helps to simplify wiring. Squeeze the top and bottom retaining clips and gently pull the connector from the module. Use the following diagram to connect the field wiring.

NOTE 1: Shields should be connected to the 0V terminal of the module.
 NOTE 2: Loads must be within the compliance voltage.
 NOTE 3: For non-isolated outputs, connect 0V1 to 0V2.

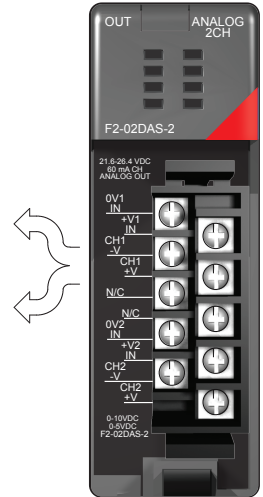
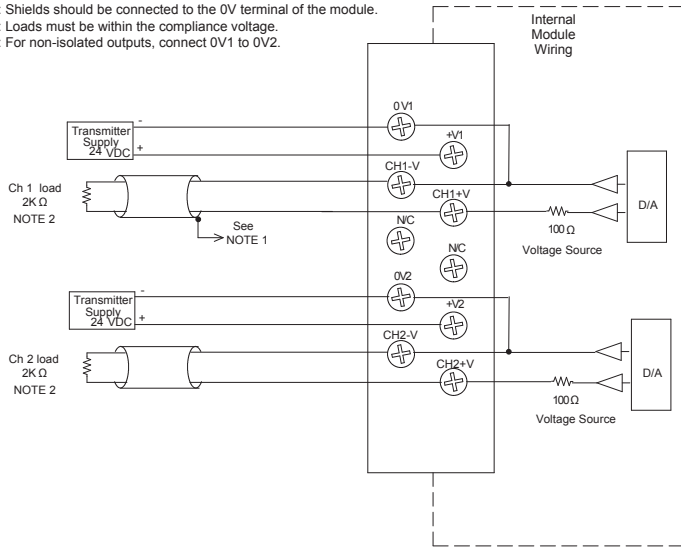

Module Operation

Before beginning to write the control program, it is important to take a few minutes to understand how the module processes the analog signals.

Channel Update Sequence (Multiplexing) for a D2-230 CPU

If a multiplexing program is being used, only one channel of data can be sent to the output module on each scan. The module refreshes both field devices on each scan, but new data can only be obtained from the CPU at the rate of one channel per scan. Since there are two channels, it can take two scans to update both channels. However, if only one channel is being used, that channel will be updated on every scan. The multiplexing method can also be used for the D2-240, D2-250-1, D2-260 and D2-262 CPUs.

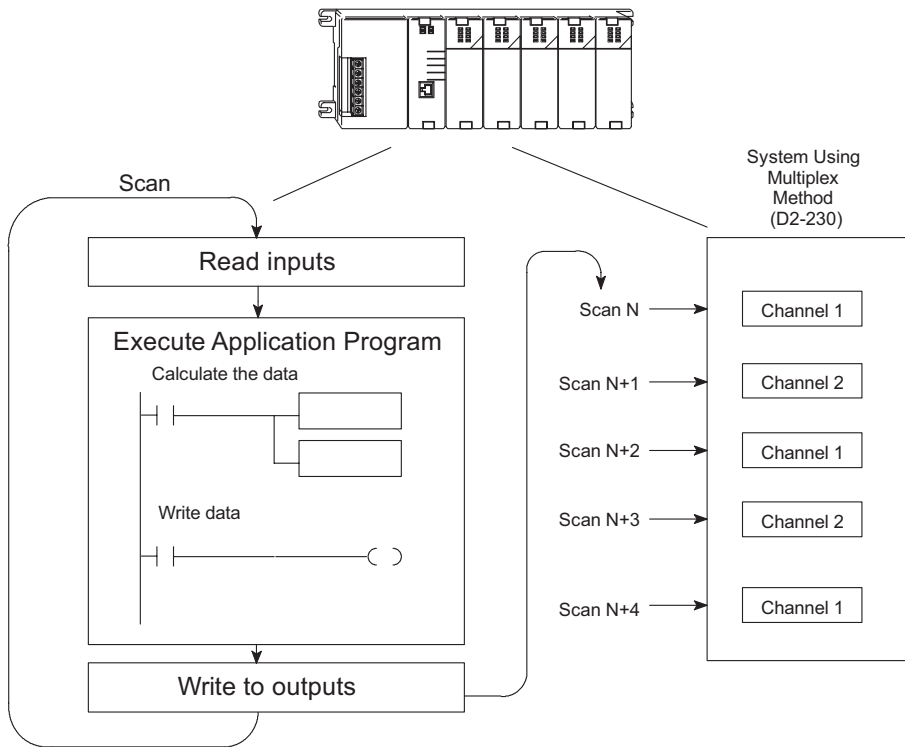

Channel Update Sequence (Pointer Method) for D2-240, D2-250-1, D2-260 and D2-262 CPUs

If either a D2-240, D2-250-1, D2-260 or a D2-262 CPU is used with the pointer method, all channels can be updated on every scan. This is because the three CPUs support special V-memory locations that are used to manage the data transfer. This is discussed in more detail in the section on Writing the Control Program later in this chapter.

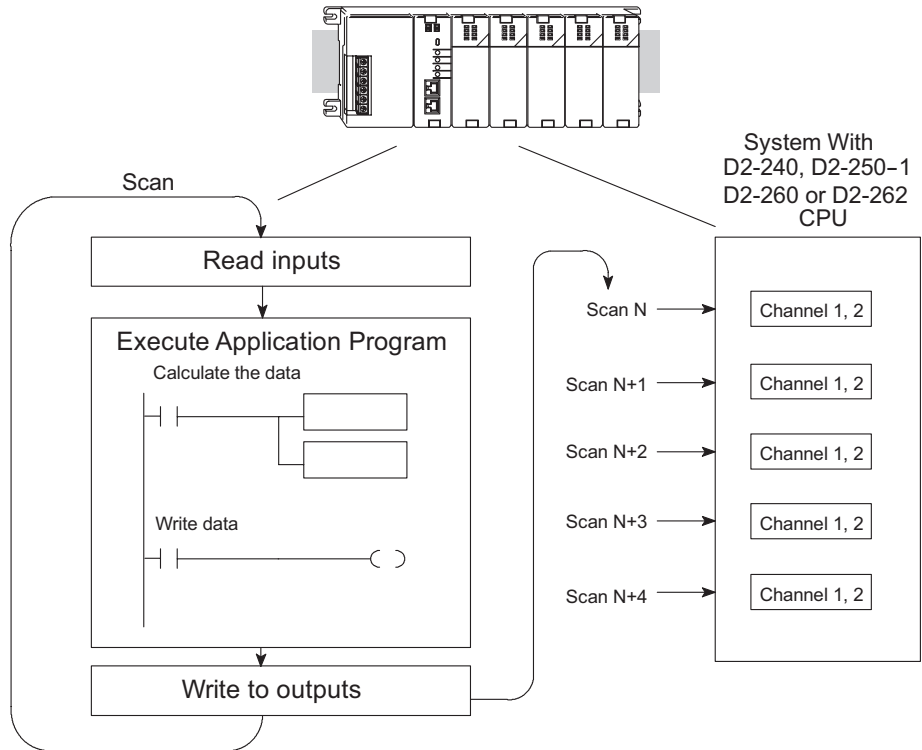

Understanding the Output Assignments

Remember that the F2-02DAS-2 module appears to the CPU as a 32-point discrete output module. These points provide the data value and an indication of which channel to update. Note, if either a D2-240, D2-250, D2-260 or D2-262 CPU is being used, these bits may never have to be used, but it may be an aid to help understand the data format.

Since all output points are automatically mapped into V-memory, the location of the data word that will be assigned to the module can simply be determined.

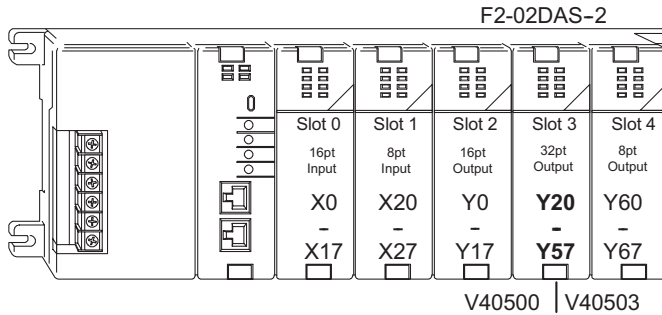

The individual bits in this data word location, represents specific information about the analog signal.

Channel Select Outputs

Two of the outputs select the active channel. Remember, the V-memory bits are mapped directly to discrete outputs. Turning a bit OFF selects a channel. By controlling these outputs, the channel to be updated can be selected.

Y41	Y40	Channel
On	Off	1
Off	On	2
Off	Off	1 & 2 (same data to both channels)
On	On	None (both channels hold current values)

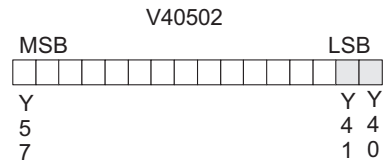

= channel select outputs

Analog Data Bits

The first sixteen bits represent the analog data in binary format.

Bit	Value	Bit	Value
0	1	8	256
1	2	9	512
2	4	10	1024
3	8	11	2048
4	16	12	4096
5	32	13	8192
6	64	14	16384
7	128	15	32768

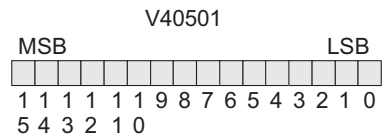

= data bits

Module Resolution

Since the module has 16-bit resolution, the analog signal is converted into 65536 counts ranging from 0–65535 (2¹⁶). For example, send a 0 to get a 0V signal, and 65535 to get a 10V signal. This is equivalent to a binary value of 0000 0000 0000 0000 to 1111 1111 1111 1111, or 0000 to FFFF hexadecimal. The diagram shows how this relates to the signal range.

Each count can also be expressed in terms of the signal level by using the equation shown.

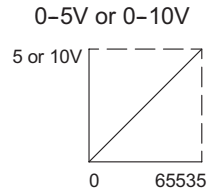

$$\text{Resolution} = \frac{H - L}{65535}$$

H = High limit of the signal range

L = Low limit of the signal range

Writing the Control Program

Calculating the Digital Value

The control program must calculate the digital value that is sent to the analog output. Several methods can be used to do this, but the best method is to convert the values to engineering units. This is accomplished by using the formula shown.

Adjustments may need to be made to the formula depending on the scale of the engineering units.

$$A = U \frac{65535}{H-L}$$

A = Analog Value (0-65535)

U = Engineering Units

H = High limit of the engineering unit range

L = Low limit of the engineering unit range

Consider the following example which controls pressure from 0.0–99.9 PSI. Using the formula will calculate the digital value to be sent to the analog output. The example shows the conversion required to yield 49.4 PSI. The multiplier of 10 is because the decimal portion of 49.4 cannot be loaded in the program, so it is shifted right one decimal place to make a usable value of 494.

$$A = 10U \frac{65535}{10(H-L)} \qquad A = 494 \frac{65535}{1000-0} \qquad A = 32374$$

Refer to the example on the next page to write the conversion program.

Engineering Units Conversion

This example program shows how to write the program to perform the engineering unit conversion to output data formats 0–65535 when using a D2-250 CPU. This example assumes that a BCD value has been stored in V2300 for channel 1.

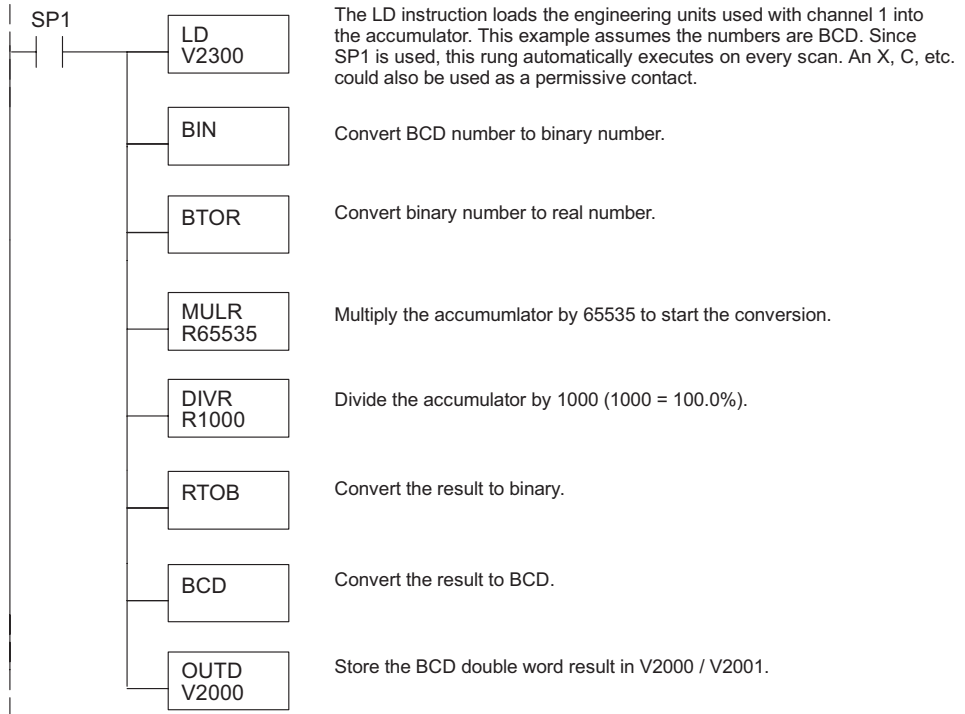

Writing Values: Pointer Method and Multiplexing

There are two methods of reading values:

- Pointer method
- Multiplexing

The multiplexing method must be used with a D2-230 CPU. The multiplexing method must also be used with remote I/O modules (the pointer method will not work). Either method can be used with the D2-240, D2-250-1, D2-260 and D2-262 CPUs, but for ease of programming it is highly recommended to use the pointer method.

Pointer Method for the D2-240, D2-250-1, D2-260 and D2-262 CPUs

The D2-240, D2-250-1, D2-260 and D2-262 CPUs have special V-memory locations assigned to each base slot that will greatly simplify the programming requirements.

These V-memory locations allow you to:

- Specify the data format
- Specify the number of channels to scan
- Specify the location of the data that will be written to the modules.



NOTE: D2-240 CPUs with firmware release version 3.0 or later and D2-250 CPUs with firmware release version 1.33 or later support this method.

The following example program shows how to setup these locations. Place this rung anywhere in the ladder program, or in the initial stage if stage programming instructions are being used. In this example V2000 and V2002 are used to store the calculated values, the analog module is installed in slot 3. Be sure to use the V-memory locations for the module placement. The pointer method automatically converts values to binary.

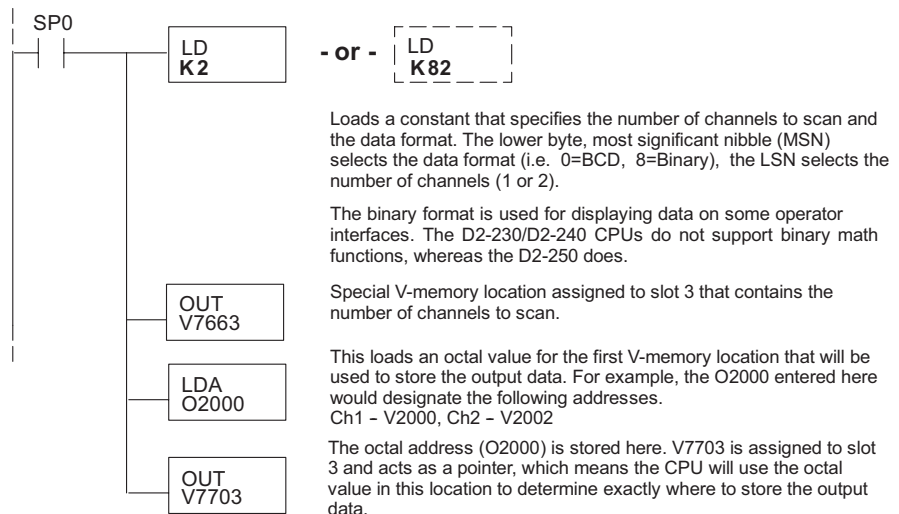

Chapter 13: F2-02DAS-2, 0-5V, 0-10V, 2-Channel Isolated Analog Output

The following tables show the special V-memory locations used by the D2-240, D2-250-1 and D2-260 and D2-262 for the CPU base and local expansion base I/O slots. Slot 0 (zero) is the module next to the CPU or D2-CM module. Slot 1 is the module two places from the CPU or D2-CM, and so on. Remember, the CPU only examines the pointer values at these locations after a mode transition. Also, if the D2-230 (multiplexing) method is used, verify that these addresses in the CPU are 0 (zero).

The table below applies to the D2-240, D2-250-1, D2-260 and D2-262 CPU base.

CPU Base: Analog Output Module Slot-Dependent V-memory Locations								
Slot	0	1	2	3	4	5	6	7
No. of Channels	V7660	V7661	V7662	V7663	V7664	V7665	V7666	V7667
Storage Pointer	V7700	V7701	V7702	V7703	V7704	V7705	V7706	V7707

The table below applies to the D2-250-1, D2-260 or D2-262 CPU base 1.

Expansion Base D2-CM #1: Analog Output Module Slot-Dependent V-memory Locations								
Slot	0	1	2	3	4	5	6	7
No. of Channels	V36000	V36001	V36002	V36003	V36004	V36005	V36006	V36007
Storage Pointer	V36020	V36021	V36022	V36023	V36024	V36025	V36026	V36027

The table below applies to the D2-250-1, D2-260 or D2-262 CPU base 2.

Expansion Base D2-CM #2: Analog Output Module Slot-Dependent V-memory Locations								
Slot	0	1	2	3	4	5	6	7
No. of Channels	V36100	V36101	V36102	V36103	V36104	V36105	V36106	V36107
Storage Pointer	V36120	V36121	V36122	V36123	V36124	V36125	V36126	V36127

The table below applies to the D2-260 and D2-262 CPU base 3.

Expansion Base D2-CM #3: Analog Output Module Slot-Dependent V-memory Locations								
Slot	0	1	2	3	4	5	6	7
No. of Channels	V36200	V36201	V36202	V36203	V36204	V36205	V36206	V36207
Storage Pointer	V36220	V36221	V36222	V36223	V36224	V36225	V36226	V36227

The table below applies to the D2-260 and D2-262 CPU base 4.

Expansion Base D2-CM #4: Analog Output Module Slot-Dependent V-memory Locations								
Slot	0	1	2	3	4	5	6	7
No. of Channels	V36300	V36301	V36302	V36303	V36304	V36305	V36306	V36307
Storage Pointer	V36320	V36321	V36322	V36323	V36324	V36325	V36326	V36327

Write Data Example (Multiplexing)

Since all channels are multiplexed into a single data word, the control program can be setup to determine which channel to write the data to. Since the module appears as Y output points to the CPU, it is simple to use the channel selection outputs to determine which channel to update.

Note, this example is for a module installed in slot 3, as shown in the previous examples. The addresses used would be different if the module was used in a different slot. These rungs can be placed anywhere in the program or if stage programming is being used, place them in a stage that is always active.

This example is a two-channel multiplexer that updates each channel on alternate scans. Relay SP7 is a special relay that is on for one scan, then off for one scan. This multiplexing example can be used with all of the DL205 CPUs.



NOTE: Binary data must be sent to the output module. If the data is already in binary format, do not use the BIN instruction shown in this example.

Load data into the accumulator.

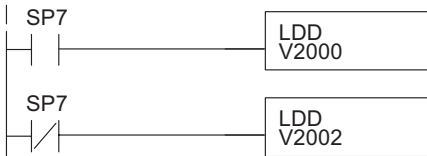

Loads the data for channel 1 into the accumulator.

Note: Use LD if using binary, and use LDD if using BCD.

Loads the data for channel 2 into the accumulator.

Note: Use LD if using binary, and use LDD if using BCD.

Send data to V-memory assigned to the module.

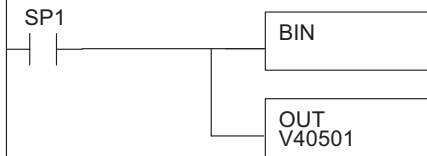

Convert the data to binary (you must omit this step if you have converted the data elsewhere). SP1 is always on.

The OUT instruction sends the data to the module. Our example starts with V40501, but the actual value depends on the location of the module in your application.

Select the channel to update.

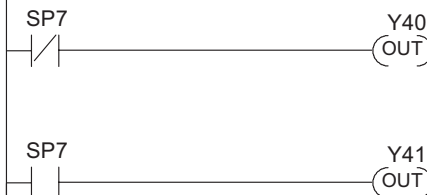

Selects channel 2 for update when Y41 is OFF (Y40-ON deselects channel 1). Note, Y40 and Y41 are used as in the previous examples. If the module was installed in a different I/O arrangement the addresses would be different.

Selects channel 1 for update when Y41 is OFF (Y41-ON deselects channel 2). Note, Y40 and Y41 are used as in the previous examples. If the module was installed in a different I/O arrangement the addresses would be different.

Write Data to One Channel

If only one channel is being used, or if the updates are to be controlled separately, the following program can be used.

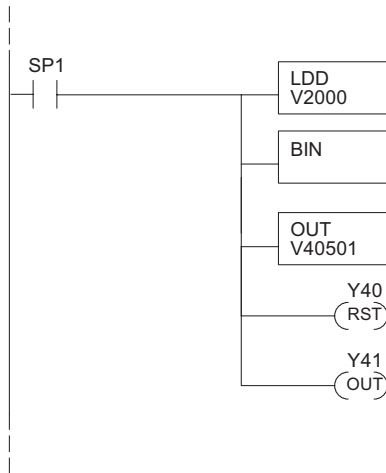

The LD instruction loads the data into the accumulator. Since SP1 is used, this rung automatically executes on every scan. X, C, etc. can also be used as permissive contacts.

Note: Use LD if using binary, and use LDD if using BCD.

The BIN instruction converts the accumulator data to binary (you must omit this step if you have already converted the data elsewhere).

The OUT instruction sends the data to the module. Our example starts with V40501, but the actual value depends on the location of the module in your application.

Y40-OFF selects channel 1 for updating.

Y41-ON deselected channel 2 (do not update).

Write the same Data to Both Channels

If both channel select outputs are off, then both channels will be updated with the same data.

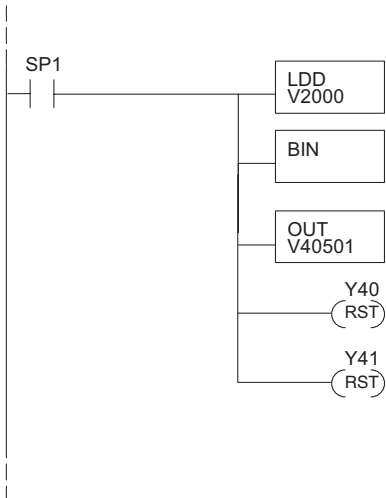

The LD instruction loads the data into the accumulator. Since SP1 is used, this rung automatically executes on every scan. The X, C, etc. can also be used as permissive contacts.

Note: Use LD if using binary, and use LDD if using BCD.

The BIN instruction converts the accumulator data to binary (you must omit this step if you have already converted the data elsewhere).

The OUT instruction sends the data to the module. Our example starts with V40501, but the actual value depends on the location of the module in your application.

Y40-OFF selects channel 1 for updating.

Y41-OFF selects channel 2 for updating.

Analog and Digital Value Conversions

It is sometimes useful to do quick conversions between the signal levels and the digital values. This can be helpful during startup and/or troubleshooting. The following table shows some formulas to help with the conversions.

Range	If the digital value is known	If the analog signal level is known.
0-5 VDC	$A = \frac{5D}{65535}$	$D = \frac{65535}{5} A$
0-10 VDC	$A = \frac{10D}{65535}$	$D = \frac{65535}{10} A$

For example, if a 4V signal is needed, use the formula to the right to determine the digital value to be stored in the V-memory location which is designated to store the data.

$$D = \frac{65535}{5} A$$

$$D = \frac{65535}{5} (4)$$

$$D = (13107) (4)$$

$$D = 52428 (CCCC_1)$$

F2-4AD2DA 4-CH. IN / 2-CH. OUT ANALOG COMBINATION



In This Chapter...

Module Specifications	14-2
Connecting the Field Wiring.....	14-5
Module Operation	14-8
Writing the Control Program.....	14-13

Module Specifications

The F2-4AD2DA analog current input/output module provides several hardware features:

- On-board 250 ohm, 1/2 watt precision resistors provide substantial over-current-protection for 4–20 mA current loops.
- Analog inputs and outputs are optically isolated from the PLC logic.
- The module has a removable terminal block so the module can be easily removed or changed without disconnecting the wiring.
- All input and output channels can be updated in one scan if either a D2-240, a D2-250-1, a D2-260 or a D2-262 CPU is used in the PLC.
- On-board active analog filtering and RISC-like microcontroller provide digital signal processing to maintain precision analog measurements in noisy environments.
- Low-power CMOS design requires less than 80mA from an external 24VDC power supply.

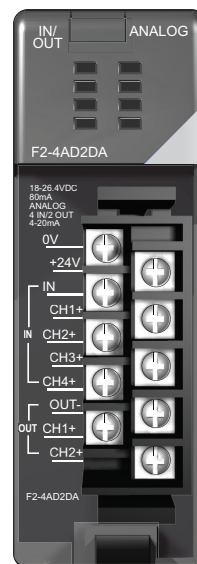

F2-4AD2DA

The following tables provide the specifications for the F2-4AD2DA analog current input/output module. Review these specifications to make sure the module meets your application requirements.

Input Specifications	
Number of Input Channels	4, single ended (one common)
Range	4–20 mA
Resolution	12 bit (1 in 4096)
Input Impedance	250Ω, ±0.1%, 1/2 W, 25ppm / °C current input resistance
Maximum Continuous Overload	±40mA, each current input
Input Stability	±1 count
Crosstalk	-70dB, 1 count maximum
Common Mode Rejection	-50dB @ 800Hz
Active Low-Pass Filter	-3dB @ 50Hz, 2 poles (-12dB per octave)
Step Response	10ms to 95%
Full Scale Calibration Error	±12 counts maximum, @ 20mA current input
Offset Calibration Error	±8 counts maximum, @ 4mA current input
Maximum Inaccuracy	±0.3% @ 25°C (77°F) ±0.45% @ 0–60°C (32–140°F)
Recommended External Fuse	0.032 A, series 217 fast-acting, current inputs

Output Specifications	
Number of Output Channels	2, single ended (one common)
Range	4–20 mA
Resolution	12 bit (1 in 4096)
Peak Withstanding Voltage	75VDC, current outputs
External Load Resistance	0Ω minimum, current outputs
Loop Supply Voltage Range	18–30 VDC, current outputs
Maximum Load / Power Supply	910Ω / 24V, 620Ω / 18V, 1200Ω / 30V, current outputs
Linearity Error (best fit)	±1 count (± 0.025% of full scale) maximum
Settling Time	100μs maximum (full scale change)
Maximum Inaccuracy	±0.1% @ 25°C (77°F) ±0.3% 0–60°C (32–140°F)
Full Scale Calibration Error	±5 counts @ 20mA current output
Output Calibration Error	±3 counts @ 4mA current output

General Module Specifications	
Digital Input and Output Points Required	16 point (X) Inputs 16 point (Y) Outputs
PLC Update Rate	4 input channels per scan maximum (D2-240, D2-250-1, D2-260 and D2-262 CPU) 2 output channels per scan maximum (D2-240, D2-250-1, D2-260 and D2-262 CPU) 1 input and 1 output channels per scan maximum (D2-230 CPU)
Power Budget Requirement	60mA @ 5VDC (supplied by the base)
External Power Supply Requirement	24VDC (±10%), 80mA max. plus 20mA per loop output
Accuracy vs. Temperature	±45 ppm / °C full scale calibration range (including maximum offset change).
Operating Temperature	0–60°C (32–140°F)
Storage Temperature	–20°C to 70°C (–4°F to 158°F)
Relative Humidity	5–95% (non-condensing)
Environmental Air	No corrosive gases permitted
Vibration	MIL STD 810C 514.2
Shock	MIL STD 810C 516.2
Noise Immunity	NEMA ICS3-304

Combination Analog Configuration Requirements

The F2-4AD2DA analog current input/output module requires 16 discrete input points and 16 discrete output points. The module can be installed in any slot of a DL205 system, except when the D2-230 CPU is used. The available power budget may also be a limiting factor. Check the DL205 PLC User Manual for the particular model of CPU and I/O base being used for more information regarding power budget and number of local, local expansion or remote I/O points.

Special Placement Requirements (D2-230 and Remote I/O Bases)

It is important to examine the configuration if a D2-230 CPU is being used with a multiplexing program. As can be seen in the section on Writing the Control Program, V-memory locations are used to manage the analog data. If the module is placed in a slot so that either the input or the output points do not start on a V-memory boundary, the program instructions aren't able to access the data. This also applies when placing this module in a remote base using a D2-RSSS in the CPU slot.

Correct!

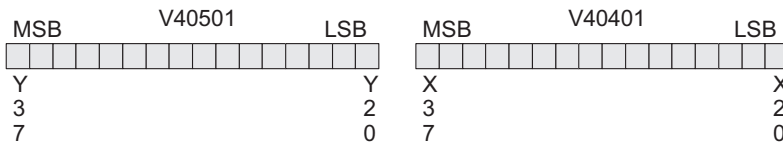
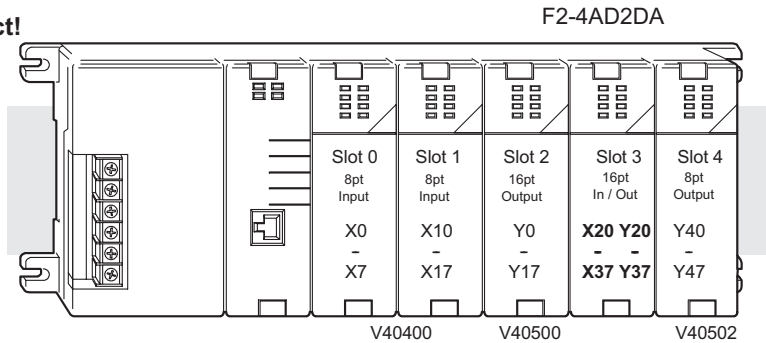

Data can be read and written correctly because the input and output points start on a V-memory boundary address as seen in the table on the following page.

Incorrect

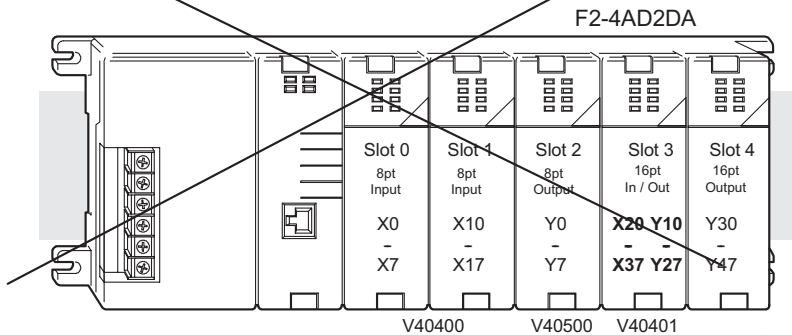

Output data is split over two locations, so instructions cannot write data from a D2-230.

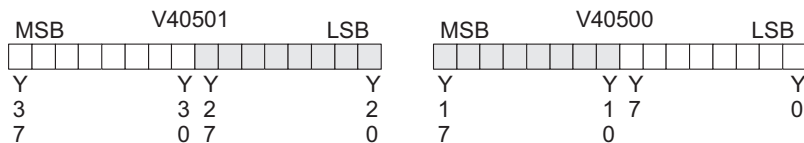

To use the V-memory references required for a D2-230 CPU, the first input and output addresses assigned to the module must be one of the following X and Y locations. The table also shows the V-memory addresses that correspond to these locations.

X	X0	X20	X40	X60	X100	X120	X140	X160
V	V40400	V40401	V40402	V40403	V40404	V40405	V40406	V40407
Y	Y0	Y20	Y40	Y60	Y100	Y120	Y140	Y160
V	V40500	V40501	V40502	V40503	V40504	V40505	V40506	V40507

Connecting the Field Wiring

Wiring Guidelines

Your company may have guidelines for wiring and cable installation. If so, check the guidelines before beginning the installation. Here are some general things to consider:

- Use the shortest wiring route whenever possible.
- Use shielded wiring and ground the shield at the transmitter source. Do not ground the shield at both the module and the source.
- Do not run the signal wiring next to large motors, high current switches, or transformers. This may cause noise problems.
- Route the wiring through an approved cable housing to minimize the risk of accidental damage. Check local and national codes to choose the correct method for your application.

Loop Power Supply Requirements

The F2-4AD2DA module requires at least one field-side power supply. The same or separate power sources can be used for the module supply and the current transmitter supply. The F2-4AD2DA module requires 24VDC (at 80mA) and each current loop requires 20mA (a total of 120mA for six current loops), from the external power supply.

The DL205 AC bases have a built-in 24VDC power supply that provide up to 300mA of current. This can be used instead of a separate supply. Check the power budget to be safe.

It is desirable in some situations to power the transmitters separately in a location remote from the PLC. This will work as long as the transmitter supply meets the current requirements, and the transmitter's minus (-) side and the module supply's minus (-) side are connected together.



WARNING: If the internal 24VDC base power is used, be sure to calculate the power budget. Exceeding the power budget can cause unpredictable system operation that can lead to a risk of personal injury or equipment damage.

The DL205 base has a switching type power supply. As a result of switching noise, ± 3 – 5 counts of instability may be noticed in the analog input data if the base power supply is used. If this is unacceptable, try one of the following:

- Use a separate linear power supply.
- Connect the 24VDC common to the frame ground, which is the screw terminal marked "G" on the base.

When using these methods, the input stability is rated at ± 1 count.

Current Loop Transmitter Impedance

Standard 4–20 mA transmitters and transducers can operate from a wide variety of power supplies. Not all transmitters are alike and the manufacturers often specify a minimum loop or load resistance that must be used with the transmitter.

The F2-4AD2DA provides 250 ohm resistance for each input channel. If the transmitter being used requires a load resistance below 250 ohms, adjustments do not have to be made. However, if the transmitter requires a load resistance higher than 250 ohms, add a resistor in series with the module.

Consider the following example for a transmitter being operated from a 30VDC supply with a recommended load resistance of 750 ohms. Since the module has a 250 ohm resistor, add an additional resistor.

Example:

$$\begin{aligned} R &= Tr - Mr && R - \text{resistor to add} \\ R &= 750 - 250 && Tr - \text{Transmitter total resistance requirement} \\ R &\geq 500 && Mr - \text{Module resistance (internal 250 ohms)} \end{aligned}$$

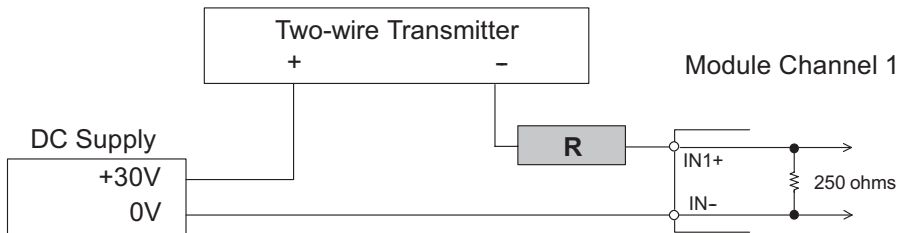

In the example, add a 500 ohm resistor (R) in series with the module.

Wiring Diagram

The F2-4AD2DA module has a removable connector to simplify wiring. Simply squeeze the top and bottom retaining clips and gently pull the connector from the module. Use the following diagram to connect the field wiring. The diagram shows separate module and loop power supplies. If it is desired to use only one external supply, just combine the supply's positive (+) terminals into one node, and remove the loop supply.

NOTE 1: Shields should be connected at their respective signal source.

NOTE 2: Unused channels should remain open (no connections) for minimum power consumption.

NOTE 3: More than one external power supply can be used provided all the power supply commons are connected together.

NOTE 4: A series 217, 0.032 A, fast-acting fuse is recommended for 4–20 mA current input loops.

NOTE 5: If the power supply common of an external power supply is not connected to 0V on the module, then the output of the external transmitter must be isolated. To avoid "ground loop" errors, recommended 4–20 mA transmitter types are:

- For 2 or 3 wire: Isolation between input signal and power supply.
- For 4 wire: Isolation between input signal, power supply, and 4–20 mA output.

NOTE 6: If an analog channel is connected backwards, then incorrect data values will be returned for that channel. Input signals in the ± 4 mA range return a zero value. Signals in the -4 to -40 mA range return a non-zero value.

NOTE 7: To avoid small errors due to terminal block losses, connect 0V, IN- and OUT- on the terminal block as shown. The module's internal connection of these nodes is not sufficient to permit module performance up to the accuracy specifications.

NOTE 8: Choose an output transducer resistance according to the maximum load / power supply listed in the Output Specifications table.

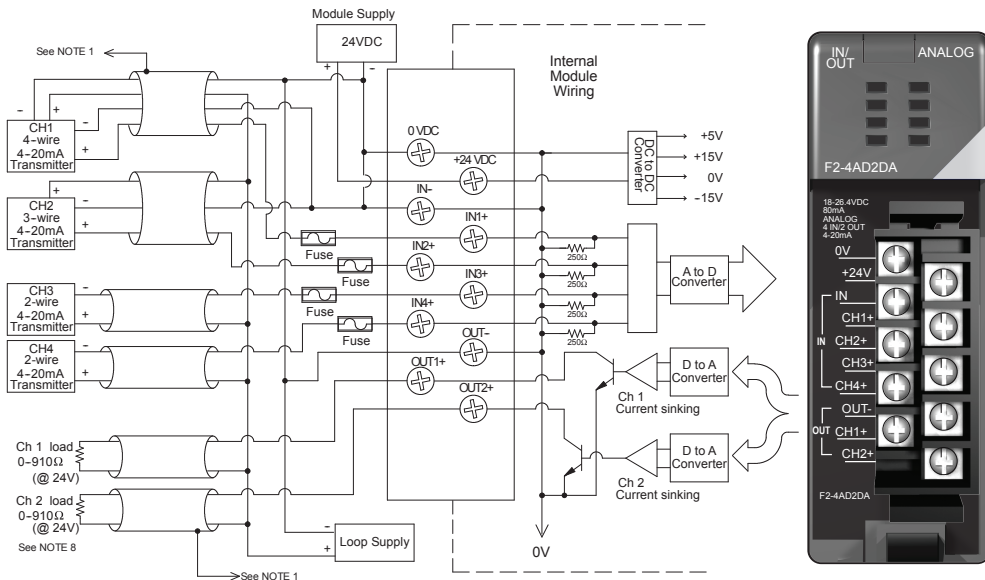

Module Operation

Before beginning to write the control program, it is important to take a few minutes to understand how the module processes the analog signals.

Input Channel Scanning Sequence (Multiplexing) for a D2-230 CPU

The F2-4AD2DA module can supply different amounts of data per scan, depending on the type of CPU being used. The D2-230 can obtain one channel of input data per CPU scan. Since there are four channels, it can take up to four scans to get the data for all channels. Once all channels have been scanned the process starts over with channel 1. Unused channels are not processed, so if only two channels are selected, each channel will be updated every other scan.

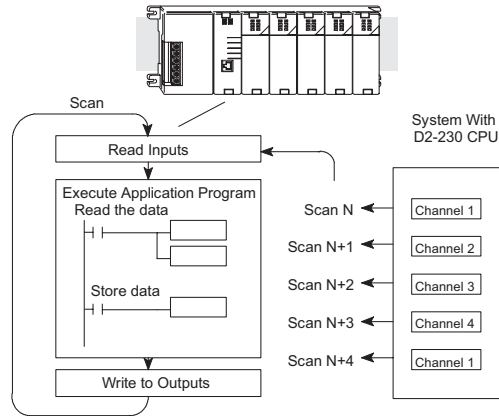

Input Channel Scanning Sequence (Pointer Method) for D2-240, D2-250-1, D2-260 and D2-262 CPUs

If a D2-240, a D2-250-1, a D2-260 or a D2-262 CPU is being used, the input data for all four channels can be obtained in one scan. This is because the D2-240, D2-250-1, D2-260 and D2-262 CPUs supports special V-memory locations that are used to manage the data transfer. This is discussed in more detail in the section on Writing the Control Program later in this chapter.

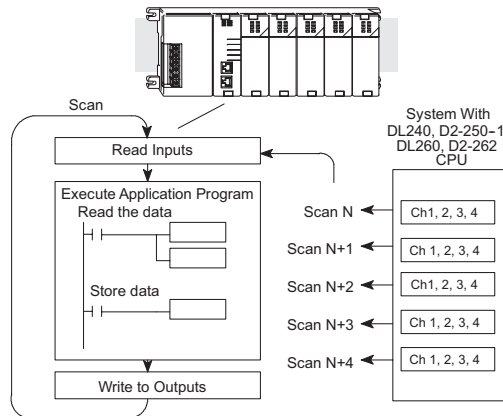

Output Channel Update Sequence (Multiplexing) for a D2-230 CPU

If a D2-230 CPU is used, only one channel of data can be sent to the output module on each scan. Since there are two channels, it can take two scans to update both channels. However, if only one channel is being used, then that channel can be updated on every scan.

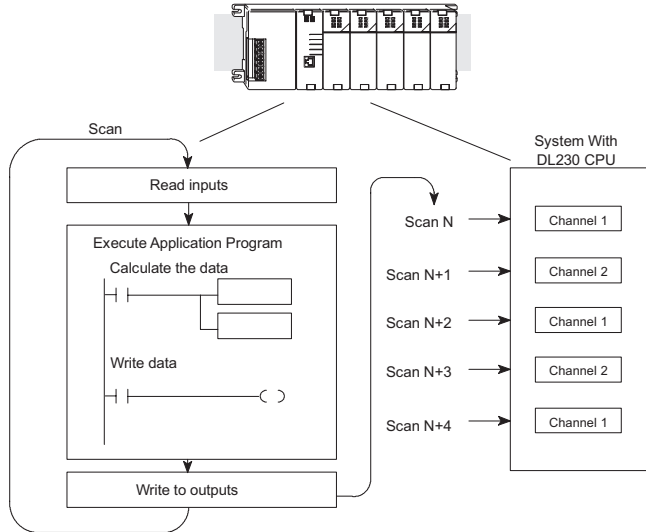

Output Channel Update Sequence (Pointer Method) for D2-240, D2-250-1, D2-260 and D2-262 CPUs

If either a D2-240, D2-250-1, D2-260 or D2-262 CPU is used with the pointer method, both channels can be updated on every scan. This is because these CPUs support special V-memory locations that are used to manage the data transfer. This is discussed in more detail in the section on Writing the Control Program later in this chapter.

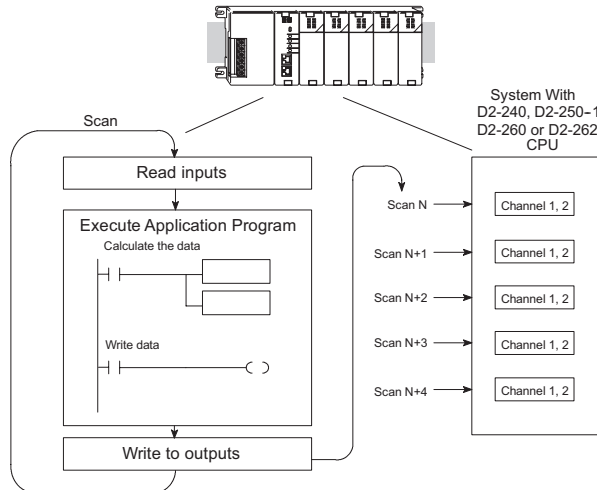

Understanding the I/O Assignments

Remember that the F2-4AD2DA requires 16 discrete input points and 16 discrete output points. These points can be used to obtain:

- An indication of which channel is active,
- The digital representation of the analog signal and,
- Module diagnostic information.

If a D2-240, D2-250-1, D2-260 or D2-262 CPU is being used, these bits may never have to be used, but it may be an aid to help understand the data format.

Since all I/O points are automatically mapped into V-memory, the location of the data words that will be assigned to the module can simply be determined.

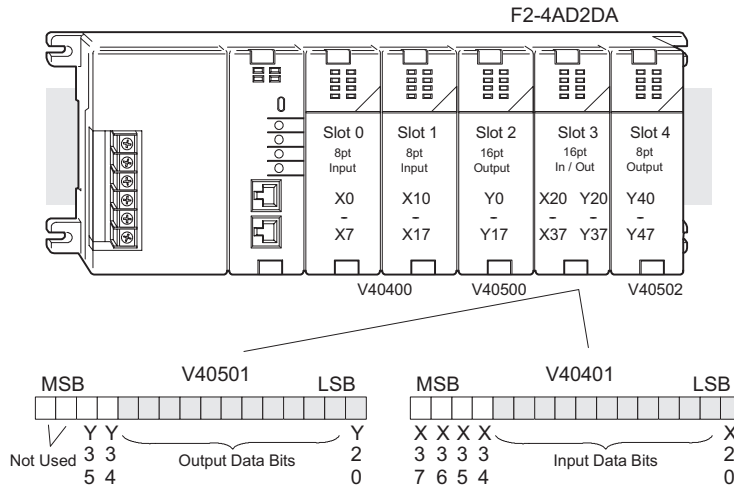

The individual bits in this data word location represent specific information about the analog signal.

Input Data Bits

The first twelve bits of the input word represent the analog data in binary format.

Bit	Value	Bit	Value
0	1	6	64
1	2	7	128
2	4	8	256
3	8	9	512
4	16	10	1024
5	32	11	2048

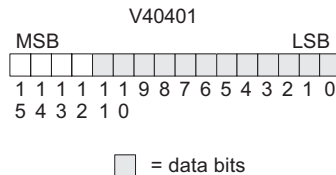

Active Channel Indicator Bits

Two of the inputs are binary encoded to indicate the active input channel. Remember, the V-memory bits are mapped directly to discrete inputs. The module automatically turns these inputs On and Off to indicate the active input channel for each scan.

Scan	X36	X37	Channel
N	Off	Off	1
N+1	Off	On	2
N+2	On	Off	3
N+3	On	On	4
N+4	Off	Off	1

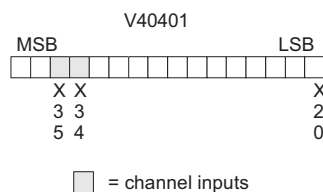

Diagnostic Indicator Inputs

The last two inputs are used for module diagnostics.

Module Busy – The first diagnostic input (X36 in this example) indicates a “busy” condition. This input will always be active on the first PLC scan to tell the CPU the analog data is not valid. After the first scan, the input will normally turn on when environmental (electrical) noise problems are present. The programming examples in the next section will show how this input can be used. The wiring guidelines presented earlier in this chapter provide steps that can help reduce noise problems.

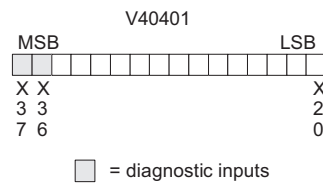

NOTE: When using the pointer method, the value placed into the V-memory location will be 8000 instead of the bit being set.

Module Failure – The last diagnostic input (X37 in this example) indicates that the analog module is not operating. For example, if the 24VDC input power is missing, or if the terminal block is loose, then the module will turn on this input point. The module will also return a data value of zero to further indicate there is a problem. This input point cannot detect which individual channel is at fault. If the cause of the failure goes away, the module turns this bit off.

Output Data Bits

The first twelve bits of the output word represent the analog data in binary format.

Bit	Value	Bit	Value
0	1	6	64
1	2	7	128
2	4	8	256
3	8	9	512
4	16	10	1024
5	32	11	2048

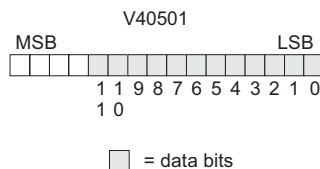

Output Channel Selection Bits

Two of the outputs select the active channel. Remember, the V-memory bits are mapped directly to discrete outputs. Turning a bit Off selects its channel. By controlling these outputs, the channel(s) to be updated can be selected.

Y35	Y34	Channel
On	Off	1
Off	On	2
Off	Off	1 & 2 (same data to both channels)
On	On	None (both channels hold current values)

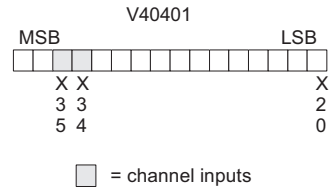

Module Resolution

Since the module has 12-bit resolution, the analog signal is converted into 4096 counts ranging from 0–4095 (212). For example, a 4mA signal would be 0, and a 20mA signal would be 4095. This is equivalent to a binary value of 0000 0000 0000 to 1111 1111 1111, or 000 to FFF hexadecimal. The diagram shows how this relates to the signal range.

Each count can also be expressed in terms of the signal level by using the equation shown.

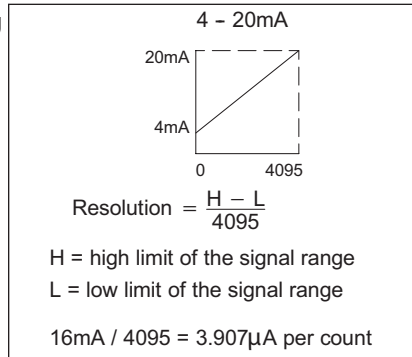

Writing the Control Program

Before starting to write the program, some supplemental examples can be very helpful to the programmer, such as:

- Input power failure detection
- Output data calculation
- Input data scaling

Analog Input Failure Detection

The analog module has a microcontroller that can diagnose analog input circuit problems. Ladder logic can be written to detect these problems. The following rung shows an input point that would be assigned if the module was used as shown in the previous and following examples.

Calculating the Digital Value

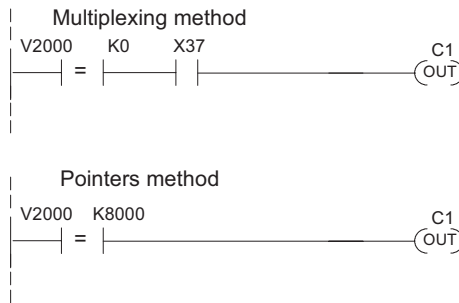

V-memory location V2000 holds channel 1 data. When a data value of zero is returned and input X37 is on, then the analog channel is not operating properly.

V-memory location V2000 holds channel 1 data. When a data value of 8000 is returned, then the analog channel is not operating properly.

The control program must calculate the digital value that is sent to the analog output.

Several methods can be used to do this, but the best method is to convert the values to engineering units. This is accomplished by using the formula shown.

Adjustments may need to be made to the formula depending on the scale of the engineering units.

Consider the following example which controls pressure from 0.0–99.9 PSI. Using the formula will calculate the digital value to be sent to the analog output. The example shows the conversion required to yield 49.4 PSI. The multiplier of 10 is used because the decimal portion of 49.4 cannot be loaded in the program, so it is shifted right one decimal place to make a usable value of 494.

$$A = U \frac{4095}{H-L}$$

A = Analog Value (0–4095)

U = Engineering Units

H = High limit of the engineering unit range

L = Low limit of the engineering unit range

$$A = 10U \frac{4095}{10 (H-L)}$$

$$A = 494 \frac{4095}{(1000-0)}$$

$$A = 2023$$

Chapter 14: F2-4AD2DA, 4-Ch. In / 2-Ch. Out Analog Combination

The example program below shows how to write the program to perform engineering unit conversions. This example will work with all CPUs and assumes that the engineering unit values have been calculated or loaded and stored in V2300 and V2301 for channels 1 and 2 respectively. Also, the final values are moved to V2004 and V2005, which are memory locations that are used in the following examples. Any user V-memory locations can be used, but they must match the locations that are specified as the source for the output data (see the next section for an example).



NOTE: Since the D2-250 can do math operations in BCD format, it is better to perform the math calculations in BCD.

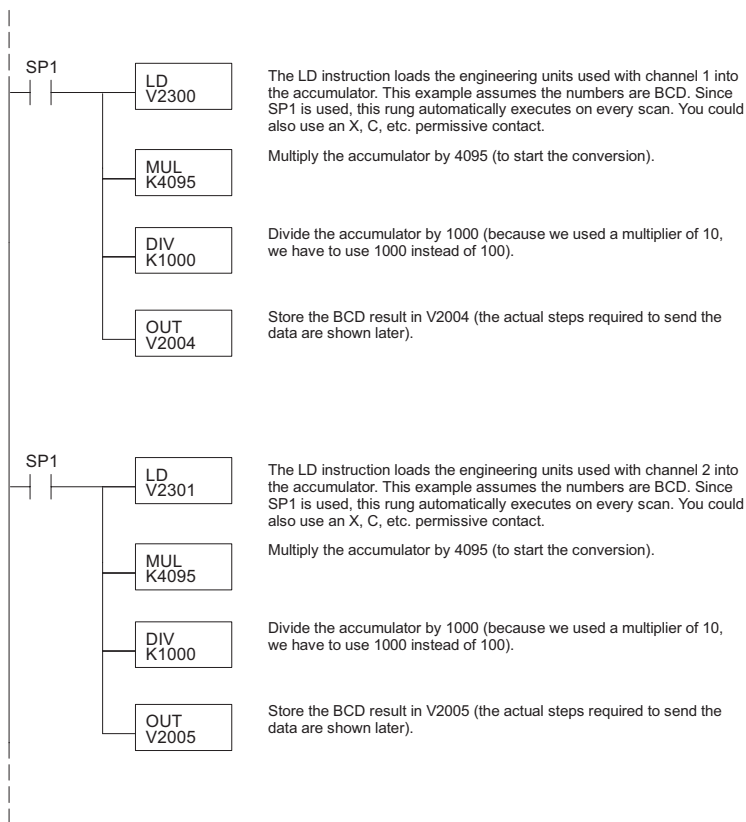

Scaling the Input Data

Most applications usually require measurements in engineering units, which provide more meaningful data. This is accomplished by using the conversion formula shown.

Adjustments to the formula may be needed depending on the scale chosen for the engineering units.

For example, if pressure (PSI) is to be measured with a scale of 0.0–99.9, a multiplication factor of 10 would be needed in order to imply a decimal place when the value is used in the user program.

$$\text{Units} = A \frac{H-L}{4095}$$

U = Engineering Units
 A = Analog Value (0–4095)
 H = High limit of the engineering unit range
 L = Low limit of the engineering unit range

Example without multiplier

$$\text{Units} = A \frac{H-L}{4095}$$

$$\text{Units} = 2024 \frac{100-0}{4095}$$

$$\text{Units} = 49$$

Example with multiplier

$$\text{Units} = 10A \frac{H-L}{4095}$$

$$\text{Units} = 20240 \frac{100-0}{4095}$$

$$\text{Units} = 494$$

Analog Value of 2024, slightly less than half scale, should yield 49.4 PSI.

The following rung of logic is an example showing how the program can be written to perform the engineering unit conversion. This example assumes the data is in BCD format before being loaded into the appropriate V-memory locations using instructions that apply to the CPU module being used.

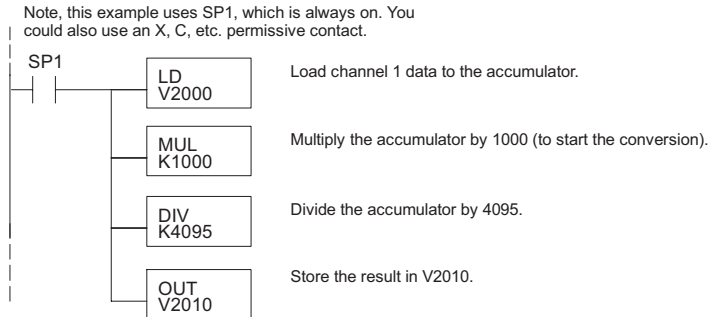

Read / Write Program (Pointer Method) for D2-240, D2-250-1, D2-260 and D2-262 CPUs

The D2-240, D2-250-1, D2-260 and D2-262 CPUs have special V-memory locations assigned to each base slot that simplifies the programming requirements. The V-memory locations:

- Specify the number of input and output channels to scan.
- Specify the storage location for the input data.
- Specify the source location for the output data.



NOTE: In order to use the pointer method, D2-250 CPUs must have firmware revision 1.09 or later, and F2-4AD2DA modules must be revision C1 or later

The following example rung of logic shows how to setup these locations. Place this rung anywhere in the ladder program, or in the initial stage if stage programming instructions are being used.

In this example V2000 and V2004 are used to store the calculated values, but any V-memory location can be used. For this example, the analog module is installed in slot 3. Be sure to use the V-memory locations for which ever slot the module is placed in your system. The pointer method automatically converts values to binary.

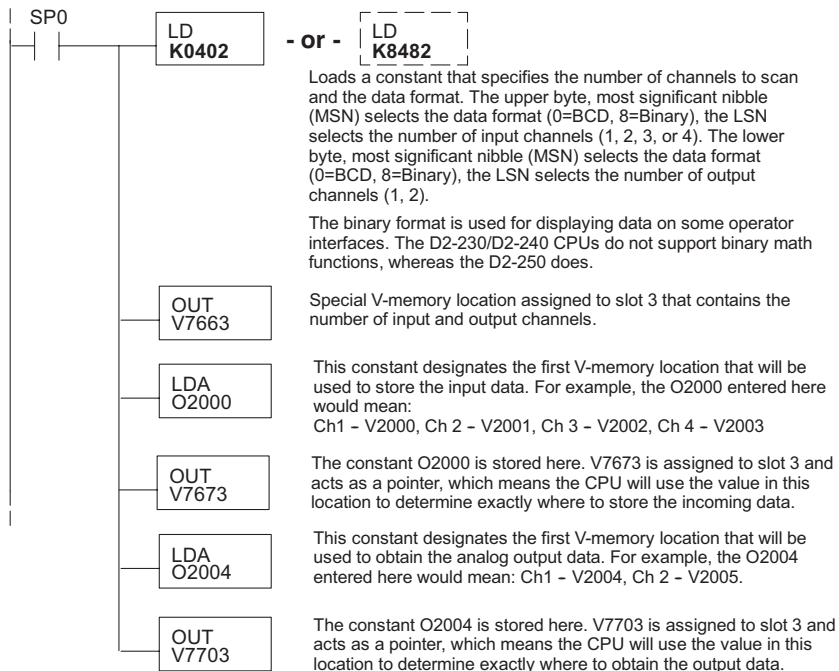

The following tables show the special V-memory locations used by the D2-240, D2-250-1, D2-260 and D2-262 for the CPU base and local expansion base I/O slots. Slot 0 (zero) is the module next to the CPU or D2-CM module. Slot 1 is the module two places from the CPU or D2-CM, and so on. Remember, the CPU only examines the pointer values at these locations after a mode transition. Also, if the D2-230 (multiplexing) method is used, verify that these addresses in the CPU are 0 (zero).

The table below applies to the D2-240, D2-250-1, D2-260 and D2-262 CPU base.

CPU Base: Analog In/Out Module Slot-Dependent V-memory Locations								
Slot	0	1	2	3	4	5	6	7
No. of Channels	V7660	V7661	V7662	V7663	V7664	V7665	V7666	V7667
Input Pointer	V7670	V7671	V7672	V7673	V7674	V7675	V7676	V7677
Output Pointer	V7700	V7701	V7702	V7703	V7704	V7705	V7706	V7707

The table below applies to the D2-250-1, D2-260 or D2-262 CPU base 1.

Expansion Base D2-CM #1: Analog In/Out Module Slot-Dependent V-memory Locations								
Slot.	0	1	2	3	4	5	6	7
No. of Channels	V36000	V36001	V36002	V36003	V36004	V36005	V36006	V36007
Input Pointer	V36010	V36011	V36012	V36013	V36014	V36015	V36016	V36017
Output Pointer	V36020	V36021	V36022	V36023	V36024	V36025	V36026	V36027

The table below applies to the D2-250-1, D2-260 or D2-262 CPU base 2.

Expansion Base D2-CM #2: Analog In/Out Module Slot-Dependent V-memory Locations								
Slot	0	1	2	3	4	5	6	7
No. of Channels	V36100	V36101	V36102	V36103	V36104	V36105	V36106	V36107
Input Pointer	V36110	V36111	V36112	V36113	V36114	V36115	V36116	V36117
Output Pointer	V36120	V36121	V36122	V36123	V36124	V36125	V36126	V36127

The table below applies to the D2-260 and D2-262 CPU base 3.

Expansion Base D2-CM #3: Analog In/Out Module Slot-Dependent V-memory Locations								
Slot	0	1	2	3	4	5	6	7
No. of Channels	V36200	V36201	V36202	V36203	V36204	V36205	V36206	V36207
Input Pointer	V36210	V36211	V36212	V36213	V36214	V36215	V36216	V36217
Output Pointer	V36220	V36221	V36222	V36223	V36224	V36225	V36226	V36227

The table below applies to the D2-260 and D2-262 CPU base 4.

Expansion Base D2-CM #4: Analog In/Out Module Slot-Dependent V-memory Locations								
Slot	0	1	2	3	4	5	6	7
No. of Channels	V36300	V36301	V36302	V36303	V36304	V36305	V36306	V36307
Input Pointer	V36310	V36311	V36312	V36313	V36314	V36315	V36316	V36317
Output Pointer	V36320	V36321	V36322	V36323	V36324	V36325	V36326	V36327

Read Input Values (Multiplexing)

The D2-230 CPU does not use special V-memory locations for transferring data. Since all channels are multiplexed into a single data word, the control program must be setup to determine which channel is being read. Since the module appears as X input points to the CPU, simply use the active channel status bits to determine which channel is being read.

Note, this example is for a module installed in slot 3, as shown in the previous examples. The addresses used would be different if the module was used in a different slot. These rungs can be placed anywhere in the program or if stage programming is being used, place them in a stage that is always active.

The following multiplexing example can be used with all of the DL205 CPUs.

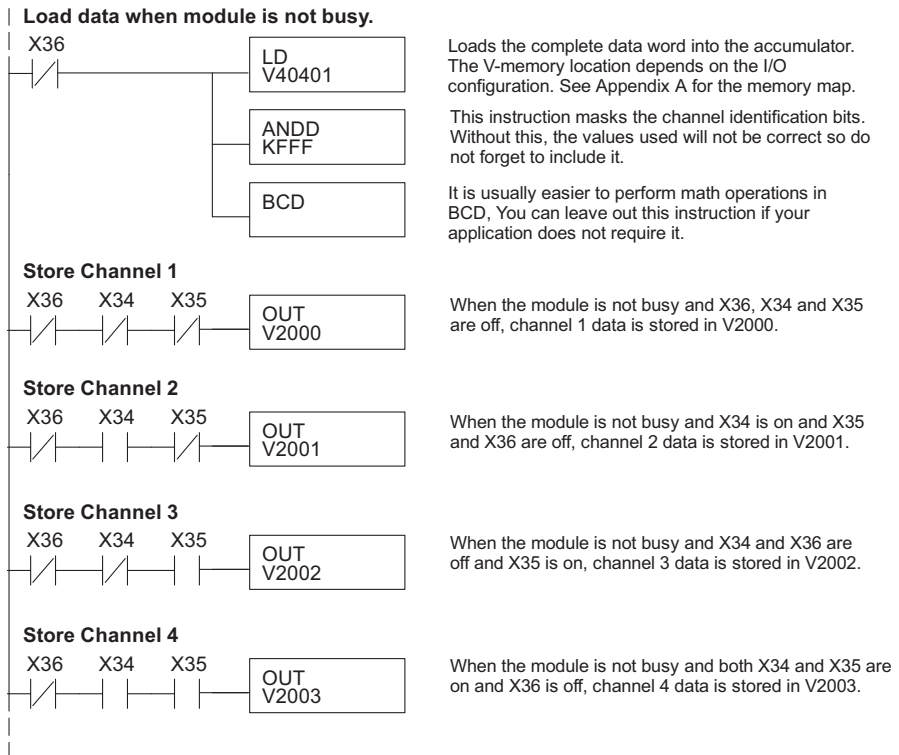

Single Input Channel Selected (Multiplexing)

Since it isn't necessary to determine which channel is selected, the single channel example shown below can be implemented in the user program.

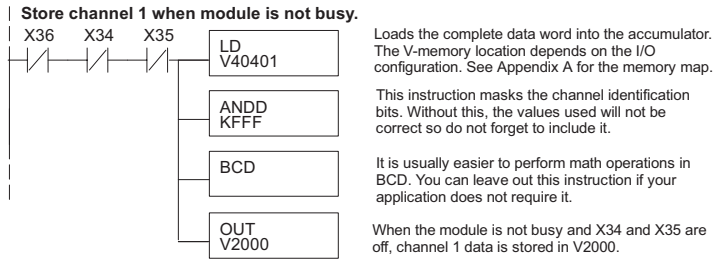

Write Output Values (Multiplexing)

Since all channels are multiplexed into a single data word, the control program can be setup to determine which channel to write the data to. Since the module appears as Y output points to the CPU, it is simple to use the channel selection outputs to determine which channel to update.

Note, this example is for a module installed in slot 3, as shown in the previous examples. The addresses used would be different if the module was used in a different slot. These rungs can be placed anywhere in the program or if stage programming is being used, place them in a stage that is always active.

This example is a two-channel multiplexer that updates each channel on alternate scans. Relay SP7 is a special relay that is On for one scan, then Off for one scan. This multiplexing example can be used with all of the DL205 CPUs.



NOTE: Binary data must be sent to the output module. If the data is already in binary format, do not use the BIN instruction shown in this example.

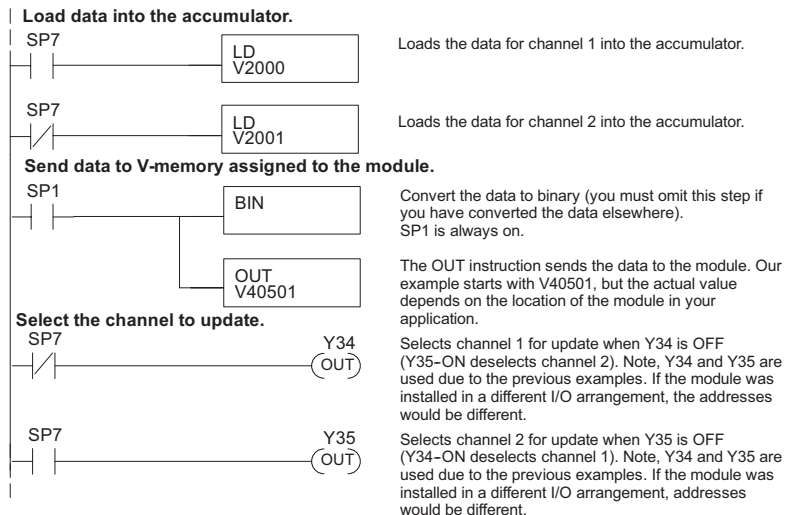

Write Data to One Channel

If only one channel is being used, or if the updates are to be controlled separately, the following logic can be used.

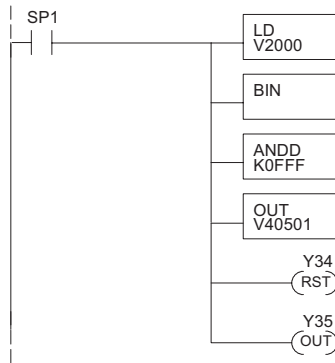

The LD instruction loads the data into the accumulator. Since SP1 is used, this rung automatically executes on every scan. You could also use an X, C, etc. permissive contact.

The BIN instruction converts the accumulator data to binary (you must omit this step if you have already converted the data elsewhere).

The ANDD instruction masks off the channel select bits to prevent an accidental channel selection.

The OUT instruction sends the data to the module. Our example starts with V40501, but the actual value depends on the location of the module in your application.

Y34-OFF selects channel 1 for updating.

Y35-ON deselected channel 2 (do not update).

Write the same Data to Both Channels

If both channel select outputs are Off, then both channels will be updated with the same data.

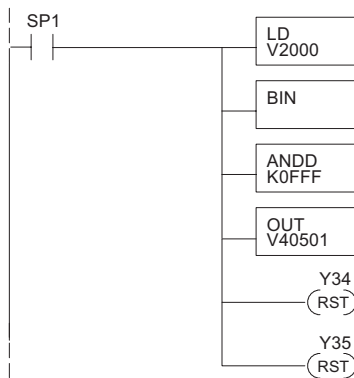

The LD instruction loads the data into the accumulator. Since SP1 is used, this rung automatically executes on every scan. You could also use an X, C, etc. permissive contact.

The BIN instruction converts the accumulator data to binary (you must omit this step if you have already converted the data elsewhere).

The ANDD instruction masks off the channel select bits to prevent an accidental channel selection.

The OUT instruction sends the data to the module. Our example starts with V40501, but the actual value depends on the location of the module in your application.

Y34-OFF selects channel 1 for updating.

Y35-OFF selects channel 2 for updating.

Analog and Digital Value Conversions

It is sometimes useful to do quick conversions between the signal levels and the digital values. This can be helpful during startup and/or troubleshooting. The following table shows some formulas to help with the conversions.

Range	If the digital value is known	If the analog signal level is known.
4-20 mA	$A = \frac{16D}{4095} + 4$	$D = \frac{4095}{16} (A - 4)$

For example, if a 10mA signal level is needed, use the formula to the right to determine the digital value "D" to be stored in the V-memory location which is designated to store the data.

$$D = \frac{4095}{16} (A - 4)$$

$$D = \frac{4095}{16} (10\text{mA} - 4)$$

$$D = (255.93) (6) \quad D = 1536$$

Filtering Input Noise (D2-250-1, D2-260 and D2-262 CPUs Only)

Add the following logic to filter and smooth analog input noise in D2-250-1, D2-260 or D2-262 CPUs. This is especially useful when using PID loops. Noise can be generated by the field device and/or induced by field wiring.

In the following example, the analog value in BCD is first converted to a binary number. Memory location V1400 is the designated workspace in this example. The MULR instruction is the filter factor, which can be from 0.1–0.9. The example uses 0.2. A smaller filter factor increases filtering. A higher precision value can be used, but it is not generally needed. The filtered value is then converted back to binary and then to BCD. The filtered value is stored in location V1402 for use in your application or PID loop.

NOTE: Be careful not to do a multiple number conversion on a value. For example, if the pointer method is used to get the analog value, it is in BCD and must be converted to binary. However, if the conventional method is used to read a value and the first twelve bits are masked, then it is already in binary and no conversion using the BIN instruction is needed.



NOTE: Please review intelligent instructions (IBox) in Chapter 5, which simplify this and other functions. The IBox instructions are supported by the D2-250-1, D2-260 and D2-262.

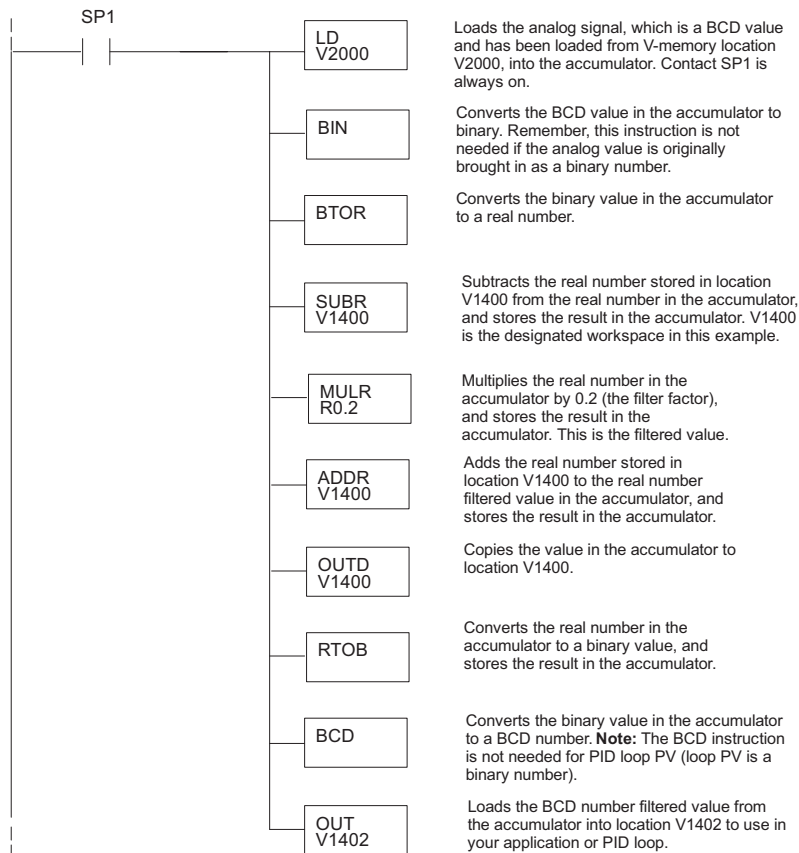

F2-8AD4DA-1 8-CH. IN/4-CH. OUT CURRENT ANALOG COMBINATION



In This Chapter...

Module Specifications	15-2
Connecting the Field Wiring	15-6
Module Operation	15-9
Special V-Memory Locations	15-13
Writing the Control Program	15-16

Module Specifications

The F2-8AD4DA-1 Analog Current Input/Output module provides several hardware features:

- Analog inputs and outputs are optically isolated from the PLC logic.
- The module has a removable terminal block so the module can be easily removed or changed without disconnecting the wiring.
- All input and output channels are updated in one scan.
- On-board active analog filtering, two CISC microcontrollers and CPLD provide digital signal processing to maintain precision analog measurements in noisy environments.
- Low-power CMOS design requires only 100mA from an external 18–26.4 VDC power supply.
- Input resolution is independently adjustable for each channel. Users may select 12-bit, 14-bit or 16-bit.
- Output resolution is 16-bit.
- Broken transmitter detection bit (input <2mA) for use with 4–20 mA input device.
- Each input can be independently configured to return the present value, or to track and hold the maximum or minimum value.
- No jumper settings.

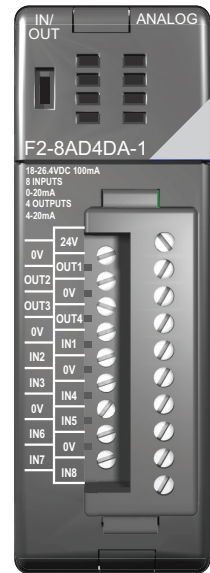

F2-8AD4DA-1

F2-8AD4DA-1 Requirements

The F2-8AD4DA-1 Analog Current Input/Output Module requires one of the following components as a CPU or controller.

Hardware and Firmware Requirements		
Base Type	CPU/Controller	Firmware Version
Local	D2-250-1	4.40 or later
	D2-260	2.20 or later
	D2-262	1.0 TBD
Expansion	D2-CM	1.30 or later
Remote I/O	H2-EBC(-F)	2.1.441 or later
	H2-EBC100	4.0.457 or later

Chapter 15: F2-8AD4DA-1 8-Ch. In / 4-Ch. Out Analog Current Combination

The following tables provide the specifications for the F2-8AD4DA-1 Analog Current Input/Output Module. Review these specifications to be certain that it will meet the requirements of your application.

Input Specifications	
Number of Input Channels	8, single ended (one common)
Input Range	0–20 mA
Input Resolution / Value of LSB	12, 14, or 16-bit; selectable 12-bit, 0–20 mA = 4.88 μ A 14-bit, 0–20 mA = 1.22 μ A 16-bit, 0–20 mA = 0.305 μ A
Input Impedance	100 Ω , \pm 0.1%, 1/4W
Maximum Continuous Overload	\pm 45mA
Loop Supply Voltage Range	18–26.4 VDC
Filter Characteristics	Active low pass; -3 dB @ 80Hz
PLC Input Update Rate	8 channels per scan (max. with pointers; local base)
Sample Duration Time (note)	2ms @ 12-bit; 5.52 ms @ 14-bit; 23ms @ 16-bit
Conversion Time (note)	12-bit = 1.5 ms per channel 14-bit = 6ms per channel 16-bit = 25ms per channel
Conversion Method	Over sampling successive approximation
Accuracy vs. temperature	25ppm / $^{\circ}$ C maximum
Input Stability and Repeatability	\pm 0.025% of range (after 30 minute warm-up)
Input Inaccuracy	0.1% of range maximum
Linearity Error (end to end)	12-bit = \pm 2 counts max. (\pm 0.06% of range) 14-bit = \pm 10 counts max. (\pm 0.06% of range) 16-bit = \pm 40 counts max. (\pm 0.06% of range) Monotonic with no missing codes
Full Scale Calibration Error (not including offset error)	\pm 0.07% of range maximum
Offset Calibration Error	\pm 0.03% of range maximum
Common Mode Rejection	-90dB min. @ DC; -150dB min. @ 50/60Hz
Crosstalk	\pm 0.025% of range max. @ DC, 50/60Hz
Recommended External Fuse	0.032 A, series 217 fast-acting, current inputs



NOTE: The values listed for Sample Duration Time and Conversion Time are for a single channel, and do not include PLC scan times.

Output Specifications	
Number of Output Channels	4
Output Range	4–20 mA
Output Resolution	16-bit; 0.244 μ A / bit
Output Type	Current sourcing at 20mA max.
Output Signal at Power-up & Power-down	≤ 4 mA
External Load Resistance	0–750 Ω
Maximum Inductive Load	1mH
Allowed Load Type	Grounded
Output Voltage Drop	6V max.; 1V min.
Max. Continuous Output Overload	Open circuit protected
Type of Output Protection	Electronically current limited to 20mA or less
PLC Output All Channel Update Time	4ms (local base)
Output Settling Time	0.5 ms max.; 5 μ s min. (full scale change)
Output Ripple	0.005% of full scale
Accuracy vs. Temperature	± 25 ppm/ $^{\circ}$ C max. full scale calibration change ($\pm 0.0025\%$ of range/ $^{\circ}$ C)
Output Stability and Repeatability	± 1 LSB after 10 minute warm-up typical
Output Inaccuracy	0.1% of range maximum
Linearity Error (end to end)	± 33 counts max. ($\pm 0.05\%$ of full scale) Monotonic with no missing codes
Full Scale Calibration Error (not including offset error)	$\pm 0.07\%$ of range maximum
Offset Calibration Error	$\pm 0.03\%$ of range maximum
Crosstalk at DC, 50/60Hz	-70dB or 0.025% of full scale



NOTE: One count in the specifications table is equal to one least significant bit of analog data value (1 in 65536)

General Module Specifications	
Digital Input and Output Points Required	32 point (X) Inputs 32 point (Y) Outputs
Power Budget Requirement	35mA @ 5VDC (supplied by the base)
External Power Supply Requirement	18–26.4 VDC, 100mA maximum plus 20mA per loop output
Field Side to Logic Side Isolation	1800VAC applied for 1 second (100% tested)
Insulation Resistance	>10MΩ @ 500VDC
Operating Temperature	0–60°C (32–140°F); IEC60068-2-14
Storage Temperature	–20°C to 70°C (-4°F to 158°F); IEC60068-2-1, -2-2, -2-14
Relative Humidity	5–95% (non-condensing); IEC60068-2-30
Environmental Air	No corrosive gases permitted; EN61131-2 pollution degree 1
Vibration	MIL STD 810C 514.2; IEC60068-2-6
Shock	MIL STD 810C 516.2; IEC60068-2-27
Noise Immunity	NEMA ICS3-304; IEC61000-4-2, -4-3, -4-4
Emissions	EN61000-6-4 (conducted and radiated RF emissions)
Module Location	Any non-CPU slot in local, expansion, or Ethernet remote base of DL205 system with D2-250-1, D2-260 or D2-262 CPU
Field Wiring	19 point removable terminal block included. Optional remote wiring using ZL-CM20 remote feed-through terminal block module and ZL-2CBL2# cable.
Agency Approvals	UL508; UL6079-15 Zone 2; CE (EN61131-1)

Module Placement and Configuration Requirements

The F2-8AD4DA-1 analog current input/output module requires 32 discrete input and 32 discrete output points.

The module can be installed in any non-CPU slot of D2-250-1, D2-260 or D2-262 local bases, D2-CM expansion bases, H2-EBC(100)(-F) Ethernet remote bases, H2-PBC Profibus slave bases, or H2-WPLCx-xx WinPLC bases.



NOTE: The module is NOT supported by D2-230, D2-240, or D2-250 CPUs. It is also not supported by D2-RMSM and D2-RSSS remote I/O master/slave modules.

The available power budget may also be a limiting factor. Check the user manual for the particular module of CPU and I/O base for more information regarding power budget and number of local, local expansion, or Ethernet remote I/O points.

Connecting the Field Wiring

Wiring Guidelines

Your company may have guidelines for wiring and cable installation. If so, check the guidelines before beginning the installation. Here are some general things to consider:

- Use the shortest wiring route whenever possible.
- Use shielded wiring and ground the shield at the transmitter source. Do not ground the shield at both the module and the load or source.
- Do not run the signal wiring next to large motors, high current switches, or transformers. This may cause noise problems.
- Route the wiring through an approved cable housing to minimize the risk of accidental damage. Check local and national codes to choose the correct method for your application.

User Power Supply Requirements

The F2-8AD4DA-1 module requires at least one field-side power supply. The same or separate power sources can be used for the module supply and the current loop supply. The module requires 18-26.4 VDC (at 100mA) plus 20mA for each current loop (a total of 240mA for twelve current loops), from the external power supply.

The DL205 AC bases have a built-in 24VDC power supply that provide up to 300mA of current. This can be used instead of a separate supply if you are using only one F2-8AD4DA-1 module with less than 10 loops. Check the power budget to be safe.

It is desirable in some situations to power the transmitters separately in a location remote from the PLC. This will work as long as the transmitter supply meets the voltage and current requirements, and that the transmitter and the module power supply negative (-) side are connected together.



WARNING: If the internal 24VDC base power is used, be sure to calculate the power budget. Exceeding the power budget can cause unpredictable system operation that can lead to a risk of personal injury or equipment damage.

The DL205 base has a switching type power supply. As a result of switching noise, ± 3 – 5 counts of instability may be noticed in the analog input data if the base power supply is used. If this is unacceptable, try one of the following:

1. Use a separate linear power supply.
2. Connect the 24VDC common to the frame ground, which is the screw terminal marked "G" on the base.

When using these methods, the input stability is rated at $\pm 0.025\%$ of range.

Current Loop Transmitter Impedance

Standard 0–20 mA and 4–20 mA transmitters and transducers can operate from a wide variety of power supplies. Not all transmitters are alike and the manufacturers often specify a minimum loop or load resistance that must be used with the transmitter.

The F2-8AD4DA-1 provides 100 ohms resistance for each input channel. If the transmitter being used requires a load resistance below 100 ohms, adjustments do not have to be made. However, if the transmitter requires a load resistance higher than 100 ohms, add a resistor in series with the module.

Consider the following example for a transmitter being operated from a 24VDC supply with a recommended load resistance of 750 ohms. Since the module has a 100 ohms resistance, add an additional resistor.

In the example, add a 650 ohm resistor (R) in series with the module.

Example:

$$R = Tr - Mr$$

$$R = 750 - 100$$

$$R \geq 650$$

R - resistor to add
 Tr - Transmitter total resistance requirement
 Mr - Module resistance (internal 100 Ohms)

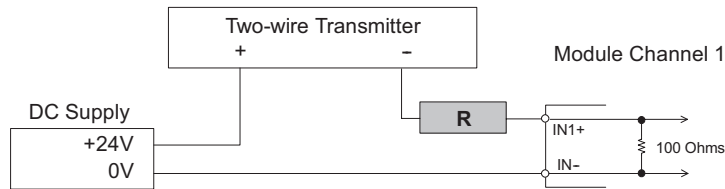

Wiring Diagram

The F2-8AD4DA-1 module has a removable connector to simplify wiring. Simply squeeze the top and bottom retaining clips and gently pull the connector from the module. Use the following diagram to connect the field wiring.

The diagram shows one power supply for both the module and the I/O signal loops. If a separate module and loop supplies are to be used, connect the power supply 0V commons together.

The four wire transmitter connected to input channel 8 is powered by an independent power source. In this case, the transmitter is treated as a 2-wire transmitter.

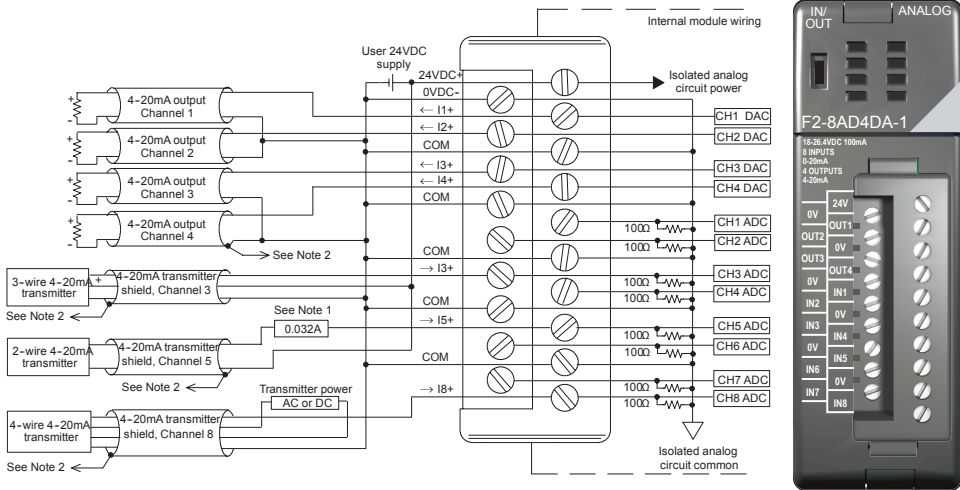

NOTE 1: Shields should be connected at their respective signal source.

NOTE 2: A series 217, 0.032A, fast-acting fuse is recommended for 4-20 mA current input loops.

Module Operation

Input Channel Scanning Sequence (Pointer Method)

If the F2-8AD4DA-1 module is installed in a local (CPU) base, the input data for all eight channels can be obtained in one scan. However, only one channel of input data can be obtained per scan if the module is installed in an expansion, remote I/O, or Profibus slave base.

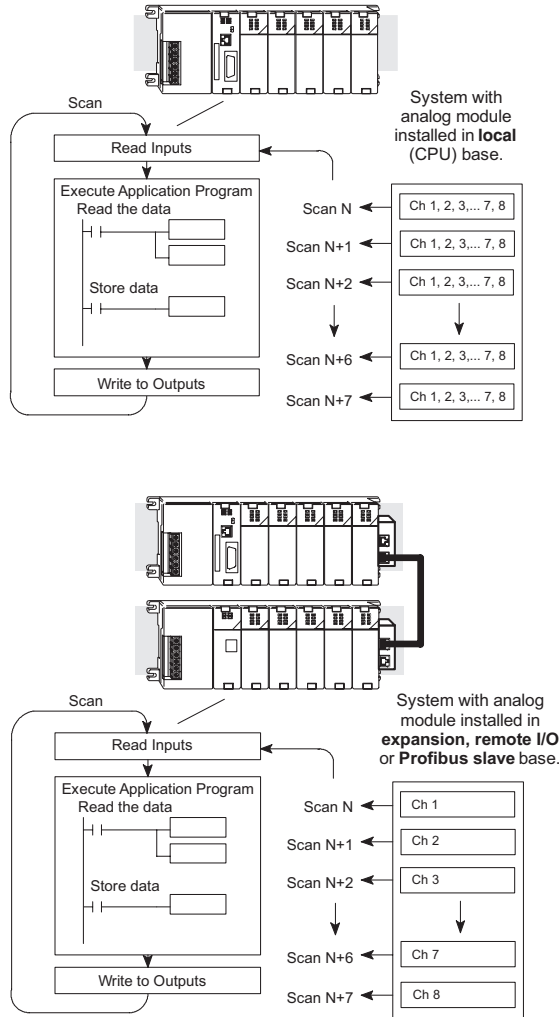

Output Channel Update Sequence (Pointer Method)

If the F2-8AD4DA-1 is installed in a local (CPU) base, all four output channels can be updated on every scan. However, only one channel can be updated per scan if the module is installed in an expansion, remote I/O, or Profibus slave base. The timing is synchronized with the timing of reading the input channels, so each output channel can be updated every eight scans.

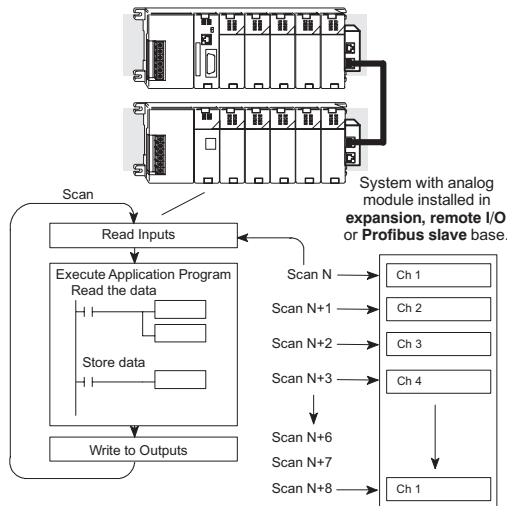
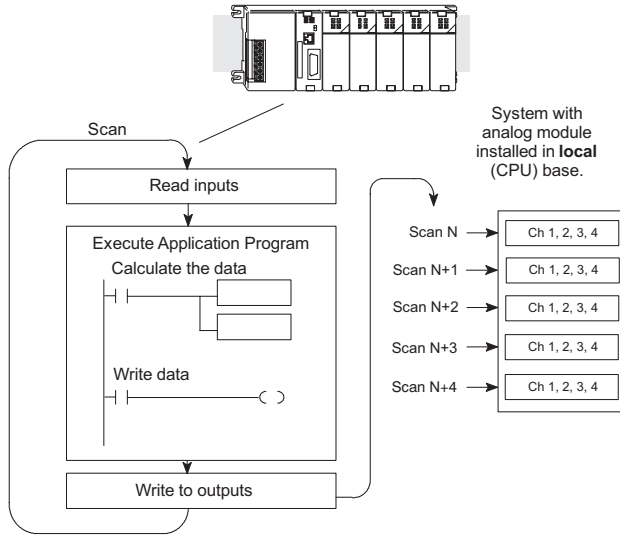

Understanding the I/O Assignments

Remember that the F2-8AD4DA-1 module appears to the CPU as a 32-point discrete input module and a 32-point discrete output module. These points can be used to obtain:

- An indication of which channel is active
- The digital representation of the analog signal
- Module diagnostic information
- Settings for resolution, range, and track and hold

These bits may never have to be used, but it may be an aid to help understand the data format. Since all I/O points are automatically mapped into V-memory, the location of the datawords that will be assigned to the module can simply be determined.

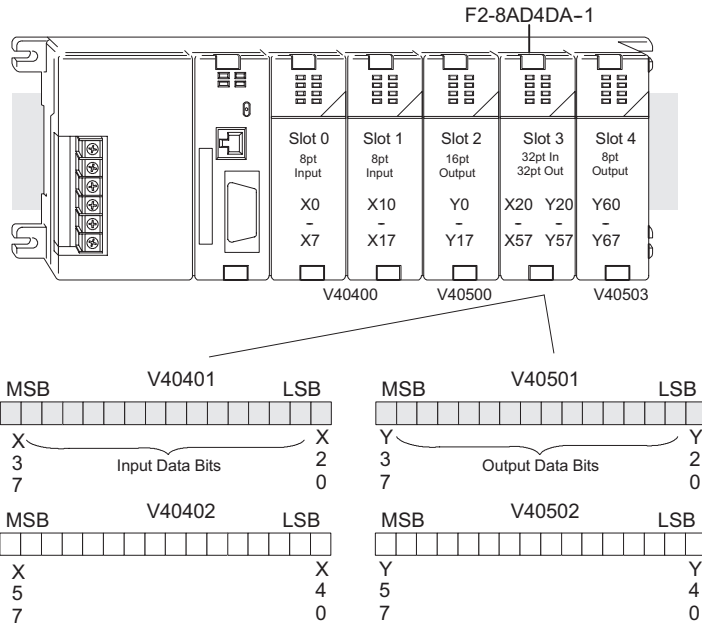

The individual bits in these data word locations represent specific information about the analog signal. (The specific memory locations may vary, depending upon the slot where the F2-8AD4DA-1 module is located.)

Input Data Bits

Depending upon the resolution selected, up to 16-bits of the input word represent the analog data in binary format.

Bit	Value	Bit	Value
0	1	8	256
1	2	9	512
2	4	10	1024
3	8	11	2048
4	16	12	4096
5	32	13	8192
6	64	14	16384
7	128	15	32768

The upper byte of the second input word represents the broken transmitter detection bits for use only with 4–20 mA input devices. The lower byte is not usable by the programmer.

Broken Transmitter Detection Bits (second input word)											
V40402	X	X	X	X	X	X	X	X	X	X	X
Input Address #	57	56	55	54	53	52	51	50	47	40
Input Bit #	15	14	13	12	11	10	9	8	7	0
BT for Channel #	8	7	6	5	4	3	2	1	n/a	n/a

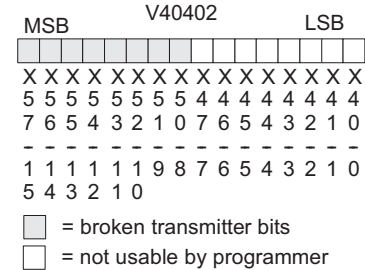
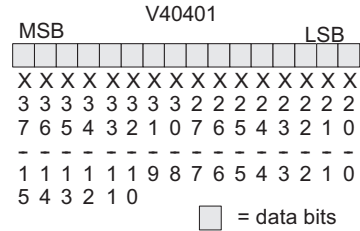

Output Data Bits

All 16-bits of the first output word represent the analog data in binary format.

Bit	Value	Bit	Value
0	1	8	256
1	2	9	512
2	4	10	1024
3	8	11	2048
4	16	12	4096
5	32	13	8192
6	64	14	16384
7	128	15	32768

The second output word is not usable by the programmer.

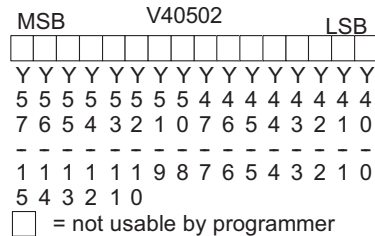
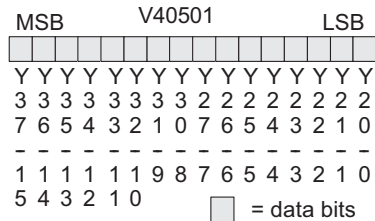

Special V-Memory Locations

The D2-250-1, D2-260 and D2-262 CPUs have special V-memory locations assigned to each base slot that greatly simplifies the programming requirements. These V-memory locations specify:

- The number of input and output channels to scan
- The storage locations for the input and output data
- The resolution for the inputs
- The range selections for the inputs and outputs
- The track and hold selections for the inputs

Module Configuration Registers

The following tables show the special V-memory used by the CPUs for the CPU base and local expansion base I/O slots. Slot 0 is the module slot next to the CPU or D2-CM module. Slot 1 is the module slot two places from the CPU or D2-CM, and so on. The CPU needs to examine the pointer values at these locations only after a mode transition.

CPU Base: Analog In/Out Module Slot-Dependent V-memory Locations								
Slot	0	1	2	3	4	5	6	7
No. of I/O Channels Enabled & Format	V7660	V7661	V7662	V7663	V7664	V7665	V7666	V7667
Input Pointer	V7670	V7671	V7672	V7673	V7674	V7675	V7676	V7677
Output Pointer	V7700	V7701	V7702	V7703	V7704	V7705	V7706	V7707
Input Resolutions	V36400	V36401	V36402	V36403	V36404	V36405	V36406	V36407
(Reserved)	V36410	V36411	V36412	V36413	V36414	V36415	V36416	V36417
Input Track & Hold	V36420	V36421	V36422	V36423	V36424	V36425	V36426	V36427

Expansion Base D2-CM #1: Analog In/Out Module Slot-Dependent V-memory Locations								
Slot	0	1	2	3	4	5	6	7
No. of I/O Channels Enabled & Format	V36000	V36001	V36002	V36003	V36004	V36005	V36006	V36007
Input Pointer	V36010	V36011	V36012	V36013	V36014	V36015	V36016	V36017
Output Pointer	V36020	V36021	V36022	V36023	V36024	V36025	V36026	V36027
Input Resolutions	V36030	V36031	V36032	V36033	V36034	V36035	V36036	V36037
(Reserved)	V36040	V36041	V36042	V36043	V36044	V36045	V36046	V36047
Input Track & Hold	V36050	V36051	V36052	V36053	V36054	V36055	V36056	V36057

Expansion Base D2-CM #2: Analog In/Out Module Slot-Dependent V-memory Locations								
Slot	0	1	2	3	4	5	6	7
No. of I/O Channels Enabled & Format	V36100	V36101	V36102	V36103	V36104	V36105	V36106	V36107
Input Pointer	V36110	V36111	V36112	V36113	V36114	V36115	V36116	V36117
Output Pointer	V36120	V36121	V36122	V36123	V36124	V36125	V36126	V36127
Input Resolutions	V36130	V36131	V36132	V36133	V36134	V36135	V36136	V36137
(Reserved)	V36140	V36141	V36142	V36143	V36144	V36145	V36146	V36147
Input Track & Hold	V36150	V36151	V36152	V36153	V36154	V36155	V36156	V36157

Expansion Base D2-CM #3: Analog In/Out Module Slot-Dependent V-memory Locations								
Slot	0	1	2	3	4	5	6	7
No. of I/O Channels Enabled & Format	V36200	V36201	V36202	V36203	V36204	V36205	V36206	V36207
Input Pointer	V36210	V36211	V36212	V36213	V36214	V36215	V36216	V36217
Output Pointer	V36220	V36221	V36222	V36223	V36224	V36225	V36226	V36227
Input Resolutions	V36230	V36231	V36232	V36233	V36234	V36235	V36236	V36237
(Reserved)	V36240	V36241	V36242	V36243	V36244	V36245	V36246	V36247
Input Track & Hold	V36250	V36251	V36252	V36253	V36254	V36255	V36256	V36257

Expansion Base D2-CM #4: Analog In/Out Module Slot-Dependent V-memory Locations								
Slot	0	1	2	3	4	5	6	7
No. of I/O Channels Enabled & Format	V36300	V36301	V36302	V36303	V36304	V36305	V36306	V36307
Input Pointer	V36310	V36311	V36312	V36313	V36314	V36315	V36316	V36317
Output Pointer	V36320	V36321	V36322	V36323	V36324	V36325	V36326	V36327
Input Resolutions	V36330	V36331	V36332	V36333	V36334	V36335	V36336	V36337
(Reserved)	V36340	V36341	V36342	V36343	V36344	V36345	V36346	V36347
Input Track & Hold	V36350	V36351	V36352	V36353	V36354	V36355	V36356	V36357

Number of I/O Channels Enabled & Data Format

Load this V-memory location with a constant that specifies the number of enabled I/O channels and their data formats. The upper byte applies to the inputs, and the lower byte applies to the outputs. The most significant nibbles specify the data formats, and the least significant nibbles specify the number of channels enabled.

V-memory Locations for No. of I/O Channels Enabled & Format								
No. of Channels Enabled	1	2	3	4	5	6	7	8
BCD Input	K01xx	K02xx	K03xx	K04xx	K05xx	K06xx	K07xx	K08xx
Binary Input	K81xx	K82xx	K83xx	K84xx	K85xx	K86xx	K87xx	K88xx
BCD Output	Kxx01	Kxx02	Kxx03	Kxx04	n/a	n/a	n/a	n/a
Binary Output	Kxx81	Kxx82	Kxx83	Kxx84	n/a	n/a	n/a	n/a

Input Selection Resolution Bits

Each of the eight input channels can be individually disabled or configured for 12, 14, or 16-bit resolution.

V36403: (specific memory location will vary depending upon the base and slot location).

15	14	13	12	11	10	9	8	7	6	5	4	3	2	1	0
R-8H	R-8L	R-7H	R-7L	R-6H	R-6L	R-5H	R-5L	R-4H	R-4L	R-3H	R-3L	R-2H	R-2L	R-1H	R-1L

RnH = Resolution channel n High bit

RnL = Resolution channel n Low bit

Input Resolution Select	RnH	RnL
12-bit	0	0
14-bit	0	1
16-bit	1	0
Disabled	1	1

Example: Input channels 1–4 are 12-bit, channel 5 is 14-bit, and channel 6 is 16-bit, and channels 7 and 8 are disabled; V36403 - F900(hex).

15	14	13	12	11	10	9	8	7	6	5	4	3	2	1	0
R-8H	R-8L	R-7H	R-7L	R-6H	R-6L	R-5H	R-5L	R-4H	R-4L	R-3H	R-3L	R-2H	R-2L	R-1H	R-1L
1	1	1	1	1	0	0	1	0	0	0	0	0	0	0	0
F				9				0				0			

Input Track and Hold Selection Bits

The track and hold feature for each of the eight inputs can be individually configured for minimum, maximum, no hold, or reset held value. This configuration can be changed “on the fly” while the program is running.

V36423: (specific memory location will vary depending upon the base and slot location).

15	14	13	12	11	10	9	8	7	6	5	4	3	2	1	0
T-8H	T-8L	T-7H	T-7L	T-6H	T-6L	T-5H	T-5L	T-4H	T-4L	T-3H	T-3L	T-2H	T-2L	T-1H	T-1L

TnH = Track and hold channel n High bit

TnL = Track and hold channel n Low bit

Track and Hold Select	TnH	TnL	Result
No Track and Hold	0	0	Returns real time input value
Track and Hold Minimum Value	0	1	Maintains lowest measured value
Track and Hold Maximum Value	1	0	Maintains highest measured value
Reset Track and Hold Value	1	1	Resets previously held input value

Example: Input channel track and hold settings:

1-3 = none, ch 4-5 = minimum, ch 6-7 = maximum, ch 8 = reset; V36423=E940(hex).

15	14	13	12	11	10	9	8	7	6	5	4	3	2	1	0
T-8H	T-8L	T-7H	T-7L	T-6H	T-6L	T-5H	T-5L	T-4H	T-4L	T-3H	T-3L	T-2H	T-2L	T-1H	T-1L
1	1	1	0	1	0	0	1	0	1	0	0	0	0	0	0
E				9				4				0			

Writing the Control Program

Configuring the Module to Read/Write I/O (Pointer Method) for D2-250-1, D2-260 and D2-262

The example programs that follow show how to configure the special V-memory locations to read/write data from/to the I/O module. The module configuration rung needs to be read by the CPU only after a mode transition, and does not need to be read every scan. Place the configuration rung anywhere in the ladder program, or in the initial stage if stage programming instructions is being used. This is all that is required to read the input data and write the output data to/from the V-memory locations. Once the input data is in V-memory, math can be used for data calculations, compare the data against preset values, and so forth.

V2000 and V2020 are used as the beginning of the data areas in the example, but any user V-memory locations can be used. Also, these examples assume that the module is installed in slot 3 of the CPU base. The pointer V-memory locations determined by the layout of the application should be used.

Module Configuration Example 1:

Number of Channels = 8 in, 4 out,
 Data Format = binary in, BCD out,
 Input Resolution = 16-bit,
 Input Track and Hold = none, real time value.

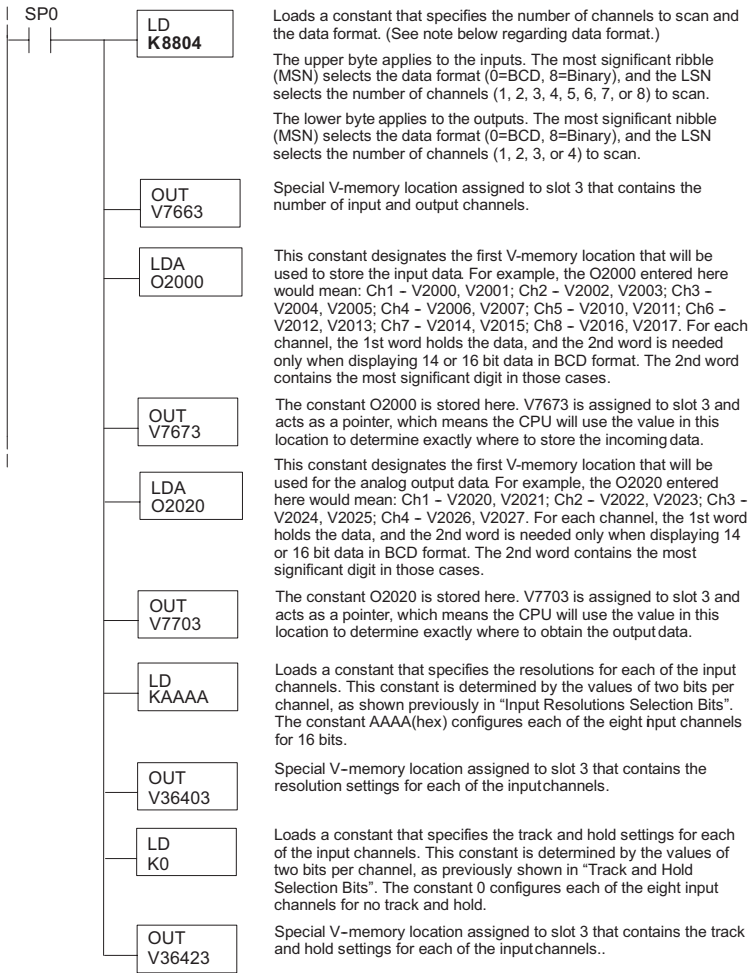

NOTE: Binary data format is recommended for 14 or 16-bit resolution input data, especially if the input data is to be used in any math instructions (DL205 User Manual, ch.5). There is only one V-memory word (16-bits) available for the actual data. Although the 12-bit resolution maximum value of 4095 can be stored in one word using either binary or BCD formats, the 14 and 16-bit resolution maximum values of 16383 and 65535 both exceed the BCD format's maximum single word capacity of 9999. Double word math would be required for 14 or 16-bit data in BCD format. **Binary data format is also useful for displaying data on some operator interfaces.**



Module Configuration Example 2:

Number of Channels = 4 in, 4 out,
 Data Format = binary in, BCD out,
 Input Resolution = 14-bit,
 Input Track and Hold = all inputs maximum value.

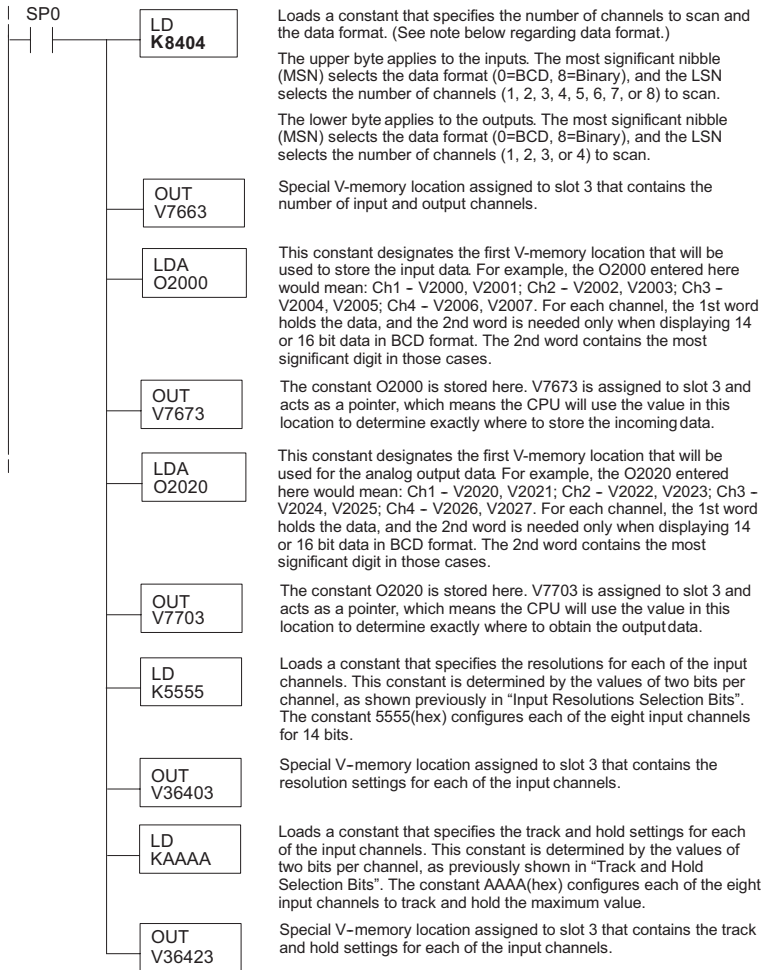

NOTE: Binary data format is recommended for 14 or 16-bit resolution input data, especially if the input data is to be used in any math instructions (DL205 User Manual, ch.5). There is only one V-memory word (16-bits) available for the actual data. Although the 12-bit resolution maximum value of 4095 can be stored in one word using either binary or BCD formats, the 14 and 16-bit resolution maximum values of 16383 and 65535 both exceed the BCD format's maximum single word capacity of 9999. Double word math would be required for 14 or 16-bit data in BCD format. Binary data format is also useful for displaying data on some operator interfaces.



Module Configuration Example 3:

Number of Channels = 4 in, 2 out,
 Data Format = BCD in, BCD out,
 Input Resolution = 12-bit,
 Input Track and Hold = all inputs minimum value.

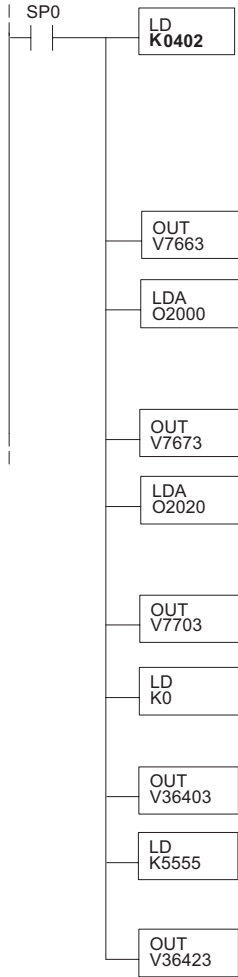

Loads a constant that specifies the number of channels to scan and the data format. (See note below regarding data format.) (The leading zero in this LD instruction is shown for clarity. It can be entered by the programmer, but it will be dropped by the programming software.)

The upper byte applies to the inputs. The most significant nibble (MSN) selects the data format (0=BCD, 8=Binary), and the LSN selects the number of channels (1, 2, 3, 4, 5, 6, 7, or 8) to scan.

The lower byte applies to the outputs. The most significant nibble (MSN) selects the data format (0=BCD, 8=Binary), and the LSN selects the number of channels (1, 2, 3, or 4) to scan.

Special V-memory location assigned to slot 3 that contains the number of input and output channels.

This constant designates the first V-memory location that will be used to store the input data. For example, the O2000 entered here would mean: Ch1 - V2000, V2001; Ch2 - V2002, V2003; Ch3 - V2004, V2005; Ch4 - V2006, V2007. For each channel, the 1st word holds the data, and the 2nd word is needed only when displaying 14 or 16 bit data in BCD format. The 2nd word contains the most significant digit in those cases.

The constant O2000 is stored here. V7673 is assigned to slot 3 and acts as a pointer, which means the CPU will use the value in this location to determine exactly where to store the incoming data.

This constant designates the first V-memory location that will be used for the analog output data. For example, the O2020 entered here would mean: Ch1 - V2020, V2021; Ch2 - V2022, V2023. For each channel, the 1st word holds the data, and the 2nd word is needed only when displaying 14 or 16 bit data in BCD format. The 2nd word contains the most significant digit in those cases.

The constant O2020 is stored here. V7703 is assigned to slot 3 and acts as a pointer, which means the CPU will use the value in this location to determine exactly where to obtain the output data.

Loads a constant that specifies the resolutions for each of the input channels. This constant is determined by the values of two bits per channel, as shown previously in "Input Resolutions Selection Bits". The constant 0 configures each of the eight input channels for 12 bits.

Special V-memory location assigned to slot 3 that contains the resolution settings for each of the input channels.

Loads a constant that specifies the track and hold settings for each of the input channels. This constant is determined by the values of two bits per channel, as previously shown in "Track and Hold Selection Bits". The constant 5555(hex) configures each of the eight input channels to track and hold the minimum value.

Special V-memory location assigned to slot 3 that contains the track and hold settings for each of the input channels..

NOTE: Binary data format is recommended for 14 or 16-bit resolution input data, especially if the input data is to be used in any math instructions (DL205 User Manual, ch.5). There is only one V-memory word (16-bits) available for the actual data. Although the 12-bit resolution maximum value of 4095 can be stored in one word using either binary or BCD formats, the 14 and 16-bit resolution maximum values of 16383 and 65535 both exceed the BCD format's maximum single word capacity of 9999. Double word math would be required for 14 or 16-bit data in BCD format.

Binary data format is also useful for displaying data on some operator interfaces.



Module 12-bit Input Resolution

When the 0–20 mA module inputs are configured for 12-bit resolution, the analog signal is converted into 4096 (2¹²) counts ranging from 0–4095. For example, a 0mA signal would be 0, and a 20mA signal would be 4095. This is equivalent to a binary value of 0000 0000 0000 to 1111 1111 1111, or 000 to FFF hexadecimal. The diagram shows how this relates to the signal range.

Each count can also be expressed in terms of the signal level by using the equation shown.

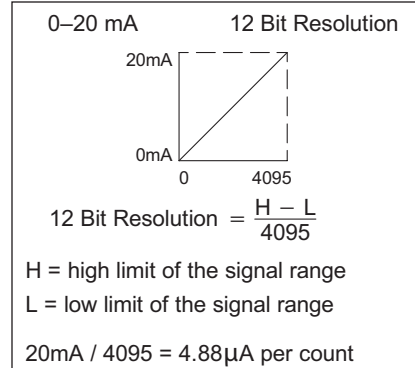

Module 14-bit Input Resolution

When the 0–20 mA module inputs are configured for 14-bit resolution, the analog signal is converted into 16384 (2¹⁴) counts ranging from 0–16383. For example, a 0mA signal would be 0, and a 20mA signal would be 16383. This is equivalent to a binary value of 00 0000 0000 0000 to 11 1111 1111 1111, or 0000 to 3FFF hexadecimal. The diagram shows how this relates to the signal range.

Each count can also be expressed in terms of the signal level by using the equation shown.

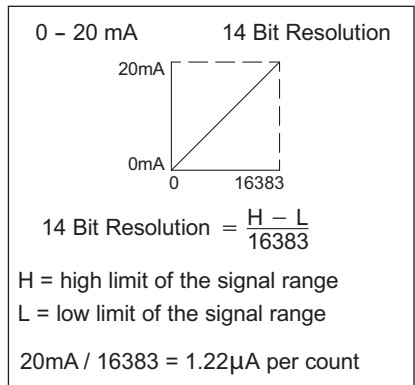

Module 16-bit Input Resolution

When the 0–20 mA module inputs are configured for 16-bit resolution, the analog signal is converted into 65536 (2¹⁶) counts ranging from 0–65535. For example, a 0mA signal would be 0, and a 20mA signal would be 65535. This is equivalent to a binary value of 0000 0000 0000 0000 to 1111 1111 1111 1111, or 0000 to FFFF hexadecimal. The diagram shows how this relates to the signal range.

Each count can also be expressed in terms of the signal level by using the equation shown.

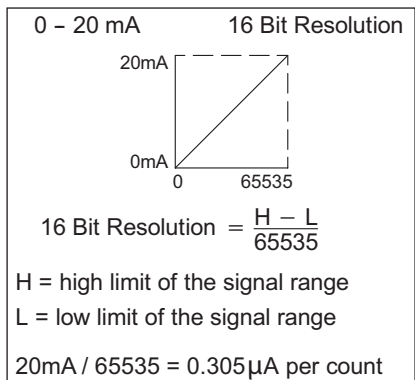

Analog and Digital Input Data Value Conversion

Sometimes it is useful to be able to quickly convert between the signal levels and the digital values. This is especially helpful during machine startup or troubleshooting. The table below provides formulas to simplify the conversion.

$$A = (D)(A_{\max}) / (D_{\max})$$

$$D = (A)(D_{\max}) / (A_{\max})$$

A = Analog value from current transmitter

A_{max} = Maximum analog value

D = Digital value of input provided to PLC CPU

D_{max} = Maximum digital value

Analog and Digital Input Data Conversion			
Resolution	X-mitter Range	If the digital value is known	If the analog signal is known
12-bit 0-4095	0-20 mA 4-20 mA	$A = (D)(20) / 4095$	$D = (A)(4095) / 20$
14-bit 0-16383	0-20 mA 4-20 mA	$A = (D)(20) / 16383$	$D = (A)(16383) / 20$
16-bit 0-65535	0-20 mA 4-20 mA	$A = (D)(20) / 65535$	$D = (A)(65535) / 20$

For example, if 16-bit resolution is being used, and the signal measured is 12mA, the formula can be easily used to determine the digital value (D) that should be stored in the V-memory location that contains the data.

$$D = (A) \frac{65535}{20}$$

$$D = (12)(3276.75)$$

$$D = 39321$$

Notice that the mathematical relationship between the analog and digital values remains the same regardless of whether 4-20 mA or 0-20 mA transmitters are used. Only the engineering unit input scaling will vary, as will be shown later.

Input Value Comparisons: Analog, Digital, Engineering Units

The following table shows how the input analog, digital, and engineering unit values are related to each other. The above example is a measurement of pressure from 0.0-140.0 PSI, using a multiplier of 10 for one implied decimal place.

Analog, Digital, and Engineering Units Input Comparisons					
Analog (mA)	Digital 12-bit	Digital 14-bit	Digital 16-bit	E.U. 0-20 mA Transmitter	E.U. 4-20 mA Transmitter
20	4095	16383	65535	1400	1400
12	2457	9830	39321	840	700
10	2048	8192	32768	700	525
4	819	3277	13107	280	0
0	0	0	0	0	N/A

Scaling the Input Data

Most applications require measurements in engineering units, which provide more meaningful data. This can be accomplished by using the conversion formulas shown below.

$$EU = (A - A_{\text{offset}})(EU_H - EU_L) / (A_{\text{max}} - A_{\text{offset}})$$

$$EU = (D - D_{\text{offset}})(EU_H - EU_L) / (D_{\text{max}} - D_{\text{offset}})$$

- A = analog value from current transmitter
- A_{offset} = 4mA offset when using 4-20 mA current transmitter
- D = digital value of input provided to PLC CPU
- D_{offset} = digital value of 4mA offset with 4-20 mA current transmitter
- EU = engineering units
- EU_H = engineering units high value
- EU_L = engineering units low value

The following examples show a 16-bit measurement of pressure (PSI) from 0.0–140.0. The analog value needs to be multiplied by 10 in order to imply a decimal place when the value is viewed with the programming software. Notice how the calculations differ when the multiplier is used.

Scaling Example

Analog Value = 12.6 mA; Transmitter = 4–20 mA; Resolution = 16-bit
Result should yield 75.2 PSI

Example without multiplier

$$EU = (D - D_{\text{offset}}) \frac{EU_H - EU_L}{D_{\text{max}} - D_{\text{offset}}}$$

$$EU = (41287 - 13107) \frac{140 - 0}{65535 - 13107}$$

$$EU = 75$$

Example with multiplier

$$EU = (10)(D - D_{\text{offset}}) \frac{EU_H - EU_L}{D_{\text{max}} - D_{\text{offset}}}$$

$$EU = (10)(41287 - 13107) \frac{140 - 0}{65535 - 13107}$$

$$EU = 752$$



NOTE: *Binary data format is recommended for 14 or 16-bit resolution input data, especially if the input data is to be used in any math instructions (DL205 User Manual, ch.5). There is only one V-memory word (16-bits) available for the actual data. Although the 12-bit resolution maximum value of 4095 can be stored in one word using either binary or BCD formats, the 14 and 16-bit resolution maximum values of 16383 and 65535 both exceed the BCD format's maximum single word capacity of 9999. Double word math would be required for 14 or 16-bit data in BCD format. Binary data format is also useful for displaying data on some operator interfaces.*

Input Engineering Unit Conversion Example 1:

Data format = BCD,
 Channel 1 data memory location = V2000,
 Channel 1 resolution = 12-bits,
 Channel 1 engineering units = 0.0–140.0 PSI,
 Channel 1 input device = 0–20 mA transmitter

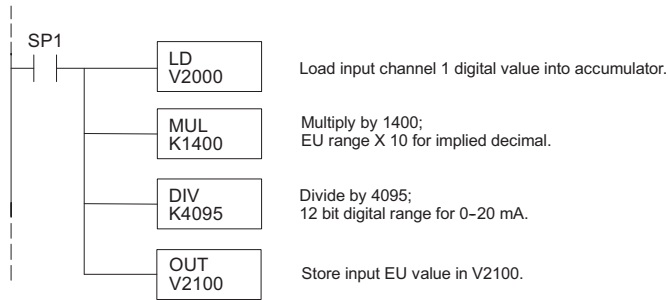

Input Engineering Unit Conversion Example 2:

Data format = binary,
 Channel 1 data memory location = V2000,
 Channel 1 resolution = 14-bits,
 Channel 1 engineering units = 0.0–140.0 PSI,
 Channel 1 input device = 0–20 mA transmitter

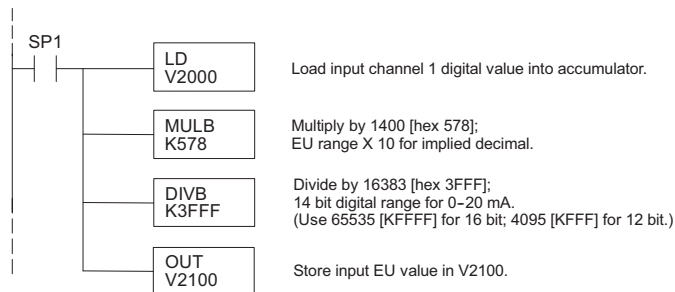

NOTE: The above examples use SP1 (which is always on) as a permissive contact for the engineering unit conversions. X, C, etc., could also be used as a permissive contact.

Input Engineering Unit Conversion Example 3:

- Data format = BCD,
- Channel 1 data memory location = V2000,
- Channel 1 resolution = 12-bits,
- Channel 1 engineering units = 0.0–140.0 PSI,
- Channel 1 input device = 4–20 mA transmitter.

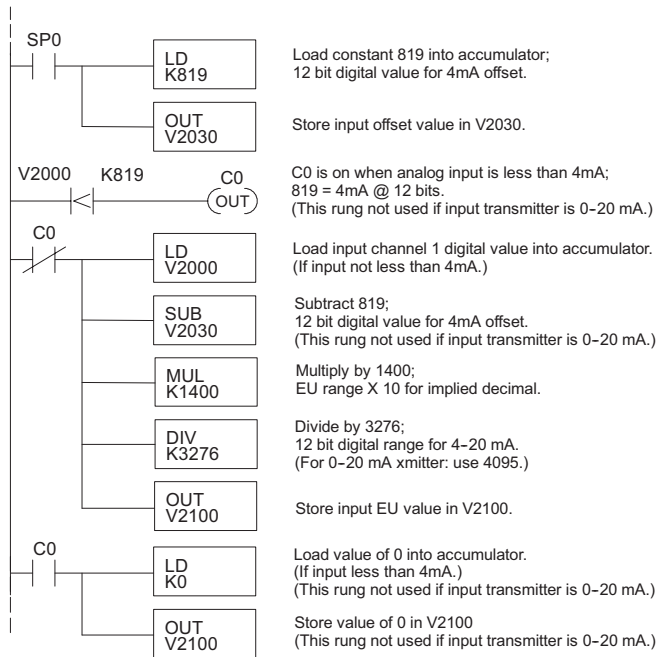

Input Engineering Unit Conversion Example 4:

- Data format = binary,
- Channel 1 data memory location = V2000,
- Channel 1 resolution = 16-bits,
- Channel 1 engineering units = 0.0–140.0 PSI,
- Channel 1 input device = 4–20 mA transmitter.

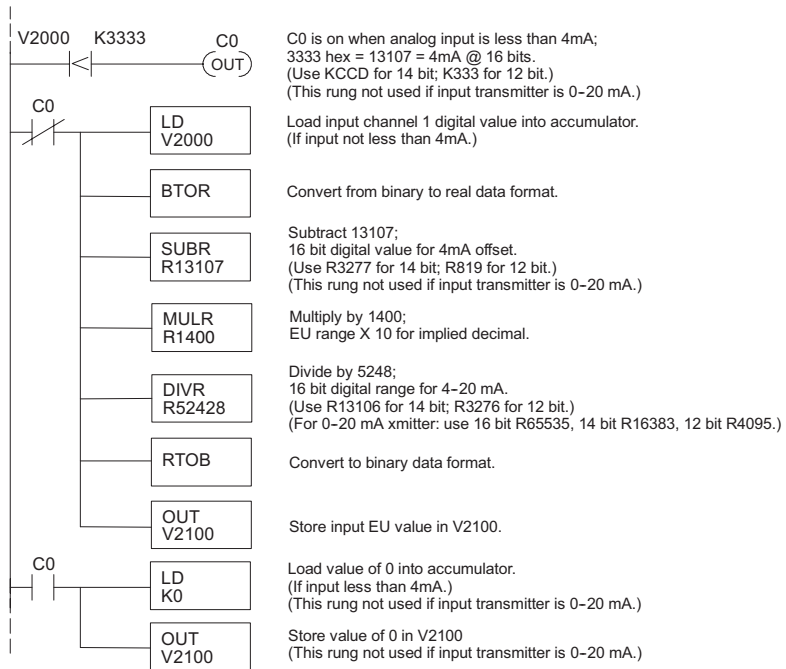

Using the Input Track and Hold Feature

The input Track and Hold feature allows the individual inputs to be separately configured to maintain their maximum or minimum data values. If No Track and Hold is selected, the present real time value of the input will be stored in the input data V-memory location. If Track and Hold minimum value is selected, the first input value less than or equal to full scale will be read and maintained until a lower value is measured, or until Track and Hold is reset. If maximum value is selected, the first input value greater than or equal to zero will be read and maintained until a higher value is measured, or until Track and Hold is reset.

To reset Track and Hold, write a value of one to the Track and Hold selection high and low bits. When Track and Hold is reset, the module will display the real-time input value. When the selection is changed from reset to minimum value or maximum value, the input will start over as described previously.

Track and Hold Example:

Number of Channels = 1 in, 1 out,
 Data Format = binary in, binary out,
 Input resolution = 16-bits,
 Input Track and Hold = channel 1 reset.

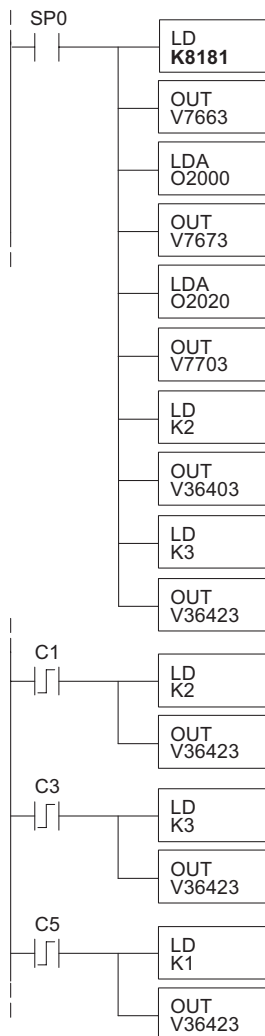

Rung 1, Module Configuration:

Input: binary data format, 1 channel.
 Output: binary data format, 1 channel.
 Module location: local base, slot 3.
 Input data 1st memory location: V2000
 Output data 1st memory location: V2020
 Input resolution: 16 bit channel 1.
 Input Track and Hold: reset channel 1.

C1 loads value of 2 (binary 10) into the Track and Hold Selection register. This sets input channel 1 for Track and Hold Maximum Value. As the analog value varies, only a measured value higher than the previously stored value will be written to V2000.

C3 loads a value of 3 (binary 11) into the Track and Hold Selection register. This sets input channel 1 for Track and Hold Reset Value. Real-time measured values will be written to V2000 until another Track and Hold Selection is made.

C5 loads value of 1 (binary 01) into the Track and Hold Selection register. This sets input channel 1 for Track and Hold Minimum Value. As the analog value varies, only a measured value lower than the previously stored value will be written to V2000.

Module 16-bit Output Resolution

Since the 4–20 mA output module has 16-bit resolution, the analog signal is converted into 65536 (2¹⁶) counts ranging from 0–65535. For example, a 4mA signal would be 0, and a 20mA signal would be 65535. This is equivalent to a binary value of 0000 0000 0000 0000 – 1111 1111 1111 1111, or 0000 – FFFF hexadecimal. The diagram shows how this relates to the signal range.

Each count can also be expressed in terms of the signal level by using the equation shown.

4 – 20 mA 16 Bit Output Resolution

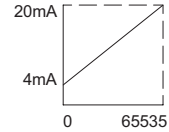

$$\text{Resolution} = \frac{H - L}{65535}$$

H = high limit of the signal range

L = low limit of the signal range

$$16\text{mA} / 65535 = 0.244\mu\text{A per count}$$

Digital and Analog Output Data Value Conversion

Sometimes it is useful to be able to quickly convert between the signal levels and the digital values. This is especially helpful during machine startup or troubleshooting. The table below provides formulas to make this conversion easier.

$$A = A_{\min} + [(D)(A_{\max} - A_{\min}) / (D_{\max})]$$

$$D = (A - A_{\min})(D_{\max}) / (A_{\max} - A_{\min})$$

- A = analog current output value
- A_{max} = maximum analog value
- A_{min} = minimum analog value
- D = digital value from PLC CPU
- D_{max} = maximum digital value

Resolution	Output Range	If the digital value is known	If the analog signal level is known
16-bit 0–65535	4–20 mA	$A = 4 + 16D / 65535$	$D = (A - 4) \frac{65535}{16}$

For example, if a 10mA analog output signal is needed, the formula could be used to determine the digital value (D) to be stored in the V-memory location that contains the output data.

$$D = (10 - 4) \frac{65535}{16}$$

$$D = (6)(4095.94)$$

$$D = 24576$$

Output Value Comparisons: Analog, Digital, Engineering Units

The table at right shows how the output analog, digital, and engineering unit values are related to each other. The example is a measurement of pressure from 0.0–140.0 PSI, using a multiplier of 10 for one implied decimal place.

Analog, Digital, and Engineering Units Output Comparisons		
Analog (mA)	Digital 16-bit	E.U.
20	65535	1400
12	39321	700
10	32768	525
4	13107	0

Calculating the Digital Output Value

The value sent to the 16-bit analog output module must be in digital form. A very good method to do this is to convert the value into engineering units. Use the formula shown on the right to accomplish this.

Adjustments to the formula may be needed depending on the scale chosen for the engineering units.

Consider the following example which controls pressure from 0.0–140.0 PSI. By using the formula, the digital value can be determined that can be sent to the module. The example shows the conversion required to yield 52.5 PSI. Notice the formula divides by 10, because the BCD representation of 52.5 includes a multiplier of 10 to allow for the implied decimal. The division corrects for the multiplier.

$$D = 10EU \frac{D_{max}}{(EU_H - EU_L)}$$

D = digital value
 EU = engineering units
 EU_H = engineering unit range high limit
 EU_L = engineering unit range low limit

$$D = 10EU \frac{D_{max}}{10(EU_H - EU_L)} \qquad D = 525 \frac{100 - 0}{10(140)} \qquad D = 24576$$

Calculating Output Data: Engineering Units Conversion

The below example program shows how to write the program to perform the engineering unit conversion to output the 16-bit data format of 0–65535. This example assumes that the engineering units have been calculated or loaded, including a multiplier of 10, in BCD format and stored it in V2120 for output channel 1.

Output Engineering Unit Conversion / Output Data Calculation

Example:

- Data format = binary
- Channel 1 data memory location = V2020
- Channel 1 engineering units = 0.0–140.0 PSI

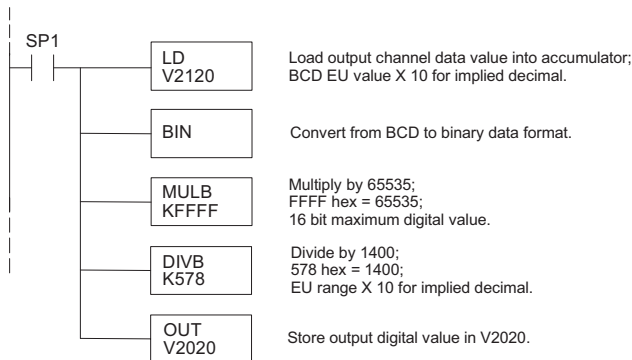

F2-8AD4DA-2 8-CH. IN/4-CH. OUT CURRENT VOLTAGE COMBINATION



In This Chapter...

Module Specifications	16-2
Connecting the Field Wiring.....	16-6
Module Operation	16-8
Special V-Memory Locations.....	16-12
Writing the Control Program.....	16-16

Module Specifications

The F2-8AD4DA-2 Analog Voltage Input/Output module provides several hardware features:

- Analog inputs and outputs are optically isolated from the PLC logic.
- The module has a removable terminal block so the module can be easily removed or changed without disconnecting the wiring.
- All input and output channels are updated in one scan.
- On-board active analog filtering, two CISC microcontrollers and CPLD provide digital signal processing to maintain precision analog measurements in noisy environments.
- Low-power CMOS design requires only 80mA from an external 18–26.4 VDC power supply.
- Input resolution is independently adjustable for each channel. Users may select 12-bit, 14-bit or 16-bit.
- Output resolution is 16-bit.
- Each input can be independently configured to return the present value, or to track and hold the maximum or minimum value.
- No jumper settings.

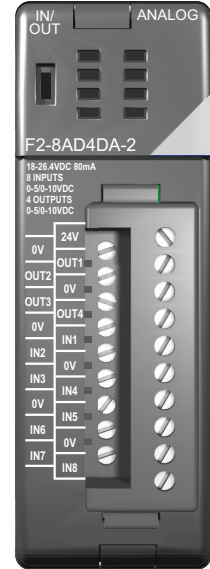

F2-8AD4DA-2

F2-8AD4DA-2 Hardware and Firmware Requirements

The F2-8AD4DA-2 Analog Voltage Input/Output Module requires one of the following components as a CPU or controller.

Hardware and Firmware Requirements		
Base Type	CPU/Controller	Firmware Version
Local	D2-250-1	4.40 or later
	D2-260	2.20 or later
	D2-262	1.0 TBD
Expansion	D2-CM	1.30 or later
Remote I/O	H2-EBC(-F)	2.1.441 or later
	H2-EBC100	4.0.457 or later

The following tables provide the specifications for the F2-8AD4DA-2 Analog Voltage Input/Output Module. Review these specifications to be certain that it will meet the requirements of your application.

Input Specifications	
Number of Input Channels	8, single ended (one common)
Input Range	0–5 V, 0–10 V
Input Resolution / Value of LSB	12, 14, or 16-bit; selectable 12-bit, 0–5 V = 1.22 mV 12-bit, 0–10 V = 2.44 mV 14-bit, 0–5 V = 305µV 14-bit, 0–10 V = 610µV 16-bit, 0–5 V = 76µV 16-bit, 0–10 V = 152µV
Input Impedance	1MΩ, ±5%
Maximum Continuous Overload	±100V
Filter Characteristics	Active low pass; -3 dB @ 80Hz
PLC Input Update Rate	8 channels per scan (max. with pointers; local base)
Sample Duration Time (note)	2ms @ 12-bit; 5.52ms @ 14-bit; 23ms @ 16-bit
Conversion Time (note)	12-bit = 1.5 ms per channel 14-bit = 6ms per channel 16-bit = 25ms per channel
Conversion Method	Over sampling successive approximation
Accuracy vs. temperature	25ppm / °C maximum
Input Stability and Repeatability	±0.03% of range (after 30 minute warm-up)
Input Inaccuracy	0.1% of range maximum
Linearity Error (end to end)	12-bit = ±2 counts max. (±0.06% of range) 14-bit = ±10 counts max. (±0.06% of range) 16-bit = ±40 counts max. (±0.06% of range) Monotonic with no missing codes
Full Scale Calibration Error (not including offset error)	±0.07% of range maximum
Offset Calibration Error	±0.025% of range maximum
Common Mode Rejection	-90dB min. @ DC; -150dB min. @ 50/60Hz
Crosstalk	±0.025% of range max. @ DC, 50/60Hz



NOTE: The values listed for Sample Duration Time and Conversion Time are for a single channel, and do not include PLC scan times.

Output Specifications	
Number of Output Channels	4
Output Range	0–5 V, 0–10 V
Output Resolution	16-bit
Output Type	Voltage sourcing / sinking at 10mA max.
Output Signal at Power-up & Power-down	0V
Output Impedance	0.2 Ω typical
External Load Resistance	>1000 Ω
Maximum Capacitive Load	0.1 μ F
Allowed Load Type	Grounded
Max. Continuous Output Overload	Limited to 15mA typical
Type of Output Protection	15VDC Peak Output Voltage (clamped by transient voltage suppressor)
PLC Output All Channel Update Time	4ms (local base)
Output Settling Time	0.5 ms max.; 5 μ s min. (full scale change)
Output Ripple	0.005% of full scale
Accuracy vs. Temperature	\pm 25 ppm/ $^{\circ}$ C max. full scale calibration change (\pm 0.0025% of range / $^{\circ}$ C)
Output Stability and Repeatability	\pm 1 LSB after 10 minute warm-up typical
Output Inaccuracy	0.1% of range maximum
Linearity Error (end to end)	\pm 33 counts max. (\pm 0.05% of full scale) Monotonic with no missing codes
Full Scale Calibration Error (not including offset error)	\pm 0.07% of range maximum
Offset Calibration Error	\pm 0.03% of range maximum
Crosstalk at DC, 50/60Hz	-70dB or 0.025% of full scale



NOTE: One count in the specifications table is equal to one least significant bit of analog data value (1 in 65536)

General Module Specifications	
Digital Input and Output Points Required	32 point (X) Inputs 32 point (Y) Outputs
Power Budget Requirement	35mA @ 5VDC (supplied by the base)
External Power Supply Requirement	18–26.4 VDC, 80mA maximum
Field Side to Logic Side Isolation	1800VAC applied for 1 second (100% tested)
Insulation Resistance	>10MΩ @ 500VDC
Operating Temperature	0–60°C (32–140°F); IEC60068-2-14
Storage Temperature	–20–70°C (- 4–158°F); IEC60068-2-1, -2-2, -2-14
Relative Humidity	5–95% (non-condensing); IEC60068-2-30
Environmental Air	No corrosive gases permitted; EN61131-2 pollution degree 1
Vibration	MIL STD 810C 514.2; IEC60068-2-6
Shock	MIL STD 810C 516.2; IEC60068-2-27
Noise Immunity	NEMA ICS3-304; IEC61000-4-2, -4-3, -4-4
Emissions	EN61000-6-4 (conducted and radiated RF emissions)
Module Location	Any non-CPU slot in local, expansion, or Ethernet remote base of DL205 system with D2-250-1, D2-260 or D2-262 CPU
Field Wiring	19 point removable terminal block included. Optional remote wiring using ZL-CM20 remote feed-through terminal block module and ZL-2CBL2# cable.
Agency Approvals	UL508; UL6079-15 Zone 2; CE (EN61131-1)

Module Placement and Configuration Requirements

The F2-8AD4DA-2 analog voltage input/output module requires 32 discrete input and 32 discrete output points.

The module can be installed in any non-CPU slot of D2-250-1, D2-260 or D2-262 local bases, D2-CM expansion bases, H2-EBC(100)(-F) Ethernet remote bases, H2-PBC Profibus slave bases, or H2-WPLCx-xx WinPLC bases.



NOTE: The module is NOT supported by D2-230, D2-240, or D2-250 CPUs. It is also not supported by D2-RMSM and D2-RSSS remote I/O master/slave modules.

The available power budget may also be a limiting factor. Check the user manual for the particular module of CPU and I/O base for more information regarding power budget and number of local, local expansion, or Ethernet remote I/O points.

Connecting the Field Wiring

Wiring Guidelines

Your company may have guidelines for wiring and cable installation. If so, check the guidelines before beginning the installation. Here are some general things to consider:

- Use the shortest wiring route whenever possible.
- Use shielded wiring and ground the shield at the transmitter source. Do not ground the shield at both the module and the load or source.
- Do not run the signal wiring next to large motors, high current switches, or transformers. This may cause noise problems.
- Route the wiring through an approved cable housing to minimize the risk of accidental damage. Check local and national codes to choose the correct method for your application.
- Unused inputs should be shorted together and connected to common.

User Power Supply Requirements

The F2-8AD4DA-2 module requires at least one field-side power supply. The same or separate power sources can be used for the module supply and the transmitter supply. The module requires 18-26.4 VDC (at 80mA), from the external power supply.

The DL205 AC bases have a built-in 24VDC power supply that provide up to 300mA of current. This can be used instead of a separate supply. Check the power budget to be safe.

It is desirable in some situations to power the transmitters separately in a location remote from the PLC. This will work as long as the transmitter supply meets the voltage and current requirements, and that the transmitter and the module power supply negative (-) side are connected together.



WARNING: If the 24VDC base power is used, be sure to calculate the power budget. Exceeding the power budget can cause unpredictable system operation that can lead to a risk of personal injury or equipment damage.

The DL205 base has a switching type power supply. As a result of switching noise, $\pm 3-5$ counts of instability may be noticed in the analog input data if the base power supply is used. If this is unacceptable, try one of the following:

- Use a separate linear power supply.
- Connect the 24VDC common to the frame ground, which is the screw terminal marked "G" on the base.

When using these methods, the input stability is rated at $\pm 0.03\%$ of range.

Wiring Diagram

The F2-8AD4DA-2 module has a removable connector to simplify wiring. Simply squeeze the top and bottom retaining clips and gently pull the connector from the module. Use the following diagram to connect the field wiring.

The diagram shows one power supply for both the module and the I/O signal loops. If a separate module and transmitter supplies are to be used, connect the power supply 0V commons together.

The four wire transmitter connected to input channel 8 is powered by an independent power source. In this case, the transmitter is treated as a 2-wire transmitter.

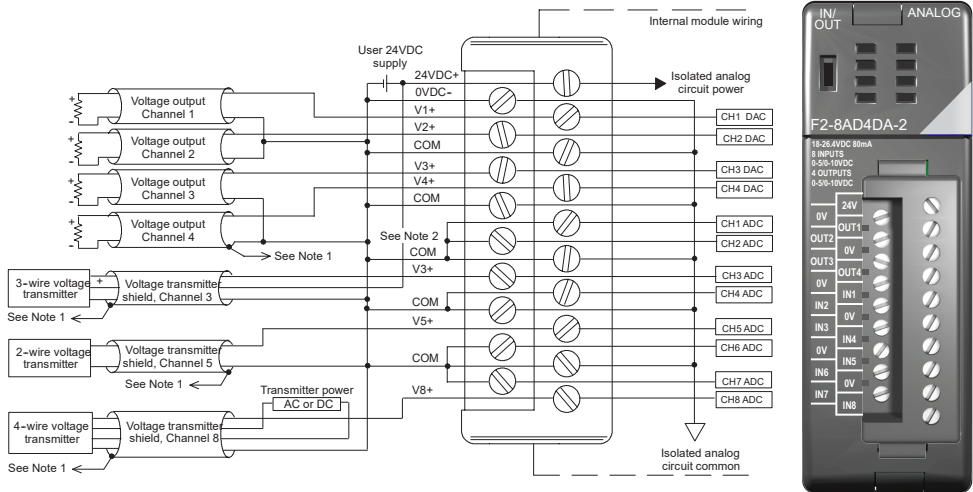

NOTE 1: Connect shields to the 0V of the module; do not connect both ends of the shield.

NOTE 2: Short unused inputs together and connect them to common.

Module Operation

Input Channel Scanning Sequence (Pointer Method)

If the F2-8AD4DA-2 module is installed in a local (CPU) base, the input data for all eight channels can be obtained in one scan. However, only one channel of input data can be obtained if the module is installed in an expansion, remote I/O, or Profibus slave base.

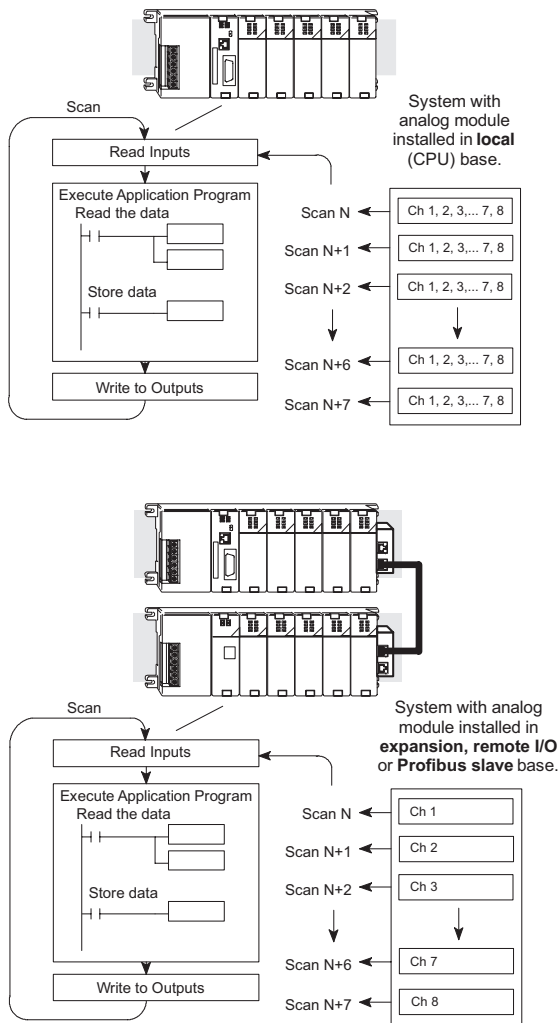

Output Channel Update Sequence (Pointer Method)

If the F2-8AD4DA-2 is installed in a local (CPU) base, all four output channels can be updated on every scan. However, only one channel can be updated per scan if the module is installed in an expansion, remote I/O, or Profibus slave base. The timing is synchronized with the timing of reading the input channels, so each output channel can be updated every eight scans.

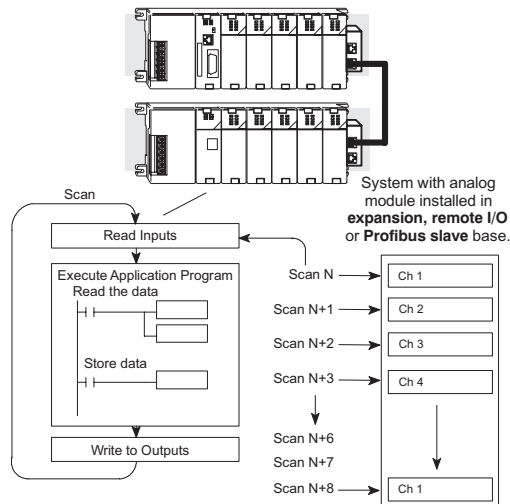
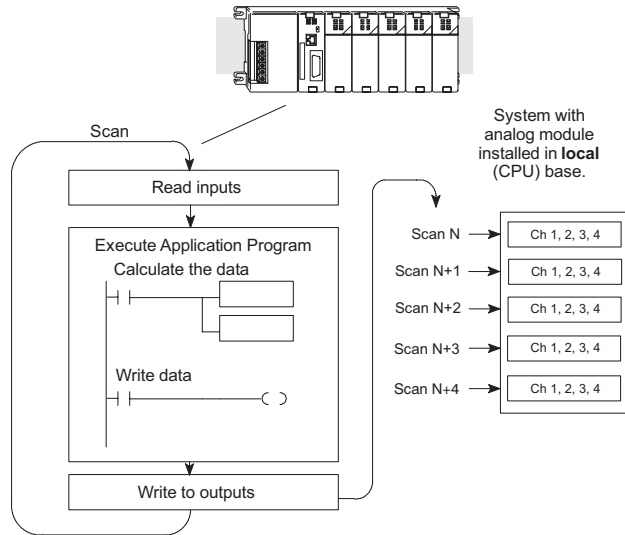

Understanding the I/O Assignments

Remember that the F2-8AD4DA-2 module appears to the CPU as a 32-point discrete input module and a 32-point discrete output module. These points can be used to obtain:

- An indication of which channel is active,
- The digital representation of the analog signal,
- Module diagnostic information,
- Settings for resolution, range, and track and hold.

These bits may never have to be used, but it may be an aid to help understand the data format.

Since all I/O points are automatically mapped into V-memory, the location of the data words that will be assigned to the module can simply be determined.

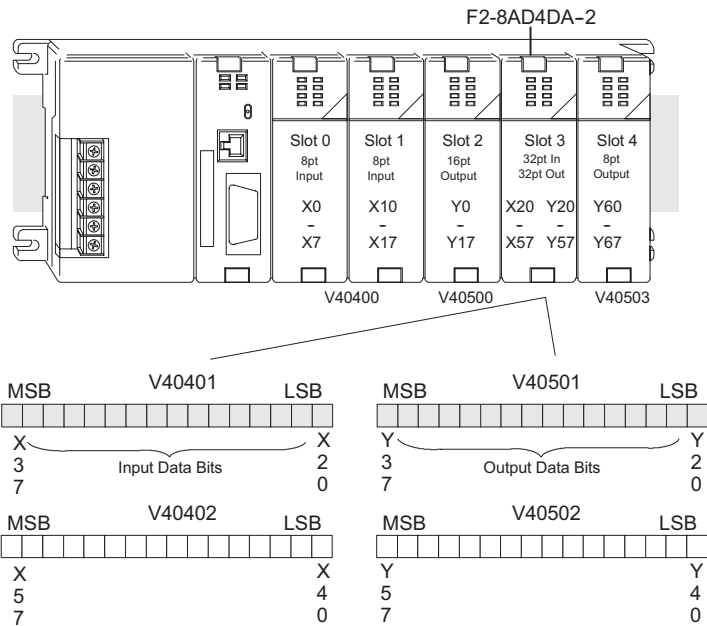

The individual bits in these data word locations represent specific information about the analog signal. (The specific memory locations may vary, depending upon the slot where the F2-8AD4DA-2 module is located.)

Input Data Bits

Depending upon the resolution selected, up to 16-bits of the first input word represent the analog data in binary format.

Bit	Value	Bit	Value
0	1	8	256
1	2	9	512
2	4	10	1024
3	8	11	2048
4	16	12	4096
5	32	13	8192
6	64	14	16384
7	128	15	32768

The input word is not usable by the programmer.

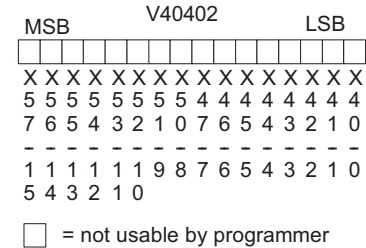
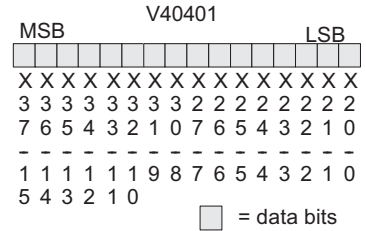

Output Data Bits

All 16-bits of the first output word represent the analog data in binary format.

Bit	Value	Bit	Value
0	1	8	256
1	2	9	512
2	4	10	1024
3	8	11	2048
4	16	12	4096
5	32	13	8192
6	64	14	16384
7	128	15	32768

The second output word is not usable by the programmer.

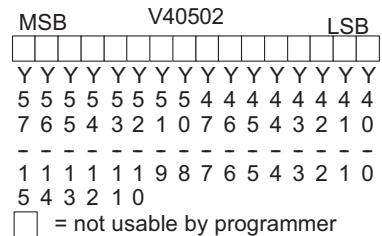
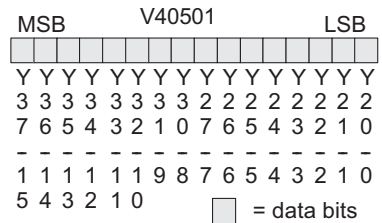

Special V-Memory Locations

The D2-250-1, D2-260 and D2-262 CPUs have special V-memory locations assigned to each base slot that greatly simplifies the programming requirements. These V-memory locations specify:

- The number of input and output channels to scan
- The storage locations for the input and output data
- The resolution for the inputs
- The range selections for the inputs and outputs
- The track and hold selections for the inputs

Module Configuration Registers

The following tables show the special V-memory used by the CPUs for the CPU base and local expansion base I/O slots. Slot 0 is the module slot next to the CPU or D2-CM module. Slot 1 is the module slot two places from the CPU or D2-CM, and so on. The CPU needs to examine the pointer values at these locations only after a mode transition.

CPU Base: Analog In/Out Module Slot-Dependent V-memory Locations								
Slot	0	1	2	3	4	5	6	7
No. of I/O Channels Enabled & Format	V7660	V7661	V7662	V7663	V7664	V7665	V7666	V7667
Input Pointer	V7670	V7671	V7672	V7673	V7674	V7675	V7676	V7677
Output Pointer	V7700	V7701	V7702	V7703	V7704	V7705	V7706	V7707
Input Resolutions	V36400	V36401	V36402	V36403	V36404	V36405	V36406	V36407
I/O Range Selection	V36410	V36411	V36412	V36413	V36414	V36415	V36416	V36417
Input Track & Hold	V36420	V36421	V36422	V36423	V36424	V36425	V36426	V36427

Expansion Base D2-CM #1: Analog In/Out Module Slot-Dependent V-memory Locations								
Slot	0	1	2	3	4	5	6	7
No. of I/O Channels Enabled & Format	V36000	V36001	V36002	V36003	V36004	V36005	V36006	V36007
Input Pointer	V36010	V36011	V36012	V36013	V36014	V36015	V36016	V36017
Output Pointer	V36020	V36021	V36022	V36023	V36024	V36025	V36026	V36027
Input Resolutions	V36030	V36031	V36032	V36033	V36034	V36035	V36036	V36037
I/O Range Selection	V36040	V36041	V36042	V36043	V36044	V36045	V36046	V36047
Input Track & Hold	V36050	V36051	V36052	V36053	V36054	V36055	V36056	V36057

Expansion Base D2-CM #2: Analog In/Out Module Slot-Dependent V-memory Locations								
Slot	0	1	2	3	4	5	6	7
No. of I/O Channels Enabled & Format	V36100	V36101	V36102	V36103	V36104	V36105	V36106	V36107
Input Pointer	V36110	V36111	V36112	V36113	V36114	V36115	V36116	V36117
Output Pointer	V36120	V36121	V36122	V36123	V36124	V36125	V36126	V36127
Input Resolutions	V36130	V36131	V36132	V36133	V36134	V36135	V36136	V36137
I/O Range Selection	V36140	V36141	V36142	V36143	V36144	V36145	V36146	V36147
Input Track & Hold	V36150	V36151	V36152	V36153	V36154	V36155	V36156	V36157

Expansion Base D2-CM #3: Analog In/Out Module Slot-Dependent V-memory Locations								
Slot	0	1	2	3	4	5	6	7
No. of I/O Channels Enabled & Format	V36200	V36201	V36202	V36203	V36204	V36205	V36206	V36207
Input Pointer	V36210	V36211	V36212	V36213	V36214	V36215	V36216	V36217
Output Pointer	V36220	V36221	V36222	V36223	V36224	V36225	V36226	V36227
Input Resolutions	V36230	V36231	V36232	V36233	V36234	V36235	V36236	V36237
I/O Range Selection	V36240	V36241	V36242	V36243	V36244	V36245	V36246	V36247
Input Track & Hold	V36250	V36251	V36252	V36253	V36254	V36255	V36256	V36257

Expansion Base D2-CM #4: Analog In/Out Module Slot-Dependent V-memory Locations								
Slot	0	1	2	3	4	5	6	7
No. of I/O Channels Enabled & Format	V36300	V36301	V36302	V36303	V36304	V36305	V36306	V36307
Input Pointer	V36310	V36311	V36312	V36313	V36314	V36315	V36316	V36317
Output Pointer	V36320	V36321	V36322	V36323	V36324	V36325	V36326	V36327
Input Resolutions	V36330	V36331	V36332	V36333	V36334	V36335	V36336	V36337
I/O Range Selection	V36340	V36341	V36342	V36343	V36344	V36345	V36346	V36347
Input Track & Hold	V36350	V36351	V36352	V36353	V36354	V36355	V36356	V36357

Number of I/O Channels Enabled & Data Format

Load this V-memory location with a constant that specifies the number of enabled I/O channels and their data formats. The upper byte applies to the inputs, and the lower byte applies to the outputs. The most significant nibbles specify the data formats, and the least significant nibbles specify the number of channels enabled.

V-memory Locations for No. of I/O Channels Enabled & Format								
No. of Channels Enabled	1	2	3	4	5	6	7	8
BCD Input	K01xx	K02xx	K03xx	K04xx	K05xx	K06xx	K07xx	K08xx
Binary Input	K81xx	K82xx	K83xx	K84xx	K85xx	K86xx	K87xx	K88xx
BCD Output	Kxx01	Kxx02	Kxx03	Kxx04	n/a	n/a	n/a	n/a
Binary Output	Kxx81	Kxx82	Kxx83	Kxx84	n/a	n/a	n/a	n/a

Input Selection Resolution Bits

Each of the eight input channels can be individually disabled or configured for 12, 14, or 16-bit resolution.

V36403: (specific memory location will vary depending upon the base and slot location).

15	14	13	12	11	10	9	8	7	6	5	4	3	2	1	0
R-8H	R-8L	R-7H	R-7L	R-6H	R-6L	R-5H	R-5L	R-4H	R-4L	R-3H	R-3L	R-2H	R-2L	R-1H	R-1L

RnH = Resolution channel n High bit

RnL = Resolution channel n Low bit

Input Resolution Select	RnH	RnL
12-bit	0	0
14-bit	0	1
16-bit	1	0
Disabled	1	1

Example: Input channels 1–4 are 12-bit, channel 5 is 14-bit, and channel 6 is 16-bit, and channels 7 and 8 are disabled; V36403-F900(hex).

15	14	13	12	11	10	9	8	7	6	5	4	3	2	1	0
R-8H	R-8L	R-7H	R-7L	R-6H	R-6L	R-5H	R-5L	R-4H	R-4L	R-3H	R-3L	R-2H	R-2L	R-1H	R-1L
1	1	1	1	1	0	0	1	0	0	0	0	0	0	0	0
F				9				0				0			

Input and Output Range Selection Bits

The range of the eight input channels can be collectively set for 0–5 V or for 0–10 V. The range of the four output channels can also be collectively set for either of the same two voltage ranges.

V36413: (specific memory location will vary depending upon the base and slot location).

15	14	13	12	11	10	9	8	7	6	5	4	3	2	1	0
-	-	-	-	-	-	-	OR	-	-	-	-	-	-	-	IR

IR = Input Range

OR = Output Range

Input/Output Range	IR	OR
0–5 V	0	0
0–10 V	1	1

Example: Input channel range is 0–5 V, and output channel range is 0–10 V; V36413=100(hex).

15	14	13	12	11	10	9	8	7	6	5	4	3	2	1	0
-	-	-	-	-	-	-	OR	-	-	-	-	-	-	-	IR
0	0	0	0	0	0	0	1	0	0	0	0	0	0	0	0
0				1				0				0			

Input Track and Hold Selection Bits

The track and hold feature for each of the eight inputs can be individually configured for minimum, maximum, no hold, or reset held value. This configuration can be changed “on the fly” while the program is running.

V36423: (specific memory location will vary depending upon the base and slot location).

15	14	13	12	11	10	9	8	7	6	5	4	3	2	1	0
T-8H	T-8L	T-7H	T-7L	T-6H	T-6L	T-5H	T-5L	T-4H	T-4L	T-3H	T-3L	T-2H	T-2L	T-1H	T-1L

TnH = Track and hold channel n High bit

TnL = Track and hold channel n Low bit

Track and Hold Select	TnH	TnL	Result
No Track and Hold	0	0	returns real time input value
Track and Hold Minimum Value	0	1	maintains lowest measured value
Track and Hold Maximum Value	1	0	maintains highest measured value
Reset Track and Hold Value	1	1	resets previously held input value

Example: Input channel track and hold settings:

1-3 = none, ch 4-5 = minimum,

ch 6-7 = maximum, ch 8 = reset; V36423=E940(hex).

15	14	13	12	11	10	9	8	7	6	5	4	3	2	1	0
T-8H	T-8L	T-7H	T-7L	T-6H	T-6L	T-5H	T-5L	T-4H	T-4L	T-3H	T-3L	T-2H	T-2L	T-1H	T-1L
1	1	1	0	1	0	0	1	0	1	0	0	0	0	0	0
E				9				4				0			

Writing the Control Program

Configuring the Module to Read/Write I/O (Pointer Method) for D2-250-1, D2-260 and D2-262

The example programs that follow show how to configure the special V-memory locations to read/write data from/to the I/O module. The module configuration rung needs to be read by the CPU only after a mode transition, and does not need to be read every scan. Place the configuration rung anywhere in the ladder program, or in the initial stage if stage programming instructions is being used. This is all that is required to read the input data and write the output data to/from the V-memory locations. Once the input data is in V-memory, math can be used for data calculations, compare the data against preset values, and so forth.

V2000 and V2020 are used as the beginning of the data areas in the example, but any user V-memory locations can be used. Also, these examples assume that the module is installed in slot 3 of the CPU base. The pointer V-memory locations determined by the layout of the application should be used.

Module Configuration Example 1:

Number of Channels = 8 in, 4 out,
 Data Format = binary in, BCD out,
 Input Resolution = 16-bit,
 Input/Output Range = 0–5 V in, 0–5 V out
 Input Track and Hold = none, real time value.

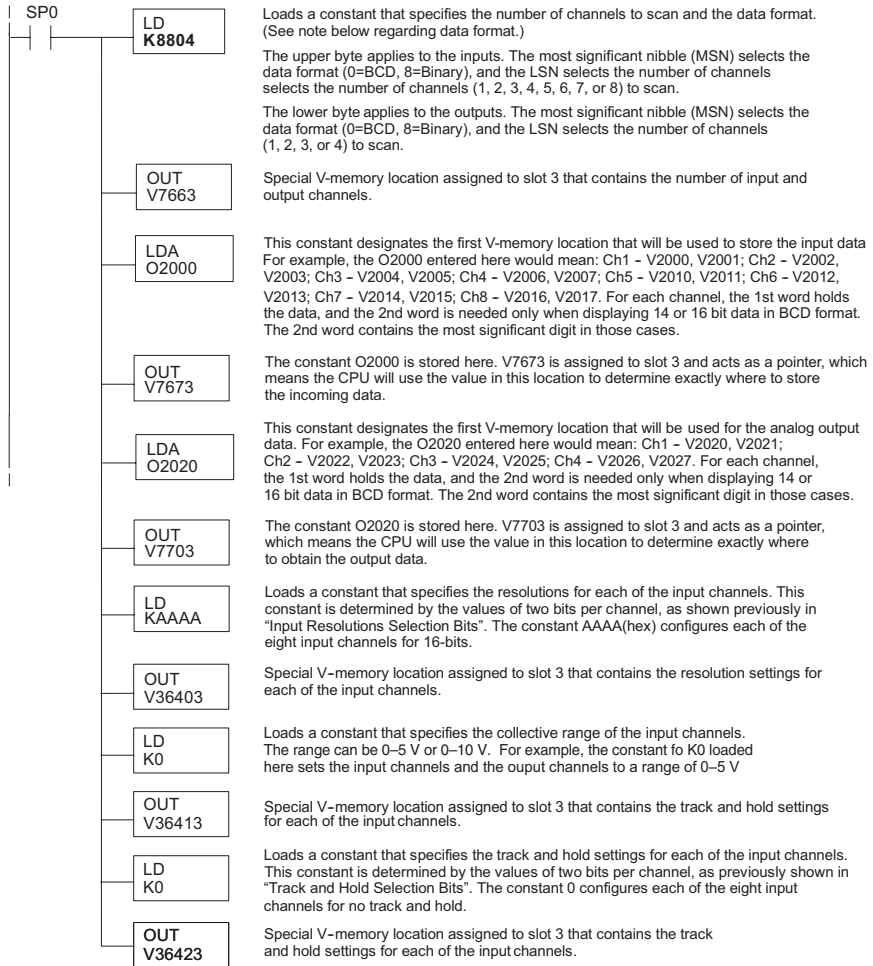

NOTE: Binary data format is recommended for 14 or 16-bit resolution input data, especially if the input data is to be used in any math instructions (DL205 User Manual, ch.5). There is only one V-memory word (16-bits) available for the actual data. Although the 12-bit resolution maximum value of 4095 can be stored in one word using either binary or BCD formats, the 14 and 16-bit resolution maximum values of 16383 and 65535 both exceed the BCD format's maximum single word capacity of 9999. Double word math would be required for 14 or 16-bit data in BCD format. Binary data format is also useful for displaying data on some operator interfaces.



Module Configuration Example 2:

Number of Channels = 4 in, 4 out,
 Data Format = binary in, BCD out,
 Input Resolution = 14-bit,
 Input/Output Range = 0–10 V in, 0–5 V out,
 Input Track and Hold = all inputs maximum value.

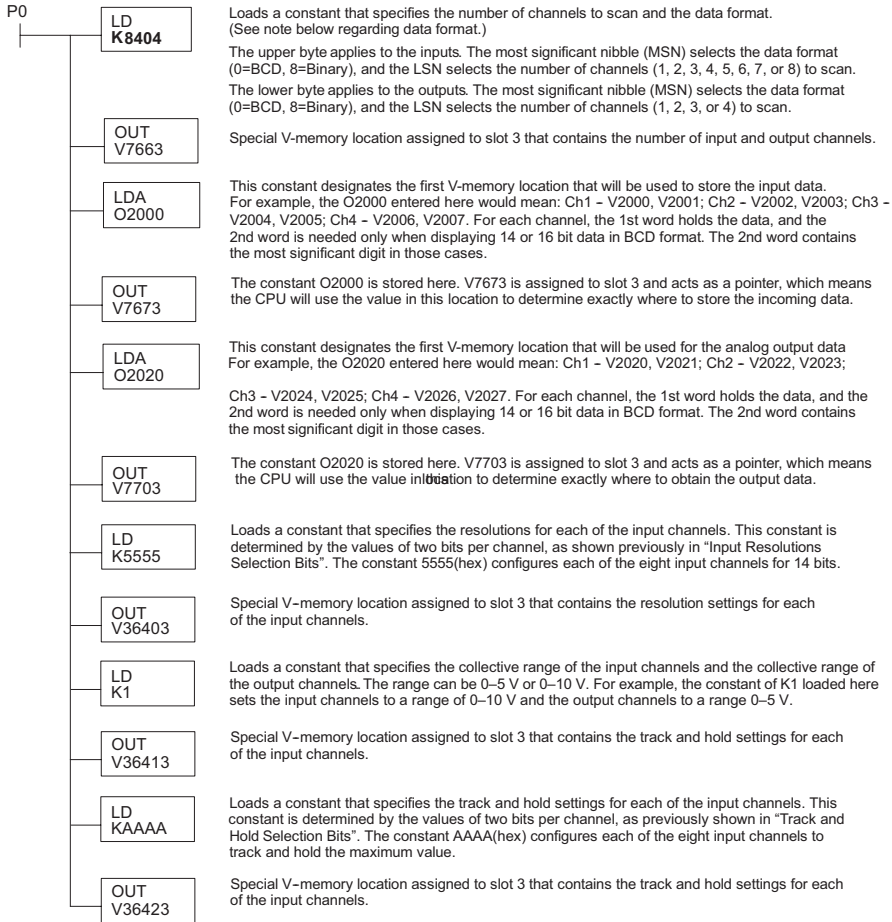

NOTE: Binary data format is recommended for 14 or 16-bit resolution input data, especially if the input data is to be used in any math instructions (DL205 User Manual, ch.5). There is only one V-memory word (16-bits) available for the actual data. Although the 12-bit resolution maximum value of 4095 can be stored in one word using either binary or BCD formats, the 14 and 16-bit resolution maximum values of 16383 and 65535 both exceed the BCD format's maximum single word capacity of 9999. Double word math would be required for 14 or 16-bit data in BCD format. Binary data format is also useful for displaying data on some operator interfaces.



Module Configuration Example 3:

Number of Channels = 4 in, 2 out,
 Data Format = BCD in, BCD out,
 Input Resolution = 12-bit,
 Input/Output Range = 0–10 V in, 0–10 V out,
 Input Track and Hold = all inputs minimum value.

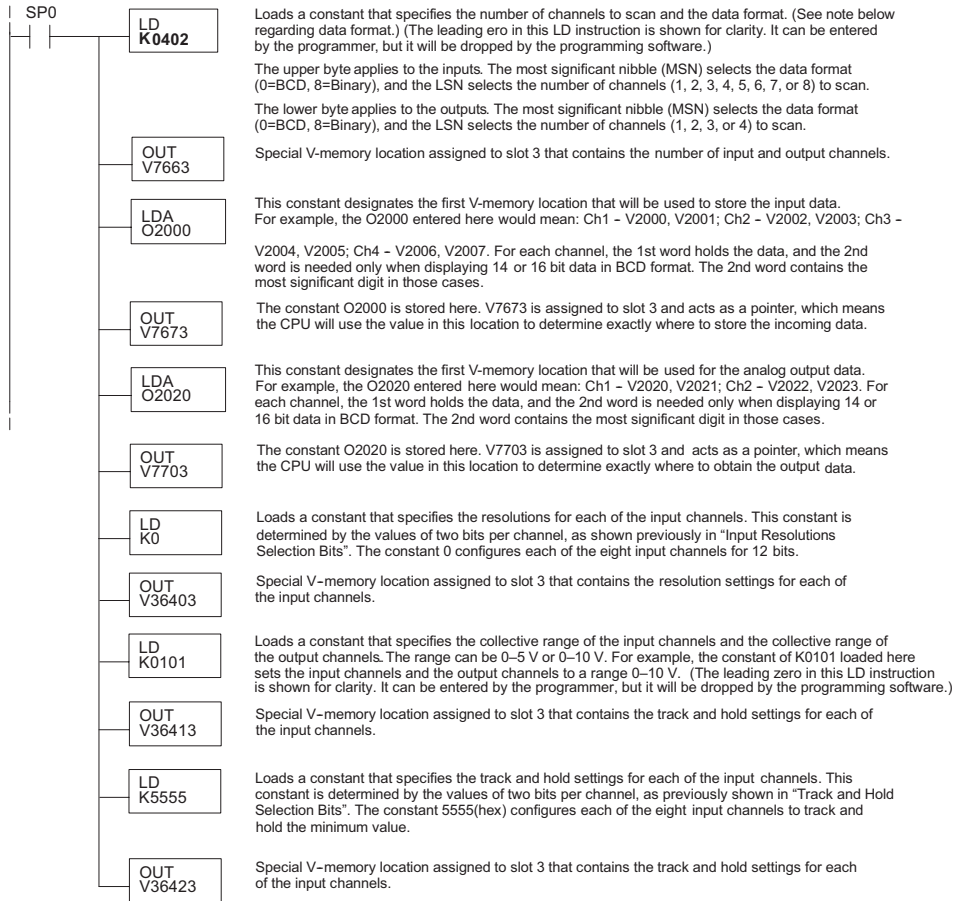

NOTE: Binary data format is recommended for 14 or 16-bit resolution input data, especially if the input data is to be used in any math instructions (DL205 User Manual, ch.5). There is only one V-memory word (16-bits) available for the actual data. Although the 12-bit resolution maximum value of 4095 can be stored in one word using either binary or BCD formats, the 14 and 16-bit resolution maximum values of 16383 and 65535 both exceed the BCD format's maximum single word capacity of 9999. Double word math would be required for 14 or 16-bit data in BCD format. Binary data format is also useful for displaying data on some operator interfaces.



Module 12-bit Input Resolution

When the module voltage inputs are configured for 12-bit resolution, the analog signal is converted into 4096 (2¹²) counts ranging from 0–4095. For example, a 0V signal would be 0, and a full scale 5V or 10V signal would be 4095. This is equivalent to a binary value of 0000 0000 0000 to 1111 1111 1111, or 000 to FFF hexadecimal. The diagram shows how this relates to the signal range.

Each count can also be expressed in terms of the signal level by using the equation shown.

Module 14-bit Input Resolution

When the module voltage inputs are configured for 14-bit resolution, the analog signal is converted into 16384 (2¹⁴) counts ranging from 0–16383. For example, a 0V signal would be 0, and a full scale 5V or 10V signal would be 16383. This is equivalent to a binary value of 00 0000 0000 0000 to 11 1111 1111 1111, or 0000 to 3FFF hexadecimal. The diagram shows how this relates to the signal range.

Each count can also be expressed in terms of the signal level by using the equation shown.

Module 16-bit Input Resolution

When the module voltage inputs are configured for 16-bit resolution, the analog signal is converted into 65536 (2¹⁶) counts ranging from 0–65535. For example, a 0V signal would be 0, and a full scale 5V or 10V signal would be 65535. This is equivalent to a binary value of 0000 0000 0000 0000 to 1111 1111 1111 1111, or 0000 to FFFF hexadecimal. The diagram shows how this relates to the signal range.

Each count can also be expressed in terms of the signal level by using the equation shown.

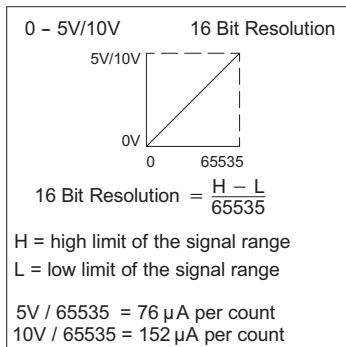
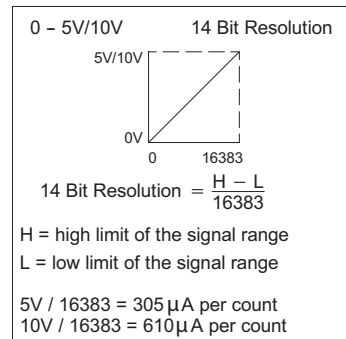
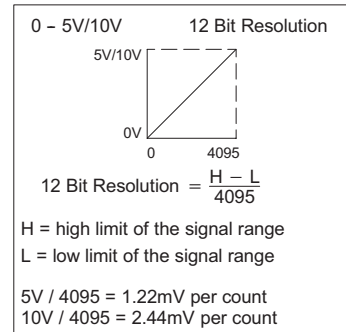

Analog and Digital Input Data Value Conversion

Sometimes it is useful to be able to quickly convert between the signal levels and the digital values. This is especially helpful during machine startup or troubleshooting. The table provides formulas to simplify the conversion.

$$A = (D)(A_{max}) / (D_{max})$$

$$D = (A)(D_{max}) / (A_{max})$$

A = Analog value from current transmitter

A_{max} = Maximum analog value

D = Digital value of input provided to PLC CPU

D_{max} = Maximum digital value

Analog and Digital Input Data Conversion			
Resolution	Input Range	If the digital value is known	If the analog signal is known
12-bit 0-4095	0-5 V	$A = (D)(5) / 4095$	$D = (A)(4095) / 5$
	0-10 V	$A = (D)(10) / 4095$	$D = (A)(4095) / 10$
14-bit 0-16383	0-5 V	$A = (D)(5) / 16383$	$D = (A)(16383) / 5$
	0-10 V	$A = (D)(10) / 16383$	$D = (A)(16383) / 10$
16-bit 0-65535	0-5 V	$A = (D)(5) / 65535$	$D = (A)(65535) / 5$
	0-10 V	$A = (D)(10) / 65535$	$D = (A)(65535) / 10$

For example, if a 0-10 V range with 16-bit resolution is being used, and the signal measured is 6V, the formula can be easily used to determine the digital value (D) that should be stored in the V-memory location that contains the data.

$$D = (A) 65535$$

$$10$$

$$D = (6) (6553.5)$$

$$D = 39321$$

Scaling the Input Data

Most applications require measurements in engineering units, which provide more meaningful data. For input ranges with a minimum value of zero, this can be accomplished by using the conversion formulas shown below.

$$EU = (A)(EUH - EUL) / (Amax)$$

$$EU = (D)(EUH - EUL) / (Dmax)$$

- A = analog value from current transmitter
- D = digital value of input provided to PLC CPU
- EU = engineering units
- EUH = engineering units high value
- EUL = engineering units low value

The following examples show a 16-bit measurement of pressure (PSI) from 0.0–140.0. The analog value needs to be multiplied by 10 in order to imply a decimal place when the value is viewed with the programming software. Notice how the calculations differ when the multiplier is used.

Scaling Example

Analog Value of 6.3 V, 0–10 V transmitter, 16-bit resolution, should yield 88.2 psi.

Example without multiplier

$$EU = (D) \frac{EU_H - EU_L}{D_{max}}$$

$$EU = (41287) \frac{140 - 0}{65535}$$

$$EU = 88$$

Example with multiplier

$$EU = (10)(D) \frac{EU_H - EU_L}{D_{max}}$$

$$EU = (10)(41287) \frac{140 - 0}{65535}$$

$$EU = 882$$

NOTE: Binary data format is recommended for **14 or 16-bit resolution input data**, especially if the input data is to be used in any math instructions (DL205 User Manual, ch.5). There is only one V-memory word (16-bits) available for the actual data. Although the 12-bit resolution maximum value of 4095 can be stored in one word using either binary or BCD formats, the 14 and 16-bit resolution maximum values of 16383 and 65535 both exceed the BCD format's maximum single word capacity of 9999. Double word math would be required for 14 or 16-bit data in BCD format. **Binary data format** is also useful for displaying data on some **operator interfaces**.



Input Engineering Unit Conversion Example 1:

Data format = BCD,
 Channel 1 data memory location = V2000,
 Channel 1 resolution = 12-bits,
 Channel 1 engineering units = 0.0–140.0 PSI,
 Channel 1 input device = 0–5 V or 0–10 V transmitter.

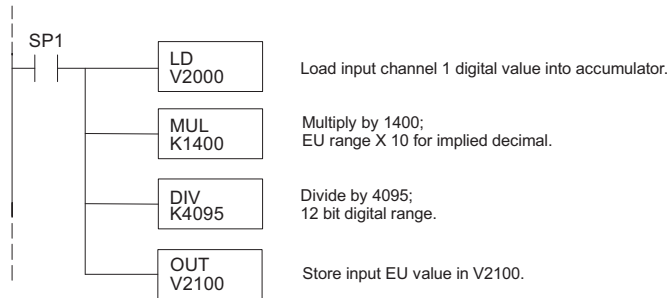

Input Engineering Unit Conversion Example 2:

Data format = binary,
 Channel 1 data memory location = V2000,
 Channel 1 resolution = 14-bits,
 Channel 1 engineering units = 0.0–140.0 PSI,
 Channel 1 input device = 0–5 V or 0–10 V transmitter.

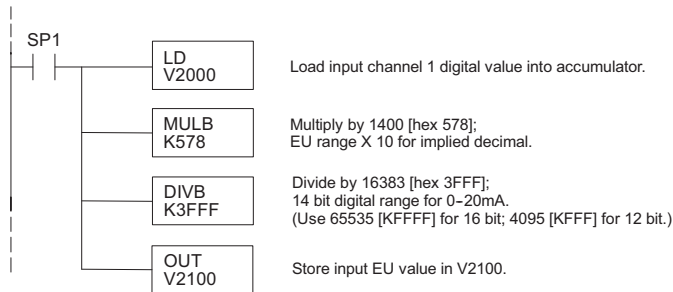

NOTE: The above examples use SP1 (which is always on) as a permissive contact for the engineering unit conversions. X, C, etc., could also be used as a permissive contact.

Input Engineering Unit Conversion Example 3:

Data format = binary,

Channel 1 data memory location = V2000,

Channel 1 resolution = 16-bits,

Channel 1 engineering units = 0.0–140.0 PSI,

Channel 1 input device = 0–5 V or 0–10 V transmitter.

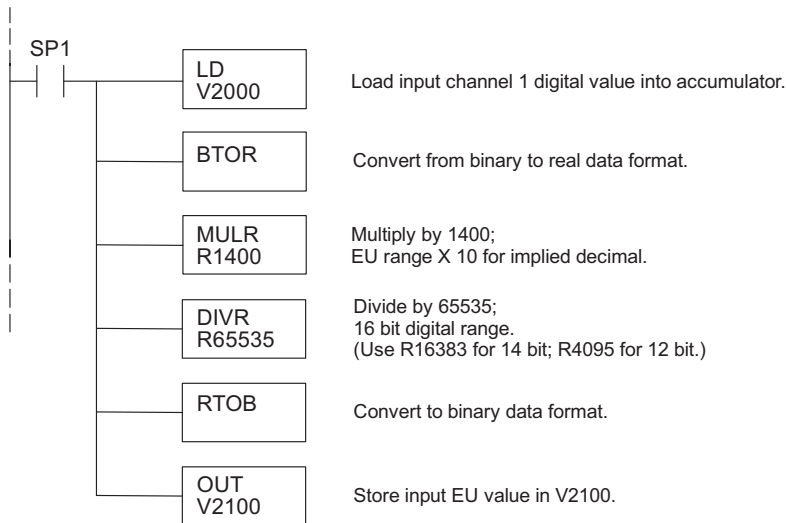

Using the Input Track and Hold Feature

The input Track and Hold feature allows the individual inputs to be separately configured to maintain their maximum or minimum data values. If No Track and Hold is selected, the present real time value of the input will be stored in the input data V-memory location. If Track and Hold minimum value is selected, the first input value less than or equal to full scale will be read and maintained until a lower value is measured, or until Track and Hold is reset. If maximum value is selected, the first input value greater than or equal to zero will be read and maintained until a higher value is measured, or until Track and Hold is reset.

To reset Track and Hold, write a value of one to the Track and Hold selection high and low bits. When Track and Hold is reset, the module will display the real-time input value. When the selection is changed from reset to minimum value or maximum value, the input will start over as described previously.

Track and Hold Example:

Number of Channels = 1 in, 1 out,
 Data Format = binary in, binary out,
 Input resolution = 16-bits,
 Input/Output Range = 0–10 V in, 0–10 V out,
 Input Track and Hold = channel 1 reset.

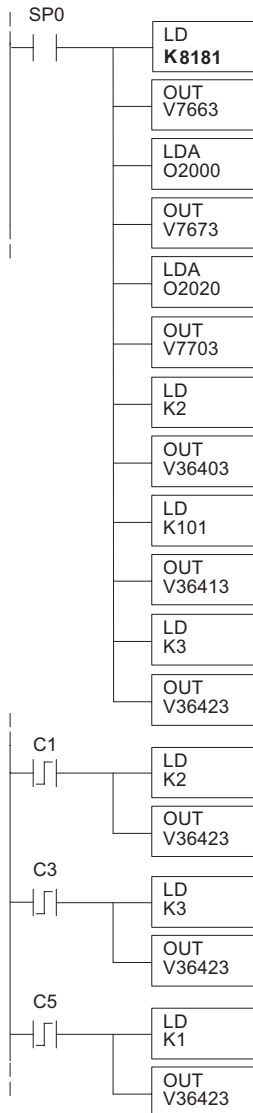

Rung 1, Module Configuration:
 Input: binary data format, 1 channel.
 Output: binary data format, 1 channel.
 Module location: local base, slot 3.
 Input data 1st memory location: V2000.
 Output data 1st memory location: V2020.
 Input resolution: 16 bit channel 1.
 Input/Output range: 0–10V in, 0–10V out.
 Input Track and Hold: reset channel 1.

C1 loads value of 2 (binary 10) into the Track and Hold Selection register. This sets input channel 1 for Track and Hold Maximum Value. As the analog value varies, only a measured value higher than the previously stored value will be written to V2000.

C3 loads a value of 3 (binary 11) into the Track and Hold Selection register. This sets input channel 1 for Track and Hold Reset Value. Real-time measured values will be written to V2000 until another Track and Hold Selection is made.

C5 loads value of 1 (binary 01) into the Track and Hold Selection register. This sets input channel 1 for Track and Hold Minimum Value. As the analog value varies, only a measured value lower than the previously stored value will be written to V2000.

Module 16-bit Output Resolution

Since the voltage output module has 16-bit resolution, the analog signal is converted into 65536 (2¹⁶) counts ranging from 0-65535. For example, a 0V signal would be 0, and a full scale 5V or 10V signal would be 65535. This is equivalent to a binary value of 0000 0000 0000 0000 to 1111 1111 1111 1111, or 0000 to FFFF hexadecimal. The diagram shows how this relates to the signal range.

Each count can also be expressed in terms of the signal level by using the equation shown.

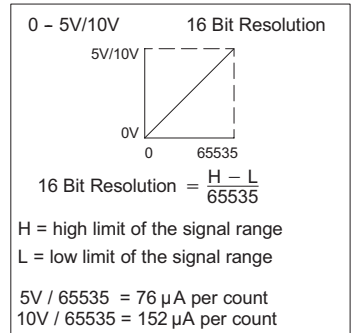

Digital and Analog Output Data Value Conversion

Sometimes it is useful to be able to quickly convert between the signal levels and the digital values. This is especially helpful during machine startup or troubleshooting. For output ranges with a minimum value of zero, the table below provides formulas to make this conversion easier.

$$A = (D)(A_{max}) / (D_{max})$$

$$D = (A)(D_{max}) / (A_{max})$$

- A = analog current output value
- A_{max} = maximum analog value
- D = digital value from PLC CPU
- D_{max} = maximum digital value

Resolution	Output Range	If the digital value is known	If the analog signal level is known.
16-bit 0-65535	0-5 V	$A = (D)(5) / 65535$	$D = (A)(65535) / 5$
	0-10 V	$A = (D)(10) / 65535$	$D = (A)(65535) / 10$

For example, if a 6V analog output signal with a 0-10 V output range, the formula could be used to determine the digital value (D) to be stored in the V-memory location that contains the output data.

$$D = (6) \frac{65535}{10}$$

$$D = (6)(6553.5)$$

$$D = 39321$$

Output Value Comparisons: Analog, Digital, Engineering Units

The table to the right shows how the output analog, digital, and engineering unit values are related to each other. The example is a measurement of pressure from 0.0-140.0 psi, using a multiplier of 10 for one implied decimal place.

Output Value Comparisons			
Analog Range		Digital 16-bit	E.U.
0-5 V	0-10 V		
5	10	65535	1400
2.5	5	32768	700
0	0	0	0

Calculating the Digital Output Value

The value sent to the 16-bit analog output module must be in digital form. A very good method to do this is to convert the value into engineering units. Use the formula shown on the right to accomplish this.

Adjustments to the formula may be needed depending on the scale chosen for the engineering units.

Consider the following example which controls pressure from 0.0–140.0 psi. By using the formula, the digital value can be determined that can be sent to the module. The example shows the conversion required to yield 52.5 psi. Notice the formula divides by 10, because the BCD representation of 52.5 includes a multiplier of 10 to allow for the implied decimal. The division corrects for the multiplier.

$$D = EU \frac{D_{max}}{(EU_H - EU_L)}$$

D = digital value
 EU = engineering units
 EU_H = engineering unit range high limit
 EU_L = engineering unit range low limit

Calculating Output Data: Engineering Units Conversion

$$D = 10EU \frac{D_{max}}{10(EU_H - EU_L)}$$

$$D = 525 \text{ 65535 } \frac{D}{10(140)}$$

The below example program shows how to write the program to perform the engineering unit conversion to output the 16-bit data format of 0–65535. This example assumes that the engineering units have been calculated or loaded, including a multiplier of 10, in BCD format and stored it in V2120 for output channel 1.

Output Engineering Unit Conversion / Output Data Calculation Example:

Data format = binary,

Channel 1 data memory location = V2020,

Channel 1 engineering units = 0.0–140.0 psi,

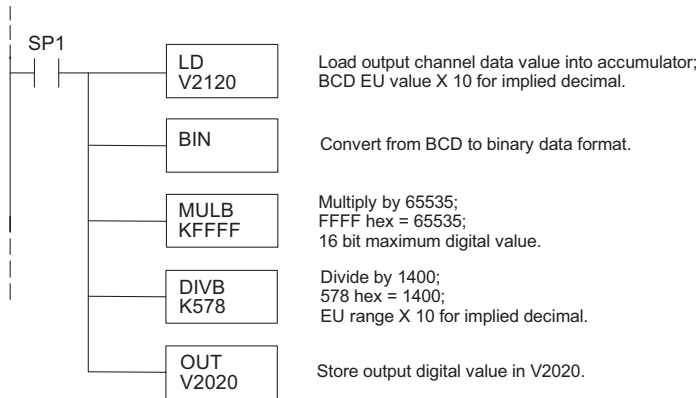

DL205 DISCRETE I/O MEMORY MAP



APPENDIX

A

In This Chapter...

Input (X) / Output (Y) Bit Map	A-2
Control Relay Bit Map	A-4
Remote I/O Bit Map (D2-260 and D2-262 only)	A-8

Appendix A: DL205 Discrete I/O Memory Map

Input (X) / Output (Y) Bit Map

This table provides a listing of the individual Input points associated with each V-memory address bit for the various CPUs. The D2-250-1 ranges apply to the D2-250.

MSB	Input (X) and Output (Y) Points for D2-230, D2-240, D2-250-1, D2-260 and D2-262 CPUs															LSB	X Input Address	Y Output Address
	15	14	13	12	11	10	9	8	7	6	5	4	3	2	1			
017	016	015	014	013	012	011	010	007	006	005	004	003	002	001	000	V40400	V40500	
037	036	035	034	033	032	031	030	027	026	025	024	023	022	021	020	V40401	V40501	
057	056	055	054	053	052	051	050	047	046	045	044	043	042	041	040	V40402	V40502	
077	076	075	074	073	072	071	070	067	066	065	064	063	062	061	060	V40403	V40503	
117	116	115	114	113	112	111	110	107	106	105	104	103	102	101	100	V40404	V40504	
137	136	135	134	133	132	131	130	127	126	125	124	123	122	121	120	V40405	V40505	
157	156	155	154	153	152	151	150	147	146	145	144	143	142	141	140	V40406	V40506	
177	176	175	174	173	172	171	170	167	166	165	164	163	162	161	160	V40407	V40507	

MSB	Input (X) and Output (Y) Points for D2-240, D2-250-1, D2-260 and D2-262 CPUs															LSB		
	217	216	215	214	213	212	211	210	207	206	205	204	203	202	201			
217	216	215	214	213	212	211	210	207	206	205	204	203	202	201	200	V40410	V40510	
237	236	235	234	233	232	231	230	227	226	225	224	223	222	221	220	V40411	V40511	
257	256	255	254	253	252	251	250	247	246	245	244	243	242	241	240	V40412	V40512	
277	276	275	274	273	272	271	270	267	266	265	264	263	262	261	260	V40413	V40513	
317	316	315	314	313	312	311	310	307	306	305	304	303	302	301	300	V40414	V40514	
337	336	335	334	333	332	331	330	327	326	325	324	323	322	321	320	V40415	V40515	
357	356	355	354	353	352	351	350	347	346	345	344	343	342	341	340	V40416	V40516	
377	376	375	374	373	372	371	370	367	366	365	364	363	362	361	360	V40417	V40517	
417	416	415	414	413	412	411	410	407	406	405	404	403	402	401	400	V40420	V40520	
437	436	435	434	433	432	431	430	427	426	425	424	423	422	421	420	V40421	V40521	
457	456	455	454	453	452	451	450	447	446	445	444	443	442	441	440	V40422	V40522	
477	476	475	474	473	472	471	470	467	466	465	464	463	462	461	460	V40423	V40523	

MSB	Additional Input (X) and Output (Y) Points for D2-250-1, D2-260, D2-262 CPUs															LSB		
	517	516	515	514	513	512	511	510	507	506	505	504	503	502	501			
517	516	515	514	513	512	511	510	507	506	505	504	503	502	501	500	V40424	V40524	
537	536	535	534	533	532	531	530	527	526	525	524	523	522	521	520	V40425	V40525	
557	556	555	554	553	552	551	550	547	546	545	544	543	542	541	540	V40426	V40526	
577	576	575	574	573	572	571	570	567	566	565	564	563	562	561	560	V40427	V40527	
617	616	615	614	613	612	611	610	607	606	605	604	603	602	601	600	V40430	V40530	
637	636	635	634	633	632	631	630	627	626	625	624	623	622	621	620	V40431	V40531	
657	656	655	654	653	652	651	650	647	646	645	644	643	642	641	640	V40432	V40532	
677	676	675	674	673	672	671	670	667	666	665	664	663	662	661	660	V40433	V40533	
717	716	715	714	713	712	711	710	707	706	705	704	703	702	701	700	V40434	V40534	
737	736	735	734	733	732	731	730	727	726	725	724	723	722	721	720	V40435	V40535	
757	756	755	754	753	752	751	750	747	746	745	744	743	742	741	740	V40436	V40536	
777	776	775	774	773	772	771	770	767	766	765	764	763	762	761	760	V40437	V40537	

Input (X) / Output (Y) Bit Map, Continued

MSB	Additional Input (X) and Output (Y) Points for D2-260 and D2-262 CPUs															LSB	X Input Address	Y Output Address
	15	14	13	12	11	10	9	8	7	6	5	4	3	2	1			
1017	1016	1015	1014	1013	1012	1011	1010	1007	1006	1005	1004	1003	1002	1001	1000	V40440	V40540	
1037	1036	1035	1034	1033	1032	1031	1030	1027	1026	1025	1024	1023	1022	1021	1020	V40441	V40541	
1057	1056	1055	1054	1053	1052	1051	1050	1047	1046	1045	1044	1043	1042	1041	1040	V40442	V40542	
1077	1076	1075	1074	1073	1072	1071	1070	1067	1066	1065	1064	1063	1062	1061	1060	V40443	V40543	
1117	1116	1115	1114	1113	1112	1111	1110	1107	1106	1105	1104	1103	1102	1101	1100	V40444	V40544	
1137	1136	1135	1134	1133	1132	1131	1130	1127	1126	1125	1124	1123	1122	1121	1120	V40445	V40545	
1157	1156	1155	1154	1153	1152	1151	1150	1147	1146	1145	1144	1143	1142	1141	1140	V40446	V40546	
1177	1176	1175	1174	1173	1172	1171	1170	1167	1166	1165	1164	1163	1162	1161	1160	V40447	V40547	
1217	1216	1215	1214	1213	1212	1211	1210	1207	1206	1205	1204	1203	1202	1201	1200	V40450	V40550	
1237	1236	1235	1234	1233	1232	1231	1230	1227	1226	1225	1224	1223	1222	1221	1220	V40451	V40551	
1257	1256	1255	1254	1253	1252	1251	1250	1247	1246	1245	1244	1243	1242	1241	1240	V40452	V40552	
1277	1276	1275	1274	1273	1272	1271	1270	1267	1266	1265	1264	1263	1262	1261	1260	V40453	V40553	
1317	1316	1315	1314	1313	1312	1311	1310	1307	1306	1305	1304	1303	1302	1301	1300	V40454	V40554	
1337	1336	1335	1334	1333	1332	1331	1330	1327	1326	1325	1324	1323	1322	1321	1320	V40455	V40555	
1357	1356	1355	1354	1353	1352	1351	1350	1347	1346	1345	1344	1343	1342	1341	1340	V40456	V40556	
1377	1376	1375	1374	1373	1372	1371	1370	1367	1366	1365	1364	1363	1362	1361	1360	V40457	V40557	
1417	1416	1415	1414	1413	1412	1411	1410	1407	1406	1405	1404	1403	1402	1401	1400	V40460	V40560	
1437	1436	1435	1434	1433	1432	1431	1430	1427	1426	1425	1424	1423	1422	1421	1420	V40461	V40561	
1457	1456	1455	1454	1453	1452	1451	1450	1447	1446	1445	1444	1443	1442	1441	1440	V40462	V40562	
1477	1476	1475	1474	1473	1472	1471	1470	1467	1466	1465	1464	1463	1462	1461	1460	V40463	V40563	
1517	1516	1515	1514	1513	1512	1511	1510	1507	1506	1505	1504	1503	1502	1501	1500	V40464	V40564	
1537	1536	1535	1534	1533	1532	1531	1530	1527	1526	1525	1524	1523	1522	1521	1520	V40465	V40565	
1557	1556	1555	1554	1553	1552	1551	1550	1547	1546	1545	1544	1543	1542	1541	1540	V40466	V40566	
1577	1576	1575	1574	1573	1572	1571	1570	1567	1566	1565	1564	1563	1562	1561	1560	V40467	V40567	
1617	1616	1615	1614	1613	1612	1611	1610	1607	1606	1605	1604	1603	1602	1601	1600	V40470	V40570	
1637	1636	1635	1634	1633	1632	1631	1630	1627	1626	1625	1624	1623	1622	1621	1620	V40471	V40571	
1657	1656	1655	1654	1653	1652	1651	1650	1647	1646	1645	1644	1643	1642	1641	1640	V40472	V40572	
1677	1676	1675	1674	1673	1672	1671	1670	1667	1666	1665	1664	1663	1662	1661	1660	V40473	V40573	
1717	1716	1715	1714	1713	1712	1711	1710	1707	1706	1705	1704	1703	1702	1701	1700	V40474	V40574	
1737	1736	1735	1734	1733	1732	1731	1730	1727	1726	1725	1724	1723	1722	1721	1720	V40475	V40575	
1757	1756	1755	1754	1753	1752	1751	1750	1747	1746	1745	1744	1743	1742	1741	1740	V40476	V40576	
1777	1776	1775	1774	1773	1772	1771	1770	1767	1766	1765	1764	1763	1762	1761	1760	V40477	V40577	

Control Relay Bit Map

This table provides a listing of the individual control relays associated with each V-memory address bit.

MSB		Control Relays (C) for D2-230, D2-240, D2-250-1, D2-260 and D2-262														LSB	Address
15	14	13	12	11	10	9	8	7	6	5	4	3	2	1	0		
017	016	015	014	013	012	011	010	007	006	005	004	003	002	001	000	V40600	
037	036	035	034	033	032	031	030	027	026	025	024	023	022	021	020	V40601	
057	056	055	054	053	052	051	050	047	046	045	044	043	042	041	040	V40602	
077	076	075	074	073	072	071	070	067	066	065	064	063	062	061	060	V40603	
117	116	115	114	113	112	111	110	107	106	105	104	103	102	101	100	V40604	
137	136	135	134	133	132	131	130	127	126	125	124	123	122	121	120	V40605	
157	156	155	154	153	152	151	150	147	146	145	144	143	142	141	140	V40606	
177	176	175	174	173	172	171	170	167	166	165	164	163	162	161	160	V40607	
217	216	215	214	213	212	211	210	207	206	205	204	203	202	201	200	V40610	
237	236	235	234	233	232	231	230	227	226	225	224	223	222	221	220	V40611	
257	256	255	254	253	252	251	250	247	246	245	244	243	242	241	240	V40612	
277	276	275	274	273	272	271	270	267	266	265	264	263	262	261	260	V40613	
317	316	315	314	313	312	311	310	307	306	305	304	303	302	301	300	V40614	
337	336	335	334	333	332	331	330	327	326	325	324	323	322	321	320	V40615	
357	356	355	354	353	352	351	350	347	346	345	344	343	342	341	340	V40616	
377	376	375	374	373	372	371	370	367	366	365	364	363	362	361	360	V40617	

MSB		Additional Control Relays (C) for D2-250-1, D2-260 and D2-262														LSB	Address
417	416	415	414	413	412	411	410	407	406	405	404	403	402	401	400	V40620	
437	436	435	434	433	432	431	430	427	426	425	424	423	422	421	420	V40621	
457	456	455	454	453	452	451	450	447	446	445	444	443	442	441	440	V40622	
477	476	475	474	473	472	471	470	467	466	465	464	463	462	461	460	V40623	
517	516	515	514	513	512	511	510	507	506	505	504	503	502	501	500	V40624	
537	536	535	534	533	532	531	530	527	526	525	524	523	522	521	520	V40625	
557	556	555	554	553	552	551	550	547	546	545	544	543	542	541	540	V40626	
577	576	575	574	573	572	571	570	567	566	565	564	563	562	561	560	V40627	
617	616	615	614	613	612	611	610	607	606	605	604	603	602	601	600	V40630	
637	636	635	634	633	632	631	630	627	626	625	624	623	622	621	620	V40631	
657	656	655	654	653	652	651	650	647	646	645	644	643	642	641	640	V40632	
677	676	675	674	673	672	671	670	667	666	665	664	663	662	661	660	V40633	
717	716	715	714	713	712	711	710	707	706	705	704	703	702	701	700	V40634	
737	736	735	734	733	732	731	730	727	726	725	724	723	722	721	720	V40635	
757	756	755	754	753	752	751	750	747	746	745	744	743	742	741	740	V40636	
777	776	775	774	773	772	771	770	767	766	765	764	763	762	761	760	V40637	

Control Relay Bit Map, Continued

MSB		Additional Control Relays (C) for D2-250-1, D2-260 and D2-262													LSB		Address
15	14	13	12	11	10	9	8	7	6	5	4	3	2	1	0		
1017	1016	1015	1014	1013	1012	1011	1010	1007	1006	1005	1004	1003	1002	1001	1000	V40640	
1037	1036	1035	1034	1033	1032	1031	1030	1027	1026	1025	1024	1023	1022	1021	1020	V40641	
1057	1056	1055	1054	1053	1052	1051	1050	1047	1046	1045	1044	1043	1042	1041	1040	V40642	
1077	1076	1075	1074	1073	1072	1071	1070	1067	1066	1065	1064	1063	1062	1061	1060	V40643	
1117	1116	1115	1114	1113	1112	1111	1110	1107	1106	1105	1104	1103	1102	1101	1100	V40644	
1137	1136	1135	1134	1133	1132	1131	1130	1127	1126	1125	1124	1123	1122	1121	1120	V40645	
1157	1156	1155	1154	1153	1152	1151	1150	1147	1146	1145	1144	1143	1142	1141	1140	V40646	
1177	1176	1175	1174	1173	1172	1171	1170	1167	1166	1165	1164	1163	1162	1161	1160	V40647	
1217	1216	1215	1214	1213	1212	1211	1210	1207	1206	1205	1204	1203	1202	1201	1200	V40650	
1237	1236	1235	1234	1233	1232	1231	1230	1227	1226	1225	1224	1223	1222	1221	1220	V40651	
1257	1256	1255	1254	1253	1252	1251	1250	1247	1246	1245	1244	1243	1242	1241	1240	V40652	
1277	1276	1275	1274	1273	1272	1271	1270	1267	1266	1265	1264	1263	1262	1261	1260	V40653	
1317	1316	1315	1314	1313	1312	1311	1310	1307	1306	1305	1304	1303	1302	1301	1300	V40654	
1337	1336	1335	1334	1333	1332	1331	1330	1327	1326	1325	1324	1323	1322	1321	1320	V40655	
1357	1356	1355	1354	1353	1352	1351	1350	1347	1346	1345	1344	1343	1342	1341	1340	V40656	
1377	1376	1375	1374	1373	1372	1371	1370	1367	1366	1365	1364	1363	1362	1361	1360	V40657	
1417	1416	1415	1414	1413	1412	1411	1410	1407	1406	1405	1404	1403	1402	1401	1400	V40660	
1437	1436	1435	1434	1433	1432	1431	1430	1427	1426	1425	1424	1423	1422	1421	1420	V40661	
1457	1456	1455	1454	1453	1452	1451	1450	1447	1446	1445	1444	1443	1442	1441	1440	V40662	
1477	1476	1475	1474	1473	1472	1471	1470	1467	1466	1465	1464	1463	1462	1461	1460	V40663	
1517	1516	1515	1514	1513	1512	1511	1510	1507	1506	1505	1504	1503	1502	1501	1500	V40664	
1537	1536	1535	1534	1533	1532	1531	1530	1527	1526	1525	1524	1523	1522	1521	1520	V40665	
1557	1556	1555	1554	1553	1552	1551	1550	1547	1546	1545	1544	1543	1542	1541	1540	V40666	
1577	1576	1575	1574	1573	1572	1571	1570	1567	1566	1565	1564	1563	1562	1561	1560	V40667	
1617	1616	1615	1614	1613	1612	1611	1610	1607	1606	1605	1604	1603	1602	1601	1600	V40670	
1637	1636	1635	1634	1633	1632	1631	1630	1627	1626	1625	1624	1623	1622	1621	1620	V40671	
1657	1656	1655	1654	1653	1652	1651	1650	1647	1646	1645	1644	1643	1642	1641	1640	V40672	
1677	1676	1675	1674	1673	1672	1671	1670	1667	1666	1665	1664	1663	1662	1661	1660	V40673	
1717	1716	1715	1714	1713	1712	1711	1710	1707	1706	1705	1704	1703	1702	1701	1700	V40674	
1737	1736	1735	1734	1733	1732	1731	1730	1727	1726	1725	1724	1723	1722	1721	1720	V40675	
1757	1756	1755	1754	1753	1752	1751	1750	1747	1746	1745	1744	1743	1742	1741	1740	V40676	
1777	1776	1775	1774	1773	1772	1771	1770	1767	1766	1765	1764	1763	1762	1761	1760	V40677	

Control Relay Bit Map, Continued

This portion of the table shows additional Control Relays points available with the D2-260 and D2-262.

MSB		Additional Control Relays (C) for D2-260 and D2-262 CPUs														LSB		Address
15	14	13	12	11	10	9	8	7	6	5	4	3	2	1	0			
2017	2016	2015	2014	2013	2012	2011	2010	2007	2006	2005	2004	2003	2002	2001	2000	V40700		
2037	2036	2035	2034	2033	2032	2031	2030	2027	2026	2025	2024	2023	2022	2021	2020	V40701		
2057	2056	2055	2054	2053	2052	2051	2050	2047	2046	2045	2044	2043	2042	2041	2040	V40702		
2077	2076	2075	2074	2073	2072	2071	2070	2067	2066	2065	2064	2063	2062	2061	2060	V40703		
2117	2116	2115	2114	2113	2112	2111	2110	2107	2106	2105	2104	2103	2102	2101	2100	V40704		
2137	2136	2135	2134	2133	2132	2131	2130	2127	2126	2125	2124	2123	2122	2121	2120	V40705		
2157	2156	2155	2154	2153	2152	2151	2150	2147	2146	2145	2144	2143	2142	2141	2140	V40706		
2177	2176	2175	2174	2173	2172	2171	2170	2167	2166	2165	2164	2163	2162	2161	2160	V40707		
2217	2216	2215	2214	2213	2212	2211	2210	2207	2206	2205	2204	2203	2202	2201	2200	V40710		
2237	2236	2235	2234	2233	2232	2231	2230	2227	2226	2225	2224	2223	2222	2221	2220	V40711		
2257	2256	2255	2254	2253	2252	2251	2250	2247	2246	2245	2244	2243	2242	2241	2240	V40712		
2277	2276	2275	2274	2273	2272	2271	2270	2267	2266	2265	2264	2263	2262	2261	2260	V40713		
2317	2316	2315	2314	2313	2312	2311	2310	2307	2306	2305	2304	2303	2302	2301	2300	V40714		
2337	2336	2335	2334	2333	2332	2331	2330	2327	2326	2325	2324	2323	2322	2321	2320	V40715		
2357	2356	2355	2354	2353	2352	2351	2350	2347	2346	2345	2344	2343	2342	2341	2340	V40716		
2377	2376	2375	2374	2373	2372	2371	2370	2367	2366	2365	2364	2363	2362	2361	2360	V40717		
2417	2416	2415	2414	2413	2412	2411	2410	2407	2406	2405	2404	2403	2402	2401	2400	V40720		
2437	2436	2435	2434	2433	2432	2431	2430	2427	2426	2425	2424	2423	2422	2421	2420	V40721		
2457	2456	2455	2454	2453	2452	2451	2450	2447	2446	2445	2444	2443	2442	2441	2440	V40722		
2477	2476	2475	2474	2473	2472	2471	2470	2467	2466	2465	2464	2463	2462	2461	2460	V40723		
2517	2516	2515	2514	2513	2512	2511	2510	2507	2506	2505	2504	2503	2502	2501	2500	V40724		
2537	2536	2535	2534	2533	2532	2531	2530	2527	2526	2525	2524	2523	2522	2521	2520	V40725		
2557	2556	2555	2554	2553	2552	2551	2550	2547	2546	2545	2544	2543	2542	2541	2540	V40726		
2577	2576	2575	2574	2573	2572	2571	2570	2567	2566	2565	2564	2563	2562	2561	2560	V40727		
2617	2616	2615	2614	2613	2612	2611	2610	2607	2606	2605	2604	2603	2602	2601	2600	V40730		
2637	2636	2635	2634	2633	2632	2631	2630	2627	2626	2625	2624	2623	2622	2621	2620	V40731		
2657	2656	2655	2654	2653	2652	2651	2650	2647	2646	2645	2644	2643	2642	2641	2640	V40732		
2677	2676	2675	2674	2673	2672	2671	2670	2667	2666	2665	2664	2663	2662	2661	2660	V40733		
2717	2716	2715	2714	2713	2712	2711	2710	2707	2706	2705	2704	2703	2702	2701	2700	V40734		
2737	2736	2735	2734	2733	2732	2731	2730	2727	2726	2725	2724	2723	2722	2721	2720	V40735		
2757	2756	2755	2754	2753	2752	2751	2750	2747	2746	2745	2744	2743	2742	2741	2740	V40736		
2777	2776	2775	2774	2773	2772	2771	2770	2767	2766	2765	2764	2763	2762	2761	2760	V40737		

Control Relay Bit Map, Continued

MSB	Additional Control Relays (C) for D2-260 and D2-262 CPUs														LSB	Address
	15	14	13	12	11	10	9	8	7	6	5	4	3	2		
3017	3016	3015	3014	3013	3012	3011	3010	3007	3006	3005	3004	3003	3002	3001	3000	V40740
3037	3036	3035	3034	3033	3032	3031	3030	3027	3026	3025	3024	3023	3022	3021	3020	V40741
3057	3056	3055	3054	3053	3052	3051	3050	3047	3046	3045	3044	3043	3042	3041	3040	V40742
3077	3076	3075	3074	3073	3072	3071	3070	3067	3066	3065	3064	3063	3062	3061	3060	V40743
3117	3116	3115	3114	3113	3112	3111	3110	3107	3106	3105	3104	3103	3102	3101	3100	V40744
3137	3136	3135	3134	3133	3132	3131	3130	3127	3126	3125	3124	3123	3122	3121	3120	V40745
3157	3156	3155	3154	3153	3152	3151	3150	3147	3146	3145	3144	3143	3142	3141	3140	V40746
3177	3176	3175	3174	3173	3172	3171	3170	3167	3166	3165	3164	3163	3162	3161	3160	V40747
3217	3216	3215	3214	3213	3212	3211	3210	3207	3206	3205	3204	3203	3202	3201	3200	V40750
3237	3236	3235	3234	3233	3232	3231	3230	3227	3226	3225	3224	3223	3222	3221	3220	V40751
3257	3256	3255	3254	3253	3252	3251	3250	3247	3246	3245	3244	3243	3242	3241	3240	V40752
3277	3276	3275	3274	3273	3272	3271	3270	3267	3266	3265	3264	3263	3262	3261	3260	V40753
3317	3316	3315	3314	3313	3312	3311	3310	3307	3306	3305	3304	3303	3302	3301	3300	V40754
3337	3336	3335	3334	3333	3332	3331	3330	3327	3326	3325	3324	3323	3322	3321	3320	V40755
3357	3356	3355	3354	3353	3352	3351	3350	3347	3346	3345	3344	3343	3342	3341	3340	V40756
3377	3376	3375	3374	3373	3372	3371	3370	3367	3366	3365	3364	3363	3362	3361	3360	V40757
3417	3416	3415	3414	3413	3412	3411	3410	3407	3406	3405	3404	3403	3402	3401	3400	V40760
3437	3436	3435	3434	3433	3432	3431	3430	3427	3426	3425	3424	3423	3422	3421	3420	V40761
3457	3456	3455	3454	3453	3452	3451	3450	3447	3446	3445	3444	3443	3442	3441	3440	V40762
3477	3476	3475	3474	3473	3472	3471	3470	3467	3466	3465	3464	3463	3462	3461	3460	V40763
3517	3516	3515	3514	3513	3512	3511	3510	3507	3506	3505	3504	3503	3502	3501	3500	V40764
3537	3536	3535	3534	3533	3532	3531	3530	3527	3526	3525	3524	3523	3522	3521	3520	V40765
3557	3556	3555	3554	3553	3552	3551	3550	3547	3546	3545	3544	3543	3542	3541	3540	V40766
3577	3576	3575	3574	3573	3572	3571	3570	3567	3566	3565	3564	3563	3562	3561	3560	V40767
3617	3616	3615	3614	3613	3612	3611	3610	3607	3606	3605	3604	3603	3602	3601	3600	V40770
3637	3636	3635	3634	3633	3632	3631	3630	3627	3626	3625	3624	3623	3622	3621	3620	V40771
3657	3656	3655	3654	3653	3652	3651	3650	3647	3646	3645	3644	3643	3642	3641	3640	V40772
3677	3676	3675	3674	3673	3672	3671	3670	3667	3666	3665	3664	3663	3662	3661	3660	V40773
3717	3716	3715	3714	3713	3712	3711	3710	3707	3706	3705	3704	3703	3702	3701	3700	V40774
3737	3736	3735	3734	3733	3732	3731	3730	3727	3726	3725	3724	3723	3722	3721	3720	V40775
3757	3756	3755	3754	3753	3752	3751	3750	3747	3746	3745	3744	3743	3742	3741	3740	V40776
3777	3776	3775	3774	3773	3772	3771	3770	3767	3766	3765	3764	3763	3762	3761	3760	V40777

Remote I/O Bit Map (D2-260 and D2-262 only)

This table provides a listing of the individual remote I/O points associated with each V-memory address bit.

MSB		Remote I/O (GX) and (GY) Points for D2-260 and D2-262 CPUs														LSB	GX Address	GY Address
15	14	13	12	11	10	9	8	7	6	5	4	3	2	1	0			
017	016	015	014	013	012	011	010	007	006	005	004	003	002	001	000	V40000	V40200	
037	036	035	034	033	032	031	030	027	026	025	024	023	022	021	020	V40001	V40201	
057	056	055	054	053	052	051	050	047	046	045	044	043	042	041	040	V40002	V40202	
077	076	075	074	073	072	071	070	067	066	065	064	063	062	061	060	V40003	V40203	
117	116	115	114	113	112	111	110	107	106	105	104	103	102	101	100	V40004	V40204	
137	136	135	134	133	132	131	130	127	126	125	124	123	122	121	120	V40005	V40205	
157	156	155	154	153	152	151	150	147	146	145	144	143	142	141	140	V40006	V40206	
177	176	175	174	173	172	171	170	167	166	165	164	163	162	161	160	V40007	V40207	
217	216	215	214	213	212	211	210	207	206	205	204	203	202	201	200	V40010	V40210	
237	236	235	234	233	232	231	230	227	226	225	224	223	222	221	220	V40011	V40211	
257	256	255	254	253	252	251	250	247	246	245	244	243	242	241	240	V40012	V40212	
277	276	275	274	273	272	271	270	267	266	265	264	263	262	261	260	V40013	V40213	
317	316	315	314	313	312	311	310	307	306	305	304	303	302	301	300	V40014	V40214	
337	336	335	334	333	332	331	330	327	326	325	324	323	322	321	320	V40015	V40215	
357	356	355	354	353	352	351	350	347	346	345	344	343	342	341	340	V40016	V40216	
377	376	375	374	373	372	371	370	367	366	365	364	363	362	361	360	V40017	V40217	
417	416	415	414	413	412	411	410	407	406	405	404	403	402	401	400	V40020	V40220	
437	436	435	434	433	432	431	430	427	426	425	424	423	422	421	420	V40021	V40221	
457	456	455	454	453	452	451	450	447	446	445	444	443	442	441	440	V40022	V40222	
477	476	475	474	473	472	471	470	467	466	465	464	463	462	461	460	V40023	V40223	
517	516	515	514	513	512	511	510	507	506	505	504	503	502	501	500	V40024	V40224	
537	536	535	534	533	532	531	530	527	526	525	524	523	522	521	520	V40025	V40225	
557	556	555	554	553	552	551	550	547	546	545	544	543	542	541	540	V40026	V40226	
577	576	575	574	573	572	571	570	567	566	565	564	563	562	561	560	V40027	V40227	
617	616	615	614	613	612	611	610	607	606	605	604	603	602	601	600	V40030	V40230	
637	636	635	634	633	632	631	630	627	626	625	624	623	622	621	620	V40031	V40231	
657	656	655	654	653	652	651	650	647	646	645	644	643	642	641	640	V40032	V40232	
677	676	675	674	673	672	671	670	667	666	665	664	663	662	661	660	V40033	V40233	
717	716	715	714	713	712	711	710	707	706	705	704	703	702	701	700	V40034	V40234	
737	736	735	734	733	732	731	730	727	726	725	724	723	722	721	720	V40035	V40235	
757	756	755	754	753	752	751	750	747	746	745	744	743	742	741	740	V40036	V40236	
777	776	775	774	773	772	771	770	767	766	765	764	763	762	761	760	V40037	V40237	

Remote I/O Bit Map (D2-260 and D2-262 only), Continued

MSB	Additional Remote I/O (GX) and (GY) Points for D2-260 and D2-262 CPUs														LSB	GX Address	GY Address
15	14	13	12	11	10	9	8	7	6	5	4	3	2	1	0		
1017	1016	1015	1014	1013	1012	1011	1010	1007	1006	1005	1004	1003	1002	1001	1000	V40040	V40240
1037	1036	1035	1034	1033	1032	1031	1030	1027	1026	1025	1024	1023	1022	1021	1020	V40041	V40241
1057	1056	1055	1054	1053	1052	1051	1050	1047	1046	1045	1044	1043	1042	1041	1040	V40042	V40242
1077	1076	1075	1074	1073	1072	1071	1070	1067	1066	1065	1064	1063	1062	1061	1060	V40043	V40243
1117	1116	1115	1114	1113	1112	1111	1110	1107	1106	1105	1104	1103	1102	1101	1100	V40044	V40244
1137	1136	1135	1134	1133	1132	1131	1130	1127	1126	1125	1124	1123	1122	1121	1120	V40045	V40245
1157	1156	1155	1154	1153	1152	1151	1150	1147	1146	1145	1144	1143	1142	1141	1140	V40046	V40246
1177	1176	1175	1174	1173	1172	1171	1170	1167	1166	1165	1164	1163	1162	1161	1160	V40047	V40247
1217	1216	1215	1214	1213	1212	1211	1210	1207	1206	1205	1204	1203	1202	1201	1200	V40050	V40250
1237	1236	1235	1234	1233	1232	1231	1230	1227	1226	1225	1224	1223	1222	1221	1220	V40051	V40251
1257	1256	1255	1254	1253	1252	1251	1250	1247	1246	1245	1244	1243	1242	1241	1240	V40052	V40252
1277	1276	1275	1274	1273	1272	1271	1270	1267	1266	1265	1264	1263	1262	1261	1260	V40053	V40253
1317	1316	1315	1314	1313	1312	1311	1310	1307	1306	1305	1304	1303	1302	1301	1300	V40054	V40254
1337	1336	1335	1334	1333	1332	1331	1330	1327	1326	1325	1324	1323	1322	1321	1320	V40055	V40255
1357	1356	1355	1354	1353	1352	1351	1350	1347	1346	1345	1344	1343	1342	1341	1340	V40056	V40256
1377	1376	1375	1374	1373	1372	1371	1370	1367	1366	1365	1364	1363	1362	1361	1360	V40057	V40257
1417	1416	1415	1414	1413	1412	1411	1410	1407	1406	1405	1404	1403	1402	1401	1400	V40060	V40260
1437	1436	1435	1434	1433	1432	1431	1430	1427	1426	1425	1424	1423	1422	1421	1420	V40061	V40261
1457	1456	1455	1454	1453	1452	1451	1450	1447	1446	1445	1444	1443	1442	1441	1440	V40062	V40262
1477	1476	1475	1474	1473	1472	1471	1470	1467	1466	1465	1464	1463	1462	1461	1460	V40063	V40263
1517	1516	1515	1514	1513	1512	1511	1510	1507	1506	1505	1504	1503	1502	1501	1500	V40064	V40264
1537	1536	1535	1534	1533	1532	1531	1530	1527	1526	1525	1524	1523	1522	1521	1520	V40065	V40265
1557	1556	1555	1554	1553	1552	1551	1550	1547	1546	1545	1544	1543	1542	1541	1540	V40066	V40266
1577	1576	1575	1574	1573	1572	1571	1570	1567	1566	1565	1564	1563	1562	1561	1560	V40067	V40267
1617	1616	1615	1614	1613	1612	1611	1610	1607	1606	1605	1604	1603	1602	1601	1600	V40070	V40270
1637	1636	1635	1634	1633	1632	1631	1630	1627	1626	1625	1624	1623	1622	1621	1620	V40071	V40271
1657	1656	1655	1654	1653	1652	1651	1650	1647	1646	1645	1644	1643	1642	1641	1640	V40072	V40272
1677	1676	1675	1674	1673	1672	1671	1670	1667	1666	1665	1664	1663	1662	1661	1660	V40073	V40273
1717	1716	1715	1714	1713	1712	1711	1710	1707	1706	1705	1704	1703	1702	1701	1700	V40074	V40274
1737	1736	1735	1734	1733	1732	1731	1730	1727	1726	1725	1724	1723	1722	1721	1720	V40075	V40275
1757	1756	1755	1754	1753	1752	1751	1750	1747	1746	1745	1744	1743	1742	1741	1740	V40076	V40276
1777	1776	1775	1774	1773	1772	1771	1770	1767	1766	1765	1764	1763	1762	1761	1760	V40077	V40277

Remote I/O Bit Map (D2-260 and D2-262 only), Continued

<i>M5B</i>															<i>Additional Remote I/O (GX) and (GY) Points for D2-260 and D2-262 CPUs</i>		<i>LSB</i>	<i>GX</i>	<i>GY</i>
15	14	13	12	11	10	9	8	7	6	5	4	3	2	1	0	Address	Address		
2017	2016	2015	2014	2013	2012	2011	2010	2007	2006	2005	2004	2003	2002	2001	2000	V40100	V40300		
2037	2036	2035	2034	2033	2032	2031	2030	2027	2026	2025	2024	2023	2022	2021	2020	V40101	V40301		
2057	2056	2055	2054	2053	2052	2051	2050	2047	2046	2045	2044	2043	2042	2041	2040	V40102	V40302		
2077	2076	2075	2074	2073	2072	2071	2070	2067	2066	2065	2064	2063	2062	2061	2060	V40103	V40303		
2117	2116	2115	2114	2113	2112	2111	2110	2107	2106	2105	2104	2103	2102	2101	2100	V40104	V40304		
2137	2136	2135	2134	2133	2132	2131	2130	2127	2126	2125	2124	2123	2122	2121	2120	V40105	V40305		
2157	2156	2155	2154	2153	2152	2151	2150	2147	2146	2145	2144	2143	2142	2141	2140	V40106	V40306		
2177	2176	2175	2174	2173	2172	2171	2170	2167	2166	2165	2164	2163	2162	2161	2160	V40107	V40307		
2217	2216	2215	2214	2213	2212	2211	2210	2207	2206	2205	2204	2203	2202	2201	2200	V40110	V40310		
2237	2236	2235	2234	2233	2232	2231	2230	2227	2226	2225	2224	2223	2222	2221	2220	V40111	V40311		
2257	2256	2255	2254	2253	2252	2251	2250	2247	2246	2245	2244	2243	2242	2241	2240	V40112	V40312		
2277	2276	2275	2274	2273	2272	2271	2270	2267	2266	2265	2264	2263	2262	2261	2260	V40113	V40313		
2317	2316	2315	2314	2313	2312	2311	2310	2307	2306	2305	2304	2303	2302	2301	2300	V40114	V40314		
2337	2336	2335	2334	2333	2332	2331	2330	2327	2326	2325	2324	2323	2322	2321	2320	V40115	V40315		
2357	2356	2355	2354	2353	2352	2351	2350	2347	2346	2345	2344	2343	2342	2341	2340	V40116	V40316		
2377	2376	2375	2374	2373	2372	2371	2370	2367	2366	2365	2364	2363	2362	2361	2360	V40117	V40317		
2417	2416	2415	2414	2413	2412	2411	2410	2407	2406	2405	2404	2403	2402	2401	2400	V40120	V40320		
2437	2436	2435	2434	2433	2432	2431	2430	2427	2426	2425	2424	2423	2422	2421	2420	V40121	V40321		
2457	2456	2455	2454	2453	2452	2451	2450	2447	2446	2445	2444	2443	2442	2441	2440	V40122	V40322		
2477	2476	2475	2474	2473	2472	2471	2470	2467	2466	2465	2464	2463	2462	2461	2460	V40123	V40323		
2517	2516	2515	2514	2513	2512	2511	2510	2507	2506	2505	2504	2503	2502	2501	2500	V40124	V40324		
2537	2536	2535	2534	2533	2532	2531	2530	2527	2526	2525	2524	2523	2522	2521	2520	V40125	V40325		
2557	2556	2555	2554	2553	2552	2551	2550	2547	2546	2545	2544	2543	2542	2541	2540	V40126	V40326		
2577	2576	2575	2574	2573	2572	2571	2570	2567	2566	2565	2564	2563	2562	2561	2560	V40127	V40327		
2617	2616	2615	2614	2613	2612	2611	2610	2607	2606	2605	2604	2603	2602	2601	2600	V40130	V40330		
2637	2636	2635	2634	2633	2632	2631	2630	2627	2626	2625	2624	2623	2622	2621	2620	V40131	V40331		
2657	2656	2655	2654	2653	2652	2651	2650	2647	2646	2645	2644	2643	2642	2641	2640	V40132	V40332		
2677	2676	2675	2674	2673	2672	2671	2670	2667	2666	2665	2664	2663	2662	2661	2660	V40133	V40333		
2717	2716	2715	2714	2713	2712	2711	2710	2707	2706	2705	2704	2703	2702	2701	2700	V40134	V40334		
2737	2736	2735	2734	2733	2732	2731	2730	2727	2726	2725	2724	2723	2722	2721	2720	V40135	V40335		
2757	2756	2755	2754	2753	2752	2751	2750	2747	2746	2745	2744	2743	2742	2741	2740	V40136	V40336		
2777	2776	2775	2774	2773	2772	2771	2770	2767	2766	2765	2764	2763	2762	2761	2760	V40137	V40337		

Remote I/O Bit Map (D2-260 and D2-262 only), Continued

MSB															Additional Remote I/O (GX) and (GY) Points for D2-260 and D2-262 CPUs		LSB	GX	GY
15	14	13	12	11	10	9	8	7	6	5	4	3	2	1	0	Address	Address		
3017	3016	3015	3014	3013	3012	3011	3010	3007	3006	3005	3004	3003	3002	3001	3000	V40140	V40340		
3037	3036	3035	3034	3033	3032	3031	3030	3027	3026	3025	3024	3023	3022	3021	3020	V40141	V40341		
3057	3056	3055	3054	3053	3052	3051	3050	3047	3046	3045	3044	3043	3042	3041	3040	V40142	V40342		
3077	3076	3075	3074	3073	3072	3071	3070	3067	3066	3065	3064	3063	3062	3061	3060	V40143	V40343		
3117	3116	3115	3114	3113	3112	3111	3110	3107	3106	3105	3104	3103	3102	3101	3100	V40144	V40344		
3137	3136	3135	3134	3133	3132	3131	3130	3127	3126	3125	3124	3123	3122	3121	3120	V40145	V40345		
3157	3156	3155	3154	3153	3152	3151	3150	3147	3146	3145	3144	3143	3142	3141	3140	V40146	V40346		
3177	3176	3175	3174	3173	3172	3171	3170	3167	3166	3165	3164	3163	3162	3161	3160	V40147	V40347		
3217	3216	3215	3214	3213	3212	3211	3210	3207	3206	3205	3204	3203	3202	3201	3200	V40150	V40350		
3237	3236	3235	3234	3233	3232	3231	3230	3227	3226	3225	3224	3223	3222	3221	3220	V40151	V40351		
3257	3256	3255	3254	3253	3252	3251	3250	3247	3246	3245	3244	3243	3242	3241	3240	V40152	V40352		
3277	3276	3275	3274	3273	3272	3271	3270	3267	3266	3265	3264	3263	3262	3261	3260	V40153	V40353		
3317	3316	3315	3314	3313	3312	3311	3310	3307	3306	3305	3304	3303	3302	3301	3300	V40154	V40354		
3337	3336	3335	3334	3333	3332	3331	3330	3327	3326	3325	3324	3323	3322	3321	3320	V40155	V40355		
3357	3356	3355	3354	3353	3352	3351	3350	3347	3346	3345	3344	3343	3342	3341	3340	V40156	V40356		
3377	3376	3375	3374	3373	3372	3371	3370	3367	3366	3365	3364	3363	3362	3361	3360	V40157	V40357		
3417	3416	3415	3414	3413	3412	3411	3410	3407	3406	3405	3404	3403	3402	3401	3400	V40160	V40360		
3437	3436	3435	3434	3433	3432	3431	3430	3427	3426	3425	3424	3423	3422	3421	3420	V40161	V40361		
3457	3456	3455	3454	3453	3452	3451	3450	3447	3446	3445	3444	3443	3442	3441	3440	V40162	V40362		
3477	3476	3475	3474	3473	3472	3471	3470	3467	3466	3465	3464	3463	3462	3461	3460	V40163	V40363		
3517	3516	3515	3514	3513	3512	3511	3510	3507	3506	3505	3504	3503	3502	3501	3500	V40164	V40364		
3537	3536	3535	3534	3533	3532	3531	3530	3527	3526	3525	3524	3523	3522	3521	3520	V40165	V40365		
3557	3556	3555	3554	3553	3552	3551	3550	3547	3546	3545	3544	3543	3542	3541	3540	V40166	V40366		
3577	3576	3575	3574	3573	3572	3571	3570	3567	3566	3565	3564	3563	3562	3561	3560	V40167	V40367		
3617	3616	3615	3614	3613	3612	3611	3610	3607	3606	3605	3604	3603	3602	3601	3600	V40170	V40370		
3637	3636	3635	3634	3633	3632	3631	3630	3627	3626	3625	3624	3623	3622	3621	3620	V40171	V40371		
3657	3656	3655	3654	3653	3652	3651	3650	3647	3646	3645	3644	3643	3642	3641	3640	V40172	V40372		
3677	3676	3675	3674	3673	3672	3671	3670	3667	3666	3665	3664	3663	3662	3661	3660	V40173	V40373		
3717	3716	3715	3714	3713	3712	3711	3710	3707	3706	3705	3704	3703	3702	3701	3700	V40174	V40374		
3737	3736	3735	3734	3733	3732	3731	3730	3727	3726	3725	3724	3723	3722	3721	3720	V40175	V40375		
3757	3756	3755	3754	3753	3752	3751	3750	3747	3746	3745	3744	3743	3742	3741	3740	V40176	V40376		
3777	3776	3775	3774	3773	3772	3771	3770	3767	3766	3765	3764	3763	3762	3761	3760	V40177	V40377		