

# PLC MEMORY

---



In this Appendix...

DL05 PLC Memory.....	F-2
----------------------	-----

# DL05 PLC Memory

When designing a PLC application, it is important for the PLC user to understand the different types of memory in the PLC. The DL05 PLC uses two types of memory: RAM and EEPROM. RAM is Random Access Memory and EEPROM is Electrically Erasable Programmable Read Only Memory. The PLC program is stored in EEPROM, and the PLC V-memory data is stored in RAM. There is also a small range of V-memory that can be copied to EEPROM which will be explained later.

The V-memory in RAM can be configured as either retentive or non-retentive.

Retentive memory is memory that is configured by the user to maintain values through a power cycle or a PROGRAM to RUN transition. Non-retentive memory is memory that is configured by the PLC user to clear data after a power cycle or a PROGRAM to RUN transition. The retentive ranges can be configured with either the handheld programmer using AUX57 or *DirectSOFT* 5 (PLC Setup).

The contents of RAM memory can be written to and read from for an infinite number of times, but RAM requires a power source to maintain the contents of memory. The contents of RAM are maintained by the internal power supply (5VDC) only while the PLC is powered by an external source, normally 120VAC. When power to the PLC is turned off, the contents of RAM are maintained by a "Super-Capacitor". If the Super-Capacitor ever discharges, the contents of RAM will be lost. The data retention time of the Super-Capacitor backed RAM is 3 weeks maximum, and 4 1/2 days minimum (at 60° C).

The contents of EEPROM memory can be read an infinite number of times, but there is a limit to the number of times it can be written to (typical specification is 100,000 writes). EEPROM does not require a power source to maintain the memory contents. It will retain the contents of memory indefinitely.

PLC user V-memory is stored in both volatile RAM and non-volatile EEPROM memory. Data being stored in RAM uses V400-V677, V1200-V7377 and V10000-V17777 which is volatile. Data stored in EEPROM uses V7400-V7577 and V700-V777, V7600-V7777 and V36000-V37777 are non-volatile.

Data values that must be retained for long periods of time, when the PLC is powered off, should be stored in EEPROM based V-memory. Since EEPROM is limited to the number of times it can be written to, it is suggested that transitional logic, such as a one-shot, be used to write the data one time instead on each CPU scan.

Data values that are continually changing or which can be initialized with program logic should be stored in RAM based V-memory.

**Non-volatile V-memory in the DL05**

There are 2 types of memory assigned for the non-volatile V-memory area. They are RAM and flash ROM (EEPROM). They are sharing the same V-memory addresses; however, you can only use the MOV instruction, D2-HPP and DirectSOFT to write data to the flash ROM. When you write data to the flash ROM, the same data is also written to RAM. If you use other instructions, you can only write data to RAM. When you read data from the non-volatile V-memory area, the data is always read from RAM.

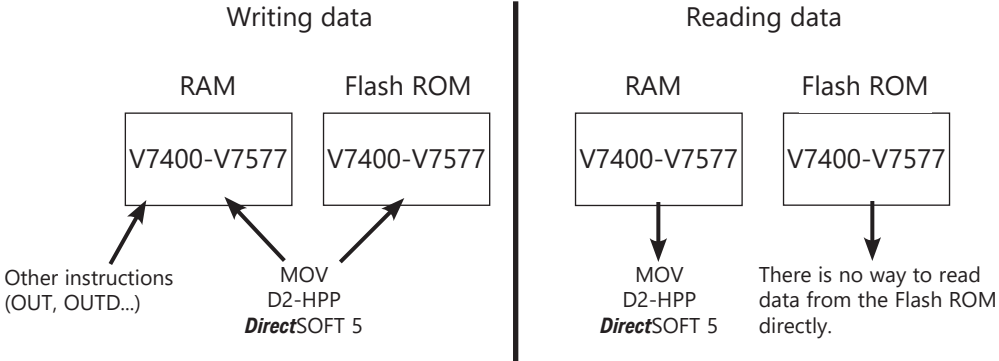

After a power cycle, the PLC always copies the data in the flash ROM to the RAM.

If you use the instructions except for the MOV instruction to write data into the non-volatile V-memory area, you only update the data in RAM. After a power cycle, the PLC copies the previous data from the flash memory to the RAM, so you may think the data you changed has disappeared. To avoid trouble such as this, we recommend that you use the MOV instruction.

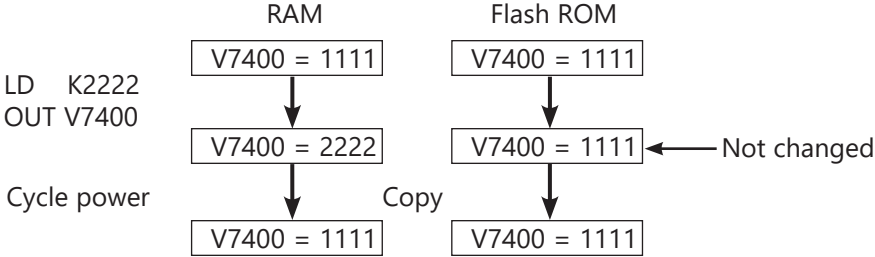

This appears to be previous data returning.