

BX 18/18E WIRING



In This Chapter...

BX 18/18E Micro PLC Units (MPUs) Overview	4-2
BX 18 MPUs General Specifications	4-3
BX 18E MPUs General Specifications	4-4
BX 18/18E MPU Wiring Termination Selection	4-5
BX 18 Micro PLC Units (MPUs)	4-9
BX-DM1-18ED1 Wiring	4-9
BX-DM1-18ED1-D Wiring	4-15
BX-DM1-18ED2 Wiring	4-21
BX-DM1-18ED2-D Wiring	4-27
BX-DM1-18ER Wiring	4-33
BX-DM1-18ER-D Wiring	4-39
BX-DM1-18AR Wiring	4-45
BX 18E Micro PLC Units (MPUs)	4-50
BX-DM1E-18ED13 Wiring	4-50
BX-DM1E-18ED13-D Wiring	4-59
BX-DM1E-18ED23 Wiring	4-68
BX-DM1E-18ED23-D Wiring	4-77
BX-DM1E-18ER3 Wiring	4-86
BX-DM1E-18ER3-D Wiring	4-95
BX-DM1E-18AR3 Wiring	4-104

BX 18/18E Micro PLC Units (MPUs) Overview

The BX 18/18E Micro PLC Unit (MPU) includes fourteen different versions having the same appearance and basic features. All units have 10 discrete input points and 8 discrete output points built-in. Units with DC inputs have 10 selectable high-speed inputs and units with DC outputs have 4 selectable high-speed outputs. All MPUs can expand their I/O capacity with the BRX Expansion Modules, allowing for more flexibility while keeping control cost down. BX 18E units additionally have an Ethernet port as well as 1 analog input and 1 analog output built-in that are current/voltage selectable within the software.

BX 18/18E MPUs are divided into two distinct groups, BX 18 and BX 18E. The BX 18 MPUs have no built-in analog I/O or Ethernet port. The BX 18E MPUs have all the features of the BX 18, plus built-in analog I/O and an Ethernet port.



**BX 18 Micro PLC Unit (MPU) -
No Built-in Analog or Ethernet**



**BX 18E Micro PLC Unit (MPU) with
Built-in Analog and Ethernet Port**

BX 18 MPUs General Specifications



BX 18 Micro PLC Unit (MPU)
No Built-in Analog or Ethernet

- 18 discrete I/O points: 10 input, 8 output
- No built-in analog I/O points
- Models with DC inputs:
 - have 10 high-speed inputs rated up to 250kHz
 - accept 12–24 nominal voltage, AC or DC
 - can be wired as sinking or sourcing
- Models with AC inputs can accept 120–240 nominal voltages
- Output types available are DC sinking, DC sourcing, and relay
- Models with DC outputs have 4 high-speed outputs rated up to 250kHz
- Support for up to 8 additional Expansion Modules as long as the power budget is not exceeded.

The following table shows the available BX 18 MPUs.

BX 18 MPUs				
Part Number	External Power	Discrete Input	Discrete Output	Expansion Modules
BX-DM1-18ED1	120–240 VAC	10 High-Speed, DC Sinking or Sourcing	4 High-Speed 4 Standard DC Sinking	8, as long as the MPU power budget is not exceeded
BX-DM1-18ED1-D	12–24 VDC			
BX-DM1-18ED2	120–240 VAC			
BX-DM1-18ED2-D	12–24 VDC			
BX-DM1-18ER	120–240 VAC			
BX-DM1-18ER-D	12–24 VDC			
BX-DM1-18AR	120–240 VAC		10 Standard AC	

BX 18E MPUs General Specifications



BX 18E Micro PLC Unit (MPU) with Built-in Analog and Ethernet Port

- 18 Discrete I/O points: 10 inputs, 8 outputs
- All units have 1 analog input and 1 analog output (current/voltage software selectable)
- All units have built-in Ethernet port, 10/100 Mbps
- Models with DC inputs:
 - have 10 high-speed inputs rated up to 250kHz
 - accept 12–24 nominal voltages, AC or DC
 - can be wired as sinking or sourcing
- Models with AC inputs can accept 120–240 nominal voltages
- Output types available are DC sinking, DC sourcing, and relay
- Models with DC outputs have 4 high-speed outputs rated up to 250kHz
- Support for 8 additional Expansion Modules

The following table shows the available BX 18E MPUs.

BX 18E MPUs							
Part Number	External Power	Discrete Input	Discrete Output	Analog *		Expansion Modules	
				Input	Output		
BX-DM1E-18ED13	120–240 VAC	10 High-Speed, DC Sinking or Sourcing	4 High-Speed 4 Standard DC sinking	1 Current or Voltage	1 Current or Voltage	8	
BX-DM1E-18ED13-D	12–24 VDC		4 High-Speed 4 Standard DC sourcing				
BX-DM1E-18ED23	120–240 VAC						8 Form A relay
BX-DM1E-18ED23-D	12–24 VDC						
BX-DM1E-18ER3	120–240 VAC		10 Standard AC				
BX-DM1E-18ER3-D	12–24 VDC						
BX-DM1E-18AR3	120–240 VAC						

* Analog can be current or voltage software selectable per channel.

BX 18/18E MPU Wiring Termination Selection

The BX 18/18E MPUs ship without terminal blocks. This allows you to select the termination type that best suits your application. There are several wiring options available, including removable screw terminal connectors, removable spring clamp terminal connectors and pre-wired **ZIP**Link cable solutions.

Terminal Block Connectors

The terminal block connectors are provided in kits and can be ordered as a single part number. Each kit contains all the terminal block connectors required: (3) 5-pin 5mm terminal blocks (BX-RTB05), (2) 6-pin 5mm terminal blocks (BX-RTB06), and (1) 3-pin 5mm terminal block (BX-RTB03).

The BX 18/18E MPUs terminals are configured into groups of 5 inputs and 4 outputs each with an isolated common, e.g., inputs X0–X4 are grouped with their common terminal. On the BX 18E MPU the analogs are grouped as 3 terminals consisting of 1 input, 1 output and a shared isolated analog common. The I/O termination groups are isolated such that a single group connector can be removed without affecting other groups of I/O or the external power source.

The terminal block connector kit part numbers and connector specifications are listed in the table below.

Terminal Block Connector Specifications		
Kit Part Number	BX-RTB18	BX-RTB18-1
Connector Type	Screw Type-90 degree	Spring Clamp a Type-180 degree
Wire Exit	180 degree	180 degree
Pitch	5.0 mm	5.0 mm
Screw Size	M2.5	N/A
Recommended Screw Torque	< 3.98 lb·in (0.45 N·m)	N/A
Screwdriver Blade Width	3.5 mm	3.5 mm
Wire Gauge (Single Wire)	28–12 AWG	28–14 AWG
Wire Gauge (Dual Wire)	28–16 AWG	28–16 AWG (Dual wire ferrule required)
Wire Strip Length	0.3 in (7.5 mm)	0.37 in (9.5 mm)
Equiv. Dinkle P/N	5ESDV-0nP-BK*	5ESDSR-0nP-BK*

* Replace n with: (3) 3-terminal, (5) 5-terminal or (6) for 6-terminal.

BX-RTB18 Screw Terminal Block Kit

This terminal block kit has 90 degree screw terminal blocks. Wire is 180 degree pass through.



BX-RTB18-1 Spring Terminal Block Kit

This terminal block kit has Spring Clamp wire terminal blocks with 180 degree wire pass through.

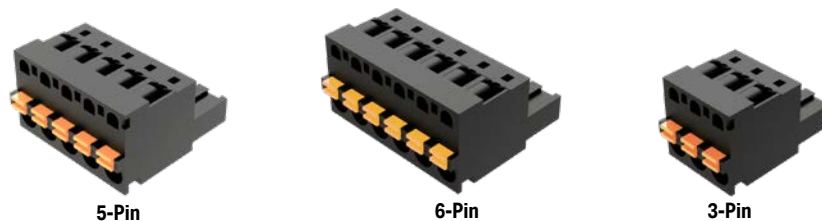

Replacement terminal blocks can be ordered online at: www.AutomationDirect.com. Single replacement terminal blocks are listed in table below.

Replacement Terminal Blocks		
	BX-RTB18	BX-RTB18-1
3-pin	BX-RTB03	BX-RTB03-1
5-pin	BX-RTB05	BX-RTB05-1
6-pin	BX-RTB06	BX-RTB06-1

ZIPLink Prewired Cable Solutions

ZIPLinks eliminate the normally tedious process of wiring between devices by utilizing prewired cables and DIN rail mount connector modules. ZIPLinks are as simple as plugging in a cable connector at either end or terminating wires at only one end. Prewired cables keep installation clean and efficient, using less space at a fraction of the cost of standard terminal blocks. ZIPLink prewired cables can connect directly to a ZIPLink remote terminal block module or with the pigtail option, allowing for a convenient solution to wire the BRX platform to 3rd party devices. For the BX 18/18E MPUs, two (2) cables and two (2) ZIPLink feedthrough modules are needed to connect all the wiring termination points.

There are two (2) feedthrough module options available, the ZL-RTB20 and the ZL-RTB20-1. The ZL-RTB20 is a standard feedthrough remote terminal module while the RTB20-1 is a feedthrough remote terminal block having a more compact footprint, requiring less space in the control cabinet.

The ZIPLink system options for the BX 18/18E MPUs are listed in the table below.

BX 18/18E ZIPLink Selector					
Part Number	Module Type	Module Part No.	Max Qty Needed	Cable Part No.*	Max Qty Needed
BX-DM1-18ED1	Feedthrough	ZL-RTB20, (standard) -OR- ZL-RTB20-1 (compact)	2	ZL-BX-CBL15 ZL-BX-CBL15-1 ZL-BX-CBL15-2	2
BX-DM1-18ED1-D					
BX-DM1-18ED2					
BX-DM1-18ED2-D					
BX-DM1-18ER					
BX-DM1-18ER-D					
BX-DM1-18AR					
BX-DM1E-18ED13					
BX-DM1E-18ED13-D					
BX-DM1E-18ED23					
BX-DM1E-18ED23-D					
BX-DM1E-18ER3					
BX-DM1E-18ER3-D					
BX-DM1E-18AR3					

* Select the cable length: Blank = 0.5 m, -1 = 1.0 m, -2 = 2.0 m.
Available pigtail cables: ZL-BX-CBL15-1P = 1.0 m, ZL-BX-CBL15-2P = 2.0 m.

ZIPLink Prewired Cables

Custom molded **ZIPLink** prewired cables allow for fast and easy connection of field wiring and remote I/O to the BRX platform. The prewired cables are available in 0.5 meter, 1 meter and 2 meter lengths. Pigtail cables are used to connect the BRX platform directly to third-party devices, lowering your wiring cost and time. The pigtail cables are available in 1 meter and 2 meter lengths.



ZL-BX-CBL20
ZIPLink Prewired Cable



ZL-BX-CBL20-1P
ZIPLink Pigtail Cable

ZIPLink Remote Feedthrough Modules

Feedthrough modules provide low-cost and compact field wiring screw termination solutions for quickly connecting with the BRX platform. There are 2 modules available for use with the BRX platform. The ZL-RTB20 and the ZL-RTB20-1. The ZL-RTB20 is a standard 2 row, 20-pin, DIN rail mountable feedthrough module. The ZL-RTB20-1 is a compact 3 row, 24-pin DIN rail mountable feedthrough module with a smaller footprint design.

The **ZIPLink** remote feedthrough module specifications are listed in the table below.

ZIPLink Module Specifications		
Part Number	ZL-RTB20 (Maximum of 2 Needed)	ZL-RTB20-1 (Maximum of 2 Needed)
Number of positions	20 screw terminals, 2 rows	24 screw terminals, 3 rows
Screwdriver Width	1/8 in (3.8 mm) maximum	
Screw Torque	4.4 lb-in (0.5 N·m)	



ZL-RTB20



ZL-RTB20-1

ZIPLink System Examples

BX 18 MPU with *ZIPLink* pre-wired cables and ZL-RTB20 feedthrough modules.



BX 18 MPU with *ZIPLink* pigtail cables installed.



BX 18 Micro PLC Units (MPUs)

BX-DM1-18ED1 Wiring

This MPU is made up of 18 discrete I/O points. The connections are grouped as follows:

- 10 discrete inputs - sinking/sourcing; rated for 12–24 VAC/VDC. They are located along the bottom of the unit; configured in two (2) groups of 6 terminals, each comprised of 5 inputs and an isolated common.
- 8 discrete outputs - sinking; rated at 12–24 VDC. They are located along the top of the unit starting to the right of the 24VDC auxiliary output terminals. The outputs are configured in two (2) groups of 5 terminals, each comprised of 4 outputs and an isolated common.

This MPU requires an external 120–240 VAC power supply. The AC power supply connection and the 24VDC auxiliary output supply terminals are located on the top left side of the unit.



WARNING: No analog I/O is included on this unit. The 3 terminals to the right of the inputs are not used. These terminals are not internally connected. DO NOT CONNECT ANYTHING TO THESE TERMINALS!



NOTE: Eight (8) Expansion Modules can be connected to extend I/O capacity, as long as the MPU power budget is not exceeded.

BX-DM1-18ED1 Wiring, Continued

Power Supply Specifications

Power Supply Specifications	
Nominal Voltage Range	120–240 VAC
Input Voltage Range (Tolerance)	85–264 VAC
Rated Operating Frequency	47–63 Hz
Maximum Input Power	40VA
Cold Start Inrush Current	1.5 A, 2ms
Maximum Inrush Current (Hot Start)	1.5 A, 2ms
Internal Input Fuse Protection	Micro fuse 250V, 2A Non-replaceable
Acceptable External Power Drop Time	10ms
Under Input Voltage Lock-out	80VAC
Input Transient Protection	Input choke and line filter
Heat Dissipation	16.1 W Max
Isolated User 24VDC Output	24VDC @ 0.3 A max, <1V P-P Ripple, Integrated self-resetting short circuit protection
Voltage Withstand (dielectric)	1500VAC Power Inputs to Ground applied for 1 minute 1500VAC Ground to 24VDC Output applied for 1 minute
Insulation Resistance	>10MΩ @ 500VDC
Software Version Required	Do-more! Designer version 2.0 or later

Power Supply Connections

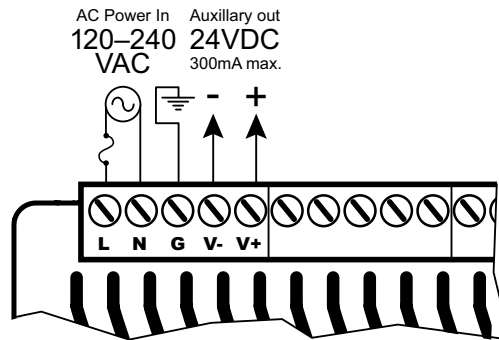

WARNING: Do not exceed the 24VDC auxiliary power supply load limit of 300mA.



WARNING: The BRX System **MUST** have a proper earth ground. Do not operate the BRX MPU without proper earth grounding.

BX-DM1-18ED1 Wiring, Continued

Discrete Input Specifications

Discrete Input Specifications		
Input Type	Sink/Source	
Total Inputs per Module	10	
Commons	2 (5 points/common) Isolated	
Nominal Voltage Range	12–24 VAC/VDC	
Input Voltage Range	9–30 VAC/VDC	
Maximum Voltage	30 VAC/VDC	
DC Frequency	0–250 kHz - High-speed	
Minimum Pulse Width	0.5 μ s - High-speed	
AC Frequency	47–63 Hz ²	
Input Impedance	3k Ω @ 24VDC	
Input Current (typical)	6mA @ 24 VAC/VDC	
Maximum Input Current	12mA @ 30 VAC/VDC	
ON Voltage Level	> 9.0 VAC/VDC	
OFF Voltage Level	< 2.0 VAC/VDC	
Maximum OFF Current	1.5 mA	
Status Indicators	Logic Side, Green	
Input Details		
Input Type	High-Speed DC	Standard ¹
Location	X0...X9	
OFF to ON Response	DC	< 2 μ s
	AC	– 10ms ²
ON to OFF Response	DC	< 2 μ s
	AC	– 10ms ²
Maximum Switching Frequency	DC	250kHz
	AC	~ 30Hz

1. All Inputs may be used as standard inputs or high speed inputs independently.
2. 60Hz to 240Hz filter should be set in the software when using an AC line signal.

BX-DM1-18ED1 Wiring, Continued

Discrete Input Connection Options

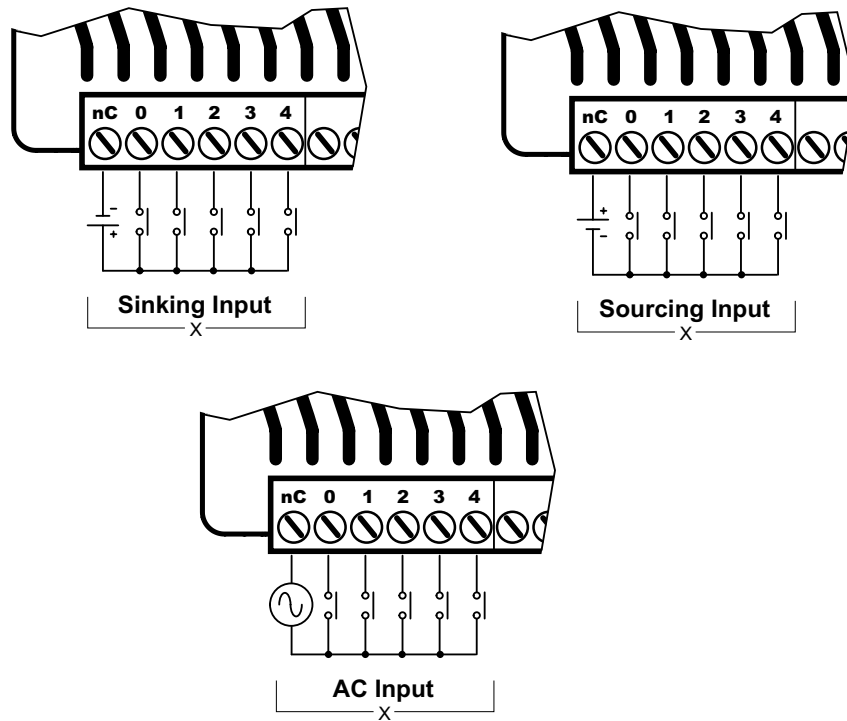

Discrete Input Internal Circuitry *

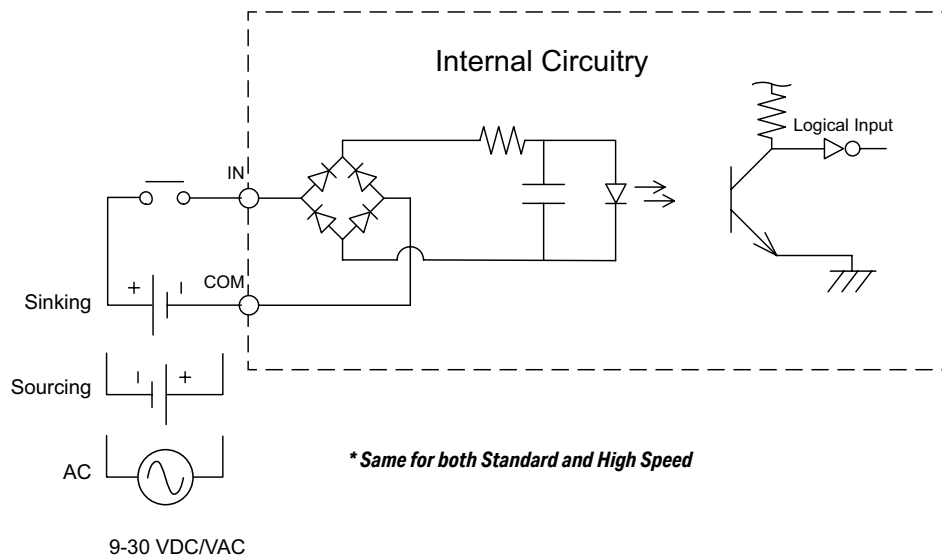

BX-DM1-18ED1 Wiring, Continued

Discrete Output Specifications

Discrete Output Specifications		
Output Type	Sinking	
Total Outputs per Module	8	
Commons	2 (4 points/common) Isolated	
Maximum Current per Common	2A	
Nominal Voltage Range	12–24 VDC	
Operating Voltage Range	5–36 VDC	
Maximum Voltage	36VDC	
Minimum Output Current	0.1 mA @ 24VDC	
Maximum Output Current	0.5 A per output No derating over temperature range	
Maximum Inrush Current	5A for 50ms	
Maximum Leakage Current	10 μ A	
ON Voltage Drop	0.05 VDC	
Status Indicators	Logic Side, Green	
Output Details		
Output Type	High-Speed	Standard ¹
Location	Y0...Y3	Y4...Y7
OFF to ON Response	< 2 μ s	< 5ms
ON to OFF Response	< 2 μ s	< 2ms
Maximum Switching Frequency	1m cable - 250kHz 10m cable - 100kHz	~ 100Hz
Overcurrent, Short Circuit Protection and Short to Ground	Current limit by Common Group, self-resetting	N/A
Overcurrent Trip Level ²	Between 4A and 8A	N/A
Fuse Type	User-supplied external fuse	

- 1. All outputs may be used as standard outputs. Only the first 4 outputs (Y0...Y3) are capable of high-speed DC operation.**
- 2. When the high-speed outputs are in an overcurrent situation, the Common terminal Red LED is on. The output LEDs will remain operational even though the output circuitry is turned off and no power is flowing. This condition is not reported to the CPU.**

BX-DM1-18ED1 Wiring, continued

Discrete Output Connection Options

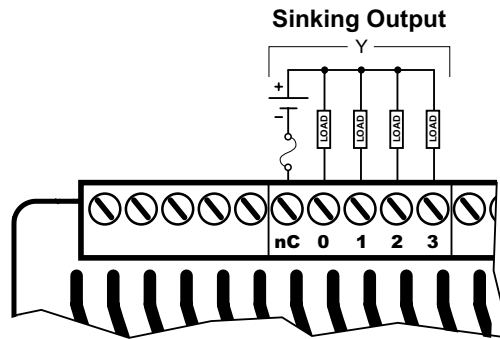

Discrete Standard Output Internal Circuitry

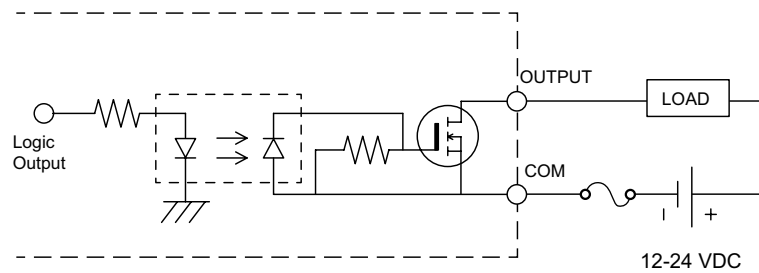

Discrete High-Speed Output Internal Circuitry

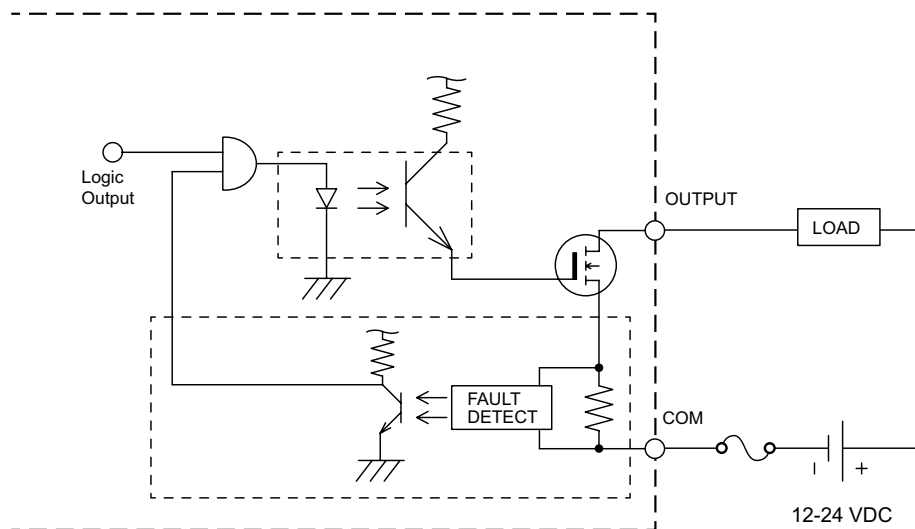

NOTE: When the high speed outputs are in an overcurrent situation, the Common terminal Red LED is on. The output LEDs will remain operational even though the output circuitry is turned off and no power is flowing. This condition is not reported to the CPU.

BX-DM1-18ED1-D Wiring

This MPU is made up of 18 discrete I/O points. The connections are grouped as follows:

- 10 discrete inputs - sinking/sourcing; rated for 12–24 VAC/VDC. They are located along the bottom of the unit; configured in two (2) groups of six (6) terminals, each comprised of five (5) inputs and an isolated common.
- 8 discrete outputs - sinking; rated at 12–24 VDC. They are located along the top of the unit starting to the right of the 24VDC external power supply terminals. The outputs are configured in two (2) groups of five (5) terminals, each comprised of four (4) outputs and an isolated common.

The MPU requires an external 12–24 VDC power supply. The DC power supply connection is located on the top left side of the unit. There is no 24VDC auxiliary output supply.



WARNING: No analog I/O is included on this unit. The 3 terminals to the right of the inputs are not used. These terminals are not internally connected. DO NOT CONNECT ANYTHING TO THESE TERMINALS!



BX-DM1-18ED1-D



NOTE: Eight (8) Expansion Modules can be connected to extend I/O capacity, as long as the MPU power budget is not exceeded.

BX-DM1-18ED1-D Wiring, Continued

Power Supply Specifications

Power Supply Specifications	
Nominal Voltage Range*	12–24 VDC
Input Voltage Range (Tolerance)*	10–36 VDC
Maximum Input Voltage Ripple	< ±10%
Maximum Input Power	30W
Cold Start Inrush Current	5A, 2ms
Maximum Inrush Current (Hot Start)	5A, 2ms
Internal Input Protection	Reverse polarity protection and undervoltage lockout via transistor circuit
Acceptable External Power Drop Time	10ms
Under Input Voltage Lock-out	<9VDC
Heat Dissipation	13.9 W Max
Isolated User 24VDC Output	None
Voltage Withstand (dielectric)	1500VAC power Inputs to ground applied for 1 minute
Insulation Resistance	>10MΩ @ 500VDC
Software Version Required	Do-more! Designer version 2.0 or later

* Class 2 or LPS Power Supply required.

Power Supply Connections

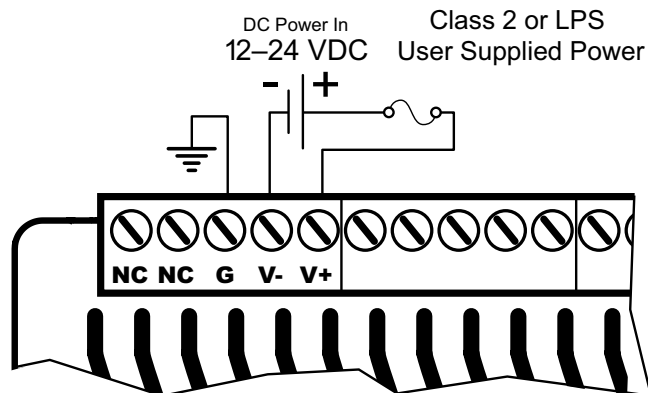

WARNING: No External AC power supply needed on this unit. The two terminals marked "NC" are not used. These terminals are not internally connected. **DO NOT CONNECT ANYTHING TO THESE TERMINALS!**



WARNING: The BRX System **MUST** have a proper earth ground. Do not operate the BRX MPU without proper earth grounding.

BX-DM1-18ED1-D Wiring, Continued

Discrete Input Specifications

Discrete Input Specifications		
Input Type	Sink/Source	
Total Inputs per Module	10	
Commons	2 (5 points/common) Isolated	
Nominal Voltage Range	12–24 VAC/VDC	
Input Voltage Range	9–30 VAC/VDC	
Maximum Voltage	30 VAC/VDC	
DC Frequency	0–250 kHz - High-speed	
Minimum Pulse Width	0.5 μ s - High-speed	
AC Frequency	47–63 Hz ²	
Input Impedance	3k Ω @ 24VDC	
Input Current (typical)	6mA @ 24 VAC/VDC	
Maximum Input Current	12mA @ 30 VAC/VDC	
ON Voltage Level	> 9.0 VAC/VDC	
OFF Voltage Level	< 2.0 VAC/VDC	
Maximum OFF Current	1.5 mA	
Status Indicators	Logic Side, Green	
Input Details		
Input Type	High-Speed DC	Standard ¹
Location	X0...X9	
OFF to ON Response	DC	< 2 μ s
	AC	– 10ms ²
ON to OFF Response	DC	< 2 μ s
	AC	– 10ms ²
Maximum Switching Frequency	DC	250kHz
	AC	~ 30Hz

- 1. All Inputs may be used as standard inputs or high speed inputs independently.*
- 2. 60Hz to 240Hz filter should be set in the software when using an AC line signal.*

BX-DM1-18ED1-D Wiring, Continued

Discrete Input Connection Options

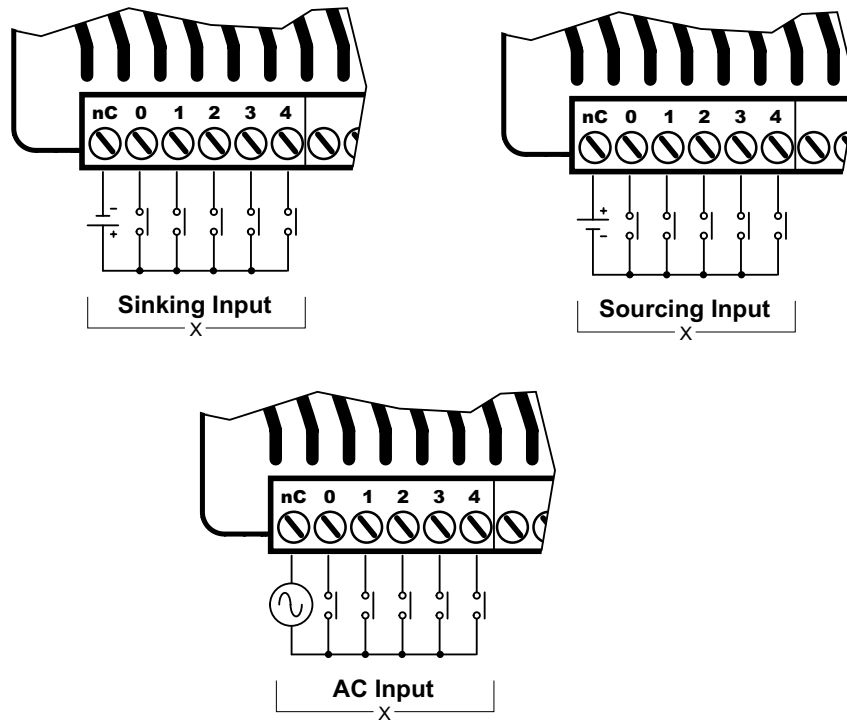

Discrete Input Internal Circuitry *

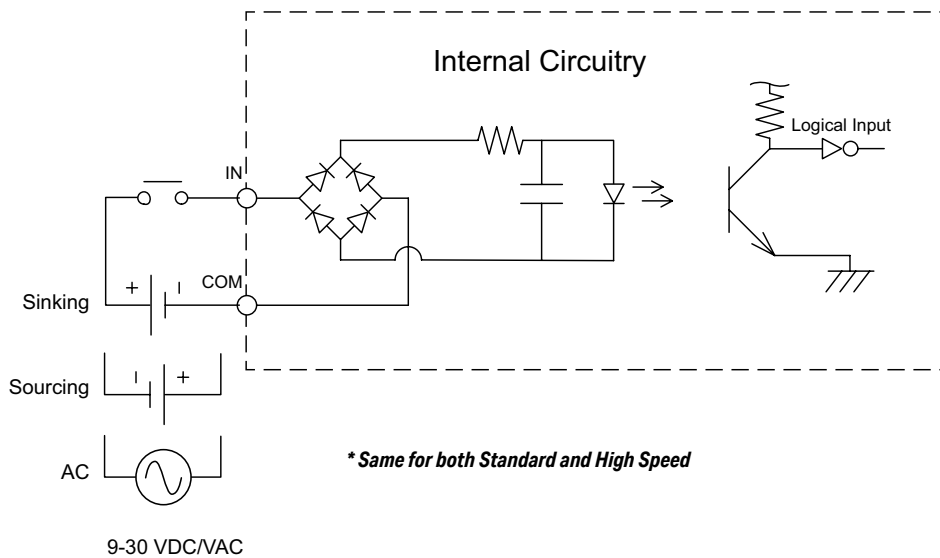

BX-DM1-18ED1-D Wiring, Continued

Discrete Output Specifications

Discrete Output Specifications		
Output Type	Sinking	
Total Outputs per Module	8	
Commons	2 (4 points/common) Isolated	
Maximum Current per Common	2A	
Nominal Voltage Range	12–24 VDC	
Operating Voltage Range	5–36 VDC	
Maximum Voltage	36VDC	
Minimum Output Current	0.1 mA @ 24VDC	
Maximum Output Current	0.5 A per output No derating over temperature range	
Maximum Inrush Current	5A for 50ms	
Maximum Leakage Current	10 μ A	
ON Voltage Drop	0.05 VDC	
Status Indicators	Logic Side, Green	
Output Details		
Output Type	High-Speed	Standard ¹
Location	Y0...Y3	Y4...Y7
OFF to ON Response	< 2 μ s	< 5ms
ON to OFF Response	< 2 μ s	< 2ms
Maximum Switching Frequency	1m cable - 250kHz 10m cable - 100kHz	~ 100Hz
Overcurrent, Short Circuit Protection and Short to Ground	Current limit by Common Group, self-resetting	N/A
Overcurrent Trip Level ²	Between 4A and 8A	N/A
Fuse Type	User-supplied external fuse	

- All outputs may be used as standard outputs. Only the first 4 outputs (Y0...Y3) are capable of high-speed DC operation.*
- When the high-speed outputs are in an overcurrent situation, the Common terminal Red LED is on. The output LEDs will remain operational even though the output circuitry is turned off and no power is flowing. This condition is not reported to the CPU.*

BX-DM1-18ED1-D Wiring, Continued

Discrete Output Connection Options

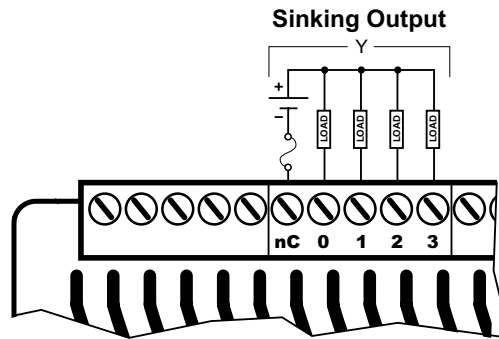

Discrete Standard Output Internal Circuitry

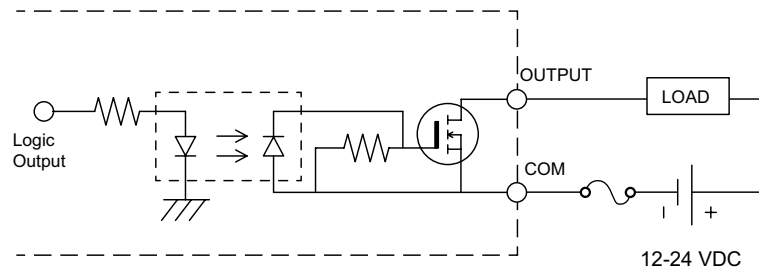

Discrete High-Speed Output Internal Circuitry

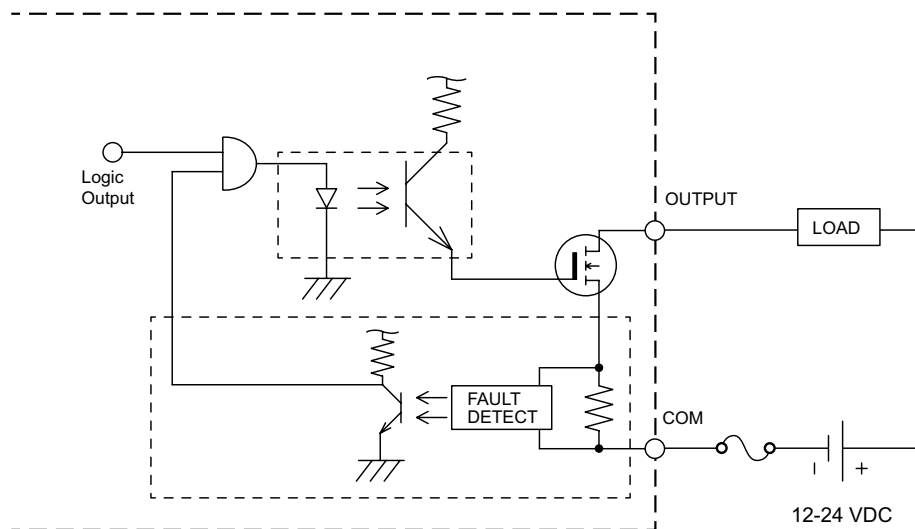

NOTE: When the high speed outputs are in an overcurrent situation, the Common terminal Red LED is on. The output LEDs will remain operational even though the output circuitry is turned off and no power is flowing. This condition is not reported to the CPU.

BX-DM1-18ED2 Wiring

This MPU is made up of 18 discrete I/O points. The connections are grouped as follows:

- 10 discrete inputs - sinking/sourcing; rated for 12–24 VAC/VDC. They are located along the bottom of the unit; configured in two (2) groups of 6 terminals, each comprised of 5 inputs and an isolated common.
- 8 discrete outputs - sourcing; rated at 12–24 VDC. They are located along the top of the unit starting to the right of the 24VDC auxiliary output terminals. The outputs are configured in two (2) groups of 5 terminals, each comprised of 4 outputs and an isolated common.

This MPU requires an external 120–240 VAC power supply. The AC power supply connection and the 24VDC auxiliary output supply terminals are located on the top left side of the unit.



WARNING: No analog I/O is included on this unit. The 3 terminals to the right of the inputs are not used. These terminals are not internally connected. DO NOT CONNECT ANYTHING TO THESE TERMINALS!



BX-DM1-18ED2



NOTE: Eight (8) Expansion Modules can be connected to extend I/O capacity, as long as the MPU power budget is not exceeded.

BX-DM1-18ED2 Wiring, Continued

Power Supply Specifications

Power Supply Specifications	
Nominal Voltage Range	120–240 VAC
Input Voltage Range (Tolerance)	85–264 VAC
Rated Operating Frequency	47–63 Hz
Maximum Input Power	40VA
Cold Start Inrush Current	1.5 A, 2ms
Maximum Inrush Current (Hot Start)	1.5 A, 2ms
Internal Input Fuse Protection	Micro fuse 250V, 2A Non-replaceable
Acceptable External Power Drop Time	10ms
Under Input Voltage Lock-out	80VAC
Input Transient Protection	Input choke and line filter
Heat Dissipation	16.1 W Max
Isolated User 24VDC Output	24VDC @ 0.3 A max, <1V P-P Ripple, Integrated self-resetting short circuit protection
Voltage Withstand (dielectric)	1500VAC Power Inputs to Ground applied for 1 minute 1500VAC Ground to 24VDC Output applied for 1 minute
Insulation Resistance	>10MΩ @ 500VDC
Software Version Required	Do-more! Designer version 2.0 or later

Power Supply Connections

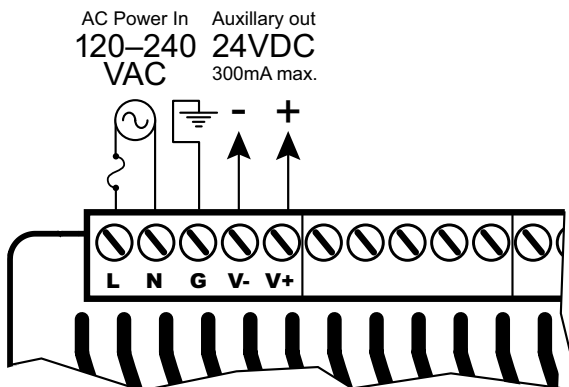

WARNING: Do not exceed the 24VDC auxiliary power supply load limit of 300mA.



WARNING: The BRX System **MUST** have a proper earth ground. Do not operate the BRX MPU without proper earth grounding.

BX-DM1-18ED2 Wiring, Continued

Discrete Input Specifications

Discrete Input Specifications		
Input Type	Sink/Source	
Total Inputs per Module	10	
Commons	2 (5 points/common) Isolated	
Nominal Voltage Range	12–24 VAC/VDC	
Input Voltage Range	9–30 VAC/VDC	
Maximum Voltage	30 VAC/VDC	
DC Frequency	0–250 kHz - High-speed	
Minimum Pulse Width	0.5 μ s - High-speed	
AC Frequency	47–63 Hz ²	
Input Impedance	3k Ω @ 24VDC	
Input Current (typical)	6mA @ 24 VAC/VDC	
Maximum Input Current	12mA @ 30 VAC/VDC	
ON Voltage Level	> 9.0 VAC/VDC	
OFF Voltage Level	< 2.0 VAC/VDC	
Maximum OFF Current	1.5 mA	
Status Indicators	Logic Side, Green	
Input Details		
Input Type	High-Speed DC	Standard ¹
Location	X0...X9	
OFF to ON Response	DC	< 2 μ s
	AC	– 10ms ²
ON to OFF Response	DC	< 2 μ s
	AC	– 10ms ²
Maximum Switching Frequency	DC	250kHz
	AC	~ 30Hz

1. All Inputs may be used as standard inputs or high speed inputs independently.
2. 60Hz to 240Hz filter should be set in the software when using an AC line signal.

BX-DM1-18ED2 Wiring, Continued

Discrete Input Connection Options

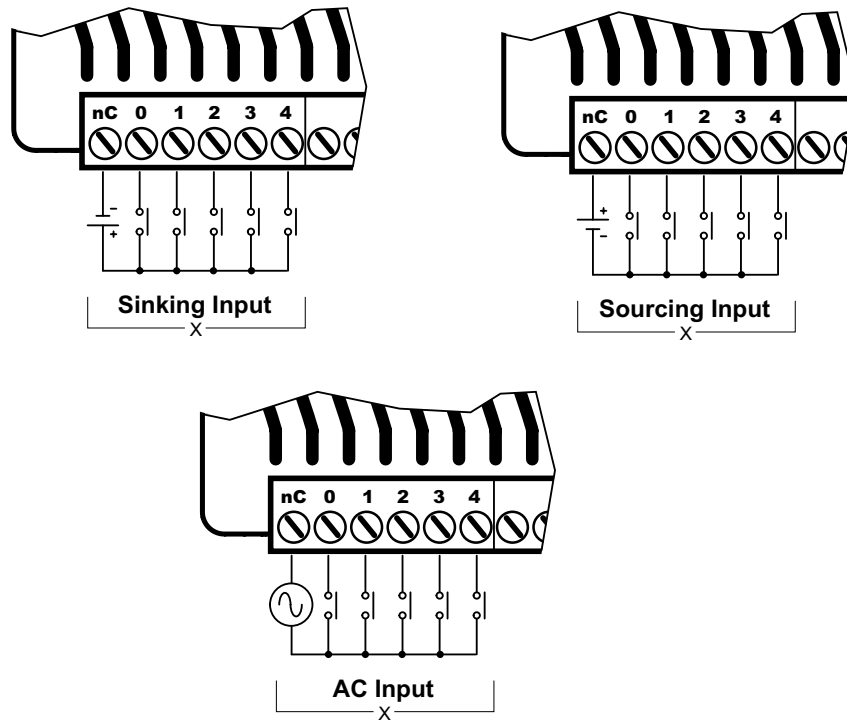

Discrete Input Internal Circuitry *

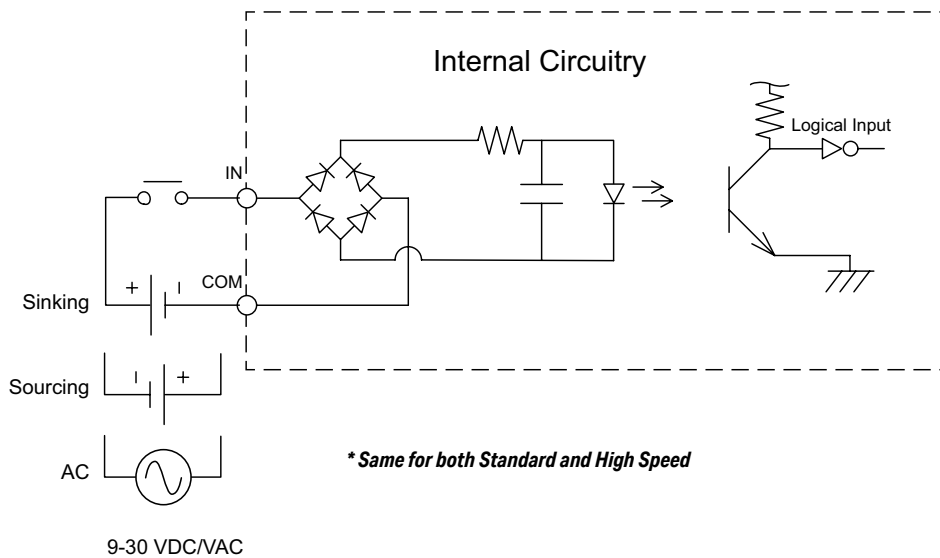

BX-DM1-18ED2 Wiring, Continued

Discrete Output Specifications

Discrete Output Specifications		
Output Type	Sourcing	
Total Outputs per Module	8	
Commons	2 (4 points/common) Isolated	
Maximum Current per Common	2A	
Nominal Voltage Range	12–24 VDC	
Operating Voltage Range	5–36 VDC	
Maximum Voltage	36VDC	
Minimum Output Current	0.1 mA @ 24VDC	
Maximum Output Current	0.5 A per output No derating over temperature range	
Maximum Inrush Current	5A for 50ms	
Maximum Leakage Current	10 μ A	
ON Voltage Drop	0.05 VDC	
Status Indicators	Logic Side, Green	
Output Details		
Output Type	High-Speed	Standard ¹
Location	Y0...Y3	Y4...Y7
OFF to ON Response	< 2 μ s	< 5ms
ON to OFF Response	< 2 μ s	< 2ms
Maximum Switching Frequency	1m cable - 250kHz 10m cable - 100kHz	~ 100Hz
Overcurrent, Short Circuit Protection and Short to Ground	Current limit by Common Group, self-resetting	N/A
Overcurrent Trip Level ²	Between 4A and 8A	N/A
Fuse Type	User-supplied external fuse	

- 1. All outputs may be used as standard outputs. Only the first 4 outputs (Y0...Y3) are capable of high-speed DC operation.**
- 2. When the high-speed outputs are in an overcurrent situation, the Common terminal Red LED is on. The output LEDs will remain operational even though the output circuitry is turned off and no power is flowing. This condition is not reported to the CPU.**

BX-DM1-18ED2 Wiring, Continued

Discrete Output Connection Options

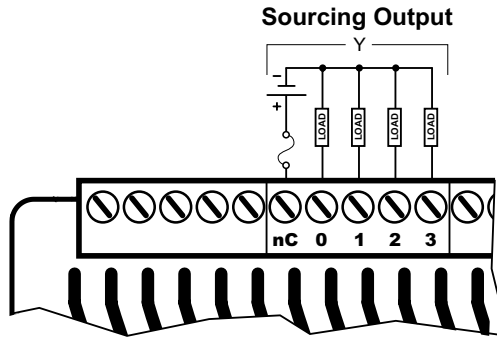

Discrete Standard Output Internal Circuitry

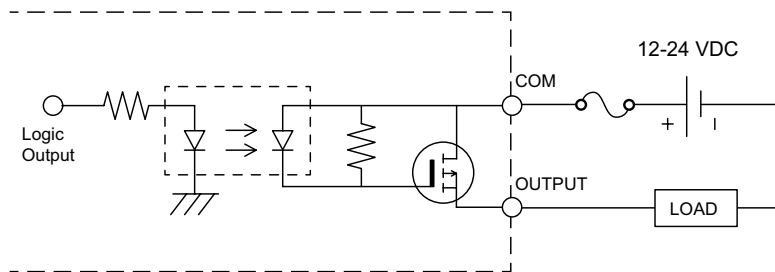

Discrete High-Speed Output Internal Circuitry

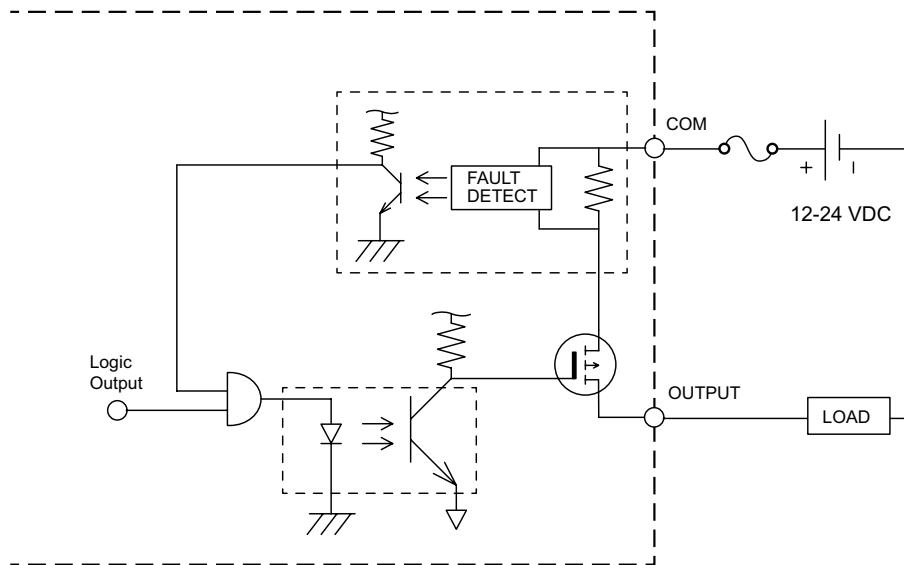

NOTE: When the high speed outputs are in an overcurrent situation, the Common terminal Red LED is on. The output LEDs will remain operational even though the output circuitry is turned off and no power is flowing. This condition is not reported to the CPU.

BX-DM1-18ED2-D Wiring

This MPU is made up of 18 discrete I/O points. The connections are grouped as follows:

- 10 discrete inputs - sinking/sourcing; rated for 12–24 VAC/VDC. They are located along the bottom of the unit; configured in two (2) groups of 6 terminals, each comprised of 5 inputs and an isolated common.
- 8 discrete outputs - sourcing; rated at 12–24 VDC. They are located along the top of the unit starting to the right of the 24VDC external power supply terminals. The outputs are configured in two (2) groups of 5 terminals, each comprised of 4 outputs and an isolated common..

This MPU requires an external 12–24 VDC power supply. The DC power supply connection is located on the top left side of the unit. There is no 24VDC auxiliary output supply.



WARNING: No analog I/O is included on this unit. The 3 terminals to the right of the inputs are not used. These terminals are not internally connected. DO NOT CONNECT ANYTHING TO THESE TERMINALS!



BX-DM1-18ED2-D



NOTE: Eight (8) Expansion Modules can be connected to extend I/O capacity, as long as the MPU power budget is not exceeded.

BX-DM1-18ED2-D, Continued

Power Supply Specifications

Power Supply Specifications	
Nominal Voltage Range*	12–24 VDC
Input Voltage Range (Tolerance)*	10–36 VDC
Maximum Input Voltage Ripple	< ±10%
Maximum Input Power	30W
Cold Start Inrush Current	5A, 2ms
Maximum Inrush Current (Hot Start)	5A, 2ms
Internal Input Protection	Reverse polarity protection and undervoltage lockout via transistor circuit
Acceptable External Power Drop Time	10ms
Under Input Voltage Lock-out	<9VDC
Heat Dissipation	13.9 W Max
Isolated User 24VDC Output	None
Voltage Withstand (dielectric)	1500VAC power Inputs to ground applied for 1 minute
Insulation Resistance	>10MΩ @ 500VDC
Software Version Required	Do-more! Designer version 2.0 or later

* Class 2 or LPS Power Supply required.

Power Supply Connections

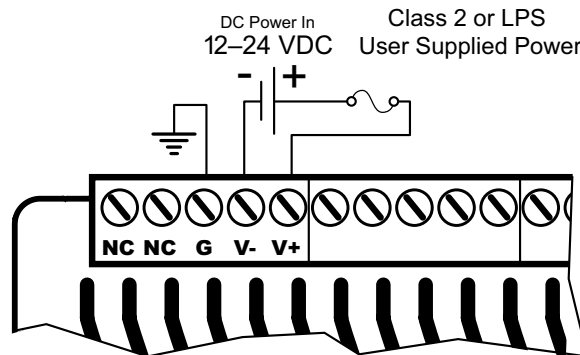

WARNING: No External AC power supply needed on this unit. The two terminals marked "NC" are not used. These terminals are not internally connected. **DO NOT CONNECT ANYTHING TO THESE TERMINALS!**



WARNING: The BRX System **MUST** have a proper earth ground. Do not operate the BRX MPU without proper earth grounding.

BX-DM1-18ED2-D Wiring, Continued

Discrete Input Specifications

Discrete Input Specifications		
Input Type	Sink/Source	
Total Inputs per Module	10	
Commons	2 (5 points/common) Isolated	
Nominal Voltage Range	12–24 VAC/VDC	
Input Voltage Range	9–30 VAC/VDC	
Maximum Voltage	30 VAC/VDC	
DC Frequency	0–250 kHz - High-speed	
Minimum Pulse Width	0.5 μ s - High-speed	
AC Frequency	47–63 Hz ²	
Input Impedance	3k Ω @ 24VDC	
Input Current (typical)	6mA @ 24 VAC/VDC	
Maximum Input Current	12mA @ 30 VAC/VDC	
ON Voltage Level	> 9.0 VAC/VDC	
OFF Voltage Level	< 2.0 VAC/VDC	
Maximum OFF Current	1.5 mA	
Status Indicators	Logic Side, Green	
Input Details		
Input Type	High-Speed DC	Standard ¹
Location	X0...X9	
OFF to ON Response	DC	< 2 μ s
	AC	– 10ms ²
ON to OFF Response	DC	< 2 μ s
	AC	– 10ms ²
Maximum Switching Frequency	DC	250kHz
	AC	~ 30Hz

- 1. All Inputs may be used as standard inputs or high speed inputs independently.*
- 2. 60Hz to 240Hz filter should be set in the software when using an AC line signal.*

BX-DM1-18ED2-D Wiring, Continued

Discrete Input Connection Options

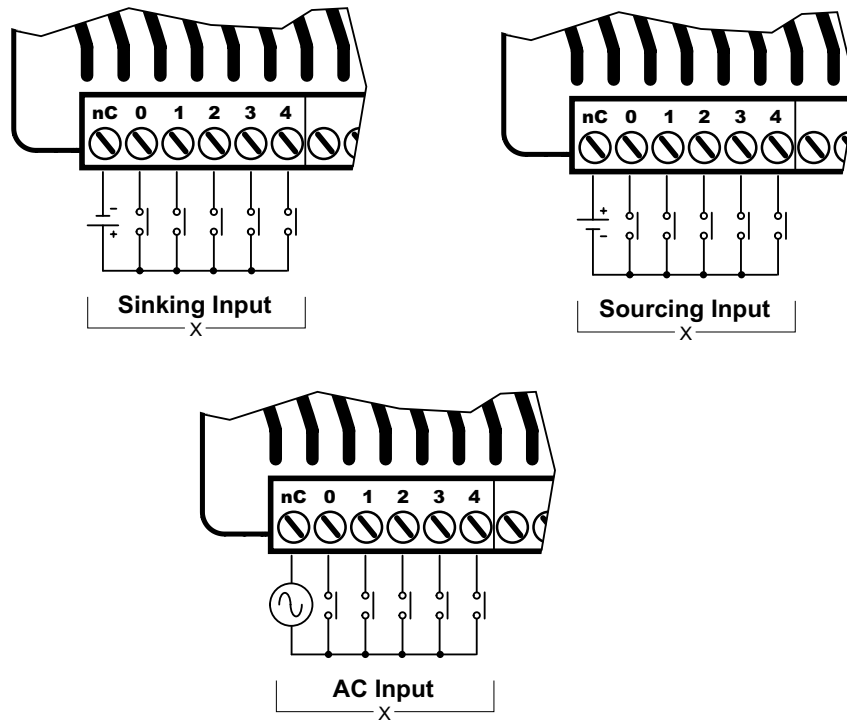

Discrete Input Internal Circuitry *

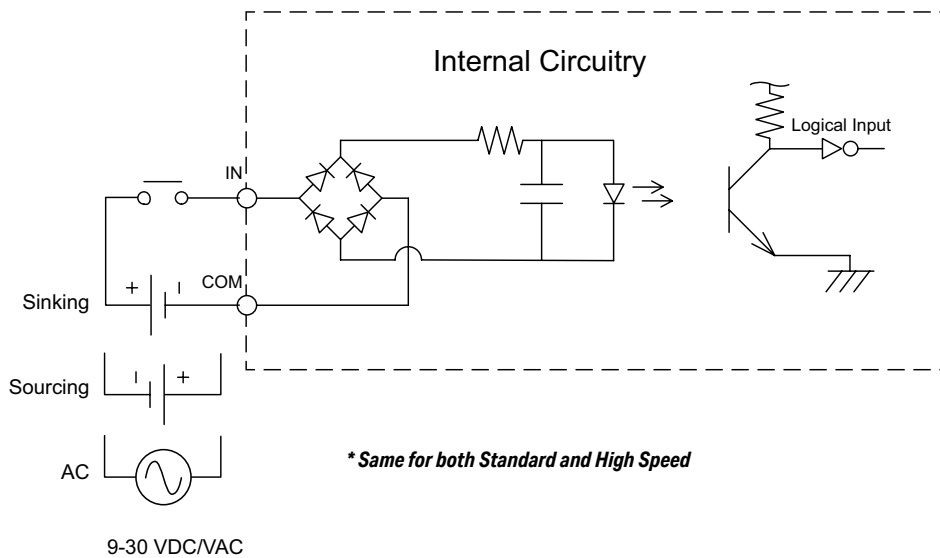

BX-DM1-18ED2-D Wiring, Continued

Discrete Output Specifications

Discrete Output Specifications		
Output Type	Sourcing	
Total Outputs per Module	8	
Commons	2 (4 points/common) Isolated	
Maximum Current per Common	2A	
Nominal Voltage Range	12–24 VDC	
Operating Voltage Range	5–36 VDC	
Maximum Voltage	36VDC	
Minimum Output Current	0.1 mA @ 24VDC	
Maximum Output Current	0.5 A per output No derating over temperature range	
Maximum Inrush Current	5A for 50ms	
Maximum Leakage Current	10 μ A	
ON Voltage Drop	0.05 VDC	
Status Indicators	Logic Side, Green	
Output Details		
Output Type	High-Speed	Standard ¹
Location	Y0...Y3	Y4...Y7
OFF to ON Response	< 2 μ s	< 5ms
ON to OFF Response	< 2 μ s	< 2ms
Maximum Switching Frequency	1m cable - 250kHz 10m cable - 100kHz	~ 100Hz
Overcurrent, Short Circuit Protection and Short to Ground	Current limit by Common Group, self-resetting	N/A
Overcurrent Trip Level ²	Between 4A and 8A	N/A
Fuse Type	User-supplied external fuse	

1. All outputs may be used as standard outputs. Only the first 4 outputs (Y0...Y3) are capable of high-speed DC operation.

2. When the high-speed outputs are in an overcurrent situation, the Common terminal Red LED is on. The output LEDs will remain operational even though the output circuitry is turned off and no power is flowing. This condition is not reported to the CPU.

BX-DM1-18ED2-D Wiring, Continued

Discrete Output Connection Options

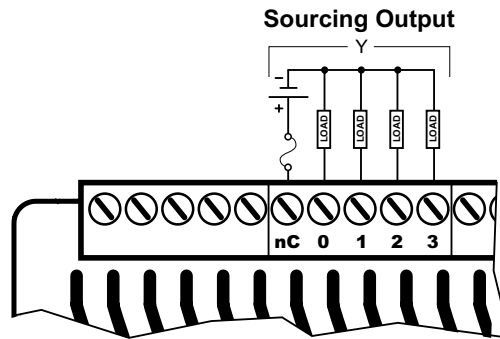

Discrete Standard Output Internal Circuitry

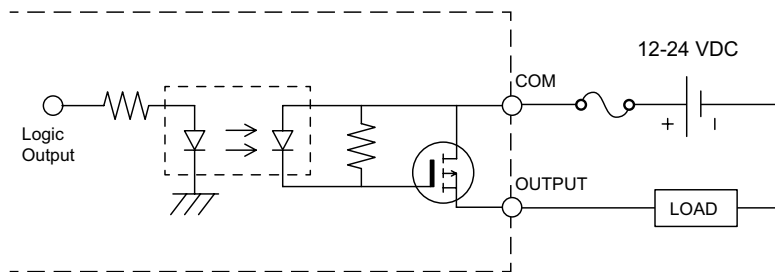

Discrete High-Speed Output Internal Circuitry

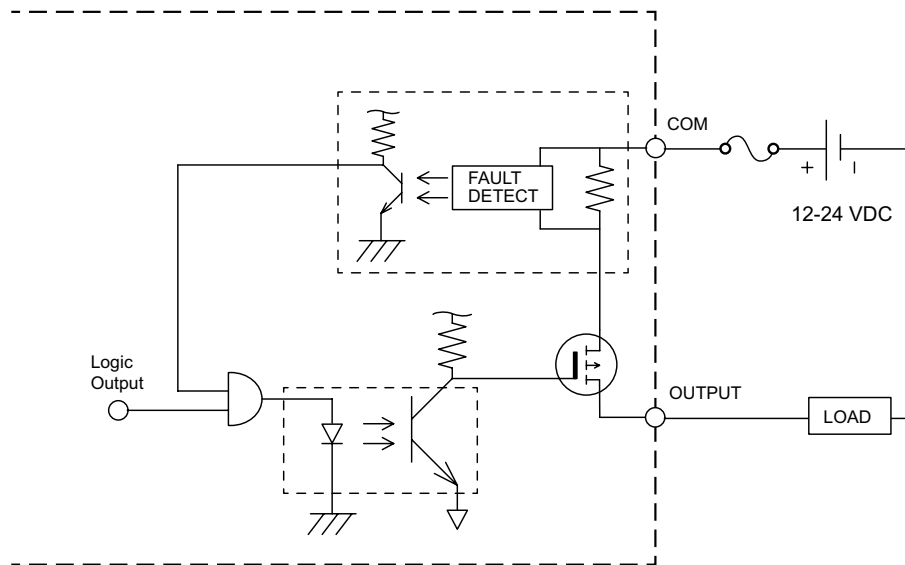

NOTE: When the high speed outputs are in an overcurrent situation, the Common terminal Red LED is on. The output LEDs will remain operational even though the output circuitry is turned off and no power is flowing. This condition is not reported to the CPU.

BX-DM1-18ER Wiring

This MPU is made up of 18 discrete I/O points. The connections are grouped as follows:

- 10 discrete inputs - sinking/sourcing; rated for 12–24 VAC/VDC. They are located along the bottom of the unit; configured in two (2) groups of 6 terminals, each comprised of 5 inputs and an isolated common.
- 8 discrete outputs - Form A Relay (SPST); rated 12–48 VDC/ 24–240 VAC. They are located along the top of the unit starting to the right of the 24VDC auxiliary output terminals. The outputs are configured in two (2) groups of 5 terminals, each comprised of 4 outputs and an isolated common.

This MPU requires an external 120–240 VAC power supply. The AC power supply connection and the 24VDC auxiliary output supply terminals are located on the top left side of the unit.



WARNING: No analog I/O is included on this unit. The 3 terminals to the right of the inputs are not used. These terminals are not internally connected. DO NOT CONNECT ANYTHING TO THESE TERMINALS!



BX-DM1-18ER



NOTE: Eight (8) Expansion Modules can be connected to extend I/O capacity, as long as the MPU power budget is not exceeded.

BX-DM1-18ER Wiring, Continued

Power Supply Specifications

Power Supply Specifications	
Nominal Voltage Range	120–240 VAC
Input Voltage Range (Tolerance)	85–264 VAC
Rated Operating Frequency	47–63 Hz
Maximum Input Power	40VA
Cold Start Inrush Current	1.5 A, 2ms
Maximum Inrush Current (Hot Start)	1.5 A, 2ms
Internal Input Fuse Protection	Micro fuse 250V, 2A Non-replaceable
Acceptable External Power Drop Time	10ms
Under Input Voltage Lock-out	80VAC
Input Transient Protection	Input choke and line filter
Heat Dissipation	19.3 W Max
Isolated User 24VDC Output	24VDC @ 0.3 A max, <1V P-P Ripple, Integrated self-resetting short circuit protection
Voltage Withstand (dielectric)	1500VAC Power Inputs to Ground applied for 1 minute 1500VAC Ground to 24VDC Output applied for 1 minute
Insulation Resistance	>10MΩ @ 500VDC
Software Version Required	Do-more! Designer version 2.0 or later

Power Supply Connections

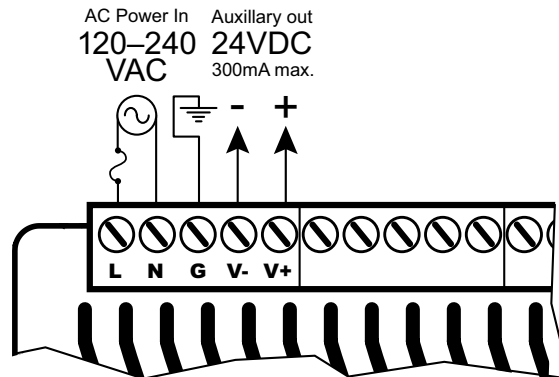

WARNING: Do not exceed the 24VDC auxiliary power supply load limit of 300mA.



WARNING: The BRX System **MUST** have a proper earth ground. Do not operate the BRX MPU without proper earth grounding.

BX-DM1-18ER Wiring, Continued

Discrete Input Specifications

Discrete Input Specifications		
Input Type	Sink/Source	
Total Inputs per Module	10	
Commons	2 (5 points/common) Isolated	
Nominal Voltage Range	12–24 VAC/VDC	
Input Voltage Range	9–30 VAC/VDC	
Maximum Voltage	30 VAC/VDC	
DC Frequency	0–250 kHz - High-speed	
Minimum Pulse Width	0.5 μ s - High-speed	
AC Frequency	47–63 Hz ²	
Input Impedance	3k Ω @ 24VDC	
Input Current (typical)	6mA @ 24 VAC/VDC	
Maximum Input Current	12mA @ 30 VAC/VDC	
ON Voltage Level	> 9.0 VAC/VDC	
OFF Voltage Level	< 2.0 VAC/VDC	
Maximum OFF Current	1.5 mA	
Status Indicators	Logic Side, Green	
Input Details		
Input Type	High-Speed DC	Standard ¹
Location	X0...X9	
OFF to ON Response	DC	< 2 μ s
	AC	– 10ms ²
ON to OFF Response	DC	< 2 μ s
	AC	– 10ms ²
Maximum Switching Frequency	DC	250kHz
	AC	~ 30Hz

1. All Inputs may be used as standard inputs or high speed inputs independently.
2. 60Hz to 240Hz filter should be set in the software when using an AC line signal.

BX-DM1-18ER Wiring, Continued

Discrete Input Connection Options

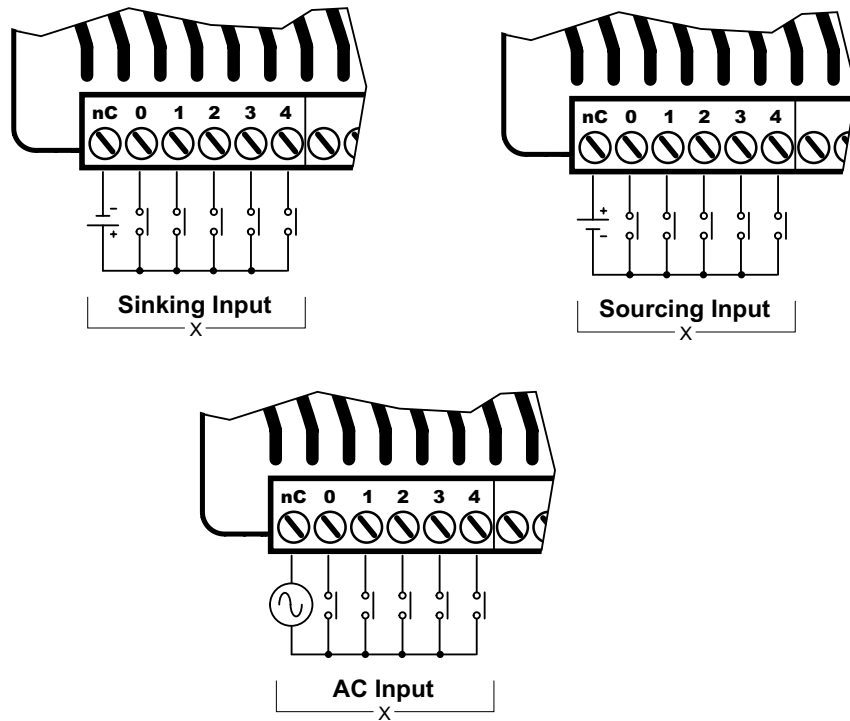

Discrete Input Internal Circuitry *

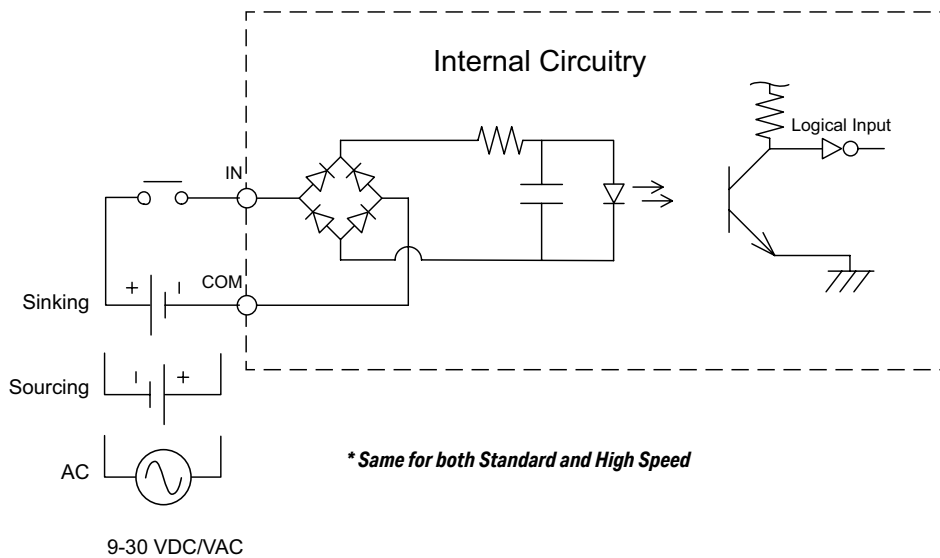

BX-DM1-18ER Wiring, Continued

Discrete Output Specifications

Discrete Output Specifications	
Output Type	Relay Form A (SPST)
Total Outputs per Module	8
Commons	2 (4 points/common) Isolated
Maximum Current per Common	8A
Nominal Voltage Range	12–48 VDC 24–240 VAC
Operating Voltage Range	5–60 VDC 5–264 VAC
Maximum Voltage	60VDC 264VAC
Minimum Output Current	0.1 mA @ 24VDC 0.1 mA @ 24VAC
Maximum Output Current	2A
Maximum Inrush Current	5A for 50ms
Maximum Leakage Current	1 μ A (DC), 300 μ A (AC) due to RC snubber circuit
ON Voltage Drop	0.2 V Max
Status Indicators	Logic Side, Green
Output Details	
Output Type	Standard
Location	Y0...Y7
ON-OFF Response	<10ms
OFF-ON Response	<10ms
Maximum Switching Frequency	10Hz
Relay Cycle Life	5 million operations
Mechanical Endurance	120,000 operations
Electrical Endurance	
Fuse Type	User-supplied external fuse

BX-DM1-18ER Wiring, Continued

Discrete Output Connection Options

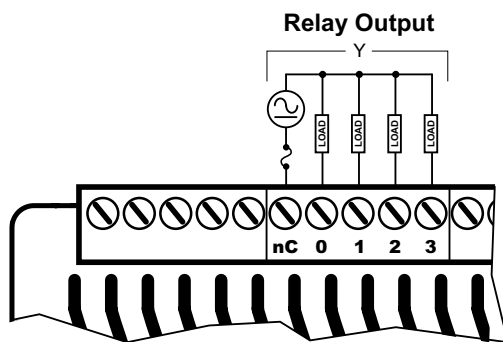

Discrete Standard Output Internal Circuitry

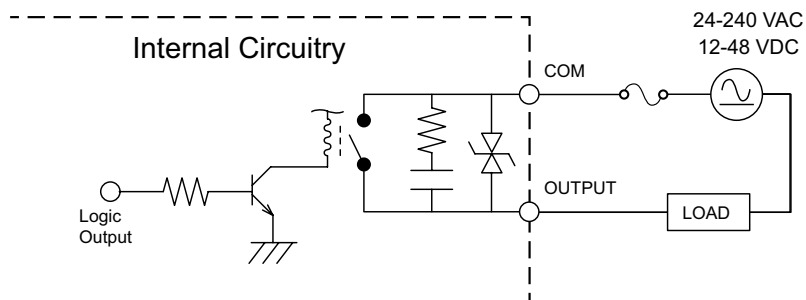

BX-DM1-18ER-D Wiring

This MPU is made up of 18 discrete I/O points. The connections are grouped as follows:

- 10 discrete inputs - sinking/sourcing; rated for 12–24 VAC/VDC. They are located along the bottom of the unit; configured in two (2) groups of 6 terminals, each comprised of 5 inputs and an isolated common.
- 8 discrete outputs - Form A Relay (SPST); rated 12–48 VDC/ 24–240 VAC. They are located along the top of the unit starting to the right of the 24VDC external power supply terminals. The outputs are configured in two (2) groups of 5 terminals, each comprised of 4 outputs and an isolated common.

This MPU requires an external 12–24 VDC power supply. The DC power supply connection is located on the top left side of the unit. There is no 24VDC auxiliary output supply



WARNING: No analog I/O is included on this unit. The 3 terminals to the right of the inputs are not used. These terminals are not internally connected. DO NOT CONNECT ANYTHING TO THESE TERMINALS!



BX-DM1-18ER-D



NOTE: Eight (8) Expansion Modules can be connected to extend I/O capacity, as long as the MPU power budget is not exceeded.

BX-DM1-18ER-D Wiring, Continued

Power Supply Specifications

Power Supply Specifications	
Nominal Voltage Range*	12–24 VDC
Input Voltage Range (Tolerance)*	10–36 VDC
Maximum Input Voltage Ripple	< ±10%
Maximum Input Power	30W
Cold Start Inrush Current	5A, 2ms
Maximum Inrush Current (Hot Start)	5A, 2ms
Internal Input Protection	Reverse polarity protection and undervoltage lockout via transistor circuit
Acceptable External Power Drop Time	10ms
Under Input Voltage Lock-out	<9VDC
Heat Dissipation	17.1 W Max
Isolated User 24VDC Output	None
Voltage Withstand (dielectric)	1500VAC power Inputs to ground applied for 1 minute
Insulation Resistance	>10MΩ @ 500VDC
Software Version Required	Do-more! Designer version 2.0 or later

* Class 2 or LPS Power Supply required.

Power Supply Connections

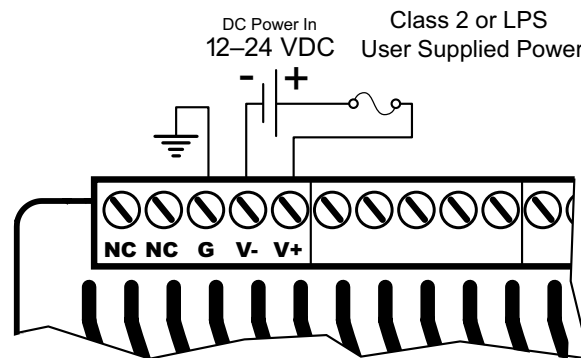

WARNING: No External AC power supply needed on this unit. The two terminals marked "NC" are not used. These terminals are not internally connected. **DO NOT CONNECT ANYTHING TO THESE TERMINALS!**



WARNING: The BRX System **MUST** have a proper earth ground. Do not operate the BRX MPU without proper earth grounding.

BX-DM1-18ER-D Wiring, Continued

Discrete Input Specifications

Discrete Input Specifications		
Input Type	Sink/Source	
Total Inputs per Module	10	
Commons	2 (5 points/common) Isolated	
Nominal Voltage Range	12–24 VAC/VDC	
Input Voltage Range	9–30 VAC/VDC	
Maximum Voltage	30 VAC/VDC	
DC Frequency	0–250 kHz - High-speed	
Minimum Pulse Width	0.5 μ s - High-speed	
AC Frequency	47–63 Hz ²	
Input Impedance	3k Ω @ 24VDC	
Input Current (typical)	6mA @ 24 VAC/VDC	
Maximum Input Current	12mA @ 30 VAC/VDC	
ON Voltage Level	> 9.0 VAC/VDC	
OFF Voltage Level	< 2.0 VAC/VDC	
Maximum OFF Current	1.5 mA	
Status Indicators	Logic Side, Green	
Input Details		
Input Type	High-Speed DC	Standard ¹
Location	X0...X9	
OFF to ON Response	DC	< 2 μ s
	AC	– 10ms ²
ON to OFF Response	DC	< 2 μ s
	AC	– 10ms ²
Maximum Switching Frequency	DC	250kHz
	AC	~ 30Hz

1. All Inputs may be used as standard inputs or high speed inputs independently.
2. 60Hz to 240Hz filter should be set in the software when using an AC line signal.

BX-DM1-18ER-D Wiring, Continued

Discrete Input Connection Options

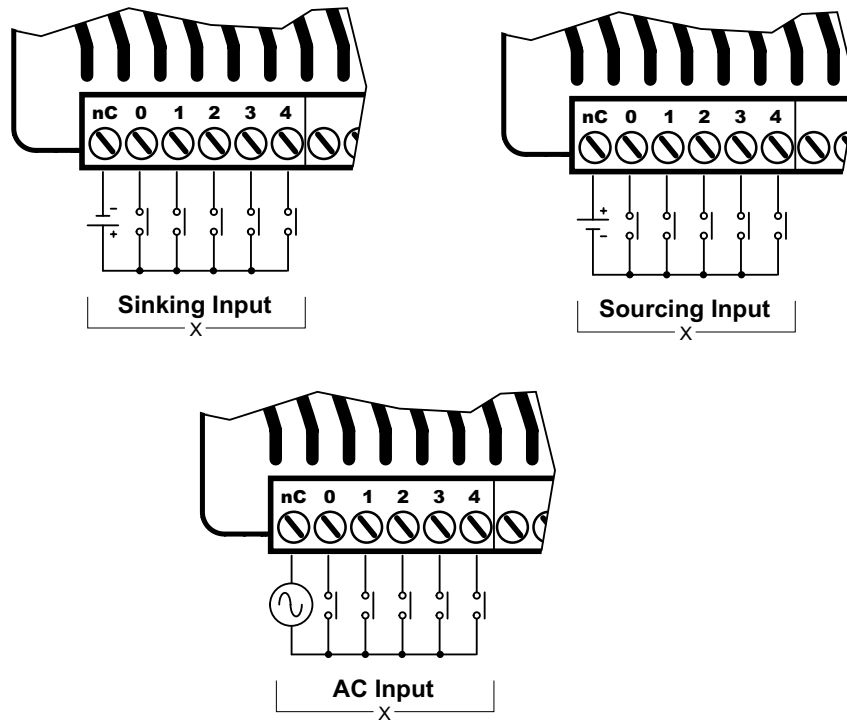

Discrete Input Internal Circuitry *

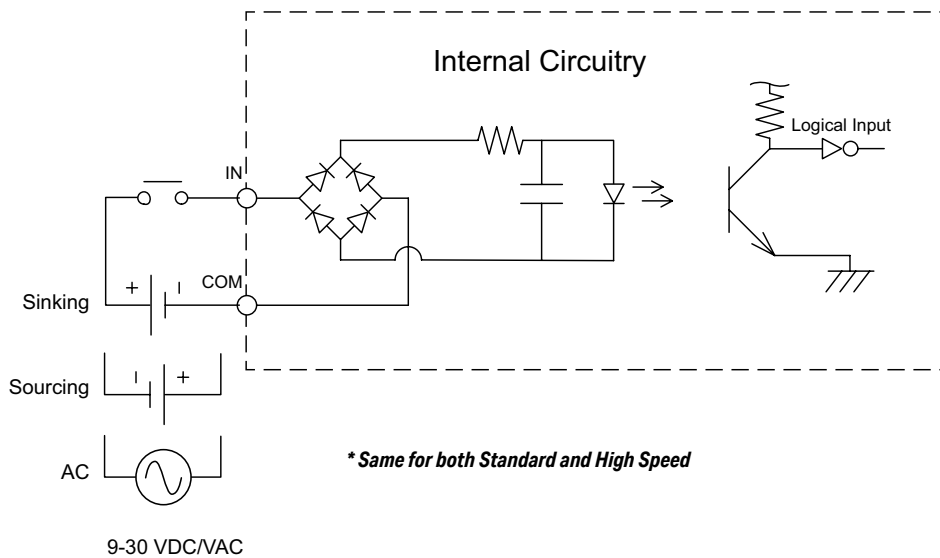

BX-DM1-18ER-D Wiring, Continued

Discrete Output Specifications

Discrete Output Specifications	
Output Type	Relay Form A (SPST)
Total Outputs per Module	8
Commons	2 (4 points/common) Isolated
Maximum Current per Common	8A
Nominal Voltage Range	12–48 VDC 24–240 VAC
Operating Voltage Range	5–60 VDC 5–264 VAC
Maximum Voltage	60VDC 264VAC
Minimum Output Current	0.1 mA @ 24VDC 0.1 mA @ 24VAC
Maximum Output Current	2A
Maximum Inrush Current	5A for 50ms
Maximum Leakage Current	1 μ A (DC), 300 μ A (AC) due to RC snubber circuit
ON Voltage Drop	0.2 V Max
Status Indicators	Logic Side, Green
Output Details	
Output Type	Standard
Location	Y0...Y7
ON-OFF Response	<10ms
OFF-ON Response	<10ms
Maximum Switching Frequency	10Hz
Relay Cycle Life	5 million operations
Mechanical Endurance	120,000 operations
Electrical Endurance	
Fuse Type	User-supplied external fuse

BX-DM1-18ER-D Wiring, Continued

Discrete Output Connection Options

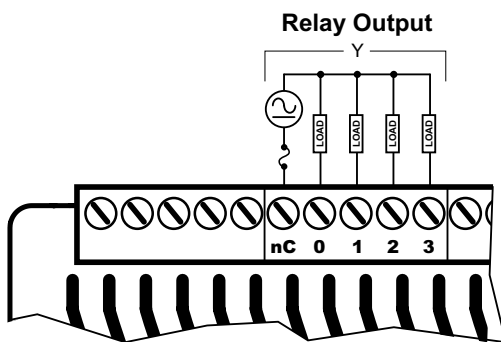

Discrete Standard Output Internal Circuitry

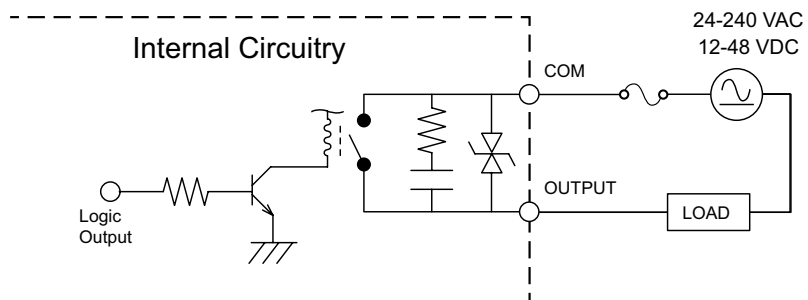

BX-DM1-18AR Wiring

This MPU is made up of 18 discrete I/O points. The connections are grouped as follows:

- 10 discrete inputs - AC rated for 120–240 VAC. They are located along the bottom of the unit; configured in two (2) groups of 6 terminals, each comprised of 5 inputs and an isolated common.
- 8 discrete outputs - Form A Relay (SPST); rated 12–48 VDC/ 24–240 VAC. They are located along the top of the unit starting to the right of the 24VDC auxiliary output terminals. The outputs are configured in two (2) groups of 5 terminals, each comprised of 4 outputs and an isolated common.

This MPU requires an external 120–240 VAC power supply. The AC power supply connection and the 24VDC auxiliary output supply terminals are located on the top left side of the unit.



WARNING: No analog I/O is included on this unit. The 3 terminals to the right of the inputs are not used. These terminals are not internally connected. **DO NOT CONNECT ANYTHING TO THESE TERMINALS!**



BX-DM1-18AR



NOTE: Eight (8) Expansion Modules can be connected to extend I/O capacity, as long as the MPU power budget is not exceeded.

BX-DM1-18AR Wiring, Continued

Power Supply Specifications

Power Supply Specifications	
Nominal Voltage Range	120–240 VAC
Input Voltage Range (Tolerance)	85–264 VAC
Rated Operating Frequency	47–63 Hz
Maximum Input Power	40VA
Cold Start Inrush Current	1.5 A, 2ms
Maximum Inrush Current (Hot Start)	1.5 A, 2ms
Internal Input Fuse Protection	Micro fuse 250V, 2A Non-replaceable
Acceptable External Power Drop Time	10ms
Under Input Voltage Lock-out	80VAC
Input Transient Protection	Input choke and line filter
Heat Dissipation	18.9 W Max
Isolated User 24VDC Output	24VDC @ 0.3 A max, <1V P-P Ripple, Integrated self-resetting short circuit protection
Voltage Withstand (dielectric)	1500VAC Power Inputs to Ground applied for 1 minute 1500VAC Ground to 24VDC Output applied for 1 minute
Insulation Resistance	>10M Ω @ 500VDC
Software Version Required	Do-more! Designer version 2.0 or later

Power Supply Connections

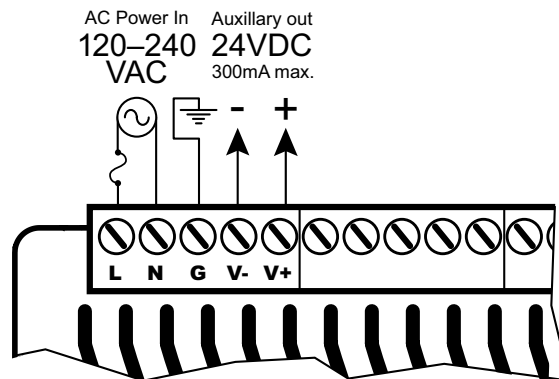

WARNING: Do not exceed the 24VDC auxiliary power supply load limit of 300mA.



WARNING: The BRX System **MUST** have a proper earth ground. Do not operate the BRX MPU without proper earth grounding.

BX-DM1-18AR Wiring, Continued

Discrete Input Specifications

Discrete Input Specifications	
Input Type	AC
Total Inputs per Module	10
Commons	2 (5 points/common) Isolated
Nominal Voltage Range	120–240 VAC
Input Voltage Range	85–264 VAC
Maximum Voltage	264VAC RMS
AC Frequency	47–63 Hz
Input Impedance	15k Ω
Input Current (typical)	9mA @ 120VAC, 13mA @ 220VAC
Maximum Input Current	14mA @ 120VAC, 20mA @ 220VAC
ON Voltage Level	> 85VAC
OFF Voltage Level	< 40VAC
Maximum OFF Current	2.5 mA
Status Indicators	Logic Side, Green
Input Details	
Input Type	Standard
Location	X0...X9
OFF - ON Response	10ms
ON - OFF Response	10ms
Maximum Switching Frequency	~ 30Hz

Discrete Input Connection Options

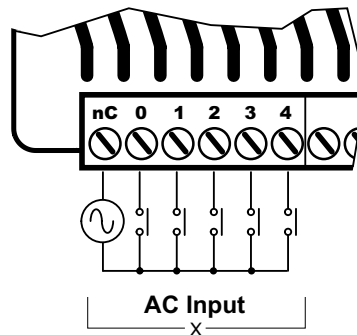

Discrete Input Internal Circuitry

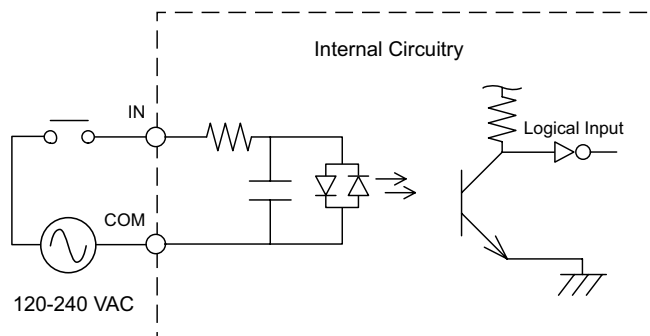

BX-DM1-18AR Wiring, Continued

Discrete Output Specifications

Discrete Output Specifications	
Output Type	Relay Form A (SPST)
Total Outputs per Module	8
Commons	2 (4 points/common) Isolated
Maximum Current per Common	8A
Nominal Voltage Range	12–48 VDC 24–240 VAC
Operating Voltage Range	5–60 VDC 5–264 VAC
Maximum Voltage	60VDC 264VAC
Minimum Output Current	0.1 mA @ 24VDC 0.1 mA @ 24VAC
Maximum Output Current	2A
Maximum Inrush Current	5A for 50ms
Maximum Leakage Current	1 μ A (DC), 300 μ A (AC) due to RC snubber circuit
ON Voltage Drop	0.2 V Max
Status Indicators	Logic Side, Green
Output Details	
Output Type	Standard
Location	Y0...Y7
ON-OFF Response	<10ms
OFF-ON Response	<10ms
Maximum Switching Frequency	10Hz
Relay Cycle Life	5 million operations
Mechanical Endurance	120,000 operations
Electrical Endurance	
Fuse Type	User-supplied external fuse

BX-DM1-18AR Wiring, Continued

Discrete Output Connection Options

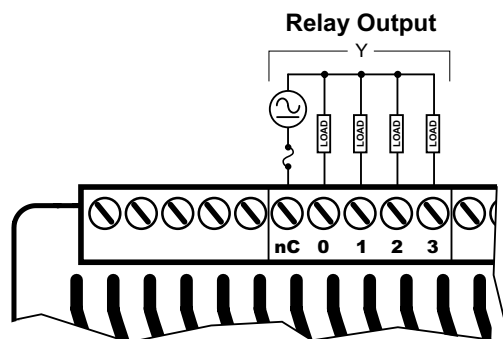

Discrete Standard Output Internal Circuitry

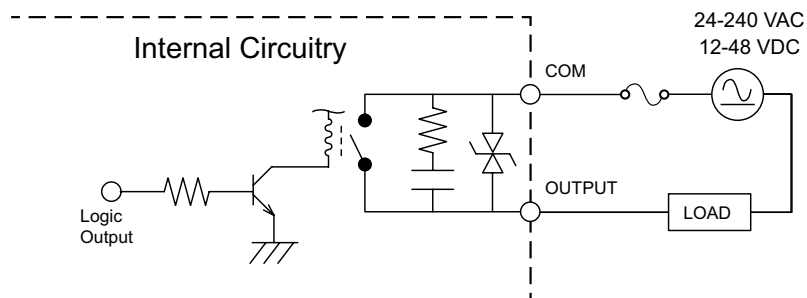

BX 18E Micro PLC Units (MPUs)

BX-DM1E-18ED13 Wiring

This MPU is made up of 18 discrete I/O points. The connections are grouped as follows:

- 10 discrete inputs - sinking/sourcing; rated for 12–24 VAC/VDC. They are located along the bottom of the unit; configured in two (2) groups of 6 terminals, each comprised of 5 inputs and an isolated common.
- 8 discrete outputs - sinking; rated at 12–24 VDC. They are located along the top of the unit starting to the right of the 24VDC auxiliary output terminals. The outputs are configured in two (2) groups of 5 terminals, each comprised of 4 outputs and an isolated common.
- 1 analog input and 1 analog output. They are located along the bottom of the unit to the right of the discrete inputs. The analogs are a group of three (3) terminals, comprised of 1 input, 1 output and a shared isolated common. The analogs share these common features:
 - current or voltage selectable through software
 - 16-bit resolution @ $\pm 20\text{mA}$, $\pm 10\text{VDC}$
 - current signal ranges of 4–20 mA, $\pm 20\text{mA}$
 - voltage signal ranges of 0–5 VDC, 0–10 VDC, $\pm 5\text{VDC}$, $\pm 10\text{VDC}$.

This MPU requires an external 120–240 VAC power supply. The AC power supply connection and the 24VDC auxiliary output supply terminals are located on the top left side of the unit.

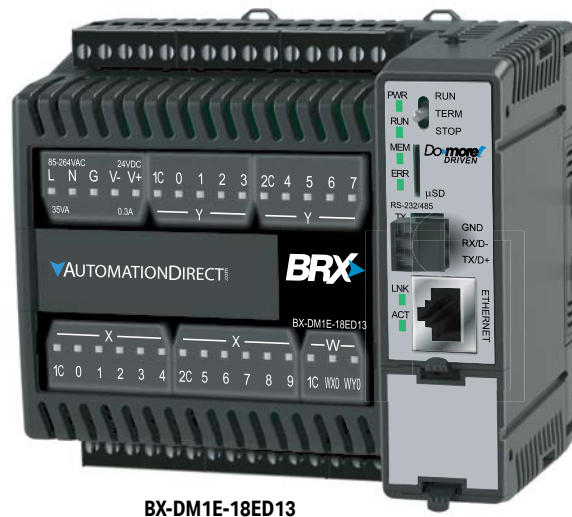

BX-DM1E-18ED13



NOTE: Eight (8) Expansion Modules can be connected to extend I/O capacity.

BX-DM1E-18ED13 Wiring, Continued

Power Supply Specifications

Power Supply Specifications	
Nominal Voltage Range	120–240 VAC
Input Voltage Range (Tolerance)	85–264 VAC
Rated Operating Frequency	47–63 Hz
Maximum Input Power	40VA
Cold Start Inrush Current	1.5 A, 2ms
Maximum Inrush Current (Hot Start)	1.5 A, 2ms
Internal Input Fuse Protection	Micro fuse 250V, 2A Non-replaceable
Acceptable External Power Drop Time	10ms
Under Input Voltage Lock-out	80VAC
Input Transient Protection	Input choke and line filter
Heat Dissipation	17.6 W Max
Isolated User 24VDC Output	24VDC @ 0.3 A max, <1V P-P Ripple, Integrated self-resetting short circuit protection
Voltage Withstand (dielectric)	1500VAC Power Inputs to Ground applied for 1 minute 1500VAC Ground to 24VDC Output applied for 1 minute
Insulation Resistance	>10M Ω @ 500VDC
Software Version Required	Do-more! Designer version 2.0 or later

Power Supply Connections

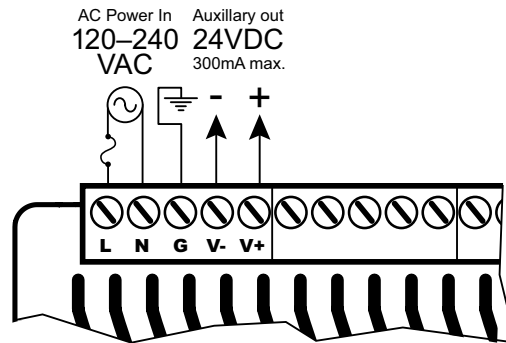

WARNING: Do not exceed the 24VDC auxiliary power supply load limit of 300mA.



WARNING: The BRX System **MUST** have a proper earth ground. Do not operate the BRX MPU without proper earth grounding.

BX-DM1E-18ED13 Wiring, Continued

Discrete Input Specifications

Discrete Input Specifications		
Input Type	Sink/Source	
Total Inputs per Module	10	
Commons	2 (5 points/common) Isolated	
Nominal Voltage Range	12–24 VAC/VDC	
Input Voltage Range	9–30 VAC/VDC	
Maximum Voltage	30 VAC/VDC	
DC Frequency	0–250 kHz - High-speed	
Minimum Pulse Width	0.5 μ s - High-speed	
AC Frequency	47–63 Hz ²	
Input Impedance	3k Ω @ 24VDC	
Input Current (typical)	6mA @ 24 VAC/VDC	
Maximum Input Current	12mA @ 30 VAC/VDC	
ON Voltage Level	> 9.0 VAC/VDC	
OFF Voltage Level	< 2.0 VAC/VDC	
Maximum OFF Current	1.5 mA	
Status Indicators	Logic Side, Green	
Input Details		
Input Type	High-Speed DC	Standard ¹
Location	X0...X9	
OFF to ON Response	DC	< 2 μ s
	AC	–
ON to OFF Response	DC	< 2 μ s
	AC	–
Maximum Switching Frequency	DC	250kHz
	AC	~ 30Hz

- 1. All Inputs may be used as standard inputs or high speed inputs independently.*
- 2. 60Hz to 240Hz filter should be set in the software when using an AC line signal.*

BX-DM1E-18ED13 Wiring, Continued

Discrete Input Connection Options

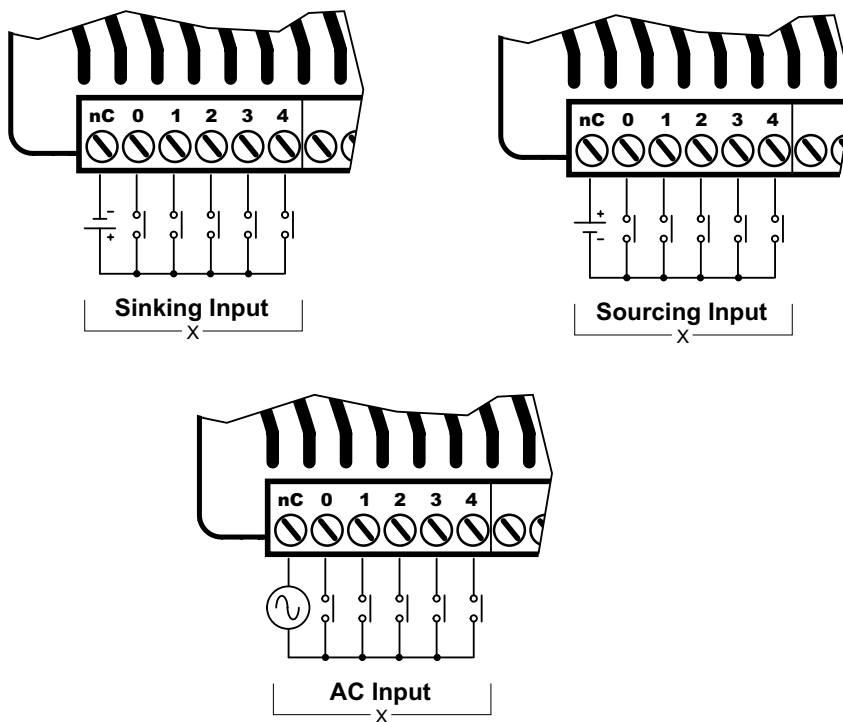

Discrete Input Internal Circuitry *

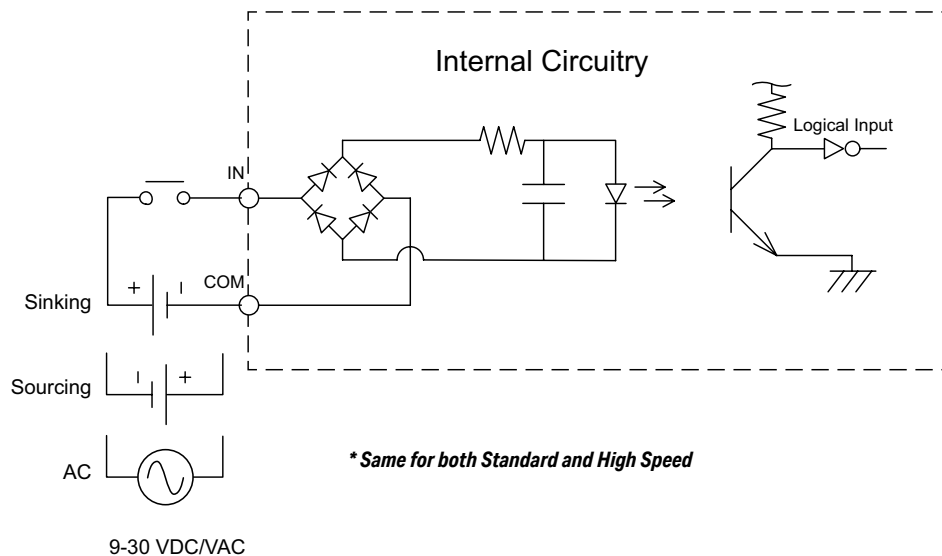

BX-DM1E-18ED13 Wiring, Continued

Discrete Output Specifications

Discrete Output Specifications		
Output Type	Sinking	
Total Outputs per Module	8	
Commons	2 (4 points/common) Isolated	
Maximum Current per Common	2A	
Nominal Voltage Range	12–24 VDC	
Operating Voltage Range	5–36 VDC	
Maximum Voltage	36VDC	
Minimum Output Current	0.1 mA @ 24VDC	
Maximum Output Current	0.5 A per output No derating over temperature range	
Maximum Inrush Current	5A for 50ms	
Maximum Leakage Current	10 μ A	
ON Voltage Drop	0.05 VDC	
Status Indicators	Logic Side, Green	
Output Details		
Output Type	High-Speed	Standard ¹
Location	Y0...Y3	Y4...Y7
OFF to ON Response	< 2 μ s	< 5ms
ON to OFF Response	< 2 μ s	< 2ms
Maximum Switching Frequency	1m cable - 250kHz 10m cable - 100kHz	~ 100Hz
Overcurrent, Short Circuit Protection and Short to Ground	Current limit by Common Group, self-resetting	N/A
Overcurrent Trip Level ²	Between 4A and 8A	N/A
Fuse Type	User-supplied external fuse	

- 1. All outputs may be used as standard outputs. Only the first 4 outputs (Y0...Y3) are capable of high-speed DC operation.*
- 2. When the high-speed outputs are in an overcurrent situation, the Common terminal Red LED is on. The output LEDs will remain operational even though the output circuitry is turned off and no power is flowing. This condition is not reported to the CPU.*

BX-DM1E-18ED13 Wiring, continued

Discrete Output Connection Options

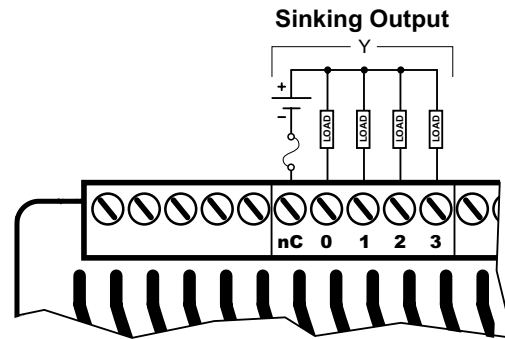

Discrete Standard Output Internal Circuitry

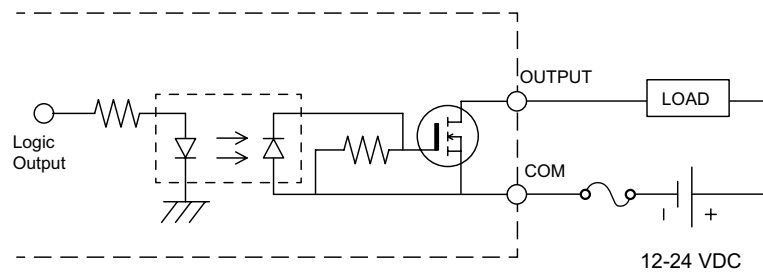

Discrete High-Speed Output Internal Circuitry

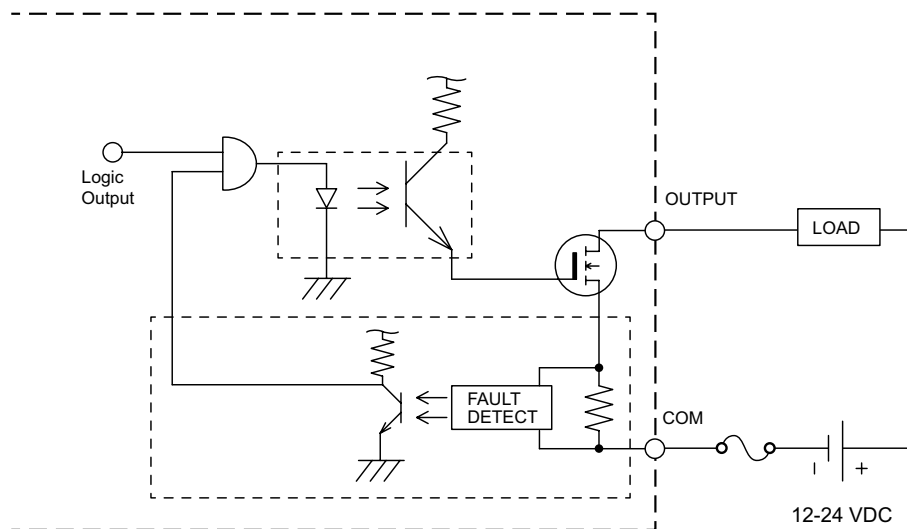

NOTE: When the high speed outputs are in an overcurrent situation, the Common terminal Red LED is on. The output LEDs will remain operational even though the output circuitry is turned off and no power is flowing. This condition is not reported to the CPU.

BX-DM1E-18ED13 Wiring, Continued

Analog Input Specifications

Analog Input Specifications	
Inputs per Module	1
Commons	1
Input Voltage Range *	Software Selectable $\pm 10V$, $\pm 5V$, 0–10 V, 0–5 V
Input Current Range *	Software Selectable $\pm 20mA$, 4–20 mA
Resolution $\pm 10V$, $\pm 20mA$ $\pm 5V$ 0–5 V 4–20 mA 0–10 V	16 bits (0–65535 counts) 15 bits (0–32767 counts) 14 bits (0–16383 counts) ~15 bits (6553–32767 counts) 15 bits (0–32767 counts)
Input Impedance Voltage Modes	100k Ω
Absolute Maximum Input, Voltage Mode	$\pm 30V$
Input Impedance Current Modes	249 Ω
Absolute Maximum Input, Current Mode	$\pm 40mA$ sustained, $\pm 100mA$ for < 5s
Conversion Time	1.2 ms
Input Stability	0.02% of Full Hardware Range = 13 Counts
Full Scale Calibration Error	0.05% of Full Hardware Range = 33 Counts
Offset Calibration Error	0.01% of Full Hardware Range = 7 Counts
Accuracy vs Temperature Error	0.05% of Full Hardware Range = 33 Counts
Maximum Linearity Error (End to End)	0.1% of Full Hardware Range = 66 Counts
Maximum Inaccuracy	0.2% of Full Hardware Range = 131 Counts
Fuse Type	User-supplied external fuse

* Software selectable per channel

BX-DM1E-18ED13 Wiring, Continued

Analog Input Connection Options

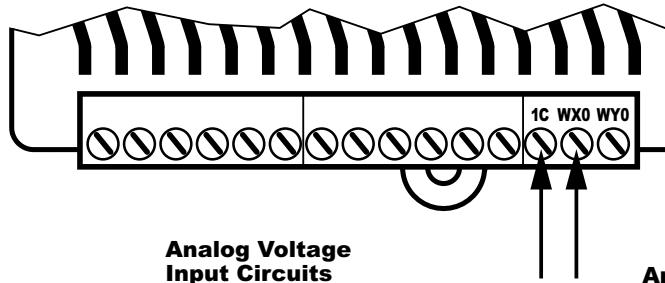

Analog Voltage Input Circuits

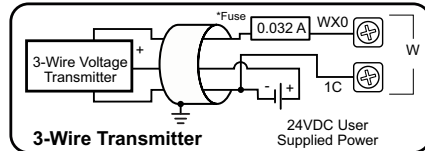
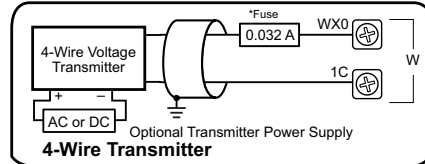

NOTE: Shield should be connected only at one end, to ground at the source device.

Analog Current Sinking Input Circuits

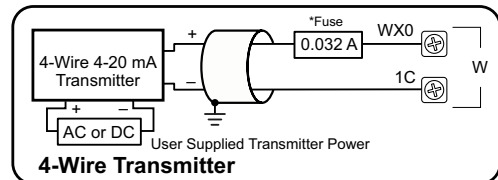
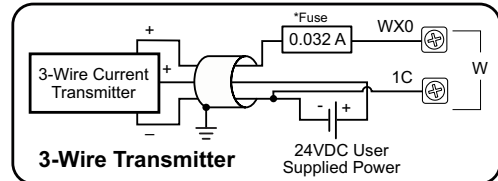
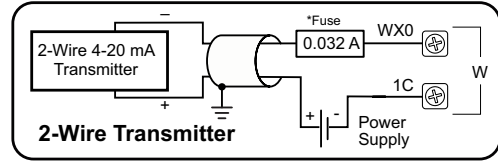

NOTE: Shield should be connected only at one end, to ground at the source device.



NOTE: An Edison S500-32-R 0.032A fast-acting fuse is recommended for all analog voltage inputs, analog outputs, and current loops.

BX-DM1E-18ED13 Wiring, Continued

Analog Output Specifications

Analog Output Specifications	
Outputs per Module	1
Commons	1
Output Voltage Range *	Software Selectable $\pm 10V$, $\pm 5V$, 0–10 V, 0–5 V
Output Current Range *	Software Selectable $\pm 20mA$, 4–20 mA
Resolution $\pm 10V$, $\pm 20mA$ $\pm 5V$ 0–5 V 4–20 mA 0–10 V	16 bits (0–65535 counts) 15 bits (0–32767 counts) 14 bits (0–16383 counts) ~15 bits (6553–32767 counts) 15 bits (0–32767 counts)
Minimum Voltage Load Impedance	1k Ω
Maximum Current Load Impedance	500 Ω
Maximum Rating	Continuous Short Circuit Protected
Settling Time	< 1ms
Output Stability	0.02% of Full Hardware Range = 13 Counts
Full Scale Calibration Error	0.05% of Full Hardware Range = 33 Counts
Offset Calibration Error	0.01% of Full Hardware Range = 7 Counts
Accuracy vs Temperature Error	0.05% of Full Hardware Range = 33 Counts
Maximum Linearity Error (End to End)	0.1% of Full Hardware Range = 66 Counts
Maximum Inaccuracy	0.2% of Full Hardware Range = 131 Counts
Fuse Type	User-supplied external fuse

* Software selectable per channel

Analog Output Connection Options

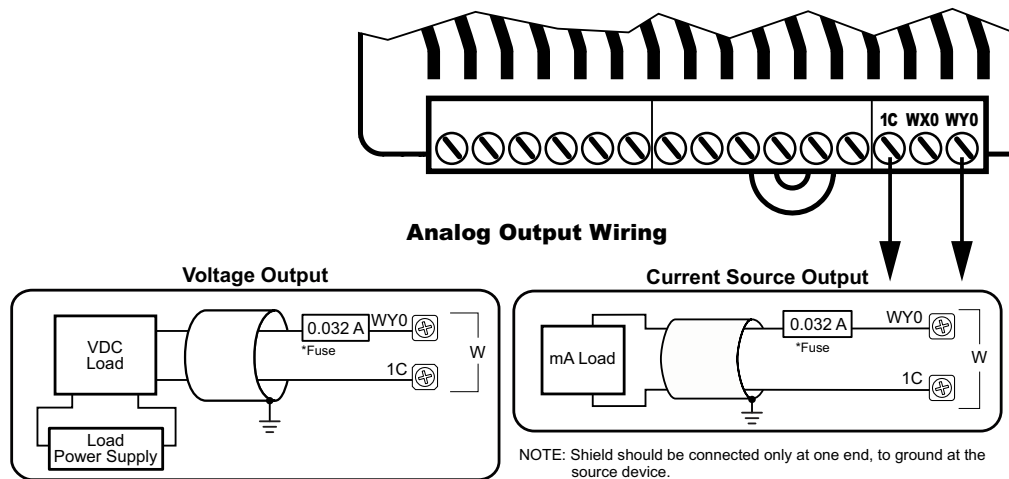

NOTE: An Edison S500-32-R 0.032A fast-acting fuse is recommended for all analog voltage inputs, analog outputs, and current loops.

BX-DM1E-18ED13-D Wiring

This MPU is made up of 18 discrete I/O points. The connections are grouped as follows:

- 10 discrete inputs - sinking/sourcing; rated for 12–24 VAC/VDC. They are located along the bottom of the unit; configured in two (2) groups of six (6) terminals, each comprised of five (5) inputs and an isolated common.
- 8 discrete outputs - sinking; rated at 12–24 VDC. They are located along the top of the unit starting to the right of the 24VDC external power supply terminals. The outputs are configured in two (2) groups of five (5) terminals, each comprised of four (4) outputs and an isolated common.
- 1 analog input and 1 analog output. They are located along the bottom of the unit to the right of the discrete inputs. The analogs are a group of three (3) terminals, comprised of 1 input, 1 output and a shared isolated common. The analogs share these common features:
 - current or voltage selectable through software,
 - 16-bit resolution @ ± 20 mA, ± 10 VDC
 - current signal ranges of 4–20 mA, ± 20 mA,
 - voltage signal ranges of 0–5 VDC, 0–10 VDC, ± 5 VDC, ± 10 VDC.

This MPU requires an external 12–24 VDC power supply. The DC power supply connection is located on the top left side of the unit. There is no 24VDC auxiliary output supply.



BX-DM1E-18ED13-D



NOTE: Eight (8) Expansion Modules can be connected to extend I/O capacity.

BX-DM1E-18ED13-D Wiring, Continued

Power Supply Specifications

Power Supply Specifications	
Nominal Voltage Range*	12–24 VDC
Input Voltage Range (Tolerance)*	10–36 VDC
Maximum Input Voltage Ripple	< ±10%
Maximum Input Power	30W
Cold Start Inrush Current	5A, 2ms
Maximum Inrush Current (Hot Start)	5A, 2ms
Internal Input Protection	Reverse polarity protection and undervoltage lockout via transistor circuit
Acceptable External Power Drop Time	10ms
Under Input Voltage Lock-out	<9VDC
Heat Dissipation	15.4 W Max
Isolated User 24VDC Output	None
Voltage Withstand (dielectric)	1500VAC power Inputs to ground applied for 1 minute
Insulation Resistance	>10MΩ @ 500VDC
Software Version Required	Do-more! Designer version 2.0 or later

* Class 2 or LPS Power Supply required.

Power Supply Connections

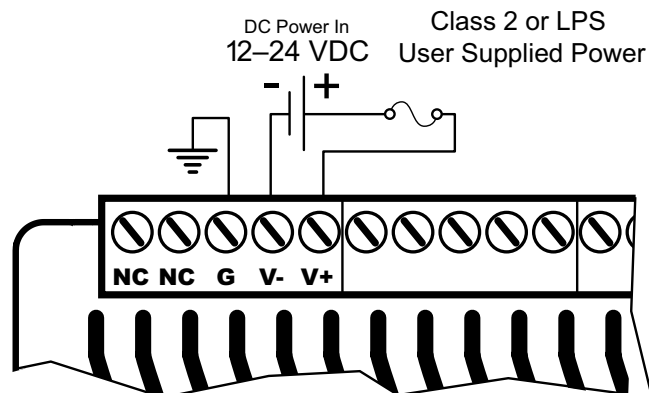

WARNING: No External AC power supply needed on this unit. The two terminals marked "NC" are not used. These terminals are not internally connected. **DO NOT CONNECT ANYTHING TO THESE TERMINALS!**



WARNING: The BRX System **MUST** have a proper earth ground. Do not operate the BRX MPU without proper earth grounding.

BX-DM1E-18ED13-D Wiring, Continued

Discrete Input Specifications

Discrete Input Specifications		
Input Type	Sink/Source	
Total Inputs per Module	10	
Commons	2 (5 points/common) Isolated	
Nominal Voltage Range	12–24 VAC/VDC	
Input Voltage Range	9–30 VAC/VDC	
Maximum Voltage	30 VAC/VDC	
DC Frequency	0–250 kHz - High-speed	
Minimum Pulse Width	0.5 μ s - High-speed	
AC Frequency	47–63 Hz ²	
Input Impedance	3k Ω @ 24VDC	
Input Current (typical)	6mA @ 24 VAC/VDC	
Maximum Input Current	12mA @ 30 VAC/VDC	
ON Voltage Level	> 9.0 VAC/VDC	
OFF Voltage Level	< 2.0 VAC/VDC	
Maximum OFF Current	1.5 mA	
Status Indicators	Logic Side, Green	
Input Details		
Input Type	High-Speed DC	Standard ¹
Location	X0...X9	
OFF to ON Response	DC	< 2 μ s
	AC	– 10ms ²
ON to OFF Response	DC	< 2 μ s
	AC	– 10ms ²
Maximum Switching Frequency	DC	250kHz
	AC	~ 30Hz

- 1. All Inputs may be used as standard inputs or high speed inputs independently.*
- 2. 60Hz to 240Hz filter should be set in the software when using an AC line signal.*

BX-DM1E-18ED13-D Wiring, Continued

Discrete Input Connection Options

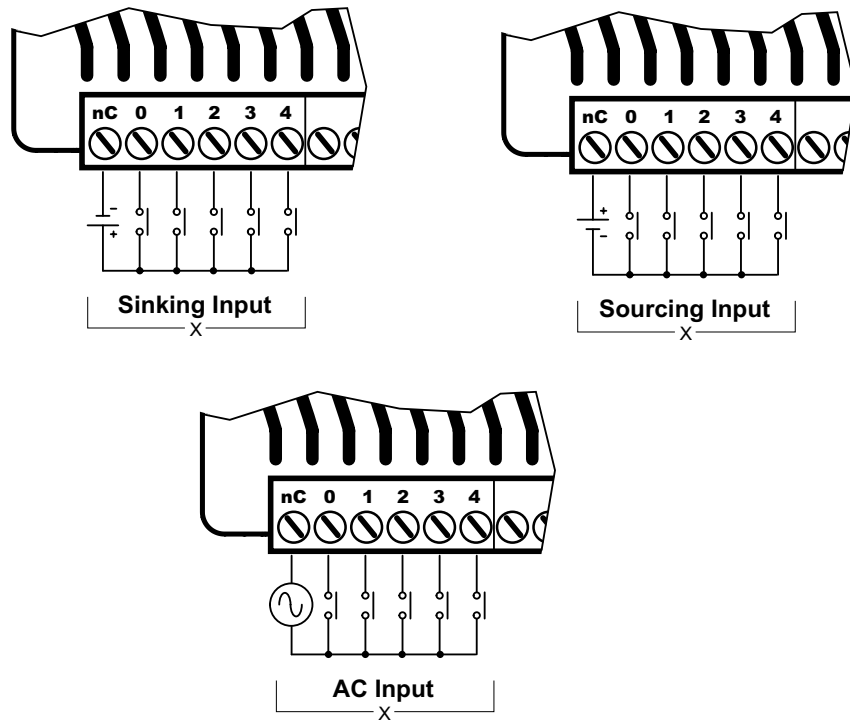

Discrete Input Internal Circuitry *

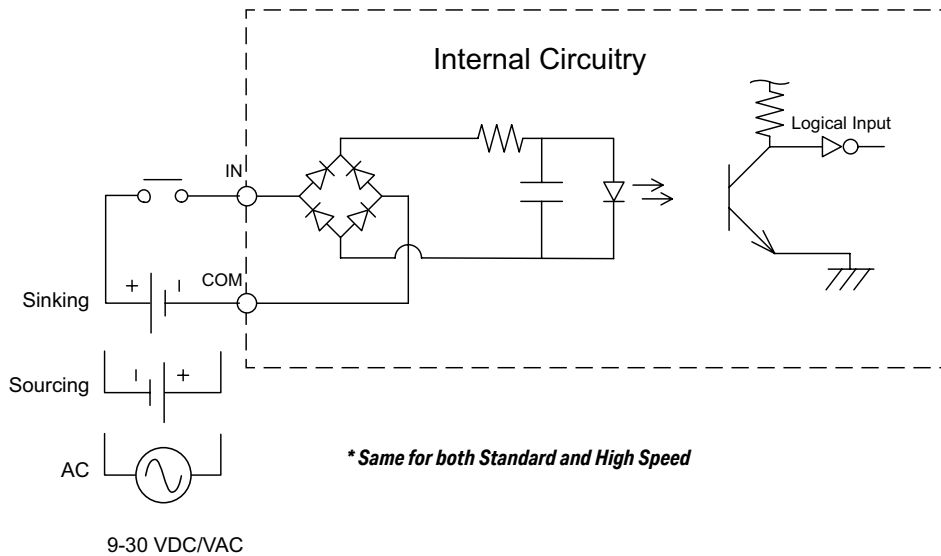

BX-DM1E-18ED13-D Wiring, Continued

Discrete Output Specifications

Discrete Output Specifications		
Output Type	Sinking	
Total Outputs per Module	8	
Commons	2 (4 points/common) Isolated	
Maximum Current per Common	2A	
Nominal Voltage Range	12–24 VDC	
Operating Voltage Range	5–36 VDC	
Maximum Voltage	36VDC	
Minimum Output Current	0.1 mA @ 24VDC	
Maximum Output Current	0.5 A per output No derating over temperature range	
Maximum Inrush Current	5A for 50ms	
Maximum Leakage Current	10 μ A	
ON Voltage Drop	0.05 VDC	
Status Indicators	Logic Side, Green	
Output Details		
Output Type	High-Speed	Standard ¹
Location	Y0...Y3	Y4...Y7
OFF to ON Response	< 2 μ s	< 5ms
ON to OFF Response	< 2 μ s	< 2ms
Maximum Switching Frequency	1m cable - 250kHz 10m cable - 100kHz	~ 100Hz
Overcurrent, Short Circuit Protection and Short to Ground	Current limit by Common Group, self-resetting	N/A
Overcurrent Trip Level ²	Between 4A and 8A	N/A
Fuse Type	User-supplied external fuse	

- All outputs may be used as standard outputs. Only the first 4 outputs (Y0...Y3) are capable of high-speed DC operation.***
- When the high-speed outputs are in an overcurrent situation, the Common terminal Red LED is on. The output LEDs will remain operational even though the output circuitry is turned off and no power is flowing. This condition is not reported to the CPU.***

BX-DM1E-18ED13-D Wiring, Continued

Discrete Output Connection Options

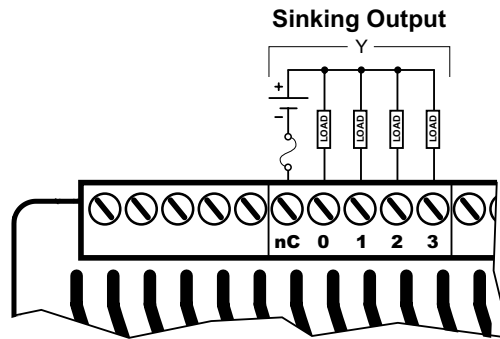

Discrete Standard Output Internal Circuitry

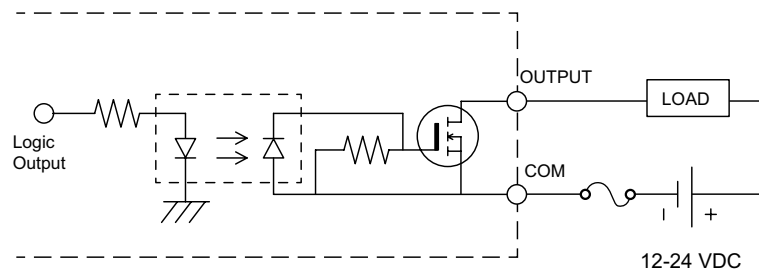

Discrete High-Speed Output Internal Circuitry

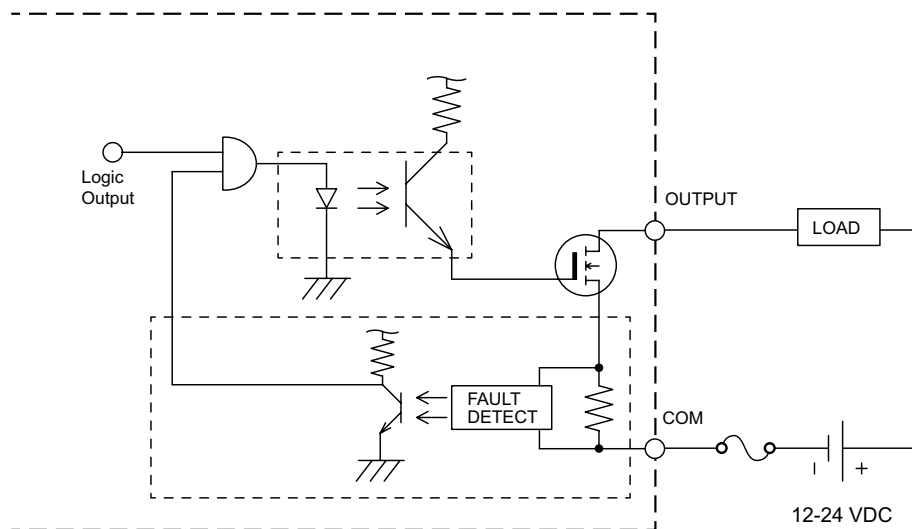

NOTE: When the high speed outputs are in an overcurrent situation, the Common terminal Red LED is on. The output LEDs will remain operational even though the output circuitry is turned off and no power is flowing. This condition is not reported to the CPU.

BX-DM1E-18ED13-D Wiring, Continued

Analog Input Specifications

Analog Input Specifications	
Inputs per Module	1
Commons	1
Input Voltage Range *	Software Selectable $\pm 10V$, $\pm 5V$, 0–10 V, 0–5 V
Input Current Range *	Software Selectable $\pm 20mA$, 4–20 mA
Resolution $\pm 10V$, $\pm 20mA$ $\pm 5V$ 0–5 V 4–20 mA 0–10 V	16 bits (0–65535 counts) 15 bits (0–32767 counts) 14 bits (0–16383 counts) ~15 bits (6553–32767 counts) 15 bits (0–32767 counts)
Input Impedance Voltage Modes	100k Ω
Absolute Maximum Input, Voltage Mode	$\pm 30V$
Input Impedance Current Modes	249 Ω
Absolute Maximum Input, Current Mode	$\pm 40mA$ sustained, $\pm 100mA$ for < 5s
Conversion Time	1.2 ms
Input Stability	0.02% of Full Hardware Range = 13 Counts
Full Scale Calibration Error	0.05% of Full Hardware Range = 33 Counts
Offset Calibration Error	0.01% of Full Hardware Range = 7 Counts
Accuracy vs Temperature Error	0.05% of Full Hardware Range = 33 Counts
Maximum Linearity Error (End to End)	0.1% of Full Hardware Range = 66 Counts
Maximum Inaccuracy	0.2% of Full Hardware Range = 131 Counts
Fuse Type	User-supplied external fuse

* *Software selectable per channel*

BX-DM1E-18ED13-D Wiring, Continued

Analog Input Connection Options

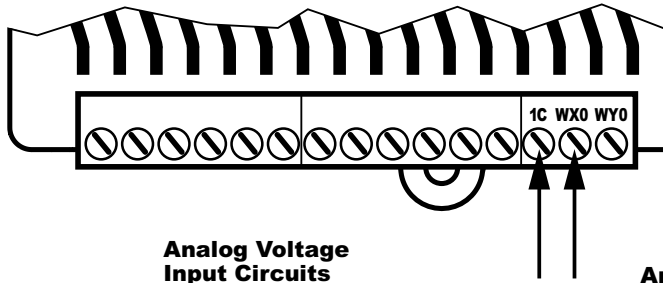

Analog Voltage Input Circuits

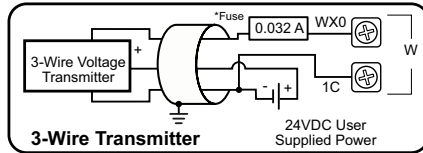
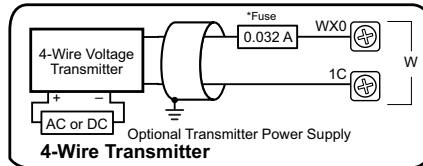

NOTE: Shield should be connected only at one end, to ground at the source device.

Analog Current Sinking Input Circuits

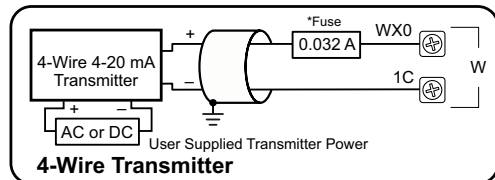
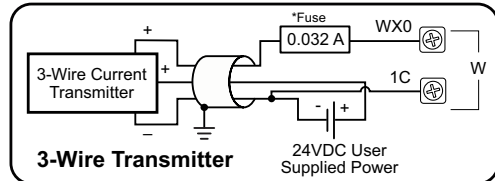
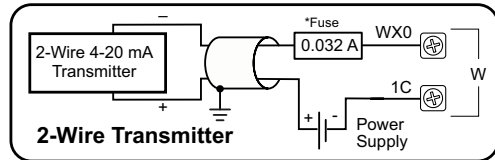

NOTE: Shield should be connected only at one end, to ground at the source device.



NOTE: An Edison S500-32-R 0.032A fast-acting fuse is recommended for all analog voltage inputs, analog outputs, and current loops.

BX-DM1E-18ED13-D Wiring, Continued

Analog Output Specifications

Analog Output Specifications	
Outputs per Module	1
Commons	1
Output Voltage Range *	Software Selectable $\pm 10V$, $\pm 5V$, 0–10 V, 0–5 V
Output Current Range *	Software Selectable $\pm 20mA$, 4–20 mA
Resolution $\pm 10V$, $\pm 20mA$ $\pm 5V$ 0–5 V 4–20 mA 0–10 V	16 bits (0–65535 counts) 15 bits (0–32767 counts) 14 bits (0–16383 counts) ~15 bits (6553–32767 counts) 15 bits (0–32767 counts)
Minimum Voltage Load Impedance	1k Ω
Maximum Current Load Impedance	500 Ω
Maximum Rating	Continuous Short Circuit Protected
Settling Time	< 1ms
Output Stability	0.02% of Full Hardware Range = 13 Counts
Full Scale Calibration Error	0.05% of Full Hardware Range = 33 Counts
Offset Calibration Error	0.01% of Full Hardware Range = 7 Counts
Accuracy vs Temperature Error	0.05% of Full Hardware Range = 33 Counts
Maximum Linearity Error (End to End)	0.1% of Full Hardware Range = 66 Counts
Maximum Inaccuracy	0.2% of Full Hardware Range = 131 Counts
Fuse Type	User-supplied external fuse

* Software selectable per channel

Analog Output Connection Options

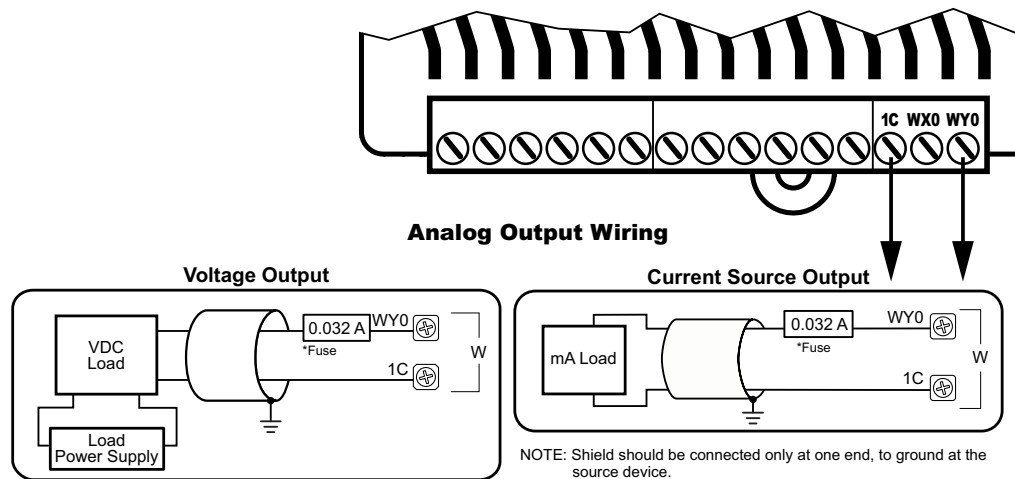

NOTE: An Edison S500-32-R 0.032A fast-acting fuse is recommended for all analog voltage inputs, analog outputs, and current loops.

BX-DM1E-18ED23 Wiring

This MPU is made up of 18 discrete I/O points. The connections are grouped as follows:

- 10 discrete inputs - sinking/sourcing; rated for 12–24 VAC/VDC. They are located along the bottom of the unit; configured in two (2) groups of 6 terminals, each comprised of 5 inputs and an isolated common.
- 8 discrete outputs - sourcing; rated at 12–24 VDC. They are located along the top of the unit starting to the right of the 24VDC auxiliary output terminals. The outputs are configured in two (2) groups of 5 terminals, each comprised of 4 outputs and an isolated common.
- 1 analog input and 1 analog output. They are located along the bottom of the unit to the right of the discrete inputs. The analogs are a group of three (3) terminals, comprised of 1 input, 1 output and a shared isolated common. The analogs share these common features:
 - current or voltage selectable through software,
 - 16-bit resolution @ $\pm 20\text{mA}$, $\pm 10\text{VDC}$
 - current signal ranges of 4–20 mA, $\pm 20\text{mA}$,
 - voltage signal ranges of 0–5 VDC, 0–10 VDC, $\pm 5\text{VDC}$, $\pm 10\text{VDC}$.

This MPU requires an external 120–240 VAC power supply. The AC power supply connection and the 24VDC auxiliary output supply terminals are located on the top left side of the unit.



BX-DM1E-18ED23



NOTE: Eight (8) Expansion Modules can be connected to extend I/O capacity.

BX-DM1E-18ED23 Wiring, Continued

Power Supply Specifications

Power Supply Specifications	
Nominal Voltage Range	120–240 VAC
Input Voltage Range (Tolerance)	85–264 VAC
Rated Operating Frequency	47–63 Hz
Maximum Input Power	40VA
Cold Start Inrush Current	1.5 A, 2ms
Maximum Inrush Current (Hot Start)	1.5 A, 2ms
Internal Input Fuse Protection	Micro fuse 250V, 2A Non-replaceable
Acceptable External Power Drop Time	10ms
Under Input Voltage Lock-out	80VAC
Input Transient Protection	Input choke and line filter
Heat Dissipation	17.6 W Max
Isolated User 24VDC Output	24VDC @ 0.3 A max, <1V P-P Ripple, Integrated self-resetting short circuit protection
Voltage Withstand (dielectric)	1500VAC Power Inputs to Ground applied for 1 minute 1500VAC Ground to 24VDC Output applied for 1 minute
Insulation Resistance	>10M Ω @ 500VDC
Software Version Required	Do-more! Designer version 2.0 or later

Power Supply Connections

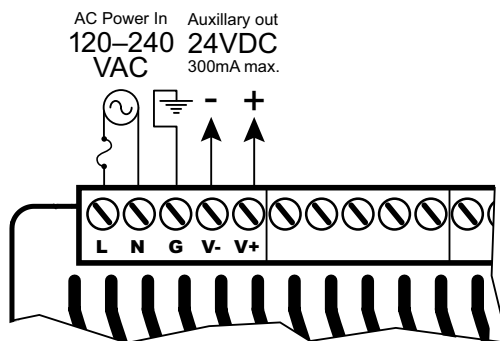

WARNING: Do not exceed the 24VDC auxiliary power supply load limit of 300mA.



WARNING: The BRX System **MUST** have a proper earth ground. Do not operate the BRX MPU without proper earth grounding.

BX-DM1E-18ED23 Wiring, Continued

Discrete Input Specifications

Discrete Input Specifications		
Input Type	Sink/Source	
Total Inputs per Module	10	
Commons	2 (5 points/common) Isolated	
Nominal Voltage Range	12–24 VAC/VDC	
Input Voltage Range	9–30 VAC/VDC	
Maximum Voltage	30 VAC/VDC	
DC Frequency	0–250 kHz - High-speed	
Minimum Pulse Width	0.5 μ s - High-speed	
AC Frequency	47–63 Hz ²	
Input Impedance	3k Ω @ 24VDC	
Input Current (typical)	6mA @ 24 VAC/VDC	
Maximum Input Current	12mA @ 30 VAC/VDC	
ON Voltage Level	> 9.0 VAC/VDC	
OFF Voltage Level	< 2.0 VAC/VDC	
Maximum OFF Current	1.5 mA	
Status Indicators	Logic Side, Green	
Input Details		
Input Type	High-Speed DC	Standard ¹
Location	X0...X9	
OFF to ON Response	DC	< 2 μ s
	AC	– 10ms ²
ON to OFF Response	DC	< 2 μ s
	AC	– 10ms ²
Maximum Switching Frequency	DC	250kHz
	AC	~ 30Hz

- 1. All Inputs may be used as standard inputs or high speed inputs independently.*
- 2. 60Hz to 240Hz filter should be set in the software when using an AC line signal.*

BX-DM1E-18ED23 Wiring, Continued

Discrete Input Connection Options

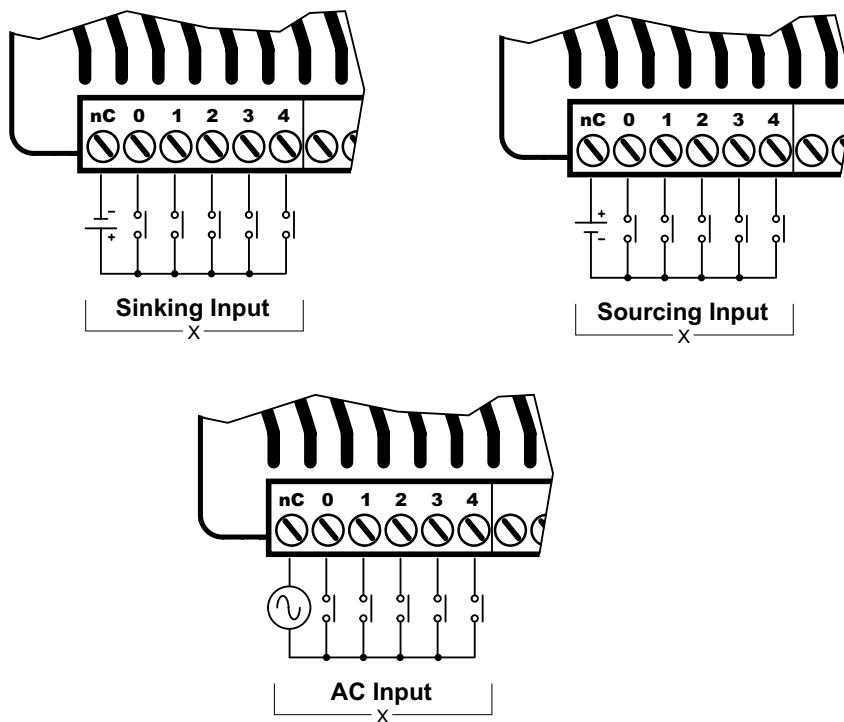

Discrete Input Internal Circuitry *

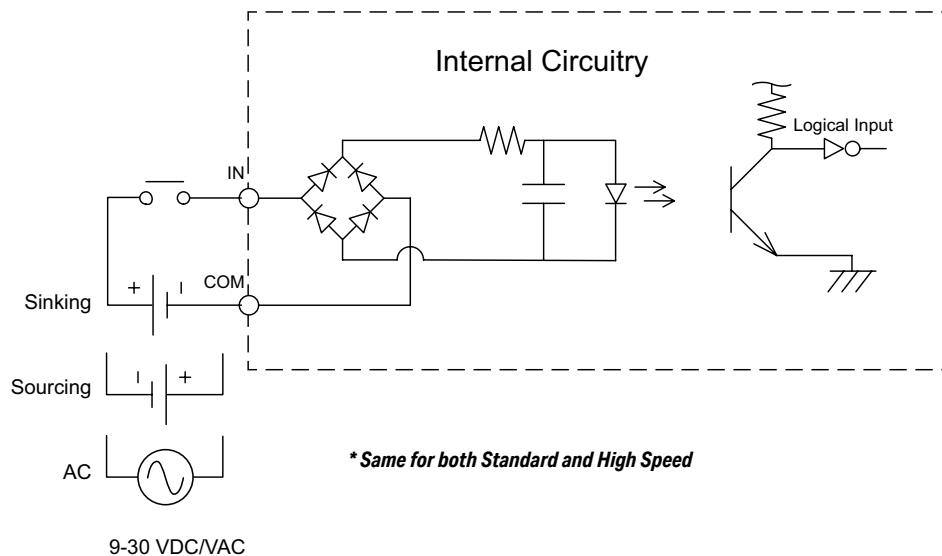

BX-DM1E-18ED23 Wiring, Continued

Discrete Output Specifications

Discrete Output Specifications		
Output Type	Sourcing	
Total Outputs per Module	8	
Commons	2 (4 points/common) Isolated	
Maximum Current per Common	2A	
Nominal Voltage Range	12–24 VDC	
Operating Voltage Range	5–36 VDC	
Maximum Voltage	36VDC	
Minimum Output Current	0.1 mA @ 24VDC	
Maximum Output Current	0.5 A per output No derating over temperature range	
Maximum Inrush Current	5A for 50ms	
Maximum Leakage Current	10 μ A	
ON Voltage Drop	0.05 VDC	
Status Indicators	Logic Side, Green	
Output Details		
Output Type	High-Speed	Standard ¹
Location	Y0...Y3	Y4...Y7
OFF to ON Response	< 2 μ s	< 5ms
ON to OFF Response	< 2 μ s	< 2ms
Maximum Switching Frequency	1m cable - 250kHz 10m cable - 100kHz	~ 100Hz
Overcurrent, Short Circuit Protection and Short to Ground	Current limit by Common Group, self-resetting	N/A
Overcurrent Trip Level ²	Between 4A and 8A	N/A
Fuse Type	User-supplied external fuse	

- All outputs may be used as standard outputs. Only the first 4 outputs (Y0...Y3) are capable of high-speed DC operation.*
- When the high-speed outputs are in an overcurrent situation, the Common terminal Red LED is on. The output LEDs will remain operational even though the output circuitry is turned off and no power is flowing. This condition is not reported to the CPU.*

BX-DM1E-18ED23 Wiring, Continued

Discrete Output Connection Options

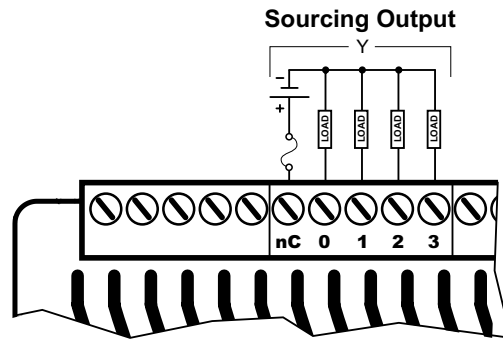

Discrete Standard Output Internal Circuitry

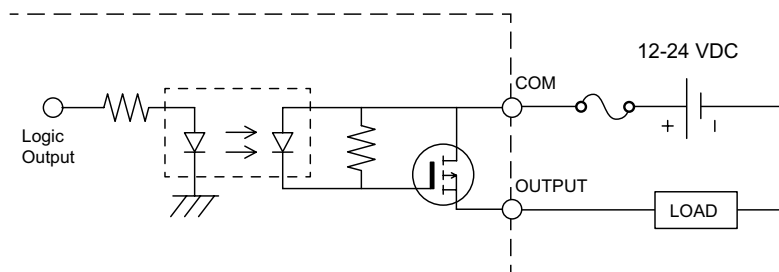

Discrete High-Speed Output Internal Circuitry

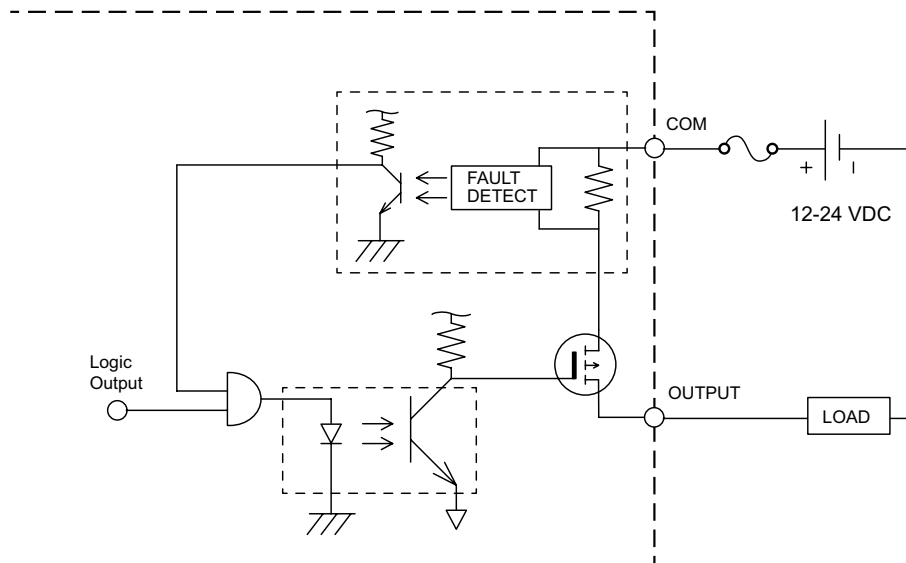

NOTE: When the high speed outputs are in an overcurrent situation, the Common terminal Red LED is on. The output LEDs will remain operational even though the output circuitry is turned off and no power is flowing. This condition is not reported to the CPU.

BX-DM1E-18ED23 Wiring, Continued

Analog Input Specifications

Analog Input Specifications	
Inputs per Module	1
Commons	1
Input Voltage Range *	Software Selectable $\pm 10V$, $\pm 5V$, 0–10 V, 0–5 V
Input Current Range *	Software Selectable $\pm 20mA$, 4–20 mA
Resolution $\pm 10V$, $\pm 20mA$ $\pm 5V$ 0–5 V 4–20 mA 0–10 V	16 bits (0–65535 counts) 15 bits (0–32767 counts) 14 bits (0–16383 counts) ~15 bits (6553–32767 counts) 15 bits (0–32767 counts)
Input Impedance Voltage Modes	100k Ω
Absolute Maximum Input, Voltage Mode	$\pm 30V$
Input Impedance Current Modes	249 Ω
Absolute Maximum Input, Current Mode	$\pm 40mA$ sustained, $\pm 100mA$ for < 5s
Conversion Time	1.2 ms
Input Stability	0.02% of Full Hardware Range = 13 Counts
Full Scale Calibration Error	0.05% of Full Hardware Range = 33 Counts
Offset Calibration Error	0.01% of Full Hardware Range = 7 Counts
Accuracy vs Temperature Error	0.05% of Full Hardware Range = 33 Counts
Maximum Linearity Error (End to End)	0.1% of Full Hardware Range = 66 Counts
Maximum Inaccuracy	0.2% of Full Hardware Range = 131 Counts
Fuse Type	User-supplied external fuse

* *Software selectable per channel*

BX-DM1E-18ED23 Wiring, Continued

Analog Input Connection Options

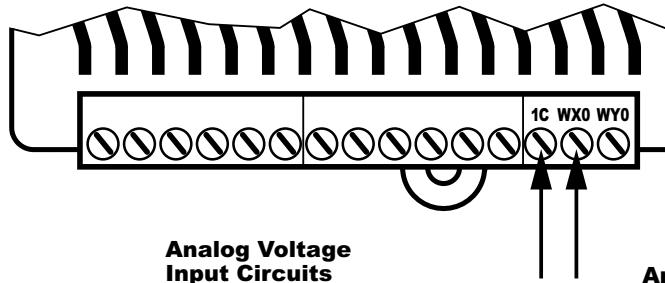

Analog Voltage Input Circuits

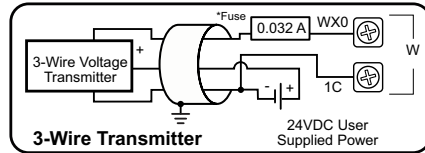
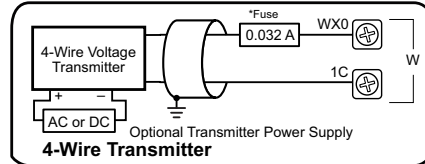

NOTE: Shield should be connected only at one end, to ground at the source device.

Analog Current Sinking Input Circuits

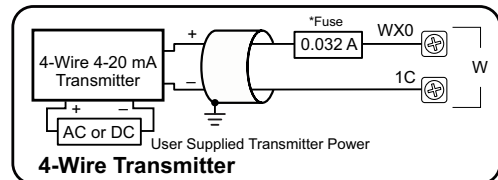
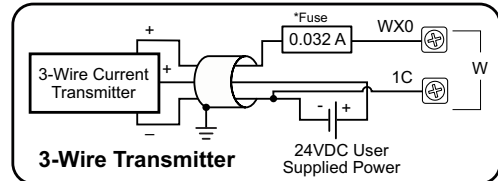
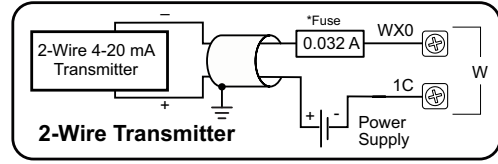

NOTE: Shield should be connected only at one end, to ground at the source device.



NOTE: An Edison S500-32-R 0.032A fast-acting fuse is recommended for all analog voltage inputs, analog outputs, and current loops.

BX-DM1E-18ED23 Wiring, Continued

Analog Output Specifications

Analog Output Specifications	
Outputs per Module	1
Commons	1
Output Voltage Range *	Software Selectable $\pm 10V$, $\pm 5V$, $0-10 V$, $0-5 V$
Output Current Range *	Software Selectable $\pm 20mA$, $4-20 mA$
Resolution $\pm 10V$, $\pm 20mA$ $\pm 5V$ $0-5 V$ $4-20 mA$ $0-10 V$	16 bits (0–65535 counts) 15 bits (0–32767 counts) 14 bits (0–16383 counts) ~15 bits (6553–32767 counts) 15 bits (0–32767 counts)
Minimum Voltage Load Impedance	1k Ω
Maximum Current Load Impedance	500 Ω
Maximum Rating	Continuous Short Circuit Protected
Settling Time	< 1ms
Output Stability	0.02% of Full Hardware Range = 13 Counts
Full Scale Calibration Error	0.05% of Full Hardware Range = 33 Counts
Offset Calibration Error	0.01% of Full Hardware Range = 7 Counts
Accuracy vs Temperature Error	0.05% of Full Hardware Range = 33 Counts
Maximum Linearity Error (End to End)	0.1% of Full Hardware Range = 66 Counts
Maximum Inaccuracy	0.2% of Full Hardware Range = 131 Counts
Fuse Type	User-supplied external fuse

* Software selectable per channel

Analog Output Connection Options

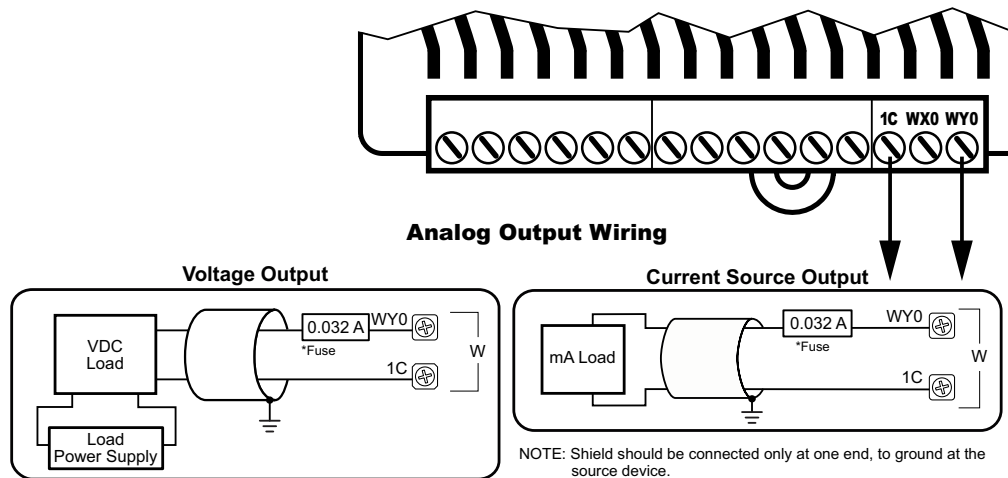

NOTE: An Edison S500-32-R 0.032A fast-acting fuse is recommended for all analog voltage inputs, analog outputs, and current loops.

BX-DM1E-18ED23-D Wiring

This MPU is made up of 18 discrete I/O points. The connections are grouped as follows:

- 10 discrete inputs - sinking/sourcing; rated for 12–24 VAC/VDC. They are located along the bottom of the unit; configured in two (2) groups of 6 terminals, each comprised of 5 inputs and an isolated common.
- 8 discrete outputs - sourcing; rated at 12–24 VDC. They are located along the top of the unit starting to the right of the 24VDC external power supply terminals. The outputs are configured in two (2) groups of 5 terminals, each comprised of 4 outputs and an isolated common..
- 1 analog input and 1 analog output. They are located along the bottom of the unit to the right of the discrete inputs. The analogs are a group of three (3) terminals, comprised of 1 input, 1 output and a shared isolated common. The analog share these common features:
 - current or voltage selectable through software,
 - 16-bit resolution @ $\pm 20\text{mA}$, $\pm 10\text{VDC}$
 - current signal ranges of 4–20 mA, $\pm 20\text{mA}$,
 - voltage signal ranges of 0–5 VDC, 0–10 VDC, $\pm 5\text{VDC}$, $\pm 10\text{VDC}$.

This MPU requires an external 12–24 VDC power supply. The DC power supply connection is located on the top left side of the unit. There is no 24VDC auxiliary output supply.



BX-DM1E-18E23-D



NOTE: Eight (8) Expansion Modules can be connected to extend I/O capacity.

BX-DM1E-18ED23-D, Continued

Power Supply Specifications

Power Supply Specifications	
Nominal Voltage Range*	12–24 VDC
Input Voltage Range (Tolerance)*	10–36 VDC
Maximum Input Voltage Ripple	< ±10%
Maximum Input Power	30W
Cold Start Inrush Current	5A, 2ms
Maximum Inrush Current (Hot Start)	5A, 2ms
Internal Input Protection	Reverse polarity protection and undervoltage lockout via transistor circuit
Acceptable External Power Drop Time	10ms
Under Input Voltage Lock-out	<9VDC
Heat Dissipation	15.4 W Max
Isolated User 24VDC Output	None
Voltage Withstand (dielectric)	1500VAC power Inputs to ground applied for 1 minute
Insulation Resistance	>10MΩ @ 500VDC
Software Version Required	Do-more! Designer version 2.0 or later

* Class 2 or LPS Power Supply required.

Power Supply Connections

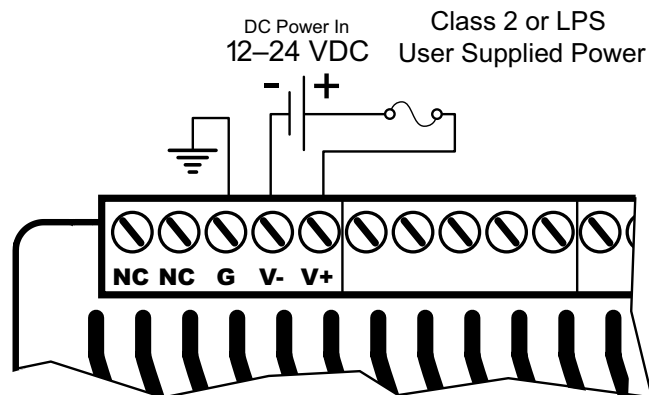

WARNING: No External AC power supply needed on this unit. The two terminals marked "NC" are not used. These terminals are not internally connected. **DO NOT CONNECT ANYTHING TO THESE TERMINALS!**



WARNING: The BRX System **MUST** have a proper earth ground. Do not operate the BRX MPU without proper earth grounding.

BX-DM1E-18ED23-D Wiring, Continued

Discrete Input Specifications

Discrete Input Specifications		
Input Type	Sink/Source	
Total Inputs per Module	10	
Commons	2 (5 points/common) Isolated	
Nominal Voltage Range	12–24 VAC/VDC	
Input Voltage Range	9–30 VAC/VDC	
Maximum Voltage	30 VAC/VDC	
DC Frequency	0–250 kHz - High-speed	
Minimum Pulse Width	0.5 μ s - High-speed	
AC Frequency	47–63 Hz ²	
Input Impedance	3k Ω @ 24VDC	
Input Current (typical)	6mA @ 24 VAC/VDC	
Maximum Input Current	12mA @ 30 VAC/VDC	
ON Voltage Level	> 9.0 VAC/VDC	
OFF Voltage Level	< 2.0 VAC/VDC	
Maximum OFF Current	1.5 mA	
Status Indicators	Logic Side, Green	
Input Details		
Input Type	High-Speed DC	Standard ¹
Location	X0...X9	
OFF to ON Response	DC	< 2 μ s
	AC	– 10ms ²
ON to OFF Response	DC	< 2 μ s
	AC	– 10ms ²
Maximum Switching Frequency	DC	250kHz
	AC	~ 30Hz

1. All Inputs may be used as standard inputs or high speed inputs independently.
2. 60Hz to 240Hz filter should be set in the software when using an AC line signal.

BX-DM1E-18ED23-D Wiring, Continued

Discrete Input Connection Options

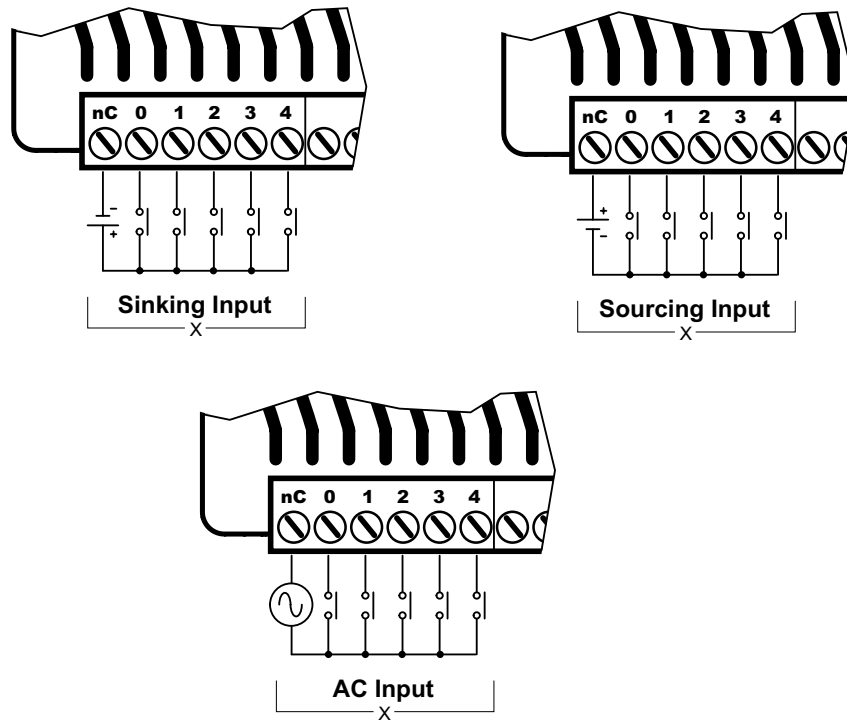

Discrete Input Internal Circuitry *

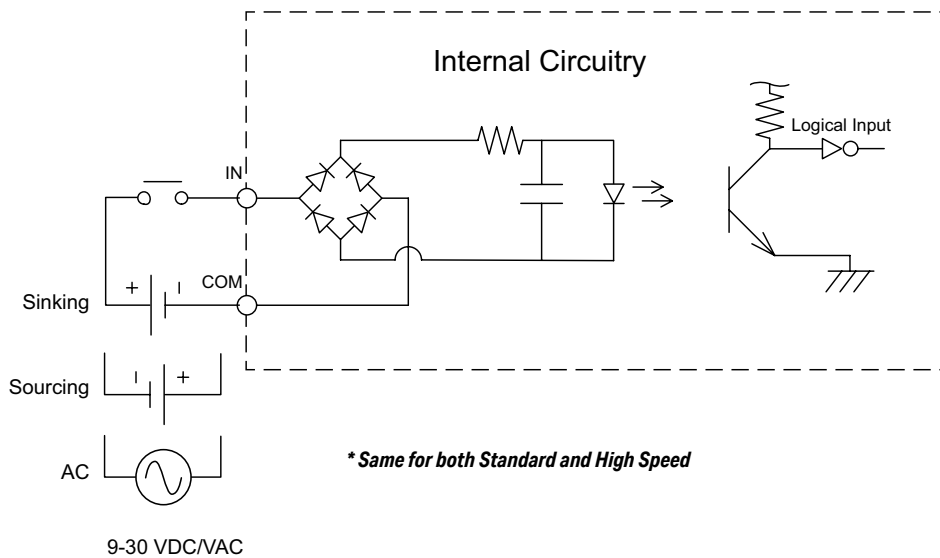

BX-DM1E-18ED23-D Wiring, Continued

Discrete Output Specifications

Discrete Output Specifications		
Output Type	Sourcing	
Total Outputs per Module	8	
Commons	2 (4 points/common) Isolated	
Maximum Current per Common	2A	
Nominal Voltage Range	12–24 VDC	
Operating Voltage Range	5–36 VDC	
Maximum Voltage	36VDC	
Minimum Output Current	0.1 mA @ 24VDC	
Maximum Output Current	0.5 A per output No derating over temperature range	
Maximum Inrush Current	5A for 50ms	
Maximum Leakage Current	10µA	
ON Voltage Drop	0.05 VDC	
Status Indicators	Logic Side, Green	
Output Details		
Output Type	High-Speed	Standard ¹
Location	Y0...Y3	Y4...Y7
OFF to ON Response	< 2µs	< 5ms
ON to OFF Response	< 2µs	< 2ms
Maximum Switching Frequency	1m cable - 250kHz 10m cable - 100kHz	~ 100Hz
Overcurrent, Short Circuit Protection and Short to Ground	Current limit by Common Group, self-resetting	N/A
Overcurrent Trip Level ²	Between 4A and 8A	N/A
Fuse Type	User-supplied external fuse	

1. All outputs may be used as standard outputs. Only the first 4 outputs (Y0...Y3) are capable of high-speed DC operation.

2. When the high-speed outputs are in an overcurrent situation, the Common terminal Red LED is on. The output LEDs will remain operational even though the output circuitry is turned off and no power is flowing. This condition is not reported to the CPU.

BX-DM1E-18ED23-D Wiring, Continued

Discrete Output Connection Options

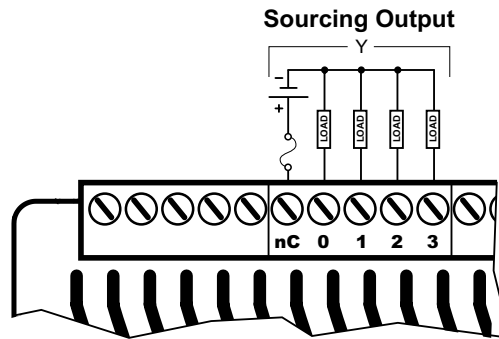

Discrete Standard Output Internal Circuitry

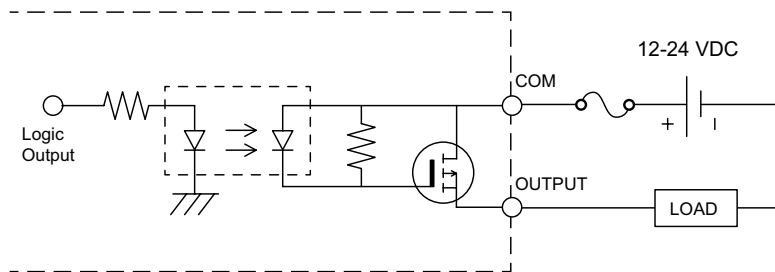

Discrete High-Speed Output Internal Circuitry

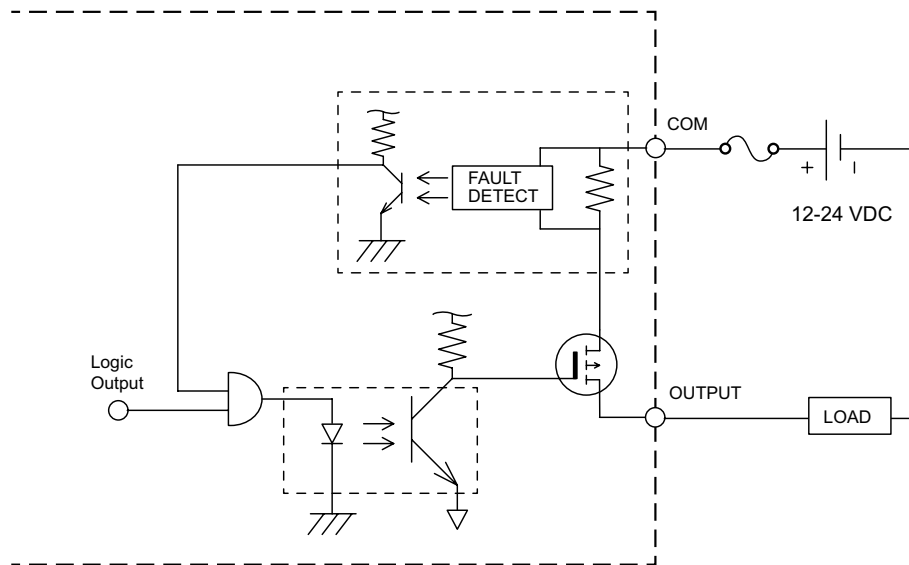

NOTE: When the high speed outputs are in an overcurrent situation, the Common terminal Red LED is on. The output LEDs will remain operational even though the output circuitry is turned off and no power is flowing. This condition is not reported to the CPU.

BX-DM1E-18ED23-D Wiring, Continued

Analog Input Specifications

Analog Input Specifications	
Inputs per Module	1
Commons	1
Input Voltage Range *	Software Selectable $\pm 10V$, $\pm 5V$, $0-10 V$, $0-5 V$
Input Current Range *	Software Selectable $\pm 20mA$, $4-20 mA$
Resolution $\pm 10V$, $\pm 20mA$ $\pm 5V$ $0-5 V$ $4-20 mA$ $0-10 V$	16 bits (0–65535 counts) 15 bits (0–32767 counts) 14 bits (0–16383 counts) ~15 bits (6553–32767 counts) 15 bits (0–32767 counts)
Input Impedance Voltage Modes	100k Ω
Absolute Maximum Input, Voltage Mode	$\pm 30V$
Input Impedance Current Modes	249 Ω
Absolute Maximum Input, Current Mode	$\pm 40mA$ sustained, $\pm 100mA$ for < 5s
Conversion Time	1.2 ms
Input Stability	0.02% of Full Hardware Range = 13 Counts
Full Scale Calibration Error	0.05% of Full Hardware Range = 33 Counts
Offset Calibration Error	0.01% of Full Hardware Range = 7 Counts
Accuracy vs Temperature Error	0.05% of Full Hardware Range = 33 Counts
Maximum Linearity Error (End to End)	0.1% of Full Hardware Range = 66 Counts
Maximum Inaccuracy	0.2% of Full Hardware Range = 131 Counts
Fuse Type	User-supplied external fuse

* Software selectable per channel

BX-DM1E-18ED23-D Wiring, Continued

Analog Input Connection Options

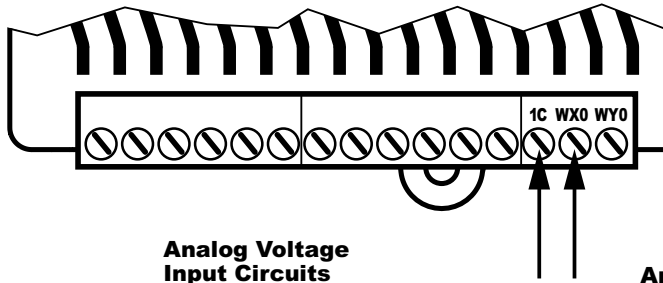

Analog Voltage Input Circuits

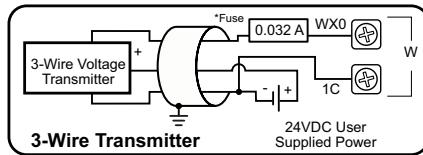
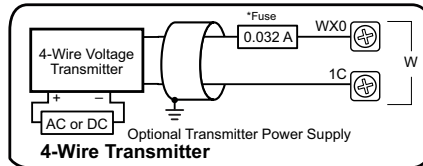

NOTE: Shield should be connected only at one end, to ground at the source device.

Analog Current Sinking Input Circuits

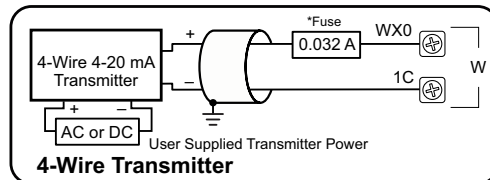
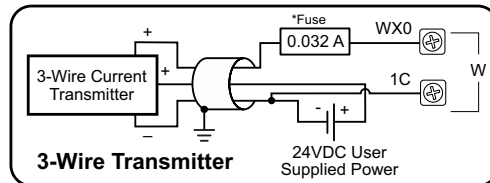
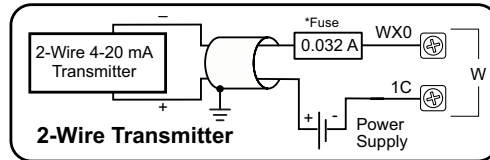

NOTE: Shield should be connected only at one end, to ground at the source device.



NOTE: An Edison S500-32-R 0.032A fast-acting fuse is recommended for all analog voltage inputs, analog outputs, and current loops.

BX-DM1E-18ED23-D Wiring, Continued

Analog Output Specifications

Analog Output Specifications	
Outputs per Module	1
Commons	1
Output Voltage Range *	Software Selectable $\pm 10\text{V}$, $\pm 5\text{V}$, $0\text{--}10\text{ V}$, $0\text{--}5\text{ V}$
Output Current Range *	Software Selectable $\pm 20\text{mA}$, $4\text{--}20\text{ mA}$
Resolution $\pm 10\text{V}$, $\pm 20\text{mA}$ $\pm 5\text{V}$ $0\text{--}5\text{ V}$ $4\text{--}20\text{ mA}$ $0\text{--}10\text{ V}$	16 bits (0–65535 counts) 15 bits (0–32767 counts) 14 bits (0–16383 counts) ~15 bits (6553–32767 counts) 15 bits (0–32767 counts)
Minimum Voltage Load Impedance	1k Ω
Maximum Current Load Impedance	500 Ω
Maximum Rating	Continuous Short Circuit Protected
Settling Time	< 1ms
Output Stability	0.02% of Full Hardware Range = 13 Counts
Full Scale Calibration Error	0.05% of Full Hardware Range = 33 Counts
Offset Calibration Error	0.01% of Full Hardware Range = 7 Counts
Accuracy vs Temperature Error	0.05% of Full Hardware Range = 33 Counts
Maximum Linearity Error (End to End)	0.1% of Full Hardware Range = 66 Counts
Maximum Inaccuracy	0.2% of Full Hardware Range = 131 Counts
Fuse Type	User-supplied external fuse

* Software selectable per channel

Analog Output Connection Options

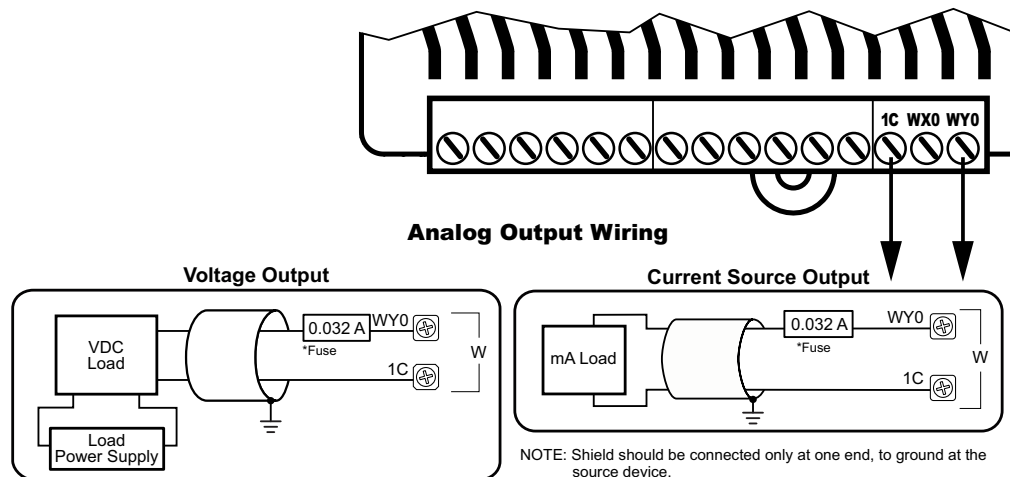

NOTE: An Edison S500-32-R 0.032A fast-acting fuse is recommended for all analog voltage inputs, analog outputs, and current loops.

BX-DM1E-18ER3 Wiring

This MPU is made up of 18 discrete I/O points. The connections are grouped as follows:

- 10 discrete inputs - sinking/sourcing; rated for 12–24 VAC/VDC. They are located along the bottom of the unit; configured in two (2) groups of 6 terminals, each comprised of 5 inputs and an isolated common.
- 8 discrete outputs - Form A Relay (SPST); rated 12–48 VDC/ 24–240 VAC. They are located along the top of the unit starting to the right of the 24VDC auxiliary output terminals. The outputs are configured in two (2) groups of 5 terminals, each comprised of 4 outputs and an isolated common.
- 1 analog input and 1 analog output. They are located along the bottom of the unit to the right of the discrete inputs. The analogs are a group of three (3) terminals, comprised of 1 input, 1 output and a shared isolated common. The analogs share these common features:
 - current or voltage selectable through software,
 - 16-bit resolution @ $\pm 20\text{mA}$, $\pm 10\text{VDC}$
 - current signal ranges of 4–20 mA, $\pm 20\text{mA}$,
 - voltage signal ranges of 0–5 VDC, 0–10 VDC, $\pm 5\text{VDC}$, $\pm 10\text{VDC}$.

This MPU requires an external 120–240 VAC power supply. The AC power supply connection and the 24VDC auxiliary output supply terminals are located on the top left side of the unit.

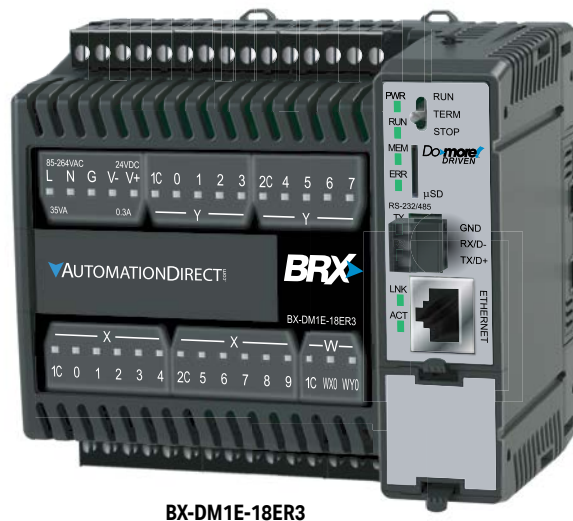

NOTE: Eight (8) Expansion Modules can be connected to extend I/O capacity.

BX-DM1E-18ER3 Wiring, Continued

Power Supply Specifications

Power Supply Specifications	
Nominal Voltage Range	120–240 VAC
Input Voltage Range (Tolerance)	85–264 VAC
Rated Operating Frequency	47–63 Hz
Maximum Input Power	40VA
Cold Start Inrush Current	1.5 A, 2ms
Maximum Inrush Current (Hot Start)	1.5 A, 2ms
Internal Input Fuse Protection	Micro fuse 250V, 2A Non-replaceable
Acceptable External Power Drop Time	10ms
Under Input Voltage Lock-out	80VAC
Input Transient Protection	Input choke and line filter
Heat Dissipation	21.1 W Max
Isolated User 24VDC Output	24VDC @ 0.3 A max, <1V P-P Ripple, Integrated self-resetting short circuit protection
Voltage Withstand (dielectric)	1500VAC Power Inputs to Ground applied for 1 minute 1500VAC Ground to 24VDC Output applied for 1 minute
Insulation Resistance	>10M Ω @ 500VDC
Software Version Required	Do-more! Designer version 2.0 or later

Power Supply Connections

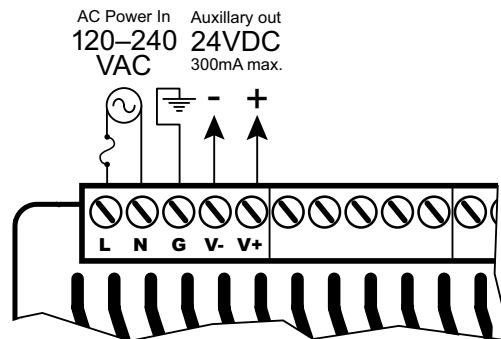

WARNING: Do not exceed the 24VDC auxiliary power supply load limit of 300mA.



WARNING: The BRX System **MUST** have a proper earth ground. Do not operate the BRX MPU without proper earth grounding.

BX-DM1E-18ER3 Wiring, Continued

Discrete Input Specifications

Discrete Input Specifications		
Input Type	Sink/Source	
Total Inputs per Module	10	
Commons	2 (5 points/common) Isolated	
Nominal Voltage Range	12–24 VAC/VDC	
Input Voltage Range	9–30 VAC/VDC	
Maximum Voltage	30 VAC/VDC	
DC Frequency	0–250 kHz - High-speed	
Minimum Pulse Width	0.5 μ s - High-speed	
AC Frequency	47–63 Hz ²	
Input Impedance	3k Ω @ 24VDC	
Input Current (typical)	6mA @ 24 VAC/VDC	
Maximum Input Current	12mA @ 30 VAC/VDC	
ON Voltage Level	> 9.0 VAC/VDC	
OFF Voltage Level	< 2.0 VAC/VDC	
Maximum OFF Current	1.5 mA	
Status Indicators	Logic Side, Green	
Input Details		
Input Type	High-Speed DC	Standard ¹
Location	X0...X9	
OFF to ON Response	DC	< 2 μ s
	AC	– 10ms ²
ON to OFF Response	DC	< 2 μ s
	AC	– 10ms ²
Maximum Switching Frequency	DC	250kHz
	AC	~ 30Hz

1. All Inputs may be used as standard inputs or high speed inputs independently.
2. 60Hz to 240Hz filter should be set in the software when using an AC line signal.

BX-DM1E-18ER3 Wiring, Continued

Discrete Input Connection Options

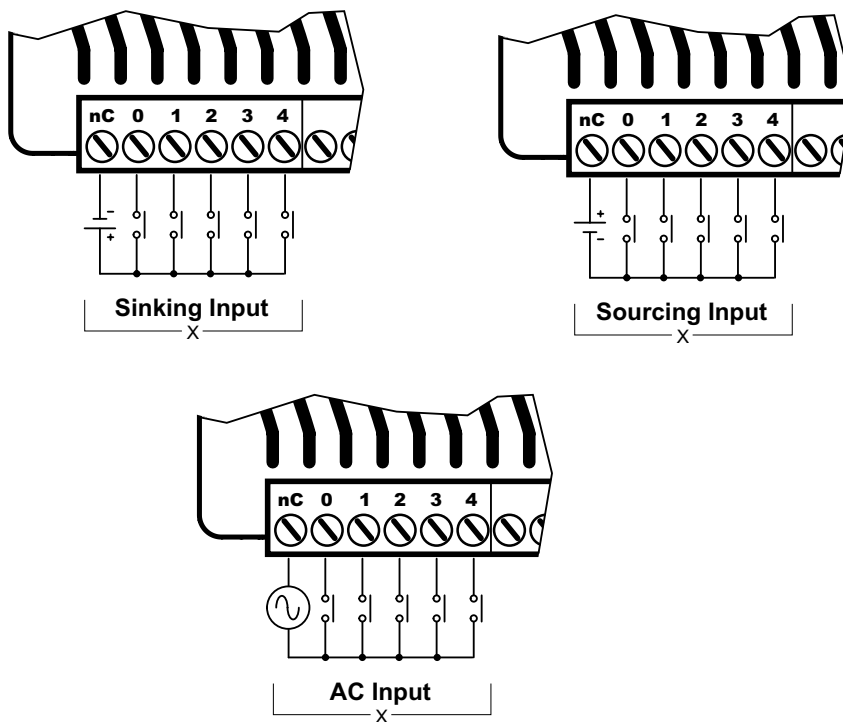

Discrete Input Internal Circuitry *

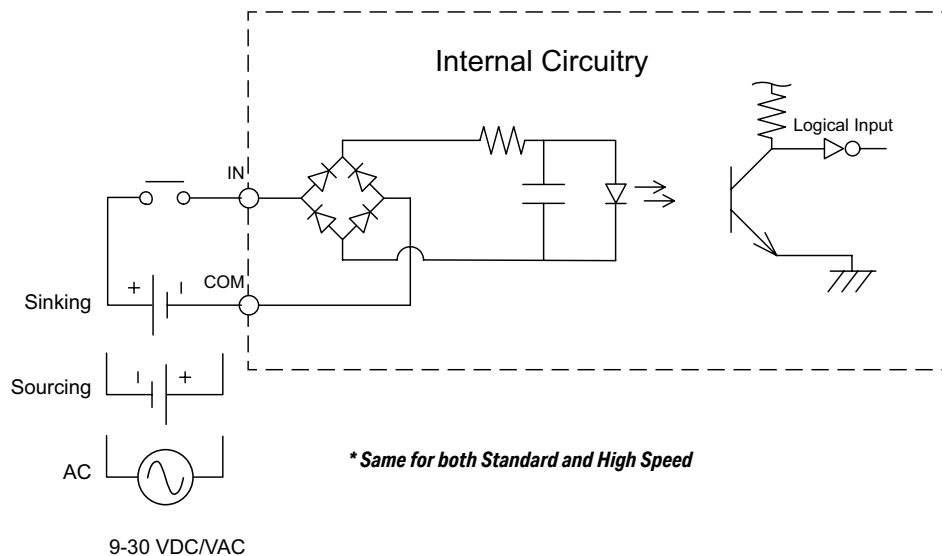

BX-DM1E-18ER3 Wiring, Continued

Discrete Output Specifications

Discrete Output Specifications	
Output Type	Relay Form A (SPST)
Total Outputs per Module	8
Commons	2 (4 points/common) Isolated
Maximum Current per Common	8A
Nominal Voltage Range	12–48 VDC 24–240 VAC
Operating Voltage Range	5–60 VDC 5–264 VAC
Maximum Voltage	60VDC 264VAC
Minimum Output Current	0.1 mA @ 24VDC 0.1 mA @ 24VAC
Maximum Output Current	2A
Maximum Inrush Current	5A for 50ms
Maximum Leakage Current	1 μ A (DC), 300 μ A (AC) due to RC snubber circuit
ON Voltage Drop	0.2 V Max
Status Indicators	Logic Side, Green
Output Details	
Output Type	Standard
Location	Y0...Y7
ON-OFF Response	<10ms
OFF-ON Response	<10ms
Maximum Switching Frequency	10Hz
Relay Cycle Life Mechanical Endurance Electrical Endurance	5 million operations 120,000 operations
Fuse Type	User-supplied external fuse

BX-DM1E-18ER3 Wiring, Continued

Discrete Output Connection Options

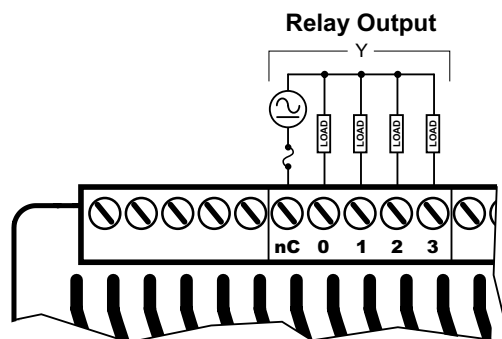

Discrete Standard Output Internal Circuitry

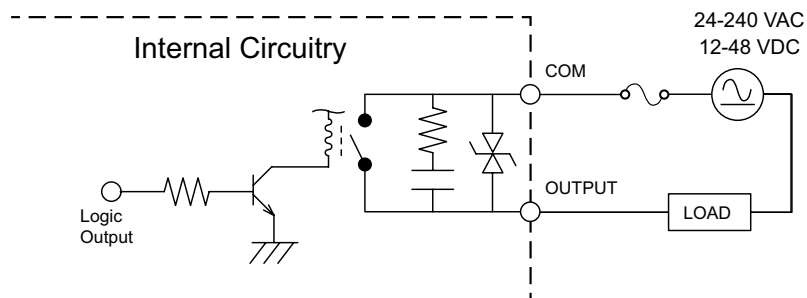

BX-DM1E-18ER3 Wiring, Continued

Analog Input Specifications

Analog Input Specifications	
Inputs per Module	1
Commons	1
Input Voltage Range *	Software Selectable $\pm 10V$, $\pm 5V$, 0–10 V, 0–5 V
Input Current Range *	Software Selectable $\pm 20mA$, 4–20 mA
Resolution $\pm 10V$, $\pm 20mA$ $\pm 5V$ 0–5 V 4–20 mA 0–10 V	16 bits (0–65535 counts) 15 bits (0–32767 counts) 14 bits (0–16383 counts) ~15 bits (6553–32767 counts) 15 bits (0–32767 counts)
Input Impedance Voltage Modes	100k Ω
Absolute Maximum Input, Voltage Mode	$\pm 30V$
Input Impedance Current Modes	249 Ω
Absolute Maximum Input, Current Mode	$\pm 40mA$ sustained, $\pm 100mA$ for < 5s
Conversion Time	1.2 ms
Input Stability	0.02% of Full Hardware Range = 13 Counts
Full Scale Calibration Error	0.05% of Full Hardware Range = 33 Counts
Offset Calibration Error	0.01% of Full Hardware Range = 7 Counts
Accuracy vs Temperature Error	0.05% of Full Hardware Range = 33 Counts
Maximum Linearity Error (End to End)	0.1% of Full Hardware Range = 66 Counts
Maximum Inaccuracy	0.2% of Full Hardware Range = 131 Counts
Fuse Type	User-supplied external fuse

* *Software selectable per channel*

BX-DM1E-18ER3 Wiring, Continued

Analog Input Connection Options

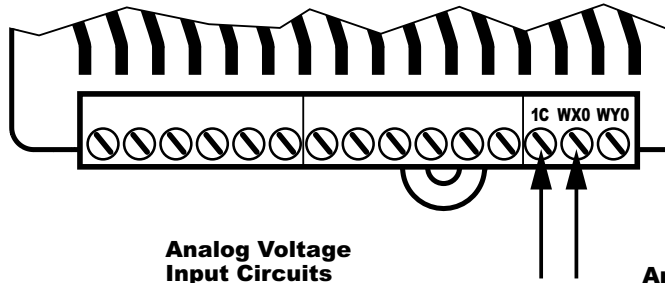

Analog Voltage Input Circuits

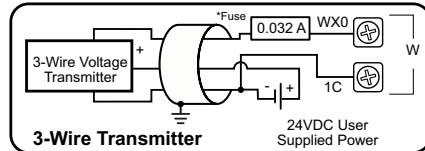
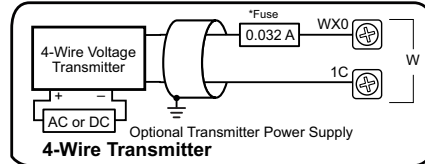

NOTE: Shield should be connected only at one end, to ground at the source device.

Analog Current Sinking Input Circuits

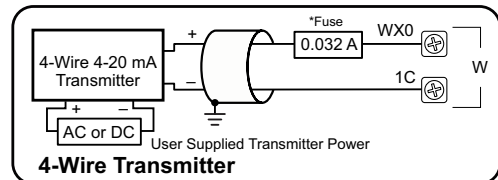
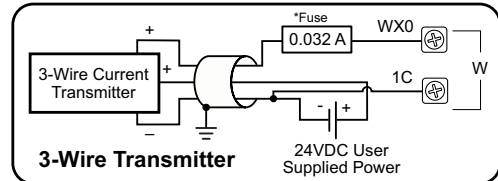
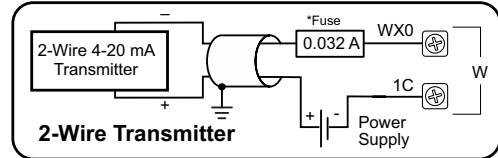

NOTE: Shield should be connected only at one end, to ground at the source device.



NOTE: An Edison S500-32-R 0.032A fast-acting fuse is recommended for all analog voltage inputs, analog outputs, and current loops.

BX-DM1E-18ER3 Wiring, Continued

Analog Output Specifications

Analog Output Specifications	
Outputs per Module	1
Commons	1
Output Voltage Range *	Software Selectable $\pm 10V$, $\pm 5V$, $0-10 V$, $0-5 V$
Output Current Range *	Software Selectable $\pm 20mA$, $4-20 mA$
Resolution $\pm 10V$, $\pm 20mA$ $\pm 5V$ $0-5 V$ $4-20 mA$ $0-10 V$	16 bits (0–65535 counts) 15 bits (0–32767 counts) 14 bits (0–16383 counts) ~15 bits (6553–32767 counts) 15 bits (0–32767 counts)
Minimum Voltage Load Impedance	1k Ω
Maximum Current Load Impedance	500 Ω
Maximum Rating	Continuous Short Circuit Protected
Settling Time	< 1ms
Output Stability	0.02% of Full Hardware Range = 13 Counts
Full Scale Calibration Error	0.05% of Full Hardware Range = 33 Counts
Offset Calibration Error	0.01% of Full Hardware Range = 7 Counts
Accuracy vs Temperature Error	0.05% of Full Hardware Range = 33 Counts
Maximum Linearity Error (End to End)	0.1% of Full Hardware Range = 66 Counts
Maximum Inaccuracy	0.2% of Full Hardware Range = 131 Counts
Fuse Type	User-supplied external fuse

* Software selectable per channel

Analog Output Connection Options

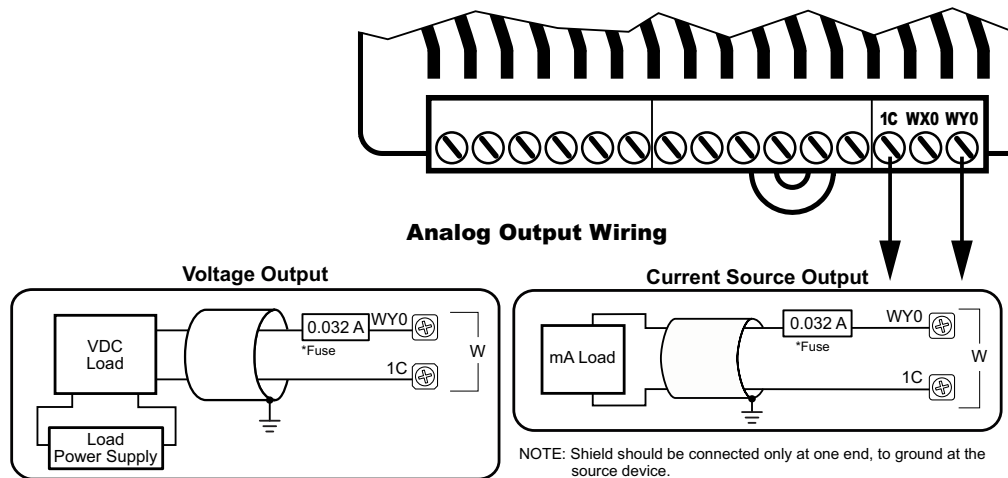

NOTE: An Edison S500-32-R 0.032A fast-acting fuse is recommended for all analog voltage inputs, analog outputs, and current loops.

BX-DM1E-18ER3-D Wiring

This MPU is made up of 18 discrete I/O points. The connections are grouped as follows:

- 10 discrete inputs - sinking/sourcing; rated for 12–24 VAC/VDC. They are located along the bottom of the unit; configured in two (2) groups of 6 terminals, each comprised of 5 inputs and an isolated common.
- 8 discrete outputs - Form A Relay (SPST); rated 12–48 VDC/ 24–240 VAC. They are located along the top of the unit starting to the right of the 24VDC external power supply terminals. The outputs are configured in two (2) groups of 5 terminals, each comprised of 4 outputs and an isolated common.
- 1 analog input and 1 analog output. They are located along the bottom of the unit to the right of the discrete inputs. The analogs are a group of three (3) terminals, comprised of 1 input, 1 output and a shared isolated common. The analogs share these common features:
 - current or voltage selectable through software
 - 16-bit resolution @ $\pm 20\text{mA}$, $\pm 10\text{VDC}$
 - current signal ranges of 4–20 mA, $\pm 20\text{mA}$
 - voltage signal ranges of 0–5 VDC, 0–10 VDC, $\pm 5\text{VDC}$, $\pm 10\text{VDC}$

This MPU requires an external 12–24 VDC power supply. The DC power supply connection is located on the top left side of the unit. There is no 24VDC auxiliary output supply.

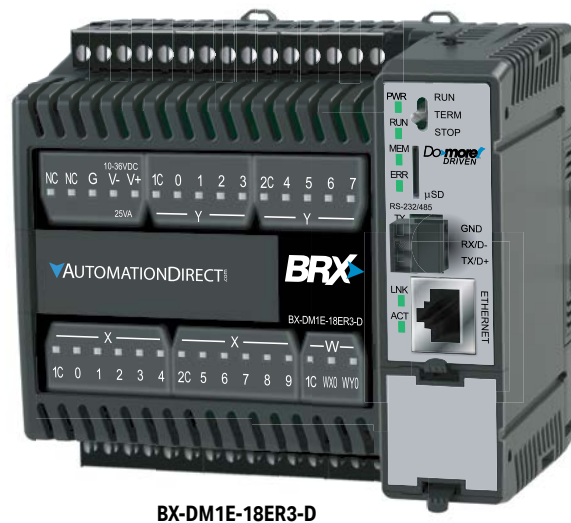

BX-DM1E-18ER3-D



NOTE: Eight (8) Expansion Modules can be connected to extend I/O capacity.

BX-DM1E-18ER3-D Wiring, Continued

Power Supply Specifications

Power Supply Specifications	
Nominal Voltage Range*	12–24 VDC
Input Voltage Range (Tolerance)*	10–36 VDC
Maximum Input Voltage Ripple	< ±10%
Maximum Input Power	30W
Cold Start Inrush Current	5A, 2ms
Maximum Inrush Current (Hot Start)	5A, 2ms
Internal Input Protection	Reverse polarity protection and undervoltage lockout via transistor circuit
Acceptable External Power Drop Time	10ms
Under Input Voltage Lock-out	<9VDC
Heat Dissipation	18.9 W Max
Isolated User 24VDC Output	None
Voltage Withstand (dielectric)	1500VAC power Inputs to ground applied for 1 minute
Insulation Resistance	>10MΩ @ 500VDC
Software Version Required	Do-more! Designer version 2.0 or later

* Class 2 or LPS Power Supply required.

Power Supply Connections

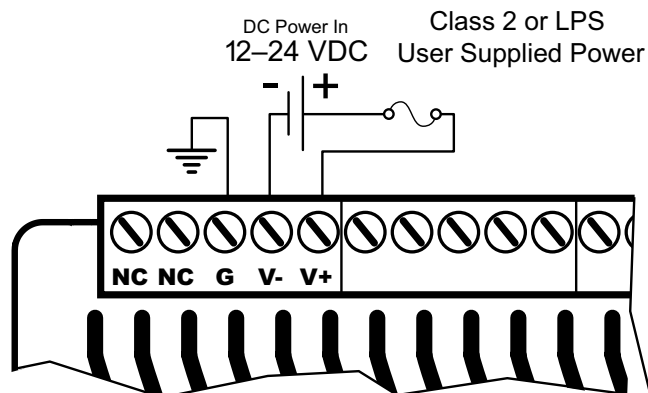

WARNING: No External AC power supply needed on this unit. The two terminals marked "NC" are not used. These terminals are not internally connected. **DO NOT CONNECT ANYTHING TO THESE TERMINALS!**



WARNING: The BRX System **MUST** have a proper earth ground. Do not operate the BRX MPU without proper earth grounding.

BX-DM1E-18ER3-D Wiring, Continued

Discrete Input Specifications

Discrete Input Specifications		
Input Type	Sink/Source	
Total Inputs per Module	10	
Commons	2 (5 points/common) Isolated	
Nominal Voltage Range	12–24 VAC/VDC	
Input Voltage Range	9–30 VAC/VDC	
Maximum Voltage	30 VAC/VDC	
DC Frequency	0–250 kHz - High-speed	
Minimum Pulse Width	0.5 μ s - High-speed	
AC Frequency	47–63 Hz ²	
Input Impedance	3k Ω @ 24VDC	
Input Current (typical)	6mA @ 24 VAC/VDC	
Maximum Input Current	12mA @ 30 VAC/VDC	
ON Voltage Level	> 9.0 VAC/VDC	
OFF Voltage Level	< 2.0 VAC/VDC	
Maximum OFF Current	1.5 mA	
Status Indicators	Logic Side, Green	
Input Details		
Input Type	High-Speed DC	Standard ¹
Location	X0...X9	
OFF to ON Response	DC	< 2 μ s
	AC	– 10ms ²
ON to OFF Response	DC	< 2 μ s
	AC	– 10ms ²
Maximum Switching Frequency	DC	250kHz
	AC	~ 30Hz

1. All Inputs may be used as standard inputs or high speed inputs independently.
2. 60Hz to 240Hz filter should be set in the software when using an AC line signal.

BX-DM1E-18ER3-D Wiring, Continued

Discrete Input Connection Options

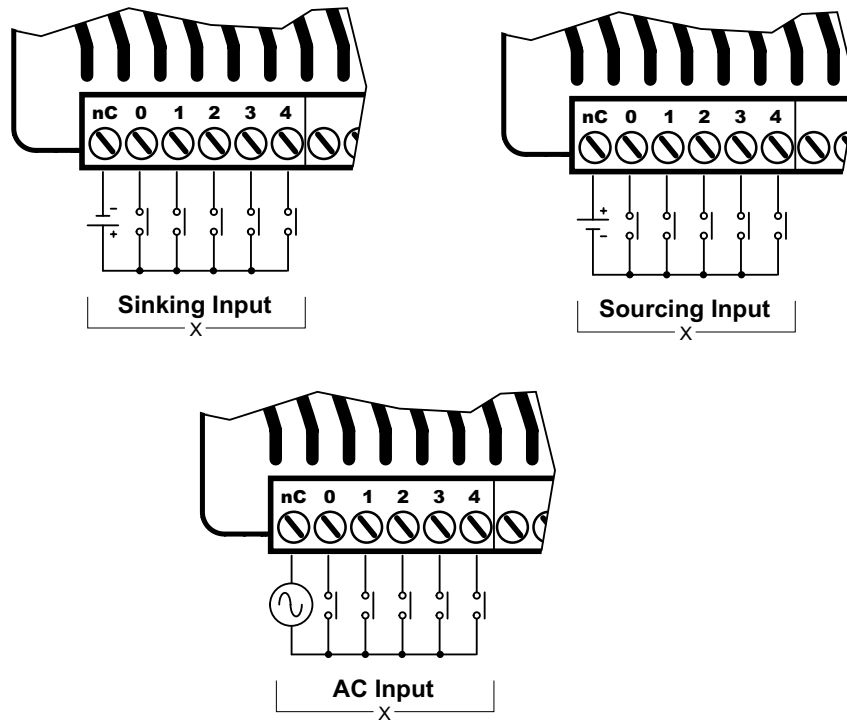

Discrete Input Internal Circuitry *

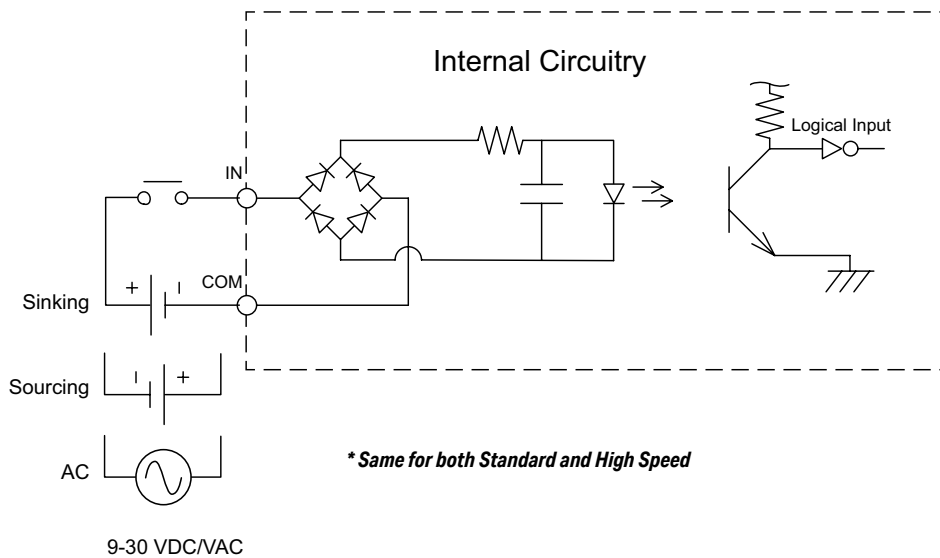

BX-DM1E-18ER3-D Wiring, Continued

Discrete Output Specifications

Discrete Output Specifications	
Output Type	Relay Form A (SPST)
Total Outputs per Module	8
Commons	2 (4 points/common) Isolated
Maximum Current per Common	8A
Nominal Voltage Range	12–48 VDC 24–240 VAC
Operating Voltage Range	5–60 VDC 5–264 VAC
Maximum Voltage	60VDC 264VAC
Minimum Output Current	0.1 mA @ 24VDC 0.1 mA @ 24VAC
Maximum Output Current	2A
Maximum Inrush Current	5A for 50ms
Maximum Leakage Current	1 μ A (DC), 300 μ A (AC) due to RC snubber circuit
ON Voltage Drop	0.2 V Max
Status Indicators	Logic Side, Green
Output Details	
Output Type	Standard
Location	Y0...Y7
ON-OFF Response	<10ms
OFF-ON Response	<10ms
Maximum Switching Frequency	10Hz
Relay Cycle Life	5 million operations
Mechanical Endurance	120,000 operations
Electrical Endurance	
Fuse Type	User-supplied external fuse

BX-DM1E-18ER3-D Wiring, Continued

Discrete Output Connection Options

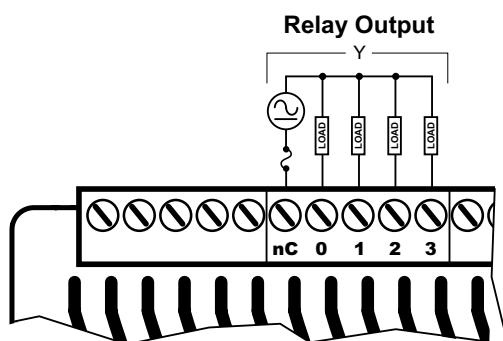

Discrete Standard Output Internal Circuitry

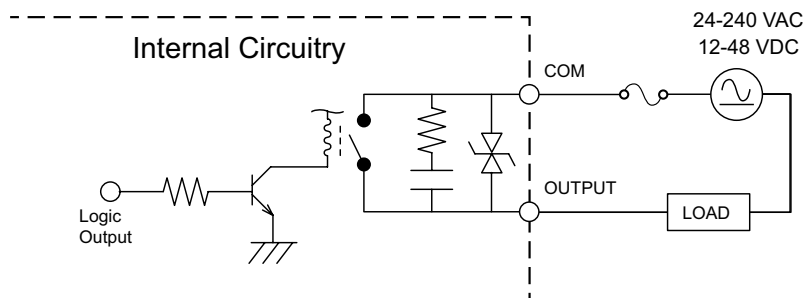

BX-DM1E-18ER3-D Wiring, Continued

Analog Input Specifications

Analog Input Specifications	
Inputs per Module	1
Commons	1
Input Voltage Range *	Software Selectable $\pm 10V$, $\pm 5V$, 0–10 V, 0–5 V
Input Current Range *	Software Selectable $\pm 20mA$, 4–20 mA
Resolution $\pm 10V$, $\pm 20mA$ $\pm 5V$ 0–5 V 4–20 mA 0–10 V	16 bits (0–65535 counts) 15 bits (0–32767 counts) 14 bits (0–16383 counts) ~15 bits (6553–32767 counts) 15 bits (0–32767 counts)
Input Impedance Voltage Modes	100k Ω
Absolute Maximum Input, Voltage Mode	$\pm 30V$
Input Impedance Current Modes	249 Ω
Absolute Maximum Input, Current Mode	$\pm 40mA$ sustained, $\pm 100mA$ for < 5s
Conversion Time	1.2 ms
Input Stability	0.02% of Full Hardware Range = 13 Counts
Full Scale Calibration Error	0.05% of Full Hardware Range = 33 Counts
Offset Calibration Error	0.01% of Full Hardware Range = 7 Counts
Accuracy vs Temperature Error	0.05% of Full Hardware Range = 33 Counts
Maximum Linearity Error (End to End)	0.1% of Full Hardware Range = 66 Counts
Maximum Inaccuracy	0.2% of Full Hardware Range = 131 Counts
Fuse Type	User-supplied external fuse

* *Software selectable per channel*

BX-DM1E-18ER3-D Wiring, Continued

Analog Input Connection Options

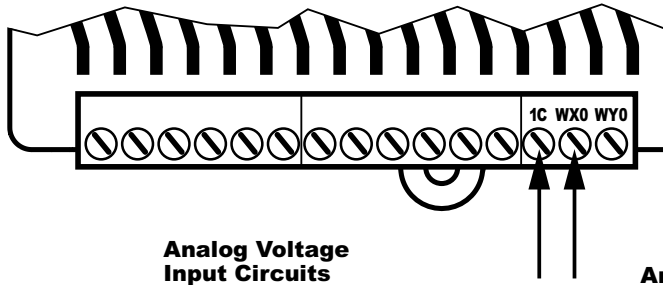

Analog Voltage Input Circuits

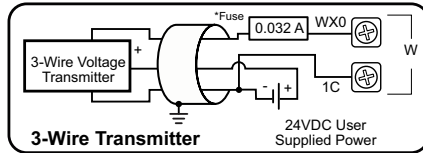
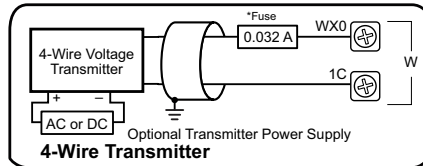

NOTE: Shield should be connected only at one end, to ground at the source device.

Analog Current Sinking Input Circuits

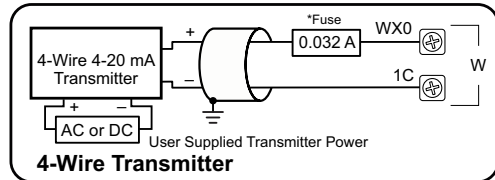
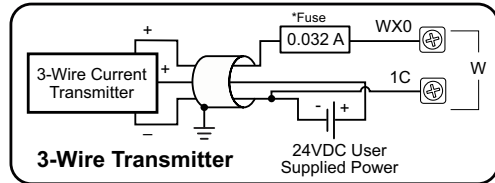
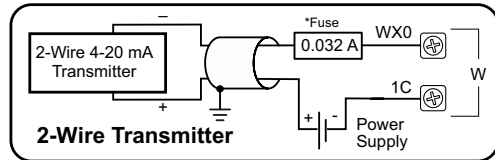

NOTE: Shield should be connected only at one end, to ground at the source device.



NOTE: An Edison S500-32-R 0.032A fast-acting fuse is recommended for all analog voltage inputs, analog outputs, and current loops.

BX-DM1E-18ER3-D Wiring, Continued

Analog Output Specifications

Analog Output Specifications	
Outputs per Module	1
Commons	1
Output Voltage Range *	Software Selectable $\pm 10V$, $\pm 5V$, 0–10 V, 0–5 V
Output Current Range *	Software Selectable $\pm 20mA$, 4–20 mA
Resolution $\pm 10V$, $\pm 20mA$ $\pm 5V$ 0–5 V 4–20 mA 0–10 V	16 bits (0–65535 counts) 15 bits (0–32767 counts) 14 bits (0–16383 counts) ~15 bits (6553–32767 counts) 15 bits (0–32767 counts)
Minimum Voltage Load Impedance	1k Ω
Maximum Current Load Impedance	500 Ω
Maximum Rating	Continuous Short Circuit Protected
Settling Time	< 1ms
Output Stability	0.02% of Full Hardware Range = 13 Counts
Full Scale Calibration Error	0.05% of Full Hardware Range = 33 Counts
Offset Calibration Error	0.01% of Full Hardware Range = 7 Counts
Accuracy vs Temperature Error	0.05% of Full Hardware Range = 33 Counts
Maximum Linearity Error (End to End)	0.1% of Full Hardware Range = 66 Counts
Maximum Inaccuracy	0.2% of Full Hardware Range = 131 Counts
Fuse Type	User-supplied external fuse

* Software selectable per channel

Analog Output Connection Options

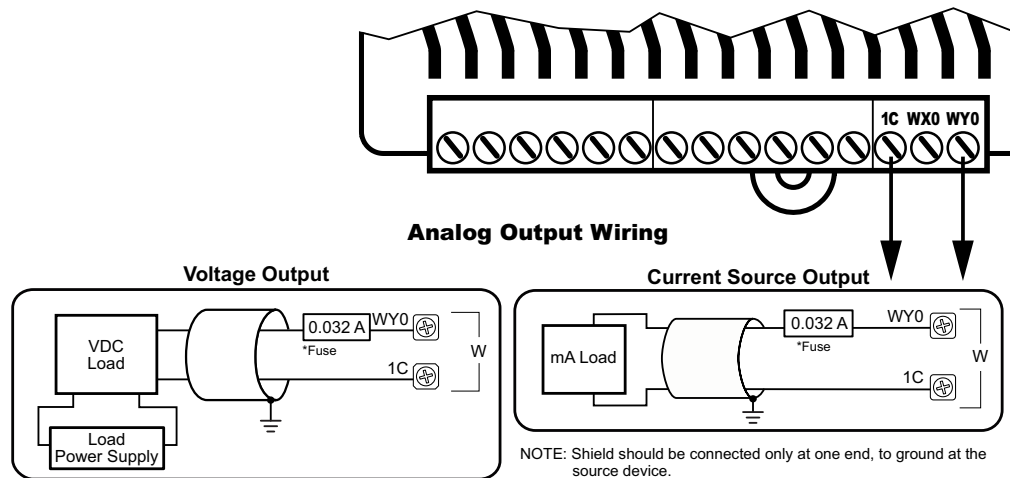

NOTE: An Edison S500-32-R 0.032A fast-acting fuse is recommended for all analog voltage inputs, analog outputs, and current loops.

BX-DM1E-18AR3 Wiring

This MPU is made up of 18 discrete I/O points. The connections are grouped as follows:

- 10 discrete inputs - AC rated for 120–240 VAC. They are located along the bottom of the unit; configured in two (2) groups of 6 terminals, each comprised of 5 inputs and an isolated common.
- 8 discrete outputs - Form A Relay (SPST); rated 12–48 VDC/ 24–240 VAC. They are located along the top of the unit starting to the right of the 24VDC auxiliary output terminals. The outputs are configured in two (2) groups of 5 terminals, each comprised of 4 outputs and an isolated common.
- 1 analog input and 1 analog output. They are located along the bottom of the unit to the right of the discrete inputs. The analogs are a group of three (3) terminals, comprised of 1 input, 1 output and a shared isolated common. The analogs share these common features:
 - current or voltage selectable through software,
 - 16-bit resolution @ $\pm 20\text{mA}$, $\pm 10\text{VDC}$
 - current signal ranges of 4–20 mA, $\pm 20\text{mA}$,
 - voltage signal ranges of 0–5 VDC, 0–10 VDC, $\pm 5\text{VDC}$, $\pm 10\text{VDC}$.

This MPU requires an external 120–240 VAC power supply. The AC power supply connection and the 24VDC auxiliary output supply terminals are located on the top left side of the unit.



BX-DM1E-18AR3



NOTE: Eight (8) Expansion Modules can be connected to extend I/O capacity.

BX-DM1E-18AR3 Wiring, Continued

Power Supply Specifications

Power Supply Specifications	
Nominal Voltage Range	120–240 VAC
Input Voltage Range (Tolerance)	85–264 VAC
Rated Operating Frequency	47–63 Hz
Maximum Input Power	40VA
Cold Start Inrush Current	1.5 A, 2ms
Maximum Inrush Current (Hot Start)	1.5 A, 2ms
Internal Input Fuse Protection	Micro fuse 250V, 2A Non-replaceable
Acceptable External Power Drop Time	10ms
Under Input Voltage Lock-out	80VAC
Input Transient Protection	Input choke and line filter
Heat Dissipation	20.7 W Max
Isolated User 24VDC Output	24VDC @ 0.3 A max, <1V P-P Ripple, Integrated self-resetting short circuit protection
Voltage Withstand (dielectric)	1500VAC Power Inputs to Ground applied for 1 minute 1500VAC Ground to 24VDC Output applied for 1 minute
Insulation Resistance	>10M Ω @ 500VDC
Software Version Required	Do-more! Designer version 2.0 or later

Power Supply Connections

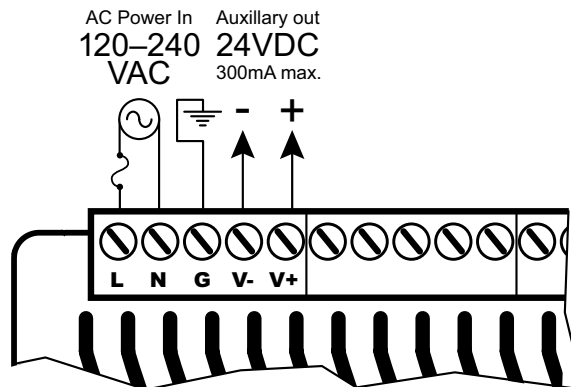

WARNING: Do not exceed the 24VDC auxiliary power supply load limit of 300mA.



WARNING: The BRX System **MUST** have a proper earth ground. Do not operate the BRX MPU without proper earth grounding.

BX-DM1E-18AR3 Wiring, Continued

Discrete Input Specifications

Discrete Input Specifications	
Input Type	AC
Total Inputs per Module	10
Commons	2 (5 points/common) Isolated
Nominal Voltage Range	120–240 VAC
Input Voltage Range	85–264 VAC
Maximum Voltage	264VAC RMS
AC Frequency	47–63 Hz
Input Impedance	15kΩ
Input Current (typical)	9mA @ 120VAC, 13mA @ 220VAC
Maximum Input Current	14mA @ 120VAC, 20mA @ 220VAC
ON Voltage Level	> 85VAC
OFF Voltage Level	< 40VAC
Maximum OFF Current	2.5 mA
Status Indicators	Logic Side, Green
Input Details	
Input Type	Standard
Location	X0...X9
OFF - ON Response	10ms
ON - OFF Response	10ms
Maximum Switching Frequency	~ 30Hz

Discrete Input Connection Options

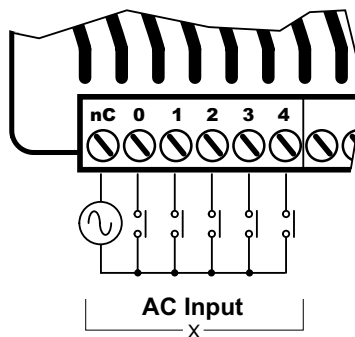

Discrete Input Internal Circuitry

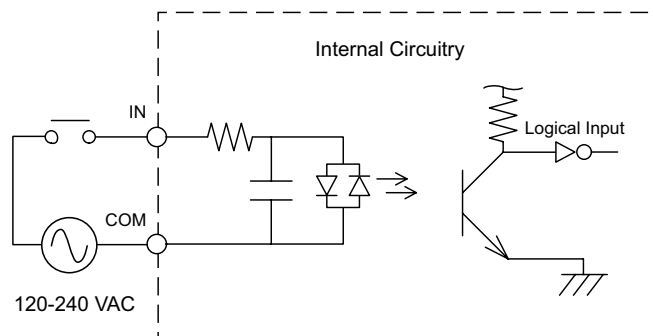

BX-DM1E-18AR3 Wiring, Continued

Discrete Output Specifications

Discrete Output Specifications	
Output Type	Relay Form A (SPST)
Total Outputs per Module	8
Commons	2 (4 points/common) Isolated
Maximum Current per Common	8A
Nominal Voltage Range	12–48 VDC 24–240 VAC
Operating Voltage Range	5–60 VDC 5–264 VAC
Maximum Voltage	60VDC 264VAC
Minimum Output Current	0.1 mA @ 24VDC 0.1 mA @ 24VAC
Maximum Output Current	2A
Maximum Inrush Current	5A for 50ms
Maximum Leakage Current	1 μ A (DC), 300 μ A (AC) due to RC snubber circuit
ON Voltage Drop	0.2 V Max
Status Indicators	Logic Side, Green
Output Details	
Output Type	Standard
Location	Y0...Y7
ON-OFF Response	<10ms
OFF-ON Response	<10ms
Maximum Switching Frequency	10Hz
Relay Cycle Life	5 million operations
Mechanical Endurance	120,000 operations
Electrical Endurance	
Fuse Type	User-supplied external fuse

BX-DM1E-18AR3 Wiring, Continued

Discrete Output Connection Options

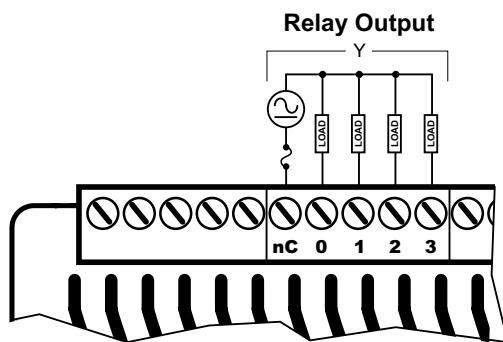

Discrete Standard Output Internal Circuitry

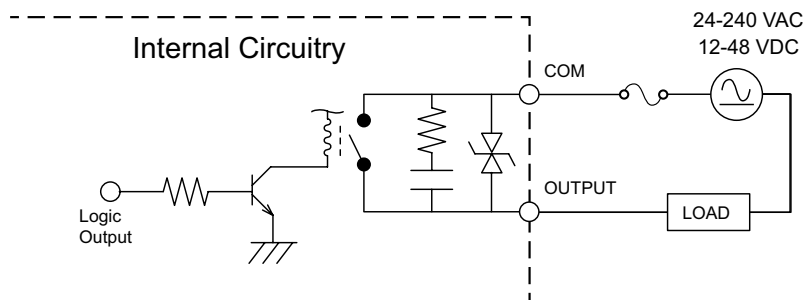

BX-DM1E-18AR3 Wiring, Continued

Analog Input Specifications

Analog Input Specifications	
Inputs per Module	1
Commons	1
Input Voltage Range *	Software Selectable $\pm 10V$, $\pm 5V$, $0-10 V$, $0-5 V$
Input Current Range *	Software Selectable $\pm 20mA$, $4-20 mA$
Resolution $\pm 10V$, $\pm 20mA$ $\pm 5V$ $0-5 V$ $4-20 mA$ $0-10 V$	16 bits (0-65535 counts) 15 bits (0-32767 counts) 14 bits (0-16383 counts) ~15 bits (6553-32767 counts) 15 bits (0-32767 counts)
Input Impedance Voltage Modes	100k Ω
Absolute Maximum Input, Voltage Mode	$\pm 30V$
Input Impedance Current Modes	249 Ω
Absolute Maximum Input, Current Mode	$\pm 40mA$ sustained, $\pm 100mA$ for < 5s
Conversion Time	1.2 ms
Input Stability	0.02% of Full Hardware Range = 13 Counts
Full Scale Calibration Error	0.05% of Full Hardware Range = 33 Counts
Offset Calibration Error	0.01% of Full Hardware Range = 7 Counts
Accuracy vs Temperature Error	0.05% of Full Hardware Range = 33 Counts
Maximum Linearity Error (End to End)	0.1% of Full Hardware Range = 66 Counts
Maximum Inaccuracy	0.2% of Full Hardware Range = 131 Counts
Fuse Type	User-supplied external fuse

* Software selectable per channel

BX-DM1E-18AR3 Wiring, Continued

Analog Input Connection Options

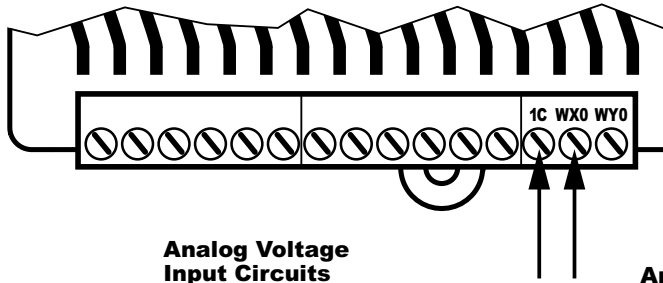

Analog Voltage Input Circuits

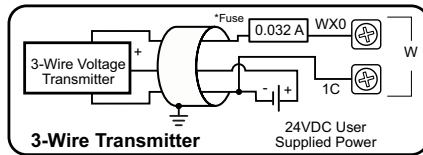
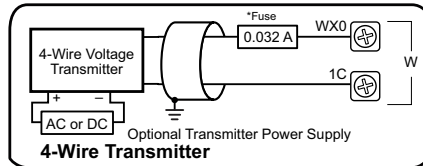

NOTE: Shield should be connected only at one end, to ground at the source device.

Analog Current Sinking Input Circuits

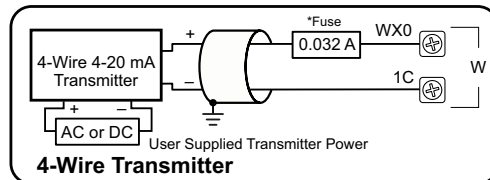
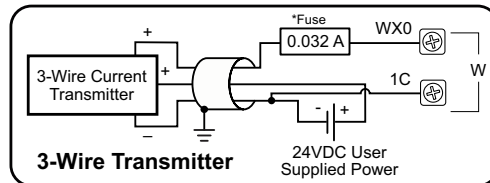
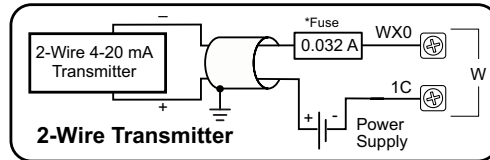

NOTE: Shield should be connected only at one end, to ground at the source device.



NOTE: An Edison S500-32-R 0.032A fast-acting fuse is recommended for all analog voltage inputs, analog outputs, and current loops.

BX-DM1E-18AR3 Wiring, Continued

Analog Output Specifications

Analog Output Specifications	
Outputs per Module	1
Commons	1
Output Voltage Range *	Software Selectable $\pm 10V$, $\pm 5V$, 0–10 V, 0–5 V
Output Current Range *	Software Selectable $\pm 20mA$, 4–20 mA
Resolution $\pm 10V$, $\pm 20mA$ $\pm 5V$ 0–5 V 4–20 mA 0–10 V	16 bits (0–65535 counts) 15 bits (0–32767 counts) 14 bits (0–16383 counts) ~15 bits (6553–32767 counts) 15 bits (0–32767 counts)
Minimum Voltage Load Impedance	1k Ω
Maximum Current Load Impedance	500 Ω
Maximum Rating	Continuous Short Circuit Protected
Settling Time	< 1ms
Output Stability	0.02% of Full Hardware Range = 13 Counts
Full Scale Calibration Error	0.05% of Full Hardware Range = 33 Counts
Offset Calibration Error	0.01% of Full Hardware Range = 7 Counts
Accuracy vs Temperature Error	0.05% of Full Hardware Range = 33 Counts
Maximum Linearity Error (End to End)	0.1% of Full Hardware Range = 66 Counts
Maximum Inaccuracy	0.2% of Full Hardware Range = 131 Counts
Fuse Type	User-supplied external fuse

* Software selectable per channel

Analog Output Connection Options

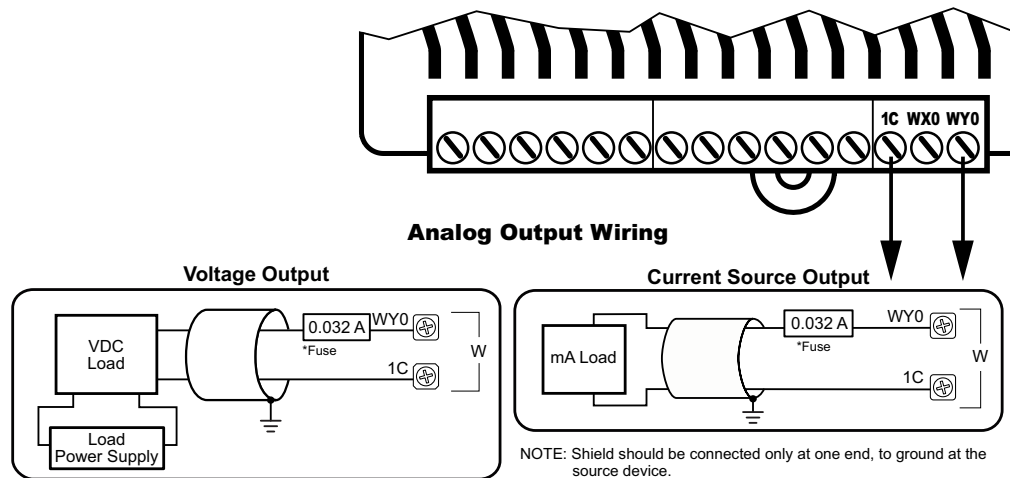

NOTE: An Edison S500-32-R 0.032A fast-acting fuse is recommended for all analog voltage inputs, analog outputs, and current loops.

Notes: